



FCC RADIO TEST REPORT

Applicant : Xema Inc.
Address : 12960 Sunnyside, Santa Fe Springs, CA 90670
Equipment : UHF RFID 4-Port Module
Model No. : M87P4
Trade Name : XEMA
FCC ID. : 2BEYTM87P4

I HEREBY CERTIFY THAT :

The sample was received on Jul. 12, 2024 and the testing was completed on Aug. 07, 2024 at CerpPASS Technology Corp. The test result refers exclusively to the test presented test model / sample. Without written approval of CerpPASS Technology Corp., the test report shall not be reproduced except in full.

Approved by:

Mark Liao / Supervisor

Laboratory Accreditation:

CerpPASS Technology Corporation Test Laboratory





CONTENTS

1. Summary of Test Procedure and Test Results	5
1.1 Applicable Standards	5
2. Test Configuration of Equipment under Test	6
2.1 Feature of Equipment under Test	6
2.2 Carrier Frequency of Channes	6
2.3 Test Mode & Test Software	7
2.4 Description of Test System	8
2.5 General Information of Test	9
2.6 Measurement Uncertainty	10
3. Test Equipment and Ancillaries Used for Tests	11
4. Antenna Requirements	13
4.1 Standard Applicable	13
4.2 Antenna Construction and Directional Gain	13
5. Test of AC Power Line Conducted Emission	14
5.1 Test Limit	14
5.2 Test Procedures	14
5.3 Typical Test Setup	15
5.4 Test Result and Data	16
5.5 Test Photographs	22
6. Test of Radiated Spurious Emission	23
6.1 Test Limit	23
6.2 Test Procedures	23
6.3 Typical Test Setup	24
6.4 Test Result and Data (9kHz ~ 30MHz)	25
6.5 Test Result and Data (30MHz ~ 1GHz)	25
6.6 Test Result and Data (1GHz ~ 25GHz)	31
6.7 Restricted Bands of Operation	37
6.8 Test Photographs (30MHz ~ 1GHz)	38
6.9 Test Photographs (1GHz ~ 25GHz)	39
7. Test of Conducted Spurious Emission	40
7.1 Test Limit	40
7.2 Test Procedure	40
7.3 Test Setup Layout	40
7.4 Test Result and Data	40
8. On Time, Duty Cycle and Measurement methods	43
8.1 Test Limit	43
8.2 Test Procedure	43
8.3 Test Setup Layout	43
8.4 Test Result and Data	43
9. 20dB Bandwidth Measurement Data	44
9.1 Test Limit	44
9.2 Test Procedures	44



- 9.3 Test Setup Layout 44
- 9.4 Test Result and Data 44
- 10. Frequencies Separation 46**
 - 10.1 Test Limit 46
 - 10.2 Test Procedures 46
 - 10.3 Test Setup Layout 46
 - 10.4 Test Result and Data 46
- 11. Dwell Time on each channel 48**
 - 11.1 Test Limit 48
 - 11.2 Test Procedures 48
 - 11.3 Test Setup Layout 48
 - 11.4 Test Result and Data 48
- 12. Number of Hopping Channels 50**
 - 12.1 Test Limit 50
 - 12.2 Test Procedures 50
 - 12.3 Test Setup Layout 50
 - 12.4 Test Result and Data 50
- 13. Maximum Peak Output Power 52**
 - 13.1 Test Limit 52
 - 13.2 Test Procedures 52
 - 13.3 Test Setup Layout 52
 - 13.4 Test Result and Data 53
- 14. Radio Frequency Exposure 54**
 - 14.1 Applicable Standards 54
 - 14.2 EUT Specification 55
 - 14.3 Result 55



History of this test report

Report No.	Issued Date	Description
24090112-TRFCC01	Sep. 30, 2024	Original

Report Type		Description
<input type="checkbox"/>	Original report	NA
<input checked="" type="checkbox"/>	Derivative Report	This sample provided has been confirmed to be identical to the original report sample. The only difference are as listed below. As it doesn't affect the test result, the original report number: 24070239-TRFCC01 and content will be used. <ol style="list-style-type: none">1. Applicant information change.2. Equipment Name change.3. Model No. change.4. Trade Name change.5. FCC ID. . change.



1. Summary of Test Procedure and Test Results

1.1 Applicable Standards

ANSI C63.10:2013

FCC Rules and Regulations Part 15 Subpart C §15.247

FCC Rule	Description of Test	Result
15.203	. Antenna Requirement	PASS
15.207	. AC Power Line Conducted Emission	PASS
15.209 15.205	. Radiated Spurious Emission	PASS
15.247(d)	. Conducted Spurious Emission	PASS
15.247(a)(1)	. Channel Carrier Frequencies Separation	PASS
15.247(a)(1)	. 20dB Bandwidth	PASS
15.247(a)(1)	. Dwell Time	PASS
15.247(b)	. Number of Hopping Channels	PASS
15.247(b)	. Peak Output Power Measurement Data	PASS

*The lab has reduced the uncertainty risk factor from test equipment, environment and staff technicians which according to the standard on contract. Therefore, the test result will only be determined by standard requirement, measurement uncertainty evaluation is not considered.



2. Test Configuration of Equipment under Test

2.1 Feature of Equipment under Test

Operation Frequency Range	902MHz~928MHz
Modulation Type	ASK
Antenna Type	Patch Antenna
Antenna Gain	ANT 1/2/3/4: 5.5dBi
Antenna Cable Loss	0.5dBi

Note:

1. Antenna & Antenna Cable are not sold with the EUT.
2. For more details, please refer to the User's manual of the EUT.

2.2 Carrier Frequency of Channes

Channel No.	Frequency(MHz)	Channel No.	Frequency(MHz)
*1	902.75	26	915.25
2	903.25	27	915.75
3	903.75	28	916.25
4	904.25	29	916.75
5	904.75	30	917.25
6	905.25	31	917.75
7	905.75	32	918.25
8	906.25	33	918.75
9	906.75	34	919.25
10	907.25	35	919.75
11	907.75	36	920.25
12	908.25	37	920.75
13	908.75	38	921.25
14	909.25	39	921.75
15	909.75	40	922.25
16	910.25	41	922.75
17	910.75	42	923.25
18	911.25	43	923.75
19	911.75	44	924.25
20	912.25	45	924.75
21	912.75	46	925.25
22	913.25	47	925.75
23	913.75	48	926.25
24	914.25	49	926.75
*25	914.75	*50	927.25

Note: Channels remarked * are selected to perform test.



2.3 Test Mode & Test Software

- a. During testing, the interface cables and equipment positions were varied according to ANSI C63.10
- b. The complete test system included Notebook and EUT for RF test.
- c. An executive program, " Docklight Scripting v2.0.5" under Windows OS system was executed to transmit and receive data via RFID.
- d. The following test modes were performed for the test:

Conducted Emissions from the AC mains power ports	
Test Mode	Operating Description
1	TX Mode, DC 5.2V/2A Power from DC Power Supply(AC 120V/60Hz)
caused "Test Mode 1" generated the worst case, it was reported as the final data.	
Radiation Emissions (30MHz ~ 1GHz)	
Test Mode	Operating Description
1	TX Mode, DC 5.2V/2A Power from DC Power Supply(AC 120V/60Hz)
caused "Test Mode 1" generated the worst case, they were reported as the final data.	
Radiation Emissions (1GHz ~ 25GHz)	
Test Mode	Operating Description
1	TX Mode, DC 5.2V/2A Power from DC Power Supply(AC 120V/60Hz)
caused "Test Mode 1" generated the worst case, they were reported as the final data.	

Note: There are four ports of EUT, Port1/2/3/4. After engineering evaluation, Port 2 is worst case, hence, is used at test report.

Modulation Type	TX CONFIGURATION
ASK	1TX



2.4 Description of Test System

RF Conducted				
Equipment	Brand	Model	Length/Type	Power cord/Length/Type
Antenna Cable*4	N/A	N/A	1.2m / NS	N/A
Notebook	lenovo	S1GL2W	N/A	N/A
USB Cable	N/A	N/A	1.8m / NS	N/A
Testfixture	N/A	N/A	N/A	N/A
DC Power Supply	Gwinstek	GPR-360600	N/A	N/A
Radiated Emissions				
Equipment	Brand	Model	Length/Type	Power cord/Length/Type
Antenna*4	N/A	N/A	0.1m / NS	N/A
Antenna Cable*4	N/A	N/A	1.2m / NS	N/A
Notebook	DELL	Latitude E5470	N/A	Adapter / 1.8m / NS
USB Cable	N/A	N/A	1.8m / NS	N/A
Testfixture	N/A	N/A	N/A	N/A
DC Power Supply	Gwinstek	GPR-360600	N/A	N/A
AC Power Line Conducted Emission				
Equipment	Brand	Model	Length/Type	Power cord/Length/Type
Antenna*4	N/A	N/A	0.1m / NS	N/A
Antenna Cable*4	N/A	N/A	1.2m / NS	N/A
Notebook	DELL	Latitude E5470	N/A	Adapter / 1.8m / NS
USB Cable	N/A	N/A	1.8m / NS	N/A
Testfixture	N/A	N/A	N/A	N/A
DC Power Supply	Gwinstek	GPR-360600	N/A	N/A



2.5 General Information of Test

☒ Test Site	CerpPASS Technology Corporation Test Laboratory Address: No.10, Ln. 2, Lianfu St., Luzhu Dist., Taoyuan City 33848, Taiwan (R.O.C.) Tel: +886-3-3226-888 Fax: +886-3-3226-881	
	FCC	TW1439, TW1079
	IC	4934E-1, 4934E-2
Frequency Range Investigated	Conducted: from 150kHz to 30 MHz Radiation: from 9 KHz to 10,000MHz	
Test Distance	The test distance of radiated emission from antenna to EUT is 3 M.	

Test Item	Test Site	Test Period	Environmental Conditions	Tested By
RF Conducted	RFCON01-NK	2024/07/22	24.7°C / 53%	Leon Huang
RF Conducted	RFCON01-NK	2024/08/07	25.8°C / 39%	Leon Huang
Radiated Emissions	3M02-NK	2024/08/06	24.9°C / 45%	Leon Haung
AC Power Line Conducted Emission	CON02-NK	2024/07/26	26.1°C / 54%	Park Chen



2.6 Measurement Uncertainty

ISO/IEC 17025 requires that an estimate of the measurement uncertainties associated with the emissions test results be included in the report. The measurement uncertainties given below are based on a 95% confidence level (based on a coverage factor (k=2))

Measurement Item	Uncertainty
AC Power Line Conducted Emission	±3.12dB
Radiated Spurious Emission(9KHz~30MHz)	±3.405dB
Radiated Spurious Emission(30MHz~1GHz)	±5.326dB
Radiated Spurious Emission(1GHz~25GHz)	±5.918dB
Conducted Spurious Emission	±2.156dB
20dB Bandwidth	±4.40%
Peak Output Power(Conducted Power Meter)	±1.31dB
Dwell Time	±0.11%
Duty Cycle	±0.17%



3. Test Equipment and Ancillaries Used for Tests

Test Item	Radiated Emissions				
Test Site	Semi Anechoic Room(3M02-NK)				
Instrument	Manufacturer	Model No	Serial No	Calibration Date	Valid Date
Bilog Antenna	Schwarzbeck	VULB9168	369	2024/02/19	2025/02/18
Active Loop Antenna	Schwarzbeck	FMZB 1513	414	2024/01/16	2025/01/15
Horn Antenna	EMCO	3115	31589	2024/02/26	2025/02/25
Horn Antenna	EMCO	3116	31974	2023/10/16	2024/10/15
EMI Receiver	ROHDE & SCHWARZ	ESR 7	101906	2024/05/13	2025/05/12
Spectrum Analyzer	ROHDE & SCHWARZ	FSV 40-N	102151	2023/08/15	2024/08/14
Preamplifier	Agilent	8449B	3008A01954	2024/03/01	2025/02/28
Preamplifier	EMC INSTRUMENTS	EMC184045	980065	2023/10/13	2024/10/12
Preamplifier	EM Electronics corp.	EM330	60659	2024/02/17	2025/02/16
Cable-6m(9k~300M)	N/A	EMC5D-BM-BM-6	130606	2024/03/13	2025/03/12
Cable-3in1(30M-1G)	HARBOUR INDUSTRIES	LL142	CCE1315	2024/02/23	2025/02/22
Cable-0.5m(1G-40G)	HUBER SUHNER	SUCOFLEX 104	805443/4	2024/03/05	2025/03/04
Cable-3m(1G-40G)	HUBER SUHNER	SUCOFLEX 104	805796/4	2024/03/05	2025/03/04
Cable-8m(1G-26.5G)	WOKEN	WCBA-WCA203SM	CCE1374	2024/03/05	2025/03/04
Cable-1m(1G-40G)	HUBER SUHNER	HUBER SUHNER / SF102	804398/2	2023/10/12	2024/10/11
Cable-3m(1G-40G)	HUBER SUHNER	HUBER SUHNER / SF102	804619/2	2023/10/12	2024/10/11
E3	AUDIX	v8.2014-8-6	RK-000529	NA	NA
Highpass Filter	WOKEN	WFIL-H3000-18000F-03	WR377WC2B1	2023/08/17	2024/08/16
Notch Filter	Warison	WFIL-N5925-7125F-04	WRQ4BFWC4M1	2024/03/11	2025/03/10
Hipass Filter	Warison	WFIL-H7500-18000F	WRQ4BFWC2J1	2024/03/11	2025/03/10

Test Item	RF Conducted				
Test Site	RFCON01-NK				
Instrument	Manufacturer	Model No	Serial No	Calibration Date	Valid Date
Spectrum Analyzer	ROHDE & SCHWARZ	FSP 40	100047	2024/02/01	2025/01/31
Attenuator	KEYSIGHT	8491B	MY39250703	2024/02/20	2025/02/19
Cable-0.5m(30M-40G)	HUBER SUHNER	SUCOFLEX 102	28420/2	2023/10/12	2024/10/11
Power Meter	Anritsu	ML2495A	1224005	2024/02/17	2025/02/16
Power Sensor	Anritsu	MA2411B	1207295	2024/02/17	2025/02/16
Switch Box	Theda	1-4	TW5451159	NA	NA



Test Item	AC Power Line Conducted Emission				
Test Site	CON02-NK				
Instrument	Manufacturer	Model No	Serial No	Calibration Date	Valid Date
EMI Receiver	ROHDE & SCHWARZ	ESR 7	101906	2024/05/13	2025/05/12
TWO-LINE V-NETWORK	ROHDE & SCHWARZ	ENV216	102185	2023/08/29	2024/08/28
Cable-6m(9k~300M)	N/A	EMC5D-BM-BM-6	130606	2024/03/13	2025/03/12
E3	AUDIX	v8.2014-8-6	RK-000536	NA	NA



4. Antenna Requirements

4.1 Standard Applicable

For intentional device, according to FCC 47 CFR Section 15.203, an intentional radiator shall be designed to ensure that no antenna other than that furnished by the responsible party shall be used with the device.

And according to FCC 47 CFR Section 15.247 (b), if transmitting antennas of directional gain greater than 6dBi are used, the power shall be reduced by the amount in dB that the directional gain of the antenna exceeds 6dBi.

4.2 Antenna Construction and Directional Gain

Antenna Type	Patch Antenna
Antenna Gain	5.5dBi



5. Test of AC Power Line Conducted Emission

5.1 Test Limit

Conducted Emissions were measured from 150 kHz to 30 MHz with a bandwidth of 9 KHz, according to the methods defined in ANSI C63.10-2013. The EUT was placed on a nonmetallic stand in a shielded room 0.8 meters above the ground plane. The interface cables and equipment positioning were varied within limits of reasonable applications to determine the position produced maximum conducted emissions.

Frequency (MHz)	Quasi Peak (dB μ V)	Average (dB μ V)
0.15 – 0.5	66-56*	56-46*
0.5 – 5.0	56	46
5.0 – 30.0	60	50

*Decreases with the logarithm of the frequency.

5.2 Test Procedures

- a. The EUT was placed 0.4 meter from the conducting wall of the shielding room was kept at least 80 centimeters from any other grounded conducting surface.
- b. Connect EUT to the power mains through a line impedance stabilization network (LISN).
- c. All the support units are connecting to the other LISN.
- d. The LISN provides 50 ohm coupling impedance for the measuring instrument.
- e. The FCC states that a 50 ohm, 50 micro-Henry LISN should be used.
- f. Both sides of AC line were checked for maximum conducted interference.
- g. The frequency range from 150 kHz to 30 MHz was searched.
- h. Set the test-receiver system to Peak Detect Function and Specified Bandwidth with Maximum Hold Mode.



5.3 Typical Test Setup

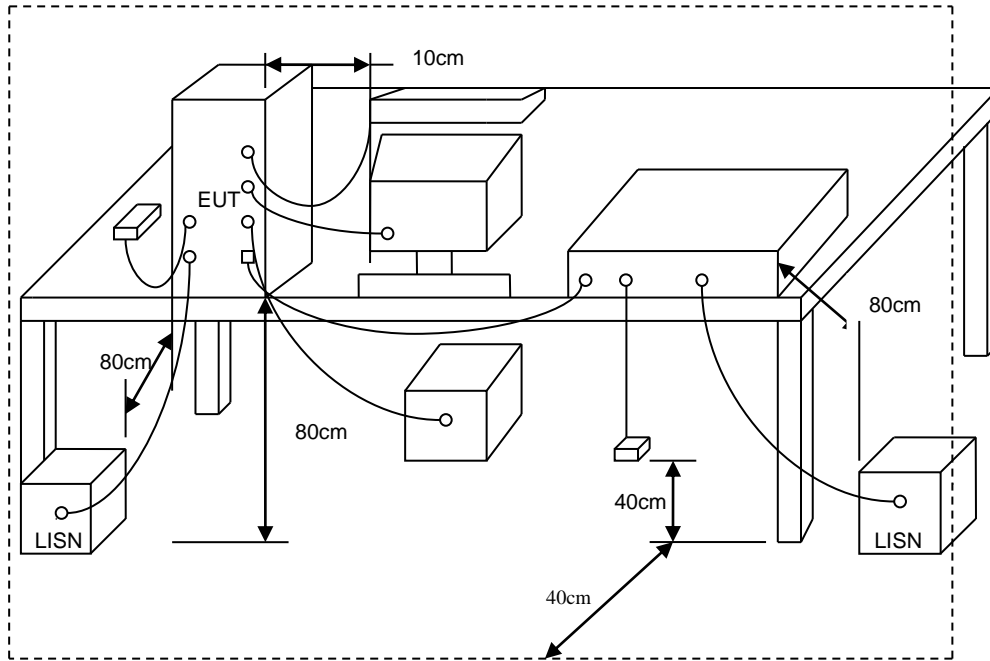



5.4 Test Result and Data

Test Mode : RFID 1TX 902.75MHz
Voltage : From DC Power Supply(5.2V/2A)
Phase : Line

Data: 3

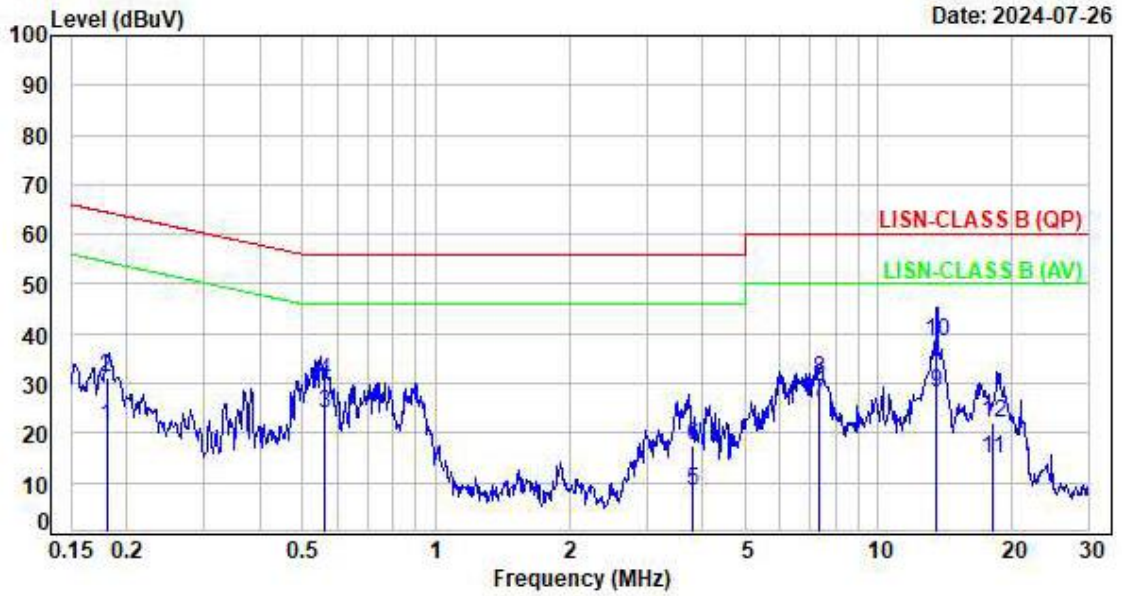

No.	Frequency (MHz)	Factor (dB)	Reading (dBuV)	Level (dBuV)	Limit (dBuV)	Margin (dB)	Detector	P/F
1	0.1803	9.64	11.56	21.20	54.47	-33.27	Average	P
2	0.1803	9.64	21.62	31.26	64.47	-33.21	QP	P
3	0.5622	9.64	14.26	23.90	46.00	-22.10	Average	P
4	0.5622	9.64	20.61	30.25	56.00	-25.75	QP	P
5	3.7889	9.75	-1.50	8.25	46.00	-37.75	Average	P
6	3.7889	9.75	7.74	17.49	56.00	-38.51	QP	P
7	7.3300	9.84	16.31	26.15	50.00	-23.85	Average	P
8	7.3300	9.84	21.05	30.89	60.00	-29.11	QP	P
9	13.5600	9.92	18.30	28.22	50.00	-21.78	Average	P
10	13.5600	9.92	28.65	38.57	60.00	-21.43	QP	P
11	18.1606	9.96	4.98	14.94	50.00	-35.06	Average	P
12	18.1606	9.96	12.22	22.18	60.00	-37.82	QP	P

Note: Level=Reading+Factor
Margin=Level-Limit
Factor=(LISN or ISN or Current Probe)Factor + Cable Loss



Test Mode : RFID 1TX 902.75MHz
Voltage : From DC Power Supply(5.2V/2A)
Phase : Neutral

Data: 4

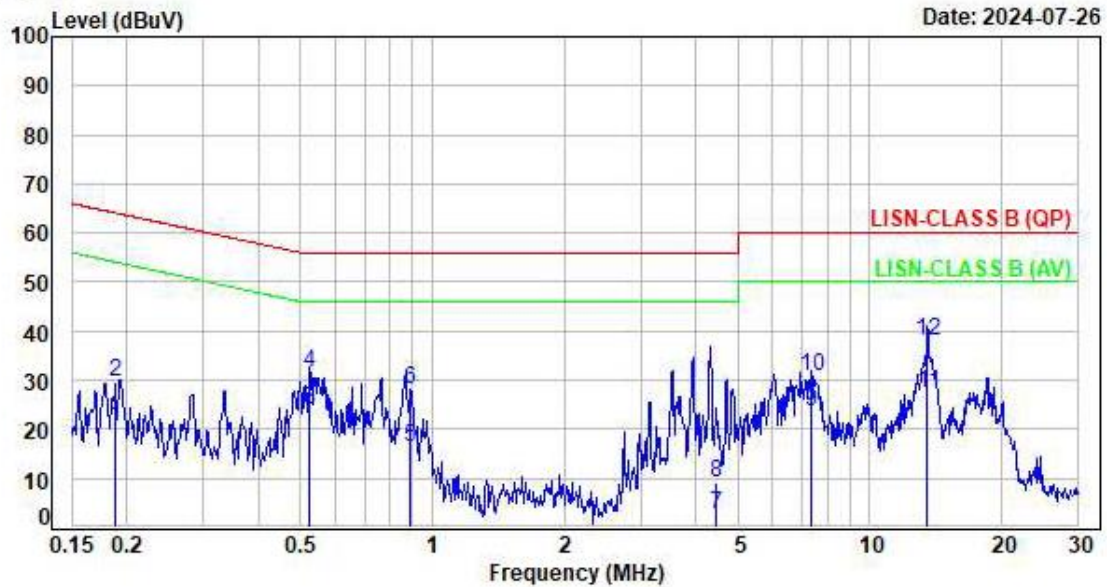

Table with 9 columns: No., Frequency (MHz), Factor (dB), Reading (dBUV), Level (dBUV), Limit (dBUV), Margin (dB), Detector, P/F. It contains 12 rows of test data points.

Note: Level=Reading+Factor
Margin=Level-Limit
Factor=(LISN or ISN or Current Probe)Factor + Cable Loss



Test Mode : RFID 1TX 914.75MHz
Voltage : From DC Power Supply(5.2V/2A)
Phase : Line

Data: 5

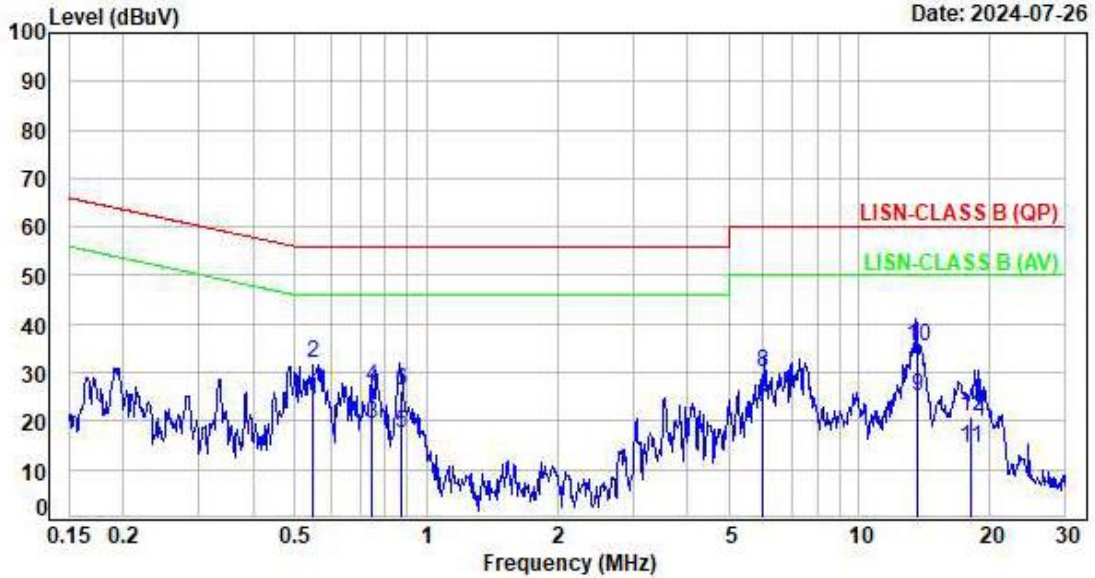

No.	Frequency (MHz)	Factor (dB)	Reading (dBuV)	Level (dBuV)	Limit (dBuV)	Margin (dB)	Detector	P/F
1	0.5496	9.64	14.69	24.33	46.00	-21.67	Average	P
2	0.5496	9.64	22.13	31.77	56.00	-24.23	QP	P
3	0.7427	9.64	9.91	19.55	46.00	-26.45	Average	P
4	0.7427	9.64	17.39	27.03	56.00	-28.97	QP	P
5	0.8714	9.64	7.99	17.63	46.00	-28.37	Average	P
6	0.8714	9.64	16.75	26.39	56.00	-29.61	QP	P
7	6.0059	9.82	12.91	22.73	50.00	-27.27	Average	P
8	6.0059	9.82	20.30	30.12	60.00	-29.88	QP	P
9	13.5979	9.92	15.19	25.11	50.00	-24.89	Average	P
10	13.5979	9.92	25.47	35.39	60.00	-24.61	QP	P
11	18.1484	9.96	4.36	14.32	50.00	-35.68	Average	P
12	18.1484	9.96	10.87	20.83	60.00	-39.17	QP	P

Note: Level=Reading+Factor
Margin=Level-Limit
Factor=(LISN or ISN or Current Probe)Factor + Cable Loss



Test Mode : RFID 1TX 914.75MHz
Voltage : From DC Power Supply(5.2V/2A)
Phase : Neutral

Data: 6

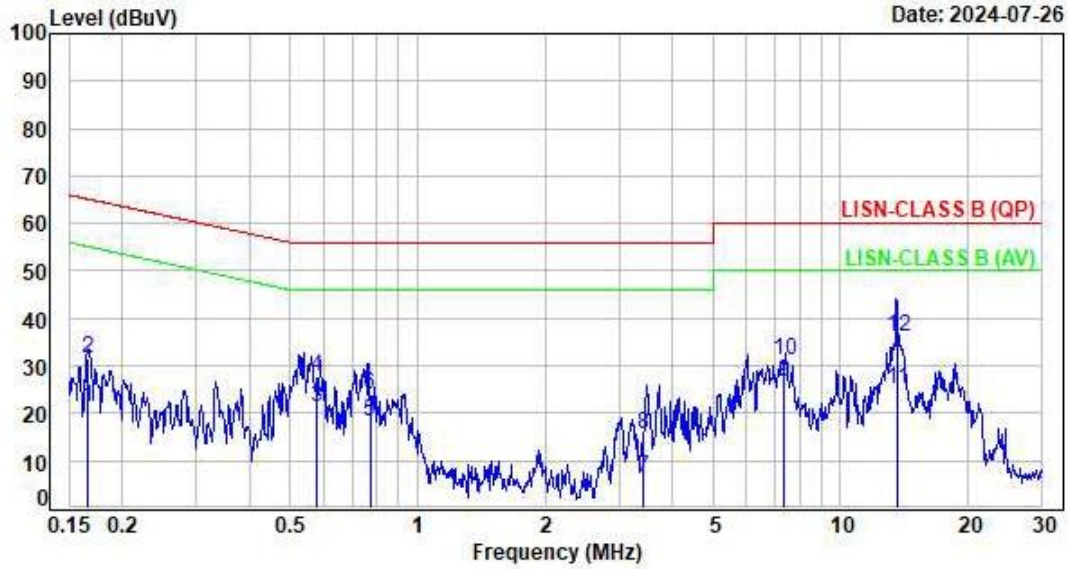

Table with 9 columns: No., Frequency (MHz), Factor (dB), Reading (dBuV), Level (dBuV), Limit (dBuV), Margin (dB), Detector, P/F. It contains 12 rows of test data points.

Note: Level=Reading+Factor
Margin=Level-Limit
Factor=(LISN or ISN or Current Probe)Factor + Cable Loss



Test Mode : RFID 1TX 927.25MHz
Voltage : From DC Power Supply(5.2V/2A)
Phase : Line

Data: 7

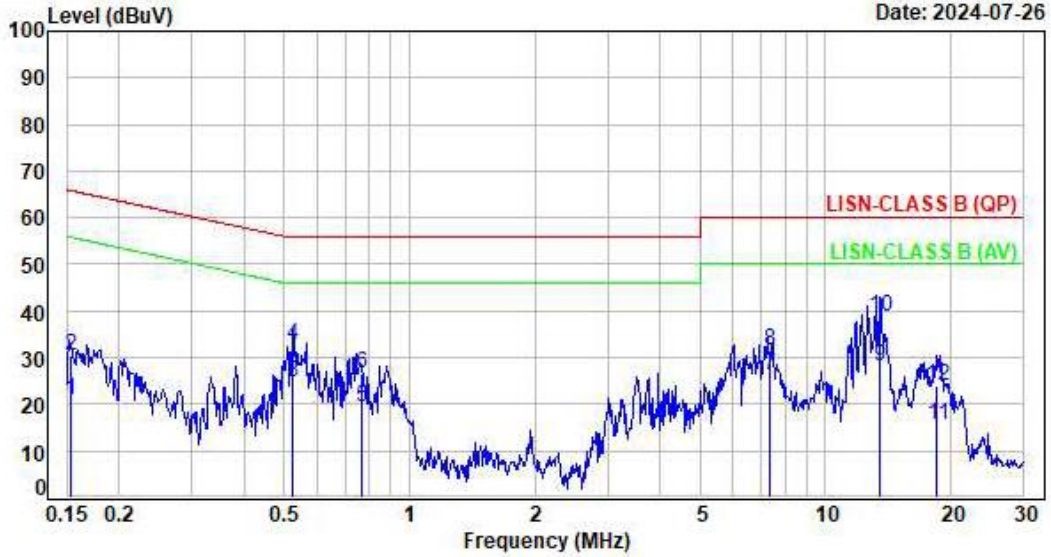

No.	Frequency (MHz)	Factor (dB)	Reading (dBuV)	Level (dBuV)	Limit (dBuV)	Margin (dB)	Detector	P/F
1	0.1528	9.65	11.25	20.90	55.85	-34.95	Average	P
2	0.1528	9.65	20.64	30.29	65.85	-35.56	QP	P
3	0.5240	9.64	15.00	24.64	46.00	-21.36	Average	P
4	0.5240	9.64	23.23	32.87	56.00	-23.13	QP	P
5	0.7643	9.64	9.89	19.53	46.00	-26.47	Average	P
6	0.7643	9.64	17.05	26.69	56.00	-29.31	QP	P
7	7.3300	9.84	16.32	26.16	50.00	-23.84	Average	P
8	7.3300	9.84	21.64	31.48	60.00	-28.52	QP	P
9	13.5525	9.92	18.29	28.21	50.00	-21.79	Average	P
10	13.5525	9.92	29.03	38.95	60.00	-21.05	QP	P
11	18.5622	9.96	5.68	15.64	50.00	-34.36	Average	P
12	18.5622	9.96	13.90	23.86	60.00	-36.14	QP	P

Note: Level=Reading+Factor
Margin=Level-Limit
Factor=(LISN or ISN or Current Probe)Factor + Cable Loss



Test Mode : RFID 1TX 927.25MHz
Voltage : From DC Power Supply(5.2V/2A)
Phase : Neutral

Data: 8

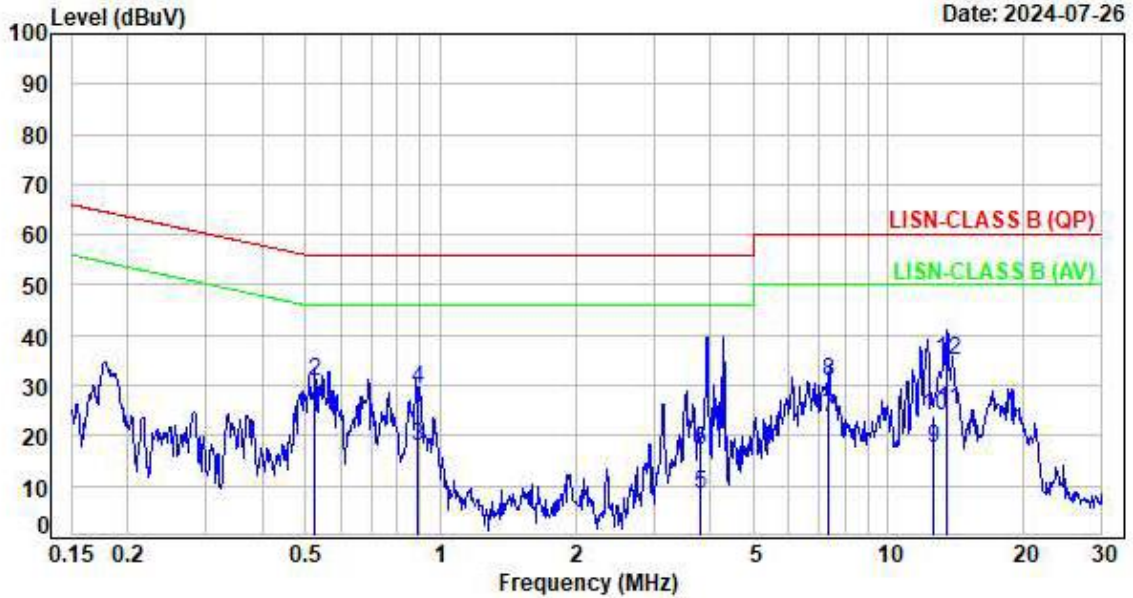

Table with 9 columns: No., Frequency (MHz), Factor (dB), Reading (dBUV), Level (dBUV), Limit (dBUV), Margin (dB), Detector, P/F. It contains 12 rows of test data points.

Note: Level=Reading+Factor
Margin=Level-Limit
Factor=(LISM or ISN or Current Probe)Factor + Cable Loss



6. Test of Radiated Spurious Emission

6.1 Test Limit

In any 100kHz bandwidth outside the frequency band in which the spread spectrum or digitally modulated intentional radiator is operating, the radio frequency power that is produced by the intentional radiator shall be at least 20dB below that in the 100kHz bandwidth within the band that contains the highest level of the desired power, based on either an RF conducted or a radiated measurement. If the transmitter measurement is based on the maximum conducted output power, the attenuation required under this paragraph shall be 30dB instead of 20dB. In addition, radiated emissions which fall in section 15.205(a) the restricted bands must also comply with the radiated emission limit specified in section 15.209(a).

Frequency (MHz)	Field Strength (microvolt/meter)	Measurement Distance (meters)
0.009 ~ 0.490	2400/F(kHz)	300
0.490 ~ 1.705	24000/F(kHz)	30
1.705 ~ 30.0	30	30
30 ~ 88	100	3
88 ~ 216	150	3
216 ~ 960	200	3
Above 960	500	3

6.2 Test Procedures

- a. The EUT was placed on a rotatable table top 0.8 meter above ground.
- b. The EUT was set 3 meters from the interference receiving antenna which was mounted on the top of a variable height antenna tower.
- c. The table was rotated 360 degrees to determine the position of the highest radiation.
- d. The antenna is a broadband antenna and its height is varied between one meter and four meters above ground to find the maximum value of the field strength both horizontal polarization and vertical polarization of the antenna are set to make the measurement.
- e. For each suspected emission the EUT was arranged to its worst case and then tune the antenna tower (from 1 M to 4 M) and turn table (from 0 degree to 360 degrees) to find the maximum reading.
- f. Set the test-receiver system to Peak or CISPR quasi-peak Detect Function and specified bandwidth with Maximum Hold Mode.
- g. If the emission level of the EUT in peak mode was 3 dB lower than the limit specified, then testing will be stopped and peak values of EUT will be reported, otherwise, the emissions which do not have 3 dB margin will be repeated one by one using the quasi-peak method and reported.
- h. For testing above 1GHz, the emission level of the EUT in peak mode was 20dB lower than average limit (that means the emission level in peak mode also complies with the limit in average mode), then testing will be stopped and peak values of EUT will be reported, otherwise, the emissions will be measured in average mode again and reported.

Note: The supporting fixture shall permit orientation of the EUT in each of three orthogonal axis positions such that emissions from the EUT are maximized.



6.3 Typical Test Setup

Below 30MHz test setup

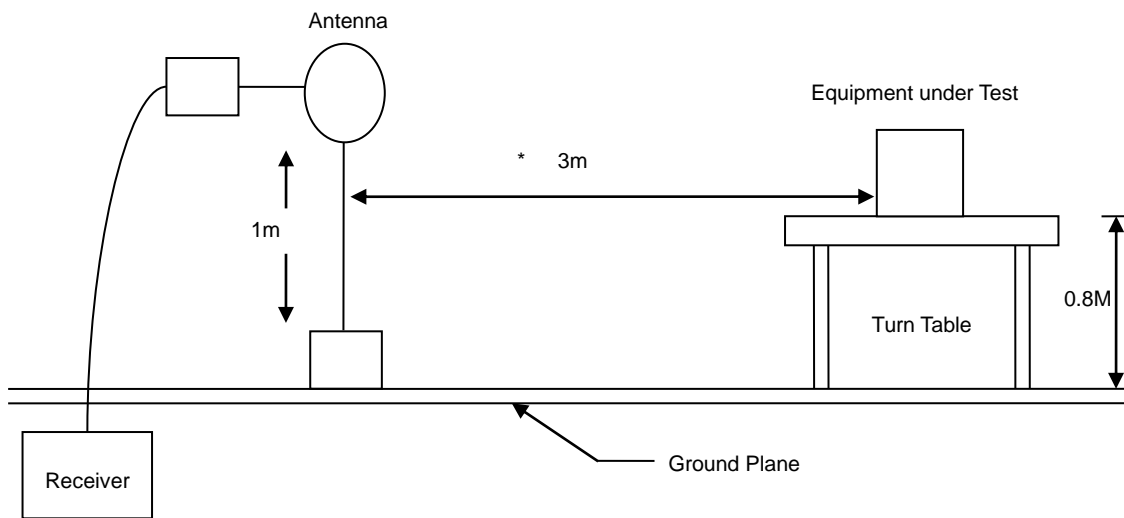

30MHz- 1GHz Test Setup

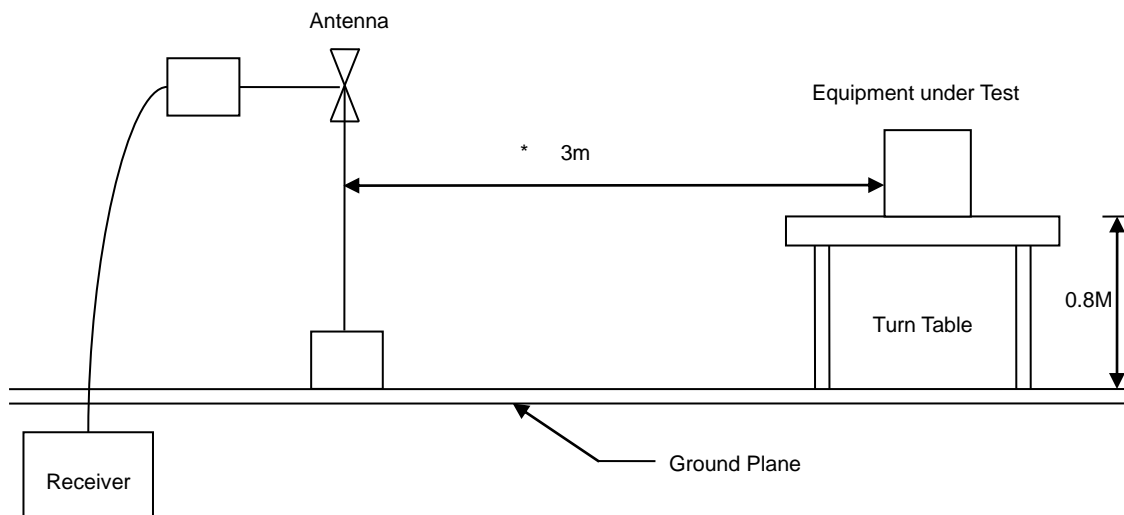

Above 1GHz Test Setup

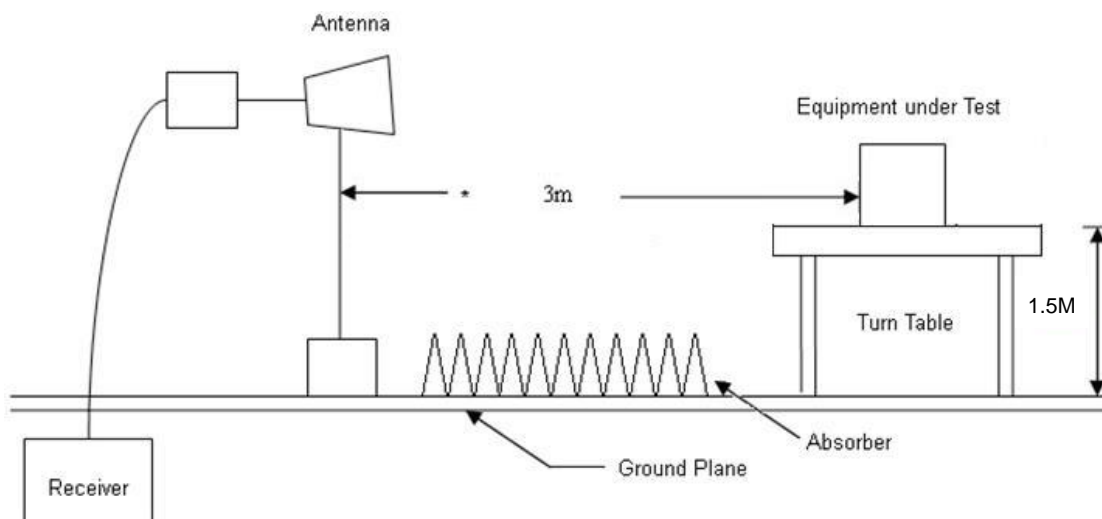



6.4 Test Result and Data (9kHz ~ 30MHz)

The 9kHz-30MHz spurious emission is under limit 20dB more.

6.5 Test Result and Data (30MHz ~ 1GHz)

Test Mode : RFID 1TX 902.75MHz
Voltage : AC110V/60Hz From PowerSupply DC(5.2v/2A)
Pol : Vertical

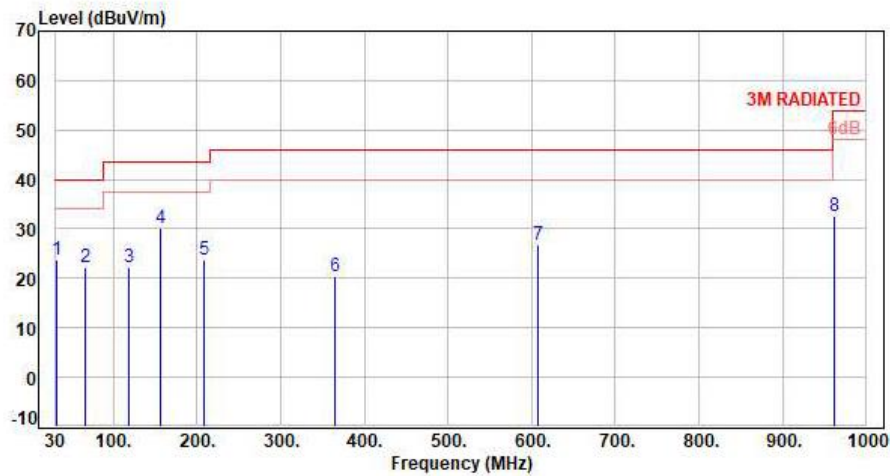

No.	Frequency (MHz)	Factor (dB)	Reading (dBuV)	Level (dBuV/m)	Limit (dBuV/m)	Margin (dB)	Detector	Height (cm)	Azimuth (deg)	P/F
1	31.94	-10.04	33.93	23.89	40.00	-16.11	Peak	400	360	P
2	66.86	-10.99	33.19	22.20	40.00	-17.80	Peak	400	360	P
3	119.24	-12.25	34.60	22.35	43.50	-21.15	Peak	400	360	P
4	156.10	-9.44	39.66	30.22	43.50	-13.28	Peak	400	360	P
5	208.48	-12.26	36.02	23.76	43.50	-19.74	Peak	400	360	P
6	365.62	-6.68	27.22	20.54	46.00	-25.46	Peak	400	360	P
7	608.12	-0.67	27.42	26.75	46.00	-19.25	Peak	400	360	P
8	961.20	4.70	27.80	32.50	54.00	-21.50	Peak	400	360	P

Note: Level=Reading+Factor
Margin=Level-Limit
Factor=Antenna Factor + cable loss - Amplifier Factor



Test Mode : RFID 1TX 902.75MHz
Voltage : AC110V/60Hz From PowerSupply DC(5.2v/2A)
Pol : Horizontal

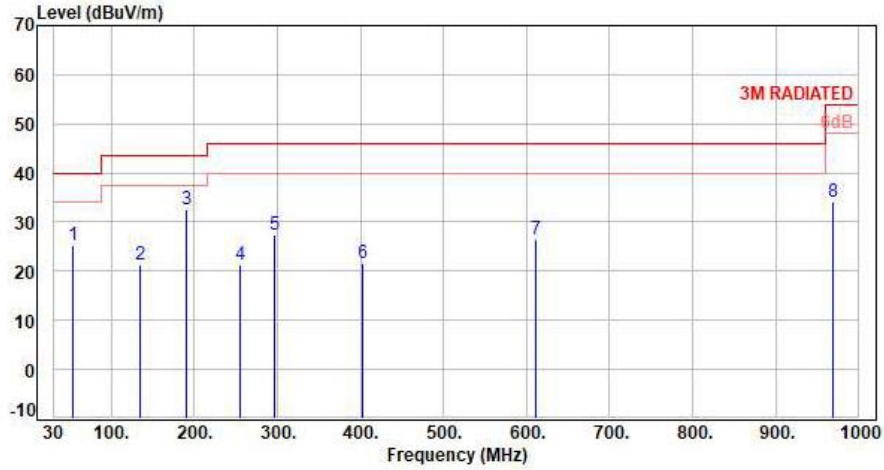

Table with 10 columns: No., Frequency (MHz), Factor (dB), Reading (dBuV), Level (dBuV/m), Limit (dBuV/m), Margin (dB), Detector, Height (cm), Azimuth (deg), P/F. Contains 8 rows of data.

Note: Level=Reading+Factor
Margin=Level-Limit
Factor=Antenna Factor + cable loss - Amplifier Factor



Test Mode : RFID 1TX 914.75MHz
Voltage : AC110V/60Hz From PowerSupply DC(5.2v/2A)
Pol : Horizontal

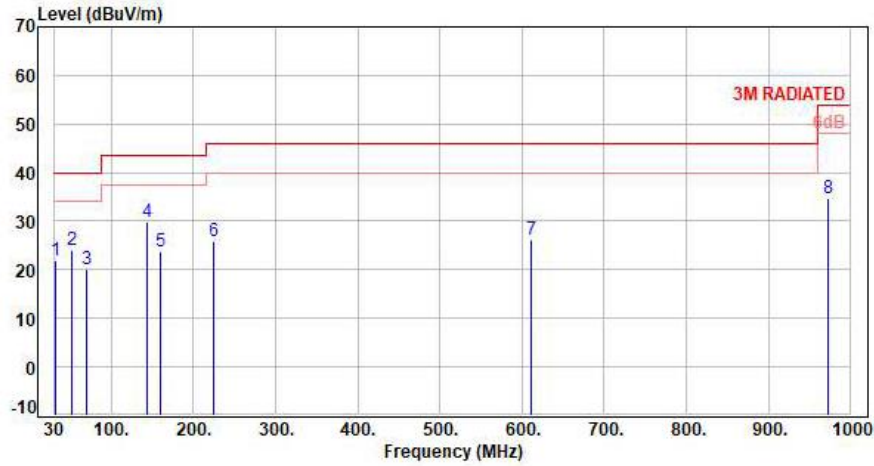
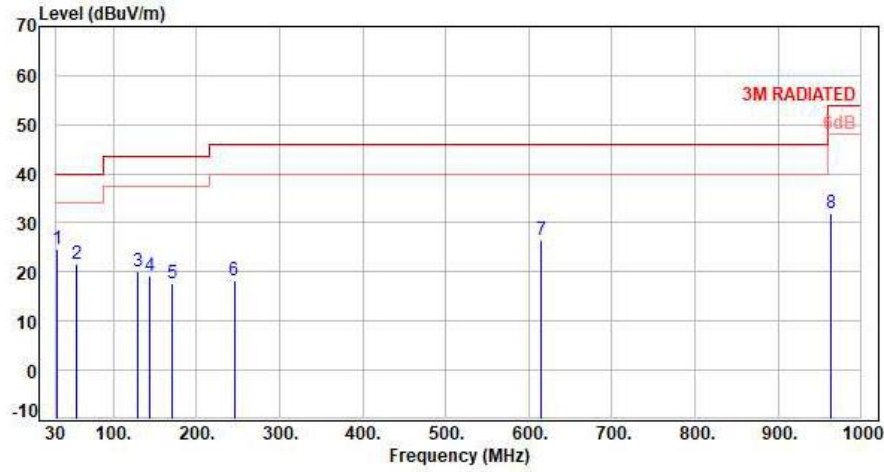

Table with 11 columns: No., Frequency (MHz), Factor (dB), Reading (dBuV), Level (dBuV/m), Limit (dBuV/m), Margin (dB), Detector, Height (cm), Azimuth (deg), P/F. It lists 8 data points corresponding to the peaks in the graph.

Note: Level=Reading+Factor
Margin=Level-Limit
Factor=Antenna Factor + cable loss - Amplifier Factor



Test Mode : RFID 1TX 914.75MHz
Voltage : AC110V/60Hz From PowerSupply DC(5.2v/2A)
Pol : Vertical



No.	Frequency (MHz)	Factor (dB)	Reading (dBuV)	Level (dBuV/m)	Limit (dBuV/m)	Margin (dB)	Detector	Height (cm)	Azimuth (deg)	P/F
1	31.94	-10.04	34.66	24.62	40.00	-15.38	Peak	400	360	P
2	55.22	-9.22	30.74	21.52	40.00	-18.48	Peak	400	360	P
3	128.94	-11.37	31.47	20.10	43.50	-23.40	Peak	400	360	P
4	144.46	-9.73	28.94	19.21	43.50	-24.29	Peak	400	360	P
5	170.65	-9.74	27.50	17.76	43.50	-25.74	Peak	400	360	P
6	245.34	-10.28	28.72	18.44	46.00	-27.56	Peak	400	360	P
7	614.00	-0.60	27.09	26.49	46.00	-19.51	Peak	400	360	P
8	963.14	4.65	27.37	32.02	54.00	-21.98	Peak	400	360	P

Note: Level=Reading+Factor
Margin=Level-Limit
Factor=Antenna Factor + cable loss - Amplifier Factor



Test Mode : RFID 1TX 927.25MHz
Voltage : AC110V/60Hz From PowerSupply DC(5.2v/2A)
Pol : Vertical

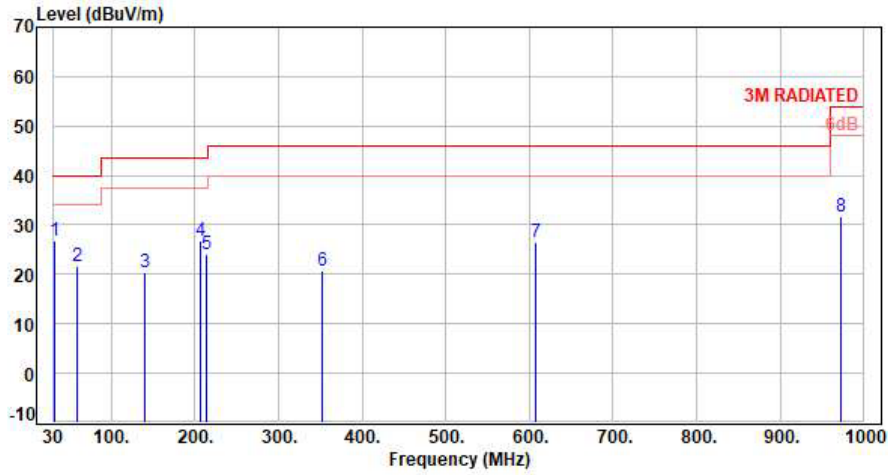
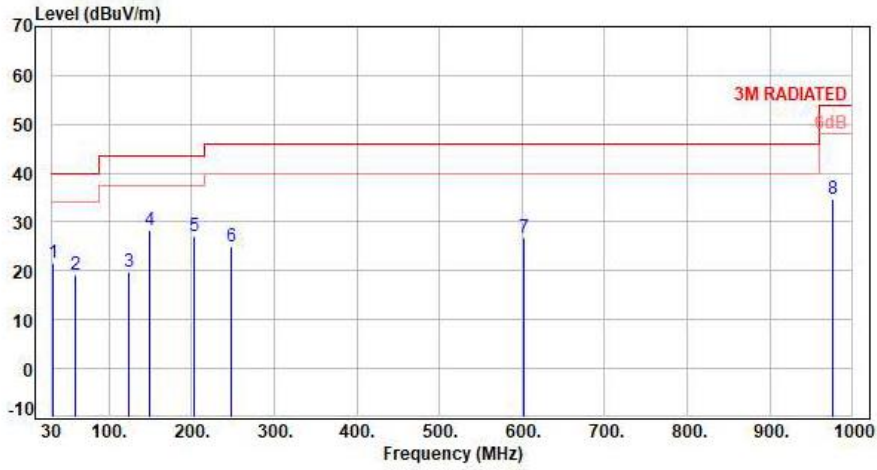

Table with 10 columns: No., Frequency (MHz), Factor (dB), Reading (dBuV), Level (dBuV/m), Limit (dBuV/m), Margin (dB), Detector, Height (cm), Azimuth (deg), P/F. Contains 8 rows of data.

Note: Level=Reading+Factor
Margin=Level-Limit
Factor=Antenna Factor + cable loss - Amplifier Factor



Test Mode : RFID 1TX 927.25MHz
Voltage : AC110V/60Hz From PowerSupply DC(5.2v/2A)
Pol : Horizontal



No.	Frequency (MHz)	Factor (dB)	Reading (dBuV)	Level (dBuV/m)	Limit (dBuV/m)	Margin (dB)	Detector	Height (cm)	Azimuth (deg)	P/F
1	31.94	-10.04	31.66	21.62	40.00	-18.38	Peak	400	360	P
2	59.10	-9.44	28.78	19.34	40.00	-20.66	Peak	400	360	P
3	123.12	-11.80	31.61	19.81	43.50	-23.69	Peak	400	360	P
4	148.34	-9.57	37.77	28.20	43.50	-15.30	Peak	400	360	P
5	202.66	-12.17	39.37	27.20	43.50	-16.30	Peak	400	360	P
6	247.28	-10.24	35.21	24.97	46.00	-21.03	Peak	400	360	P
7	602.30	-0.74	27.57	26.83	46.00	-19.17	Peak	400	360	P
8	976.72	4.94	29.77	34.71	54.00	-19.29	Peak	400	360	P

Note: Level=Reading+Factor
Margin=Level-Limit
Factor=Antenna Factor + cable loss - Amplifier Factor



6.6 Test Result and Data (1GHz ~ 25GHz)

Test Mode : RFID 1TX 902.75MHz
Voltage : AC110V/60Hz From PowerSupply DC(5.2v/2A)
Pol : Vertical

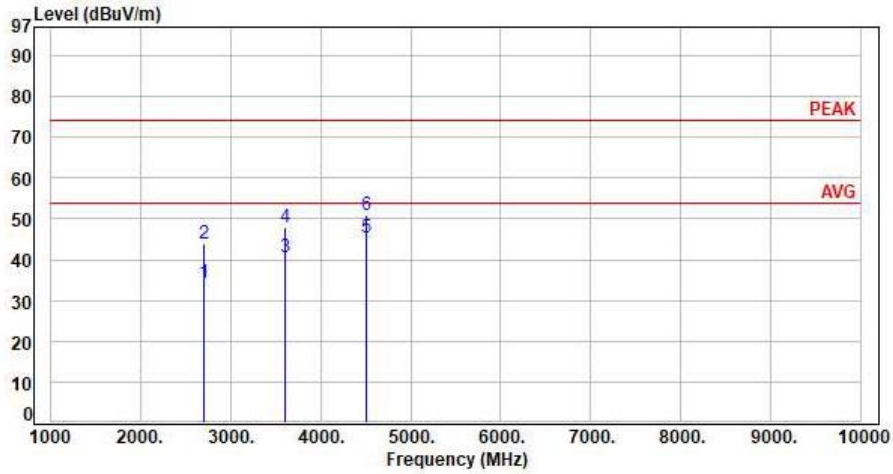

No.	Frequency (MHz)	Factor (dB)	Reading (dBuV)	Level (dBuV/m)	Limit (dBuV/m)	Margin (dB)	Detector	Height (cm)	Azimuth (deg)	P/F
1	2708.25	-0.99	35.45	34.46	54.00	-19.54	Average	153	6	P
2	2708.25	-0.99	45.01	44.02	74.00	-29.98	Peak	153	6	P
3	3611.00	2.80	37.67	40.47	54.00	-13.53	Average	100	204	P
4	3611.00	2.80	45.02	47.82	74.00	-26.18	Peak	100	204	P
5	4513.75	5.11	40.34	45.45	54.00	-8.55	Average	100	73	P
6	4513.75	5.11	45.66	50.77	74.00	-23.23	Peak	100	73	P

Note: Level=Reading+Factor
Margin=Level-Limit
Factor=Antenna Factor + cable loss - Amplifier Factor



Test Mode : RFID 1TX 902.75MHz
Voltage : AC110V/60Hz From PowerSupply DC(5.2v/2A)
Pol : Horizontal

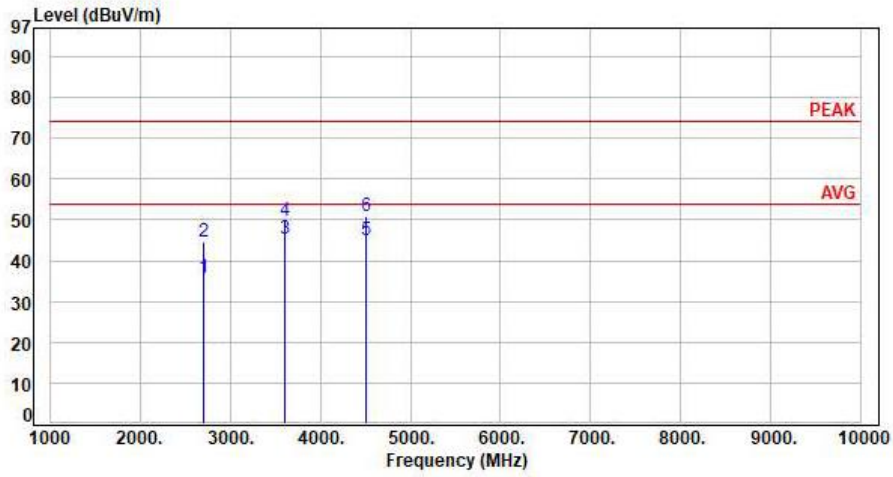

Table with 10 columns: No., Frequency (MHz), Factor (dB), Reading (dBuV), Level (dBuV/m), Limit (dBuV/m), Margin (dB), Detector, Height (cm), Azimuth (deg), P/F. Contains 6 rows of test data.

Note: Level=Reading+Factor
Margin=Level-Limit
Factor=Antenna Factor + cable loss - Amplifier Factor



Test Mode : RFID 1TX 914.75MHz
Voltage : AC110V/60Hz From PowerSupply DC(5.2v/2A)
Pol : Vertical

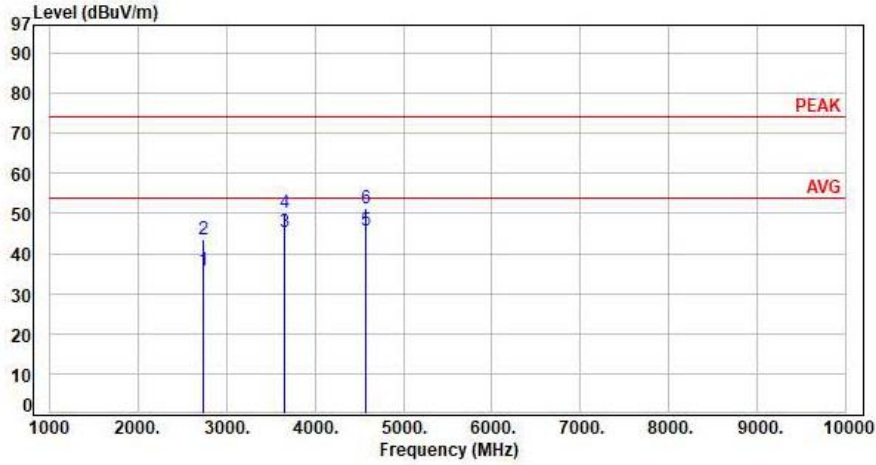
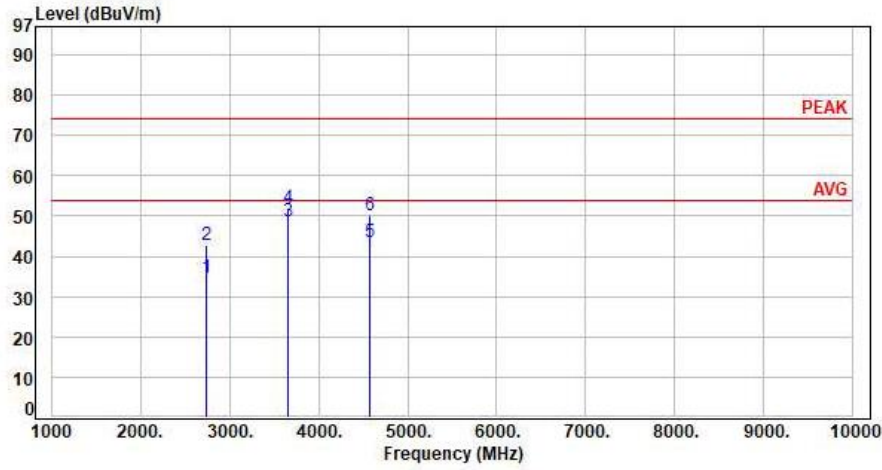

Table with 10 columns: No., Frequency (MHz), Factor (dB), Reading (dBuV), Level (dBuV/m), Limit (dBuV/m), Margin (dB), Detector, Height (cm), Azimuth P/F (deg). It contains 6 rows of test data.

Note: Level=Reading+Factor
Margin=Level-Limit
Factor=Antenna Factor + cable loss - Amplifier Factor



Test Mode : RFID 1TX 914.75MHz
 Voltage : AC110V/60Hz From PowerSupply DC(5.2v/2A)
 Pol : Horizontal



No.	Frequency (MHz)	Factor (dB)	Reading (dBuV)	Level (dBuV/m)	Limit (dBuV/m)	Margin (dB)	Detector	Height (cm)	Azimuth (deg)	P/F
1	2744.25	-0.95	35.66	34.71	54.00	-19.29	Average	100	180	P
2	2744.25	-0.95	43.61	42.66	74.00	-31.34	Peak	100	180	P
3	3659.00	3.13	45.62	48.75	54.00	-5.25	Average	243	33	P
4	3659.00	3.13	48.91	52.04	74.00	-21.96	Peak	243	33	P
5	4573.75	5.24	38.39	43.63	54.00	-10.37	Average	100	303	P
6	4573.75	5.24	44.76	50.00	74.00	-24.00	Peak	100	303	P

Note: Level=Reading+Factor
 Margin=Level-Limit
 Factor=Antenna Factor + cable loss - Amplifier Factor



Test Mode : RFID 1TX 927.25MHz
Voltage : AC110V/60Hz From PowerSupply DC(5.2v/2A)
Pol : Vertical

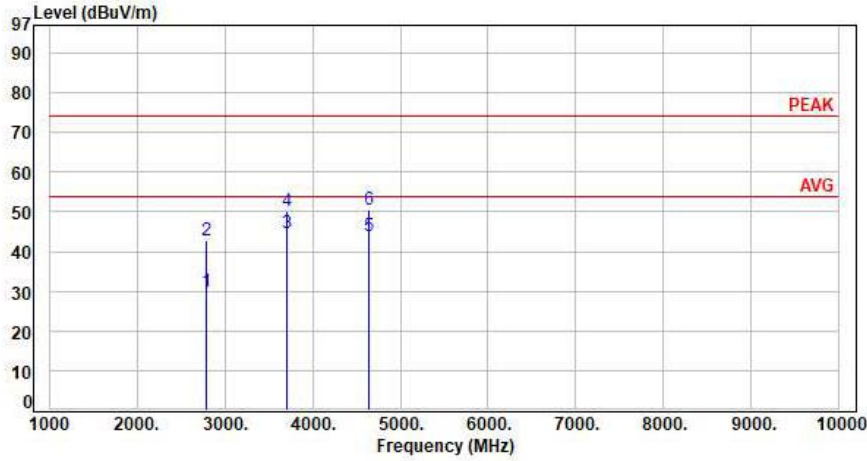
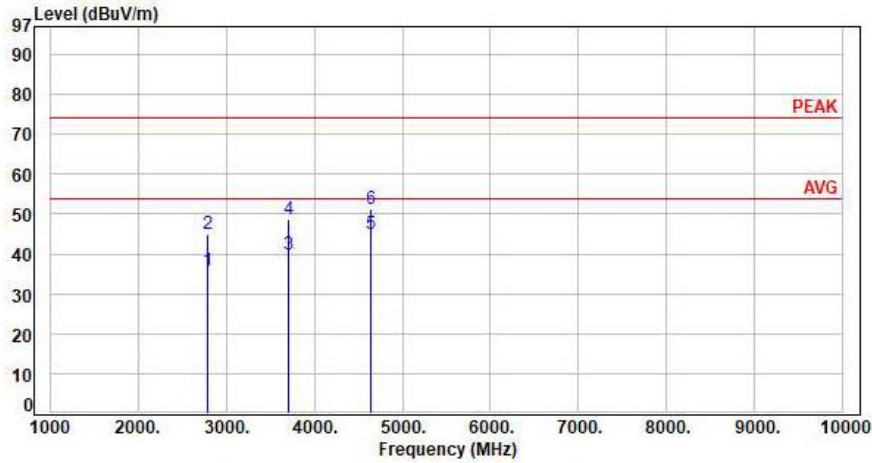

Table with 11 columns: No., Frequency (MHz), Factor (dB), Reading (dBuV), Level (dBuV/m), Limit (dBuV/m), Margin (dB), Detector, Height (cm), Azimuth (deg), P/F. It contains 6 rows of data corresponding to the peaks in the graph.

Note: Level=Reading+Factor
Margin=Level-Limit
Factor=Antenna Factor + cable loss - Amplifier Factor



Test Mode : RFID 1TX 927.25MHz
Voltage : AC110V/60Hz From PowerSupply DC(5.2v/2A)
Pol : Horizontal



No.	Frequency (MHz)	Factor (dB)	Reading (dBuV)	Level (dBuV/m)	Limit (dBuV/m)	Margin (dB)	Detector	Height (cm)	Azimuth (deg)	P/F
1	2781.75	-0.80	36.42	35.62	54.00	-18.38	Average	100	3	P
2	2781.75	-0.80	45.73	44.93	74.00	-29.07	Peak	100	3	P
3	3709.00	3.68	36.29	39.97	54.00	-14.03	Average	100	360	P
4	3709.00	3.68	45.03	48.71	74.00	-25.29	Peak	100	360	P
5	4636.25	5.44	39.61	45.05	54.00	-8.95	Average	387	58	P
6	4636.25	5.44	45.80	51.24	74.00	-22.76	Peak	387	58	P

Note: Level=Reading+Factor
Margin=Level-Limit
Factor=Antenna Factor + cable loss - Amplifier Factor



6.7 Restricted Bands of Operation

Only spurious emissions are permitted in any of the frequency bands listed below:

MHz	MHz	MHz	GHz
0.09000 – 0.11000	16.42000 – 16.42300	399.9 – 410.0	4.500 – 5.250
0.49500 – 0.505**	16.69475 – 16.69525	608.0 – 614.0	5.350 – 5.460
2.17350 – 2.19050	16.80425 – 16.80475	960.0 – 1240.0	7.250 – 7.750
4.12500 – 4.12800	25.50000 – 25.67000	1300.0 – 1427.0	8.025 – 8.500
4.17725 – 4.17775	37.50000 – 38.25000	1435.0 – 1626.5	9.000 – 9.200
4.20725 – 4.20775	73.00000 – 74.60000	1645.5 – 1646.5	9.300 – 9.500
6.21500 – 6.21800	74.80000 – 75.20000	1660.0 – 1710.0	10.600 – 12.700
6.26775 – 6.26825	108.00000 – 121.94000	1718.8 – 1722.2	13.250 – 13.400
6.31175 – 6.31225	123.00000 – 138.00000	2200.0 – 2300.0	14.470 – 14.500
8.29100 – 8.29400	149.90000 – 150.05000	2310.0 – 2390.0	15.350 – 16.200
8.36200 – 8.36600	156.52475 – 156.52525	2483.5 – 2500.0	17.700 – 21.400
8.37625 – 8.38675	156.70000 – 156.90000	2655.0 – 2900.0	22.010 – 23.120
8.41425 – 8.41475	162.01250 – 167.17000	3260.0 – 3267.0	23.600 – 24.000
12.29000 – 12.29300	167.72000 – 173.20000	3332.0 – 3339.0	31.200 – 31.800
12.51975 – 12.52025	240.00000 – 285.00000	3345.8 – 3358.0	36.430 – 36.500
12.57675 – 12.57725	322.00000 – 335.40000	3600.0 – 4400.0	Above 38.6
13.36000 – 13.41000			

** : Until February 1, 1999, this restricted band shall be 0.490-0.510 MHz



7. Test of Conducted Spurious Emission

7.1 Test Limit

According to the methods defined in ANSI C63.10-2013 Section 11.11.1
Below -20dB of the highest emission level of operating band (in 100kHz Resolution Bandwidth).

7.2 Test Procedure

According to the methods defined in ANSI C63.10-2013 Section 11.11.2 & 11.11.3

- a. The transmitter output was connected to the spectrum analyzer via a low loss cable.
- b. Set both RBW and VBW of spectrum analyzer to 100 KHz with convenient frequency span including 100 KHz bandwidth from band edge.
- c. The band edges was measured and recorded.

7.3 Test Setup Layout

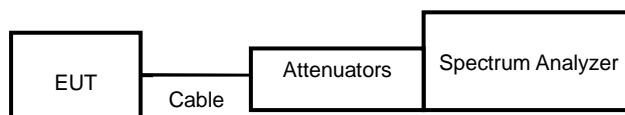

7.4 Test Result and Data

Note: Test plots refer to the following pages.



Modulation Type: ASK
CH01-1

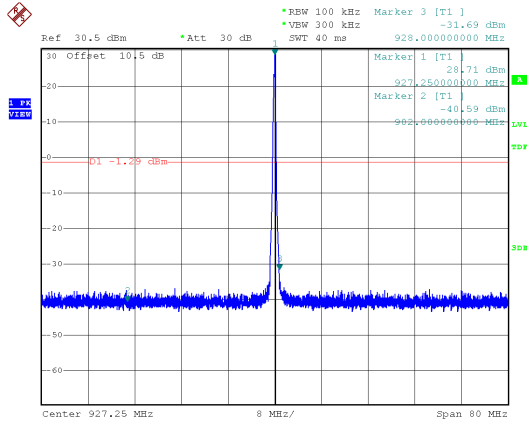

CH01-2

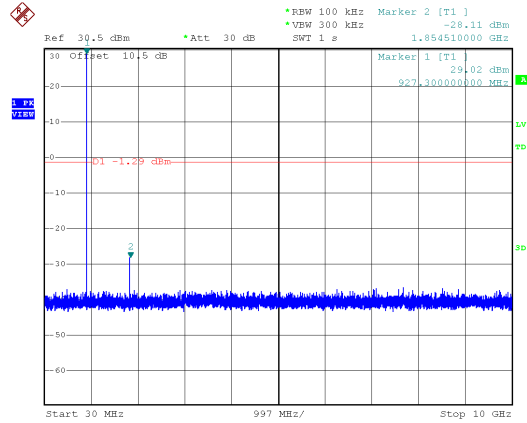

CH25-1

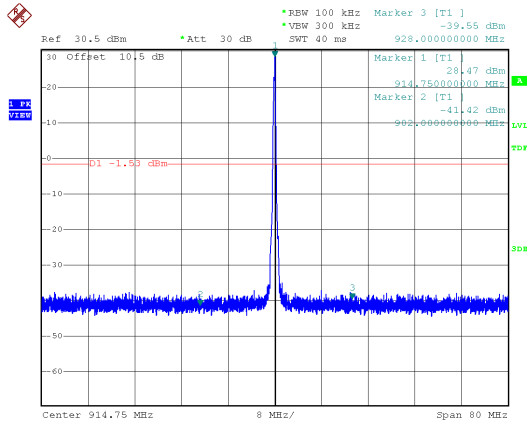

CH25-2

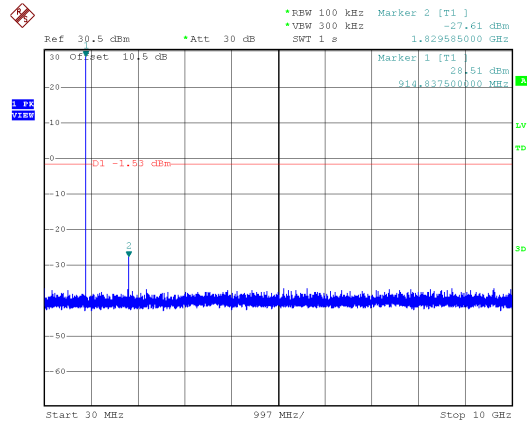

CH50-1

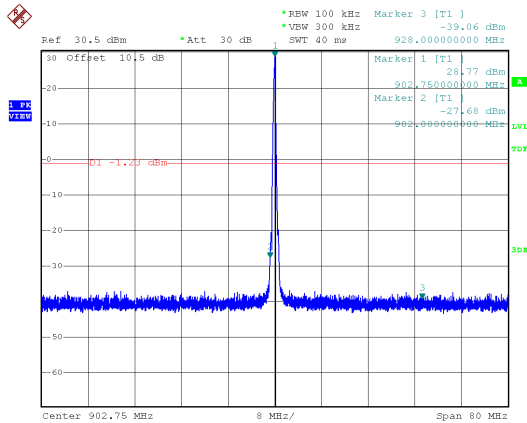

CH50-2

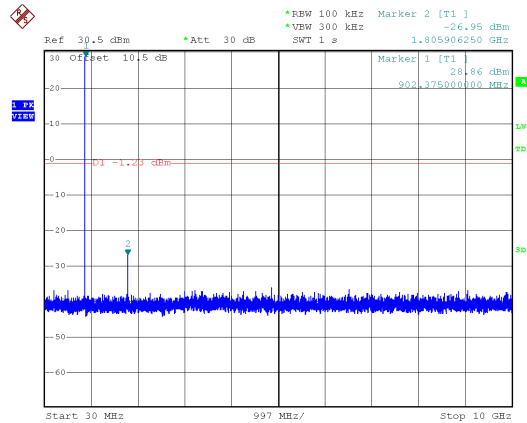



Modulation Type: ASK Hopping-1

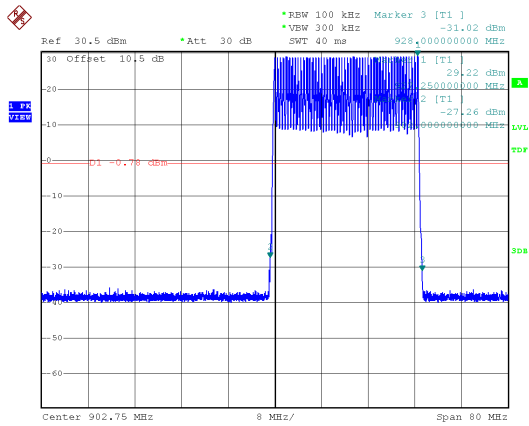

Hopping-2

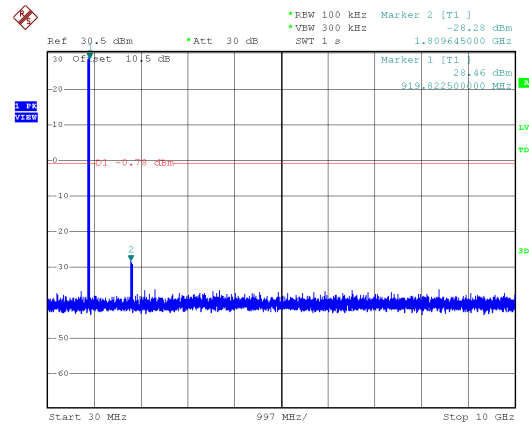



8. On Time, Duty Cycle and Measurement methods

8.1 Test Limit

None; for reporting purposes only.

8.2 Test Procedure

According to the methods defined in ANSI C63.10-2013 Section 11.6 Zero-Span Spectrum Analyzer Method.

8.3 Test Setup Layout

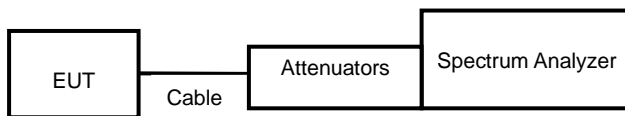

8.4 Test Result and Data

Modulation Mode	On Time (ms)	Period Time (ms)	Duty Cycle (%)
GFSK	203.00	208.00	97.60%

Modulation Type: ASK

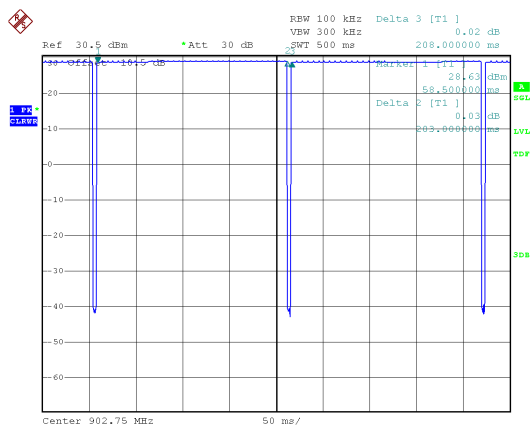



9. 20dB Bandwidth Measurement Data

9.1 Test Limit

The maximum allowed 20 dB bandwidth of the hopping channel is 500 kHz..

9.2 Test Procedures

According to the methods defined in ANSI C63.10-2013 Section 6.9

- a. The transmitter output was connected to the spectrum analyzer.
- b. Set RBW of spectrum analyzer to 10 KHz and VBW to 30 KHz.
- c. The 20 dB bandwidth is defined as the total spectrum the power of which is higher than peak power minus 20 dB.

9.3 Test Setup Layout

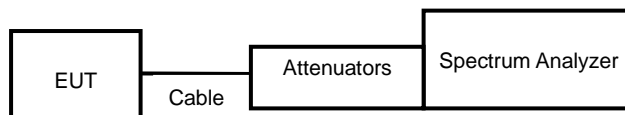

9.4 Test Result and Data

Modulation Type	Channel	Channel Frequency (MHz)	20dB Bandwidth (MHz)	Limit (MHz)
ASK	1	902.75	0.368	0.500
	25	914.75	0.368	0.500
	50	927.25	0.370	0.500



Modulation Type: ASK
CH01

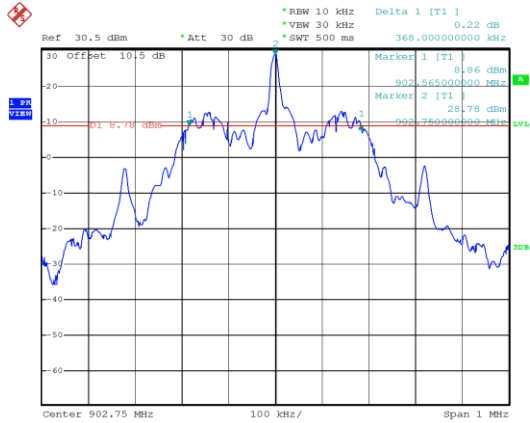

CH25

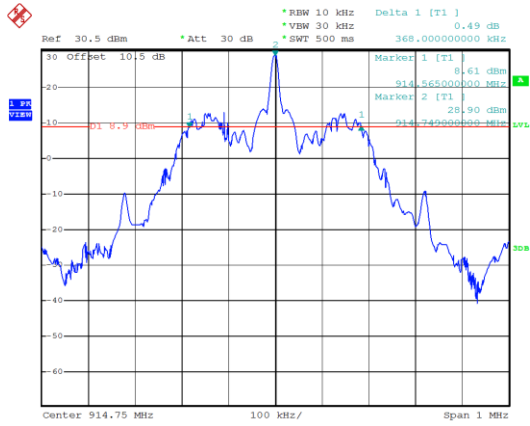

CH50

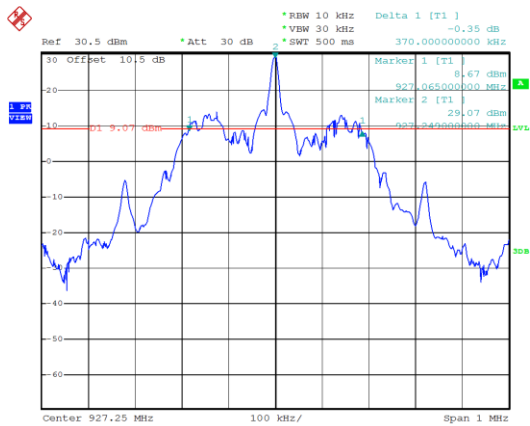



10. Frequencies Separation

10.1 Test Limit

Frequency hopping systems shall have hopping channel carrier frequencies separated by a minimum of 25 kHz or the 20 dB bandwidth of the hopping channel, whichever is greater.

10.2 Test Procedures

According to the methods defined in ANSI C63.10-2013 Section 7.8.2

- a. The transmitter output was connected to the spectrum analyzer.
- b. Set RBW of spectrum analyzer to 30 KHz and VBW to 100 KHz.
- c. By using the MaxHold function record the separation of two adjacent channels.
- d. Measure the frequency difference of these two adjacent channels.

10.3 Test Setup Layout

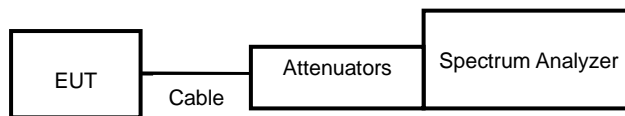

10.4 Test Result and Data

Modulation Type	Channel	Channel Frequency (MHz)	Channel Separation (MHz)	Limit (MHz)
ASK	1	902.75	0.50	0.368
	25	914.75	0.50	0.368
	50	927.25	0.50	0.37



Modulation Type: ASK
CH01

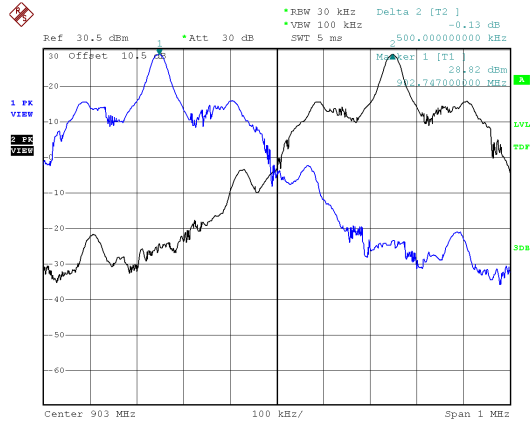

CH25

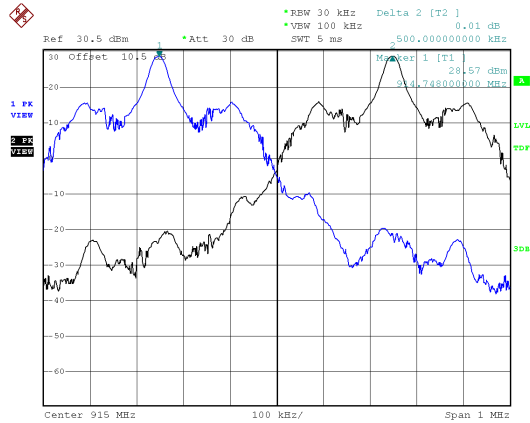

CH50

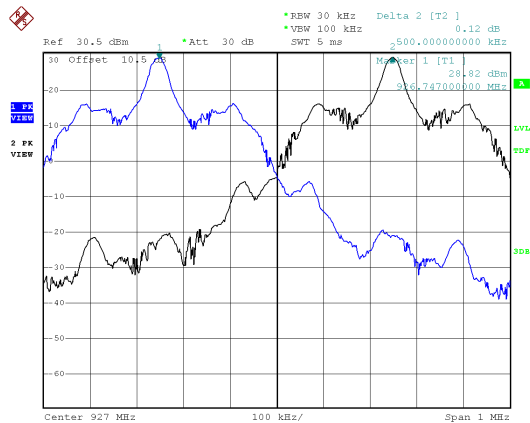



11. Dwell Time on each channel

11.1 Test Limit

The average time of occupancy on any channel shall not be greater than 0.4 seconds within a period of 0.4 seconds multiplied by the number of hopping channels employed.

11.2 Test Procedures

According to the methods defined in ANSI C63.10-2013 Section 7.8.4

1. The transmitter output was connected to the spectrum analyzer.
2. Adjust the center frequency to measure frequency, then set zero span mode.
2. Set RBW of spectrum analyzer to 1 MHz and VBW to 3 MHz.
4. Measure the time duration of one transmission on the measured frequency.

11.3 Test Setup Layout

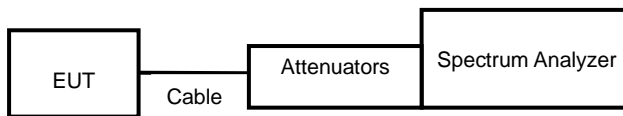

11.4 Test Result and Data

Channel	Channel Frequency (MHz)	Length of transmission time (ms)	Number of transmission in a 10s	Dwell Time (ms)	Limit (ms)
1	902.75	204.000	1.00	204.00	400
25	914.75	204.000	1.00	204.00	400
50	927.25	204.000	1.00	204.00	400



Modulation Type: ASK
CH01-1

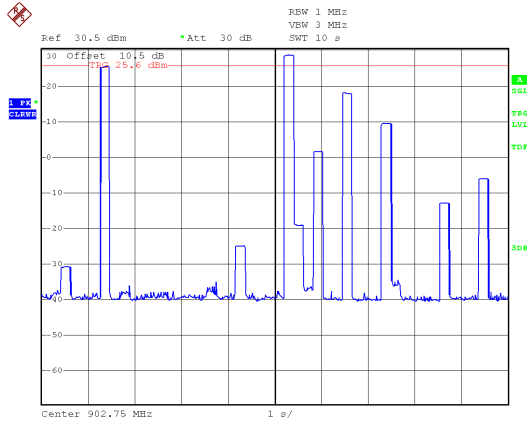

CH01-2

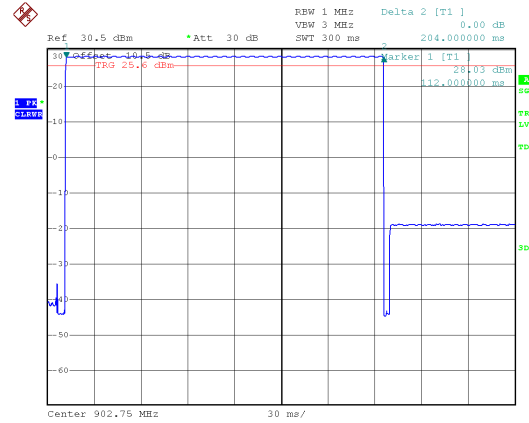

CH25-1

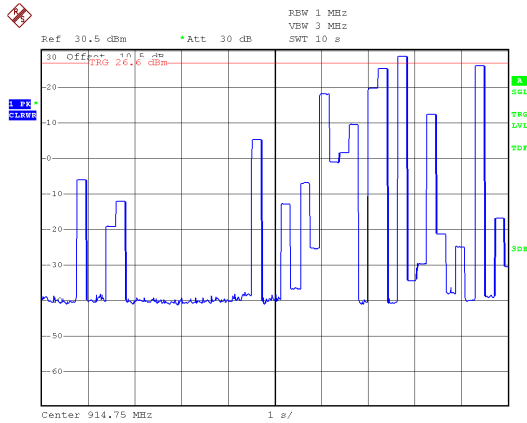

CH25-2

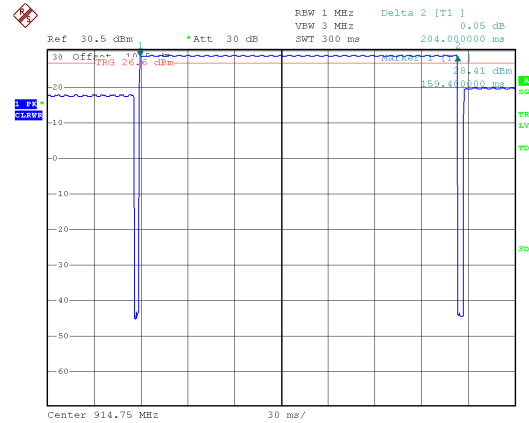

CH50-1

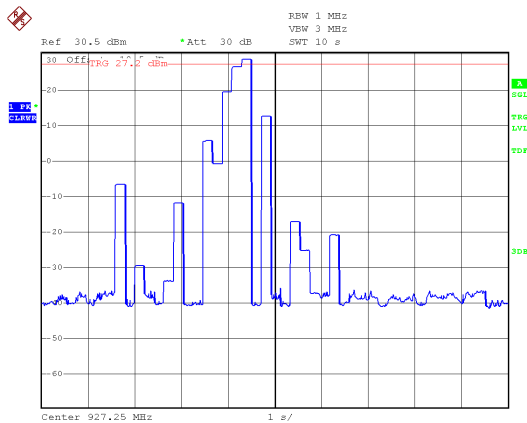

CH50-2

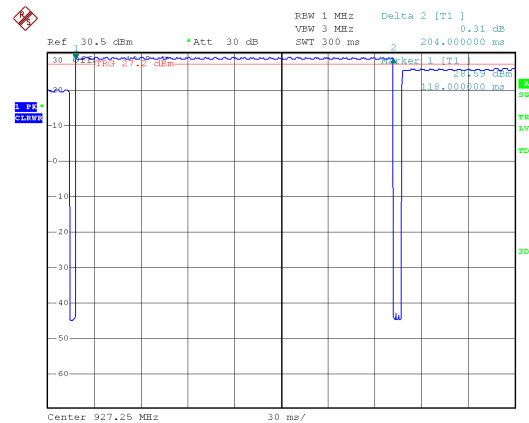



12. Number of Hopping Channels

12.1 Test Limit

Frequency hopping systems in the 902 ~ 928MHz band shall use at least 50 channels.

12.2 Test Procedures

According to the methods defined in ANSI C63.10-2013 Section 7.8.3

- a. The transmitter output was connected to the spectrum analyzer.
- b. 2. Set RBW of spectrum analyzer to 100 KHz and VBW to 300 KHz.
- c. 3. Set the MaxHold function, and then keep the EUT in hopping mode. Record all the signals from each channel until each one has been record.

12.3 Test Setup Layout

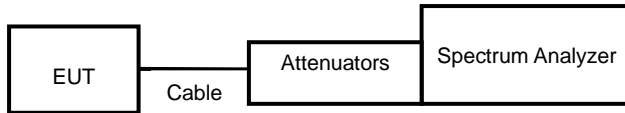

12.4 Test Result and Data

Modulation Type	Hopping Channels	Limit
ASK	50	25



Modulation Type: ASK

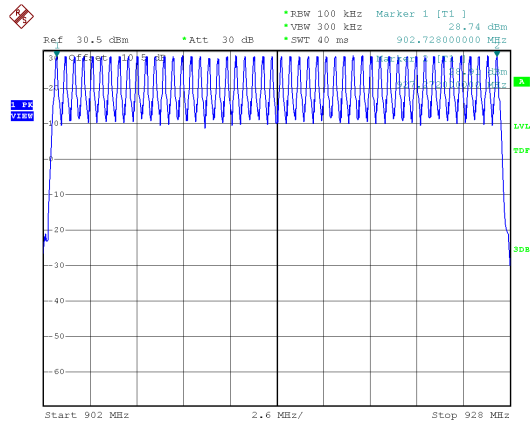



13. Maximum Peak Output Power

13.1 Test Limit

The Maximum Peak Output Power Measurement is 30dBm.

13.2 Test Procedures

According to the methods defined in ANSI C63.10-2013 Section 7.8.5

The antenna port(RF output)of the EUT was connected to the input(RF input)of a power meter.

Power was read directly from the meter and cable loss connection was added to the reading to obtain power at the EUT antenna terminal. The EUT Output Power was set to maximum to produce the worse case test result.

13.3 Test Setup Layout

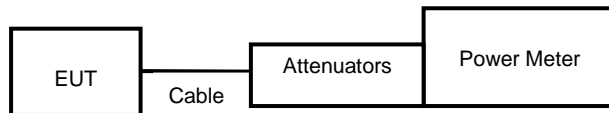



13.4 Test Result and Data

Port-1

Setting	Modulation Type	Channel	Channel Frequency (MHz)	AV Output Power (dBm)	AV Output Power (mW)
30	ASK	1	902.75	28.97	788.860
30		25	914.75	29.03	799.834
30		50	927.25	29.05	803.526

Port-2 -worst

Setting	Modulation Type	Channel	Channel Frequency (MHz)	AV Output Power (dBm)	AV Output Power (mW)
30	ASK	1	902.75	28.98	790.679
30		25	914.75	29.16	824.138
30		50	927.25	29.18	827.942

Port-3

Setting	Modulation Type	Channel	Channel Frequency (MHz)	AV Output Power (dBm)	AV Output Power (mW)
30	ASK	1	902.75	28.81	760.326
30		25	914.75	28.85	767.361
30		50	927.25	28.90	776.247

Port-4

Setting	Modulation Type	Channel	Channel Frequency (MHz)	AV Output Power (dBm)	AV Output Power (mW)
30	ASK	1	902.75	28.85	767.361
30		25	914.75	28.91	778.037
30		50	927.25	28.97	788.860