



Shenzhen CTA Testing Technology Co., Ltd.

Room 106, Building 1, Yibaolai Industrial Park, Qiaotou Community, Fuhai Street, Bao'an District, Shenzhen, China

### FCC PART 15 SUBPART C TEST REPORT

Report Reference No.....: CTA24070401302

FCC ID.....: 2BEUK-F43

Compiled by  
( position+printed name+signature) .: File administrators Jinghua Xiao

Supervised by  
( position+printed name+signature) .: Project Engineer Xudong Zhang

Approved by  
( position+printed name+signature) .: RF Manager Eric Wang

*Jinghua Xiao*  
*Xudong Zhang*  
**CTA**  
*approved*  
*Eric Wang*

Date of issue .....: Jul. 11, 2024

Testing Laboratory Name.....: Shenzhen CTA Testing Technology Co., Ltd.

Address.....: Room 106, Building 1, Yibaolai Industrial Park, Qiaotou Community, Fuhai Street, Bao'an District, Shenzhen, China

Applicant's name.....: Shenzhen Fenjun New Energy Co., Ltd

Address.....: 7th Floor, Building A2, Xinghuaxiong Science and Technology Park, Baihua Community, Guangming Street, Guangming New District, Shenzhen, China

Test specification .....: FCC CFR 47 PART 1, § 1.1310

Standard.....: KDB 680106 D01 Wireless Power Transfer v04

**Shenzhen CTA Testing Technology Co., Ltd. All rights reserved.**

This publication may be reproduced in whole or in part for non-commercial purposes as long as the Shenzhen CTA Testing Technology Co., Ltd. is acknowledged as copyright owner and source of the material. Shenzhen CTA Testing Technology Co., Ltd. takes no responsibility for and will not assume liability for damages resulting from the reader's interpretation of the reproduced material due to its placement and context.

Test item description .....: MINI PORTABLE CHARGER

Manufacturer .....: Shenzhen Fenjun New Energy Co., Ltd

Model/Type reference .....: F43

Modulation Type.....: ASK

Operation Frequency.....: From 110KHz~205KHz

Rating .....: DC 3.7V From battery

Rating .....: Input: DC 5V-1A

Rating .....: Wireless output(Watch): 3W (MAX)

Result .....: PASS

Shenzhen CTA Testing Technology Co., Ltd.

Room 106, Building 1, Yibaolai Industrial Park, Qiaotou Community, Fuhai Street, Bao'an District, Shenzhen, China

Tel:+86-755 2322 5875 E-mail:cta@cta-test.cn Web:http://www.cta-test.cn

# TEST REPORT

Equipment under Test : MINI PORTABLE CHARGER

Model /Type : F43

Listed Models : S9

**Applicant** : **Shenzhen Fenjun New Energy Co., Ltd**

Address : 7th Floor, Building A2, Xinghuaxiong Science and Technology Park,  
Baihua Community, Guangming Street, Guangming New District,  
Shenzhen, China

**Manufacturer** : **Shenzhen Fenjun New Energy Co., Ltd**

Address : 7th Floor, Building A2, Xinghuaxiong Science and Technology Park,  
Baihua Community, Guangming Street, Guangming New District,  
Shenzhen, China

<b>Test Result:</b>	<b>PASS</b>
---------------------	-------------

The test report merely corresponds to the test sample.

It is not permitted to copy extracts of these test result without the written permission of the test laboratory.

**Shenzhen CTA Testing Technology Co., Ltd.**

Room 106, Building 1, Yibaolai Industrial Park, Qiaotou Community, Fuhai Street, Bao'an District, Shenzhen, China

Tel:+86-755 2322 5875 E-mail:cta@cta-test.cn Web:http://www.cta-test.cn

## Contents

<b>1</b>	<b><u>TEST STANDARDS</u></b>	<b>4</b>
<b>2</b>	<b><u>SUMMARY</u></b>	<b>5</b>
2.1	General Remarks	5
2.2	Product Description	5
2.3	Description of the test mode	5
2.4	Special Accessories	5
2.5	Modifications	5
<b>3</b>	<b><u>TEST ENVIRONMENT</u></b>	<b>6</b>
3.1	Address of the test laboratory	6
3.2	Test Facility	6
3.3	Statement of the measurement uncertainty	6
3.4	Equipments Used during the Test	6
<b>4</b>	<b><u>TEST LIMIT</u></b>	<b>7</b>
4.1	Requirement	7
4.2	Test setup	7
4.3	Test Procedures	9
4.4	Equipment Approval Considerations of KDB 680106 D01v04	9
4.5	Test results	10
4.6	Conclusion	11
<b>5</b>	<b><u>PHOTOGRAPHS OF THE TEST SETUP</u></b>	<b>12</b>

Shenzhen CTA Testing Technology Co., Ltd.

Room 106, Building 1, Yibaolai Industrial Park, Qiaotou Community, Fuhai Street, Bao'an District, Shenzhen, China

Tel:+86-755 2322 5875 E-mail:cta@cta-test.cn Web:http://www.cta-test.cn

# **1 TEST STANDARDS**

The tests were performed according to following standards:

[680106 D01 Wireless Power Transfer v04](#): EQUIPMENT AUTHORIZATION OF WIRELESS POWER TRANSFER DEVICES.

## 2 SUMMARY

### 2.1 General Remarks

Date of receipt of test sample	:	Jul. 03, 2024
Testing commenced on	:	Jul. 03, 2024
Testing concluded on	:	Jul. 11, 2024

### 2.2 Product Description

Product Name:	MINI PORTABLE CHARGER
Model/Type reference:	F43
Hardware version:	V1.0
Software version:	V1.0
Test samples ID:	CTA240704013-1# (Engineer sample) CTA240704013-2# (Normal sample)
Power supply:	DC 3.7V From battery Input: DC 5V-1A Wireless output(Watch): 3W (MAX)
Adapter information (Auxiliary test supplied by test Lab):	Model: MDY-11-EX Input: AC 100-240V 50/60H ,0.4A 12W Output: DC 5V3A, DC 9V3A, DC12V2.25A, DC 20V1.35A, DC11V3A,
Operation frequency:	110KHz - 205KHz
Modulation type:	ASK
Antenna type:	Loop coil antenna

### 2.3 Description of the test mode

Equipment under test was operated during the measurement under the following conditions:

Charging and communication mode

Test Modes:		
Mode 1	Wireless output(3W)	Recorded
Mode 2	Standby	Pre-tested

### 2.4 Special Accessories

The following is the EUT test of the auxiliary equipment provided by the laboratory:

Description	Manufacturer	Model	Technical Parameters	Certificate	Provided by
Wireless charging load	/	/	3W	/	Lab

### 2.5 Modifications

No modifications were implemented to meet testing criteria.

**Shenzhen CTA Testing Technology Co., Ltd.**

Room 106, Building 1, Yibaolai Industrial Park, Qiaotou Community, Fuhai Street, Bao'an District, Shenzhen, China

Tel:+86-755 2322 5875 E-mail:cta@cta-test.cn Web:http://www.cta-test.cn

### 3 TEST ENVIRONMENT

#### 3.1 Address of the test laboratory

**Shenzhen CTA Testing Technology Co., Ltd.**  
Room 106, Building 1, Yibaolai Industrial Park, Qiaotou Community,  
Fuhai Street, Bao'an District, Shenzhen, China

#### 3.2 Test Facility

The test facility is recognized, certified, or accredited by the following organizations:  
**FCC-Registration No.: 517856 Designation Number: CN1318**

Shenzhen CTA Testing Technology Co., Ltd. has been listed on the US Federal Communications Commission list of test facilities recognized to perform electromagnetic emissions measurements.

#### A2LA-Lab Cert. No.: 6534.01

Shenzhen CTA Testing Technology Co., Ltd. has been listed by American Association for Laboratory Accreditation to perform electromagnetic emission measurement.  
The 3m-Semi anechoic test site fulfils CISPR 16-1-4 according to ANSI C63.10 and CISPR 16-1-4:2010.

#### 3.3 Statement of the measurement uncertainty

Test	Measurement Uncertainty	Notes
Magnetic field measurement (9kHz~30MHz)	±7.8 %	(1)
Electric field measurements (9kHz~ 30MHz)	±7.8 %	(1)

(1) This uncertainty represents an expanded uncertainty expressed at approximately the 95% confidence level using a coverage factor of k=2.

#### 3.4 Equipments Used during the Test

Test Equipment	Manufacturer	Model No.	SN.	Cal.Date (mm-dd-yy)	Cal.Due date (mm-dd-yy)
Exposure Level Tester	Narda	ELT-400	N-0231	June 24 2024	June 23 2025
Magnetic field probe 100cm2	Narda	ELT probe 100cm2	M0675	June 24 2024	June 23 2025

**Shenzhen CTA Testing Technology Co., Ltd.**

Room 106, Building 1, Yibaolai Industrial Park, Qiaotou Community, Fuhai Street, Bao'an District, Shenzhen, China

Tel:+86-755 2322 5875 E-mail:cta@cta-test.cn Web:http://www.cta-test.cn



## 4 Test limit

### 4.1 Requirement

§1.1310: The criteria listed in the following table shall be used to evaluate the environment impact of human exposure to radio frequency (RF) radiation as specified in §1.1307(b), except in the case of portable devices which shall be evaluated according to the provisions of FCC part 2.1093 of this chapter.

**Table 1 to §1.1310(e)(1) - Limits for Maximum Permissible Exposure (MPE)**

Frequency range (MHz)	Electric field strength (V/m)	Magnetic field strength (A/m)	Power density (mW/cm <sup>2</sup> )	Averaging time (minutes)
(i) Limits for Occupational/Controlled Exposure				
0.3-3.0	614	1.63	*(100)	≤6
3.0-30	1842/f	4.89/f	*(900/f <sup>2</sup> )	<6
30-300	61.4	0.163	1.0	<6
300-1500	/	/	f/300	<6
1500-100000	/	/	5	<6
(ii) Limits for General Population/Uncontrolled Exposure				
0.3-1.34	614	1.63	*(100)	<30
1.34-30	824/f	2.19/f	*(180/f <sup>2</sup> )	<30
30-300	27.5	0.073	0.2	<30
300-1500	/	/	f/1500	<30
1500-100000	/	/	1.0	<30

f = frequency in MHz

\* = Plane-wave equivalent power density

**Note 1:** Occupational/controlled exposure limits apply in situations in which persons are exposed as a consequence of their employment provided those persons are fully aware of the potential for exposure and can exercise control over their exposure.

**Note 2:** General population/uncontrolled exposure limits apply in situations in which the general public may be exposed, or in which persons who are exposed as a consequence of their employment may not be fully aware of the potential for exposure or cannot exercise control over their exposure.

### 4.2 Test setup

For mobile exposure conditions:

**Shenzhen CTA Testing Technology Co., Ltd.**

Room 106, Building 1, Yibaolai Industrial Park, Qiaotou Community, Fuhai Street, Bao'an District, Shenzhen, China

Tel:+86-755 2322 5875 E-mail:cta@cta-test.cn Web:http://www.cta-test.cn

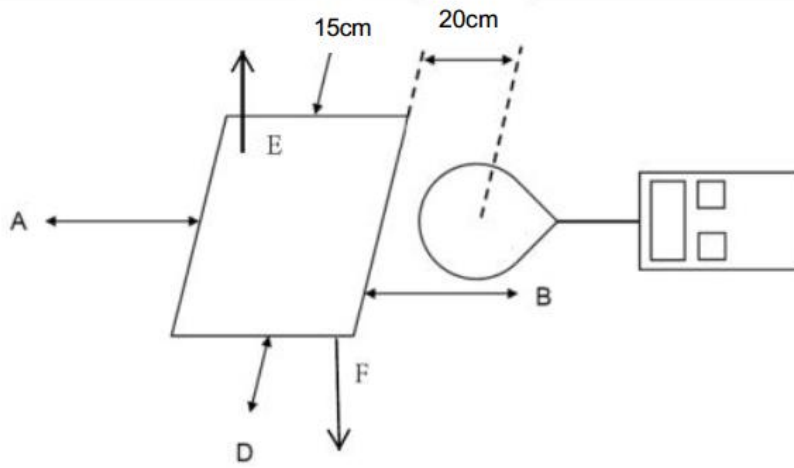

Note: The distance of the points A/B/C/D is 15cm, and the point E is 20cm.

For portable exposure conditions:

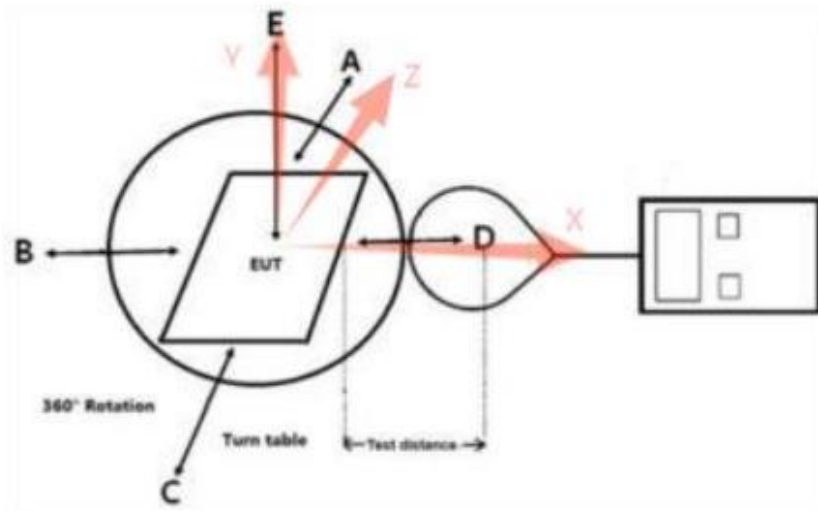

Note: The distance of the points A/B/C/D/E/F is 0,2,4,6,8,10,12,14,16,18, 20cm. The values tested by the probe are X, Y, and Z on three axes perpendicular to the edge of the device. Top and bottom side coincident with the axis(Y) of the main coil.

**Shenzhen CTA Testing Technology Co., Ltd.**

Room 106, Building 1, Yibaolai Industrial Park, Qiaotou Community, Fuhai Street, Bao'an District, Shenzhen, China

Tel:+86-755 2322 5875 E-mail:cta@cta-test.cn Web:http://www.cta-test.cn



### 4.3 Test Procedures

#### For mobile exposure conditions:

- The RF exposure test was performed in anechoic chamber.
- E and H-field measurements should be made with the center of the probe at a distance of 15 cm surrounding the EUT and 20 cm above the top surface of the primary/client pair.
- The highest emission level was recorded and compared with limit.
- The EUT was measured according to the KDB 680106 D01 Wireless Power Transfer v04.

#### For portable exposure conditions:

- The RF exposure test was performed in anechoic chamber.
- Perform H-field measurements for each edge/top surface of the host/client pair at every 2 cm, starting from as close as possible out to 20 cm
- The highest emission level was recorded and compared with limit.
- The EUT was measured according to the KDB 680106 D01 Wireless Power Transfer v04.

### 4.4 Equipment Approval Considerations of KDB 680106 D01v04

Requirements of KDB 680106 D01	Description
WPT operating frequency (or frequencies).	The device operate in the frequency range 110KHz~205KHz
Number of radiating structure(Coil)	Only one radiated Coil
Conducted power for each radiating structure.	Maximum 3W
§ 2.1091-Mobile or § 2.1093-Portable demonstrated scenarios of operation, including RF exposure compliance information	Mobile and Portable Device
Maximum distance from the WPT transmitter at which, by design, a load can be charged (including slow-charging operations)	Charing with the load directly contact

## 4.5 Test results

For portable exposure condition:

- (1). The portable test modes have covered the considerations of the mobile test, only record the test data of the portable conditions in this report.
- (2) Operating modes with client device (1 %, 50%, 99% battery status of client device) have been test, only show the data of worst case of 1% battery status of client device.
- (3) Test performed with all the radiating structures operating at maximum power at the same time.
- (4) H-field measurements are taken along all three axes the device from 0cm~20cm in 2cm minimum increment for each edge surface of the host/client pair. **If the center of the probe sensing element is more than 5mm from the probe outer edge, the field strengths need to be estimated for the positions that are not reachable.**
- (5) According to Calibration information and specification about ETL-400 Probe, The Probe ETL-400 Probe's sensitive elements center is located in the probe's center, and **the distance from the sensitive elements center to the tip of probe is 6.25cm.**
- (6) The actual 0cm, 2cm, 4cm and 6cm field strengths need to be estimated for the positions that are not reachable via numerical calculation.
- (7) Use **Biot-Savart formula** theory to estimate the strength of the magnetic field that the measuring instrument cannot measure. According to Biot-Savart formula:

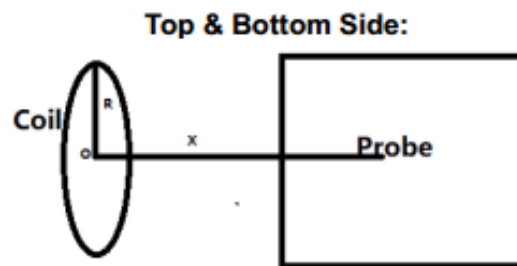

$$B = \frac{\mu_0 * I * N * R^2}{2 * (R^2 + x^2)^{3/2}}$$

**Front, left, right & rear Side:**

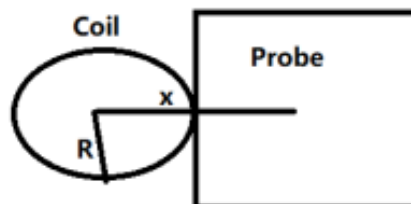

$$B = \frac{\mu_0 * I * N}{2 * x}$$

**B(Unit:A/m):** means H-field value;

$\mu_0$  is space permeability;  $\mu_0=4\pi*10^{-7}$ ;

**I(Unit:A):** A current element passing through a radiated coil;

**R(Unit:m):** means the Radius of radiated coil, According to provided Antenna specification:

$R=20/2=10\text{mm}=0.01\text{m}$ ;

**Test Distance(Unit:m):** The distance from the sensing element of the probe to the edge of the device surface.

**x(Unit:m):** means the center of the coil to the sensing elements of the probe. (For top & bottom side:  $x=\text{test distance}$ ; For other side:  $x=\text{test distance}+R$ )

**N:** Number of turns, according to providing "Antenna specification" files:  $N=10$ .

**Shenzhen CTA Testing Technology Co., Ltd.**

Room 106, Building 1, Yibaolai Industrial Park, Qiaotou Community, Fuhai Street, Bao'an District, Shenzhen, China

Tel:+86-755 2322 5875 E-mail:cta@cta-test.cn Web:http://www.cta-test.cn

(8) For validation purposes: If the value to show a 30% agreement between the mode and the probe measurements for the two closest points to the device surface, and with 2cm increments. Then this extrapolation method is reasonable.

**4.5.1 Validation results for the numerical calculation model**

- a) Measure with probe directed contact(test distace:6.25cm)
- b) Using Biot-Savart formula to calculate estimated results at test distace of 8cm and 10 cm;
- c) measure at test distace of 8 cm and 10cm;
- d) Compares the estimated results and measured result, the varation should not be greater than 30%;

Conclusion: The numerical calculation model is valid.

Distance(cm)	Test condition: Mode 1																	
	Top			Bottom			Left			Right			Front			back		
	Mea.	Est.	Var.	Mea.	Est.	Var.	Mea.	Est.	Var.	Mea.	Est.	Var.	Mea.	Est.	Var.	Mea.	Est.	Var.
6.25	0.0053	/	/	0.0042	/	/	0.0021	/	/	0.0024	/	/	0.0019	/	/	0.0023	/	/
8	0.0023	0.0026	15.2	0.0019	0.002	5.2	0.0016	0.0017	7.3	0.0016	0.0019	16.7	0.0016	0.0015	-4.6	0.0019	0.0019	-1.6
10	0.0011	0.0013	15.1	0.001	0.001	-3.0	0.0013	0.0014	8.4	0.0014	0.0016	17.2	0.0015	0.0013	-12.4	0.0017	0.0015	-11.4

Mea.-Measured H-field(A/m); Est. - Estimated H-field(A/m);  
Var. - Variation between measured and estimated value(%);

**4.5.1 Final H-Field Emission level with a combination of measured and estimated results.**

Test condition: Mode 1

Distance(cm)	Type	Result(A/m)						Limit(A/m)
		Top	Bottom	Left	Right	Front	back	
0	Estimate	1.3439	1.065	0.0152	0.0174	0.0138	0.0167	1.63
2	Estimate	0.1202	0.0953	0.0051	0.0058	0.0046	0.0056	1.63
4	Estimate	0.0192	0.0152	0.003	0.0035	0.0028	0.0033	1.63
6	Estimate	0.006	0.0047	0.0022	0.0025	0.002	0.0024	1.63
8	Measured	0.0023	0.0019	0.0016	0.0016	0.0016	0.0019	1.63
10	Measured	0.0011	0.001	0.0013	0.0014	0.0015	0.0017	1.63
12	Measured	0.0008	0.0005	0.0011	0.0012	0.0012	0.0012	1.63
14	Measured	0.0005	0.0004	0.0011	0.0012	0.0009	0.0012	1.63
16	Measured	0.0003	0.0003	0.0010	0.0009	0.0008	0.0010	1.63
18	Measured	0.0002	0.0002	0.0009	0.0009	0.0006	0.0008	1.63
20	Measured	0.0002	9E-05	0.0006	0.0007	0.0008	0.0009	1.63

**4.6 Conclusion**

A minimum safety distance of 0 cm to the antenna is required when the device is charging a smart phone for portable exposure. The detected emissions are below the limitations according FCC KDB 680106 and confirmed by the FCC according to KDB Inquire..

## 5 Photographs of the Test Setup

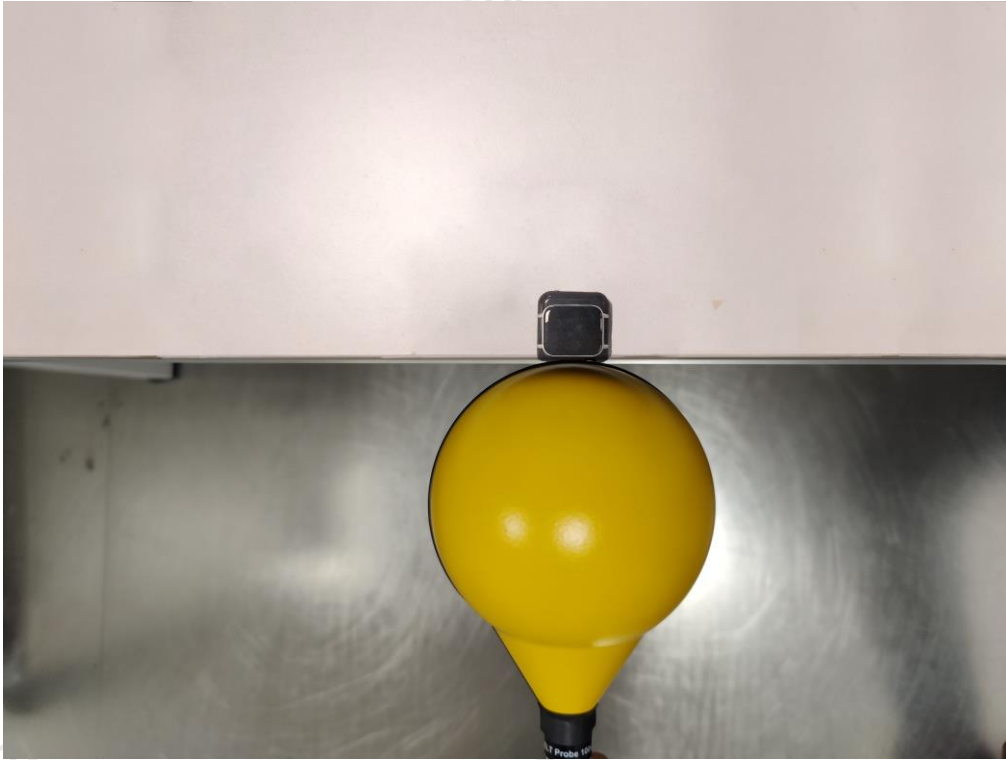

\*\*\*\*\* End of Report \*\*\*\*\*

**Shenzhen CTA Testing Technology Co., Ltd.**

Room 106, Building 1, Yibaolai Industrial Park, Qiaotou Community, Fuhai Street, Bao'an District, Shenzhen, China

Tel:+86-755 2322 5875 E-mail:cta@cta-test.cn Web:http://www.cta-test.cn