

TEST REPORT



Applicant:	Dongguan Pinhe electronic Technology Co., LTD		
Address:	No. 1, Baisha Eighth Street, Langbei Village, Changping Town, Dongguan City, Guangdong Province. China		
Manufacturer:	Dongguan Pinhe electronic Technology Co., LTD		
Address:	No. 1, Baisha Eighth Street, Langbei Village, Changping Town, Dongguan City, Guangdong Province. China		
Factory:	Dongguan Pinhe electronic Technology Co., LTD		
Address:	No. 1, Baisha Eighth Street, Langbei Village, Changping Town, Dongguan City, Guangdong Province. China		
E.U.T.:	Remote Control		
Model Number:	PH-2.4G-K4		
Trade mark:	----		
FCC ID:	2BETQ-K4		
Date of Receipt:	Jan. 22, 2024	Date of Test:	Jan. 22, 2024 - Jan. 28, 2024
Test Specification:	FCC 47 CFR Part 15, Subpart C		
Test Result:	The equipment under test was found to be compliance with the requirements of the standards applied.		
Prepared by:	Approved & Authorized Signer:		
			
_____	_____		
Jerry Hu/ Engineer	Frank Shen/ Manager		
	Issue Date: February 1, 2024		
This test report is based on a single evaluation of one sample of above mentioned products. It is not permitted to be duplicated in extracts without written approval of Dongguan Lepont Service Co., Ltd.			

TABLE OF CONTENTS

1. GENERAL PRODUCT INFORMATION	4
1.1. PRODUCT FUNCTION.....	4
1.2. EUT TECHNICAL DESCRIPTION.....	4
1.3. INDEPENDENT OPERATION MODES	5
2. TEST STANDARDS AND SITES	6
2.1. DESCRIPTION OF STANDARDS AND RESULTS.....	6
2.2. LIST OF TEST AND MEASUREMENT INSTRUMENTS	7
2.3. MEASUREMENT UNCERTAINTY	8
2.4. TEST FACILITY	9
3. SETUP OF EQUIPMENT UNDER TEST	10
3.1. RADIO FREQUENCY TEST SETUP 1	10
3.2. RADIO FREQUENCY TEST SETUP 2	10
3.3. CONDUCTED EMISSION TEST SETUP	12
3.4. BLOCK DIAGRAM CONFIGURATION OF TEST SYSTEM	12
4. TEST RESULTS AND MEASUREMENT DATA	13
4.1. BANDWIDTH TEST.....	13
4.2. RADIATED SPURIOUS EMISSION.....	17
4.3. BAND EDGES REQUIREMENT	23
4.4. ANTENNA APPLICATION	25

1. GENERAL PRODUCT INFORMATION

1.1. PRODUCT FUNCTION

Refer to Technical Construction Form and User Manual.

1.2. EUT TECHNICAL DESCRIPTION

Product Name:	Remote Control
Model No.:	PH-2.4G-K4
Test Model No:	PH-2.4G-K4
Test sample(s) ID:	LP23080282C01-S001
Sample(s) Status	Engineer sample
Hardware:	N/A
Software:	N/A
Operation Frequency:	2405~ 2470 MHz
Channel numbers:	3
Modulation type:	GFSK
Antenna Type:	PCB Antenna
Antenna gain:	-1.0dBi
Power supply:	DC 3.0V

1.3. INDEPENDENT OPERATION MODES

The EUT has been tested under its typical operating condition.
The EUT configuration for testing is installed on RF field strength measurement to meet the Commissions requirement and operating in a manner which intends to maximize its emission characteristics in a continuous normal application.

The Transmitter was operated in the normal operating mode. The TX frequency was fixed which was for the purpose of the measurements.

Test of channel included the lowest and middle and highest frequency to perform the test, then record on this report.

Pre-defined engineering program for regulatory testing used to control the EUT for staying in continuous transmitting and receiving mode is programmed.

Frequency and Channel list for GFSK

Channel No .	Frequency (MHz)	Channel No .	Frequency (MHz)
1	2405	2	2430
3	2470		

2. TEST STANDARDS AND SITES

2.1. DESCRIPTION OF STANDARDS AND RESULTS

The EUT have been tested according to the applicable standards as referenced below.

FCC Part Clause	Test Parameter	Verdict	Remark
15.207	Conducted Emission	N/A	
15.209	Radiated Emission	PASS	
15.249	Radiated Spurious Emission	PASS	
15.249	Band edge test	PASS	
15.215	20dB Bandwidth	PASS	
15.203	Antenna Requirement	PASS	

NOTE1: N/A (Not Applicable)

NOTE2: The report use radiated measurements in the restricted frequency bands. In addition, the radiated test is also performed to ensure the emissions emanating from the device cabinet also comply with the applicable limits.

RELATED SUBMITTAL(S) / GRANT(S):

This submittal(s) (test report) is intended for FCC ID: 2BETQ-K4 filing to comply with Section 15.249 of the FCC Part 15, Subpart C Rules.

2.2. LIST OF TEST AND MEASUREMENT INSTRUMENTS

For conducted emission at the mains terminals test(Shielded Room 2)							
Equipment	Manufacturer	Model No.	Serial No.	Last Cal.	Cal. Interval	Lab No.	Remark
EMI Test Receiver	Rohde & Schwarz	ESCS30	1002.4500	Feb. 15, 2023	1 Year	LEP-E004	<input checked="" type="checkbox"/>
Artificial Mains Network	Rohde & Schwarz	ENV216	100873	Feb. 15, 2023	1 Year	LEP-E001	<input checked="" type="checkbox"/>
Artificial Mains Network	Schwarzbeck	NSLK 8128	NSLK 8128-249	Feb. 15, 2023	1 Year	LEP-E047	<input type="checkbox"/>
Pulse Limiter	Schwarzbeck	VYSD9561-F-N	00612	Feb. 15, 2023	1 Year	LEP-E047	<input type="checkbox"/>
ISN	Schwarzbeck	ISN-CAT6	NTFM81580138	Feb. 15, 2023	1 Year	LEP-E048	<input type="checkbox"/>
CVP	Schwarzbeck	TK9420	01099	Feb. 15, 2023	1 Year	LEP-E078	<input type="checkbox"/>
Current Probe	Rohde & Schwarz	EZ-17	101380	Feb. 15, 2023	1 Year	LEP-E079	<input type="checkbox"/>
DC LISN	Compliance Direction	AN-100	8321003	Feb. 15, 2023	1 Year	LEP-E081	<input type="checkbox"/>
DC LISN	Compliance Direction	AN-100	8321004	Feb. 15, 2023	1 Year	LEP-E082	<input type="checkbox"/>
RF Switching Unit	CD	RSU-M2	8830008	Feb. 15, 2023	1 Year	LEP-E045	<input checked="" type="checkbox"/>
Shielded Room 2	MR	MR-L01	LEP-E050	Nov. 17, 2022	3 Year	LEP-E050	<input checked="" type="checkbox"/>
Test software	EZ-EMC	Fala	EMC-CON 3A1.1+	N/A	N/A	N/A	<input checked="" type="checkbox"/>
For radiated(9K-30M) emission test(966 Chamber 1)							
Equipment	Manufacturer	Model No.	Serial No.	Last Cal.	Cal. Interval	Lab No.	Remark
EMI Test Receiver	Rohde & Schwarz	ESR 3	101849	Feb. 15, 2023	1 Year	LEP-E006	<input type="checkbox"/>
Loop Antenna	Schwarzbeck	FMZB1519B	1519B-036	Feb. 15, 2023	3 Year	LEP-E068	<input type="checkbox"/>
966 Chamber 1	MR	MR-L02	LEP-E051	Nov. 17, 2022	3 Year	LEP-E051	<input type="checkbox"/>
Test software	EZ-EMC	Fala	EMEC-3A1	N/A	N/A	N/A	<input type="checkbox"/>
For radiated(30M-1G) emission test(966 Chamber 1)							
Equipment	Manufacturer	Model No.	Serial No.	Last Cal.	Cal. Interval	Lab No.	Remark
EMI Test Receiver	Rohde & Schwarz	ESR 3	101849	Feb. 15, 2023	1 Year	LEP-E006	<input checked="" type="checkbox"/>
TRILOG Broadband Antenna	Schwarzbeck	VULB 9163	743	Nov. 20, 2022	3 Year	LEP-E005	<input checked="" type="checkbox"/>
Signal Amplifier	HP	8447D	1726A01222	Feb. 15, 2023	1 Year	LEP-E007	<input type="checkbox"/>
6dB Attenuator	RswTech	5W 6dB	LEP-E084	Feb. 15, 2023	1 Year	LEP-E084	<input checked="" type="checkbox"/>
966 Chamber 1	MR	MR-L02	LEP-E051	Nov. 17, 2022	3 Year	LEP-E051	<input checked="" type="checkbox"/>
Test software	EZ-EMC	Fala	EMEC-3A1	N/A	N/A	N/A	<input checked="" type="checkbox"/>
For radiated(Above 1G) emission test(966 Chamber 1)							
Equipment	Manufacturer	Model No.	Serial No.	Last Cal.	Cal. Interval	Lab No.	Remark
Spectrum analyzer	Rohde & Schwarz	FSV40	101412	Feb. 15, 2023	1 Year	LEP-E076	<input checked="" type="checkbox"/>
Spectrum analyzer	Agilent	N9020A	MY49100060	Feb. 15, 2023	1 Year	LEP-E020	<input type="checkbox"/>
Horn antenna	Schwarzbeck	BBHA 9120D	01875	Nov. 20, 2022	3 Year	LEP-E024	<input type="checkbox"/>
Preamplifier	Schwarzbeck	BBN 9718B	00010	Feb. 15, 2023	1 Year	LEP-E025	<input type="checkbox"/>
Horn antenna+Preamplifier	COM-POWER	AH840	10100020	Sep. 05, 2022	3 Year	LEP-E075	<input checked="" type="checkbox"/>
966 Chamber 1	MR	MR-L02	LEP-E051	Nov. 17, 2022	3 Year	LEP-E051	<input checked="" type="checkbox"/>
Test software	EZ-EMC	Fala	EMEC-3A1	N/A	N/A	N/A	<input checked="" type="checkbox"/>
For RF test							
Equipment	Manufacturer	Model No.	Serial No.	Last Cal.	Cal. Interval	Lab No.	Remark
Spectrum analyzer	Rohde & Schwarz	FSV40	101412	Feb. 15, 2023	1 Year	LEP-E076	<input checked="" type="checkbox"/>
Spectrum analyzer	Agilent	N9020A	MY49100060	Feb. 15, 2023	1 Year	LEP-E020	<input checked="" type="checkbox"/>
Vector source	Agilent	N5182A	MY47420382	Feb. 15, 2023	1 Year	LEP-E021	<input checked="" type="checkbox"/>
Analog signal source	Agilent	N5171B	MY51350292	Feb. 15, 2023	1 Year	LEP-E022	<input checked="" type="checkbox"/>
All instrument	Rohde & Schwarz	CMW 500	1201.002K50	Feb. 15, 2023	1 Year	LEP-E019	<input checked="" type="checkbox"/>
High and low temperature chamber	Math-mart	MT-1202-40	LEP-E041	Feb. 15, 2023	1 Year	LEP-E041	<input checked="" type="checkbox"/>
control unit	Tonscend	JS0806-2	10165	Feb. 15, 2023	1 Year	LEP-E034	<input checked="" type="checkbox"/>
Testing software	Tonscend	JSTS1120-3	Ver 2.6.77.0518	N/A	N/A	N/A	<input checked="" type="checkbox"/>

2.3. MEASUREMENT UNCERTAINTY

The following measurement uncertainty levels have been estimated for tests performed on the apparatus:

Parameter	Uncertainty
Radio Frequency	$\pm 1 \times 10^{-5}$
Maximum Peak Output Power Test	$\pm 1.0\%$
Conducted Emissions Test	$\pm 3.08\text{dB}$
Radiated Emission Test	$\pm 4.60\text{dB}$
Power Density	$\pm 0.9\%$
Occupied Bandwidth Test	$\pm 2.3\%$
Band Edge Test	$\pm 1.2\%$
Antenna Port Emission	$\pm 3\text{dB}$
Temperature	$\pm 3.2\%$
Humidity	$\pm 2.5\%$
Measurement Uncertainty for a level of Confidence of 95%	

2.4. TEST FACILITY

EMC Lab. : The Laboratory has been assessed and proved to be in compliance with CNAS/CL01
The Certificate Registration Number is L10100.
The Laboratory has been assessed and proved to be in compliance with A2LA
The Certificate Registration Number is 6901.01
FCC Designation No.: CN1351
Test Firm Registration No.: 397428
ISED CAB identifier: CN0151
Test Firm Registration No.: 20133

Test Location : Dongguan Lepont Testing Service Co., Ltd.

Address : Room 102, Building 11, No.7, Houjie Science And Technology Avenue, Houjie, Dongguan, Guangdong, China

3. SETUP OF EQUIPMENT UNDER TEST

3.1. RADIO FREQUENCY TEST SETUP 1

The Bluetooth V5.1 component's antenna ports(s) of the EUT are connected to the measurement instrument per an appropriate attenuator. The EUT is controlled by PC/software to emit the specified signals for the purpose of measurements.

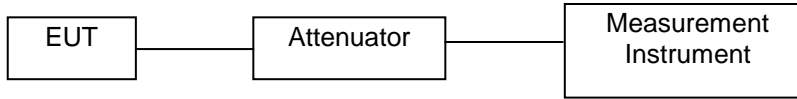

3.2. RADIO FREQUENCY TEST SETUP 2

The test site semi-anechoic chamber has met the requirement of NSA tolerance 4 dB according to the standards: ANSI C63.10. The test distance is 3m. The setup is according to the requirements in Section 13.1.4.1 of ANSI C63.10-2013 and CAN/CSA-CEI/IEC CISPR 32.

Below 30MHz:

The EUT is placed on a turntable 0.8meters above the ground in the chamber, 3 meter away from the antenna (loop antenna). The Antenna should be positioned with its plane vertical at the specified distance from the EUT and rotated about its vertical axis for maximum response at each azimuth about the EUT. The center of the loop shall be 1 m above the ground. For certain applications, the loop antenna plane may also need to be positioned horizontally at the specified distance from the EUT.

Above 30MHz:

The EUT is placed on a turntable 0.8meters above the ground in the chamber, 3 meter away from the antenna. The maximal emission value is acquired by adjusting the antenna height, polarisation and turntable azimuth. Normally, the height range of antenna is 1 m to 4 m, the azimuth range of turntable is 0° to 360°, and the receive antenna has two polarizations Vertical (V) and Horizontal (H).

Above 1GHz:

(Note: the FCC's permission to use 1.5m as an alternative per TCBC Conf call of Dec. 2, 2014.)

The EUT is placed on a turntable 1.5 meters above the ground in the chamber, 3 meter away from the antenna. The maximal emission value is acquired by adjusting the antenna height, polarisation and turntable azimuth. Normally, the height range of antenna is 1 m to 4 m, the azimuth range of turntable is 0° to 360°, and the receive antenna has two polarizations Vertical (V) and Horizontal (H).

(a) Radiated Emission Test Set-Up, Frequency Below 30MHz

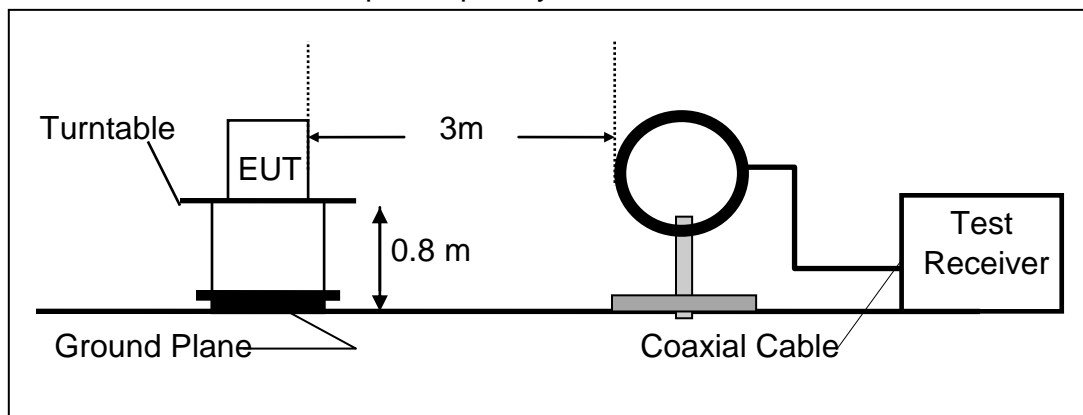

(b) Radiated Emission Test Set-Up, Frequency Below 1000MHz

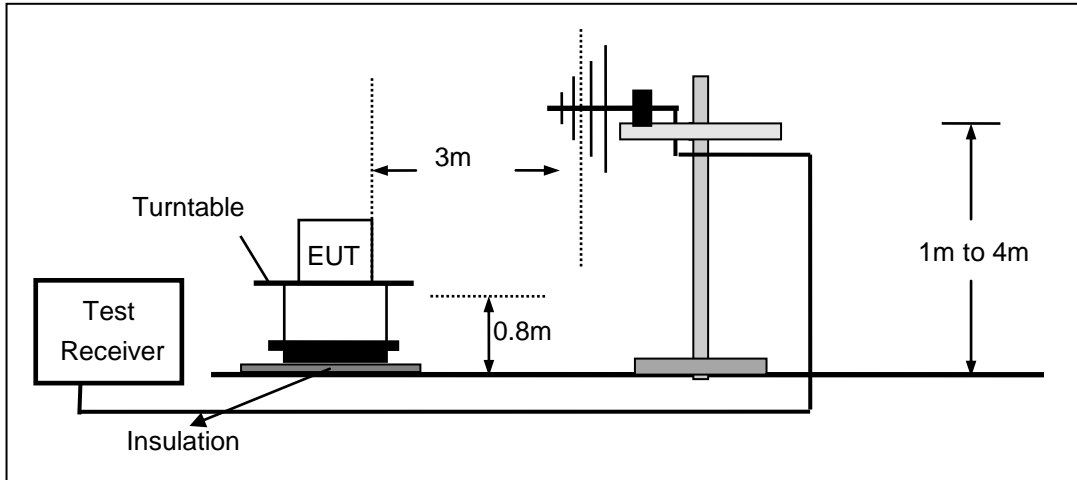

(c) Radiated Emission Test Set-Up, Frequency above 1000MHz

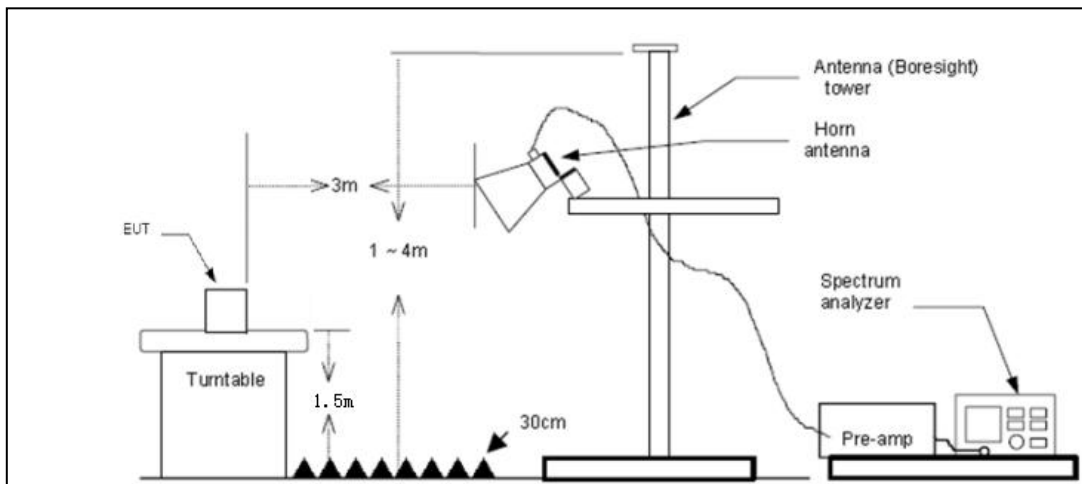

3.3. CONDUCTED EMISSION TEST SETUP

The mains cable of the EUT (Perfect Share Mini) must be connected to LISN. The LISN shall be placed 0.8m from the boundary of EUT and bonded to a ground reference plane for LISN mounted on top of the ground reference plane. This distance is between the closest points of the LISN and the EUT. All other units of the EUT and associated equipment shall be at least 0.8m from the LISN.

Ground connections, where required for safety purposes, shall be connected to the reference ground point of the LISN and, where not otherwise provided or specified by the manufacturer, shall be of same length as the mains cable and run parallel to the mains connection at a separation distance of not more than 0.8m.

According to the requirements in Section 13.1.4.1 of ANSI C63.10-2013 Conducted emissions from the EUT measured in the frequency range between 0.15 MHz and 30 MHz using CISPR Quasi-Peak and average detector mode.

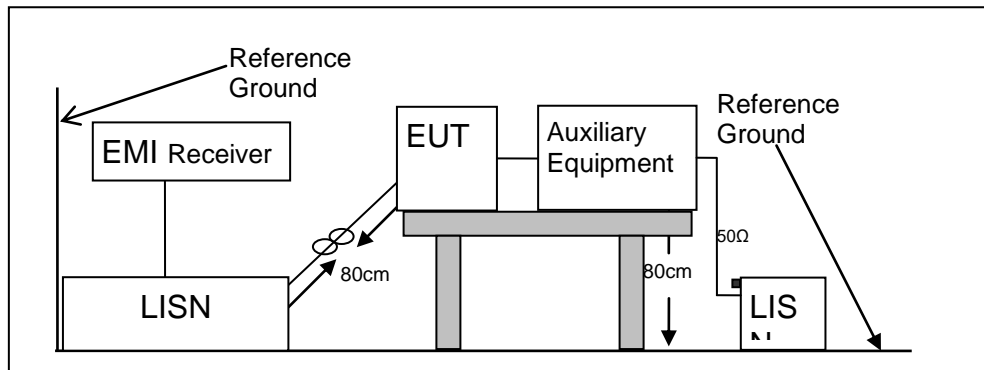

3.4. BLOCK DIAGRAM CONFIGURATION OF TEST SYSTEM

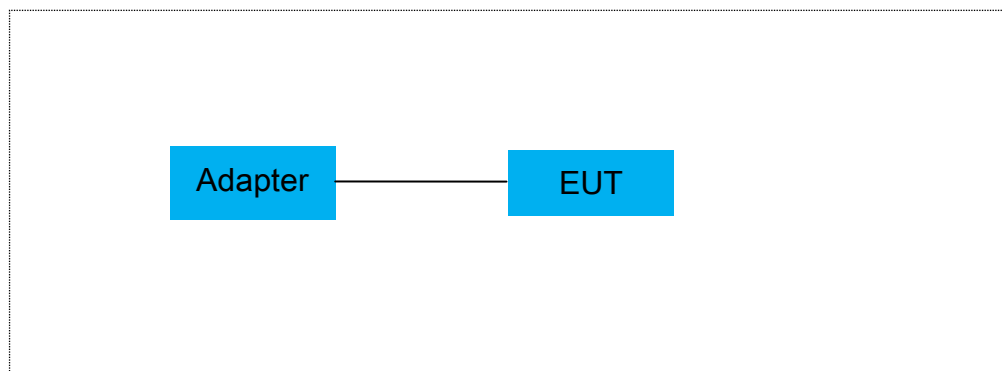

4. TEST RESULTS AND MEASUREMENT DATA

4.1. BANDWIDTH TEST

4.1.1. Applicable Standard

According to FCC Part 15.215

4.1.2. Conformance Limit

No limit requirement.

4.1.3. Test Configuration

Test according to clause 3.1 radio frequency test setup 1

4.1.4. Test Procedure

The EUT was operating in controlled its channel. Printed out the test result from the spectrum by hard copy function.

The RF output of EUT was connected to the spectrum analyzer by RF cable and attenuator. The path loss was compensated to the results for each measurement.

Set to the maximum power setting and enable the EUT transmit continuously

Set RBW \geq 1% of the 20 dB bandwidth(30KHz)

Set the video bandwidth (VBW) \geq RBW(100KHz).

Set Span= approximately 2 to 3 times the 20 dB bandwidth

Set Detector = Peak.

Set Trace mode = max hold.

Set Sweep = auto couple.

Measure the maximum width of the emission that is constrained by the frequencies associated with the two outermost amplitude points (upper and lower frequencies) that are attenuated by 20 dB relative to the maximum level measured in the fundamental emission.

Measure and record the results in the test report.

Test Results:

Modulation Mode	Channel Number	Channel Frequency (MHz)	Measurement Bandwidth (MHz)	Limit(MHz)	Verdict
GFSK	1	2405	2.553	N/A	PASS
GFSK	2	2430	2.597	N/A	PASS
GFSK	3	2470	2.570	N/A	PASS
Note: N/A (Not Applicable)					

Test Model Channel 1: 2405MHz 20dB Bandwidth



Test Model Channel 2: 2430MHz 20dB Bandwidth



Test Model

Channel 3 2470MHz 20dB Bandwidth



4.2. RADIATED SPURIOUS EMISSION

4.2.1. Applicable Standard

According to FCC Part 15.249 and 15.209

4.2.2. Conformance Limit

According to FCC Part 15.249: radiated emissions which fall in the restricted bands, as defined in §15.205(a), must also comply with the radiated emission limits specified in §15.209(a) (see §15.205(c)).

According to FCC Part 15.205, Restricted bands

MHz	MHz	MHz	GHz
0.090-0.110	16.42-16.423	399.9-410	4.5-5.15
10.495-0.505	16.69475-16.69525	608-614	5.35-5.46
2.1735-2.1905	16.80425-16.80475	960-1240	7.25-7.75
4.125-4.128	25.5-25.67	1300-1427	8.025-8.5
4.17725-4.17775	37.5-38.25	1435-1626.5	9.0-9.2
4.20725-4.20775	73-74.6	1645.5-1646.5	9.3-9.5
6.215-6.218	74.8-75.2	1660-1710	10.6-12.7
6.26775-6.26825	123-138	2200-2300	14.47-14.5
8.291-8.294	149.9-150.05	2310-2390	15.35-16.2
8.362-8.366	156.52475-156.52525	2483.5-2500	17.7-21.4
8.37625-8.38675	156.7-156.9	2690-2900	22.01-23.12
8.41425-8.41475	162.0125-167.17	3260-3267	23.6-24.0
12.29-12.293	167.72-173.2	3332-3339	31.2-31.8
12.51975-12.52025	240-285	3345.8-3358	36.43-36.5
12.57675-12.57725	322-335.4	3600-4400	(2)
13.36-13.41			

According to FCC Part 15.205, the level of any transmitter spurious emission in Restricted bands shall not exceed the level of the emission specified in the following table

Restricted Frequency(MHz)	Field Strength (μV/m)	Field Strength (dBμV/m)	Measurement Distance
0.009-0.490	2400/F(KHz)	20 log (uV/m)	300
0.490-1.705	24000/F(KHz)	20 log (uV/m)	30
1.705-30	30	29.5	30
30-88	100	40	3
88-216	150	43.5	3
216-960	200	46	3
Above 960	500	54	3

Remark :1. Emission level in dBuV/m=20 log (uV/m)

2. Measurement was performed at an antenna to the closed point of EUT distance of meters.

3. Distance extrapolation factor =40log(Specific distance/ test distance)(dB);

Limit line=Specific limits(dBuV) + distance extrapolation factor.

for the frequency ranges below 30 MHz, a narrower RBW is used for these ranges but the measured value should add a RBW correction factor (RBWCF) where RBWCF [dB] =10*Ig(100 [kHz]/narrower RBW [kHz]). , the narrower RBW is 1 kHz and RBWCF is 20 dB for the

frequency 9 kHz to 150 kHz, and the narrower RBW is 10 kHz and RBWCF is 10 dB for the frequency 150 kHz to 30 MHz.

Field strength of fundamental and Field strength of harmonics Limit:

Fundamental frequency	Field strength of fundamental (millivolts/meter)	Field strength of harmonics (microvolts/meter)
902-928 MHz	50(94 dBV/m)	500(54 dBV/m)
2400-2483.5 MHz	50(94 dBV/m)	500(54 dBV/m)
5725-5875 MHz	50(94 dBV/m)	500(54 dBV/m)
24.0-24.25 GHz	250(108 dBV/m)	2500(68 dBV/m)

As shown in §15.35(b), for frequencies above 1000 MHz, the field strength limits in paragraphs (a) and (b) of this section are based on average limits. However, the peak field strength of any emission shall not exceed the maximum permitted average limits specified above by more than 20 dB under any condition of modulation

4.2.3. Test Configuration

Test according to clause 6.2 radio frequency test setup 2

4.2.4. Test Procedure

This test is required for any spurious emission that falls in a Restricted Band, as defined in Section 15.205. It must be performed with the highest gain of each type of antenna proposed for use with the EUT. Use the following spectrum analyzer settings:

The EUT was placed on a turn table which is 0.8m above ground plane.

Maximum procedure was performed on the highest emissions to ensure EUT compliance.

Span = wide enough to fully capture the emission being measured

RBW = 1 MHz for $f \geq 1$ GHz(1GHz to 25GHz), 100 kHz for $f < 1$ GHz(30MHz to 1GHz)

VBW \geq RBW

Sweep = auto

Detector function = peak

Trace = max hold

Follow the guidelines in ANSI C63.10-2013 with respect to maximizing the emission by rotating the EUT, measuring the emission while the EUT is situated in three orthogonal planes (if appropriate), adjusting the measurement antenna height and polarization, etc. A pre-amp and a high pass filter are required for this test, in order to provide the measuring system with sufficient sensitivity. Allow the trace to stabilize. The peak reading of the emission, after being corrected by the antenna factor, cable loss, pre-amp gain, etc., is the peak field strength, which must comply with the limit specified in Section 15.35(b). Submit this data.

Now set the VBW to 10 Hz, while maintaining all of the other instrument settings. This peak level, once corrected, must comply with the limit specified in Section 15.209. If the dwell time per channel of the hopping signal is less than 100 ms, then the reading obtained with the 10 Hz VBW may be further adjusted by a "duty cycle correction factor", derived from $20\log(\text{dwell time}/100 \text{ ms})$, in an effort to demonstrate compliance with the 15.209 limit. Submit this data.

Repeat above procedures until all frequency measured was complete.

Test Results:

■ **Field Strength of the fundamental signal**

Frequency	Factor	Meter Reading	Emission Level	Limits	Margin	Detector Type	Ant. Pol.
(MHz)	(dB)	(dBμV)	(dBμV/m)	(dBμV/m)	(dB)		H/V
2405	13.75	75.09	88.84	114	-25.16	peak	V
	13.75	54.74	68.49	94	-25.51	AVG	V
	13.75	74.07	87.82	114	-26.18	peak	H
	13.75	53.24	66.99	94	-27.01	AVG	H
2430	14.01	66.52	80.53	114	-33.47	peak	V
	14.01	48.05	62.06	94	-31.94	AVG	V
	14.01	63.95	77.96	114	-36.04	peak	H
	14.01	44.84	58.85	94	-35.15	AVG	H
2470	14.32	69.45	83.77	114	-30.23	peak	V
	14.32	51.61	65.93	94	-28.07	AVG	V
	14.32	67.41	81.73	114	-32.27	peak	H
	14.32	48.62	62.94	94	-31.06	AVG	H

Note: (1) Correct Factor= Antenna Factor +Cable Loss- Amplifier Gain
(2) Emission Level= Reading Level+Probe Factor +Cable Loss

■ Spurious Emission Above 1GHz (1GHz to 25GHz)

Worse case mode:		2405MHz		Test channel:		Lowest	
Frequency	Meter Reading	Factor	Emission Level	Limits	Over	Detector Type	Ant. Pol.
(MHz)	(dBμV)	(dB)	(dBμV/m)	(dBμV/m)	(dB)		H/V
4810	53.04	-4.33	48.71	74	-25.29	Peak	H
7215	50.58	1.01	51.59	74	-22.41	Peak	H
4810	52.35	-4.33	48.02	74	-25.98	Peak	V
7215	49.47	1.01	50.48	74	-23.52	Peak	V

Worse case mode:		2430MHz		Test channel:		Middle	
Frequency	Meter Reading	Factor	Emission Level	Limits	Over	Detector Type	Ant. Pol.
(MHz)	(dBμV)	(dB)	(dBμV/m)	(dBμV/m)	(dB)		H/V
4860	50.69	-4.11	46.58	74	-27.42	peak	H
7290	48.89	1.51	50.40	74	-23.60	peak	H
4860	51.75	-4.11	47.64	74	-26.36	peak	V
7290	49.94	1.51	51.45	74	-22.55	peak	V

Worse case mode:		2470MHz		Test channel:		Highest	
Frequency	Meter Reading	Factor	Emission Level	Limits	Over	Detector Type	Ant. Pol.
(MHz)	(dBμV)	(dB)	(dBμV/m)	(dBμV/m)	(dB)		H/V
4940	49.80	-4.04	45.76	74	-28.24	Peak	H
7410	49.60	1.57	51.17	74	-22.83	Peak	H
4940	49.16	-4.04	45.12	74	-28.88	Peak	V
7410	48.97	1.57	50.54	74	-23.46	Peak	V

- Note:** (1) All Readings are Peak Value (VBW=3MHz) and Peak Value(VBW=10Hz).
 (2) Emission Level= Reading Level+Correct Factor +Cable Loss.
 (3) Correct Factor= Ant_F + Cab_L - Preamp
 (4) The reading of emissions are attenuated more than 20dB below the permissible limits or the field strength is too small to be measured.

■ Spurious Emission below 1GHz (30MHz to 1GHz)

All modes have been tested, and the worst result recorded was report as below:

Test Mode:	TX 2405MHz	Test Voltage:	DC 3V
Temperature:	24.3°C	Phase:	Vertical
Relative Humidity:	53%	Pressure:	101.4KPa

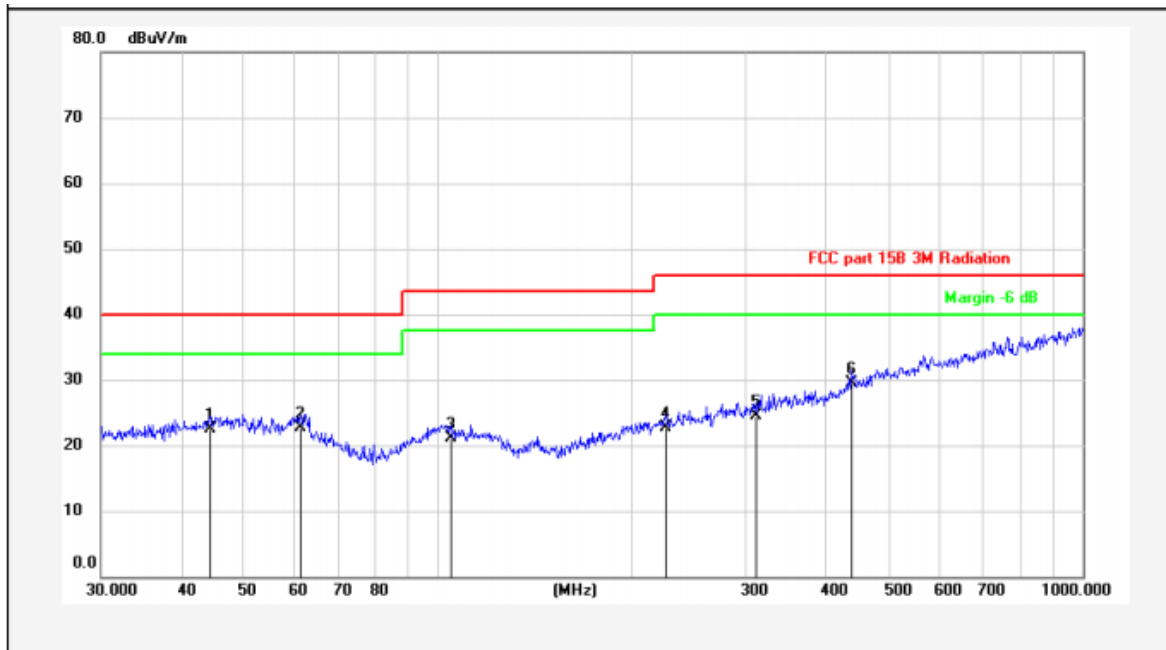

No.	Frequency (MHz)	Reading (dBuV/m)	Antenna (dB/m)	Cable (dB)	Result (dBuV/m)	Limit (dBuV/m)	Margin (dB)	Detector
1	44.2751	7.34	13.81	1.45	22.60	40.00	-17.40	QP
2	61.1315	9.30	11.95	1.45	22.70	40.00	-17.30	QP
3	104.5361	6.56	12.52	2.12	21.20	43.50	-22.30	QP
4	225.3077	7.78	11.98	2.94	22.70	46.00	-23.30	QP
5	311.0867	7.49	13.67	3.44	24.60	46.00	-21.40	QP
6	437.1199	9.35	16.13	4.02	29.50	46.00	-16.50	QP

Test Mode:	TX 2405MHz	Test Voltage:	DC 3V
Temperature:	24.4°C	Phase:	Horizontal
Relative Humidity:	49%	Pressure:	101.5KPa

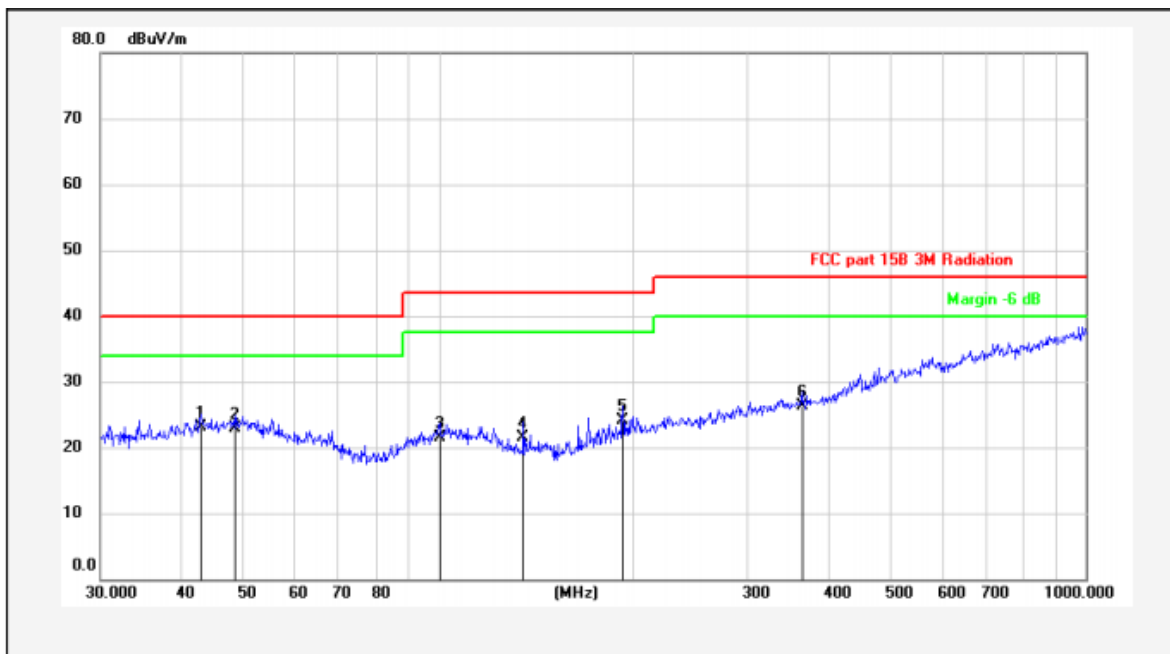

No.	Frequency (MHz)	Reading (dBuV/m)	Antenna (dB/m)	Cable (dB)	Result (dBuV/m)	Limit (dBuV/m)	Margin (dB)	Detector
1	42.8997	7.87	13.81	1.42	23.10	40.00	-16.90	QP
2	48.3318	7.29	14.1	1.51	22.90	40.00	-17.10	QP
3	100.2286	6.84	12.69	2.07	21.60	43.50	-21.90	QP
4	135.0319	10.30	9	2.3	21.60	43.50	-21.90	QP
5	192.4186	10.57	10.89	2.74	24.20	43.50	-19.30	QP
6	364.2595	8.23	14.43	3.74	26.40	46.00	-19.60	QP

4.3. BAND EDGES REQUIREMENT

4.3.1. Applicable Standard

According to FCC Part 15.249(d)

4.3.2. Test Configuration

Test according to clause 3.2 radio frequency test setup 2

4.3.3. Test Procedure

Follow the guidelines in ANSI C63.10: Clause 6.10

Pre-Scan has been conducted to determine the worst-case mode from all possible combinations between available modulations, data rates and antenna ports(if EUT with antenna diversity architecture). The lowest, middle and highest channels were selected for the final test as listed below.

■ BAND EDGES REQUIREMENT DATA

Worse case mode:		GFSK		Test channel:		2405MHz	
Frequency	Meter Reading	Factor	Emission Level	Limits	Over	Detector	Ant. Pol.
(MHz)	(dB μ V)	(dB)	(dB μ V/m)	(dB μ V/m)	(dB)	Type	H/V
2390.000	65.36	-9.2	56.16	74	-17.84	peak	H
2390.000	54.56	-9.2	45.36	54	-8.64	AVG	H
2400.000	69.29	-9.3	49.90	74	-14.10	peak	H
2400.000	56.67	-9.3	47.28	54	-6.72	AVG	H
2390.000	59.03	-9.2	49.83	74	-24.17	peak	V
2390.000	44.66	-9.2	35.46	54	-18.54	AVG	V
2400.000	60.00	-9.3	50.61	74	-23.39	peak	V
2400.000	46.76	-9.3	37.37	54	-16.63	AVG	V

Worse case mode:		GFSK		Test channel:		2470MHz	
Frequency	Meter Reading	Factor	Emission Level	Limits	Over	Detector	Ant. Pol.
(MHz)	(dB μ V)	(dB)	(dB μ V/m)	(dB μ V/m)	(dB)	Type	H/V
2483.500	59.85	-9.2	50.65	74	-23.35	peak	H
2483.500	46.98	-9.2	37.78	54	-16.22	AVG	H
2483.500	60.03	-9.3	50.73	74	-23.27	peak	V
2483.500	51.36	-9.3	42.06	54	-11.94	AVG	V

4.4. ANTENNA APPLICATION

4.4.1. Antenna Requirement

Standard	Requirement
FCC CRF Part 15.203	An intentional radiator shall be designed to ensure that no antenna other than that furnished by the responsible party shall be used with the device. The use of a permanently attached antenna or of an antenna that uses a unique coupling to the intentional radiator shall be considered sufficient to comply with the provisions of this section. The manufacturer may design the unit so that a broken antenna can be replaced by the user, but the use of a standard antenna jack or electrical connector is prohibited. This requirement does not apply to carrier current devices or to devices operated under the provisions of §15.211, §15.213, §15.217, §15.219, or §15.221. Further, this requirement does not apply to intentional radiators that must be professionally installed, such as perimeter protection systems and some field disturbance sensors, or to other intentional radiators which, in accordance with §15.31(d), must be measured at the installation site. However, the installer shall be responsible for ensuring that the proper antenna is employed so that the limits in this part are not exceeded.

For intentional device, according to FCC 47 CFR Section 15.203, an intentional radiator shall be designed to ensure that no antenna other than that furnished by the responsible party shall be used with the device.

4.4.2. Result: PASS.

The EUT has 1 antennas: antenna has a gain of **-1.0** dBi;

- Antenna use a permanently attached antenna which is not replaceable.
- Not using a standard antenna jack or electrical connector for antenna replacement
- The antenna has to be professionally installed (please provide method of installation)

Note: which in accordance to section 15.203, please refer to the internal photos.

----- **END OF REPORT** -----