

Dongguan Shijie Xianghong Inductor Coil Factory	Product Specifications	Code :XH20171030001 Version: 01 Page : 1 / 1
--	-------------------------------	--

Client	shenzhenshijingruikeji youxiangongsi	Material	2RS-N φ0.3	Use machine
Model No.	#REF!	Name	Self adhesive coil	Single axis winding machine

Specification requirements:

Winding direction	Resistance (DCR)	Test Conditions	Inductance value(L)	Turns No.	Dimensions(mm)	
CW	0.29Ω Ref@25℃	1.0KHZ,1V	10uH±10%	25T Ref	A	10±0.2
					B	18±0.5
					C	0.6±0.2
					E	35±5
					F	2~4

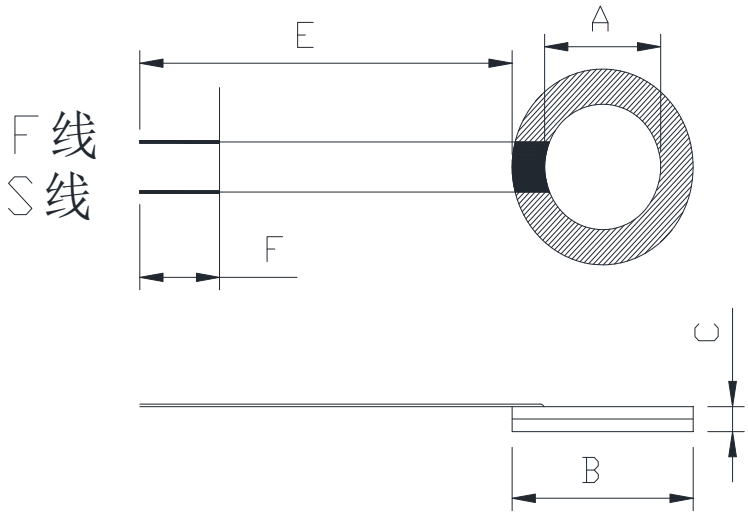

**Remark:1.Attach 5MM to the intersection of leads
Tape 2-3 times.**

Version	Modify content	Modify date	Remarks
01	First issue	2017.10.30	

Approval				
Please confirm and sign back this specification drawing, which will be kept as a customer drawing.	Made	Confirmed	client confirmation	
	Li Ming	Xu xixian		