

FCC RF Test Report

APPLICANT : FCNT LLC.
EQUIPMENT : Mobile cellular phone
BRAND NAME : Raku-Raku smartphone a
MODEL NAME : A401FC
FCC ID : 2BEPUFMP198
STANDARD : 47 CFR Part 2, Part 27 Subpart Q
CLASSIFICATION : PCS Licensed Transmitter Held to Ear (PCE)
TEST DATE(S) : May 01, 2024 ~ Jun. 18, 2024

We, Sporton International Inc. (KunShan), would like to declare that the tested sample has been evaluated in accordance with the procedures given in ANSI C63.26-2015 and shown compliance with the applicable technical standards.

This report contains data that were produced under subcontract by Sporton International Inc. (Shenzhen)

The test results in this report apply exclusively to the tested model / sample. Without written approval of Sporton International Inc. (KunShan), the test report shall not be reproduced except in full.

Jason Jia

Approved by: Jason Jia



Sporton International Inc. (Kunshan)

**No. 1098, Pengxi North Road, Kunshan Economic Development Zone Jiangsu Province 215300
People's Republic of China**



TABLE OF CONTENTS

REVISION HISTORY..... 3
SUMMARY OF TEST RESULT 4
1 GENERAL DESCRIPTION 5
1.1 Applicant 5
1.2 Manufacturer 5
1.3 Product Feature of Equipment Under Test 5
1.4 Product Specification of Equipment Under Test 5
1.5 Modification of EUT 6
1.6 Maximum EIRP Power and Emission Designator 6
1.7 Testing Site 7
1.8 Test Software 7
1.9 Applied Standards 8
2 TEST CONFIGURATION OF EQUIPMENT UNDER TEST 9
2.1 Test Mode 9
2.2 Connection Diagram of Test System 10
2.3 Support Unit used in test configuration and system 10
2.4 Measurement Results Explanation Example 10
2.5 Frequency List of Low/Middle/High Channels 11
3 CONDUCTED TEST ITEMS 12
3.1 Measuring Instruments 12
3.2 Test Setup 12
3.3 Test Result of Conducted Test 12
3.4 Conducted Output Power Measurement 13
3.5 Peak-to-Average Ratio 14
3.6 EIRP 15
3.7 Occupied Bandwidth 16
3.8 Conducted Band Edge Measurement 17
3.9 Conducted Spurious Emission Measurement 18
3.10 Frequency Stability Measurement 19
4 RADIATED TEST ITEMS 20
4.1 Measuring Instruments 20
4.2 Test Setup 20
4.3 Test Result of Radiated Test 21
4.4 Radiated Spurious Emission Measurement 22
5 LIST OF MEASURING EQUIPMENT 23
6 MEASUREMENT UNCERTAINTY 24
APPENDIX A. TEST RESULTS OF CONDUCTED TEST
APPENDIX B. TEST RESULTS OF RADIATED TEST
APPENDIX C. TEST SETUP PHOTOGRAPHS



SUMMARY OF TEST RESULT

Report Section	FCC Rule	Description	Limit	Result	Remark
3.4	§2.1046	Conducted Output Power	—	Report Only	-
3.5	§27.50 (k)(4)	Peak-to-Average Ratio	<13dB	PASS	
3.6	§27.50 (k)(3)	EIRP	EIRP < 1W (30dBm)	PASS	-
3.7	§2.1049	Occupied Bandwidth	—	Report Only	-
3.8	§2.1051 §27.53 (n)(2)	Conducted Band Edge Measurement	-13dBm/MHz	PASS	-
3.9	§2.1051 §27.53 (n)(2)	Conducted Spurious Emission	-13dBm/MHz	PASS	-
3.10	§2.1055 §27.54	Frequency Stability Temperature & Voltage	Within the band	PASS	-
4.4	§2.1053 §27.53 (n)(2)	Radiated Spurious Emission	-13dBm/MHz	PASS	Under limit 30.68 dB at 10354.00 MHz

Conformity Assessment Condition:

- The test results (PASS/FAIL) with all measurement uncertainty excluded are presented against the regulation limits or in accordance with the requirements stipulated by the applicant/manufacturer who shall bear all the risks of non-compliance that may potentially occur if measurement uncertainty is taken into account.
- The measurement uncertainty please refer to each test result in the section "Measurement Uncertainty"

Disclaimer:

The product specifications of the EUT presented in the test report that may affect the test assessments are declared by the manufacturer who shall take full responsibility for the authenticity.

1 General Description

1.1 Applicant

FCNT LLC.

Sanki Yamato Bldg. 3F, 7-10-1, Chuorinkan, Yamato-shi, Kanagawa, 242-0007, Japan

1.2 Manufacturer

FCNT LLC.

Sanki Yamato Bldg. 3F, 7-10-1, Chuorinkan, Yamato-shi, Kanagawa, 242-0007, Japan

1.3 Product Feature of Equipment Under Test

Product Feature	
Equipment	Mobile cellular phone
Brand Name	Raku-Raku smartphone a
Model Name	A401FC
FCC ID	2BEPUFMP198
IMEI Code	Conducted : 354401310043544/354401310043554 Radiation : 354401310039765/354401310039773
HW Version	V4
SW Version	FAC V006
EUT Stage	Identical Prototype

1.4 Product Specification of Equipment Under Test

Product Feature	
Tx/Rx Frequency	5G NR n77: 3450 MHz ~ 3550 MHz 5G NR n78: 3450 MHz ~ 3550 MHz
SCS	30kHz
Bandwidth	n77 : 20 / 40 / 100MHz n78 : 20 / 40 / 80 / 100MHz
Antenna Gain	5G NR n77: -1.8 dBi 5G NR n78: -1.8 dBi
Type of Modulation	CP-OFDM: QPSK / 16QAM / 64QAM / 256QAM DFT-s-OFDM: PI/2 BPSK / QPSK / 16QAM / 64QAM / 256QAM

Remark:

1. 5G NR n77/n78 support SA & NSA mode. According to the maximum power between SA and NSA mode, SA covers NSA mode, and n78 additional test NSA for 80M BW.
2. All the supported EN-DC combinations are verified conducted power, only the EN-DC combination with highest power are shown in the report.
3. The EN-DC mode combination could be referred to the product spec.

1.5 Modification of EUT

No modifications are made to the EUT during all test items.

1.6 Maximum EIRP Power and Emission Designator

5G NR n77 SA		PI/2 BPSK / QPSK		16QAM/64QAM/256QAM	
BW (MHz)	Frequency Range (MHz)	Maximum EIRP(W)	Emission Designator (99%OBW)	Maximum EIRP(W)	Emission Designator (99%OBW)
20	3460.02 ~ 3540.00	0.0106	18M2G7D	0.0107	18M2W7D
40	3470.01 ~ 3529.98	0.0098	37M8G7D	0.0098	37M8W7D
100	3500.01	0.0106	97M0G7D	0.0107	97M3W7D
5G NR n78 SA		PI/2 BPSK / QPSK		16QAM/64QAM/256QAM	
BW (MHz)	Frequency Range (MHz)	Maximum EIRP(W)	Emission Designator (99%OBW)	Maximum EIRP(W)	Emission Designator (99%OBW)
20	3460.02 ~ 3540.00	0.0106	18M2G7D	0.0107	18M2W7D
40	3470.01 ~ 3529.98	0.0098	37M8G7D	0.0098	37M8W7D
80	3490.02 ~ 3510.00	0.0106	77M4G7D	0.0106	77M5W7D
100	3500.01	0.0106	97M0G7D	0.0107	97M3W7D

Note:

1. 5G NR Band n77 overlaps the entire frequency range of Band n78, and n77 power > n78 power, therefore the conducted test results of n77 provided in this report cover n78 except 80MHz Bandwidth.
2. All modulations have been tested, and only the worst test results of PSK & QAM are shown in the report.

1.7 Testing Site

Sporton International Inc. (Kunshan) is accredited to ISO/IEC 17025:2017 by American Association for Laboratory Accreditation with Certificate Number 5145.02.

Test Firm	Sporton International Inc. (Kunshan)		
Test Site Location	No. 1098, Pengxi North Road, Kunshan Economic Development Zone Jiangsu Province 215300 People's Republic of China TEL : +86-512-57900158		
Test Site No.	Sporton Site No.	FCC Designation No.	FCC Test Firm Registration No.
	TH01-KS	CN1257	314309

Sporton International Inc. (ShenZhen) is accredited to ISO/IEC 17025:2017 by American Association for Laboratory Accreditation with Certificate Number 5145.01.

Test Firm	Sporton International Inc. (ShenZhen)		
Test Site Location	101, 1st Floor, Block B, Building 1, No. 2, Tengfeng 4th Road, Fenghuang Community, Fuyong Street, Baoan District, Shenzhen City, Guangdong Province 518103 People's Republic of China TEL: +86-755-86066985		
Test Site No.	Sporton Site No.	FCC Designation No.	FCC Test Firm Registration No.
	03CH03-SZ	CN1256	421272

1.8 Test Software

Item	Site	Manufacture	Name	Version
1.	TH01-KS	Tonscend	JS1120-3 test system China_210602	3.3.10
2.	03CH03-SZ	AUDIX	E3	6.2009-8-24



1.9 Applied Standards

According to the specifications of the manufacturer, the EUT must comply with the requirements of the following standards:

- ♦ 47 CFR Part 2, Part 27 Subpart Q
- ♦ ANSI C63.26-2015
- ♦ FCC KDB 971168 Power Meas License Digital Systems D01 v03r01
- ♦ FCC KDB 412172 D01 Determining ERP and EIRP v01r01

Remark:

1. All test items were verified and recorded according to the standards and without any deviation during the test.
2. This EUT has also been tested and complied with the requirements of FCC Part 15, Subpart B, recorded in a separate test report.

2 Test Configuration of Equipment Under Test

2.1 Test Mode

Antenna port conducted and radiated test items listed below are performed according to KDB 971168 D01 Power Meas. License Digital Systems v03r01 with maximum output power.

Radiated measurements are performed by rotating the EUT in three different orthogonal test planes to find the maximum emission. (Z Plane)

Test Cases	Band	Bandwidth (MHz)	Modulation	RB #	Test Channel
		eg. 5M, 10M, 15M, 20M	eg. PI/2 BPSK, QPSK, 16QAM, 64QAM, 256QAM	1RB, Partial RB, Full RB	L/M/H
Max. Output Power	5G n77	20M, 40M, 100M	All Modulations	1RB, Full RB	L, M, H
	5G n78	20M, 40M, 80M, 100M	All Modulations	1RB, Full RB	L, M, H
Peak-to-Average Ratio	5G n77	20M	PI/2 BPSK, QPSK	1RB, Full RB	M
	5G n78	80M	PI/2 BPSK, QPSK	1RB, Full RB	M
E.I.R.P	5G n77	20M, 40M, 100M	All Modulations	1RB, Full RB	L, M, H
	5G n78	20M, 40M, 80M, 100M	All Modulations	1RB, Full RB	L, M, H
26dB and 99% Bandwidth	5G n77	20M, 40M, 100M	QPSK, 16QAM, 64QAM, 256QAM	Full RB	M
	5G n78	80M	QPSK, 16QAM, 64QAM, 256QAM	Full RB	M
Conducted Band Edge	5G n77	20M, 40M, 100M	PI/2 BPSK, QPSK	1RB, Full RB	L, H
	5G n78	80M	PI/2 BPSK, QPSK	1RB, Full RB	L, H
Conducted Spurious Emission	5G n77	20M, 40M, 100M	PI/2 BPSK, QPSK	1RB	L, M, H
	5G n78	80M	PI/2 BPSK, QPSK	1RB	L, M, H
Frequency Stability	5G n77	20M	PI/2 BPSK	Full RB	M
	5G n78	80M	PI/2 BPSK	Full RB	M
Radiated Spurious Emission	5G n77	Worst case from maximum power			M
	5G n78	Worst case from maximum power			M

Note:

- The device is investigated from 30MHz to 10 times of fundamental signal for radiated spurious emission test under different RB size/offset and modulations in exploratory test. Subsequently, only the worst case emissions are reported.
- Frequency Stability: Normal Voltage = 3.91V ; Low Voltage =3.4V.; High Voltage =4.48V.

2.2 Connection Diagram of Test System

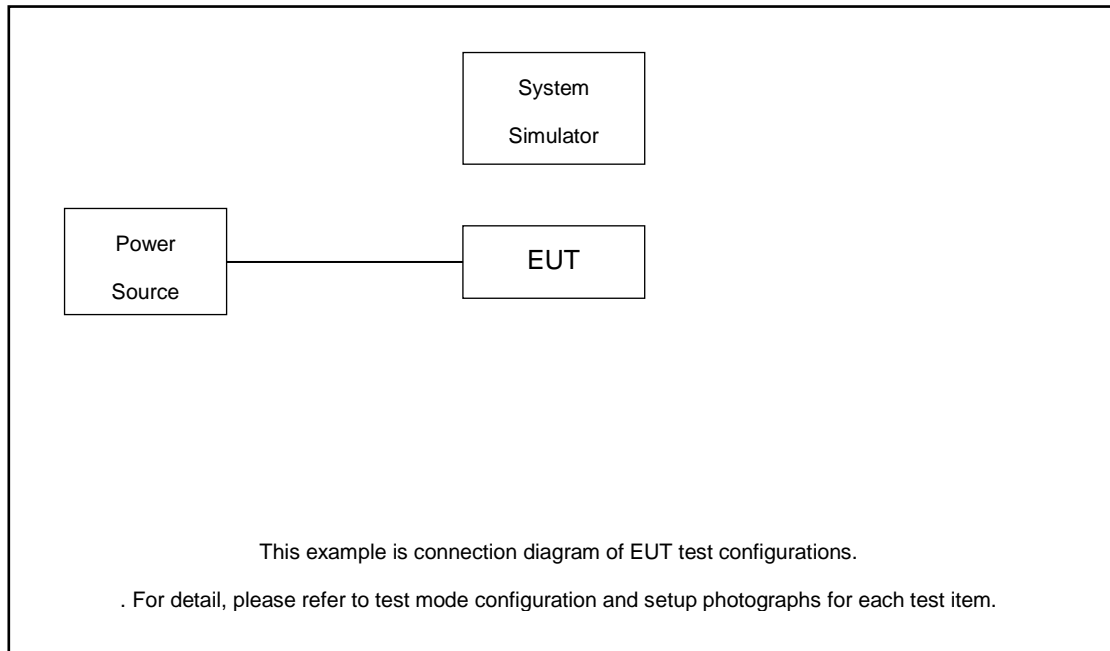

2.3 Support Unit used in test configuration and system

Item	Equipment	Trade Name	Model No.	FCC ID	Data Cable	Power Cord
1.	Power Supply	GWINSTEK	PSS-2002	N/A	N/A	Unshielded, 1.8 m
2.	LTE Base Station	Anritsu	MT8820C	N/A	N/A	Unshielded, 1.8 m
3.	NR Base Station	Anritsu	MT8000A	N/A	N/A	Unshielded, 1.8 m
4.	Adapter	Lenovo	N/A	N/A	N/A	N/A

2.4 Measurement Results Explanation Example

For all conducted test items:

The offset level is set in the spectrum analyzer to compensate the RF cable loss and attenuator factor between EUT conducted output port and spectrum analyzer. With the offset compensation, the spectrum analyzer reading level is exactly the EUT RF output level.

The spectrum analyzer offset is derived from RF cable loss and attenuator factor.

$$\text{Offset} = \text{RF cable loss} + \text{attenuator factor}.$$

Following shows an offset computation example with cable loss 7.0 dB and 10dB attenuator.

Example :

$$\begin{aligned} \text{Offset(dB)} &= \text{RF cable loss(dB)} + \text{attenuator factor(dB)}. \\ &= 7.0 + 10 = 17.0 \text{ (dB)} \end{aligned}$$

2.5 Frequency List of Low/Middle/High Channels

5G n77 Channel and Frequency List				
BW [MHz]	Channel/Frequency(MHz)	Lowest	Middle	Highest
100	Channel	-	633334	-
	Frequency	-	3500.01	-
40	Channel	631334	633334	635332
	Frequency	3470.01	3500.01	3529.98
20	Channel	630668	633334	636000
	Frequency	3460.02	3500.01	3540

5G n78 Channel and Frequency List				
BW [MHz]	Channel/Frequency(MHz)	Lowest	Middle	Highest
100	Channel	-	633334	-
	Frequency	-	3500.01	-
80	Channel	632668	633334	634000
	Frequency	3490.02	3500.01	3510
40	Channel	631334	633334	635332
	Frequency	3470.01	3500.01	3529.98
20	Channel	630668	633334	636000
	Frequency	3460.02	3500.01	3540

3 Conducted Test Items

3.1 Measuring Instruments

See list of measuring instruments of this test report.

3.2 Test Setup

3.2.1 Conducted Output Power

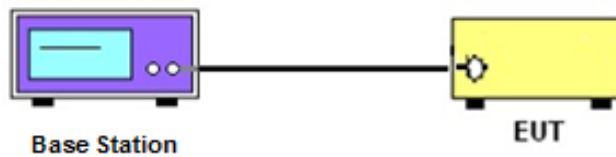

3.2.2 Peak-to-Average Ratio, Occupied / 26dB Bandwidth, Band-Edge and Conducted Spurious Emission

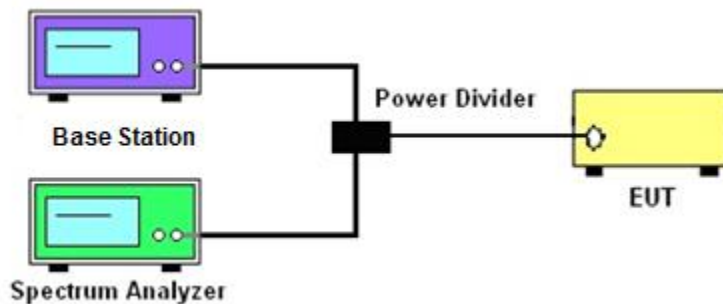

3.2.3 Frequency Stability

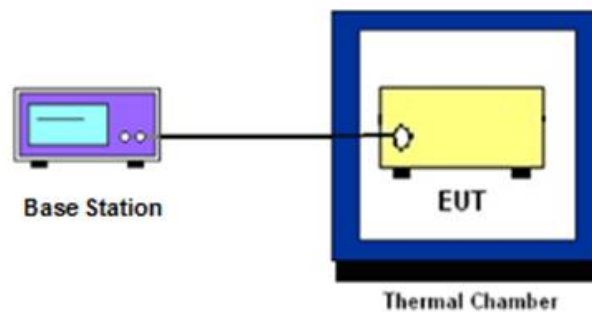

3.3 Test Result of Conducted Test

Please refer to Appendix A.

3.4 Conducted Output Power Measurement

3.4.1 Description of the Conducted Output Power Measurement

A base station simulator was used to establish communication with the EUT. Its parameters were set to transmit the maximum power on the EUT. The measured power in the radio frequency on the transmitter output terminals shall be reported.

3.4.2 Test Procedures

1. The testing follows ANSI C63.26 Section 5.2
2. The transmitter output port was connected to the system simulator.
3. Set EUT at maximum power through the system simulator.
4. Select lowest, middle, and highest channels for each band and different modulation.
5. Measure and record the power level from the system simulator.



3.5 Peak-to-Average Ratio

3.5.1 Description of the PAR Measurement

Power Complementary Cumulative Distribution Function (CCDF) curves provide a means for characterizing the power peaks of a digitally modulated signal on a statistical basis. A CCDF curve depicts the probability of the peak signal amplitude exceeding the average power level. Most contemporary measurement instrumentation include the capability to produce CCDF curves for an input signal provided that the instrument's resolution bandwidth can be set wide enough to accommodate the entire input signal bandwidth. In measuring transmissions in this band using an average power technique, the peak-to-average ratio (PAR) of the transmission may not exceed 13 dB.

3.5.2 Test Procedures

1. The testing follows ANSI C63.26 Section 5.2.3.4 (CCDF).
2. The EUT was connected to spectrum and system simulator via a power divider.
3. Set the CCDF (Complementary Cumulative Distribution Function) option in spectrum analyzer.
4. The highest RF powers were measured and recorded the maximum PAPR level associated with a probability of 0.1 %.
5. Record the deviation as Peak to Average Ratio.



3.6 EIRP

3.6.1 Description of EIRP Limit

§ 27.50 (k)(3)

Mobile devices are limited to 1Watt (30 dBm) EIRP. Mobile devices operating in these bands must employ a means for limiting power to the minimum necessary for successful communications

3.6.2 Test Procedures

1. According to KDB 412172 D01 Power Approach,
2. $EIRP = P_T + G_T - L_C$, $ERP = EIRP - 2.15$, where
 P_T = transmitter output power in dBm
 G_T = gain of the transmitting antenna in dBi
 L_C = signal attenuation in the connecting cable between the transmitter and antenna in dB

3.7 Occupied Bandwidth

3.7.1 Description of Occupied Bandwidth Measurement

The occupied bandwidth is the width of a frequency band such that, below the lower and above the upper frequency limits, the mean powers emitted are each equal to a specified percentage 0.5% of the total mean transmitted power.

The 26 dB emission bandwidth is defined as the frequency range between two points, one above and one below the carrier frequency, at which the spectral density of the emission is attenuated 26 dB below the maximum in-band spectral density of the modulated signal. Spectral density (power per unit bandwidth) is to be measured with a detector of resolution bandwidth equal to approximately 1.0% of the emission bandwidth.

3.7.2 Test Procedures

1. The testing follows ANSI C63.26 Section 5.4
2. The EUT was connected to spectrum analyzer and system simulator via a power divider.
3. The spectrum analyzer center frequency is set to the nominal EUT channel center frequency. The span range for the spectrum analyzer shall be between two and five times the anticipated OBW.
4. The nominal resolution bandwidth (RBW) shall be in the range of 1 to 5 % of the anticipated OBW, and the VBW shall be at least 3 times the RBW.
5. Set the detection mode to peak, and the trace mode to max hold.
6. Determine the reference value: Set the EUT to transmit a modulated signal. Allow the trace to stabilize. Set the spectrum analyzer marker to the highest level of the displayed trace.
(this is the reference value)
7. Determine the “-26 dB down amplitude” as equal to (Reference Value – X).
8. Place two markers, one at the lowest and the other at the highest frequency of the envelope of the spectral display such that each marker is at or slightly below the “-X dB down amplitude” determined in step 6. If a marker is below this “-X dB down amplitude” value it shall be placed as close as possible to this value. The OBW is the positive frequency difference between the two markers.
9. Use the 99 % power bandwidth function of the spectrum analyzer and report the measured bandwidth.

3.8 Conducted Band Edge Measurement

3.8.1 Description of Conducted Band Edge Measurement

§ 27.53 (n)(2)

For mobile operations in the 3450-3550 MHz band, the conducted power of any emission outside the licensee's authorized bandwidth shall not exceed -13 dBm/MHz.

Compliance with this paragraph is based on the use of measurement instrumentation employing a resolution bandwidth of 1 megahertz or greater. However, in the 1 megahertz bands immediately outside and adjacent to the licensee's frequency block, a resolution bandwidth of at least one percent of the emission bandwidth of the fundamental emission of the transmitter may be employed, but limited to a maximum of 200 kHz. In the bands between 1 and 5 MHz removed from the licensee's frequency block, the minimum resolution bandwidth for the measurement shall be 500 kHz.

3.8.2 Test Procedures

1. The testing follows ANSI C63.26 section 5.7
2. The EUT was connected to spectrum analyzer and system simulator via a power divider.
3. The band edges of low and high channels for the highest RF powers were measured.
4. Set RBW $\geq 1\%$ EBW but limited to a maximum of 200 kHz in the 1MHz band immediately outside and adjacent to the band edge.
5. Beyond the 1 MHz and 5 MHz removed from the band edge, set RBW ≥ 500 KHz.
6. Beyond the 5 MHz removed from the band edge, set RBW = 1MHz.
7. Set spectrum analyzer with RMS detector.
8. The RF fundamental frequency should be excluded against the limit line in the operating frequency band.
9. Checked that all the results comply with the emission limit line.

3.9 Conducted Spurious Emission Measurement

3.9.1 Description of Conducted Spurious Emission Measurement

The power of any emission outside of the authorized operating frequency ranges shall not exceed -13 dBm/MHz.

It is measured by means of a calibrated spectrum analyzer and scanned from 9 kHz up to a frequency including its 10th harmonic.

3.9.2 Test Procedures

1. The testing follows ANSI C63.26 section 5.7
2. The EUT was connected to spectrum analyzer and system simulator via a power divider.
3. The RF output of EUT was connected to the spectrum analyzer by RF cable and attenuator. The path loss was compensated to the results for each measurement.
4. The middle channel for the highest RF power within the transmitting frequency was measured.
5. The conducted spurious emission for the whole frequency range was taken.
6. Make the measurement with the spectrum analyzer's RBW = 1MHz, VBW = 3MHz.
7. Set spectrum analyzer with RMS detector.
8. Taking the record of maximum spurious emission.
9. The RF fundamental frequency should be excluded against the limit line in the operating frequency band.
10. Checked that all the results comply with the emission limit line.

3.10 Frequency Stability Measurement

3.10.1 Description of Frequency Stability Measurement

The frequency stability shall be measured by variation of ambient temperature and variation of primary supply voltage to ensure that the fundamental emission stays within the authorized frequency block.

3.10.2 Test Procedures for Temperature Variation

1. The testing follows ANSI C63.26 section 5.6.4
2. The EUT was set up in the thermal chamber and connected with the system simulator.
3. With power OFF, the temperature was decreased to -30°C and the EUT was stabilized before testing. Power was applied and the maximum change in frequency was recorded within one minute.
4. With power OFF, the temperature was raised in 10°C step up to 50°C . The EUT was stabilized at each step for at least half an hour. Power was applied and the maximum frequency change was recorded within one minute.

3.10.3 Test Procedures for Voltage Variation

1. The testing follows ANSI C63.26 section 5.6.5.
2. The EUT was placed in a temperature chamber at $20\pm 5^{\circ}\text{C}$ and connected with the system simulator.
3. The power supply voltage to the EUT was varied from 85% to 115% of the nominal value for other than hand carried battery equipment.
4. For hand carried, battery powered equipment, reduce the primary ac or dc supply voltage to the battery operating end point, which shall be specified by the manufacturer.
5. The variation in frequency was measured for the worst case.

4 Radiated Test Items

4.1 Measuring Instruments

See list of measuring instruments of this test report.

4.2 Test Setup

4.2.1 For radiated test below 30MHz



4.2.2 For radiated test from 30MHz to 1GHz

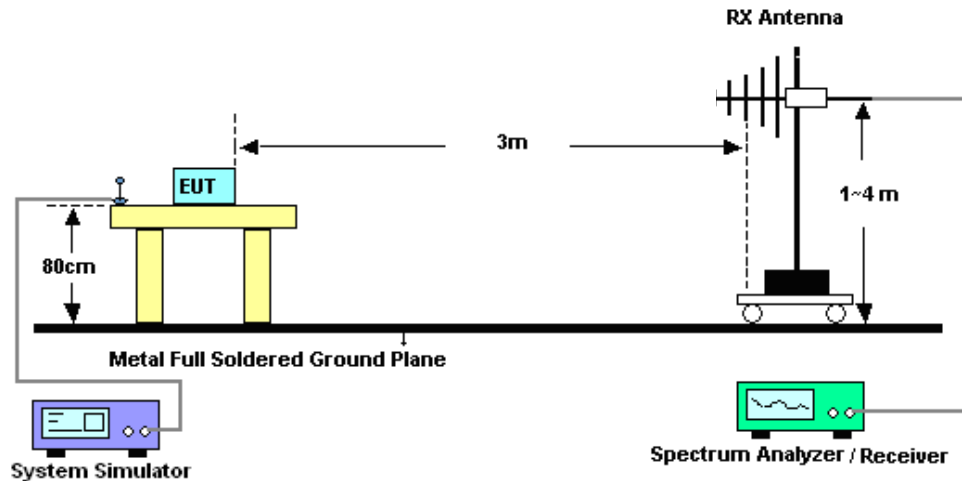

4.2.3 For radiated test above 1GHz



4.3 Test Result of Radiated Test

The low frequency, which started from 9 kHz to 30MHz, was pre-scanned and the result which was 20dB lower than the limit line was not reported.

Please refer to Appendix B.

4.4 Radiated Spurious Emission Measurement

4.4.1 Description of Radiated Spurious Emission

The radiated spurious emission was measured by substitution method according to ANSI/TIA-603-E. The power of any emission outside of the authorized operating frequency ranges shall not exceed -13 dBm/MHz.

The spectrum is scanned from 30 MHz up to a frequency including its 10th harmonic.

4.4.2 Test Procedures

1. The testing follows ANSI C63.26 Section 5.5
2. The EUT was placed on a turntable with 0.8 meter height for frequency below 1GHz and 1.5 meter height for frequency above 1GHz respectively above ground.
3. The EUT was set 3 meters from the receiving antenna mounted on the antenna tower.
4. The table was rotated 360 degrees to determine the position of the highest spurious emission.
5. The height of the receiving antenna is varied between 1m to 4m to search the maximum spurious emission for both horizontal and vertical polarizations.
6. During the measurement, the system simulator parameters were set to force the EUT transmitting at maximum output power.
7. Make the measurement with the spectrum analyzer's RBW = 1MHz, VBW = 3MHz, taking the record of maximum spurious emission.
8. A horn antenna was substituted in place of the EUT and was driven by a signal generator.
9. Tune the output power of signal generator to the same emission level with EUT maximum spurious emission.
$$\text{EIRP (dBm)} = \text{S.G. Power} - \text{Tx Cable Loss} + \text{Tx Antenna Gain}$$
$$\text{ERP (dBm)} = \text{EIRP} - 2.15$$
10. The RF fundamental frequency should be excluded against the limit line in the operating frequency band.



5 List of Measuring Equipment

Instrument	Manufacturer	Model No.	Serial No.	Characteristics	Calibration Date	Test Date	Due Date	Remark
Spectrum Analyzer	R&S	FSV40	101040	10Hz~40GHz	Oct. 11, 2023	May 01, 2024~ Jun. 18, 2024	Oct. 10, 2024	Conducted (TH01-KS)
Power divider	STI	STI08-0055	-	0.5~40GHz	NCR	May 01, 2024~ Jun. 18, 2024	NCR	Conducted (TH01-KS)
Temperature & humidity chamber	Hongzhan	LP-150U	H2014011440	-40~+150°C 20%~95%RH	Jul. 06, 2023	May 01, 2024~ Jun. 18, 2024	Jul. 05, 2024	Conducted (TH01-KS)
EMI Test Receiver&SA	KEYSIGHT	N9038A	MY54450083	20Hz~8.4GHz	Apr. 09, 2024	Jun. 01, 2024~ Jun. 03, 2024	Apr. 08, 2025	Radiation (03CH03-SZ)
EXA Spectrum Analyzer	KEYSIGHT	N9010A	MY55150246	10Hz~44GHz;	Apr. 09, 2024	Jun. 01, 2024~ Jun. 03, 2024	Apr. 08, 2025	Radiation (03CH03-SZ)
Loop Antenna	R&S	HFH2-Z2	100354	9kHz~30MHz	Jun. 28, 2022	Jun. 01, 2024~ Jun. 03, 2024	Jun. 27, 2024	Radiation (03CH03-SZ)
Bilog Antenna	TeseQ	CBL6112D	35408	30MHz~2GHz	Aug. 20, 2023	Jun. 01, 2024~ Jun. 03, 2024	Aug. 19, 2025	Radiation (03CH03-SZ)
Double Ridge Horn Antenna	SCHWARZBECK	BBHA9120D	9120D-1355	1GHz~18GHz	Apr. 09, 2024	Jun. 01, 2024~ Jun. 03, 2024	Apr. 08, 2025	Radiation (03CH03-SZ)
SHF-EHF Horn	com-power	AH-840	101071	18Ghz~40GHz	Apr. 09, 2024	Jun. 01, 2024~ Jun. 03, 2024	Apr. 08, 2025	Radiation (03CH03-SZ)
Amplifier	Burgeon	BPA-530	102211	0.01Hz ~3000MHz	Oct. 18, 2023	Jun. 01, 2024~ Jun. 03, 2024	Oct. 17, 2024	Radiation (03CH03-SZ)
HF Amplifier	MITEQ	TTA1840-35-HG	1871923	18GHz~40GHz	Jul. 07, 2023	Jun. 01, 2024~ Jun. 03, 2024	Jul.06, 2024	Radiation (03CH03-SZ)
Amplifier	Agilent Technologies	83017A	MY39501302	500MHz~26.5GHz	Dec. 27, 2023	Jun. 01, 2024~ Jun. 03, 2024	Dec. 26, 2024	Radiation (03CH03-SZ)
AC Power Source	Chroma	61601	616010002729	N/A	Oct. 18, 2023	Jun. 01, 2024~ Jun. 03, 2024	Oct. 17, 2024	Radiation (03CH03-SZ)
Turn Table	EM	EM1000	N/A	0~360 degree	NCR	Jun. 01, 2024~ Jun. 03, 2024	NCR	Radiation (03CH03-SZ)
Antenna Mast	EM	EM1000	N/A	1 m~4 m	NCR	Jun. 01, 2024~ Jun. 03, 2024	NCR	Radiation (03CH03-SZ)

NCR: No Calibration Required



6 Measurement Uncertainty

The measurement uncertainties shown below were calculated in accordance with the requirements of ANSI 63.26-2015. All the measurement uncertainty value were shown with a coverage K=2 to indicate 95% level of confidence. The measurement data show herein meets or exceeds the CISPR measurement uncertainty values specified in CISPR 16-4-2 and can be compared directly to specified limit to determine compliance.

Uncertainty of Conducted Measurement

Conducted Spurious Emission & Bandedge	±2.26 dB
Occupied Channel Bandwidth	±0.1%
Conducted Power	±0.46 dB
Peak to Average Ratio	±0.46 dB
Frequency Stability	±0.4 Hz

Uncertainty of Radiated Emission Measurement (30 MHz ~ 1000 MHz)

Measuring Uncertainty for a Level of Confidence of 95% (U = 2Uc(y))	3.0 dB
---------------------------------------------------------------------	--------

Uncertainty of Radiated Emission Measurement (1 GHz ~ 18 GHz)

Measuring Uncertainty for a Level of Confidence of 95% (U = 2Uc(y))	3.6 dB
---------------------------------------------------------------------	--------

Uncertainty of Radiated Emission Measurement (1 GHz ~ 40 GHz)

Measuring Uncertainty for a Level of Confidence of 95% (U = 2Uc(y))	3.8 dB
---------------------------------------------------------------------	--------

----- THE END -----



Appendix A. Test Results of Conducted Test

Test Engineer :	Jung Kuo	Temperature :	22~23°C
		Relative Humidity :	40~42%

FR1 N77

Transmitter Conducted Output Power And EIRP, (G_T - L_C)=-1.8dB

NR Band	SCS	BandWidth	Arfcn	Freq(MHz)	Modulation	RB	Conducted Power(dBm)	EIRP (dBm)	EIRP(W)
77	30	100	633334	3500.01	DFT-s-OFDM PI/2 BPSK	135@67	12.04	10.24	0.0106
77	30	100	633334	3500.01	DFT-s-OFDM PI/2 BPSK	1@1	11.47	9.67	0.0093
77	30	100	633334	3500.01	DFT-s-OFDM PI/2 BPSK	1@271	11.18	9.38	0.0087
77	30	100	633334	3500.01	DFT-s-OFDM QPSK	135@67	12.07	10.27	0.0106
77	30	100	633334	3500.01	DFT-s-OFDM QPSK	1@1	11.47	9.67	0.0093
77	30	100	633334	3500.01	DFT-s-OFDM QPSK	1@271	11.19	9.39	0.0087
77	30	100	633334	3500.01	DFT-s-OFDM 16 QAM	135@67	12.11	10.31	0.0107
77	30	100	633334	3500.01	DFT-s-OFDM 16 QAM	1@1	11.5	9.7	0.0093
77	30	100	633334	3500.01	DFT-s-OFDM 16 QAM	1@271	11.23	9.43	0.0088
77	30	100	633334	3500.01	DFT-s-OFDM 64 QAM	135@67	12.07	10.27	0.0106
77	30	100	633334	3500.01	DFT-s-OFDM 64 QAM	1@1	11.34	9.54	0.0090
77	30	100	633334	3500.01	DFT-s-OFDM 64 QAM	1@271	11.03	9.23	0.0084
77	30	100	633334	3500.01	DFT-s-OFDM 256 QAM	135@67	12.11	10.31	0.0107
77	30	100	633334	3500.01	DFT-s-OFDM 256 QAM	1@1	11.53	9.73	0.0094
77	30	100	633334	3500.01	DFT-s-OFDM 256 QAM	1@271	11.27	9.47	0.0089
77	30	100	633334	3500.01	CP-OFDM QPSK	137@68	12.07	10.27	0.0106
77	30	100	633334	3500.01	CP-OFDM QPSK	1@1	11.5	9.7	0.0093
77	30	100	633334	3500.01	CP-OFDM QPSK	1@271	11.15	9.35	0.0086
77	30	20	630668	3460.02	DFT-s-OFDM PI/2 BPSK	1@1	11.93	10.13	0.0103
77	30	20	630668	3460.02	DFT-s-OFDM QPSK	1@1	11.99	10.19	0.0104
77	30	20	630668	3460.02	DFT-s-OFDM 16 QAM	1@1	12.07	10.27	0.0106
77	30	20	633334	3500.01	DFT-s-OFDM PI/2 BPSK	1@1	11.98	10.18	0.0104
77	30	20	633334	3500.01	DFT-s-OFDM QPSK	1@1	12.04	10.24	0.0106
77	30	20	633334	3500.01	DFT-s-OFDM 16 QAM	1@1	12.06	10.26	0.0106
77	30	20	636000	3540	DFT-s-OFDM PI/2 BPSK	1@1	11.98	10.18	0.0104
77	30	20	636000	3540	DFT-s-OFDM QPSK	1@1	12.01	10.21	0.0105
77	30	20	636000	3540	DFT-s-OFDM 16 QAM	1@1	12.08	10.28	0.0107
77	30	40	631334	3470.01	DFT-s-OFDM PI/2 BPSK	1@1	11.67	9.87	0.0097
77	30	40	631334	3470.01	DFT-s-OFDM QPSK	1@1	11.67	9.87	0.0097
77	30	40	631334	3470.01	DFT-s-OFDM 16 QAM	1@1	11.69	9.89	0.0097
77	30	40	633334	3500.01	DFT-s-OFDM PI/2 BPSK	1@1	11.71	9.91	0.0098
77	30	40	633334	3500.01	DFT-s-OFDM QPSK	1@1	11.71	9.91	0.0098
77	30	40	633334	3500.01	DFT-s-OFDM 16 QAM	1@1	11.7	9.9	0.0098
77	30	40	635332	3529.98	DFT-s-OFDM PI/2 BPSK	1@1	11.71	9.91	0.0098
77	30	40	635332	3529.98	DFT-s-OFDM QPSK	1@1	11.73	9.93	0.0098
77	30	40	635332	3529.98	DFT-s-OFDM 16 QAM	1@1	11.71	9.91	0.0098

Frequency Stability

NR Band	SCS (kHz)	Bandwidth (MHz)	Arfcn	Freq (MHz)	Modulation	RB	Deviation (ppm)	Verdict	Environment
77	30	20	633334	3500.01	DFT-s-OFDM PI/2 BPSK	50@0	-0.0047	PASS	NV
77	30	20	633334	3500.01	DFT-s-OFDM PI/2 BPSK	50@0	-0.0005	PASS	LV
77	30	20	633334	3500.01	DFT-s-OFDM PI/2 BPSK	50@0	-0.0055	PASS	HV
77	30	20	633334	3500.01	DFT-s-OFDM PI/2 BPSK	50@0	-0.0037	PASS	-30°C
77	30	20	633334	3500.01	DFT-s-OFDM PI/2 BPSK	50@0	-0.0124	PASS	-20°C
77	30	20	633334	3500.01	DFT-s-OFDM PI/2 BPSK	50@0	-0.0075	PASS	-10°C
77	30	20	633334	3500.01	DFT-s-OFDM PI/2 BPSK	50@0	-0.0058	PASS	0°C
77	30	20	633334	3500.01	DFT-s-OFDM PI/2 BPSK	50@0	-0.0043	PASS	10°C
77	30	20	633334	3500.01	DFT-s-OFDM PI/2 BPSK	50@0	-0.0119	PASS	20°C
77	30	20	633334	3500.01	DFT-s-OFDM PI/2 BPSK	50@0	-0.0006	PASS	30°C
77	30	20	633334	3500.01	DFT-s-OFDM PI/2 BPSK	50@0	-0.0052	PASS	40°C
77	30	20	633334	3500.01	DFT-s-OFDM PI/2 BPSK	50@0	-0.0074	PASS	50°C

Peak to Average Ratio

NR Band	SCS (kHz)	Bandwidth (MHz)	Arfcn	Freq (MHz)	Modulation	RB	Result (dB)	Limit (dB)	Verdict
77	30	20	633334	3500.01	DFT-s-OFDM PI/2 BPSK	50@0	4.44	13	PASS
77	30	20	633334	3500.01	DFT-s-OFDM PI/2 BPSK	1@0	4.35	13	PASS
77	30	20	633334	3500.01	DFT-s-OFDM QPSK	50@0	5.66	13	PASS
77	30	20	633334	3500.01	DFT-s-OFDM QPSK	1@0	5.34	13	PASS

N77(20M)_DFT-s-OFDM_PI_2-BPSK_Outer_Full_Mid_CH

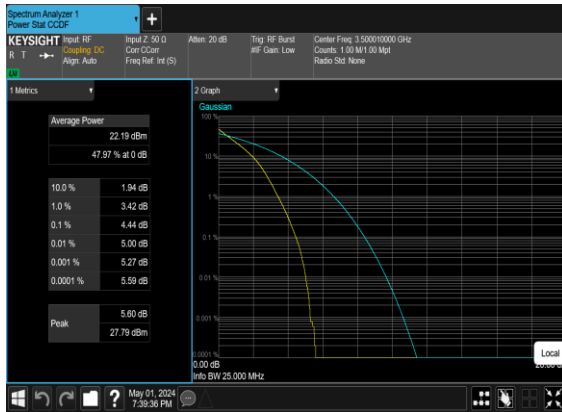

N77(20M)_DFT-s-OFDM_PI_2-BPSK_Edge_1RB_Left_Mid_CH

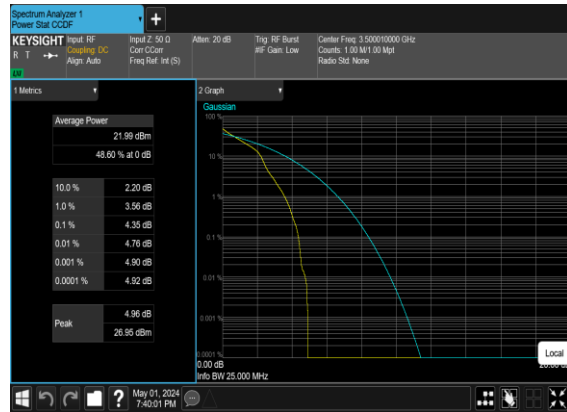

N77(20M)_DFT-s-OFDM_QPSK_Outer_Full_Mid_CH



N77(20M)_DFT-s-OFDM_QPSK_Edge_1RB_Left_Mid_CH

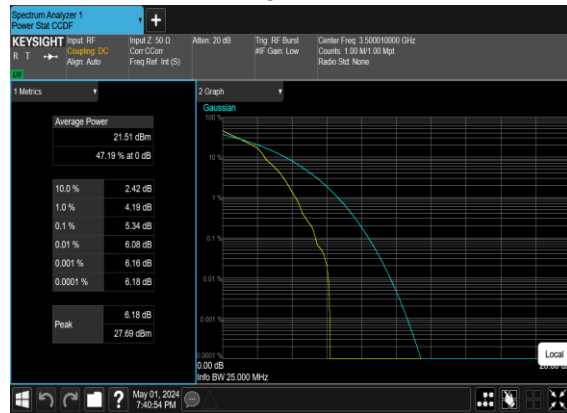

Occupied Bandwidth

NR Band	SCS (kHz)	Bandwidth (MHz)	Arfcn	Freq (MHz)	Modulation	RB	OBW (MHz)	26dB BW (MHz)
77	30	20	633334	3500.01	CP-OFDM QPSK	51@0	18.154	19.31
77	30	20	633334	3500.01	CP-OFDM 16 QAM	51@0	18.205	18.99
77	30	20	633334	3500.01	CP-OFDM 64 QAM	51@0	18.128	19.17
77	30	20	633334	3500.01	CP-OFDM 256 QAM	51@0	18.151	19.06
77	30	40	633334	3500.01	CP-OFDM QPSK	106@0	37.778	39.28
77	30	40	633334	3500.01	CP-OFDM 16 QAM	106@0	37.815	39.29
77	30	40	633334	3500.01	CP-OFDM 64 QAM	106@0	37.793	39.38
77	30	40	633334	3500.01	CP-OFDM 256 QAM	106@0	37.814	39.37
77	30	100	633334	3500.01	CP-OFDM QPSK	273@0	96.976	100.5
77	30	100	633334	3500.01	CP-OFDM 16 QAM	273@0	97.208	100.4
77	30	100	633334	3500.01	CP-OFDM 64 QAM	273@0	97.235	100.5
77	30	100	633334	3500.01	CP-OFDM 256 QAM	273@0	97.255	100.4

N77(20M)_CP-OFDM_QPSK_Outer_Full_Mid_CH

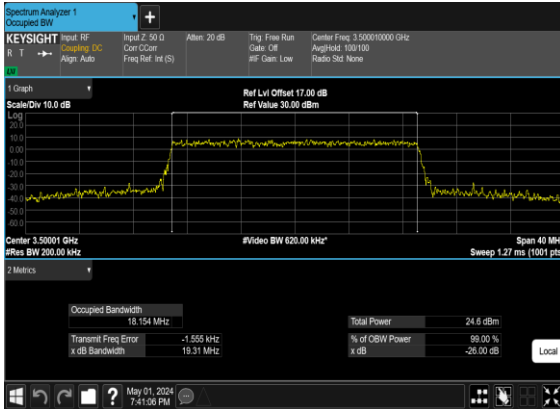

N77(20M)_CP-OFDM_16QAM_Outer_Full_Mid_CH

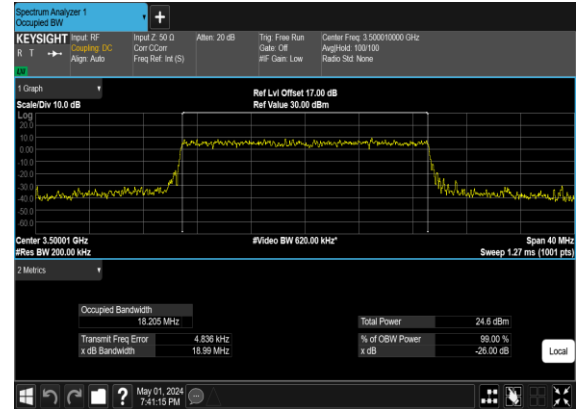

N77(20M)_CP-OFDM_64QAM_Outer_Full_Mid_CH

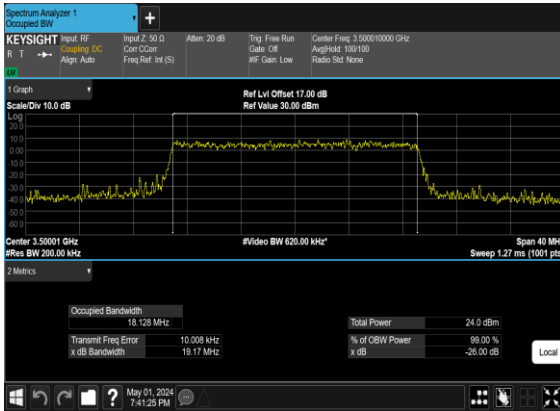

N77(20M)_CP-OFDM_256QAM_Outer_Full_Mid_CH

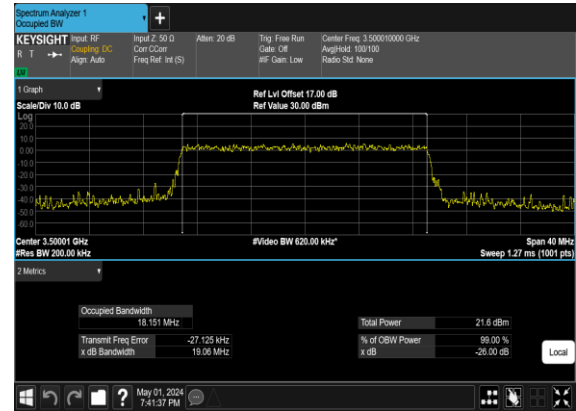

N77(40M)_CP-OFDM_QPSK_Outer_Full_Mid_CH

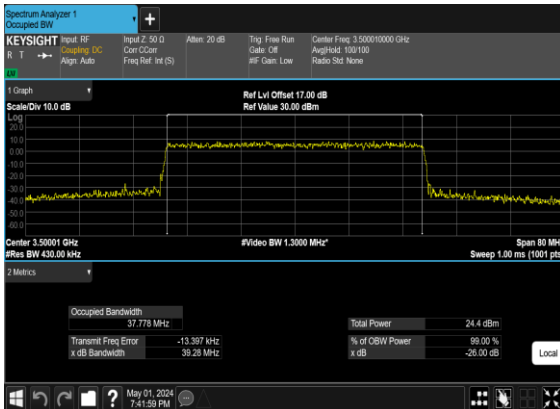

N77(40M)_CP-OFDM_16QAM_Outer_Full_Mid_CH

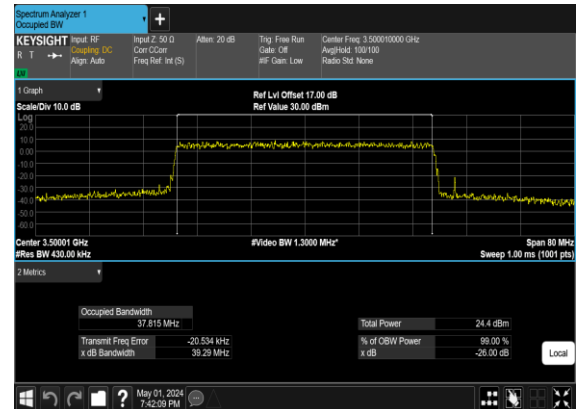

N77(40M)_CP-OFDM_64
QAM_Outer_Full_Mid_CH

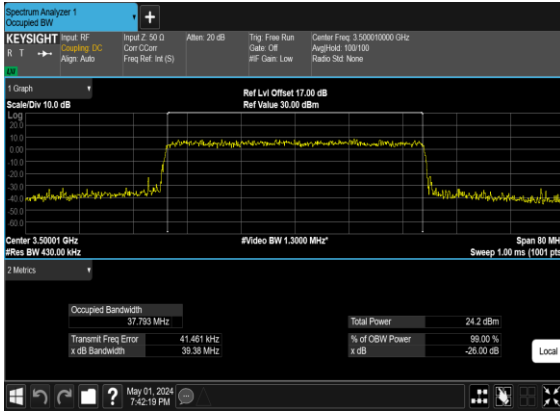

N77(40M)_CP-OFDM_256
QAM_Outer_Full_Mid_CH

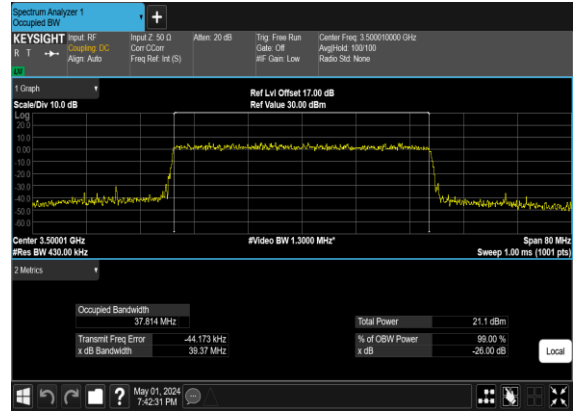

N77(100M)_CP-
OFDM_QPSK_Outer_Full_Mid_CH

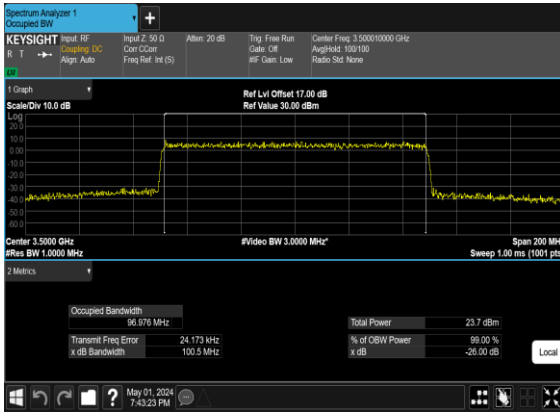

N77(100M)_CP-OFDM_16
QAM_Outer_Full_Mid_CH

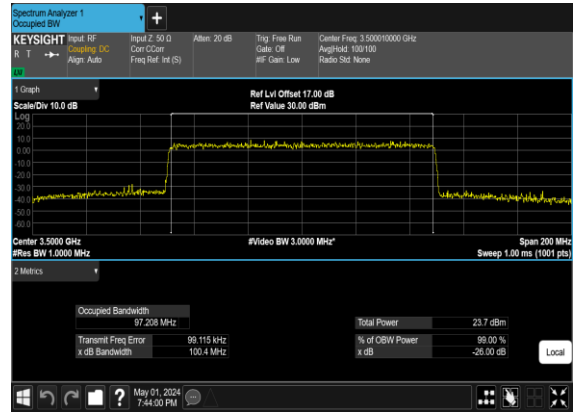

N77(100M)_CP-OFDM_64
QAM_Outer_Full_Mid_CH

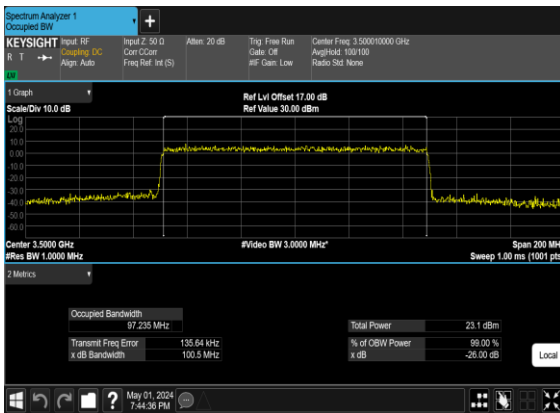

N77(100M)_CP-OFDM_256
QAM_Outer_Full_Mid_CH

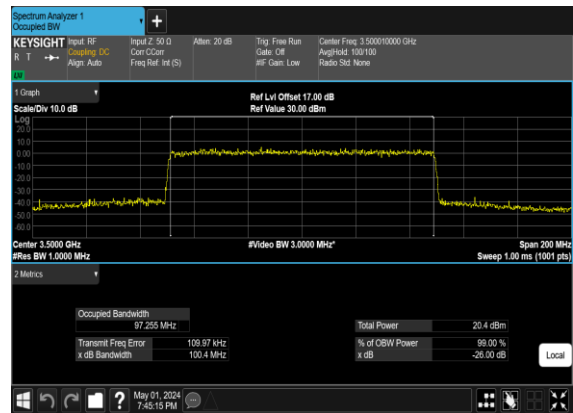

Conducted Spurious Emissions

NR Band	SCS (kHz)	Bandwidth (MHz)	Arfcn	Freq (MHz)	Modulation	RB	Result	Verdict
77	30	20	630668	3460.02	DFT-s-OFDM BPSK	1@0	see graph	---
77	30	20	630668	3460.02	DFT-s-OFDM BPSK	1@0	see graph	PASS
77	30	20	630668	3460.02	DFT-s-OFDM BPSK	1@0	see graph	PASS
77	30	20	630668	3460.02	DFT-s-OFDM QPSK	1@0	see graph	---
77	30	20	630668	3460.02	DFT-s-OFDM QPSK	1@0	see graph	PASS
77	30	20	630668	3460.02	DFT-s-OFDM QPSK	1@0	see graph	PASS
77	30	20	633334	3500.01	DFT-s-OFDM BPSK	1@0	see graph	---
77	30	20	633334	3500.01	DFT-s-OFDM BPSK	1@0	see graph	PASS
77	30	20	633334	3500.01	DFT-s-OFDM BPSK	1@0	see graph	PASS
77	30	20	633334	3500.01	DFT-s-OFDM QPSK	1@0	see graph	---
77	30	20	633334	3500.01	DFT-s-OFDM QPSK	1@0	see graph	PASS
77	30	20	633334	3500.01	DFT-s-OFDM QPSK	1@0	see graph	PASS
77	30	20	636000	3540.0	DFT-s-OFDM BPSK	1@0	see graph	---
77	30	20	636000	3540.0	DFT-s-OFDM BPSK	1@0	see graph	PASS
77	30	20	636000	3540.0	DFT-s-OFDM BPSK	1@0	see graph	PASS
77	30	20	636000	3540.0	DFT-s-OFDM QPSK	1@0	see graph	---
77	30	20	636000	3540.0	DFT-s-OFDM QPSK	1@0	see graph	PASS
77	30	20	636000	3540.0	DFT-s-OFDM QPSK	1@0	see graph	PASS
77	30	20	636000	3540.0	DFT-s-OFDM QPSK	1@0	see graph	PASS
77	30	40	631334	3470.01	DFT-s-OFDM BPSK	1@0	see graph	---
77	30	40	631334	3470.01	DFT-s-OFDM BPSK	1@0	see graph	PASS
77	30	40	631334	3470.01	DFT-s-OFDM BPSK	1@0	see graph	PASS
77	30	40	631334	3470.01	DFT-s-OFDM QPSK	1@0	see graph	---
77	30	40	631334	3470.01	DFT-s-OFDM QPSK	1@0	see graph	PASS
77	30	40	631334	3470.01	DFT-s-OFDM QPSK	1@0	see graph	PASS
77	30	40	633334	3500.01	DFT-s-OFDM BPSK	1@0	see graph	---
77	30	40	633334	3500.01	DFT-s-OFDM BPSK	1@0	see graph	PASS
77	30	40	633334	3500.01	DFT-s-OFDM BPSK	1@0	see graph	PASS
77	30	40	633334	3500.01	DFT-s-OFDM QPSK	1@0	see graph	---
77	30	40	633334	3500.01	DFT-s-OFDM QPSK	1@0	see graph	PASS
77	30	40	633334	3500.01	DFT-s-OFDM QPSK	1@0	see graph	PASS

77	30	40	635332	3529.98	DFT-s-OFDM BPSK	1@0	see graph	---
77	30	40	635332	3529.98	DFT-s-OFDM BPSK	1@0	see graph	PASS
77	30	40	635332	3529.98	DFT-s-OFDM BPSK	1@0	see graph	PASS
77	30	40	635332	3529.98	DFT-s-OFDM QPSK	1@0	see graph	---
77	30	40	635332	3529.98	DFT-s-OFDM QPSK	1@0	see graph	PASS
77	30	40	635332	3529.98	DFT-s-OFDM QPSK	1@0	see graph	PASS
77	30	100	633334	3500.01	DFT-s-OFDM BPSK	1@0	see graph	---
77	30	100	633334	3500.01	DFT-s-OFDM BPSK	1@0	see graph	PASS
77	30	100	633334	3500.01	DFT-s-OFDM BPSK	1@0	see graph	PASS
77	30	100	633334	3500.01	DFT-s-OFDM QPSK	1@0	see graph	---
77	30	100	633334	3500.01	DFT-s-OFDM QPSK	1@0	see graph	PASS
77	30	100	633334	3500.01	DFT-s-OFDM QPSK	1@0	see graph	PASS

N77(20M)_DFT-s-OFDM_BPSK_Edge_1RB_Left_Low_CH

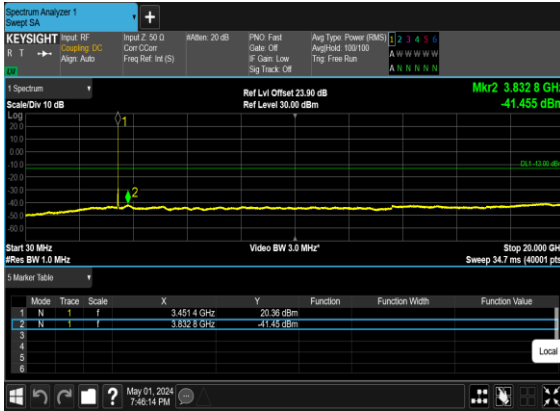

N77(20M)_DFT-s-OFDM_BPSK_Edge_1RB_Left_Low_CH

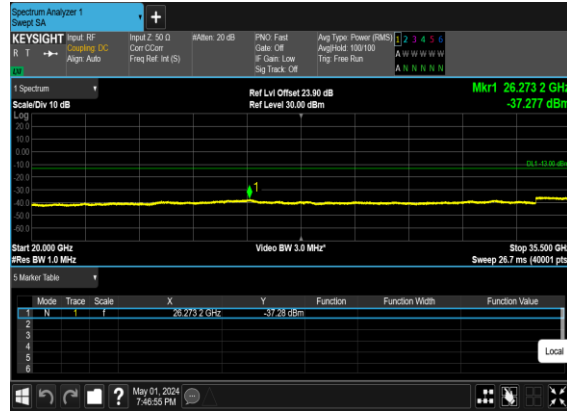

N77(20M)_DFT-s-OFDM_QPSK_Edge_1RB_Left_Low_CH

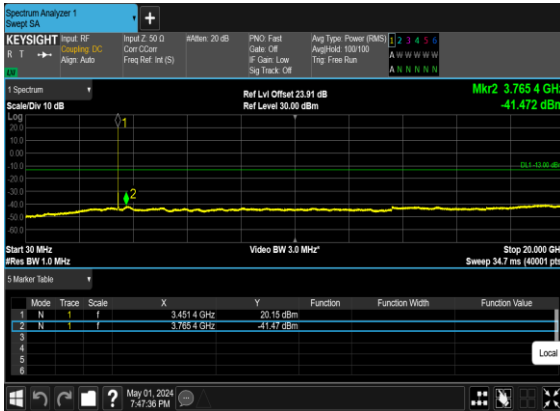

N77(20M)_DFT-s-OFDM_QPSK_Edge_1RB_Left_Low_CH

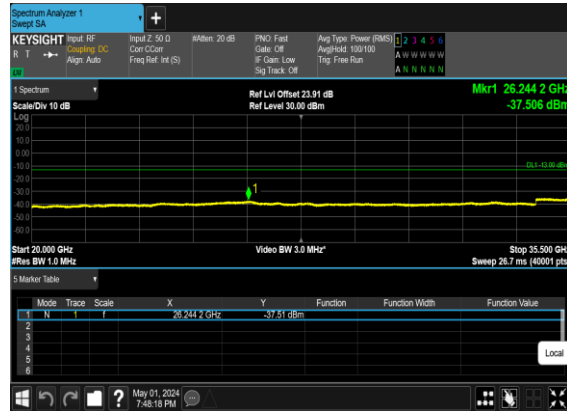

N77(20M)_DFT-s-OFDM_BPSK_Edge_1RB_Left_Mid_CH

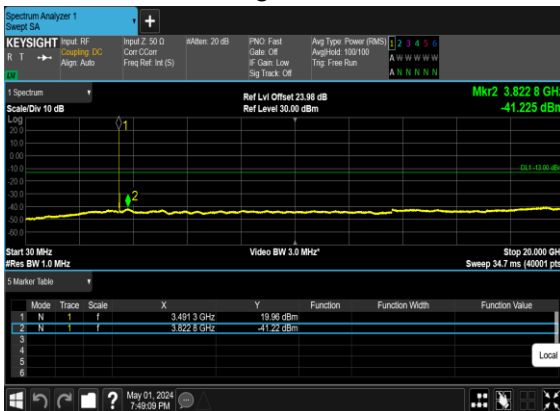

N77(20M)_DFT-s-OFDM_BPSK_Edge_1RB_Left_Mid_CH

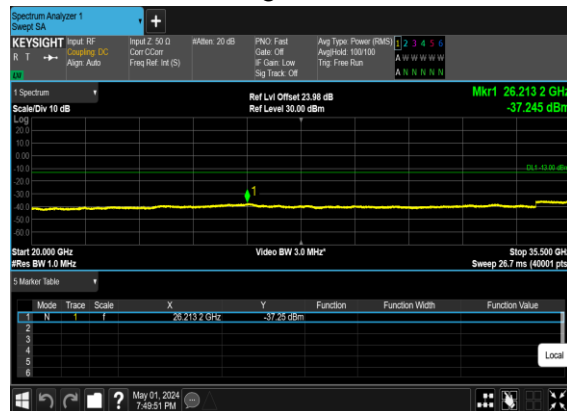

N77(20M)_DFT-s-OFDM_QPSK_Edge_1RB_Left_Mid_CH



N77(20M)_DFT-s-OFDM_QPSK_Edge_1RB_Left_Mid_CH

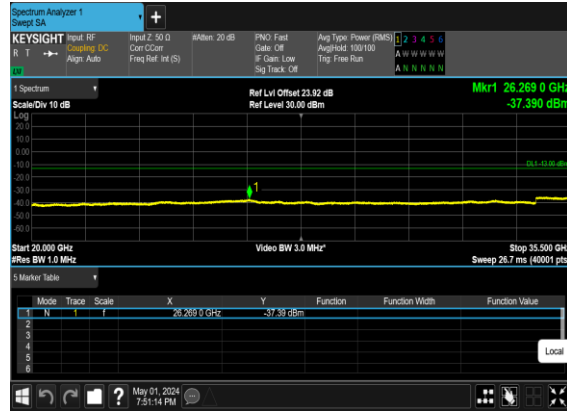

N77(20M)_DFT-s-OFDM_BPSK_Edge_1RB_Left_High_CH

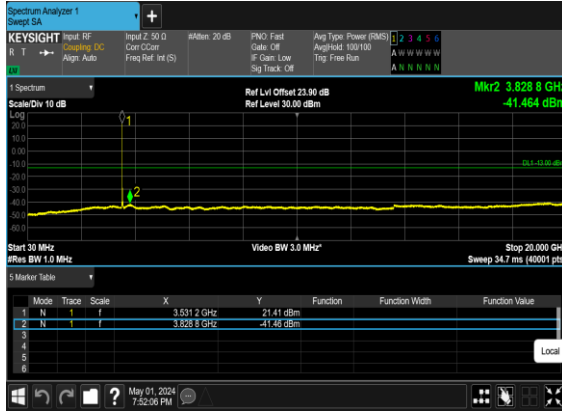

N77(20M)_DFT-s-OFDM_BPSK_Edge_1RB_Left_High_CH

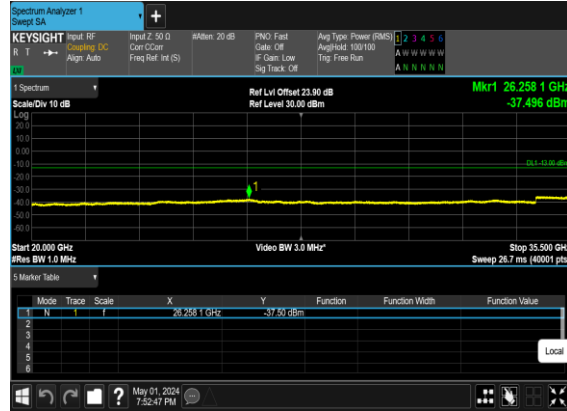

N77(20M)_DFT-s-OFDM_QPSK_Edge_1RB_Left_High_CH

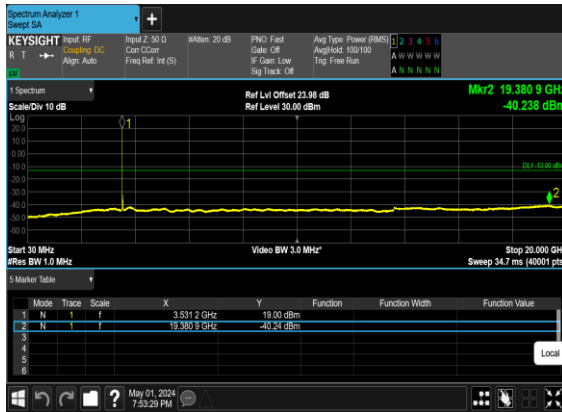

N77(20M)_DFT-s-OFDM_QPSK_Edge_1RB_Left_High_CH

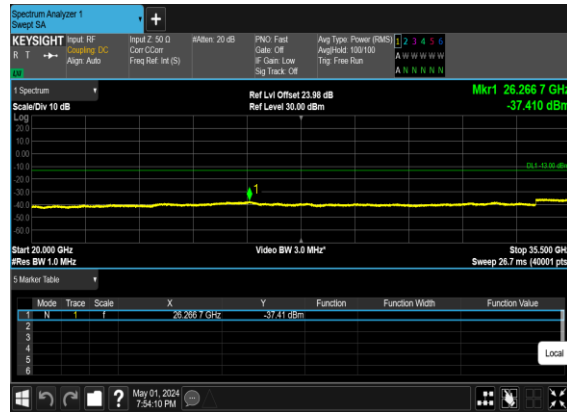

N77(40M)_DFT-s-OFDM_BPSK_Edge_1RB_Left_Low_CH

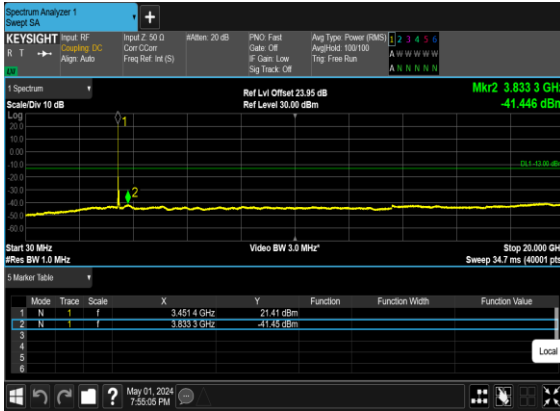

N77(40M)_DFT-s-OFDM_BPSK_Edge_1RB_Left_Low_CH

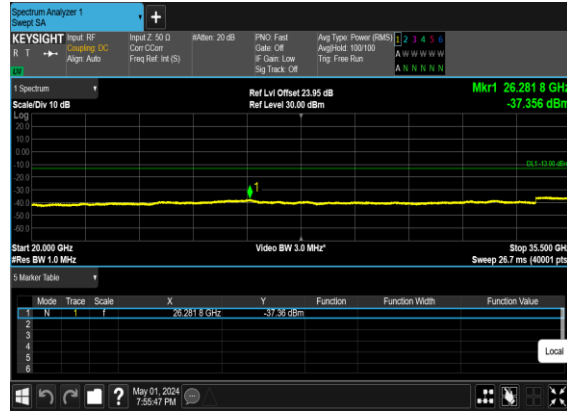

N77(40M)_DFT-s-OFDM_QPSK_Edge_1RB_Left_Low_CH

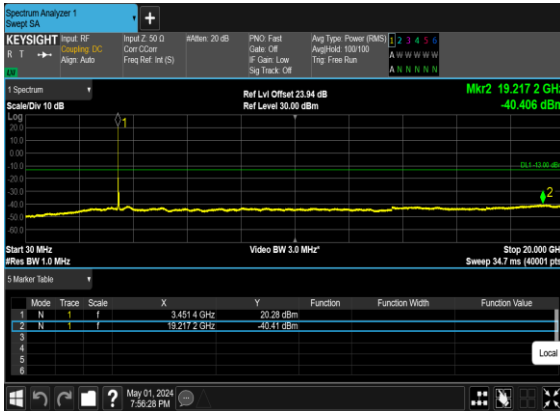

N77(40M)_DFT-s-OFDM_QPSK_Edge_1RB_Left_Low_CH

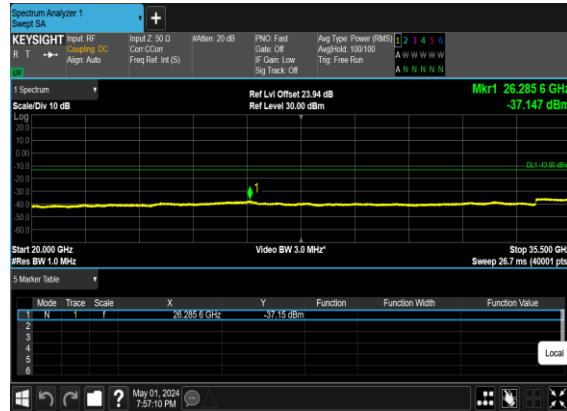

N77(40M)_DFT-s-OFDM_BPSK_Edge_1RB_Left_Mid_CH

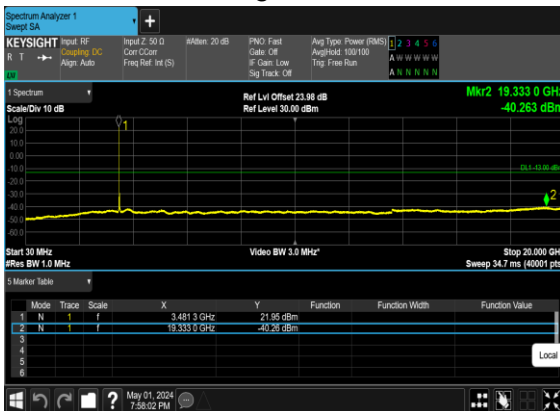

N77(40M)_DFT-s-OFDM_BPSK_Edge_1RB_Left_Mid_CH

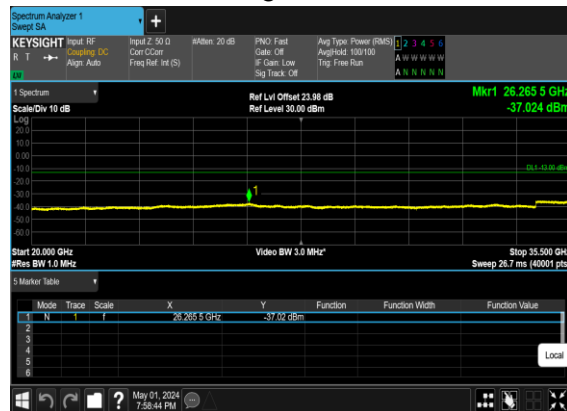

N77(40M)_DFT-s-OFDM_QPSK_Edge_1RB_Left_Mid_CH

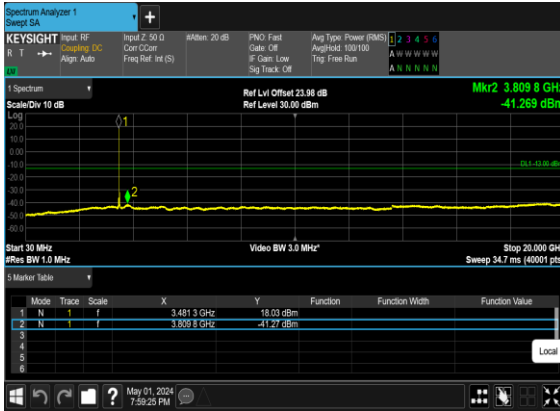

N77(40M)_DFT-s-OFDM_QPSK_Edge_1RB_Left_Mid_CH

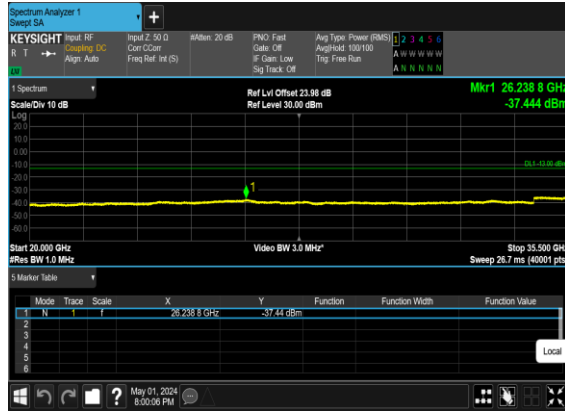

N77(40M)_DFT-s-OFDM_BPSK_Edge_1RB_Left_High_CH

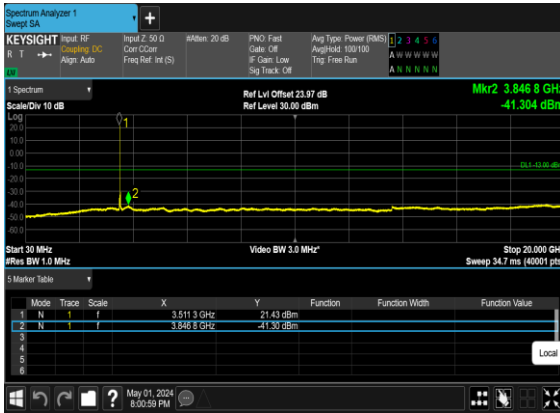

N77(40M)_DFT-s-OFDM_BPSK_Edge_1RB_Left_High_CH

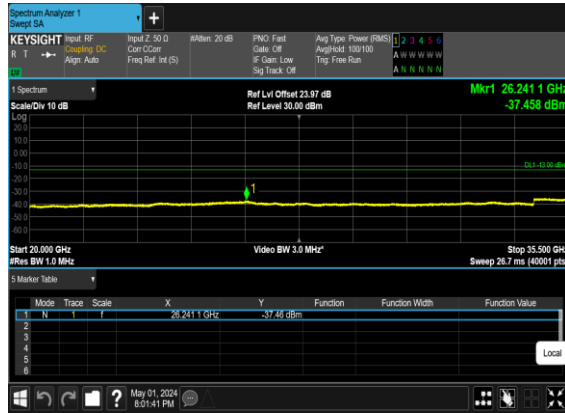

N77(40M)_DFT-s-OFDM_QPSK_Edge_1RB_Left_High_CH



N77(40M)_DFT-s-OFDM_QPSK_Edge_1RB_Left_High_CH

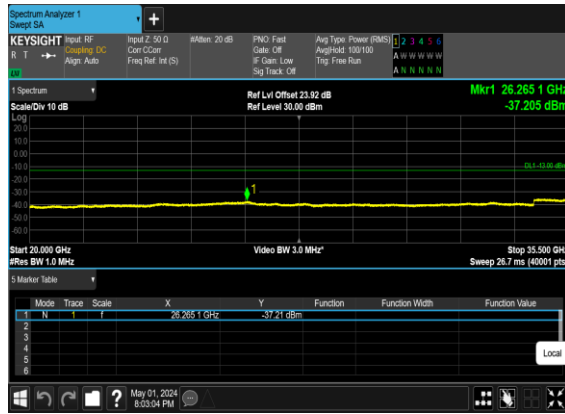

N77(100M)_DFT-s-OFDM_BPSK_Edge_1RB_Left_Mid_CH

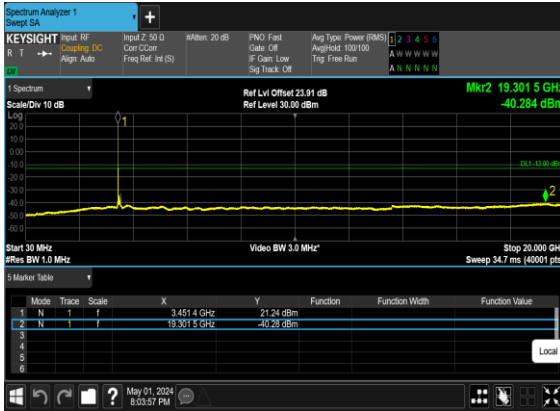

N77(100M)_DFT-s-OFDM_BPSK_Edge_1RB_Left_Mid_CH

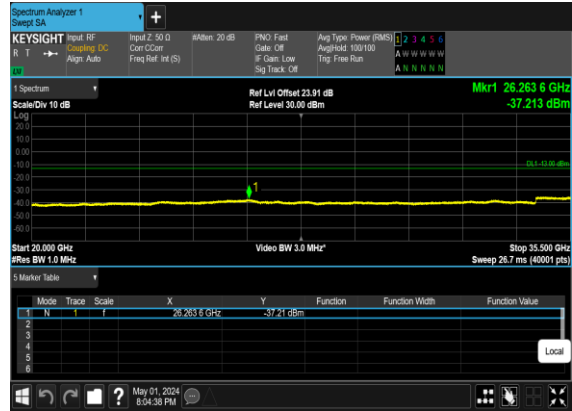

N77(100M)_DFT-s-OFDM_QPSK_Edge_1RB_Left_Mid_CH

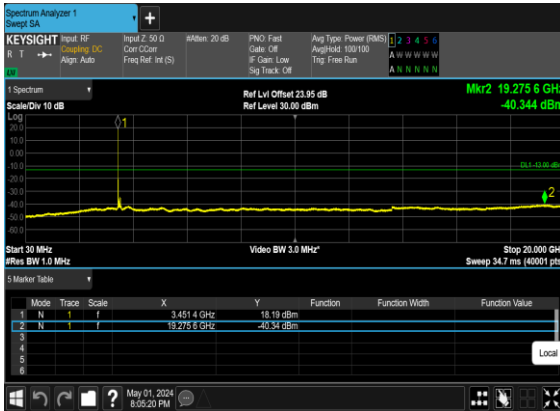

N77(100M)_DFT-s-OFDM_QPSK_Edge_1RB_Left_Mid_CH



Conducted Band Edge

NR Band	SCS (kHz)	Bandwidth (MHz)	Arfcn	Freq (MHz)	Modulation	RB	Result	Verdict
77	30	20	630668	3460.02	DFT-s-OFDM BPSK	1@0	see graph	PASS
77	30	20	630668	3460.02	DFT-s-OFDM QPSK	1@0	see graph	PASS
77	30	20	630668	3460.02	DFT-s-OFDM BPSK	50@0	see graph	PASS
77	30	20	630668	3460.02	DFT-s-OFDM QPSK	50@0	see graph	PASS
77	30	20	636000	3540.0	DFT-s-OFDM BPSK	1@50	see graph	PASS
77	30	20	636000	3540.0	DFT-s-OFDM QPSK	1@50	see graph	PASS
77	30	20	636000	3540.0	DFT-s-OFDM BPSK	50@0	see graph	PASS
77	30	20	636000	3540.0	DFT-s-OFDM QPSK	50@0	see graph	PASS
77	30	40	631334	3470.01	DFT-s-OFDM BPSK	1@0	see graph	PASS
77	30	40	631334	3470.01	DFT-s-OFDM QPSK	1@0	see graph	PASS
77	30	40	631334	3470.01	DFT-s-OFDM BPSK	100@0	see graph	PASS
77	30	40	631334	3470.01	DFT-s-OFDM QPSK	100@0	see graph	PASS
77	30	40	635332	3529.98	DFT-s-OFDM BPSK	1@105	see graph	PASS
77	30	40	635332	3529.98	DFT-s-OFDM QPSK	1@105	see graph	PASS
77	30	40	635332	3529.98	DFT-s-OFDM BPSK	100@0	see graph	PASS
77	30	40	635332	3529.98	DFT-s-OFDM QPSK	100@0	see graph	PASS
77	30	100	633334	3500.01	DFT-s-OFDM BPSK	1@0	see graph	PASS
77	30	100	633334	3500.01	DFT-s-OFDM QPSK	1@0	see graph	PASS
77	30	100	633334	3500.01	DFT-s-OFDM BPSK	1@272	see graph	PASS
77	30	100	633334	3500.01	DFT-s-OFDM QPSK	1@272	see graph	PASS
77	30	100	633334	3500.01	DFT-s-OFDM BPSK	270@0	see graph	PASS
77	30	100	633334	3500.01	DFT-s-OFDM QPSK	270@0	see graph	PASS

N77(20M)_DFT-s-OFDM_BPSK_Edge_1RB_Left_Low_CH

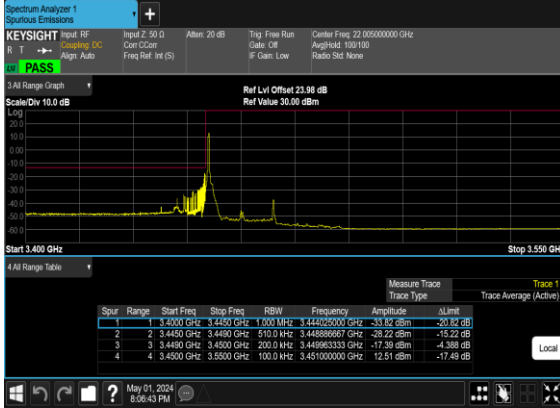

N77(20M)_DFT-s-OFDM_QPSK_Edge_1RB_Left_Low_CH

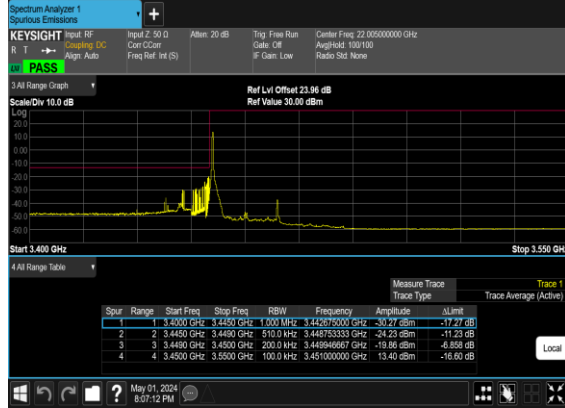

N77(20M)_DFT-s-OFDM_BPSK_Outer_Full_Low_CH

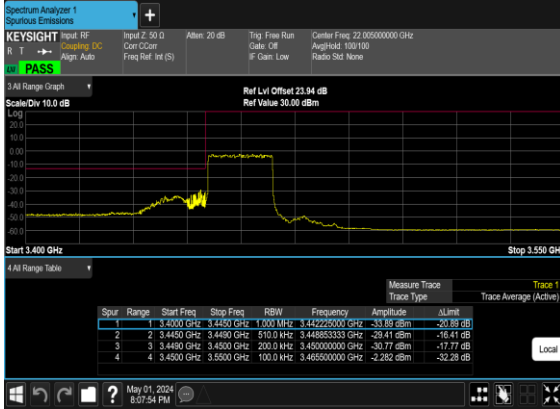

N77(20M)_DFT-s-OFDM_QPSK_Outer_Full_Low_CH

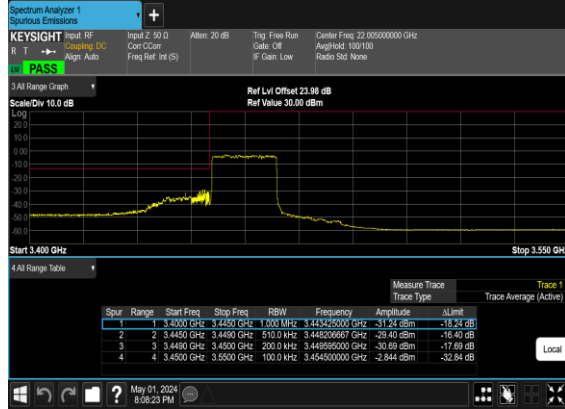

N77(20M)_DFT-s-OFDM_BPSK_Edge_1RB_Right_High_CH



N77(20M)_DFT-s-OFDM_QPSK_Edge_1RB_Right_High_CH

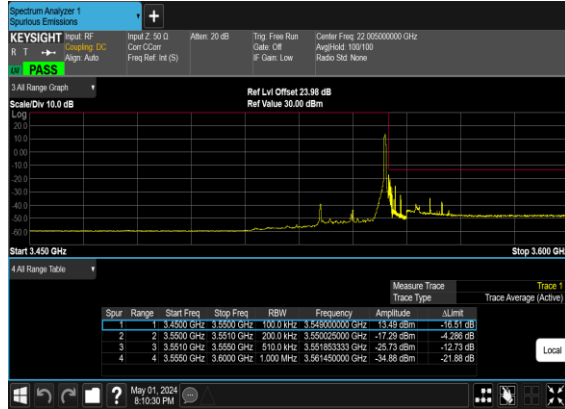

N77(20M)_DFT-s-OFDM_BPSK_Outer_Full_High_CH

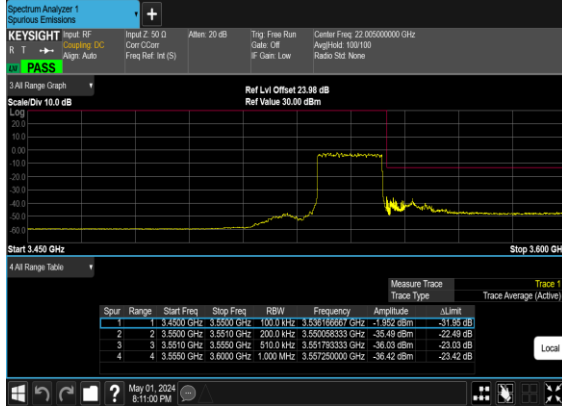

N77(20M)_DFT-s-OFDM_QPSK_Outer_Full_High_CH

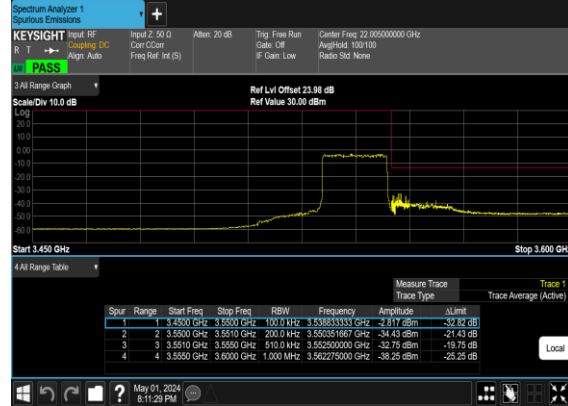

N77(40M)_DFT-s-OFDM_BPSK_Edge_1RB_Left_Low_CH

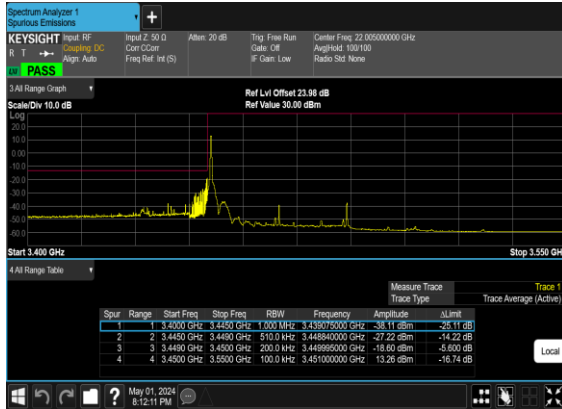

N77(40M)_DFT-s-OFDM_QPSK_Edge_1RB_Left_Low_CH

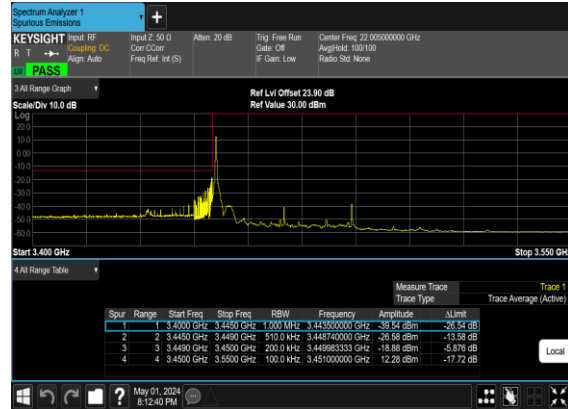

N77(40M)_DFT-s-OFDM_BPSK_Outer_Full_Low_CH

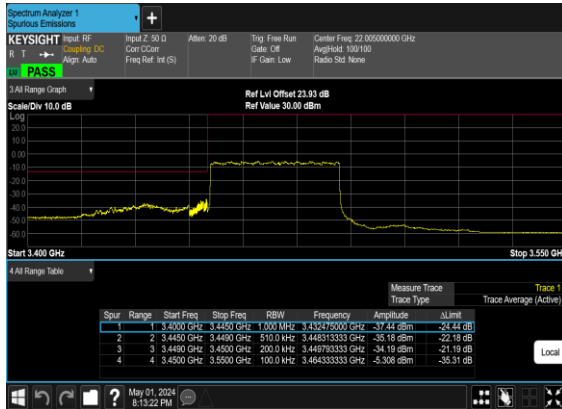

N77(40M)_DFT-s-OFDM_QPSK_Outer_Full_Low_CH

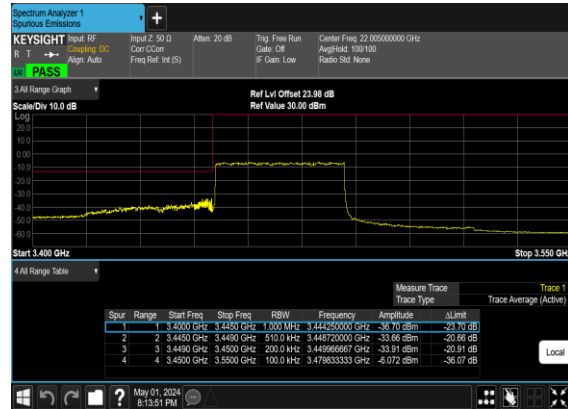

N77(40M)_DFT-s-OFDM_BPSK_Edge_1RB_Right_High_CH



N77(40M)_DFT-s-OFDM_QPSK_Edge_1RB_Right_High_CH

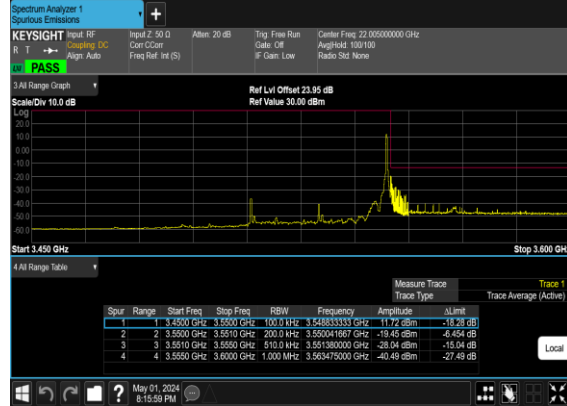

N77(40M)_DFT-s-OFDM_BPSK_Outer_Full_High_CH



N77(40M)_DFT-s-OFDM_QPSK_Outer_Full_High_CH

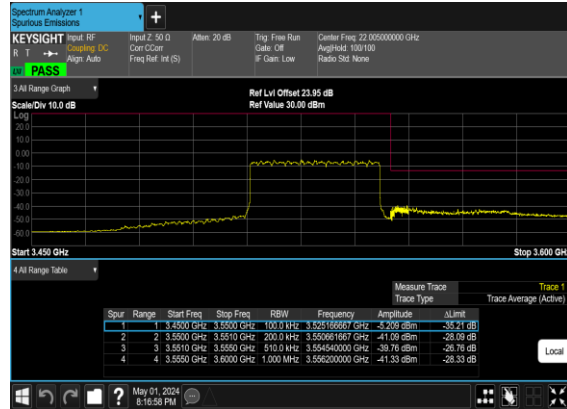

N77(100M)_DFT-s-OFDM_BPSK_Edge_1RB_Left_Mid_CH

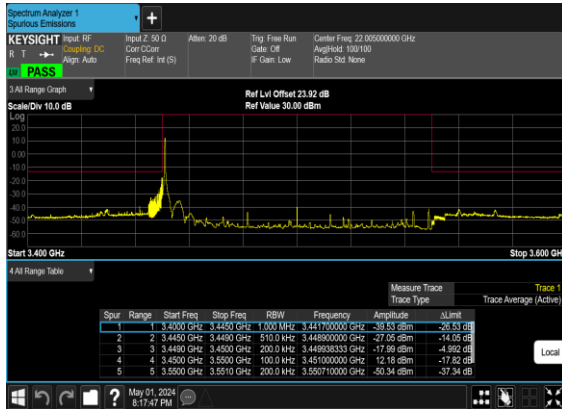

N77(100M)_DFT-s-OFDM_QPSK_Edge_1RB_Left_Mid_CH

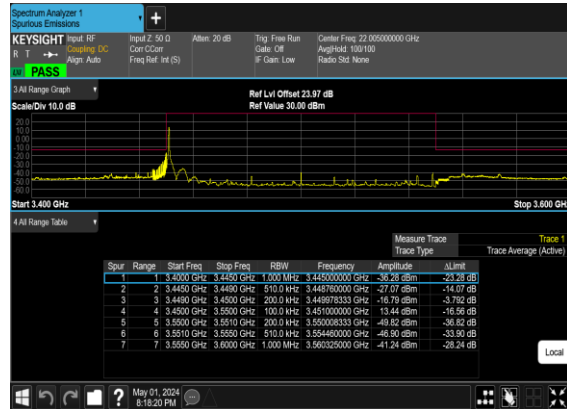

N77(100M)_DFT-s-OFDM_BPSK_Edge_1RB_Right_Mid_CH

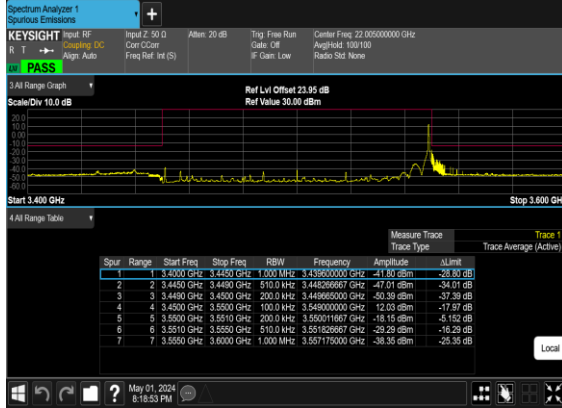

N77(100M)_DFT-s-OFDM_QPSK_Edge_1RB_Right_Mid_CH

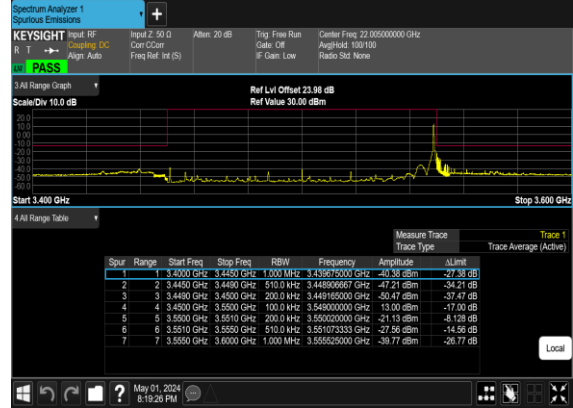

N77(100M)_DFT-s-OFDM_BPSK_Outer_Full_Mid_CH

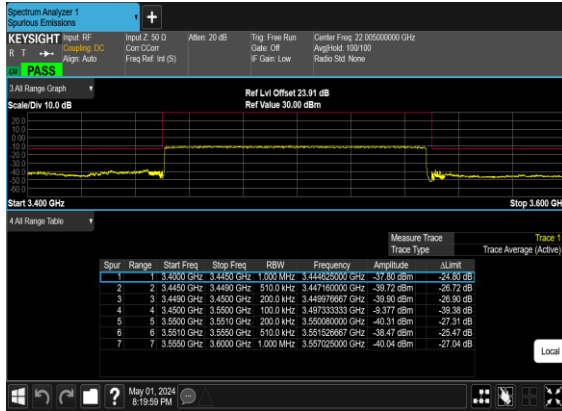

N77(100M)_DFT-s-OFDM_QPSK_Outer_Full_Mid_CH

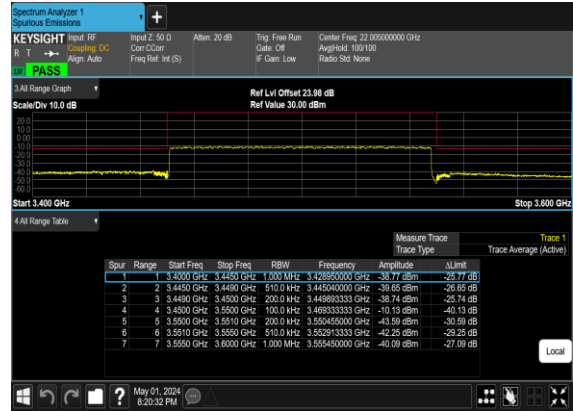

FR1 N78 NSA

LTE Band: 41, LTE BW: 10M, LTE ARFCN: Mid

Transmitter Conducted Output Power And EIRP, (G_T - L_C)=-1.8dB

NR Band	SCS	BandWidth	Arfcn	Freq(MHz)	Modulation	RB	Conducted Power(dBm)	EIRP (dBm)	EIRP(W)
78	30	80	632668	3490.02	DFT-s-OFDM PI/2 BPSK	108@54	11.99	10.19	0.0104
78	30	80	632668	3490.02	DFT-s-OFDM PI/2 BPSK	1@1	11.64	9.84	0.0096
78	30	80	632668	3490.02	DFT-s-OFDM PI/2 BPSK	1@215	11.2	9.4	0.0087
78	30	80	632668	3490.02	DFT-s-OFDM QPSK	108@54	12.01	10.21	0.0105
78	30	80	632668	3490.02	DFT-s-OFDM QPSK	1@1	11.76	9.96	0.0099
78	30	80	632668	3490.02	DFT-s-OFDM QPSK	1@215	11.33	9.53	0.0090
78	30	80	632668	3490.02	DFT-s-OFDM 16 QAM	108@54	12.04	10.24	0.0106
78	30	80	632668	3490.02	DFT-s-OFDM 16 QAM	1@1	11.65	9.85	0.0097
78	30	80	632668	3490.02	DFT-s-OFDM 16 QAM	1@215	11.35	9.55	0.0090
78	30	80	632668	3490.02	DFT-s-OFDM 64 QAM	108@54	12.03	10.23	0.0105
78	30	80	632668	3490.02	DFT-s-OFDM 64 QAM	1@1	11.38	9.58	0.0091
78	30	80	632668	3490.02	DFT-s-OFDM 64 QAM	1@215	10.95	9.15	0.0082
78	30	80	632668	3490.02	DFT-s-OFDM 256 QAM	108@54	12.07	10.27	0.0106
78	30	80	632668	3490.02	DFT-s-OFDM 256 QAM	1@1	11.62	9.82	0.0096
78	30	80	632668	3490.02	DFT-s-OFDM 256 QAM	1@215	11.19	9.39	0.0087
78	30	80	632668	3490.02	CP-OFDM QPSK	109@54	12.04	10.24	0.0106
78	30	80	632668	3490.02	CP-OFDM QPSK	1@1	11.62	9.82	0.0096
78	30	80	632668	3490.02	CP-OFDM QPSK	1@215	11.2	9.4	0.0087
78	30	80	633334	3500.01	DFT-s-OFDM PI/2 BPSK	108@54	11.95	10.15	0.0104
78	30	80	633334	3500.01	DFT-s-OFDM PI/2 BPSK	1@1	11.54	9.74	0.0094
78	30	80	633334	3500.01	DFT-s-OFDM PI/2 BPSK	1@215	11.11	9.31	0.0085
78	30	80	633334	3500.01	DFT-s-OFDM QPSK	108@54	11.96	10.16	0.0104
78	30	80	633334	3500.01	DFT-s-OFDM QPSK	1@1	11.64	9.84	0.0096
78	30	80	633334	3500.01	DFT-s-OFDM QPSK	1@215	11.23	9.43	0.0088
78	30	80	633334	3500.01	DFT-s-OFDM 16 QAM	108@54	12.02	10.22	0.0105
78	30	80	633334	3500.01	DFT-s-OFDM 16 QAM	1@1	11.63	9.83	0.0096
78	30	80	633334	3500.01	DFT-s-OFDM 16 QAM	1@215	11.42	9.62	0.0092
78	30	80	633334	3500.01	DFT-s-OFDM 64 QAM	108@54	12.03	10.23	0.0105
78	30	80	633334	3500.01	DFT-s-OFDM 64 QAM	1@1	11.33	9.53	0.0090
78	30	80	633334	3500.01	DFT-s-OFDM 64 QAM	1@215	10.91	9.11	0.0081
78	30	80	633334	3500.01	DFT-s-OFDM 256 QAM	108@54	12.02	10.22	0.0105
78	30	80	633334	3500.01	DFT-s-OFDM 256 QAM	1@1	11.57	9.77	0.0095
78	30	80	633334	3500.01	DFT-s-OFDM 256 QAM	1@215	11.21	9.41	0.0087
78	30	80	633334	3500.01	CP-OFDM QPSK	109@54	12.03	10.23	0.0105
78	30	80	633334	3500.01	CP-OFDM QPSK	1@1	11.56	9.76	0.0095
78	30	80	633334	3500.01	CP-OFDM QPSK	1@215	11.13	9.33	0.0086

78	30	80	634000	3510	DFT-s-OFDM PI/2 BPSK	108@54	11.93	10.13	0.0103
78	30	80	634000	3510	DFT-s-OFDM PI/2 BPSK	1@1	11.51	9.71	0.0094
78	30	80	634000	3510	DFT-s-OFDM PI/2 BPSK	1@215	11.17	9.37	0.0086
78	30	80	634000	3510	DFT-s-OFDM QPSK	108@54	11.96	10.16	0.0104
78	30	80	634000	3510	DFT-s-OFDM QPSK	1@1	11.62	9.82	0.0096
78	30	80	634000	3510	DFT-s-OFDM QPSK	1@215	11.29	9.49	0.0089
78	30	80	634000	3510	DFT-s-OFDM 16 QAM	108@54	12.01	10.21	0.0105
78	30	80	634000	3510	DFT-s-OFDM 16 QAM	1@1	11.65	9.85	0.0097
78	30	80	634000	3510	DFT-s-OFDM 16 QAM	1@215	11.46	9.66	0.0092
78	30	80	634000	3510	DFT-s-OFDM 64 QAM	108@54	12.02	10.22	0.0105
78	30	80	634000	3510	DFT-s-OFDM 64 QAM	1@1	11.33	9.53	0.0090
78	30	80	634000	3510	DFT-s-OFDM 64 QAM	1@215	10.96	9.16	0.0082
78	30	80	634000	3510	DFT-s-OFDM 256 QAM	108@54	12.01	10.21	0.0105
78	30	80	634000	3510	DFT-s-OFDM 256 QAM	1@1	11.49	9.69	0.0093
78	30	80	634000	3510	DFT-s-OFDM 256 QAM	1@215	11.14	9.34	0.0086
78	30	80	634000	3510	CP-OFDM QPSK	109@54	12	10.2	0.0105
78	30	80	634000	3510	CP-OFDM QPSK	1@1	11.52	9.72	0.0094
78	30	80	634000	3510	CP-OFDM QPSK	1@215	11.17	9.37	0.0086

Frequency Stability

NR Band	SCS (kHz)	Bandwidth (MHz)	Arfcn	Freq (MHz)	Modulation	RB	Deviation (ppm)	Verdict	Environment
78	30	80	633334	3500.01	DFT-s-OFDM PI/2 BPSK	216@0	-0.0074	PASS	NV
78	30	80	633334	3500.01	DFT-s-OFDM PI/2 BPSK	216@0	-0.0116	PASS	LV
78	30	80	633334	3500.01	DFT-s-OFDM PI/2 BPSK	216@0	-0.0087	PASS	HV
78	30	80	633334	3500.01	DFT-s-OFDM PI/2 BPSK	216@0	-0.0069	PASS	-30°C
78	30	80	633334	3500.01	DFT-s-OFDM PI/2 BPSK	216@0	-0.0106	PASS	-20°C
78	30	80	633334	3500.01	DFT-s-OFDM PI/2 BPSK	216@0	-0.0084	PASS	-10°C
78	30	80	633334	3500.01	DFT-s-OFDM PI/2 BPSK	216@0	-0.0091	PASS	0°C
78	30	80	633334	3500.01	DFT-s-OFDM PI/2 BPSK	216@0	-0.0075	PASS	10°C
78	30	80	633334	3500.01	DFT-s-OFDM PI/2 BPSK	216@0	-0.0112	PASS	20°C
78	30	80	633334	3500.01	DFT-s-OFDM PI/2 BPSK	216@0	-0.0037	PASS	30°C
78	30	80	633334	3500.01	DFT-s-OFDM PI/2 BPSK	216@0	-0.0089	PASS	40°C
78	30	80	633334	3500.01	DFT-s-OFDM PI/2 BPSK	216@0	-0.0045	PASS	50°C

Peak to Average Ratio

NR Band	SCS (kHz)	Bandwidth (MHz)	Arfcn	Freq (MHz)	Modulation	RB	Result (dB)	Limit (dB)	Verdict
78	30	80	633334	3500.01	DFT-s-OFDM PI/2 BPSK	216@0	7.32	13	PASS
78	30	80	633334	3500.01	DFT-s-OFDM PI/2 BPSK	1@0	3.69	13	PASS
78	30	80	633334	3500.01	DFT-s-OFDM QPSK	216@0	7.95	13	PASS
78	30	80	633334	3500.01	DFT-s-OFDM QPSK	1@0	6.49	13	PASS

B41_N78(80M)_DFT-s-OFDM_PI_2-BPSK_Outer_Full_Mid_CH

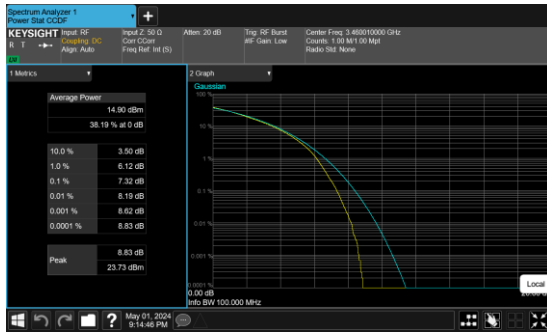

B41_N78(80M)_DFT-s-OFDM_PI_2-BPSK_Edge_1RB_Left_Mid_CH

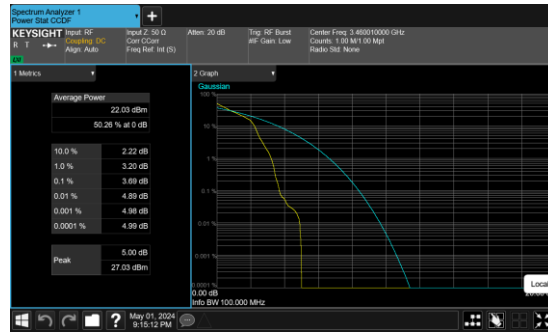

B41_N78(80M)_DFT-s-OFDM_QPSK_Outer_Full_Mid_CH



B41_N78(80M)_DFT-s-OFDM_QPSK_Edge_1RB_Left_Mid_CH

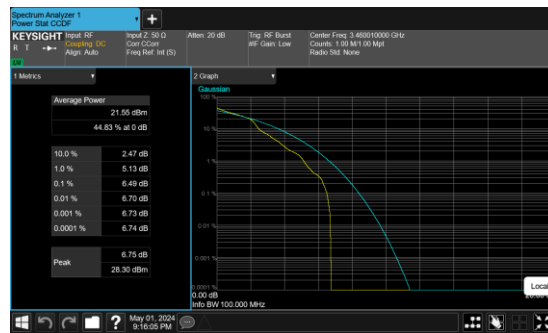

Occupied Bandwidth

NR Band	SCS (kHz)	Bandwidth (MHz)	Arfcn	Freq (MHz)	Modulation	RB	OBW (MHz)	26dB BW (MHz)
78	30	80	633334	3500.01	CP-OFDM QPSK	217@0	77.4	79.97
78	30	80	633334	3500.01	CP-OFDM 16 QAM	217@0	77.413	79.99
78	30	80	633334	3500.01	CP-OFDM 64 QAM	217@0	77.382	79.99
78	30	80	633334	3500.01	CP-OFDM 256 QAM	217@0	77.479	79.99

B41_N78(80M)_CP-OFDM_QPSK_Outer_Full_Mid_CH

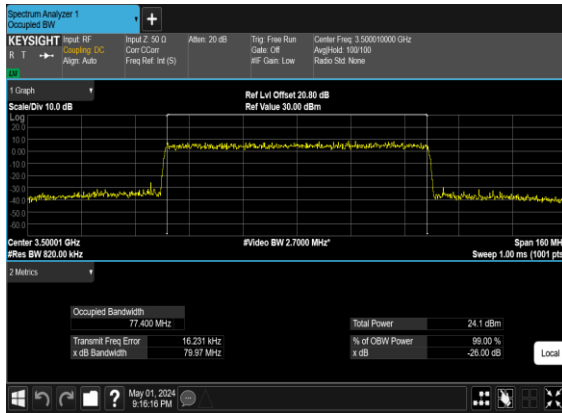

B41_N78(80M)_CP-OFDM_16 QAM_Outer_Full_Mid_CH

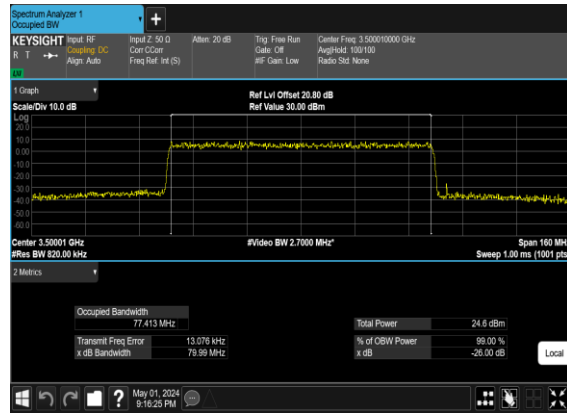

B41_N78(80M)_CP-OFDM_64 QAM_Outer_Full_Mid_CH

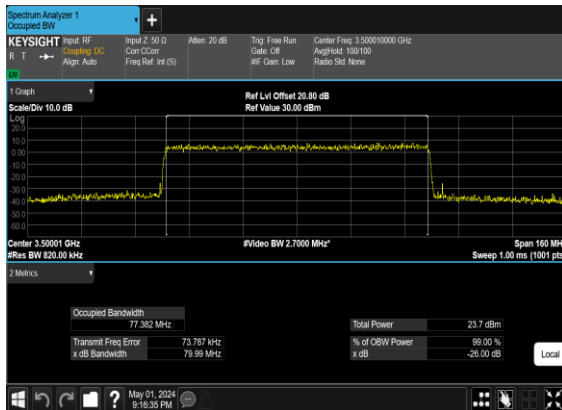

B41_N78(80M)_CP-OFDM_256 QAM_Outer_Full_Mid_CH

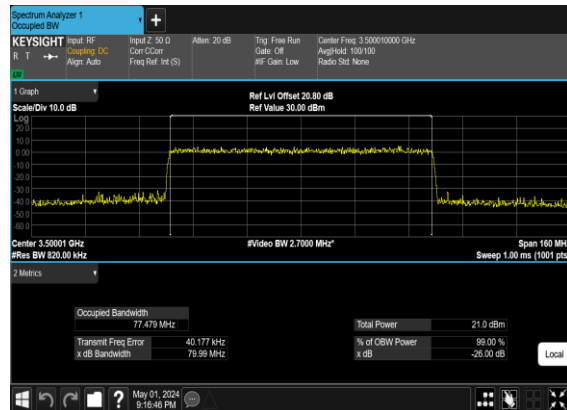

Conducted Spurious Emissions

NR Band	SCS (kHz)	Bandwidth (MHz)	Arfcn	Freq (MHz)	Modulation	RB	Result	Verdict
78	30	80	632668	3490.02	DFT-s-OFDM BPSK	1@0	see graph	---
78	30	80	632668	3490.02	DFT-s-OFDM BPSK	1@0	see graph	PASS
78	30	80	632668	3490.02	DFT-s-OFDM BPSK	1@0	see graph	PASS
78	30	80	632668	3490.02	DFT-s-OFDM QPSK	1@0	see graph	---
78	30	80	632668	3490.02	DFT-s-OFDM QPSK	1@0	see graph	PASS
78	30	80	632668	3490.02	DFT-s-OFDM QPSK	1@0	see graph	PASS
78	30	80	633334	3500.01	DFT-s-OFDM BPSK	1@0	see graph	---
78	30	80	633334	3500.01	DFT-s-OFDM BPSK	1@0	see graph	PASS
78	30	80	633334	3500.01	DFT-s-OFDM BPSK	1@0	see graph	PASS
78	30	80	633334	3500.01	DFT-s-OFDM QPSK	1@0	see graph	---
78	30	80	633334	3500.01	DFT-s-OFDM QPSK	1@0	see graph	PASS
78	30	80	633334	3500.01	DFT-s-OFDM QPSK	1@0	see graph	PASS
78	30	80	634000	3510.0	DFT-s-OFDM BPSK	1@0	see graph	---
78	30	80	634000	3510.0	DFT-s-OFDM BPSK	1@0	see graph	PASS
78	30	80	634000	3510.0	DFT-s-OFDM BPSK	1@0	see graph	PASS
78	30	80	634000	3510.0	DFT-s-OFDM QPSK	1@0	see graph	---
78	30	80	634000	3510.0	DFT-s-OFDM QPSK	1@0	see graph	PASS
78	30	80	634000	3510.0	DFT-s-OFDM QPSK	1@0	see graph	PASS