



FCC RF Test Report

APPLICANT : FCNT LLC.
EQUIPMENT : Mobile cellular phone
BRAND NAME : arrows We2
MODEL NAME : F-52E
FCC ID : 2BEPUFMP195
STANDARD : 47 CFR Part 2, 27 Subpart O (3700-3980MHz)
CLASSIFICATION : PCS Licensed Transmitter Held to Ear (PCE)
TEST DATE(S) : Jan. 25, 2024 ~ Apr. 03, 2024

We, Sporton International Inc. (KunShan), would like to declare that the tested sample has been evaluated in accordance with the procedures given in ANSI C63.26-2015 and shown compliance with the applicable technical standards.

The test results in this report apply exclusively to the tested model / sample. Without written approval of Sporton International Inc. (KunShan), the test report shall not be reproduced except in full.

Jason Jia

Approved by: Jason Jia



Sporton International Inc. (Kunshan)

**No. 1098, Pengxi North Road, Kunshan Economic Development Zone Jiangsu Province 215300
People's Republic of China**



TABLE OF CONTENTS

REVISION HISTORY... 3
SUMMARY OF TEST RESULT ... 4
1 GENERAL DESCRIPTION ... 5
1.1 Applicant ... 5
1.2 Manufacturer ... 5
1.3 Product Feature of Equipment Under Test ... 5
1.4 Product Specification of Equipment Under Test ... 5
1.5 Modification of EUT ... 5
1.6 Maximum EIRP and Emission Designator ... 6
1.7 Testing Location ... 6
1.8 Test Software ... 6
1.9 Applicable Standards ... 7
2 TEST CONFIGURATION OF EQUIPMENT UNDER TEST ... 8
2.1 Test Mode ... 8
2.2 Connection Diagram of Test System ... 9
2.3 Support Unit used in test configuration and system ... 9
2.4 Measurement Results Explanation Example ... 9
2.5 Frequency List of Low/Middle/High Channels ... 10
3 CONDUCTED TEST ITEMS ... 11
3.1 Measuring Instruments ... 11
3.2 Test Setup ... 11
3.3 Test Result of Conducted Test ... 11
3.4 Conducted Output Power and EIRP ... 12
3.5 Peak-to-Average Ratio ... 13
3.6 Occupied Bandwidth ... 14
3.7 Conducted Band Edge ... 15
3.8 Conducted Spurious Emission ... 16
3.9 Frequency Stability ... 17
4 RADIATED TEST ITEMS ... 18
4.1 Measuring Instruments ... 18
4.2 Test Setup ... 18
4.3 Test Result of Radiated Test ... 19
4.4 Radiated Spurious Emission ... 20
5 LIST OF MEASURING EQUIPMENT ... 21
6 MEASUREMENT UNCERTAINTY ... 22
APPENDIX A. TEST RESULTS OF CONDUCTED TEST
APPENDIX B. TEST RESULTS OF RADIATED TEST
APPENDIX C. TEST SETUP PHOTOGRAPHS



REVISION HISTORY

REPORT NO.	VERSION	DESCRIPTION	ISSUED DATE
FG3D0613-04D	Rev. 01	Initial issue of report	May 22, 2024



SUMMARY OF TEST RESULT

Report Section	FCC Rule	Description	Limit	Result	Remark
3.4	§2.1046	Conducted Output Power	Reporting Only	PASS	-
	§27.50(j)(3)	Equivalent Isotropic Radiated Power (5G NR n77, n78)	EIRP < 1Watt		
3.5	§27.50(j)(4)	Peak-to-Average Ratio	<13 dB	PASS	-
3.6	§2.1049	Occupied Bandwidth	Reporting Only	PASS	-
3.7	§2.1051 §27.53(l)(2)	Conducted Band Edge Measurement (5G NR n77, n78)	< 43+10log10(P[Watts])	PASS	-
3.8	§2.1051 §27.53(l)(2)	Conducted Spurious Emission (5G NR n77, n78)	< 43+10log10(P[Watts])	PASS	-
3.9	§27.54	Frequency Stability Temperature & Voltage	Within Authorized Band	PASS	-
4.4	§2.1053 §27.53(l)(2)	Radiated Spurious Emission (5G NR n77, n78)	< 43+10log ₁₀ (P[Watts])	PASS	Under limit 35.35 dB at 11100.00 MHz

Conformity Assessment Condition:

1. The test results (PASS/FAIL) with all measurement uncertainty excluded are presented against the regulation limits or in accordance with the requirements stipulated by the applicant/manufacturer who shall bear all the risks of non-compliance that may potentially occur if measurement uncertainty is taken into account.
2. The measurement uncertainty please refer to each test result in the section "Measurement Uncertainty"

Disclaimer:

The product specifications of the EUT presented in the test report that may affect the test assessments are declared by the manufacturer who shall take full responsibility for the authenticity.



1 General Description

1.1 Applicant

FCNT LLC.

Sanki Yamato Bldg. 3F, 7-10-1, Chuorinkan, Yamato-shi, Kanagawa, 242-0007, Japan

1.2 Manufacturer

FCNT LLC.

Sanki Yamato Bldg. 3F, 7-10-1, Chuorinkan, Yamato-shi, Kanagawa, 242-0007, Japan

1.3 Product Feature of Equipment Under Test

Product Feature	
Equipment	Mobile cellular phone
Brand Name	arrows We2
Model Name	F-52E
FCC ID	2BEPUFMP195
IMEI Code	Conducted : 354214220026404/354214220026412 Radiation : 354214220043508/354214220043516
HW Version	V4
SW Version	FAC_V006
EUT Stage	Identical Prototype

1.4 Product Specification of Equipment Under Test

Standards-related Product Specification	
Tx/Rx Frequency	5G NR n77: 3700 MHz ~ 3980 MHz 5G NR n78: 3700 MHz ~ 3800 MHz
SCS	30kHz
Bandwidth	n77: 20 / 40 / 100MHz n78: 20 / 40 / 80 / 100MHz
Antenna Gain	<Ant. 0> 5G NR n77/n78: -1.8 dBi
Type of Modulation	CP-OFDM: QPSK / 16QAM / 64QAM / 256QAM DFT-s-OFDM: PI/2 BPSK / QPSK / 16QAM / 64QAM / 256QAM

Remark:

1. 5G NR n77/n78 support NSA mode only.
2. The EN-DC mode support DC_41A_n77A and DC_41A_n78A.

1.5 Modification of EUT

No modifications are made to the EUT during all test items.



1.6 Maximum EIRP and Emission Designator

5G NR n77		PI/2 BPSK / QPSK		16QAM / 64QAM / 256QAM	
BW (MHz)	Frequency Range (MHz)	Maximum EIRP(W)	Emission Designator (99%OBW)	Maximum EIRP(W)	Emission Designator (99%OBW)
100	3750.00 ~ 3930.00	0.0274	97M3G7D	0.0269	97M3W7D

5G NR n78		PI/2 BPSK / QPSK		16QAM / 64QAM / 256QAM	
BW (MHz)	Frequency Range (MHz)	Maximum EIRP(W)	Emission Designator (99%OBW)	Maximum EIRP(W)	Emission Designator (99%OBW)
100	3750.00 ~ 3750.00	0.0273	97M3G7D	0.0264	97M3W7D

Note:

- 5G NR Band n77 overlaps the entire frequency range of Band n78, and n77 power > n78 power, therefore the conducted test results of n77 provided in this report cover n78 and 5G NR n78 supports BW 80MHz, it is tested in the report.
- All modulations have been tested, and only the worst test results of PSK & QAM are shown in the report.

1.7 Testing Location

Sporton International Inc. (Kunshan) is accredited to ISO/IEC 17025:2017 by American Association for Laboratory Accreditation with Certificate Number 5145.02.

Test Firm	Sporton International Inc. (Kunshan)		
Test Site Location	No. 1098, Pengxi North Road, Kunshan Economic Development Zone Jiangsu Province 215300 People's Republic of China TEL : +86-512-57900158		
Test Site No.	Sporton Site No.	FCC Designation No.	FCC Test Firm Registration No.
	03CH04-KS TH01-KS	CN1257	314309

1.8 Test Software

Item	Site	Manufacture	Name	Version
1.	TH01-KS	Tonscend	JS1120-3 test system China_210602	3.3.10
2.	03CH04-KS	AUDIX	E3	210616



1.9 Applicable Standards

According to the specifications of the manufacturer, the EUT must comply with the requirements of the following standards:

- ♦ 47 CFR Part 2, 27
- ♦ ANSI C63.26-2015
- ♦ FCC KDB 971168 D01 Power Meas License Digital Systems v03r01
- ♦ FCC KDB 412172 D01 Determining ERP and EIRP v01r01

Remark:

All test items were verified and recorded according to the standards and without any deviation during the test.



2 Test Configuration of Equipment Under Test

2.1 Test Mode

Antenna port conducted and radiated test items are performed according to KDB 971168 D01 Power Meas License Digital Systems v03r01 with maximum output power.

For radiated measurement, pre-scanned in three orthogonal panels, X, Y, Z. The worst cases (Z plane) were recorded in this report.

The device is investigated from 30MHz to 10 times of fundamental signal for radiated spurious emission test under different RB size/offset and modulations in exploratory test. Subsequently, only the worst case emissions are reported.

Orthogonal Planes of EUT	X Plane	Y Plane	Z Plane
			

Test Items	5G NR	Bandwidth (MHz)										Modulation					RB #			Test Channel				
		10	15	20	25	30	40	50	60	80	100	PI/2 BPSK	QPSK	16 QAM	64 QAM	256 QAM	1	Partial	Full	L	M	H		
Max. Output Power	n77	-	-	v	-	-	v	-	-	-	v	v	v	v	v	v	v	v	v	v	v	v	v	v
	n78	-	-	v	-	-	v	-	-	v	v	v	v	v	v	v	v	v	v	v	v	v	v	v
Peak-to-Average Ratio	n77	-	-	v	-	-	-	-	-	-	-	v	v	-	-	-	v	-	v	-	v	-	-	
	n78	-	-	-	-	-	-	-	v	-	-	v	v	-	-	-	v	-	v	-	v	-	-	
26dB and 99% Bandwidth	n77	-	-	v	-	-	v	-	-	-	v	-	v	v	v	-	-	v	-	v	-	-		
	n78	-	-	-	-	-	-	-	v	-	-	-	v	v	v	-	-	v	-	v	-	-		
Conducted Band Edge	n77	-	-	v	-	-	v	-	-	-	v	v	v	-	-	-	v	-	v	v	-	v		
	n78	-	-	-	-	-	-	-	v	-	-	v	v	-	-	-	v	-	v	v	-	v		
Conducted Spurious Emission	n77	-	-	v	-	-	v	-	-	-	v	v	v	-	-	-	v	-	-	v	v	v		
	n78	-	-	-	-	-	-	-	v	-	-	v	v	-	-	-	v	-	-	v	v	v		
Frequency Stability	n77	-	-	-	-	-	-	-	-	v	-	-	-	-	-	-	-	v	-	-	v	-		
	n78	-	-	-	-	-	-	-	v	-	-	-	-	-	-	-	-	v	-	-	v	-		
E.I.R.P	n77	-	-	v	-	-	v	-	-	-	v	v	v	v	v	v	v	v	v	v	v	v		
	n78	-	-	v	-	-	v	-	-	v	v	v	v	v	v	v	v	v	v	v	v	v		
Radiated Spurious Emission	n77	Worst Case																			-	-	v	
	n78	Worst Case																			-	-	v	
Note	<ol style="list-style-type: none"> The mark "v" means that this configuration is chosen for testing The mark "-" means that this bandwidth is not supported. The device is investigated from 30MHz to 10 times of fundamental signal for radiated spurious emission test under different RB size/offset and modulations in exploratory test. Subsequently, only the worst case emissions are reported. Frequency Stability : Normal Voltage = 3.91V; Low Voltage =3.40V; High Voltage =4.48V. 																							

2.2 Connection Diagram of Test System

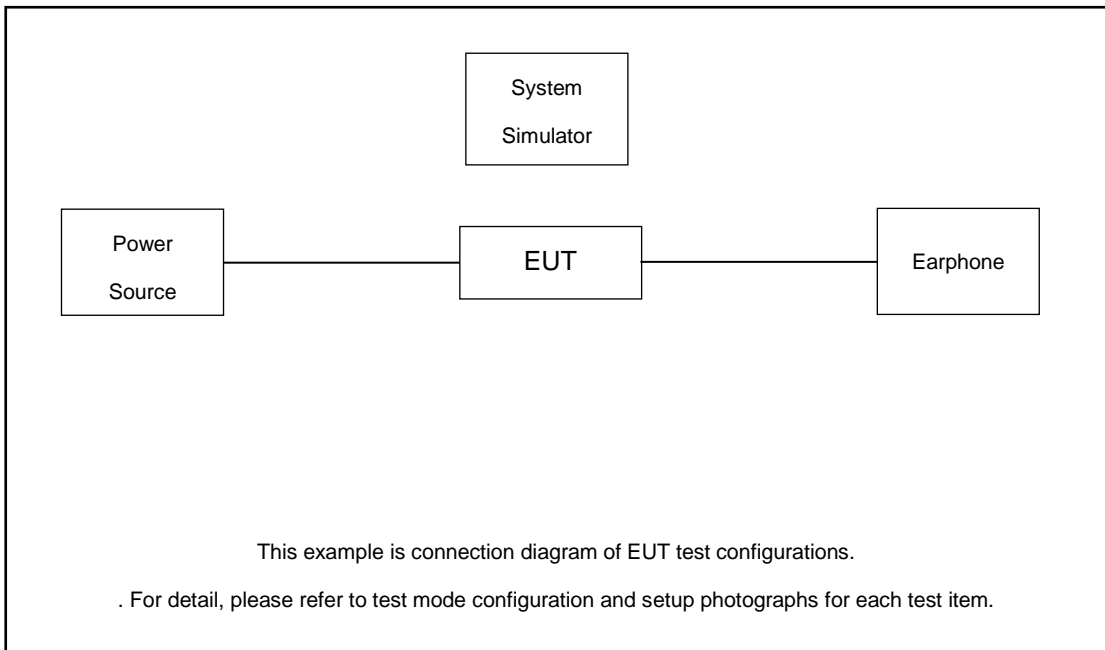

2.3 Support Unit used in test configuration and system

Item	Equipment	Trade Name	Model No.	FCC ID	Data Cable	Power Cord
1.	DC Power Supply	GW	GPS-3030D	N/A	N/A	Unshielded, 1.8 m
2.	LTE Base Station	Anritsu	MT8821C	N/A	N/A	Unshielded, 1.8 m
3.	NR Base Station	Anritsu	MT8000A	N/A	N/A	Unshielded, 1.8 m

2.4 Measurement Results Explanation Example

For all conducted test items:

The offset level is set in the spectrum analyzer to compensate the RF cable loss and attenuator factor between EUT conducted output port and spectrum analyzer. With the offset compensation, the spectrum analyzer reading level is exactly the EUT RF output level.

The spectrum analyzer offset is derived from RF cable loss and attenuator factor.

$$\text{Offset} = \text{RF cable loss} + \text{attenuator factor}.$$

Following shows an offset computation example with cable loss 6.5 dB and 20dB attenuator.

Example :

$$\begin{aligned} \text{Offset(dB)} &= \text{RF cable loss(dB)} + \text{attenuator factor(dB)}. \\ &= 5.2 + 10 = 26.5 \text{ (dB)} \end{aligned}$$



2.5 Frequency List of Low/Middle/High Channels

5G n77 (30kHz) Channel and Frequency List				
BW [MHz]	Channel/Frequency(MHz)	Lowest	Middle	Highest
100	Channel	650000	656000	662000
	Frequency	3750	3840	3930
40	Channel	648000	656000	664000
	Frequency	3720	3840	3960
20	Channel	647334	656000	664666
	Frequency	3710.01	3840	3969.99

5G n78(30kHz) Channel and Frequency List				
BW [MHz]	Channel/Frequency(MHz)	Lowest	Middle	Highest
100	Channel	650000		
	Frequency	3750		
80	Channel	649334	650000	650666
	Frequency	3740.01	3750	3759.99
40	Channel	648000	650000	652000
	Frequency	3720	3750	3780
20	Channel	647334	650000	652666
	Frequency	3710.01	3750	3789.99

3 Conducted Test Items

3.1 Measuring Instruments

See list of measuring instruments of this test report.

3.2 Test Setup

3.2.1 Conducted Output Power



3.2.2 Peak-to-Average Ratio, Occupied Bandwidth, Conducted Band-Edge and Conducted Spurious Emission

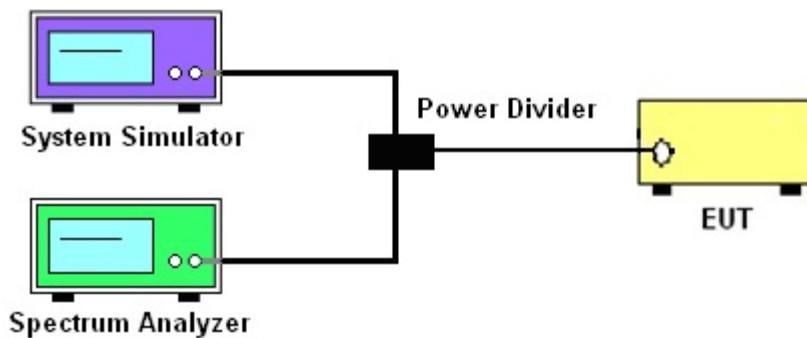

3.2.3 Frequency Stability

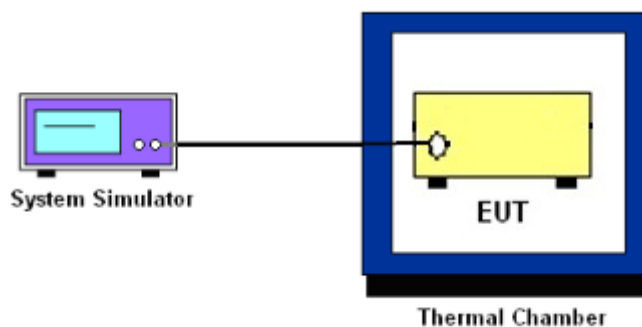

3.3 Test Result of Conducted Test

Please refer to Appendix A.



3.4 Conducted Output Power and EIRP

3.4.1 Description of the Conducted Output Power Measurement and EIRP Measurement

A system simulator was used to establish communication with the EUT. Its parameters were set to force the EUT transmitting at maximum output power. The measured power in the radio frequency on the transmitter output terminals shall be reported.

The EIRP of mobile transmitters must not exceed 1 Watts for 5G NR n77, n78.

According to KDB 412172 D01 Power Approach,

$EIRP = P_T + G_T - L_C$, $ERP = EIRP - 2.15$, where

P_T = transmitter output power in dBm

G_T = gain of the transmitting antenna in dBi

L_C = signal attenuation in the connecting cable between the transmitter and antenna in dB

3.4.2 Test Procedures

1. The testing follows ANSI C63.26 Section 5.2
2. The transmitter output port was connected to the system simulator.
3. Set EUT at maximum power through the system simulator.
4. Select lowest, middle, and highest channels for each band and different modulation.
5. Measure and record the power level from the system simulator.



3.5 Peak-to-Average Ratio

3.5.1 Description of the PAR Measurement

Power Complementary Cumulative Distribution Function (CCDF) curves provide a means for characterizing the power peaks of a digitally modulated signal on a statistical basis. A CCDF curve depicts the probability of the peak signal amplitude exceeding the average power level. Most contemporary measurement instrumentation include the capability to produce CCDF curves for an input signal provided that the instrument's resolution bandwidth can be set wide enough to accommodate the entire input signal bandwidth. In measuring transmissions in this band using an average power technique, the peak-to-average ratio (PAR) of the transmission may not exceed 13 dB.

3.5.2 Test Procedures

1. The testing follows ANSI C63.26 Section 5.2.3.4 (CCDF).
2. The EUT was connected to spectrum and system simulator via a power divider.
3. Set the CCDF (Complementary Cumulative Distribution Function) option in spectrum analyzer.
4. The highest RF powers were measured and recorded the maximum PAPR level associated with a probability of 0.1 %.
5. Record the deviation as Peak to Average Ratio.



3.6 Occupied Bandwidth

3.6.1 Description of Occupied Bandwidth Measurement

The occupied bandwidth is the width of a frequency band such that, below the lower and above the upper frequency limits, the mean powers emitted are each equal to a specified percentage 0.5% of the total mean transmitted power.

The 26 dB emission bandwidth is defined as the frequency range between two points, one above and one below the carrier frequency, at which the spectral density of the emission is attenuated 26 dB below the maximum in-band spectral density of the modulated signal. Spectral density (power per unit bandwidth) is to be measured with a detector of resolution bandwidth equal to approximately 1.0% of the emission bandwidth.

3.6.2 Test Procedures

1. The testing follows ANSI C63.26 Section 5.4
2. The EUT was connected to spectrum analyzer and system simulator via a power divider.
3. The spectrum analyzer center frequency is set to the nominal EUT channel center frequency. The span range for the spectrum analyzer shall be between two and five times the anticipated OBW.
4. The nominal resolution bandwidth (RBW) shall be in the range of 1 to 5 % of the anticipated OBW, and the VBW shall be at least 3 times the RBW.
5. Set the detection mode to peak, and the trace mode to max hold.
6. Determine the reference value: Set the EUT to transmit a modulated signal. Allow the trace to stabilize. Set the spectrum analyzer marker to the highest level of the displayed trace.
(this is the reference value)
7. Determine the “-26 dB down amplitude” as equal to (Reference Value – X).
8. Place two markers, one at the lowest and the other at the highest frequency of the envelope of the spectral display such that each marker is at or slightly below the “-X dB down amplitude” determined in step 6. If a marker is below this “-X dB down amplitude” value it shall be placed as close as possible to this value. The OBW is the positive frequency difference between the two markers.
9. Use the 99 % power bandwidth function of the spectrum analyzer and report the measured bandwidth.



3.7 Conducted Band Edge

3.7.1 Description of Conducted Band Edge Measurement

27.53(l)(2)

For mobile operations in the 3700-3980 MHz band, the conducted power of any emission outside the licensee's authorized bandwidth shall not exceed -13 dBm/MHz. Compliance with this paragraph is based on the use of measurement instrumentation employing a resolution bandwidth of 1 megahertz or greater. However, in the 1 megahertz bands immediately outside and adjacent to the licensee's frequency block, the minimum resolution bandwidth for the measurement shall be either one percent of the emission bandwidth of the fundamental emission of the transmitter or 350 kHz. In the bands between 1 and 5 MHz removed from the licensee's frequency block, the minimum resolution bandwidth for the measurement shall be 500 kHz.

3.7.2 Test Procedures

1. The testing follows ANSI C63.26 section 5.7
2. The EUT was connected to spectrum analyzer and system simulator via a power divider.
3. The band edges of low and high channels for the highest RF powers were measured.
4. Set RBW \geq 1% EBW in the 1MHz band immediately outside and adjacent to the band edge.
5. Beyond the 1 MHz band from the band edge, RBW=1MHz was used or a narrower RBW was used (generally limited to no less than 1% of the OBW) and the measured power was integrated over the full required measurement bandwidth.
6. Set spectrum analyzer with RMS detector.
7. The RF fundamental frequency should be excluded against the limit line in the operating frequency band.
8. Checked that all the results comply with the emission limit line.

Example:

$$\begin{aligned} & \text{The limit line is derived from } 43 + 10\log(P)\text{dB below the transmitter power } P(\text{Watts}) \\ & = P(\text{W}) - [43 + 10\log(P)] \text{ (dB)} \\ & = [30 + 10\log(P)] \text{ (dBm)} - [43 + 10\log(P)] \text{ (dB)} = -13\text{dBm.} \end{aligned}$$

9. When using the integration method, the starting frequency of the integration shall be centered at one-half of the RBW away from the band edge.



3.8 Conducted Spurious Emission

3.8.1 Description of Conducted Spurious Emission Measurement

The power of any emission outside of the authorized operating frequency ranges must be lower than the transmitter power (P) by a factor of at least $43 + 10 \log (P)$ dB.

It is measured by means of a calibrated spectrum analyzer and scanned from 30 MHz up to a frequency including its 10th harmonic.

3.8.2 Test Procedures

1. The testing follows ANSI C63.26 section 5.7
2. The EUT was connected to spectrum analyzer and system simulator via a power divider.
3. The RF output of EUT was connected to the spectrum analyzer by RF cable and attenuator. The path loss was compensated to the results for each measurement.
4. The middle channel for the highest RF power within the transmitting frequency was measured.
5. The conducted spurious emission for the whole frequency range was taken.
6. Make the measurement with the spectrum analyzer's RBW = 1MHz, VBW = 3MHz.
7. Set spectrum analyzer with RMS detector.
8. Taking the record of maximum spurious emission.
9. The RF fundamental frequency should be excluded against the limit line in the operating frequency band.
10. The limit line is derived from $43 + 10\log(P)$ dB below the transmitter power P(Watts)
= $P(W) - [43 + 10\log(P)]$ (dB)
= $[30 + 10\log(P)]$ (dBm) - $[43 + 10\log(P)]$ (dB)
= -13dBm.



3.9 Frequency Stability

3.9.1 Description of Frequency Stability Measurement

The frequency stability shall be measured by variation of ambient temperature and variation of primary supply voltage to ensure that the fundamental emission stays within the authorized frequency block. The frequency stability of the transmitter shall be maintained within $\pm 0.00025\%$ ($\pm 2.5\text{ppm}$) of the center frequency.

3.9.2 Test Procedures for Temperature Variation

1. The testing follows ANSI C63.26 section 5.6.4
2. The EUT was set up in the thermal chamber and connected with the system simulator.
3. With power OFF, the temperature was decreased to -30°C and the EUT was stabilized before testing. Power was applied and the maximum change in frequency was recorded within one minute.
4. With power OFF, the temperature was raised in 10°C step up to 50°C . The EUT was stabilized at each step for at least half an hour. Power was applied and the maximum frequency change was recorded within one minute.

3.9.3 Test Procedures for Voltage Variation

1. The testing follows ANSI C63.26 section 5.6.5
2. The EUT was placed in a temperature chamber at $20\pm 5^{\circ}\text{C}$ and connected with the system simulator.
3. The power supply voltage to the EUT was varied from 85% to 115% of the nominal value for other than hand carried battery equipment.
4. For hand carried, battery powered equipment, reduce the primary ac or dc supply voltage to the battery operating end point, which shall be specified by the manufacturer.
5. The variation in frequency was measured for the worst case.

4 Radiated Test Items

4.1 Measuring Instruments

See list of measuring instruments of this test report.

4.2 Test Setup

4.2.1 For radiated test below 30MHz

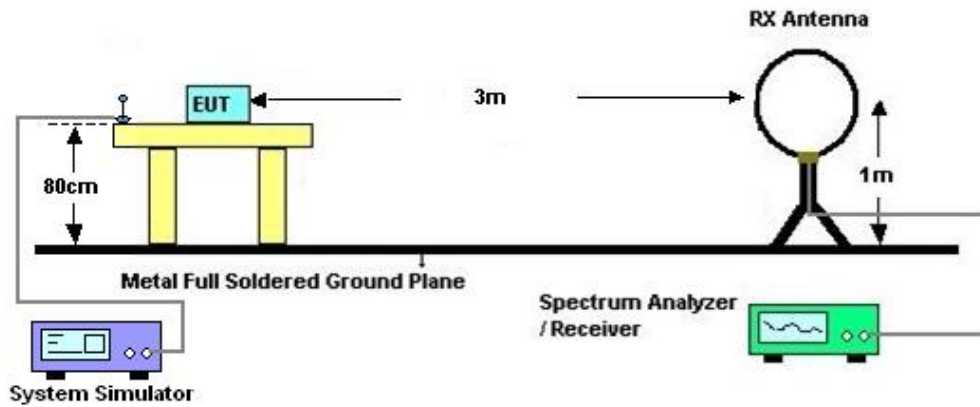

4.2.2 For radiated test from 30MHz to 1GHz

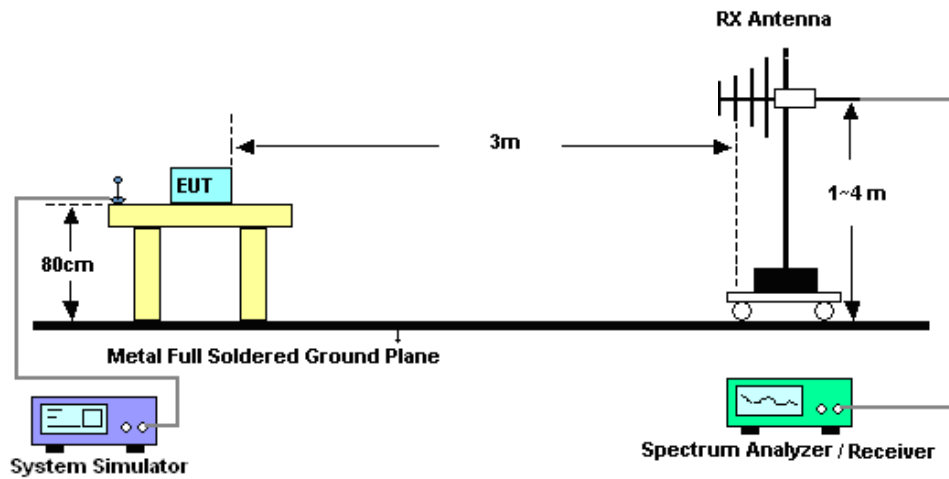

4.2.3 For radiated test above 1GHz

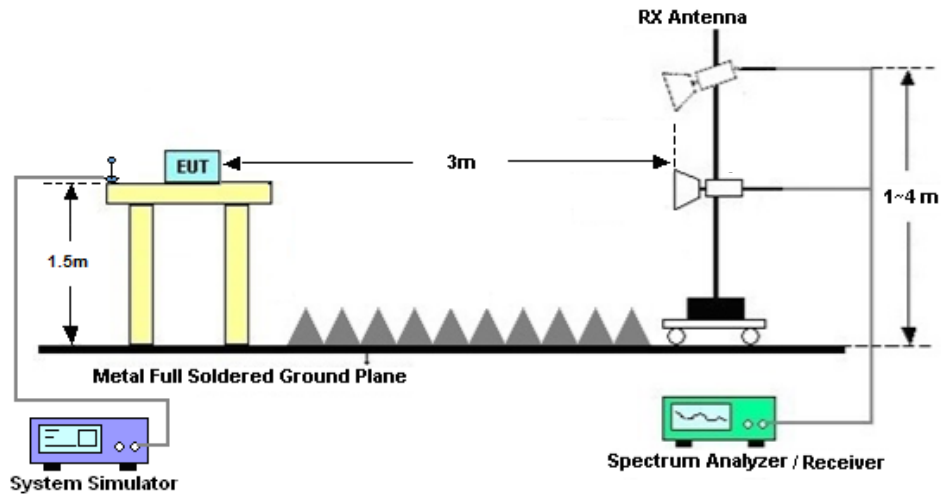

4.3 Test Result of Radiated Test

The low frequency, which started from 9 kHz to 30MHz, was pre-scanned and the result which was 20dB lower than the limit line was not reported.

Please refer to Appendix B.



4.4 Radiated Spurious Emission

4.4.1 Description of Radiated Spurious Emission

The radiated spurious emission was measured by substitution method according to ANSI C63.26. The power of any emission outside of the authorized operating frequency ranges must be attenuated below the transmitter power (P) by a factor of at least $43 + 10 \log (P)$ dB.

The spectrum is scanned from 30 MHz up to a frequency including its 10th harmonic.

4.4.2 Test Procedures

1. The testing follows ANSI C63.26 Section 5.5
2. The EUT was placed on a turntable with 0.8 meter height for frequency below 1GHz and 1.5 meter height for frequency above 1GHz respectively above ground.
3. The EUT was set 3 meters from the receiving antenna mounted on the antenna tower.
4. The table was rotated 360 degrees to determine the position of the highest spurious emission.
5. The height of the receiving antenna is varied between 1m to 4m to search the maximum spurious emission for both horizontal and vertical polarizations.
6. During the measurement, the system simulator parameters were set to force the EUT transmitting at maximum output power.
7. Make the measurement with the spectrum analyzer's RBW = 1MHz, VBW = 3MHz, taking the record of maximum spurious emission.
8. A horn antenna was substituted in place of the EUT and was driven by a signal generator.
9. Tune the output power of signal generator to the same emission level with EUT maximum spurious emission.
10. $EIRP (dBm) = S.G. Power - Tx Cable Loss + Tx Antenna Gain$
11. $ERP (dBm) = EIRP - 2.15$
12. The RF fundamental frequency should be excluded against the limit line in the operating frequency band.

The limit line is derived from $43 + 10\log(P)$ dB below the transmitter power P(Watts)
= $P(W) - [43 + 10\log(P)] (dB)$
= $[30 + 10\log(P)] (dBm) - [43 + 10\log(P)] (dB)$
= -13dBm.



5 List of Measuring Equipment

Instrument	Manufacturer	Model No.	Serial No.	Characteristics	Calibration Date	Test Date	Due Date	Remark
Spectrum Analyzer	R&S	FSV40	101040	10Hz~40GHz	Oct. 11, 2023	Jan. 25, 2024~Feb. 29, 2024	Oct. 10, 2024	Conducted (TH01-KS)
Power divider	STI	STI08-0055	-	0.5~40GHz	NCR	Jan. 25, 2024~Feb. 29, 2024	NCR	Conducted (TH01-KS)
Temperature & humidity chamber	Hongzhan	LP-150U	H2014011440	-40~+150°C 20%~95%RH	Jul. 06, 2023	Jan. 25, 2024~Feb. 29, 2024	Jul. 05, 2024	Conducted (TH01-KS)
EXA Spectrum Analyzer	Keysight	N9010B	MY57471079	10Hz-44G,MAX 30dB	Oct. 10, 2023	Apr. 03, 2024	Oct. 09, 2024	Radiation (03CH04-KS)
Loop Antenna	R&S	HFH2-Z2E	101125	9kHz~30MHz	Sep. 11 2023	Apr. 03, 2024	Sep. 10, 2024	Radiation (03CH04-KS)
Bilog Antenna	TeseQ	CBL6111D	49922	30MHz-1GHz	Apr. 09, 2023	Apr. 03, 2024	Apr. 08, 2024	Radiation (03CH04-KS)
Double Ridge Horn Antenna	ETS-Lindgren	3117	00251694	1GHz~18GHz	Jul. 12, 2023	Apr. 03, 2024	Jul. 11, 2024	Radiation (03CH04-KS)
SHF-EHF Horn	Com-power	AH-840	101070	18GHz~40GHz	Jan. 05, 2024	Apr. 03, 2024	Jan. 04, 2025	Radiation (03CH04-KS)
Amplifier	SONOMA	310N	380827	9KHz-1GHz	Jul. 06, 2023	Apr. 03, 2024	Jul. 05, 2024	Radiation (03CH04-KS)
Amplifier	MITEQ	EM18G40G GA	060728	18~40GHz	Jan. 05, 2024	Apr. 03, 2024	Jan. 04, 2025	Radiation (03CH04-KS)
high gain Amplifier	EM	EM01G18G A	060840	1Ghz-18Ghz	Oct. 10, 2023	Apr. 03, 2024	Oct. 09, 2024	Radiation (03CH04-KS)
Amplifier	Agilent	8449B	3008A02370	1Ghz-18Ghz	Oct. 10, 2023	Apr. 03, 2024	Oct. 09, 2024	Radiation (03CH04-KS)
AC Power Source	Chroma	61601	F104090004	N/A	NCR	Apr. 03, 2024	NCR	Radiation (03CH04-KS)
Turn Table	ChamPro	EM 1000-T	060762-T	0~360 degree	NCR	Apr. 03, 2024	NCR	Radiation (03CH04-KS)
Antenna Mast	ChamPro	EM 1000-A	060762-A	1 m~4 m	NCR	Apr. 03, 2024	NCR	Radiation (03CH04-KS)

NCR: No Calibration Required



6 Measurement Uncertainty

The measurement uncertainties shown below were calculated in accordance with the requirements of ANSI 63.26-2015. All the measurement uncertainty value were shown with a coverage K=2 to indicate 95% level of confidence. The measurement data show herein meets or exceeds the CISPR measurement uncertainty values specified in CISPR 16-4-2 and can be compared directly to specified limit to determine compliance.

Uncertainty of Conducted Measurement

Conducted Spurious Emission & Bandedge	±2.26 dB
Occupied Channel Bandwidth	±0.1%
Conducted Power	±0.46 dB
Peak to Average Ratio	±0.46 dB
Frequency Stability	±0.4 Hz

Uncertainty of Radiated Emission Measurement (30 MHz ~ 1000 MHz)

Measuring Uncertainty for a Level of Confidence of 95% (U = 2Uc(y))	3.82 dB
---	---------

Uncertainty of Radiated Emission Measurement (1 GHz ~ 18 GHz)

Measuring Uncertainty for a Level of Confidence of 95% (U = 2Uc(y))	3.56 dB
---	---------

Uncertainty of Radiated Emission Measurement (18 GHz ~ 40 GHz)

Measuring Uncertainty for a Level of Confidence of 95% (U = 2Uc(y))	3.54 dB
---	---------

----- THE END -----



Appendix A. Test Results of Conducted Test

Test Engineer :	Simle Wang	Temperature :	22~23°C
		Relative Humidity :	40~42%

Conducted Output Power(Average power) and EIRP

5G NR n77:

BW [MHz]	Modulation	RB Size	RB Offset	Power Low Ch. / Freq.	Power Middle Ch. / Freq.	Power High Ch. / Freq.	EIRP (W)		
							L	M	H
Channel				650000	656000	662000	L	M	H
Frequency (MHz)				3750	3840	3930			
100	PI/2 BPSK	1	1	16.03	16.02	16.08	0.0265	0.0264	0.0268
100	PI/2 BPSK	1	137	16.03	16.03	16.00	0.0265	0.0265	0.0263
100	PI/2 BPSK	1	271	15.99	16.03	16.08	0.0262	0.0265	0.0268
100	PI/2 BPSK	135	0	16.02	16.13	16.06	0.0264	0.0271	0.0267
100	PI/2 BPSK	135	69	16.04	16.10	15.89	0.0265	0.0269	0.0256
100	PI/2 BPSK	135	138	15.83	16.02	15.92	0.0253	0.0264	0.0258
100	PI/2 BPSK	270	0	15.80	15.97	16.06	0.0251	0.0261	0.0267
100	QPSK	1	1	15.98	16.18	16.05	0.0262	0.0274	0.0266
100	QPSK	1	137	15.82	16.16	15.96	0.0252	0.0273	0.0261
100	QPSK	1	271	15.97	16.09	15.96	0.0261	0.0269	0.0261
100	QPSK	135	0	16.00	16.01	15.89	0.0263	0.0264	0.0256
100	QPSK	135	69	15.97	16.05	16.02	0.0261	0.0266	0.0264
100	QPSK	135	138	15.96	16.03	16.03	0.0261	0.0265	0.0265
100	QPSK	270	0	15.89	16.00	15.93	0.0256	0.0263	0.0259
100	16QAM	1	1	15.82	16.10	15.95	0.0252	0.0269	0.0260
100	64QAM	1	1	15.98	16.07	15.89	0.0262	0.0267	0.0256
100	256QAM	1	1	15.84	15.96	16.00	0.0254	0.0261	0.0263
Channel				648000	656000	664000	L	M	H
Frequency (MHz)				3720	3840	3960			
40	QPSK	1	1	15.77	15.85	15.82	0.0249	0.0254	0.0252
Channel				647334	656000	664666	L	M	H
Frequency (MHz)				3710.01	3840	3969.99			
20	QPSK	1	1	15.75	15.84	15.80	0.0248	0.0254	0.0251



5G NR n78:

BW [MHz]	Modulation	RB Size	RB Offset	Power Low Ch. / Freq.	Power Middle Ch. / Freq.	Power High Ch. / Freq.	EIRP (W)						
Channel				650000	650000	650000	L	M	H				
Frequency (MHz)				3750	3750	3750							
100	PI/2 BPSK	1	1	/	16.05	/	/	0.0266	/				
100	PI/2 BPSK	1	137		15.94			0.0259					
100	PI/2 BPSK	1	271		16.03			0.0265					
100	PI/2 BPSK	135	0		16.13			0.0271					
100	PI/2 BPSK	135	69		15.98			0.0262					
100	PI/2 BPSK	135	138		15.97			0.0261					
100	PI/2 BPSK	270	0		16.12			0.0270					
100	QPSK	1	1		16.16			0.0273					
100	QPSK	1	137		16.00			0.0263					
100	QPSK	1	271		16.15			0.0272					
100	QPSK	135	0		16.14			0.0272					
100	QPSK	135	69		16.07			0.0267					
100	QPSK	135	138		15.98			0.0262					
100	QPSK	270	0		16.01			0.0264					
100	16QAM	1	1		16.02			0.0264					
100	64QAM	1	1		16.00			0.0263					
100	256QAM	1	1		15.95			0.0260					
Channel					649334			650000		650666	L	M	H
Frequency (MHz)					3740.01			3750		3759.99			
80	QPSK	1	1	15.76	15.83	15.81	0.0249	0.0253	0.0252				
Channel				648000	650000	652000	L	M	H				
Frequency (MHz)				3720	3750	3780							
40	QPSK	1	1	15.91	15.91	15.78	0.0258	0.0258	0.0250				
Channel				647334	650000	652666	L	M	H				
Frequency (MHz)				3710.01	3750	3789.99							
20	QPSK	1	1	15.77	15.74	15.83	0.0249	0.0248	0.0253				

FR1 N77 (ANT0)

Frequency Stability

NR Band	SCS (kHz)	Bandwidth (MHz)	Arfcn	Freq (MHz)	Modulation	RB	Deviation (ppm)	Verdict	Environment
77	30	100	656000	3840.0	DFT-s-OFDM QPSK	270@0	0.0028	PASS	NV
77	30	100	656000	3840.0	DFT-s-OFDM QPSK	270@0	0.0015	PASS	LV
77	30	100	656000	3840.0	DFT-s-OFDM QPSK	270@0	-0.0017	PASS	HV
77	30	100	656000	3840.0	DFT-s-OFDM QPSK	270@0	0.0013	PASS	-30°C
77	30	100	656000	3840.0	DFT-s-OFDM QPSK	270@0	0.0015	PASS	-20°C
77	30	100	656000	3840.0	DFT-s-OFDM QPSK	270@0	0.0027	PASS	-10°C
77	30	100	656000	3840.0	DFT-s-OFDM QPSK	270@0	-0.0032	PASS	0°C
77	30	100	656000	3840.0	DFT-s-OFDM QPSK	270@0	0.0031	PASS	10°C
77	30	100	656000	3840.0	DFT-s-OFDM QPSK	270@0	0.0024	PASS	20°C
77	30	100	656000	3840.0	DFT-s-OFDM QPSK	270@0	-0.0023	PASS	30°C
77	30	100	656000	3840.0	DFT-s-OFDM QPSK	270@0	0.0029	PASS	40°C
77	30	100	656000	3840.0	DFT-s-OFDM QPSK	270@0	0.0014	PASS	50°C

Peak to Average Ratio

NR Band	SCS (kHz)	Bandwidth (MHz)	Arfcn	Freq (MHz)	Modulation	RB	Result (dB)	Limit (dB)	Verdict
77	30	20	656000	3840.0	DFT-s-OFDM PI/2 BPSK	50@0	7.23	13	PASS
77	30	20	656000	3840.0	DFT-s-OFDM PI/2 BPSK	1@0	6.98	13	PASS
77	30	20	656000	3840.0	DFT-s-OFDM QPSK	50@0	8.4	13	PASS
77	30	20	656000	3840.0	DFT-s-OFDM QPSK	1@0	8.58	13	PASS

N77(20M)_DFT-s-OFDM_PI_2-BPSK_Outer_Full_Mid_CH

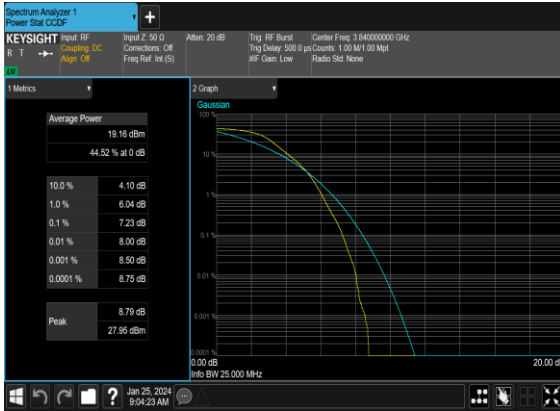

N77(20M)_DFT-s-OFDM_PI_2-BPSK_Edge_1RB_Left_Mid_CH



N77(20M)_DFT-s-OFDM_QPSK_Outer_Full_Mid_CH



N77(20M)_DFT-s-OFDM_QPSK_Edge_1RB_Left_Mid_CH

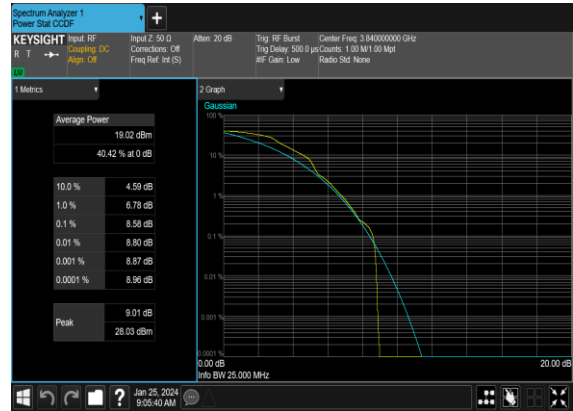

Occupied Bandwidth

NR Band	SCS (kHz)	Bandwidth (MHz)	Arfcn	Freq (MHz)	Modulation	RB	OBW (MHz)	26dB BW (MHz)
77	30	20	656000	3840.0	CP-OFDM QPSK	51@0	18.138	19.59
77	30	20	656000	3840.0	CP-OFDM 16 QAM	51@0	18.255	19.3
77	30	20	656000	3840.0	CP-OFDM 64 QAM	51@0	18.158	19.0
77	30	20	656000	3840.0	CP-OFDM 256 QAM	51@0	18.162	19.09
77	30	40	656000	3840.0	CP-OFDM QPSK	106@0	37.873	39.18
77	30	40	656000	3840.0	CP-OFDM 16 QAM	106@0	37.711	39.1
77	30	40	656000	3840.0	CP-OFDM 64 QAM	106@0	37.841	39.21
77	30	40	656000	3840.0	CP-OFDM 256 QAM	106@0	37.773	39.39
77	30	100	656000	3840.0	CP-OFDM QPSK	273@0	97.315	100.6
77	30	100	656000	3840.0	CP-OFDM 16 QAM	273@0	97.338	100.5
77	30	100	656000	3840.0	CP-OFDM 64 QAM	273@0	97.322	100.4
77	30	100	656000	3840.0	CP-OFDM 256 QAM	273@0	97.33	100.5

N77(20M)_CP-OFDM_QPSK_Outer_Full_Mid_CH

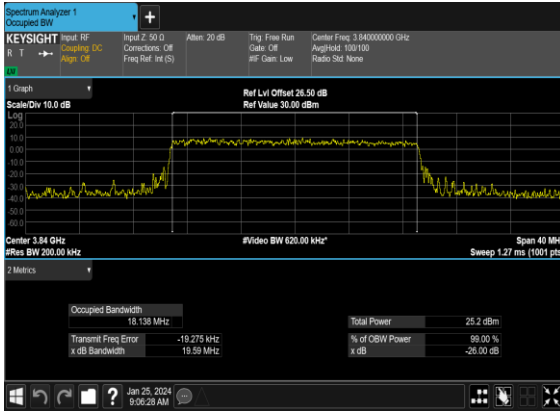

N77(20M)_CP-OFDM_16 QAM_Outer_Full_Mid_CH

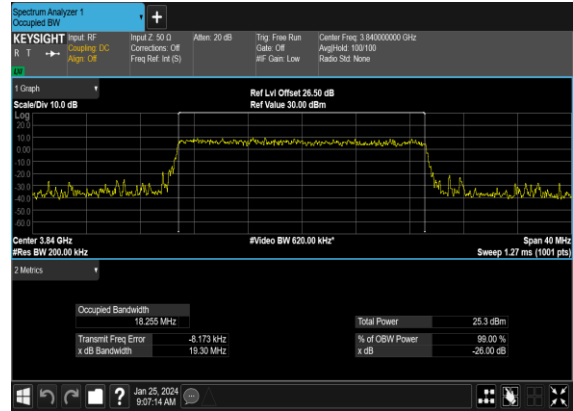

N77(20M)_CP-OFDM_64 QAM_Outer_Full_Mid_CH

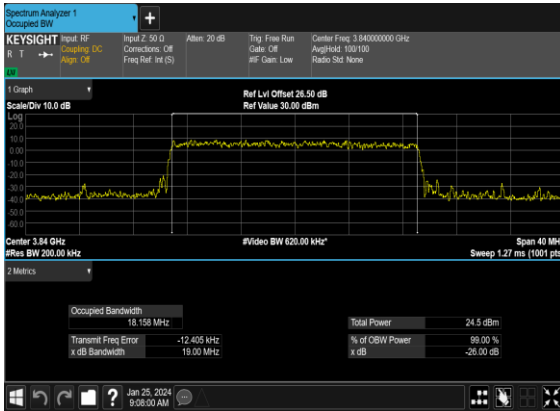

N77(20M)_CP-OFDM_256 QAM_Outer_Full_Mid_CH

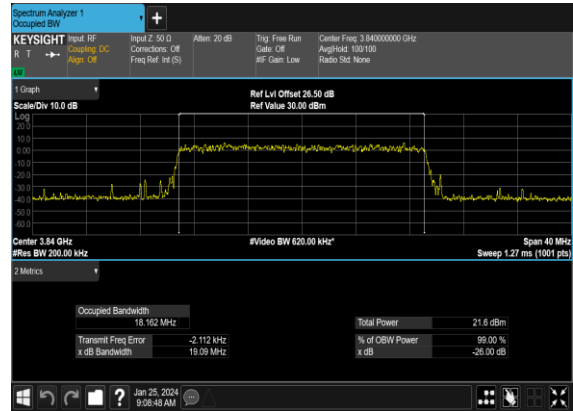

N77(40M)_CP-OFDM_QPSK_Outer_Full_Mid_CH

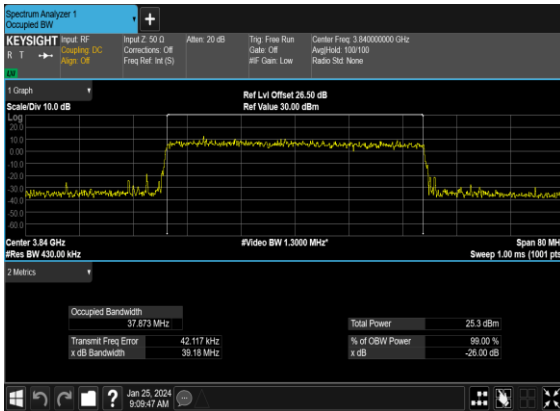

N77(40M)_CP-OFDM_16 QAM_Outer_Full_Mid_CH

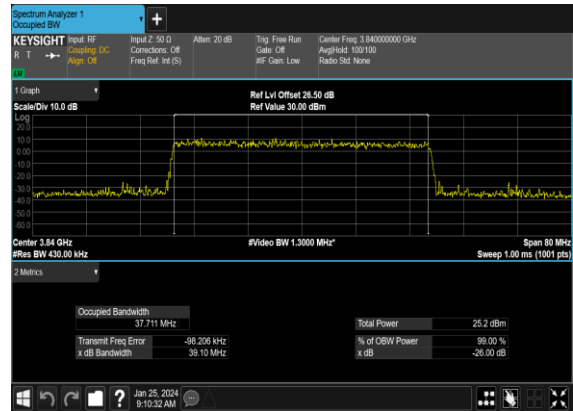

N77(40M)_CP-OFDM_64 QAM_Outer_Full_Mid_CH

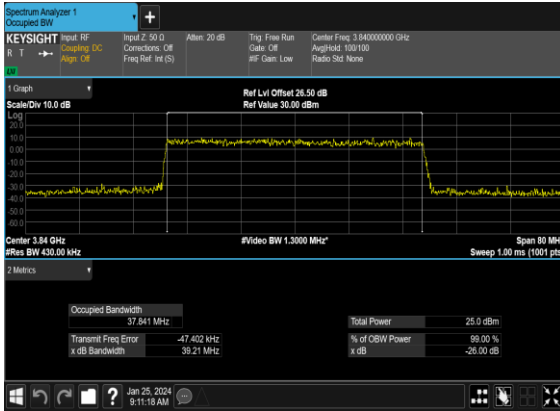

N77(40M)_CP-OFDM_256 QAM_Outer_Full_Mid_CH

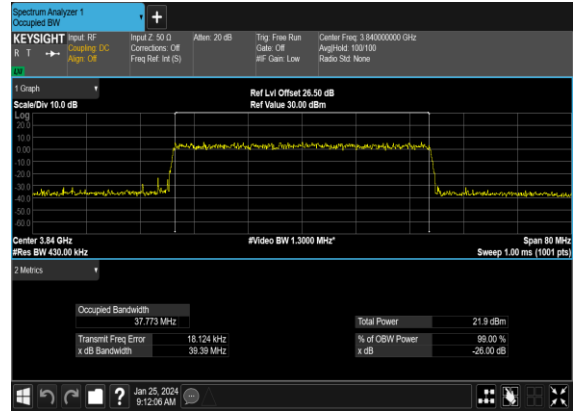

N77(100M)_CP- OFDM_QPSK_Outer_Full_Mid_CH

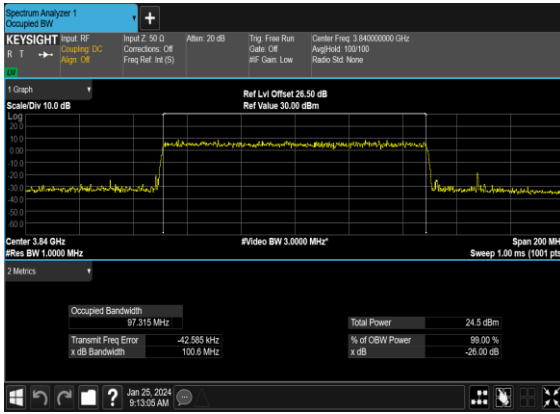

N77(100M)_CP-OFDM_16 QAM_Outer_Full_Mid_CH

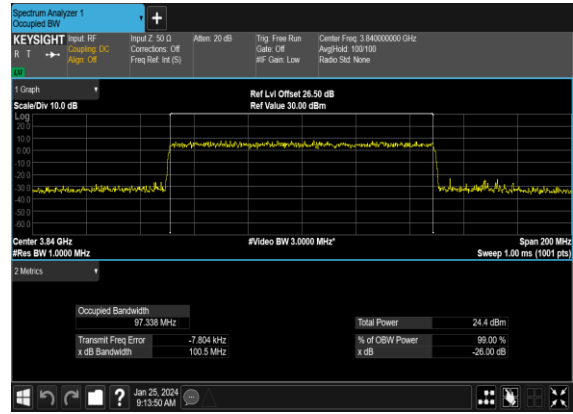

N77(100M)_CP-OFDM_64 QAM_Outer_Full_Mid_CH

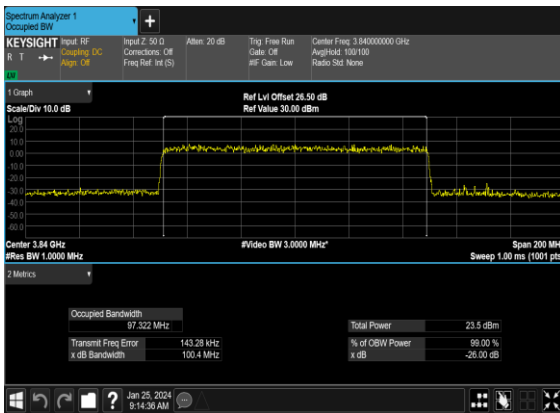

N77(100M)_CP-OFDM_256 QAM_Outer_Full_Mid_CH

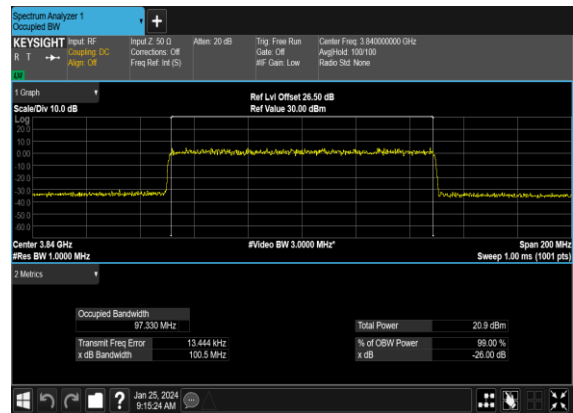

Conducted Spurious Emissions

NR Band	SCS (kHz)	Bandwidth (MHz)	Arfcn	Freq (MHz)	Modulation	RB	Result	Verdict
77	30	20	647334	3710.01	DFT-s-OFDM BPSK	1@0	see graph	---
77	30	20	647334	3710.01	DFT-s-OFDM BPSK	1@0	see graph	PASS
77	30	20	647334	3710.01	DFT-s-OFDM BPSK	1@0	see graph	PASS
77	30	20	647334	3710.01	DFT-s-OFDM QPSK	1@0	see graph	---
77	30	20	647334	3710.01	DFT-s-OFDM QPSK	1@0	see graph	PASS
77	30	20	647334	3710.01	DFT-s-OFDM QPSK	1@0	see graph	PASS
77	30	20	656000	3840.0	DFT-s-OFDM BPSK	1@0	see graph	---
77	30	20	656000	3840.0	DFT-s-OFDM BPSK	1@0	see graph	PASS
77	30	20	656000	3840.0	DFT-s-OFDM BPSK	1@0	see graph	PASS
77	30	20	656000	3840.0	DFT-s-OFDM QPSK	1@0	see graph	---
77	30	20	656000	3840.0	DFT-s-OFDM QPSK	1@0	see graph	PASS
77	30	20	656000	3840.0	DFT-s-OFDM QPSK	1@0	see graph	PASS
77	30	20	664666	3969.99	DFT-s-OFDM BPSK	1@0	see graph	---
77	30	20	664666	3969.99	DFT-s-OFDM BPSK	1@0	see graph	PASS
77	30	20	664666	3969.99	DFT-s-OFDM BPSK	1@0	see graph	PASS
77	30	20	664666	3969.99	DFT-s-OFDM QPSK	1@0	see graph	---
77	30	20	664666	3969.99	DFT-s-OFDM QPSK	1@0	see graph	PASS
77	30	20	664666	3969.99	DFT-s-OFDM QPSK	1@0	see graph	PASS
77	30	40	648000	3720.0	DFT-s-OFDM BPSK	1@0	see graph	---
77	30	40	648000	3720.0	DFT-s-OFDM BPSK	1@0	see graph	PASS
77	30	40	648000	3720.0	DFT-s-OFDM BPSK	1@0	see graph	PASS
77	30	40	648000	3720.0	DFT-s-OFDM QPSK	1@0	see graph	---
77	30	40	648000	3720.0	DFT-s-OFDM QPSK	1@0	see graph	PASS
77	30	40	648000	3720.0	DFT-s-OFDM QPSK	1@0	see graph	PASS
77	30	40	656000	3840.0	DFT-s-OFDM BPSK	1@0	see graph	---
77	30	40	656000	3840.0	DFT-s-OFDM BPSK	1@0	see graph	PASS
77	30	40	656000	3840.0	DFT-s-OFDM BPSK	1@0	see graph	PASS
77	30	40	656000	3840.0	DFT-s-OFDM QPSK	1@0	see graph	---
77	30	40	656000	3840.0	DFT-s-OFDM QPSK	1@0	see graph	PASS
77	30	40	656000	3840.0	DFT-s-OFDM QPSK	1@0	see graph	PASS
77	30	40	664000	3960.0	DFT-s-OFDM BPSK	1@0	see graph	---
77	30	40	664000	3960.0	DFT-s-OFDM BPSK	1@0	see graph	PASS
77	30	40	664000	3960.0	DFT-s-OFDM BPSK	1@0	see graph	PASS
77	30	40	664000	3960.0	DFT-s-OFDM QPSK	1@0	see graph	---
77	30	40	664000	3960.0	DFT-s-OFDM QPSK	1@0	see graph	PASS

77	30	40	664000	3960.0	DFT-s-OFDM QPSK	1@0	see graph	PASS
77	30	100	650000	3750.0	DFT-s-OFDM BPSK	1@0	see graph	---
77	30	100	650000	3750.0	DFT-s-OFDM BPSK	1@0	see graph	PASS
77	30	100	650000	3750.0	DFT-s-OFDM BPSK	1@0	see graph	PASS
77	30	100	650000	3750.0	DFT-s-OFDM QPSK	1@0	see graph	---
77	30	100	650000	3750.0	DFT-s-OFDM QPSK	1@0	see graph	PASS
77	30	100	650000	3750.0	DFT-s-OFDM QPSK	1@0	see graph	PASS
77	30	100	656000	3840.0	DFT-s-OFDM BPSK	1@0	see graph	---
77	30	100	656000	3840.0	DFT-s-OFDM BPSK	1@0	see graph	PASS
77	30	100	656000	3840.0	DFT-s-OFDM BPSK	1@0	see graph	PASS
77	30	100	656000	3840.0	DFT-s-OFDM QPSK	1@0	see graph	---
77	30	100	656000	3840.0	DFT-s-OFDM QPSK	1@0	see graph	PASS
77	30	100	656000	3840.0	DFT-s-OFDM QPSK	1@0	see graph	PASS
77	30	100	662000	3930.0	DFT-s-OFDM BPSK	1@0	see graph	---
77	30	100	662000	3930.0	DFT-s-OFDM BPSK	1@0	see graph	PASS
77	30	100	662000	3930.0	DFT-s-OFDM BPSK	1@0	see graph	PASS
77	30	100	662000	3930.0	DFT-s-OFDM QPSK	1@0	see graph	---
77	30	100	662000	3930.0	DFT-s-OFDM QPSK	1@0	see graph	PASS
77	30	100	662000	3930.0	DFT-s-OFDM QPSK	1@0	see graph	PASS

N77(20M)_DFT-s-OFDM_BPSK_Edge_1RB_Left_Low_CH

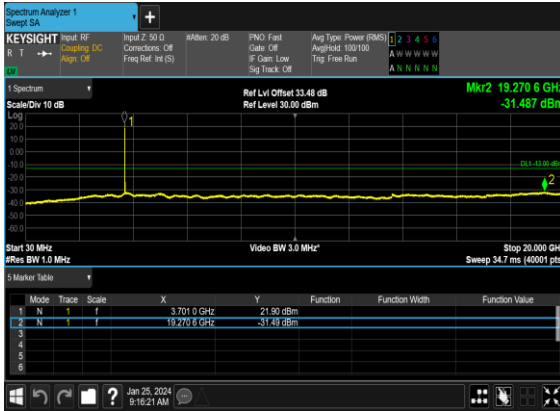

N77(20M)_DFT-s-OFDM_BPSK_Edge_1RB_Left_Low_CH

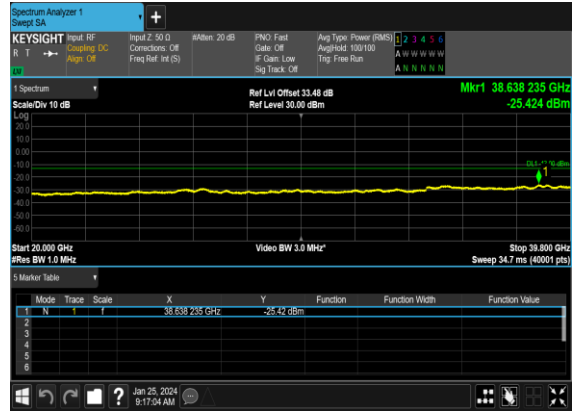

N77(20M)_DFT-s-OFDM_QPSK_Edge_1RB_Left_Low_CH

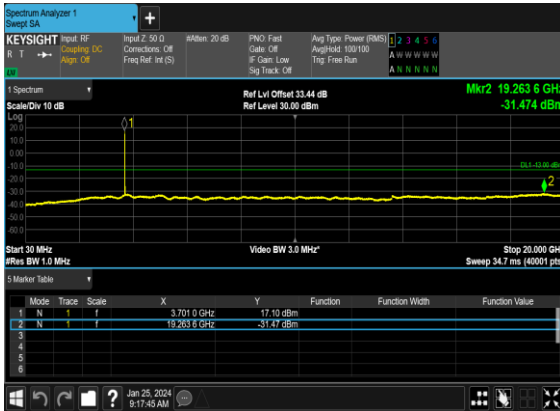

N77(20M)_DFT-s-OFDM_QPSK_Edge_1RB_Left_Low_CH

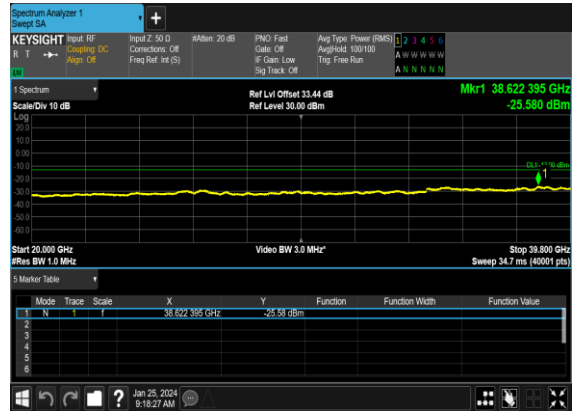

N77(20M)_DFT-s-OFDM_BPSK_Edge_1RB_Left_Mid_CH

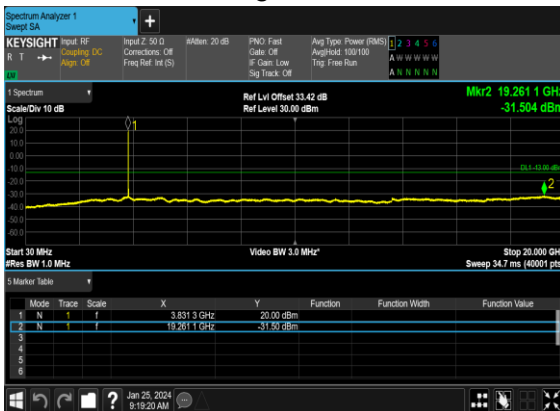

N77(20M)_DFT-s-OFDM_BPSK_Edge_1RB_Left_Mid_CH

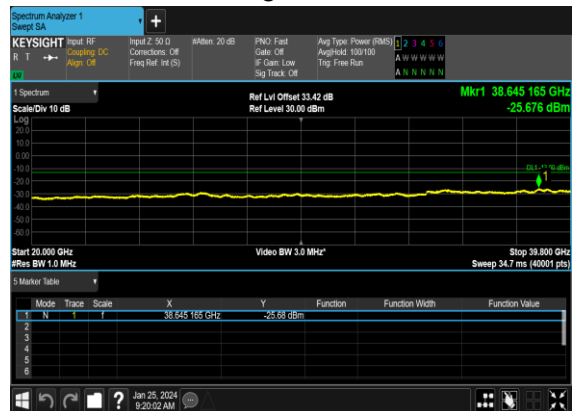

N77(20M)_DFT-s-OFDM_QPSK_Edge_1RB_Left_Mid_CH

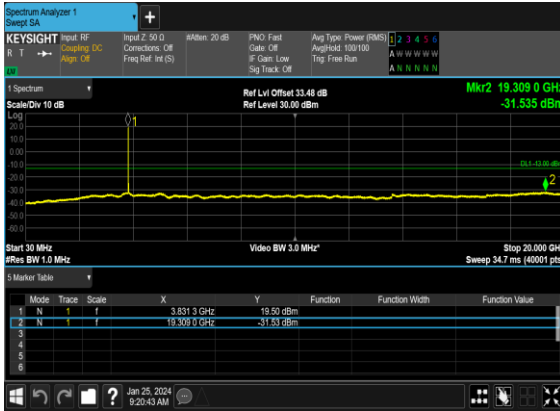

N77(20M)_DFT-s-OFDM_QPSK_Edge_1RB_Left_Mid_CH

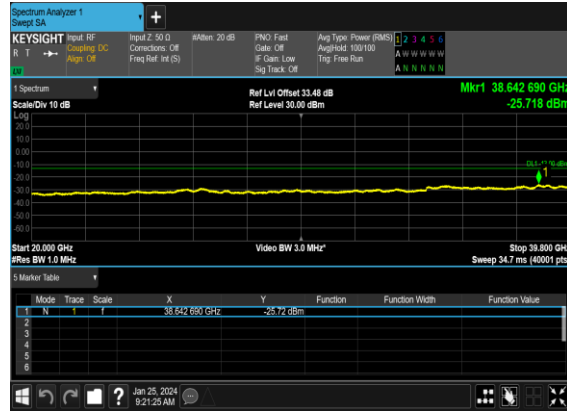

N77(20M)_DFT-s-OFDM_BPSK_Edge_1RB_Left_High_CH

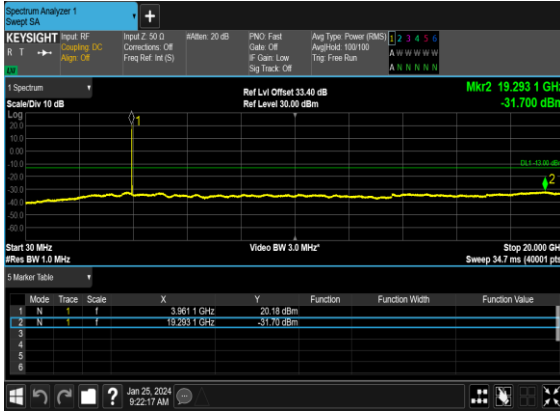

N77(20M)_DFT-s-OFDM_BPSK_Edge_1RB_Left_High_CH

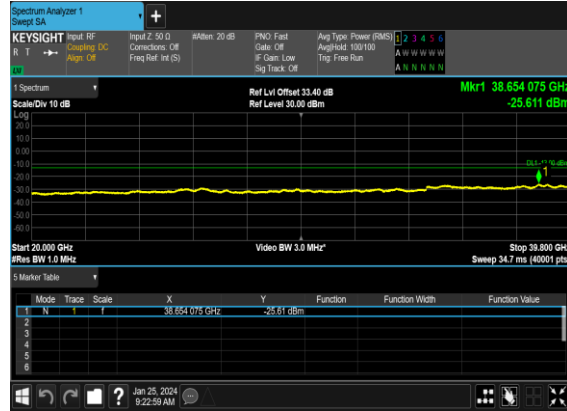

N77(20M)_DFT-s-OFDM_QPSK_Edge_1RB_Left_High_CH

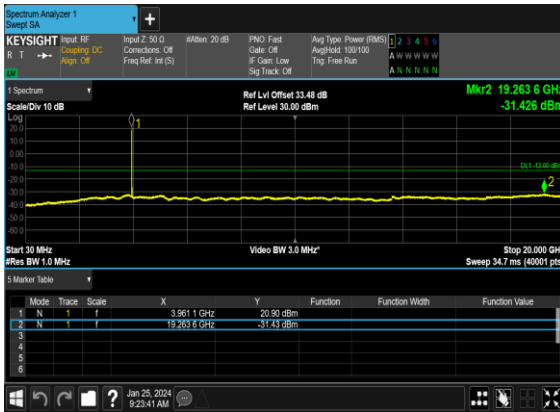

N77(20M)_DFT-s-OFDM_QPSK_Edge_1RB_Left_High_CH



N77(40M)_DFT-s-OFDM_BPSK_Edge_1RB_Left_Low_CH

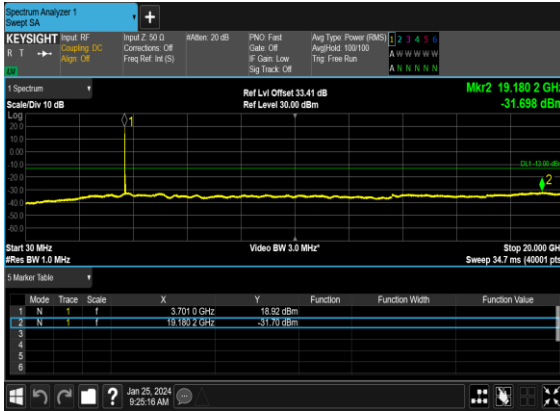

N77(40M)_DFT-s-OFDM_BPSK_Edge_1RB_Left_Low_CH

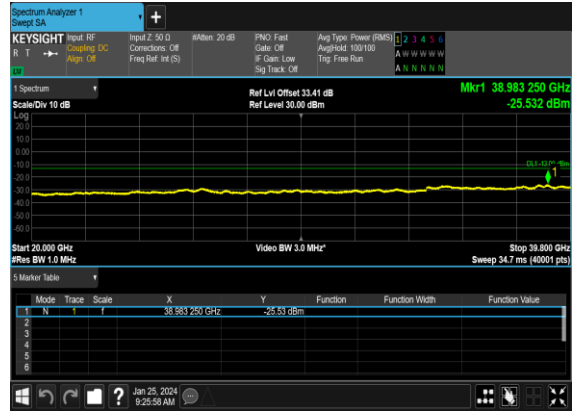

N77(40M)_DFT-s-OFDM_QPSK_Edge_1RB_Left_Low_CH

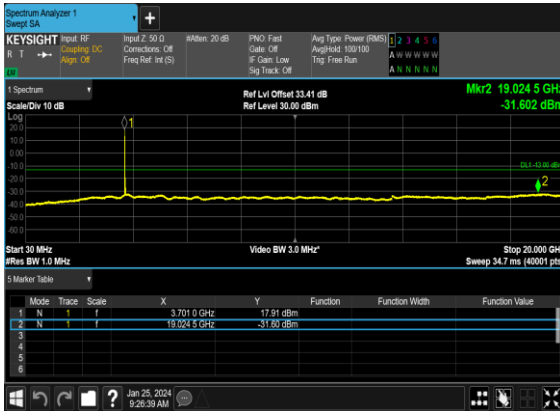

N77(40M)_DFT-s-OFDM_QPSK_Edge_1RB_Left_Low_CH

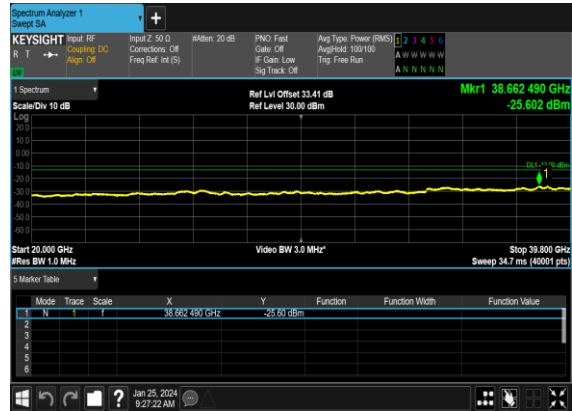

N77(40M)_DFT-s-OFDM_BPSK_Edge_1RB_Left_Mid_CH

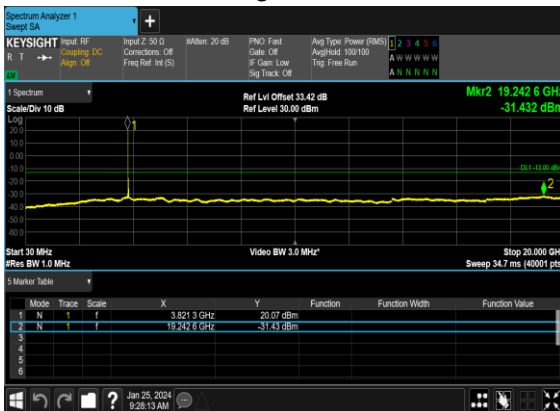

N77(40M)_DFT-s-OFDM_BPSK_Edge_1RB_Left_Mid_CH

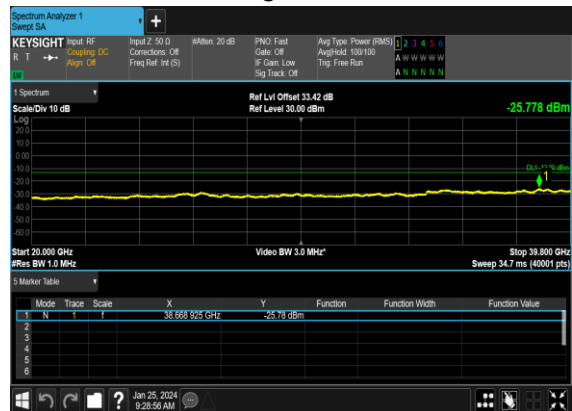

N77(40M)_DFT-s-OFDM_QPSK_Edge_1RB_Left_Mid_CH

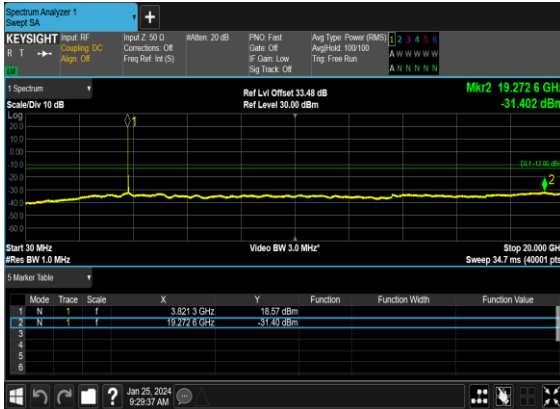

N77(40M)_DFT-s-OFDM_QPSK_Edge_1RB_Left_Mid_CH

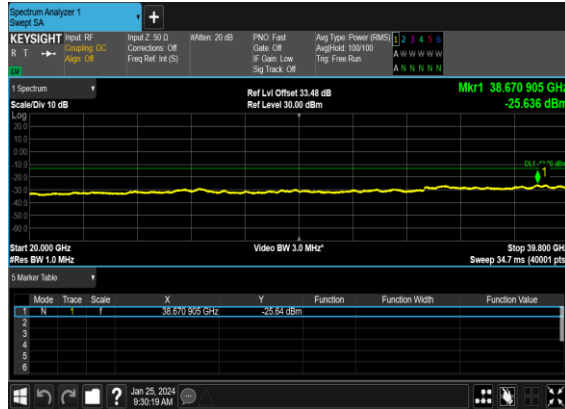

N77(40M)_DFT-s-OFDM_BPSK_Edge_1RB_Left_High_CH

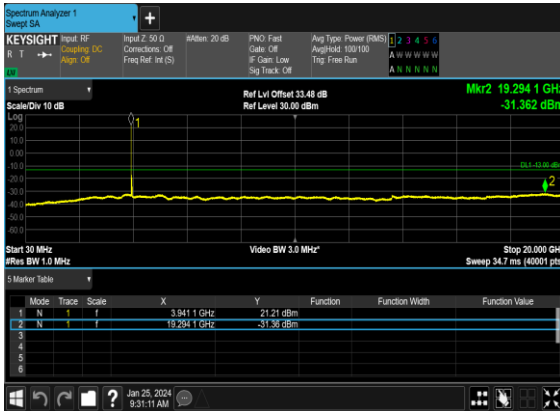

N77(40M)_DFT-s-OFDM_BPSK_Edge_1RB_Left_High_CH

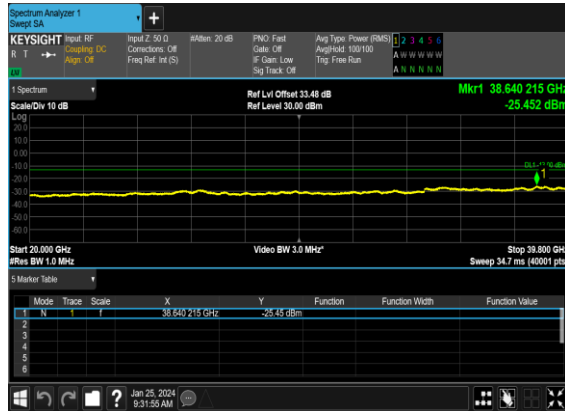

N77(40M)_DFT-s-OFDM_QPSK_Edge_1RB_Left_High_CH

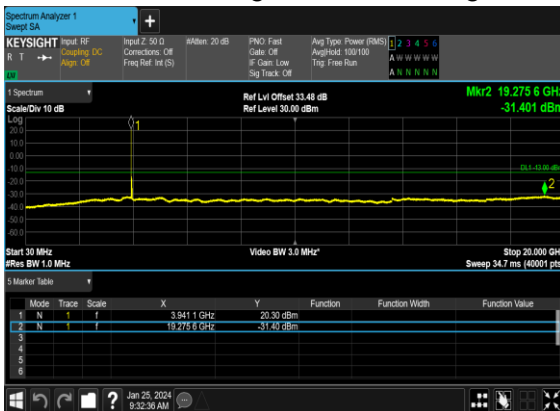

N77(40M)_DFT-s-OFDM_QPSK_Edge_1RB_Left_High_CH

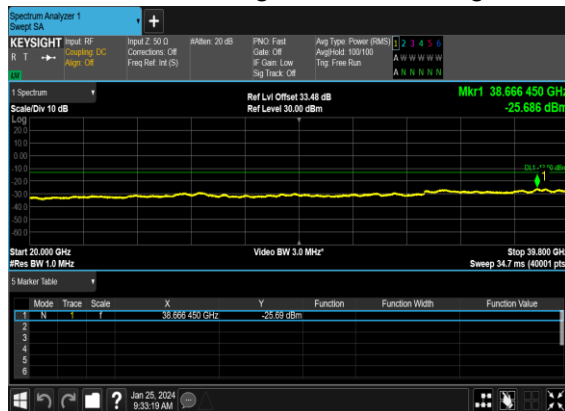

N77(100M)_DFT-s-OFDM_BPSK_Edge_1RB_Left_Low_CH

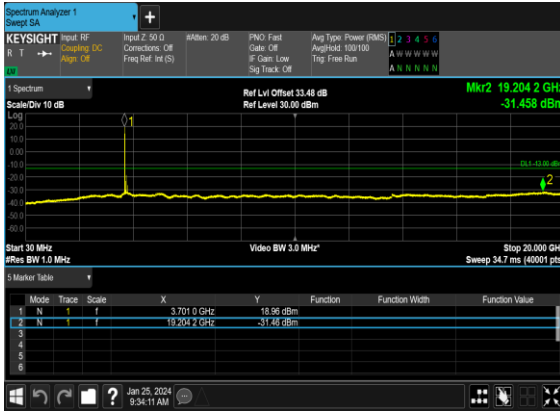

N77(100M)_DFT-s-OFDM_BPSK_Edge_1RB_Left_Low_CH

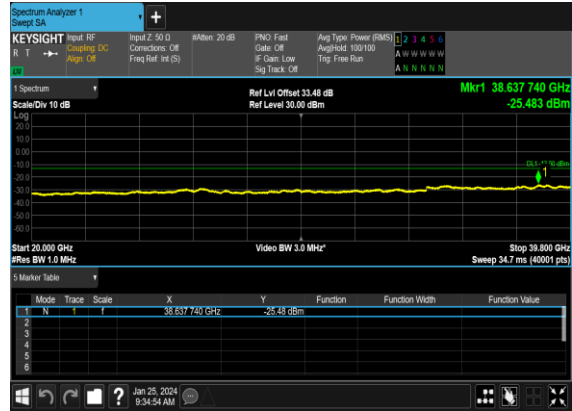

N77(100M)_DFT-s-OFDM_QPSK_Edge_1RB_Left_Low_CH

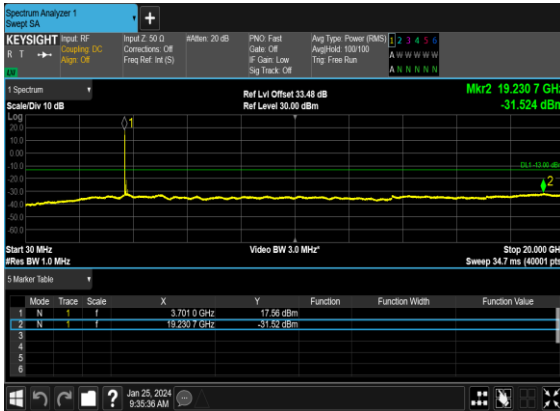

N77(100M)_DFT-s-OFDM_QPSK_Edge_1RB_Left_Low_CH

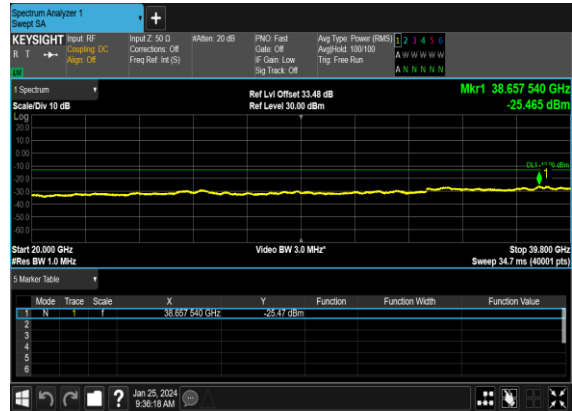

N77(100M)_DFT-s-OFDM_BPSK_Edge_1RB_Left_Mid_CH

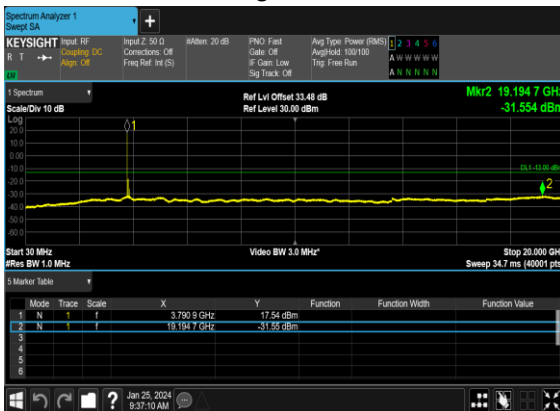

N77(100M)_DFT-s-OFDM_BPSK_Edge_1RB_Left_Mid_CH

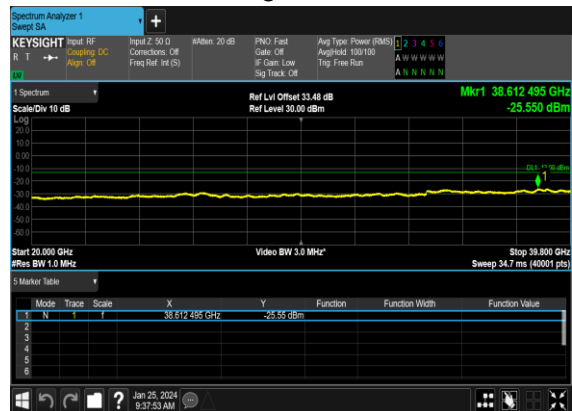

N77(100M)_DFT-s-OFDM_QPSK_Edge_1RB_Left_Mid_CH

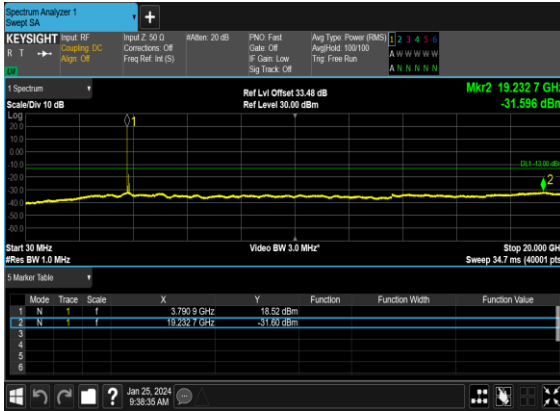

N77(100M)_DFT-s-OFDM_QPSK_Edge_1RB_Left_Mid_CH

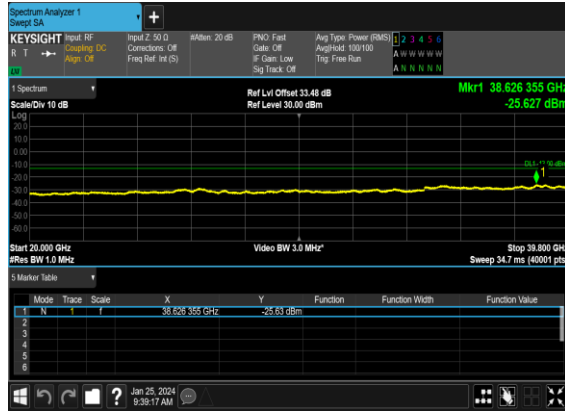

N77(100M)_DFT-s-OFDM_BPSK_Edge_1RB_Left_High_CH

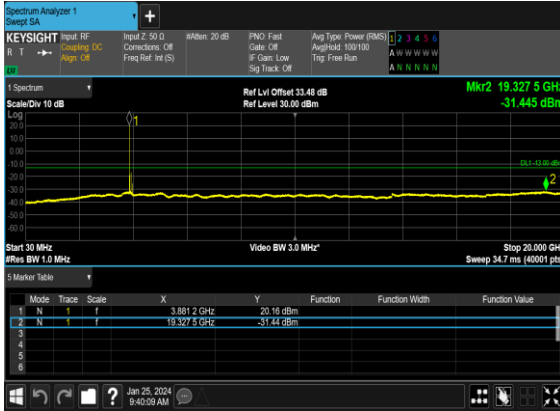

N77(100M)_DFT-s-OFDM_BPSK_Edge_1RB_Left_High_CH

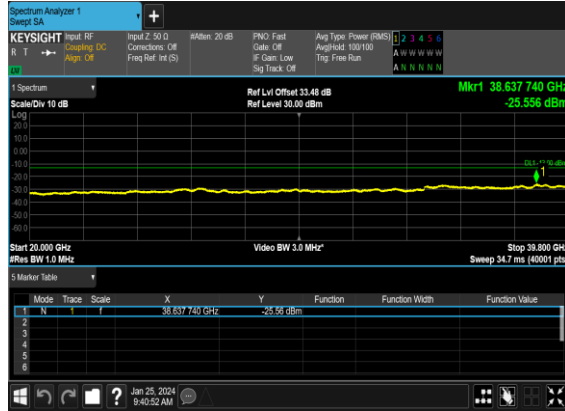

N77(100M)_DFT-s-OFDM_QPSK_Edge_1RB_Left_High_CH

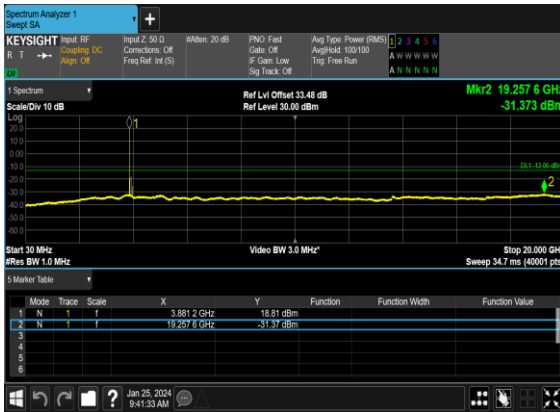

N77(100M)_DFT-s-OFDM_QPSK_Edge_1RB_Left_High_CH

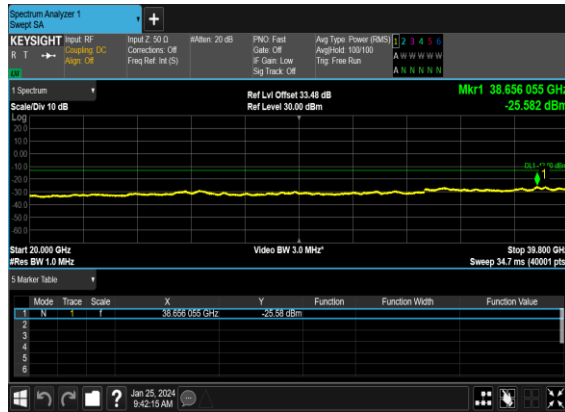

Conducted Band Edge

NR Band	SCS (kHz)	Bandwidth (MHz)	Arfcn	Freq (MHz)	Modulation	RB	Result	Verdict
77	30	20	647334	3710.01	DFT-s-OFDM BPSK	1@0	see graph	PASS
77	30	20	647334	3710.01	DFT-s-OFDM QPSK	1@0	see graph	PASS
77	30	20	647334	3710.01	DFT-s-OFDM BPSK	50@0	see graph	PASS
77	30	20	647334	3710.01	DFT-s-OFDM QPSK	50@0	see graph	PASS
77	30	20	664666	3969.99	DFT-s-OFDM BPSK	1@50	see graph	PASS
77	30	20	664666	3969.99	DFT-s-OFDM QPSK	1@50	see graph	PASS
77	30	20	664666	3969.99	DFT-s-OFDM BPSK	50@0	see graph	PASS
77	30	20	664666	3969.99	DFT-s-OFDM QPSK	50@0	see graph	PASS
77	30	40	648000	3720.0	DFT-s-OFDM BPSK	1@0	see graph	PASS
77	30	40	648000	3720.0	DFT-s-OFDM QPSK	1@0	see graph	PASS
77	30	40	648000	3720.0	DFT-s-OFDM BPSK	100@0	see graph	PASS
77	30	40	648000	3720.0	DFT-s-OFDM QPSK	100@0	see graph	PASS
77	30	40	664000	3960.0	DFT-s-OFDM BPSK	1@105	see graph	PASS
77	30	40	664000	3960.0	DFT-s-OFDM QPSK	1@105	see graph	PASS
77	30	40	664000	3960.0	DFT-s-OFDM BPSK	100@0	see graph	PASS
77	30	40	664000	3960.0	DFT-s-OFDM QPSK	100@0	see graph	PASS
77	30	100	650000	3750.0	DFT-s-OFDM BPSK	1@0	see graph	PASS
77	30	100	650000	3750.0	DFT-s-OFDM QPSK	1@0	see graph	PASS
77	30	100	650000	3750.0	DFT-s-OFDM BPSK	270@0	see graph	PASS
77	30	100	650000	3750.0	DFT-s-OFDM QPSK	270@0	see graph	PASS
77	30	100	662000	3930.0	DFT-s-OFDM BPSK	1@272	see graph	PASS
77	30	100	662000	3930.0	DFT-s-OFDM QPSK	1@272	see graph	PASS
77	30	100	662000	3930.0	DFT-s-OFDM BPSK	270@0	see graph	PASS
77	30	100	662000	3930.0	DFT-s-OFDM QPSK	270@0	see graph	PASS

N77(20M)_DFT-s-OFDM_BPSK_Edge_1RB_Left_Low_CH



N77(20M)_DFT-s-OFDM_QPSK_Edge_1RB_Left_Low_CH

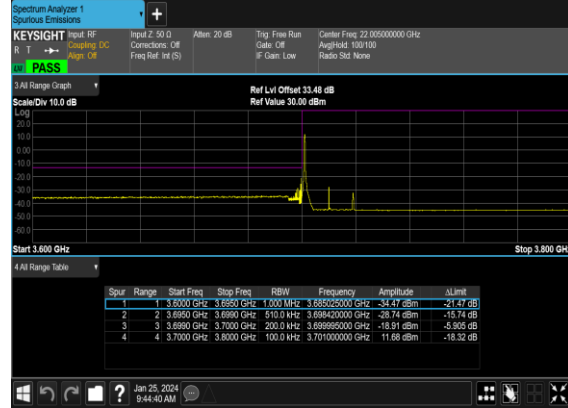

N77(20M)_DFT-s-OFDM_BPSK_Outer_Full_Low_CH

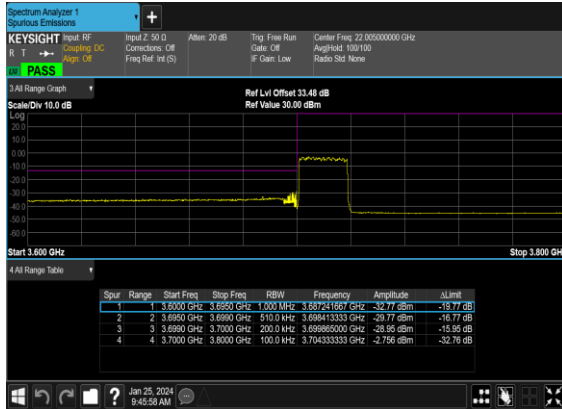

N77(20M)_DFT-s-OFDM_QPSK_Outer_Full_Low_CH

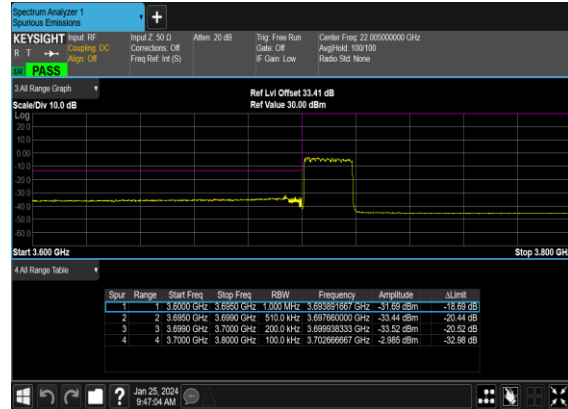

N77(20M)_DFT-s-OFDM_BPSK_Edge_1RB_Right_High_CH

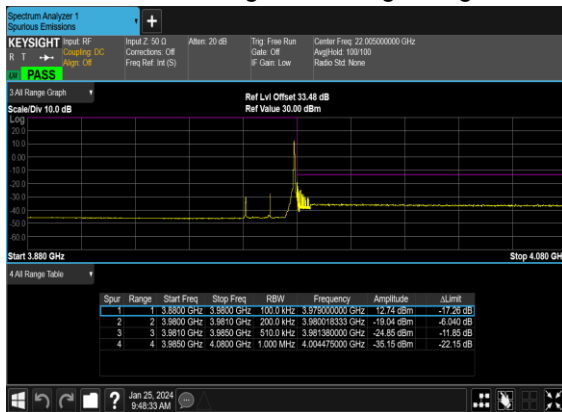

N77(20M)_DFT-s-OFDM_QPSK_Edge_1RB_Right_High_CH

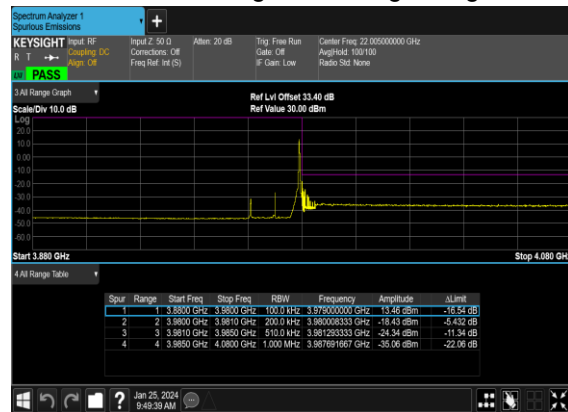

N77(20M)_DFT-s-OFDM_BPSK_Outer_Full_High_CH



N77(20M)_DFT-s-OFDM_QPSK_Outer_Full_High_CH

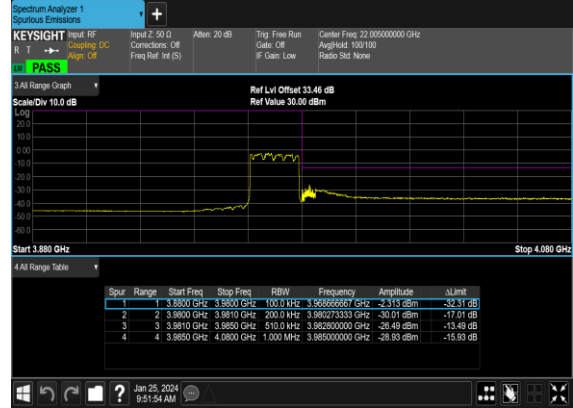

N77(40M)_DFT-s-OFDM_BPSK_Edge_1RB_Left_Low_CH

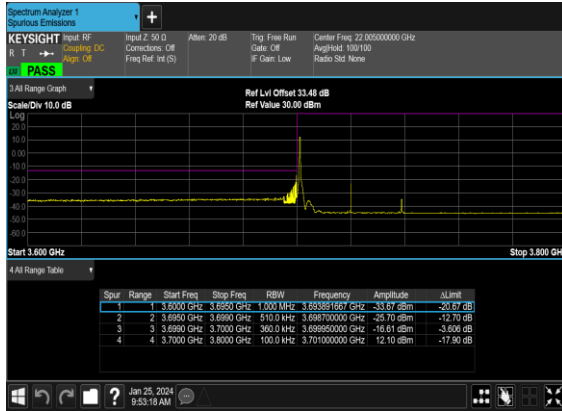

N77(40M)_DFT-s-OFDM_QPSK_Edge_1RB_Left_Low_CH

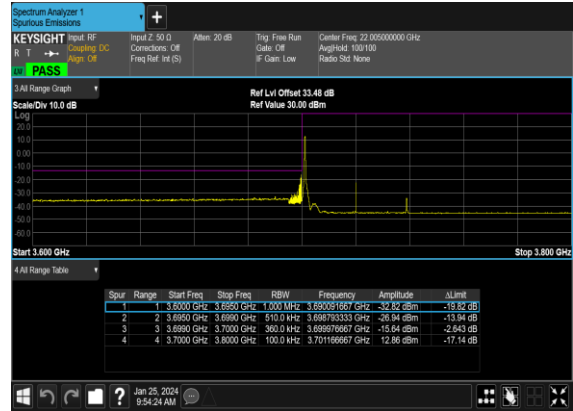

N77(40M)_DFT-s-OFDM_BPSK_Outer_Full_Low_CH

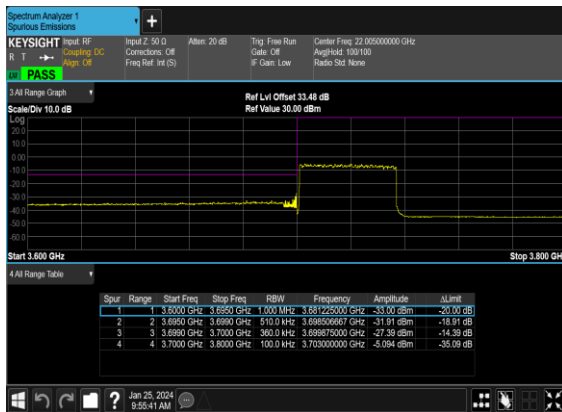

N77(40M)_DFT-s-OFDM_QPSK_Outer_Full_Low_CH

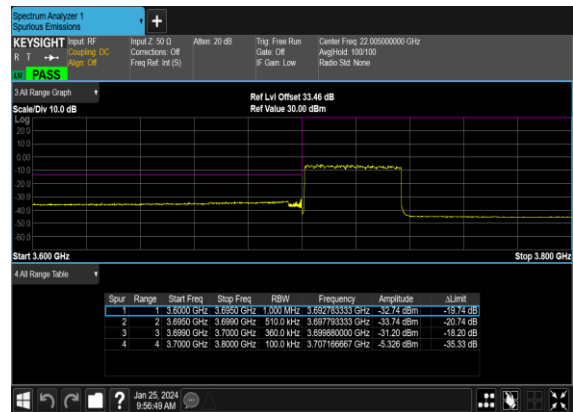

N77(40M)_DFT-s-OFDM_BPSK_Edge_1RB_Right_High_CH

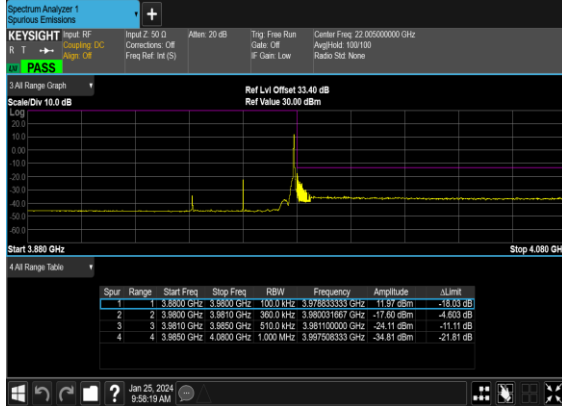

N77(40M)_DFT-s-OFDM_QPSK_Edge_1RB_Right_High_CH

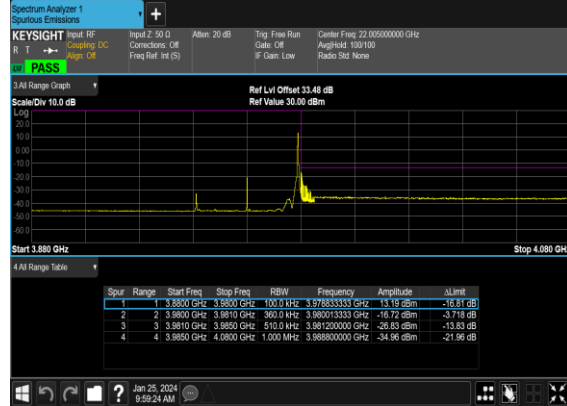

N77(40M)_DFT-s-OFDM_BPSK_Outer_Full_High_CH

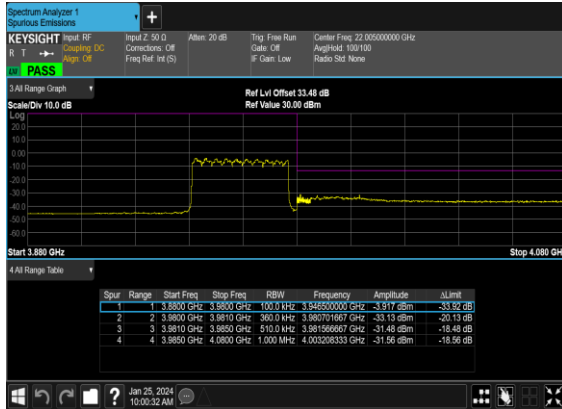

N77(40M)_DFT-s-OFDM_QPSK_Outer_Full_High_CH

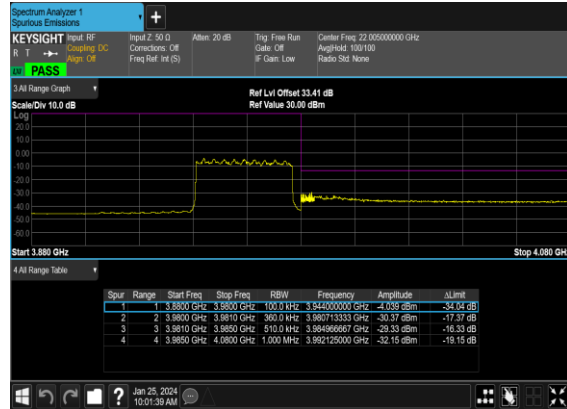

N77(100M)_DFT-s-OFDM_BPSK_Edge_1RB_Left_Low_CH

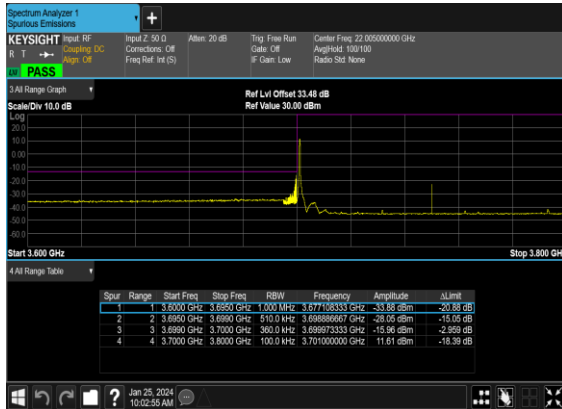

N77(100M)_DFT-s-OFDM_QPSK_Edge_1RB_Left_Low_CH

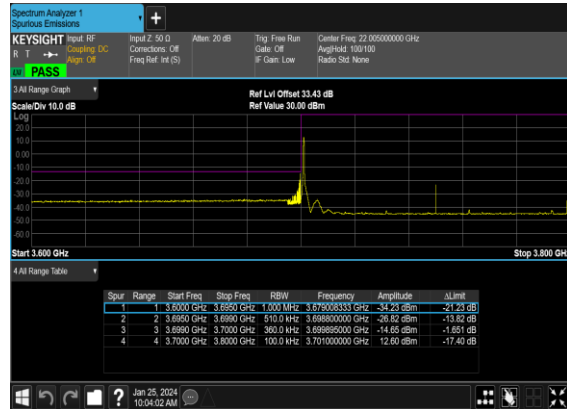

N77(100M)_DFT-s-OFDM_BPSK_Outer_Full_Low_CH

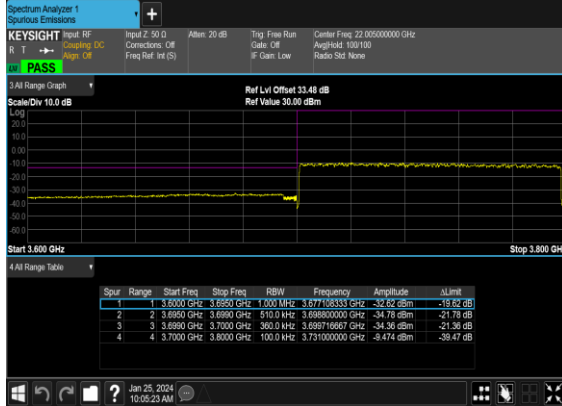

N77(100M)_DFT-s-OFDM_QPSK_Outer_Full_Low_CH

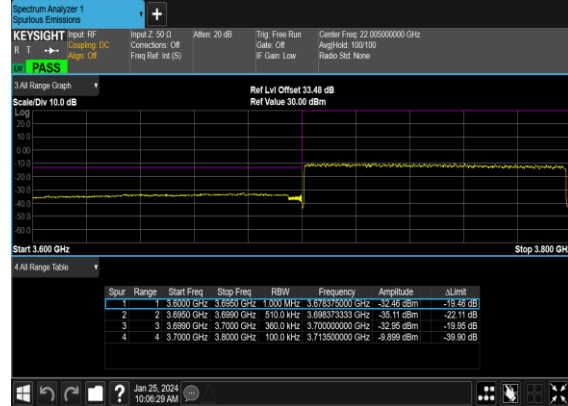

N77(100M)_DFT-s-OFDM_BPSK_Edge_1RB_Right_High_CH

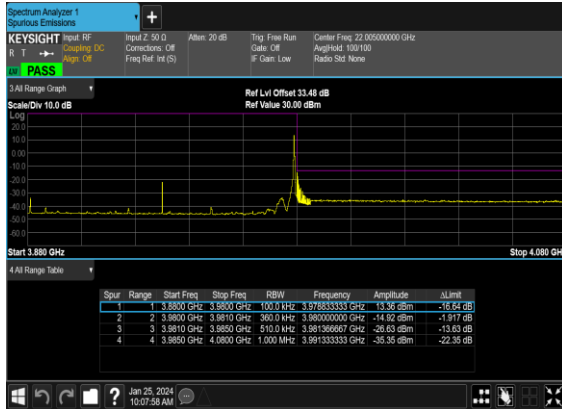

N77(100M)_DFT-s-OFDM_QPSK_Edge_1RB_Right_High_CH

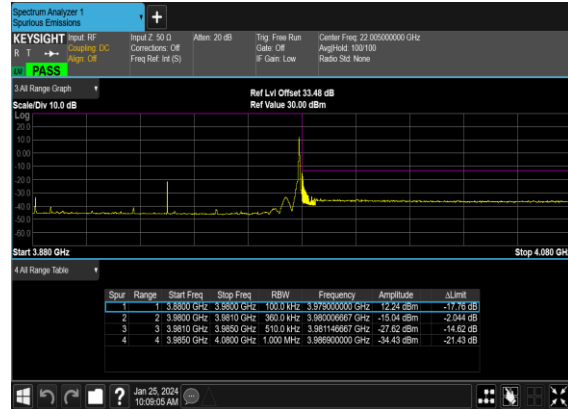

N77(100M)_DFT-s-OFDM_BPSK_Outer_Full_High_CH

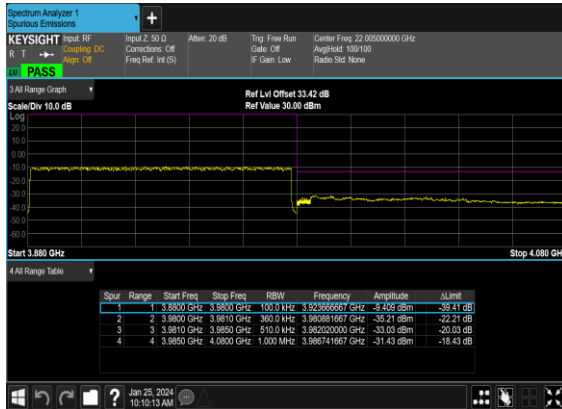

N77(100M)_DFT-s-OFDM_QPSK_Outer_Full_High_CH

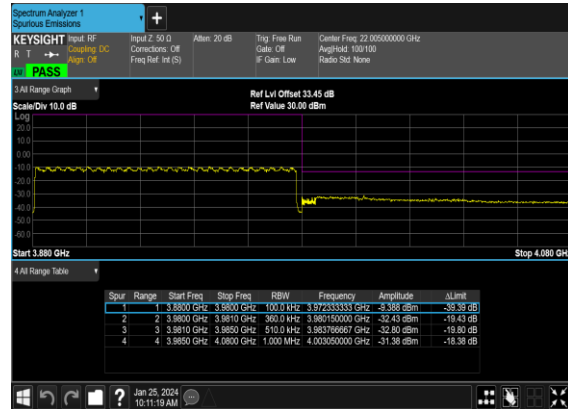

FR1 N78 (ANT0)

Frequency Stability

NR Band	SCS (kHz)	Bandwidth (MHz)	Arfcn	Freq (MHz)	Modulation	RB	Deviation (ppm)	Verdict	Environment
78	30	80	650000	3750.0	DFT-s-OFDM QPSK	216@0	-0.0015	PASS	NV
78	30	80	650000	3750.0	DFT-s-OFDM QPSK	216@0	0.0022	PASS	LV
78	30	80	650000	3750.0	DFT-s-OFDM QPSK	216@0	0.0023	PASS	HV
78	30	80	650000	3750.0	DFT-s-OFDM QPSK	216@0	0.0031	PASS	-30°C
78	30	80	650000	3750.0	DFT-s-OFDM QPSK	216@0	0.0033	PASS	-20°C
78	30	80	650000	3750.0	DFT-s-OFDM QPSK	216@0	-0.0022	PASS	-10°C
78	30	80	650000	3750.0	DFT-s-OFDM QPSK	216@0	0.0021	PASS	0°C
78	30	80	650000	3750.0	DFT-s-OFDM QPSK	216@0	-0.0014	PASS	10°C
78	30	80	650000	3750.0	DFT-s-OFDM QPSK	216@0	0.0011	PASS	20°C
78	30	80	650000	3750.0	DFT-s-OFDM QPSK	216@0	0.0012	PASS	30°C
78	30	80	650000	3750.0	DFT-s-OFDM QPSK	216@0	0.0013	PASS	40°C
78	30	80	650000	3750.0	DFT-s-OFDM QPSK	216@0	0.0035	PASS	50°C

Peak to Average Ratio

NR Band	SCS (kHz)	Bandwidth (MHz)	Arfcn	Freq (MHz)	Modulation	RB	Result (dB)	Limit (dB)	Verdict
78	30	80	650000	3750.0	DFT-s-OFDM PI/2 BPSK	216@0	6.19	13	PASS
78	30	80	650000	3750.0	DFT-s-OFDM PI/2 BPSK	1@0	5.68	13	PASS
78	30	80	650000	3750.0	DFT-s-OFDM QPSK	216@0	8.36	13	PASS
78	30	80	650000	3750.0	DFT-s-OFDM QPSK	1@0	9.39	13	PASS

N78(80M)_DFT-s-OFDM_PI_2-BPSK_Outer_Full_Mid_CH

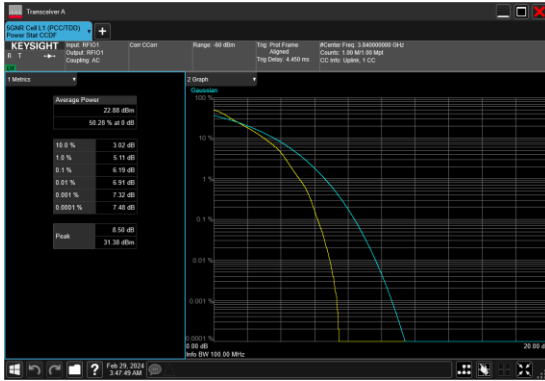

N78(80M)_DFT-s-OFDM_PI_2-BPSK_Edge_1RB_Left_Mid_CH

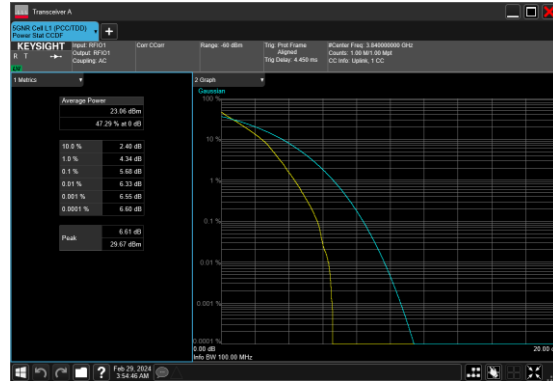

N78(80M)_DFT-s-OFDM_QPSK_Outer_Full_Mid_CH

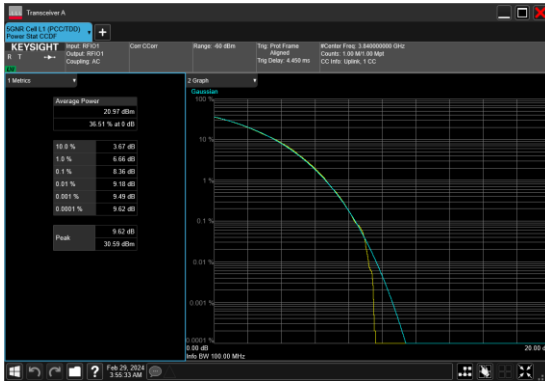

N78(80M)_DFT-s-OFDM_QPSK_Edge_1RB_Left_Mid_CH

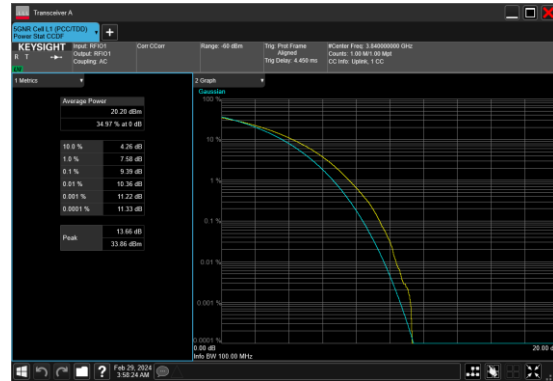

Occupied Bandwidth

NR Band	SCS (kHz)	Bandwidth (MHz)	Arfcn	Freq (MHz)	Modulation	RB	OBW (MHz)	26dB BW (MHz)
78	30	80	650000	3750.0	CP-OFDM QPSK	217@0	77.348	79.81
78	30	80	650000	3750.0	CP-OFDM 16 QAM	217@0	77.447	79.81
78	30	80	650000	3750.0	CP-OFDM 64 QAM	217@0	77.559	79.86
78	30	80	650000	3750.0	CP-OFDM 256 QAM	217@0	77.381	80.13