



FCC RF Test Report

APPLICANT : FCNT LLC.
EQUIPMENT : Mobile cellular phone
BRAND NAME : arrows We2 Plus
MODEL NAME : F-51E
FCC ID : 2BEPUFMP193
STANDARD : 47 CFR Part 2, 22(H), 24(E), 27(L), 27(H), 27(M)
CLASSIFICATION : PCS Licensed Transmitter Held to Ear (PCE)
TEST DATE(S) : Feb. 25, 2024 ~ Apr. 07, 2024

We, Sporton International Inc. (Kunshan), would like to declare that the tested sample has been evaluated in accordance with the procedures given in ANSI C63.26-2015 and shown compliance with the applicable technical standards.

The test results in this report apply exclusively to the tested model / sample. Without written approval of Sporton International Inc. (Kunshan), the test report shall not be reproduced except in full.

Jason Jia

Approved by: Jason Jia



Sporton International Inc. (Kunshan)

**No. 1098, Pengxi North Road, Kunshan Economic Development Zone Jiangsu Province 215300
People's Republic of China**



TABLE OF CONTENTS

REVISION HISTORY... 3
SUMMARY OF TEST RESULT ... 4
1 GENERAL DESCRIPTION ... 6
1.1 Applicant ... 6
1.2 Manufacturer ... 6
1.3 Product Feature of Equipment Under Test ... 6
1.4 Product Specification of Equipment Under Test ... 6
1.5 Modification of EUT ... 7
1.6 Maximum ERP/EIRP Power and Emission Designator ... 8
1.7 Testing Location ... 10
1.8 Test Software ... 10
1.9 Applicable Standards ... 10
2 TEST CONFIGURATION OF EQUIPMENT UNDER TEST ... 11
2.1 Test Mode ... 11
2.2 Connection Diagram of Test System ... 13
2.3 Support Unit used in test configuration and system ... 13
2.4 Measurement Results Explanation Example ... 13
2.5 Frequency List of Low/Middle/High Channels ... 14
3 CONDUCTED TEST ITEMS ... 17
3.1 Measuring Instruments ... 17
3.2 Test Setup ... 17
3.3 Test Result of Conducted Test ... 17
3.4 Conducted Output Power and ERP/EIRP ... 18
3.5 Peak-to-Average Ratio ... 19
3.6 Occupied Bandwidth ... 20
3.7 Conducted Band Edge ... 21
3.8 Conducted Spurious Emission ... 23
3.9 Frequency Stability ... 24
4 RADIATED TEST ITEMS ... 25
4.1 Measuring Instruments ... 25
4.2 Test Setup ... 25
4.3 Test Result of Radiated Test ... 26
4.4 Radiated Spurious Emission ... 27
5 LIST OF MEASURING EQUIPMENT ... 28
6 MEASUREMENT UNCERTAINTY ... 29
APPENDIX A. TEST RESULTS OF CONDUCTED TEST
APPENDIX B. TEST RESULTS OF RADIATED TEST
APPENDIX C. TEST SETUP PHOTOGRAPHS



REVISION HISTORY

REPORT NO.	VERSION	DESCRIPTION	ISSUED DATE
FG3D0607B	Rev. 01	Initial issue of report	May 22, 2024



SUMMARY OF TEST RESULT

Report Section	FCC Rule	Description	Limit	Result	Remark
3.4	§2.1046	Conducted Output Power	-	Report Only	-
	§22.913(a)(5)	Effective Radiated Power (Band 5)	ERP < 7 Watt	PASS	-
	§27.50(c)(10)	Effective Radiated Power (Band 12)	ERP < 3 Watt		-
	§24.232(c) §27.50(h)(2)	Equivalent Isotropic Radiated Power (Band 2) (Band 7) (Band 38) (Band 41)	EIRP < 2Watt		-
	§27.50(d)(4)	Equivalent Isotropic Radiated Power (Band 4)	EIRP < 1Watt		-
3.5	§24.232(d)	Peak-to-Average Ratio	<13 dB		PASS
3.6	§2.1049	Occupied Bandwidth	-	Report Only	-
3.7	§2.1051 §22.917(a) §24.238(a) §27.53(g) §27.53(h)	Conducted Band Edge Measurement (Band 2) (Band 4) (Band 5) (Band 12)	< 43+10log ₁₀ (P[Watts])	PASS	-
	§27.53(m)(4)	Conducted Band Edge Measurement (Band 7) (Band 38) (Band 41)	§27.53(m)(4)		
3.8	§2.1051 §22.917(a) §24.238(a) §27.53(g) §27.53(h)	Conducted Spurious Emission (Band 2) (Band 4) (Band 5) (Band 12)	< 43+10log ₁₀ (P[Watts])	PASS	-
	§2.1051 §27.53(m)(4)	Conducted Spurious Emission (Band 7) (Band 38) (Band 41)	< 55+10log ₁₀ (P[Watts])		
3.9	§2.1055 §22.355	Frequency Stability Temperature & Voltage	< 2.5 ppm for Part 22	PASS	-
	§2.1055 §24.235 §27.54		Within Authorized Band		
4.4	§2.1053 §22.917(a) §24.238(a) §27.53(g) §27.53(h)	Radiated Spurious Emission (Band 2) (Band 4) (Band 5) (Band 12)	< 43+10log ₁₀ (P[Watts])	PASS	Under limit 27.91 dB at 12918.00 MHz
	§2.1053 §27.53(m)(4)	Radiated Spurious Emission (Band 7) (Band 38) (Band 41)	< 55+10log ₁₀ (P[Watts])		



Conformity Assessment Condition:

1. The test results (PASS/FAIL) with all measurement uncertainty excluded are presented against the regulation limits or in accordance with the requirements stipulated by the applicant/manufacturee who shall bear all the risks of non-compliance that may potentially occur if measurement uncertainty is taken into account.
2. The measurement uncertainty please refer to each test result in the section "Measurement Uncertainty"

Disclaimer:

The product specifications of the EUT presented in the test report that may affect the test assessments are declared by the manufacturer who shall take full responsibility for the authenticity.



1 General Description

1.1 Applicant

FCNT LLC.

Sanki Yamato Bldg. 3F, 7-10-1, Chuorinkan, Yamato-shi, Kanagawa, 242-0007, Japan

1.2 Manufacturer

FCNT LLC.

Sanki Yamato Bldg. 3F, 7-10-1, Chuorinkan, Yamato-shi, Kanagawa, 242-0007, Japan

1.3 Product Feature of Equipment Under Test

Product Feature	
Equipment	Mobile cellular phone
Brand Name	arrows We2 Plus
Model Name	F-51E
FCC ID	2BEPUFMP193
IMEI Code	Conducted: 354713660023128/354713660023136 Radiation: 354713660051707/354713660051715
HW Version	V4
SW Version	Nagoya_QN7021A_Fac_V011
EUT Stage	Identical Prototype

1.4 Product Specification of Equipment Under Test

Standards-related Product Specification	
Tx Frequency	LTE Band 2 : 1850 MHz ~ 1910 MHz LTE Band 4 : 1710 MHz ~ 1755 MHz LTE Band 5 : 824 MHz ~ 849 MHz LTE Band 7 : 2500 MHz ~ 2570 MHz LTE Band 12 : 699 MHz ~ 716 MHz LTE Band 38 : 2570 MHz ~ 2620 MHz LTE Band 41 : 2496 MHz ~ 2690 MHz
Rx Frequency	LTE Band 2 : 1930 MHz ~ 1990 MHz LTE Band 4 : 2110 MHz ~ 2155 MHz LTE Band 5 : 869 MHz ~ 894 MHz LTE Band 7 : 2620 MHz ~ 2690 MHz LTE Band 12 : 729 MHz ~ 746 MHz LTE Band 38 : 2570 MHz ~ 2620 MHz LTE Band 41 : 2496 MHz ~ 2690 MHz
Bandwidth	LTE Band 2 : 1.4MHz / 3MHz / 5MHz / 10MHz / 15MHz / 20MHz LTE Band 4 : 1.4MHz / 3MHz / 5MHz / 10MHz / 15MHz / 20MHz LTE Band 5 : 1.4MHz / 3MHz / 5MHz / 10MHz LTE Band 7 : 5MHz / 10MHz / 15MHz / 20MHz LTE Band 12 : 1.4MHz / 3MHz / 5MHz / 10MHz LTE Band 38 : 5MHz / 10MHz / 15MHz / 20MHz



	LTE Band 41 : 5MHz / 10MHz / 15MHz / 20MHz
Maximum Output Power to Antenna	<Ant 0> LTE Band 5 : 22.33 dBm LTE Band 12 : 22.44 dBm <Ant 1> LTE Band 2 : 22.43 dBm LTE Band 4 : 22.63 dBm LTE Band 7 : 22.53 dBm LTE Band 38 : 22.54 dBm LTE Band 41 : 24.78 dBm <Ant 4> LTE Band 2 : 22.51 dBm LTE Band 4 : 22.48 dBm LTE Band 5 : 22.97 dBm LTE Band 7 : 22.54 dBm LTE Band 12 : 22.95 dBm LTE Band 38 : 22.46 dBm LTE Band 41 : 24.55 dBm
Antenna Gain	<Ant 0> LTE Band 5 : -4.8 dBi LTE Band 12 : -5.0 dBi <Ant 1> LTE Band 2 : -3.3 dBi LTE Band 4 : -3.4 dBi LTE Band 7 : -2.8 dBi LTE Band 38 : -3.2 dBi LTE Band 41 : -3.2 dBi <Ant 4> LTE Band 2 : -3.3 dBi LTE Band 4 : -3.4 dBi LTE Band 5 : -4.5 dBi LTE Band 7 : -3.1 dBi LTE Band 12 : -4.9 dBi LTE Band 38 : -3.2 dBi LTE Band 41 : -3.1 dBi
Type of Modulation	QPSK / 16QAM / 64QAM

Note:

1. The EIRP is calculated from Output power and antenna gain, thus only the maximum EIRP of Antenna 4 for LTE Band 2/5/12, and Antenna 1 for LTE Band 4/7/38/41 are shown in the report.
2. LTE Band 41 support two PA paths, one PA path for LTE single carrier and other PA path for NSA mode, both the PA are full tested, only the maximum EIRP are shown in the report.
3. LTE Band 41 support HPUE (PC2).

1.5 Modification of EUT

No modifications are made to the EUT during all test items.



1.6 Maximum ERP/EIRP Power and Emission Designator

LTE Band 2		QPSK		16QAM/64QAM	
BW (MHz)	Frequency Range (MHz)	Maximum EIRP(W)	Emission Designator (99%OBW)	Maximum EIRP(W)	Emission Designator (99%OBW)
1.4	1850.7 ~ 1909.3	0.0807	1M09G7D	0.0635	1M11W7D
3	1851.5 ~ 1908.5	0.0824	2M75G7D	0.0643	2M73W7D
5	1852.5 ~ 1907.5	0.0818	4M51G7D	0.0647	4M50W7D
10	1855.0 ~ 1905.0	0.0824	9M09G7D	0.0646	9M05W7D
15	1857.5 ~ 1902.5	0.0828	13M5G7D	0.0635	13M5W7D
20	1860.0 ~ 1900.0	0.0834	17M9G7D	0.0655	17M9W7D
LTE Band 4		QPSK		16QAM/64QAM	
BW (MHz)	Frequency Range (MHz)	Maximum EIRP(W)	Emission Designator (99%OBW)	Maximum EIRP(W)	Emission Designator (99%OBW)
1.4	1710.7 ~ 1754.3	0.0811	1M09G7D	0.0635	1M09W7D
3	1711.5 ~ 1753.5	0.0820	2M73G7D	0.0644	27M3W7D
5	1712.5 ~ 1752.5	0.0804	4M50G7D	0.0634	4M50W7D
10	1715.0 ~ 1750.0	0.0828	9M07G7D	0.0634	9M07W7D
15	1717.5 ~ 1747.5	0.0820	13M5G7D	0.0646	13M5W7D
20	1720.0 ~ 1745.0	0.0838	17M9G7D	0.0650	17M9W7D
LTE Band 5		QPSK		16QAM/64QAM	
BW (MHz)	Frequency Range (MHz)	Maximum ERP(W)	Emission Designator (99%OBW)	Maximum ERP(W)	Emission Designator (99%OBW)
1.4	824.7 ~ 848.3	0.0414	1M10G7D	0.0316	1M10W7D
3	825.5 ~ 847.5	0.0419	2M75G7D	0.0329	2M73W7D
5	826.5 ~ 846.5	0.0416	4M49G7D	0.0331	4M49W7D
10	829.0 ~ 844.0	0.0429	9M05G7D	0.0340	8M99W7D
LTE Band 7		QPSK		16QAM/64QAM	
BW (MHz)	Frequency Range (MHz)	Maximum EIRP(W)	Emission Designator (99%OBW)	Maximum EIRP(W)	Emission Designator (99%OBW)
5	2502.5 ~ 2567.5	0.0929	4M48G7D	0.0750	4M49W7D
10	2505.0 ~ 2565.0	0.0923	9M05G7D	0.0741	9M05W7D
15	2507.5 ~ 2562.5	0.0927	13M5G7D	0.0752	13M5W7D
20	2510.0 ~ 2560.0	0.0940	17M8G7D	0.0762	17M9W7D



LTE Band 12		QPSK		16QAM/64QAM	
BW (MHz)	Frequency Range (MHz)	Maximum ERP(W)	Emission Designator (99%OBW)	Maximum ERP(W)	Emission Designator (99%OBW)
1.4	699.7 ~ 715.3	0.0382	1M10G7D	0.0297	1M09W7D
3	700.5 ~ 714.5	0.0378	2M72G7D	0.0299	2M71W7D
5	701.5 ~ 713.5	0.0378	4M50G7D	0.0297	4M51W7D
10	704.0 ~ 711.0	0.0389	9M01G7D	0.0304	9M05W7D
LTE Band 38		QPSK		16QAM/64QAM	
BW (MHz)	Frequency Range (MHz)	Maximum EIRP(W)	Emission Designator (99%OBW)	Maximum EIRP(W)	Emission Designator (99%OBW)
5	2572.5 ~ 2617.5	0.0824	4M53G7D	0.0697	4M49W7D
10	2575.0 ~ 2615.0	0.0834	9M03G7D	0.0682	9M05W7D
15	2577.5 ~ 2612.5	0.0843	13M5G7D	0.0693	13M5W7D
20	2580.0 ~ 2610.0	0.0859	17M9G7D	0.0693	17M9W7D
LTE Band 41		QPSK		16QAM/64QAM	
BW (MHz)	Frequency Range (MHz)	Maximum EIRP(W)	Emission Designator (99%OBW)	Maximum EIRP(W)	Emission Designator (99%OBW)
5	2498.5 ~ 2687.5	0.1409	4M53G7D	0.1094	4M49W7D
10	2501.0 ~ 2685.0	0.1409	9M03G7D	0.1119	9M05W7D
15	2503.5 ~ 2682.5	0.1413	13M5G7D	0.1074	13M5W7D
20	2506.0 ~ 2680.0	0.1439	17M9G7D	0.1114	17M9W7D

Note: LTE Band 41 overlaps the entire frequency range of LTE Band 38. Therefore, the test results provided in this report covers Band 41 as well as Band 38.



1.7 Testing Location

Sporton International Inc. (Kunshan) is accredited to ISO/IEC 17025:2017 by American Association for Laboratory Accreditation with Certificate Number 5145.02.

Test Firm	Sporton International Inc. (Kunshan)		
Test Site Location	No. 1098, Pengxi North Road, Kunshan Economic Development Zone Jiangsu Province 215300 People's Republic of China TEL : +86-512-57900158		
Test Site No.	Sporton Site No.	FCC Designation No.	FCC Test Firm Registration No.
	03CH04-KS TH01-KS	CN1257	314309

1.8 Test Software

Item	Site	Manufacture	Name	Version
1.	TH01-KS	SPORTON	FCC LTE_Ver2.0 Auto_china_210503	2.0
2.	03CH04-KS	AUDIX	E3	210616

1.9 Applicable Standards

According to the specifications of the manufacturer, the EUT must comply with the requirements of the following standards:

- ♦ 47 CFR Part 2, 22(H), 24(E), 27(L), 27(H), 27(M)
- ♦ ANSI C63.26-2015
- ♦ FCC KDB 971168 D01 Power Meas License Digital Systems v03r01
- ♦ FCC KDB 412172 D01 Determining ERP and EIRP v01r01

Remark:

1. All test items were verified and recorded according to the standards and without any deviation during the test.
2. This EUT has also been tested and complied with the requirements of FCC Part 15, Subpart B, recorded in a separate test report.



2 Test Configuration of Equipment Under Test

2.1 Test Mode

Antenna port conducted and radiated test items listed below are performed according to KDB 971168 D01 Power Meas License Digital Systems v03r01 with maximum output power.

Radiated measurements are performed by rotating the EUT in three different orthogonal test planes to find the maximum emission. (X/Y/Z Plane)

Test Items	Band	Bandwidth (MHz)						Modulation			RB #			Test Channel		
		1.4	3	5	10	15	20	QPSK	16 QAM	64 QAM	1	Half	Full	L	M	H
Max. Output Power	2	v	v	v	v	v	v	v	v	v	v		v	v	v	v
	4	v	v	v	v	v	v	v	v	v	v		v	v	v	v
	5	v	v	v	v	-	-	v	v	v	v		v	v	v	v
	7	-	-	v	v	v	v	v	v	v	v		v	v	v	v
	12	v	v	v	v	-	-	v	v	v	v		v	v	v	v
	38	-	-	v	v	v	v	v	v	v	v		v	v	v	v
	41	-	-	v	v	v	v	v	v	v	v		v	v	v	v
Peak-to-Average Ratio	2						v	v	v	v			v		v	
	4						v	v	v	v			v		v	
	5				v	-	-	v	v	v			v		v	
	7	-	-				v	v	v	v			v		v	
	12				v	-	-	v	v	v			v		v	
	41	-	-				v	v	v	v			v		v	
26dB and 99% Bandwidth	2	v	v	v	v	v	v	v	v				v		v	
	4	v	v	v	v	v	v	v	v				v		v	
	5	v	v	v	v	-	-	v	v				v		v	
	7	-	-	v	v	v	v	v	v				v		v	
	12	v	v	v	v	-	-	v	v				v		v	
	41	-	-	v	v	v	v	v	v				v		v	
Conducted Band Edge	2	v	v	v	v	v	v	v	v	v	v		v	v		v
	4	v	v	v	v	v	v	v	v	v	v		v	v		v
	5	v	v	v	v	-	-	v	v	v	v		v	v		v
	7	-	-	v	v	v	v	v	v	v	v		v	v		v
	12	v	v	v	v	-	-	v	v	v	v		v	v		v
	41	-	-	v	v	v	v	v	v	v	v		v	v		v



Test Items	Band	Bandwidth (MHz)						Modulation			RB #			Test Channel		
		1.4	3	5	10	15	20	QPSK	16QAM	64QAM	1	Half	Full	L	M	H
Conducted Spurious Emission	2	v	v	v	v	v	v	v			v			v	v	v
	4	v	v	v	v	v	v	v			v			v	v	v
	5	v	v	v	v	-	-	v			v			v	v	v
	7	-	-	v	v	v	v	v			v			v	v	v
	12	v	v	v	v	-	-	v			v			v	v	v
	41	-	-	v	v	v	v	v			v			v	v	v
Frequency Stability	2				v			v					v		v	
	4				v			v					v		v	
	5				v	-	-	v					v		v	
	7	-	-		v			v					v		v	
	12				v	-	-	v					v		v	
	41	-	-		v			v					v		v	
E.R.P / E.I.R.P	2	v	v	v	v	v	v	v	v	v	v		v	v	v	v
	4	v	v	v	v	v	v	v	v	v	v		v	v	v	v
	5	v	v	v	v	-	-	v	v	v	v		v	v	v	v
	7	-	-	v	v	v	v	v	v	v	v		v	v	v	v
	12	v	v	v	v	-	-	v	v	v	v		v	v	v	v
	38	-	-	v	v	v	v	v	v	v	v		v	v	v	v
	41	-	-	v	v	v	v	v	v	v	v		v	v	v	v
Radiated Spurious Emission	2	Worst Case													v	
	4	Worst Case													v	
	5	Worst Case													v	
	7	Worst Case													v	
	12	Worst Case													v	
	41	Worst Case													v	
Note	1. The mark "v" means that this configuration is chosen for testing 2. The mark "-" means that this bandwidth is not supported. 3. The device is investigated from 30MHz to 10 times of fundamental signal for radiated spurious emission test under different RB size/offset and modulations in exploratory test. Subsequently, only the worst case emissions are reported.															

2.2 Connection Diagram of Test System

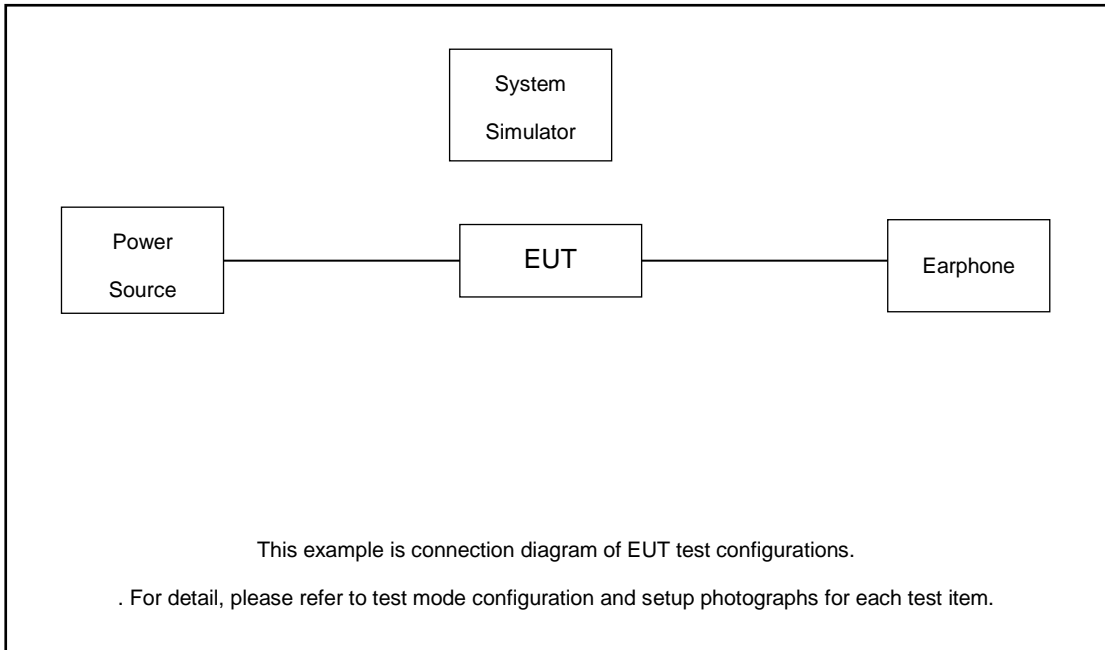

2.3 Support Unit used in test configuration and system

Item	Equipment	Trade Name	Model No.	FCC ID	Data Cable	Power Cord
1.	Power Supply	GWINSTEK	PSS-2002	N/A	N/A	Unshielded, 1.8 m
2.	LTE Base Station	Anritsu	MT8820C	N/A	N/A	Unshielded, 1.8 m
3.	Earphone	N/A	N/A	N/A	N/A	N/A

2.4 Measurement Results Explanation Example

For all conducted test items:

The offset level is set in the spectrum analyzer to compensate the RF cable loss between EUT conducted output port and spectrum analyzer. With the offset compensation, the spectrum analyzer reading level is exactly the EUT RF output level.

The spectrum analyzer offset is derived from RF cable loss.

Offset = RF cable loss.

Following shows an offset computation example with cable loss 5.8 dB.

Example :

$$\begin{aligned} \text{Offset(dB)} &= \text{RF cable loss(dB)} + \text{attenuator factor(dB)}. \\ &= 5.8 \text{ (dB)} \end{aligned}$$



2.5 Frequency List of Low/Middle/High Channels

LTE Band 2 Channel and Frequency List				
BW [MHz]	Channel/Frequency(MHz)	Lowest	Middle	Highest
20	Channel	18700	18900	19100
	Frequency	1860	1880	1900
15	Channel	18675	18900	19125
	Frequency	1857.5	1880	1902.5
10	Channel	18650	18900	19150
	Frequency	1855	1880	1905
5	Channel	18625	18900	19175
	Frequency	1852.5	1880	1907.5
3	Channel	18615	18900	19185
	Frequency	1851.5	1880	1908.5
1.4	Channel	18607	18900	19193
	Frequency	1850.7	1880	1909.3

LTE Band 4 Channel and Frequency List				
BW [MHz]	Channel/Frequency(MHz)	Lowest	Middle	Highest
20	Channel	20050	20175	20300
	Frequency	1720	1732.5	1745
15	Channel	20025	20175	20325
	Frequency	1717.5	1732.5	1747.5
10	Channel	20000	20175	20350
	Frequency	1715	1732.5	1750
5	Channel	19975	20175	20375
	Frequency	1712.5	1732.5	1752.5
3	Channel	19965	20175	20385
	Frequency	1711.5	1732.5	1753.5
1.4	Channel	19957	20175	20393
	Frequency	1710.7	1732.5	1754.3



LTE Band 5 Channel and Frequency List				
BW [MHz]	Channel/Frequency(MHz)	Lowest	Middle	Highest
10	Channel	20450	20525	20600
	Frequency	829	836.5	844
5	Channel	20425	20525	20625
	Frequency	826.5	836.5	846.5
3	Channel	20415	20525	20635
	Frequency	825.5	836.5	847.5
1.4	Channel	20407	20525	20643
	Frequency	824.7	836.5	848.3

LTE Band 7 Channel and Frequency List				
BW [MHz]	Channel/Frequency(MHz)	Lowest	Middle	Highest
20	Channel	20850	21100	21350
	Frequency	2510	2535	2560
15	Channel	20825	21100	21375
	Frequency	2507.5	2535	2562.5
10	Channel	20800	21100	21400
	Frequency	2505	2535	2565
5	Channel	20775	21100	21425
	Frequency	2502.5	2535	2567.5

LTE Band 12 Channel and Frequency List				
BW [MHz]	Channel/Frequency(MHz)	Lowest	Middle	Highest
10	Channel	23060	23095	23130
	Frequency	704	707.5	711
5	Channel	23035	23095	23155
	Frequency	701.5	707.5	713.5
3	Channel	23025	23095	23165
	Frequency	700.5	707.5	714.5
1.4	Channel	23017	23095	23173
	Frequency	699.7	707.5	715.3



LTE Band 38 Channel and Frequency List				
BW [MHz]	Channel/Frequency(MHz)	Lowest	Middle	Highest
20	Channel	37850	38000	38150
	Frequency	2580	2595	2610
15	Channel	37825	38000	38175
	Frequency	2577.5	2595	2612.5
10	Channel	37800	38000	38200
	Frequency	2575	2595	2615
5	Channel	37775	38000	38225
	Frequency	2572.5	2595	2617.5

LTE Band 41 Channel and Frequency List				
BW [MHz]	Channel/Frequency(MHz)	Lowest	Middle	Highest
20	Channel	39750	40620	41490
	Frequency	2506	2593	2680
15	Channel	39725	40620	41515
	Frequency	2503.5	2593	2682.5
10	Channel	39700	40620	41540
	Frequency	2501	2593	2685
5	Channel	39675	40620	41565
	Frequency	2498.5	2593	2687.5

3 Conducted Test Items

3.1 Measuring Instruments

See list of measuring instruments of this test report.

3.2 Test Setup

3.2.1 Conducted Output Power



3.2.2 Peak-to-Average Ratio, Occupied Bandwidth ,Conducted Band-Edge and Conducted Spurious Emission



3.2.3 Frequency Stability

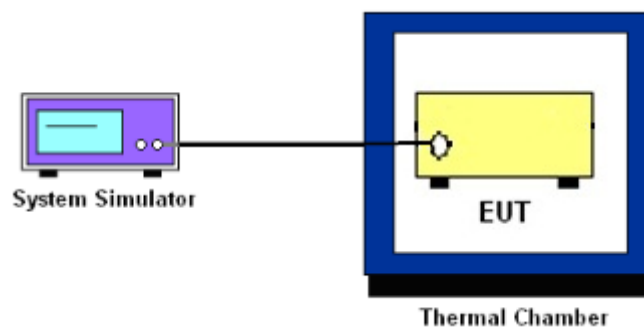

3.3 Test Result of Conducted Test

Please refer to Appendix A.



3.4 Conducted Output Power and ERP/EIRP

3.4.1 Description of the Conducted Output Power Measurement and ERP/EIRP Measurement

A system simulator was used to establish communication with the EUT. Its parameters were set to force the EUT transmitting at maximum output power. The measured power in the radio frequency on the transmitter output terminals shall be reported.

The ERP of mobile transmitters must not exceed 7 Watts for LTE Band 5.

The ERP of mobile transmitters must not exceed 3 Watts for LTE Band 12.

The EIRP of mobile transmitters must not exceed 2 Watts for LTE Band 2 and Band 7 and Band 38 and Band 41.

The EIRP of mobile transmitters must not exceed 1 Watts for LTE Band 4.

According to KDB 412172 D01 Power Approach,

$EIRP = P_T + G_T - L_C$, $ERP = EIRP - 2.15$, where

P_T = transmitter output power in dBm

G_T = gain of the transmitting antenna in dBi

L_C = signal attenuation in the connecting cable between the transmitter and antenna in dB

3.4.2 Test Procedures

1. The testing follows ANSI C63.26 Section 5.2
2. The transmitter output port was connected to the system simulator.
3. Set EUT at maximum power through the system simulator.
4. Select lowest, middle, and highest channels for each band and different modulation.
5. Measure and record the power level from the system simulator.



3.5 Peak-to-Average Ratio

3.5.1 Description of the PAR Measurement

Power Complementary Cumulative Distribution Function (CCDF) curves provide a means for characterizing the power peaks of a digitally modulated signal on a statistical basis. A CCDF curve depicts the probability of the peak signal amplitude exceeding the average power level. Most contemporary measurement instrumentation include the capability to produce CCDF curves for an input signal provided that the instrument's resolution bandwidth can be set wide enough to accommodate the entire input signal bandwidth. In measuring transmissions in this band using an average power technique, the peak-to-average ratio (PAR) of the transmission may not exceed 13 dB.

3.5.2 Test Procedures

1. The testing follows ANSI C63.26 Section 5.2.3.4 (CCDF).
2. The EUT was connected to spectrum and system simulator via a power divider.
3. Set the CCDF (Complementary Cumulative Distribution Function) option in spectrum analyzer.
4. The highest RF powers were measured and recorded the maximum PAPR level associated with a probability of 0.1 %.
5. Record the deviation as Peak to Average Ratio.



3.6 Occupied Bandwidth

3.6.1 Description of Occupied Bandwidth Measurement

The occupied bandwidth is the width of a frequency band such that, below the lower and above the upper frequency limits, the mean powers emitted are each equal to a specified percentage 0.5% of the total mean transmitted power.

The 26 dB emission bandwidth is defined as the frequency range between two points, one above and one below the carrier frequency, at which the spectral density of the emission is attenuated 26 dB below the maximum in-band spectral density of the modulated signal. Spectral density (power per unit bandwidth) is to be measured with a detector of resolution bandwidth equal to approximately 1.0% of the emission bandwidth.

3.6.2 Test Procedures

1. The testing follows ANSI C63.26 Section 5.4
2. The EUT was connected to spectrum analyzer and system simulator via a power divider.
3. The spectrum analyzer center frequency is set to the nominal EUT channel center frequency. The span range for the spectrum analyzer shall be between two and five times the anticipated OBW.
4. The nominal resolution bandwidth (RBW) shall be in the range of 1 to 5 % of the anticipated OBW, and the VBW shall be at least 3 times the RBW.
5. Set the detection mode to peak, and the trace mode to max hold.
6. Determine the reference value: Set the EUT to transmit a modulated signal. Allow the trace to stabilize. Set the spectrum analyzer marker to the highest level of the displayed trace.
(this is the reference value)
7. Determine the “-26 dB down amplitude” as equal to (Reference Value – X).
8. Place two markers, one at the lowest and the other at the highest frequency of the envelope of the spectral display such that each marker is at or slightly below the “-X dB down amplitude” determined in step 6. If a marker is below this “-X dB down amplitude” value it shall be placed as close as possible to this value. The OBW is the positive frequency difference between the two markers.
9. Use the 99 % power bandwidth function of the spectrum analyzer and report the measured bandwidth.



3.7 Conducted Band Edge

3.7.1 Description of Conducted Band Edge Measurement

22.917(a)

For operations in the 824 – 849 MHz band, the FCC limit is $43 + 10\log_{10}(P[\text{Watts}])$ dB below the transmitter power $P(\text{Watts})$ in a 100kHz bandwidth. However, in the 1MHz bands immediately outside and adjacent to the licensee's frequency block, a resolution bandwidth of at least one percent of the emission bandwidth of the fundamental emission of the transmitter may be employed.

24.238 (a)

For operations in the 1850-1910 and 1930-1990 MHz band, the FCC limit is $43 + 10\log_{10}(P[\text{Watts}])$ dB below the transmitter power $P(\text{Watts})$ in a 1MHz bandwidth. However, in the 1 MHz bands immediately outside and adjacent to the frequency block a resolution bandwidth of at least one percent of the emission bandwidth of the fundamental emission of the transmitter may be employed.

27.53 (g)

For operations in the 600MHz band and 698 -746 MHz band, the FCC limit is $43 + 10\log_{10}(P[\text{Watts}])$ dB below the transmitter power $P(\text{Watts})$ in a 100 kHz bandwidth. However, in the 100 kilohertz bands immediately outside and adjacent to a licensee's frequency block, a resolution bandwidth of at least 30 kHz may be employed.

27.53 (h)

For operations in the 1710 – 1755 MHz band, the FCC limit is $43 + 10\log_{10}(P[\text{Watts}])$ dB below the transmitter power $P(\text{Watts})$ in a 1 MHz bandwidth. However, in the 1MHz bands immediately outside and adjacent to the licensee's frequency block, a resolution bandwidth of at least one percent of the emission bandwidth of the fundamental emission of the transmitter may be employed.



27.53(m)(4)

For mobile digital stations, the attenuation factor shall be not less than $40 + 10 \log (P)$ dB on all frequencies between the channel edge and 5 megahertz from the channel edge, $43 + 10 \log (P)$ dB on all frequencies between 5 megahertz and X megahertz from the channel edge, and $55 + 10 \log (P)$ dB on all frequencies more than X megahertz from the channel edge, where X is the greater of 6 megahertz or the actual emission bandwidth as defined in paragraph (m)(6) of this section. In addition, the attenuation factor shall not be less that $43 + 10 \log (P)$ dB on all frequencies between 2490.5 MHz and 2496 MHz and $55 + 10 \log (P)$ dB at or below 2490.5 MHz. Mobile Satellite Service licensees operating on frequencies below 2495 MHz may also submit a documented interference complaint against BRS licensees operating on channel BRS Channel 1 on the same terms and conditions as adjacent channel BRS or EBS licensees.

3.7.2 Test Procedures

1. The testing follows ANSI C63.26 section 5.7
2. The EUT was connected to spectrum analyzer and system simulator via a power divider.
3. The band edges of low and high channels for the highest RF powers were measured.
4. Set RBW $\geq 1\%$ EBW in the 1MHz band immediately outside and adjacent to the band edge.
5. Beyond the 1 MHz band from the band edge, RBW=1MHz was used or a narrower RBW was used and the measured power was integrated over the full required measurement bandwidth of 1 MHz.
6. Set spectrum analyzer with RMS detector.
7. The RF fundamental frequency should be excluded against the limit line in the operating frequency band.
8. Checked that all the results comply with the emission limit line.

Example:

The limit line is derived from $43 + 10\log(P)$ dB below the transmitter power P(Watts)
= $P(W) - [43 + 10\log(P)]$ (dB)
= $[30 + 10\log(P)]$ (dBm) - $[43 + 10\log(P)]$ (dB) = -13dBm.

9. When using the integration method, the starting frequency of the integration shall be centered at one-half of the RBW away from the band edge.



3.8 Conducted Spurious Emission

3.8.1 Description of Conducted Spurious Emission Measurement

The power of any emission outside of the authorized operating frequency ranges must be lower than the transmitter power (P) by a factor of at least $43 + 10 \log (P)$ dB.

For Band 7,38,41:

The power of any emission outside of the authorized operating frequency ranges must be lower than the transmitter power (P) by a factor of at least $55 + 10 \log (P)$ dB.

It is measured by means of a calibrated spectrum analyzer and scanned from 30 MHz up to a frequency including its 10th harmonic.

3.8.2 Test Procedures

1. The testing follows ANSI C63.26 section 5.7
2. The EUT was connected to spectrum analyzer and system simulator via a power divider.
3. The RF output of EUT was connected to the spectrum analyzer by RF cable and attenuator. The path loss was compensated to the results for each measurement.
4. The middle channel for the highest RF power within the transmitting frequency was measured.
5. The conducted spurious emission for the whole frequency range was taken.
6. Make the measurement with the spectrum analyzer's RBW = 1MHz, VBW = 3MHz.
7. Set spectrum analyzer with RMS detector.
8. Taking the record of maximum spurious emission.
9. The RF fundamental frequency should be excluded against the limit line in the operating frequency band.
10. The limit line is derived from $43 + 10\log(P)$ dB below the transmitter power P(Watts)
= $P(W) - [43 + 10\log(P)]$ (dB)
= $[30 + 10\log(P)]$ (dBm) - $[43 + 10\log(P)]$ (dB)
= -13dBm.
11. For Band 7, 38, 41
The limit line is derived from $55 + 10\log(P)$ dB below the transmitter power P(Watts)
= $P(W) - [55 + 10\log(P)]$ (dB)
= $[30 + 10\log(P)]$ (dBm) - $[55 + 10\log(P)]$ (dB)
= -25dBm.



3.9 Frequency Stability

3.9.1 Description of Frequency Stability Measurement

The frequency stability shall be measured by variation of ambient temperature and variation of primary supply voltage to ensure that the fundamental emission stays within the authorized frequency block. The frequency stability of the transmitter shall be maintained within $\pm 0.00025\%$ ($\pm 2.5\text{ppm}$) of the center frequency.

3.9.2 Test Procedures for Temperature Variation

1. The testing follows ANSI C63.26 section 5.6.4
2. The EUT was set up in the thermal chamber and connected with the system simulator.
3. With power OFF, the temperature was decreased to -30°C and the EUT was stabilized before testing. Power was applied and the maximum change in frequency was recorded within one minute.
4. With power OFF, the temperature was raised in 10°C step up to 50°C . The EUT was stabilized at each step for at least half an hour. Power was applied and the maximum frequency change was recorded within one minute.

3.9.3 Test Procedures for Voltage Variation

1. The testing follows ANSI C63.26 section 5.6.5
2. The EUT was placed in a temperature chamber at $20\pm 5^{\circ}\text{C}$ and connected with the system simulator.
3. The power supply voltage to the EUT was varied from 85% to 115% of the nominal value for other than hand carried battery equipment.
4. For hand carried, battery powered equipment, reduce the primary ac or dc supply voltage to the battery operating end point, which shall be specified by the manufacturer.
5. The variation in frequency was measured for the worst case.

4 Radiated Test Items

4.1 Measuring Instruments

See list of measuring instruments of this test report.

4.2 Test Setup

4.2.1 For radiated test below 30MHz

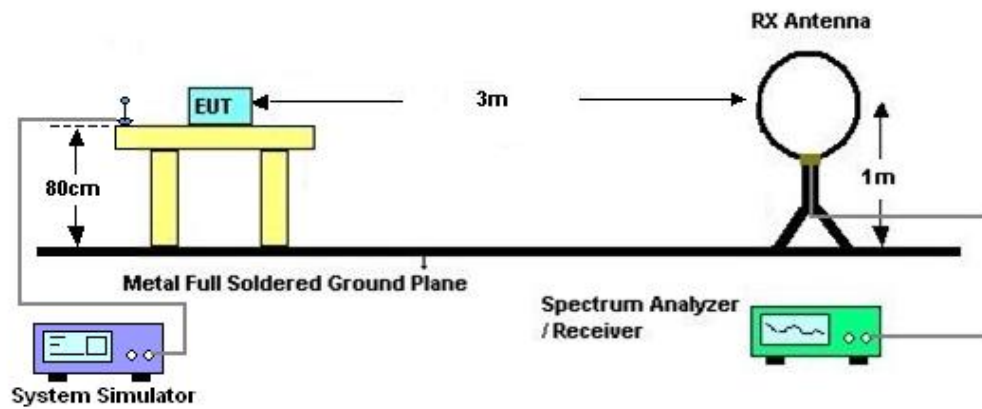

4.2.2 For radiated test from 30MHz to 1GHz

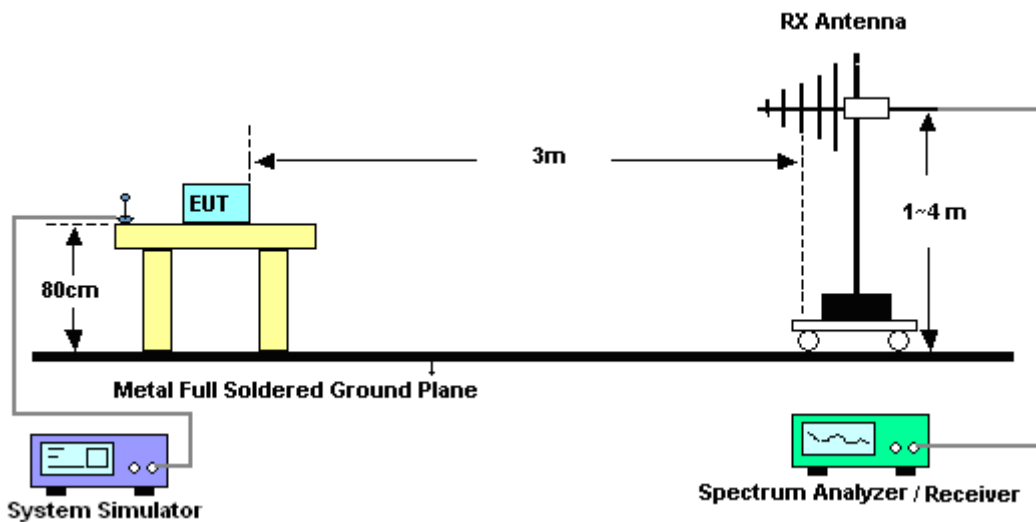

4.2.3 For radiated test above 1GHz

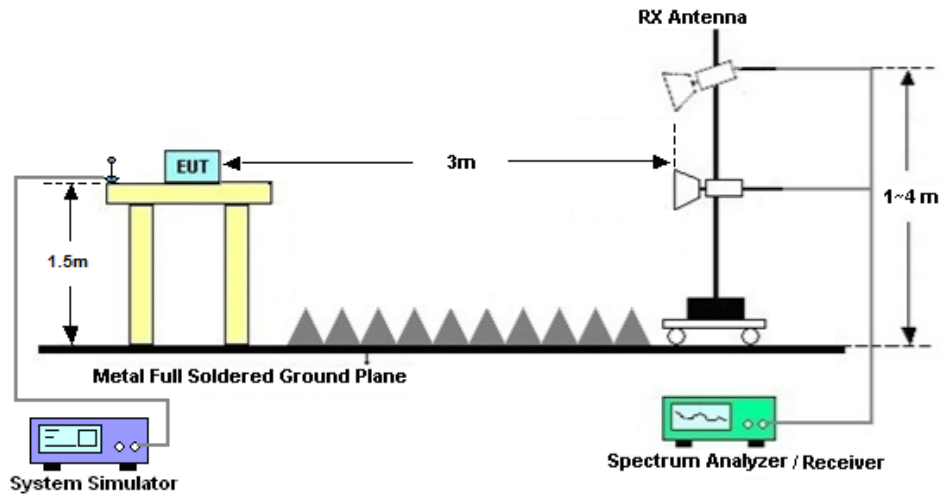

4.3 Test Result of Radiated Test

The low frequency, which started from 9 kHz to 30MHz, was pre-scanned and the result which was 20dB lower than the limit line was not reported.

Please refer to Appendix B.



4.4 Radiated Spurious Emission

4.4.1 Description of Radiated Spurious Emission

The radiated spurious emission was measured by substitution method according to ANSI C63.26. The power of any emission outside of the authorized operating frequency ranges must be attenuated below the transmitter power (P) by a factor of at least $43 + 10 \log (P)$ dB.

For Band 7, 38, 41

The power of any emission outside of the authorized operating frequency ranges must be attenuated below the transmitter power (P) by a factor of at least $55 + 10 \log (P)$ dB.

The spectrum is scanned from 30 MHz up to a frequency including its 10th harmonic.

4.4.2 Test Procedures

1. The testing follows ANSI C63.26 Section 5.5
2. The EUT was placed on a turntable with 0.8 meter height for frequency below 1GHz and 1.5 meter height for frequency above 1GHz respectively above ground.
3. The EUT was set 3 meters from the receiving antenna mounted on the antenna tower.
4. The table was rotated 360 degrees to determine the position of the highest spurious emission.
5. The height of the receiving antenna is varied between 1m to 4m to search the maximum spurious emission for both horizontal and vertical polarizations.
6. During the measurement, the system simulator parameters were set to force the EUT transmitting at maximum output power.
7. Make the measurement with the spectrum analyzer's RBW = 1MHz, VBW = 3MHz, taking the record of maximum spurious emission.
8. A horn antenna was substituted in place of the EUT and was driven by a signal generator.
9. Tune the output power of signal generator to the same emission level with EUT maximum spurious emission.
10. $EIRP (dBm) = S.G. Power - Tx Cable Loss + Tx Antenna Gain$
11. $ERP (dBm) = EIRP - 2.15$
12. The RF fundamental frequency should be excluded against the limit line in the operating frequency band.

The limit line is derived from $43 + 10\log(P)$ dB below the transmitter power P(Watts)
 $= P(W) - [43 + 10\log(P)] (dB)$
 $= [30 + 10\log(P)] (dBm) - [43 + 10\log(P)] (dB)$
 $= -13dBm.$



5 List of Measuring Equipment

Instrument	Manufacturer	Model No.	Serial No.	Characteristics	Calibration Date	Test Date	Due Date	Remark
Spectrum Analyzer	R&S	FSV40	101040	10Hz~40GHz	Oct. 11, 2023	Feb. 25, 2024~ Mar. 27, 2024	Oct. 10, 2024	Conducted (TH01-KS)
Power divider	STI	STI08-0055	-	0.5~40GHz	NCR	Feb. 25, 2024~ Mar. 27, 2024	NCR	Conducted (TH01-KS)
Temperature & humidity chamber	Hongzhan	LP-150U	H2014011440	-40~+150°C 20%~95%RH	Jul. 06, 2023	Feb. 25, 2024~ Mar. 27, 2024	Jul. 05, 2024	Conducted (TH01-KS)
EXA Spectrum Analyzer	Keysight	N9010B	MY57471079	10Hz~44G,MAX 30dB	Oct. 10, 2023	Apr. 07, 2024	Oct. 09, 2024	Radiation (03CH04-KS)
Loop Antenna	R&S	HFH2-Z2E	101125	9kHz~30MHz	Sep. 11 2023	Apr. 07, 2024	Sep. 10, 2024	Radiation (03CH04-KS)
Bilog Antenna	TeseQ	CBL6111D	49922	30MHz-1GHz	Apr. 09, 2023	Apr. 07, 2024	Apr. 08, 2024	Radiation (03CH04-KS)
Double Ridge Horn Antenna	ETS-Lindgren	3117	00251694	1GHz~18GHz	Jul. 12, 2023	Apr. 07, 2024	Jul. 11, 2024	Radiation (03CH04-KS)
SHF-EHF Horn	Com-power	AH-840	101070	18GHz~40GHz	Jan. 05, 2024	Apr. 07, 2024	Jan. 04, 2025	Radiation (03CH04-KS)
Amplifier	SONOMA	310N	380827	9KHz-1GHz	Jul. 06, 2023	Apr. 07, 2024	Jul. 05, 2024	Radiation (03CH04-KS)
Amplifier	MITEQ	EM18G40G GA	060728	18~40GHz	Jan. 05, 2024	Apr. 07, 2024	Jan. 04, 2025	Radiation (03CH04-KS)
high gain Amplifier	EM	EM01G18G A	060840	1Ghz-18Ghz	Oct. 10, 2023	Apr. 07, 2024	Oct. 09, 2024	Radiation (03CH04-KS)
Amplifier	Agilent	8449B	3008A02370	1Ghz-18Ghz	Oct. 10, 2023	Apr. 07, 2024	Oct. 09, 2024	Radiation (03CH04-KS)
AC Power Source	Chroma	61601	F104090004	N/A	NCR	Apr. 07, 2024	NCR	Radiation (03CH04-KS)
Turn Table	ChamPro	EM 1000-T	060762-T	0~360 degree	NCR	Apr. 07, 2024	NCR	Radiation (03CH04-KS)
Antenna Mast	ChamPro	EM 1000-A	060762-A	1 m~4 m	NCR	Apr. 07, 2024	NCR	Radiation (03CH04-KS)

NCR: No Calibration Required.



6 Measurement Uncertainty

The measurement uncertainties shown below were calculated in accordance with the requirements of ANSI 63.26-2015. All the measurement uncertainty value were shown with a coverage K=2 to indicate 95% level of confidence. The measurement data show herein meets or exceeds the CISPR measurement uncertainty values specified in CISPR 16-4-2 and can be compared directly to specified limit to determine compliance.

Uncertainty of Conducted Measurement

Test Item	Uncertainty
Conducted Spurious Emission & Bandedge	±2.26 dB
Occupied Channel Bandwidth	±0.1%
Conducted Power	±0.46 dB
Peak to Average Ratio	±0.46 dB
Frequency Stability	±0.4 Hz

Uncertainty of Radiated Emission Measurement (30 MHz ~ 1000 MHz)

Measuring Uncertainty for a Level of Confidence of 95% (U = 2Uc(y))	3.82 dB
---	---------

Uncertainty of Radiated Emission Measurement (1 GHz ~ 18 GHz)

Measuring Uncertainty for a Level of Confidence of 95% (U = 2Uc(y))	3.56 dB
---	---------

Uncertainty of Radiated Emission Measurement (18 GHz ~ 40 GHz)

Measuring Uncertainty for a Level of Confidence of 95% (U = 2Uc(y))	3.54 dB
---	---------

----- THE END -----



Appendix A. Test Results of Conducted Test

Test Engineer :	Simle Wang	Temperature :	22~23°C
		Relative Humidity :	40~42%

Conducted Output Power(Average power) and ERP/EIEP

LTE Band 2_ANT 4:

BW [MHz]	Modulation	RB Size	RB Offset	Power Low Ch. / Freq.	Power Middle Ch. / Freq.	Power High Ch. / Freq.	EIRP(W)		
Channel				18700	18900	19100			
Frequency (MHz)				1860	1880	1900	L	M	H
20	QPSK	1	0	22.47	22.51	22.42	0.0826	0.0834	0.0817
20	QPSK	1	99	22.43	22.49	22.38	0.0818	0.0830	0.0809
20	QPSK	100	0	21.37	21.50	21.40	0.0641	0.0661	0.0646
20	16QAM	1	0	21.37	21.46	21.38	0.0641	0.0655	0.0643
20	64QAM	1	0	20.69	20.83	20.77	0.0548	0.0566	0.0558
Channel				18675	18900	19125	EIRP(W)		
Frequency (MHz)				1857.5	1880	1902.5	L	M	H
15	QPSK	1	0	22.39	22.48	22.29	0.0811	0.0828	0.0793
15	16QAM	1	0	21.33	21.29	21.26	0.0635	0.0630	0.0625
Channel				18650	18900	19150	EIRP(W)		
Frequency (MHz)				1855	1880	1905	L	M	H
10	QPSK	1	0	22.43	22.46	22.27	0.0818	0.0824	0.0789
10	16QAM	1	0	21.29	21.40	21.25	0.0630	0.0646	0.0624
Channel				18625	18900	19175	EIRP(W)		
Frequency (MHz)				1852.5	1880	1907.5	L	M	H
5	QPSK	1	0	22.41	22.43	22.26	0.0815	0.0818	0.0787
5	16QAM	1	0	21.34	21.41	21.21	0.0637	0.0647	0.0618
Channel				18615	18900	19185	EIRP(W)		
Frequency (MHz)				1851.5	1880	1908.5	L	M	H
3	QPSK	1	0	22.43	22.46	22.29	0.0818	0.0824	0.0793
3	16QAM	1	0	21.29	21.38	21.25	0.0630	0.0643	0.0624
Channel				18607	18900	19193	EIRP(W)		
Frequency (MHz)				1850.7	1880	1909.3	L	M	H
1.4	QPSK	1	0	22.37	22.34	22.24	0.0807	0.0802	0.0783
1.4	16QAM	1	0	21.15	21.33	21.09	0.0610	0.0635	0.0601



LTE Band 4_ANT 1:

BW [MHz]	Modulation	RB Size	RB Offset	Power Low Ch. / Freq.	Power Middle Ch. / Freq.	Power High Ch. / Freq.	EIRP(W)		
Channel				20050	20175	20300	EIRP(W)		
Frequency (MHz)				1720	1732.5	1745	L	M	H
20	QPSK	1	0	22.47	22.63	22.55	0.0807	0.0838	0.0822
20	QPSK	1	99	22.37	22.58	22.56	0.0789	0.0828	0.0824
20	QPSK	100	0	21.37	21.58	21.50	0.0627	0.0658	0.0646
20	16QAM	1	0	21.34	21.51	21.53	0.0622	0.0647	0.0650
20	64QAM	1	0	20.54	20.52	20.55	0.0518	0.0515	0.0519
Channel				20025	20175	20325	EIRP(W)		
Frequency (MHz)				1717.5	1732.5	1747.5	L	M	H
15	QPSK	1	0	22.40	22.54	22.46	0.0794	0.0820	0.0805
15	16QAM	1	0	21.29	21.38	21.50	0.0615	0.0628	0.0646
Channel				20000	20175	20350	EIRP(W)		
Frequency (MHz)				1715	1732.5	1750	L	M	H
10	QPSK	1	0	22.28	22.58	22.57	0.0773	0.0828	0.0826
10	16QAM	1	0	21.19	21.42	21.33	0.0601	0.0634	0.0621
Channel				19975	20175	20375	EIRP(W)		
Frequency (MHz)				1712.5	1732.5	1752.5	L	M	H
5	QPSK	1	0	22.36	22.45	22.44	0.0787	0.0804	0.0802
5	16QAM	1	0	21.17	21.42	21.40	0.0598	0.0634	0.0631
Channel				19965	20175	20385	EIRP(W)		
Frequency (MHz)				1711.5	1732.5	1753.5	L	M	H
3	QPSK	1	0	22.25	22.54	22.50	0.0767	0.0820	0.0813
3	16QAM	1	0	21.18	21.49	21.39	0.0600	0.0644	0.0630
Channel				19950	20175	20393	EIRP(W)		
Frequency (MHz)				1710	1732.5	1754.3	L	M	H
1.4	QPSK	1	0	22.26	22.49	22.38	0.0769	0.0811	0.0791
1.4	16QAM	1	0	21.32	21.43	21.42	0.0619	0.0635	0.0634



LTE Band 5_ANT 4:

BW [MHz]	Modulation	RB Size	RB Offset	Power Low Ch. / Freq.	Power Middle Ch. / Freq.	Power High Ch. / Freq.	ERP(W)		
Channel				20450	20525	20600	ERP(W)		
Frequency (MHz)				829	836.5	844	L	M	H
10	QPSK	1	0	22.86	22.97	22.60	0.0418	0.0429	0.0394
10	QPSK	1	49	22.71	22.82	22.69	0.0404	0.0414	0.0402
10	QPSK	50	0	21.79	21.88	21.75	0.0327	0.0333	0.0324
10	16QAM	1	0	21.83	21.96	21.82	0.0330	0.0340	0.0329
10	64QAM	1	0	21.09	21.23	21.13	0.0278	0.0287	0.0281
Channel				20425	20525	20625	ERP(W)		
Frequency (MHz)				826.5	836.5	846.5	L	M	H
5	QPSK	1	0	22.77	22.84	22.51	0.0409	0.0416	0.0385
5	16QAM	1	0	21.70	21.85	21.67	0.0320	0.0331	0.0318
Channel				20415	20525	20635	ERP(W)		
Frequency (MHz)				825.5	836.5	847.5	L	M	H
3	QPSK	1	0	22.80	22.87	22.52	0.0412	0.0419	0.0386
3	16QAM	1	0	21.69	21.82	21.75	0.0319	0.0329	0.0324
Channel				20407	20525	20643	ERP(W)		
Frequency (MHz)				824.7	836.5	848.3	L	M	H
1.4	QPSK	1	0	22.78	22.82	22.48	0.0410	0.0414	0.0383
1.4	16QAM	1	0	21.55	21.64	21.54	0.0309	0.0316	0.0308



LTE Band 7_ANT 1:

BW [MHz]	Modulation	RB Size	RB Offset	Power Low Ch. / Freq.	Power Middle Ch. / Freq.	Power High Ch. / Freq.	EIRP(W)		
Channel				20850	20850	21350	EIRP(W)		
Frequency (MHz)				2510	2535	2560	L	M	H
20	QPSK	1	0	22.40	22.53	22.49	0.0912	0.0940	0.0931
20	QPSK	1	99	22.20	22.38	22.37	0.0871	0.0908	0.0906
20	QPSK	100	0	21.52	21.55	21.42	0.0745	0.0750	0.0728
20	16QAM	1	0	21.48	21.41	21.62	0.0738	0.0726	0.0762
20	64QAM	1	0	20.53	20.59	20.47	0.0593	0.0601	0.0585
Channel				20825	21100	21375	EIRP(W)		
Frequency (MHz)				2507.5	2535	2562.5	L	M	H
15	QPSK	1	0	22.41	22.39	22.47	0.0914	0.0910	0.0927
15	16QAM	1	0	21.39	21.34	21.56	0.0723	0.0714	0.0752
Channel				20800	21100	21400	EIRP(W)		
Frequency (MHz)				2505	2535	2565	L	M	H
10	QPSK	1	0	22.33	22.45	22.43	0.0897	0.0923	0.0918
10	16QAM	1	0	21.35	21.25	21.50	0.0716	0.0700	0.0741
Channel				20775	21100	21425	EIRP(W)		
Frequency (MHz)				2502.5	2535	2567.5	L	M	H
5	QPSK	1	0	22.34	22.46	22.48	0.0899	0.0925	0.0929
5	16QAM	1	0	21.47	21.34	21.55	0.0736	0.0714	0.0750



LTE Band 12_ANT 4:

BW [MHz]	Modulation	RB Size	RB Offset	Power Low Ch. / Freq.	Power Middle Ch. / Freq.	Power High Ch. / Freq.	ERP(W)		
Channel				23060	23095	23130	ERP(W)		
Frequency (MHz)				704	707.5	711	L	M	H
10	QPSK	1	0	22.79	22.95	22.87	0.0375	0.0389	0.0382
10	QPSK	1	49	22.71	22.84	22.70	0.0368	0.0379	0.0367
10	QPSK	50	0	21.77	21.91	21.76	0.0296	0.0306	0.0296
10	16QAM	1	0	21.82	21.88	21.76	0.0300	0.0304	0.0296
10	64QAM	1	0	21.30	21.41	21.31	0.0266	0.0273	0.0267
Channel				23035	23095	23155	ERP(W)		
Frequency (MHz)				701.5	707.5	713.5	L	M	H
5	QPSK	1	0	22.64	22.82	22.75	0.0362	0.0378	0.0372
5	16QAM	1	0	21.67	21.78	21.70	0.0290	0.0297	0.0292
Channel				23025	23095	23165	ERP(W)		
Frequency (MHz)				700.5	707.5	714.5	L	M	H
3	QPSK	1	0	22.73	22.82	22.78	0.0370	0.0378	0.0374
3	16QAM	1	0	21.69	21.80	21.68	0.0291	0.0299	0.0290
Channel				23017	23095	23173	ERP(W)		
Frequency (MHz)				699.7	707.5	715.3	L	M	H
1.4	QPSK	1	0	22.66	22.87	22.74	0.0364	0.0382	0.0371
1.4	16QAM	1	0	21.76	21.78	21.58	0.0296	0.0297	0.0284



LTE Band 38_ANT 1:

BW [MHz]	Modulation	RB Size	RB Offset	Power Low Ch. / Freq.	Power Middle Ch. / Freq.	Power High Ch. / Freq.	EIRP(W)		
Channel				37850	38000	38150	EIRP(W)		
Frequency (MHz)				2580	2595	2610	L	M	H
20	QPSK	1	0	22.39	22.54	22.51	0.0830	0.0859	0.0853
20	QPSK	1	99	22.19	22.50	22.39	0.0793	0.0851	0.0830
20	QPSK	100	0	21.47	21.54	21.45	0.0671	0.0682	0.0668
20	16QAM	1	0	21.50	21.54	21.61	0.0676	0.0682	0.0693
20	64QAM	1	0	20.59	20.43	20.56	0.0548	0.0528	0.0545
Channel				37825	38000	38175	EIRP(W)		
Frequency (MHz)				2577.5	2595	2612.5	L	M	H
15	QPSK	1	0	22.34	22.46	22.44	0.0820	0.0843	0.0839
15	16QAM	1	0	21.42	21.34	21.61	0.0664	0.0652	0.0693
Channel				37800	38000	38200	EIRP(W)		
Frequency (MHz)				2575	2595	2615	L	M	H
10	QPSK	1	0	22.26	22.41	22.40	0.0805	0.0834	0.0832
10	16QAM	1	0	21.37	21.51	21.54	0.0656	0.0678	0.0682
Channel				37775	38000	38225	EIRP(W)		
Frequency (MHz)				2572.5	2595	2617.5	L	M	H
5	QPSK	1	0	22.29	22.36	22.33	0.0811	0.0824	0.0818
5	16QAM	1	0	21.49	21.44	21.63	0.0675	0.0667	0.0697

LTE Band 41_ANT 1:

BW [MHz]	Modulation	RB Size	RB Offset	Power Low Ch. / Freq.	Power Middle Ch. / Freq.	Power High Ch. / Freq.	EIRP(W)		
Channel				39750	40620	41490	EIRP(W)		
Frequency (MHz)				2506	2593	2680	L	M	H
20	QPSK	1	0	24.67	24.78	24.75	0.1403	0.1439	0.1429
20	QPSK	1	99	24.57	24.63	24.65	0.1371	0.1390	0.1396
20	QPSK	100	0	23.60	23.73	23.58	0.1096	0.1130	0.1091
20	16QAM	1	0	23.51	23.62	23.67	0.1074	0.1102	0.1114
20	64QAM	1	0	22.55	22.67	22.65	0.0861	0.0885	0.0881
Channel				39725	40620	41515	EIRP(W)		
Frequency (MHz)				2503.5	2593	2682.5	L	M	H
15	QPSK	1	0	24.60	24.70	24.57	0.1380	0.1413	0.1371
15	16QAM	1	0	23.35	23.40	23.51	0.1035	0.1047	0.1074
Channel				39700	40620	41540	EIRP(W)		
Frequency (MHz)				2501	2593	2685	L	M	H
10	QPSK	1	0	24.64	24.69	24.67	0.1393	0.1409	0.1403
10	16QAM	1	0	23.37	23.49	23.69	0.1040	0.1069	0.1119
Channel				39675	40620	41565	EIRP(W)		
Frequency (MHz)				2498.5	2593	2687.5	L	M	H
5	QPSK	1	0	24.48	24.69	24.66	0.1343	0.1409	0.1400
5	16QAM	1	0	23.37	23.59	23.57	0.1040	0.1094	0.1089



LTE Band 2

Peak-to-Average Ratio

Mode	LTE Band 2 / 20MHz			
Mod.	QPSK	16QAM	64QAM	Limit: 13dB
RB Size	Full RB	Full RB	Full RB	Result
Middle CH	5.33	6.29	6.78	PASS



LTE Band 2 / 20MHz

Middle Channel / Full RB/ QPSK

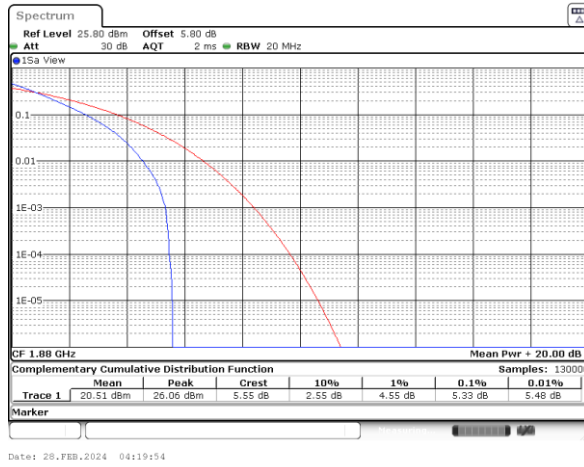

Middle Channel / Full RB/ 16QAM

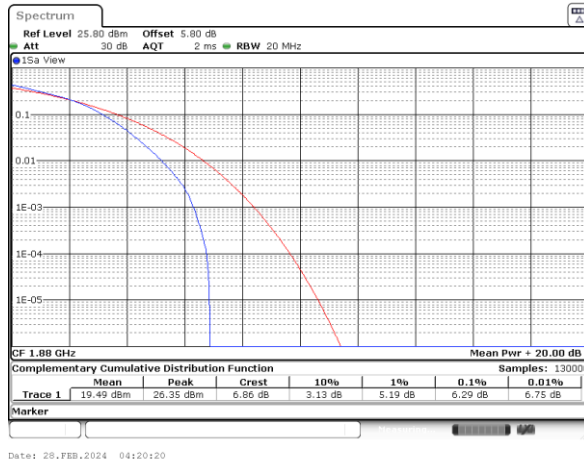

Middle Channel / Full RB/ 64QAM

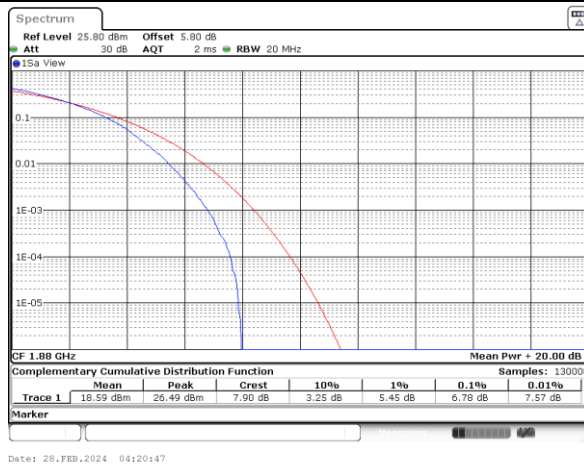



26dB Bandwidth

Mode	LTE Band 2 : 26dB BW(MHz)	
BW	1.4MHz	
Mod.	QPSK	16QAM
Middle CH	1.34	1.32
Mode	LTE Band 2 : 26dB BW(MHz)	
BW	3MHz	
Mod.	QPSK	16QAM
Middle CH	3.01	3.12
Mode	LTE Band 2 : 26dB BW(MHz)	
BW	5MHz	
Mod.	QPSK	16QAM
Middle CH	4.90	5.16
Mode	LTE Band 2 : 26dB BW(MHz)	
BW	10MHz	
Mod.	QPSK	16QAM
Middle CH	9.83	9.99
Mode	LTE Band 2 : 26dB BW(MHz)	
BW	15MHz	
Mod.	QPSK	16QAM
Middle CH	14.45	14.42
Mode	LTE Band 2 : 26dB BW(MHz)	
BW	20MHz	
Mod.	QPSK	16QAM
Middle CH	19.06	19.02



LTE Band 2

Middle Channel / 1.4MHz / QPSK

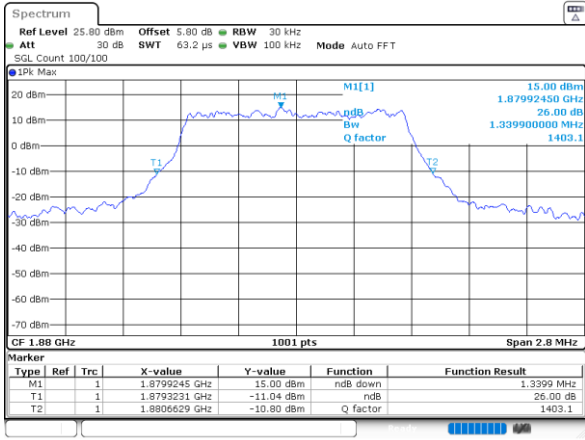

Date: 28.FEB.2024 02:56:05

Middle Channel / 1.4MHz / 16QAM

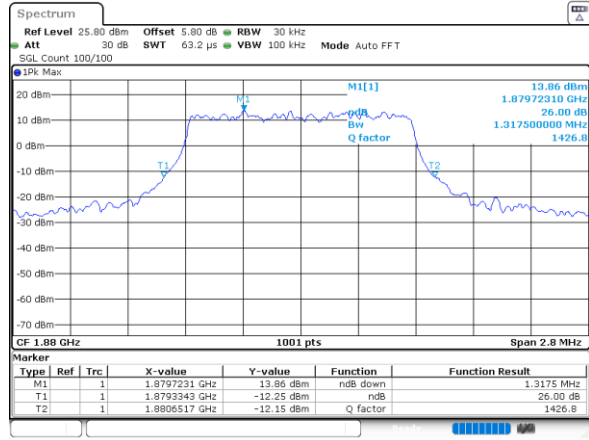

Date: 28.FEB.2024 02:56:130

LTE Band 2

Middle Channel / 3MHz / QPSK

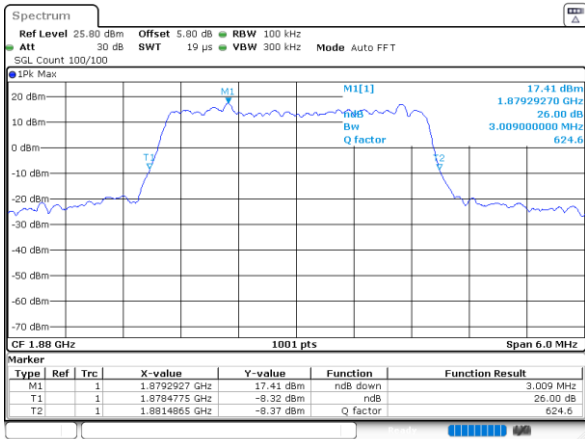

Date: 28.FEB.2024 03:45:46

Middle Channel / 3MHz / 16QAM

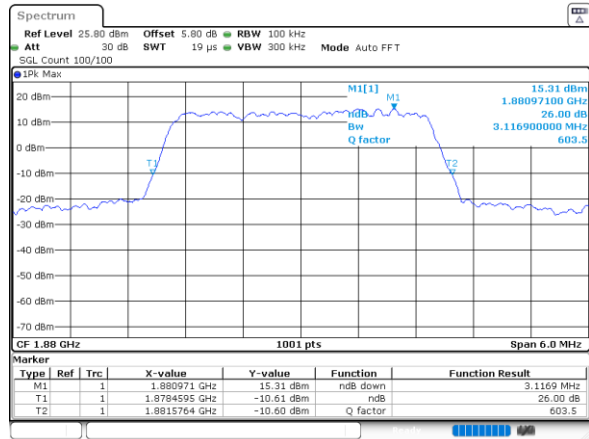

Date: 28.FEB.2024 03:46:11

LTE Band 2

Middle Channel / 5MHz / QPSK

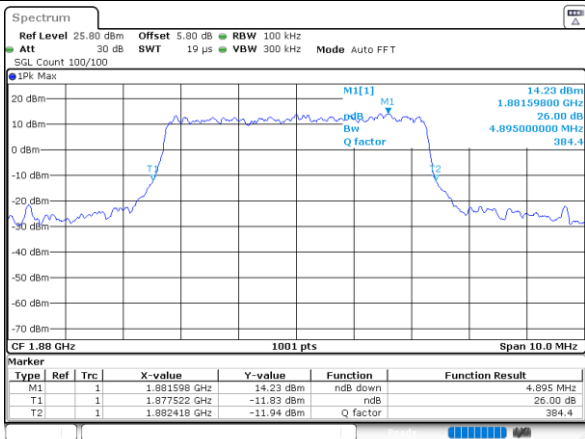

Date: 28.FEB.2024 04:02:24

Middle Channel / 5MHz / 16QAM

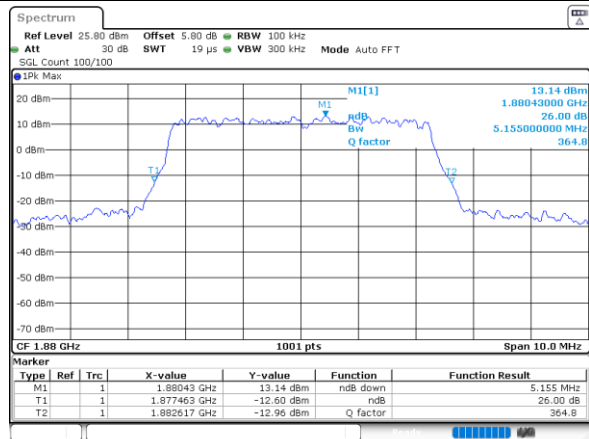

Date: 28.FEB.2024 04:02:150



LTE Band 2

Middle Channel / 10MHz / QPSK

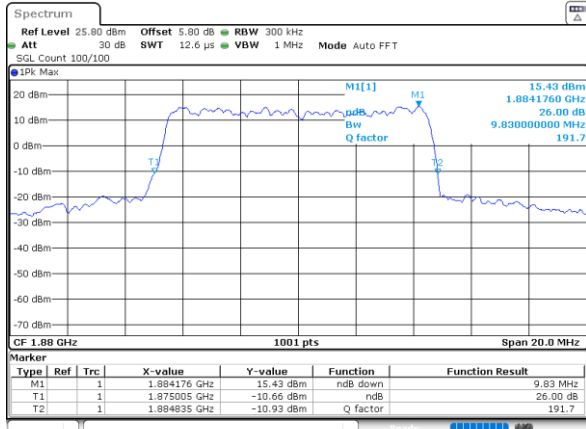

Date: 28.FEB.2024 03:15:02

Middle Channel / 10MHz / 16QAM

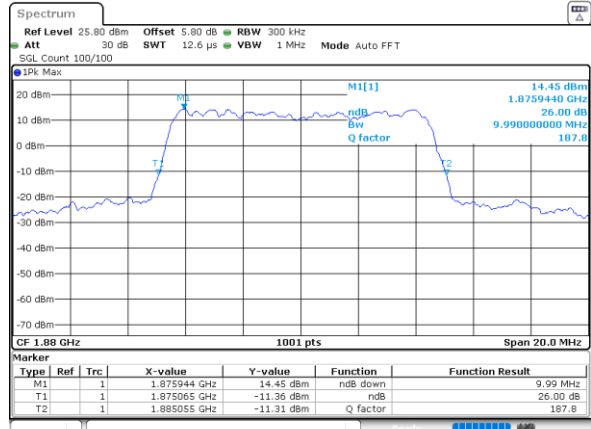

Date: 28.FEB.2024 03:15:27

LTE Band 2

Middle Channel / 15MHz / QPSK

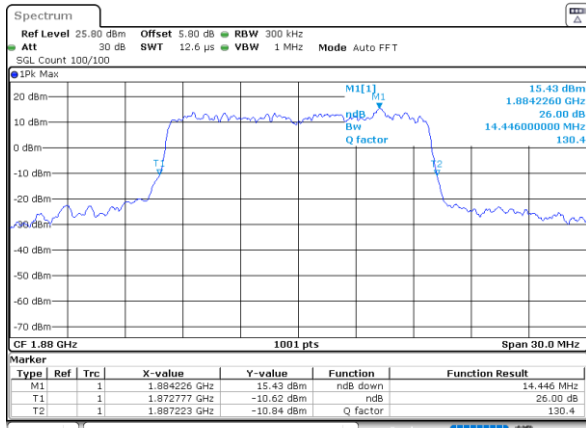

Date: 28.FEB.2024 04:07:41

Middle Channel / 15MHz / 16QAM

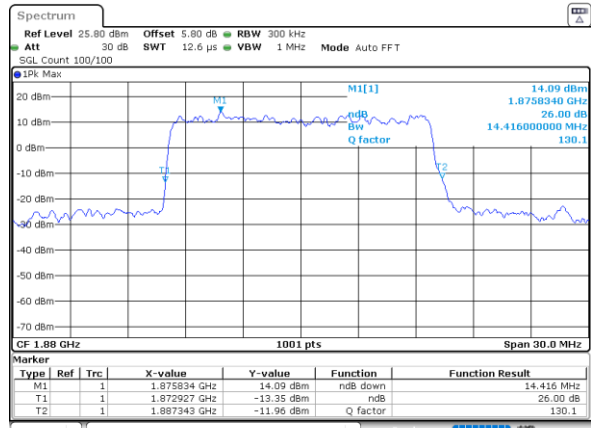

Date: 28.FEB.2024 04:08:07

LTE Band 2

Middle Channel / 20MHz / QPSK

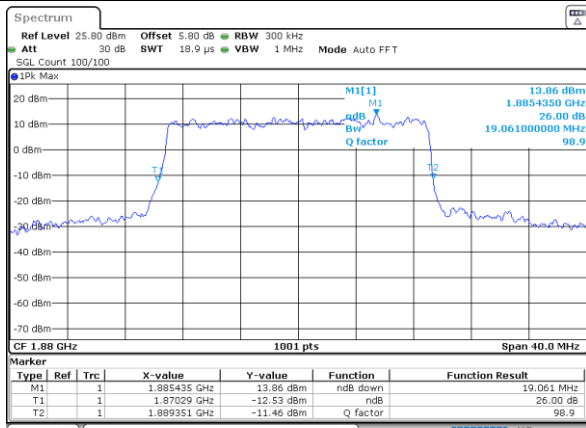

Date: 28.FEB.2024 04:18:47

Middle Channel / 20MHz / 16QAM

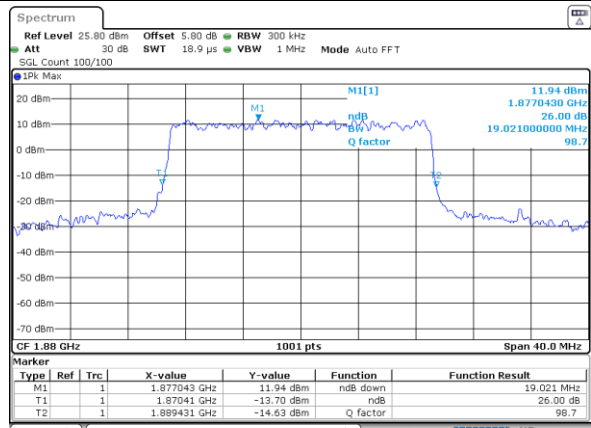

Date: 28.FEB.2024 04:19:13



Occupied Bandwidth

Mode	LTE Band 2 : 99%OBW(MHz)	
BW	1.4MHz	
Mod.	QPSK	16QAM
Middle CH	1.09	1.11
Mode	LTE Band 2 : 99%OBW(MHz)	
BW	3MHz	
Mod.	QPSK	16QAM
Middle CH	2.75	2.73
Mode	LTE Band 2 : 99%OBW(MHz)	
BW	5MHz	
Mod.	QPSK	16QAM
Middle CH	4.51	4.50
Mode	LTE Band 2 : 99%OBW(MHz)	
BW	10MHz	
Mod.	QPSK	16QAM
Middle CH	9.09	9.05
Mode	LTE Band 2 : 99%OBW(MHz)	
BW	15MHz	
Mod.	QPSK	16QAM
Middle CH	13.49	13.49
Mode	LTE Band 2 : 99%OBW(MHz)	
BW	20MHz	
Mod.	QPSK	16QAM
Middle CH	17.90	17.90



LTE Band 2

Middle Channel / 1.4MHz / QPSK

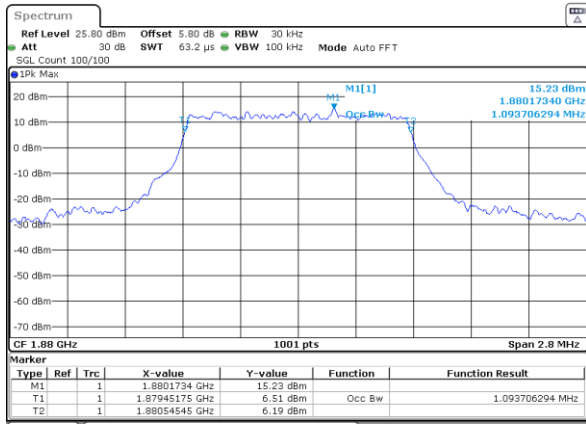

Date: 28.FEB.2024 02:55:51

Middle Channel / 1.4MHz / 16QAM

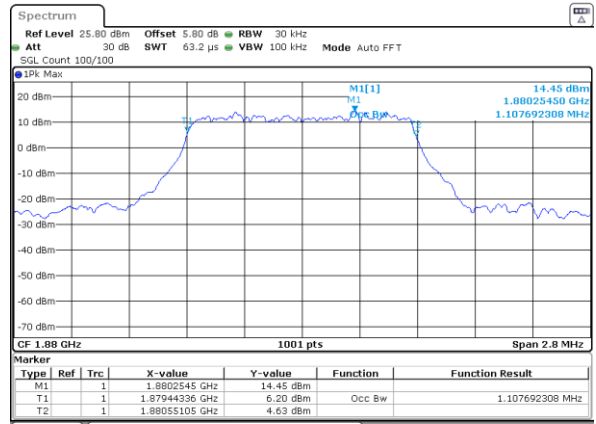

Date: 28.FEB.2024 02:56:14

LTE Band 2

Middle Channel / 3MHz / QPSK

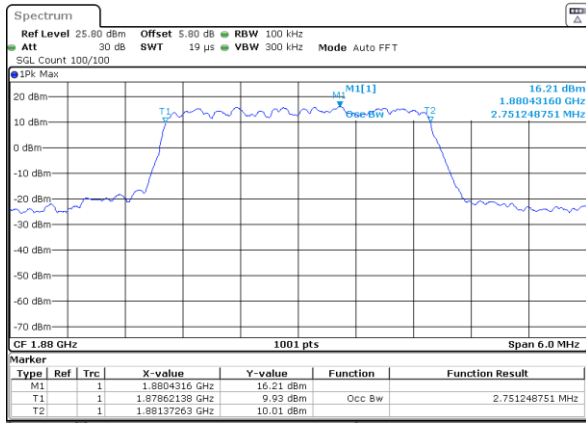

Date: 28.FEB.2024 03:45:32

Middle Channel / 3MHz / 16QAM

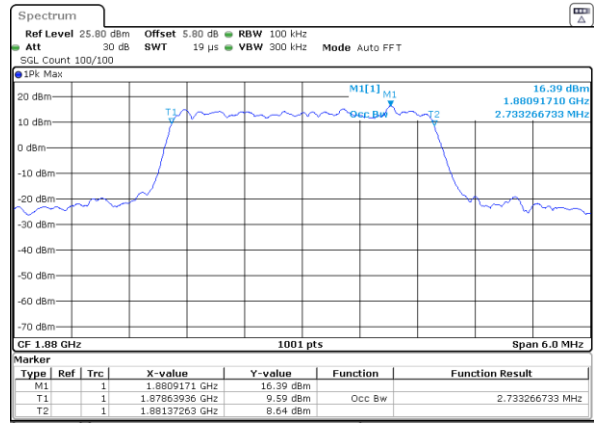

Date: 28.FEB.2024 03:46:25

LTE Band 2

Middle Channel / 5MHz / QPSK

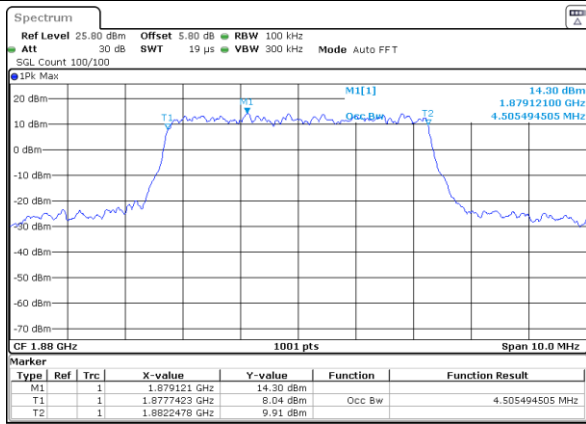

Date: 28.FEB.2024 04:02:10

Middle Channel / 5MHz / 16QAM

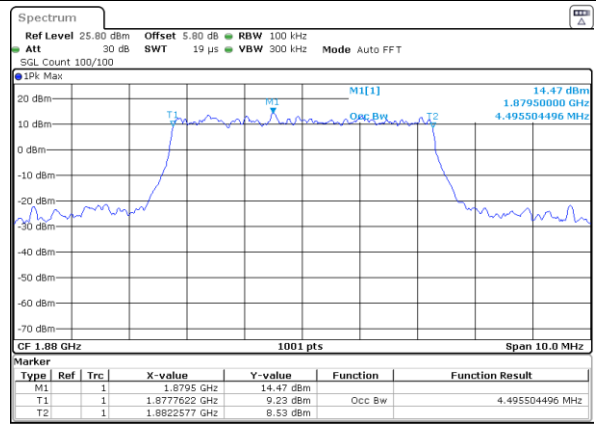

Date: 28.FEB.2024 04:03:04



LTE Band 2

Middle Channel / 10MHz / QPSK

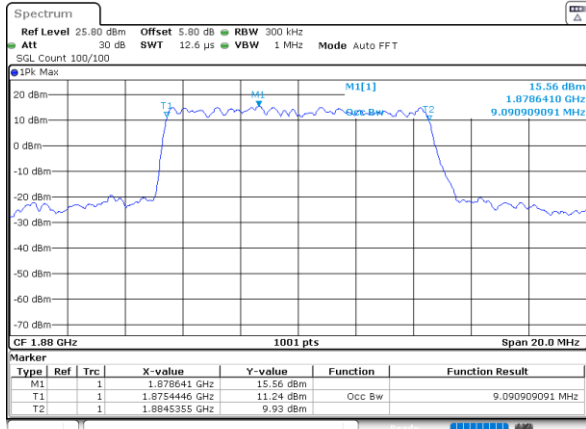

Date: 28.FEB.2024 03:14:48

Middle Channel / 10MHz / 16QAM

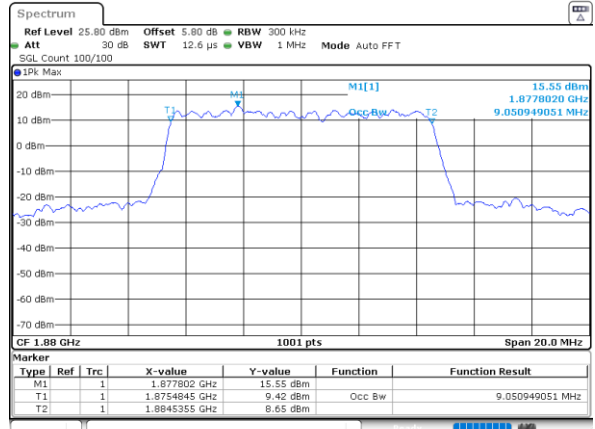

Date: 28.FEB.2024 03:15:41

LTE Band 2

Middle Channel / 15MHz / QPSK

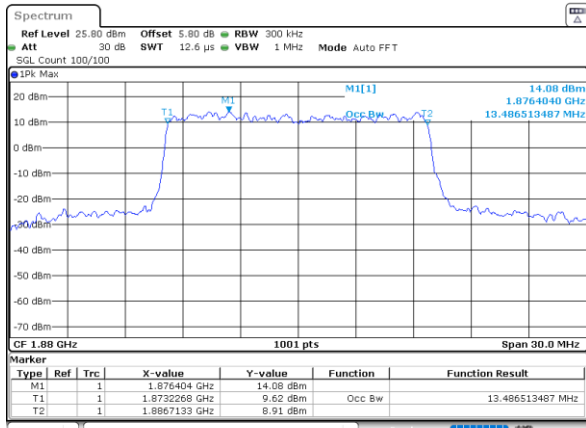

Date: 28.FEB.2024 04:07:27

Middle Channel / 15MHz / 16QAM

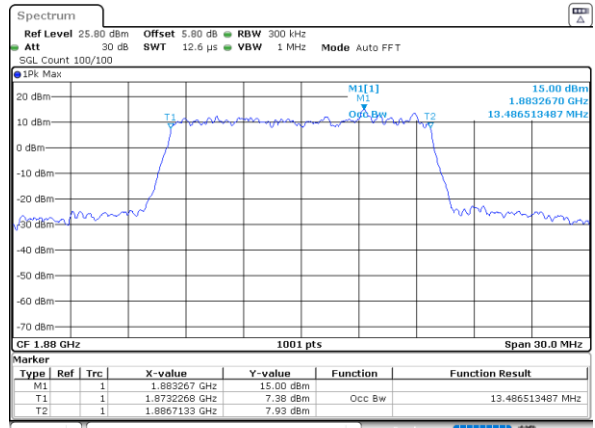

Date: 28.FEB.2024 04:08:21

LTE Band 2

Middle Channel / 20MHz / QPSK

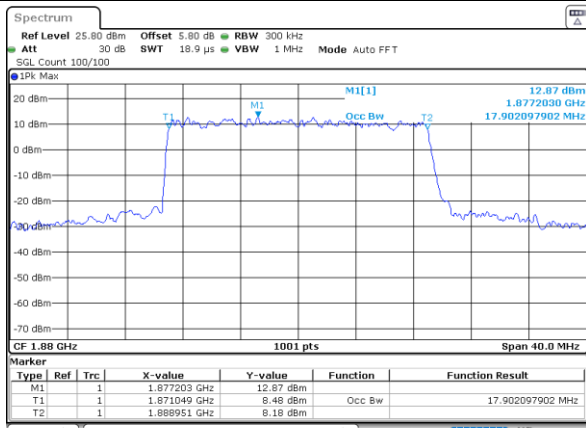

Date: 28.FEB.2024 04:18:33

Middle Channel / 20MHz / 16QAM

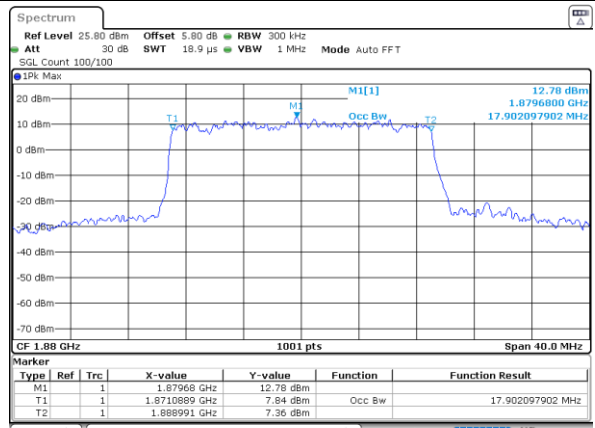

Date: 28.FEB.2024 04:19:27



Conducted Band Edge

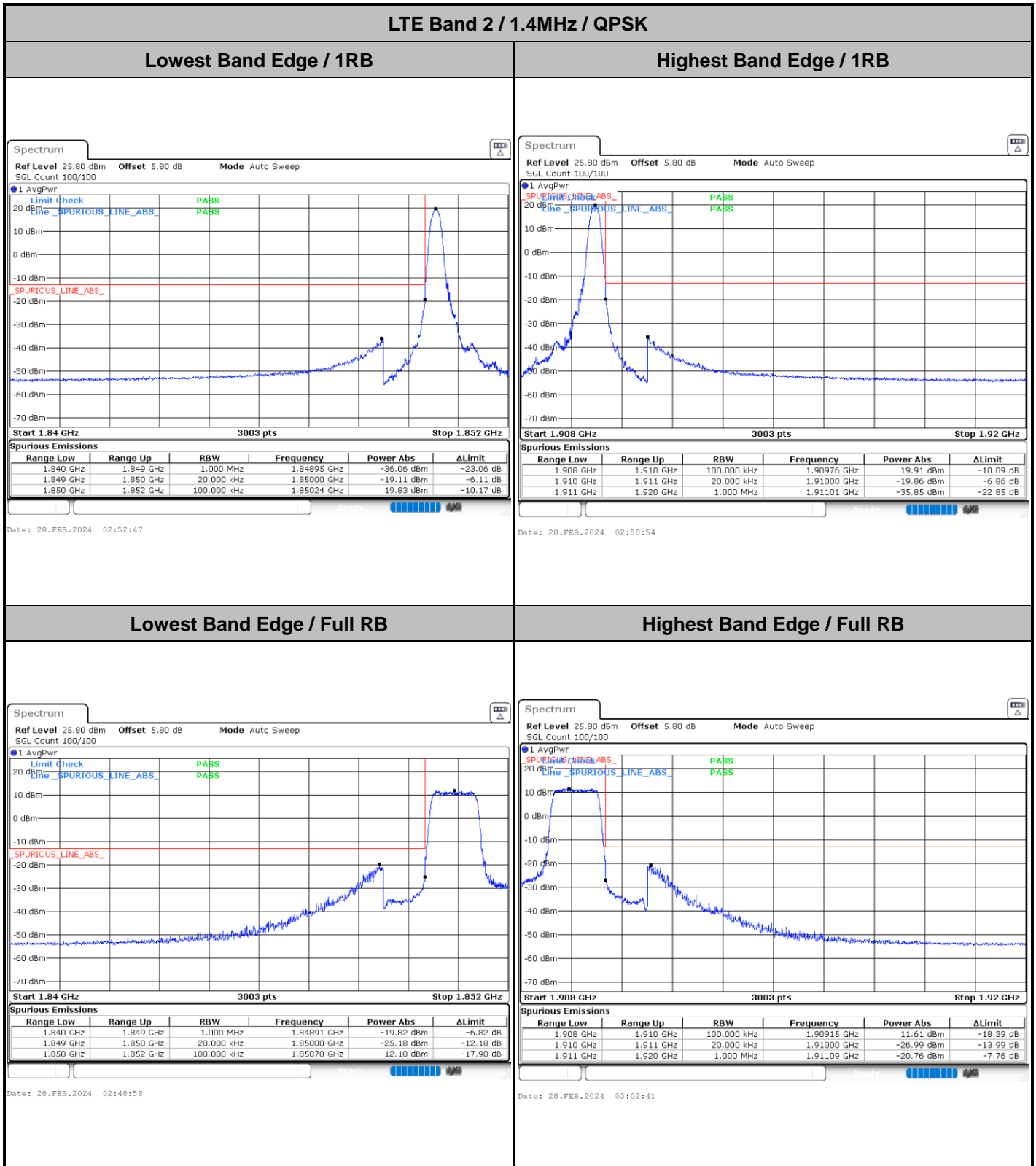



LTE Band 2 / 1.4MHz / 16QAM

Lowest Band Edge / 1 RB

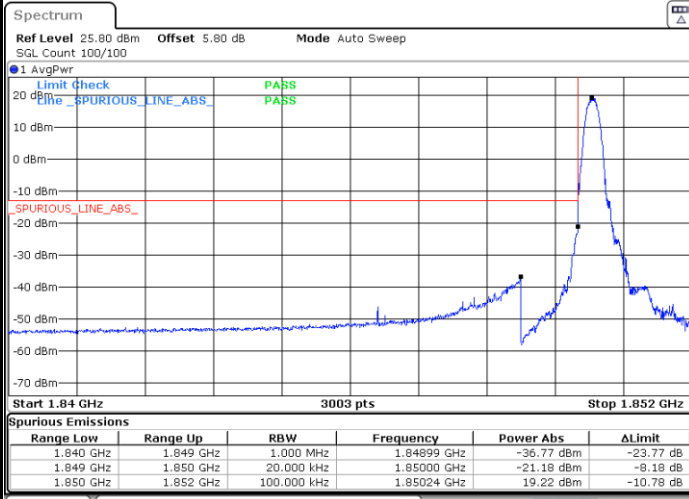

Date: 28.FEB.2024 02:52:01

Highest Band Edge / 1 RB

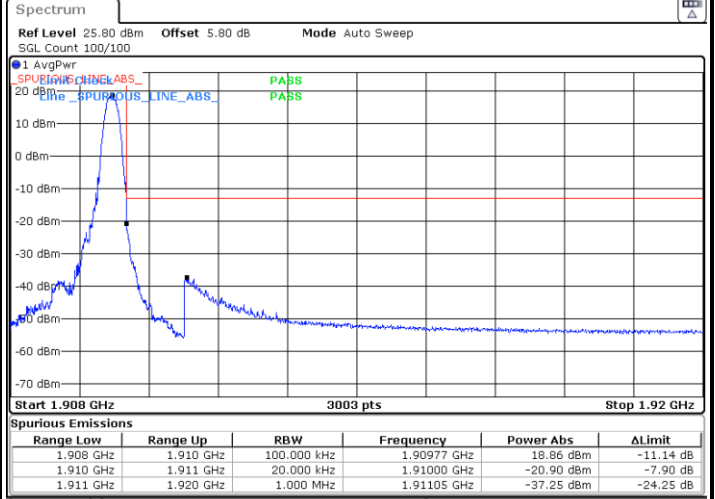

Date: 28.FEB.2024 02:59:39

Lowest Band Edge / Full RB

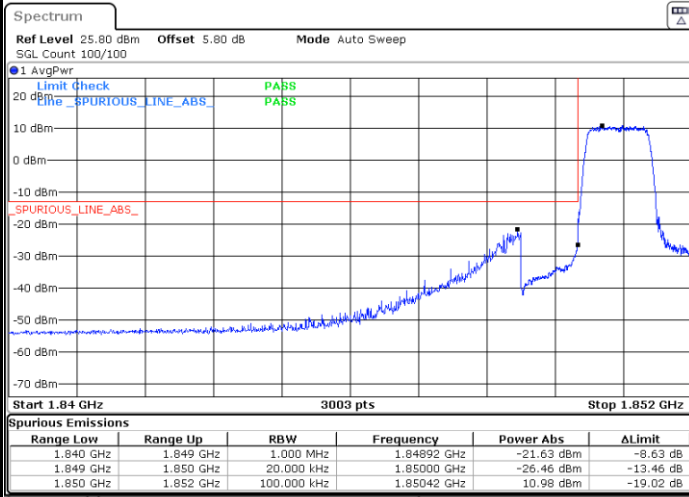

Date: 28.FEB.2024 02:49:44

Highest Band Edge / Full RB

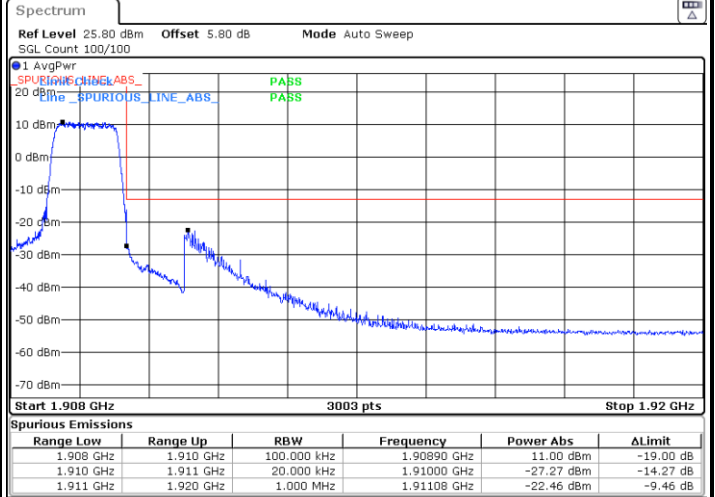

Date: 28.FEB.2024 03:01:56



LTE Band 2 / 1.4MHz / 64QAM

Lowest Band Edge / 1 RB

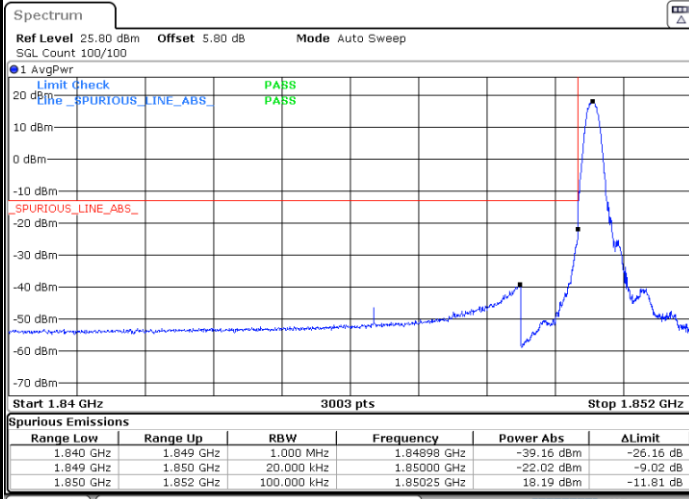

Date: 28.FEB.2024 02:51:16

Highest Band Edge / 1 RB

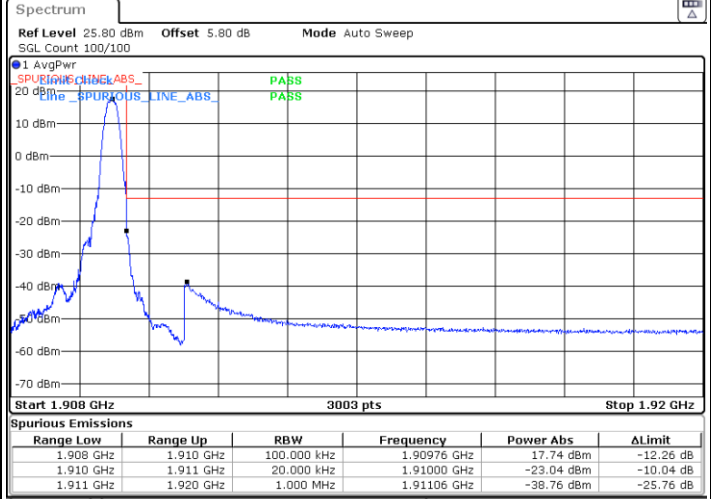

Date: 28.FEB.2024 03:00:25

Lowest Band Edge / Full RB

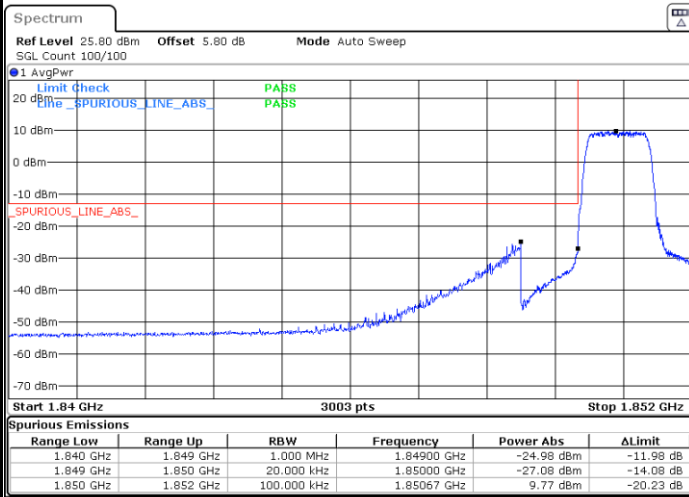

Date: 28.FEB.2024 02:50:30

Highest Band Edge / Full RB

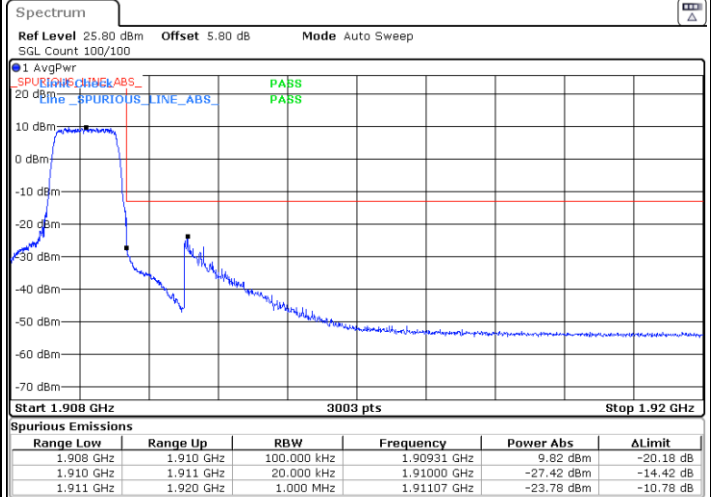

Date: 28.FEB.2024 03:01:10



LTE Band 2 / 10MHz / QPSK

Lowest Band Edge / 1 RB

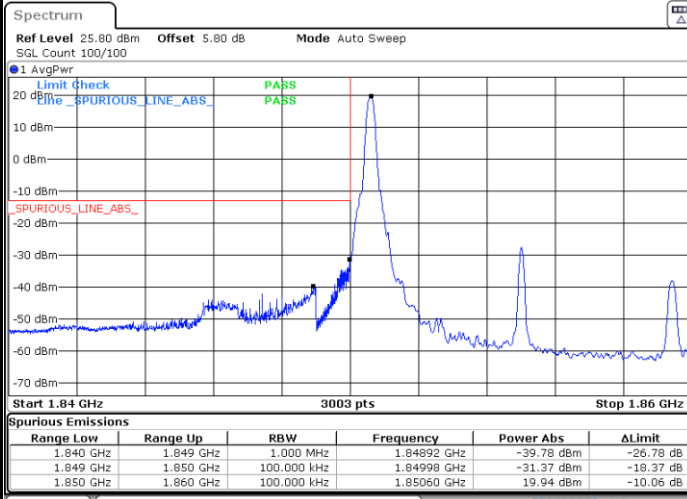

Date: 28.FEB.2024 03:11:44

Highest Band Edge / 1 RB

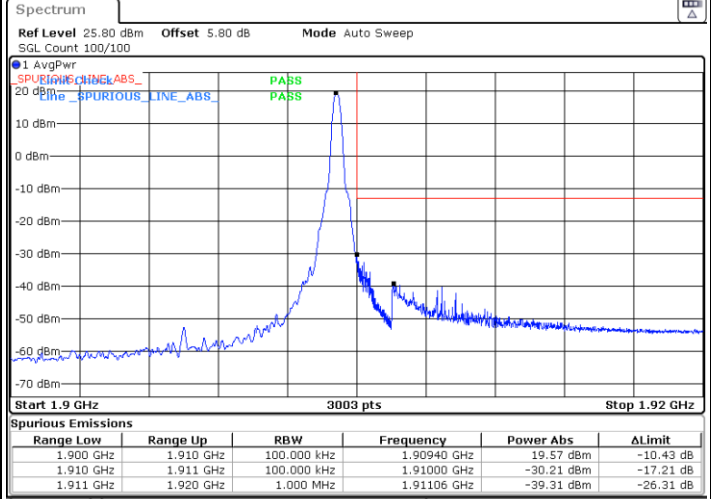

Date: 28.FEB.2024 03:17:51

Lowest Band Edge / Full RB

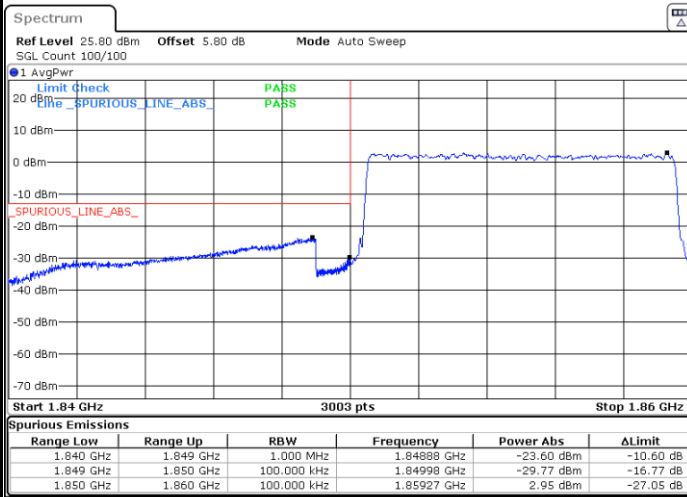

Date: 28.FEB.2024 03:07:56

Highest Band Edge / Full RB

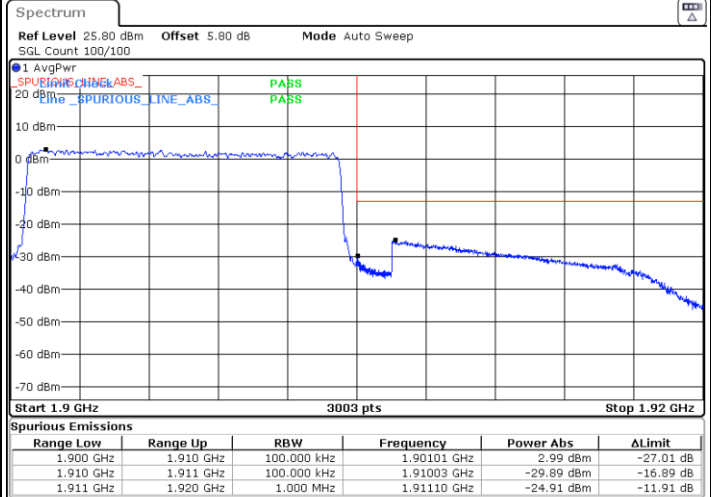

Date: 28.FEB.2024 03:21:39



LTE Band 2 / 10MHz / 16QAM

Lowest Band Edge / 1 RB

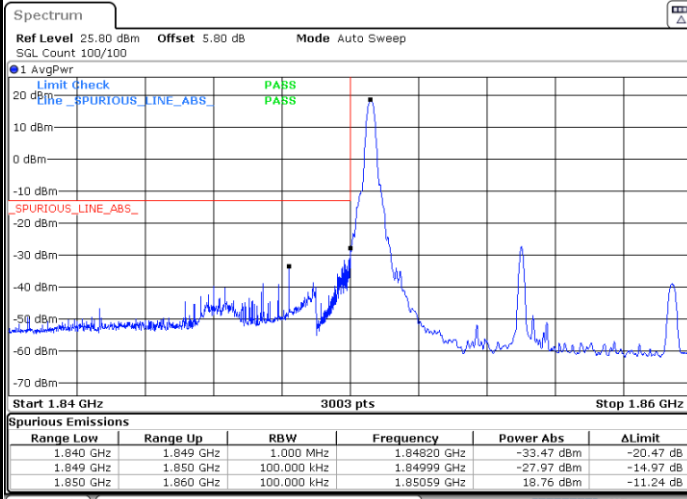

Date: 28.FEB.2024 03:10:58

Highest Band Edge / 1 RB

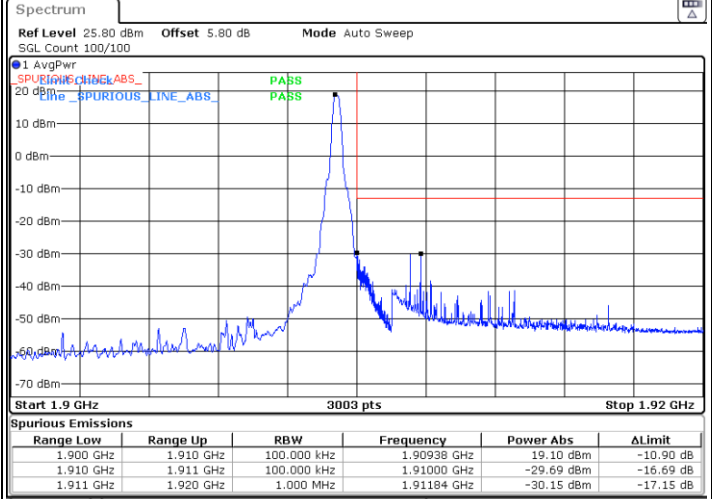

Date: 28.FEB.2024 03:18:36

Lowest Band Edge / Full RB

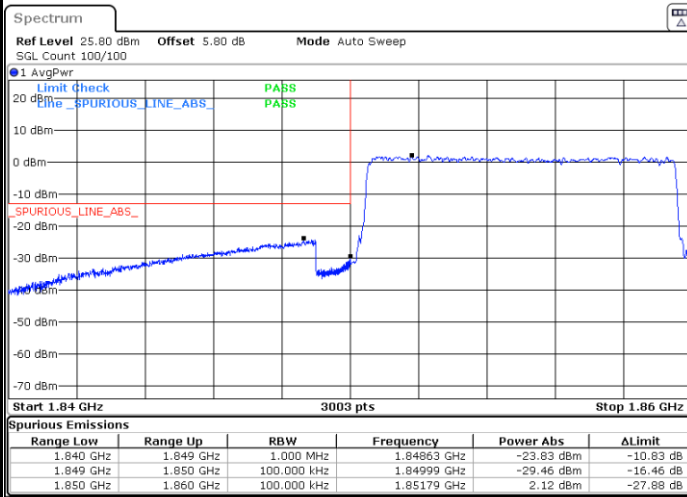

Date: 28.FEB.2024 03:08:42

Highest Band Edge / Full RB

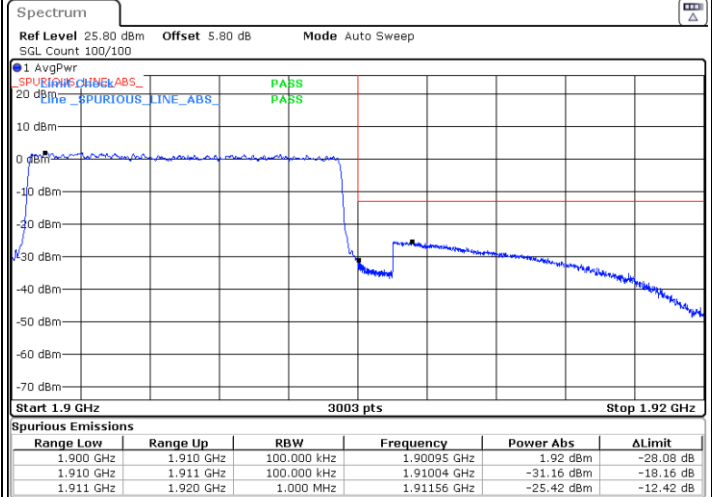

Date: 28.FEB.2024 03:20:53



LTE Band 2 / 10MHz / 64QAM

Lowest Band Edge / 1 RB

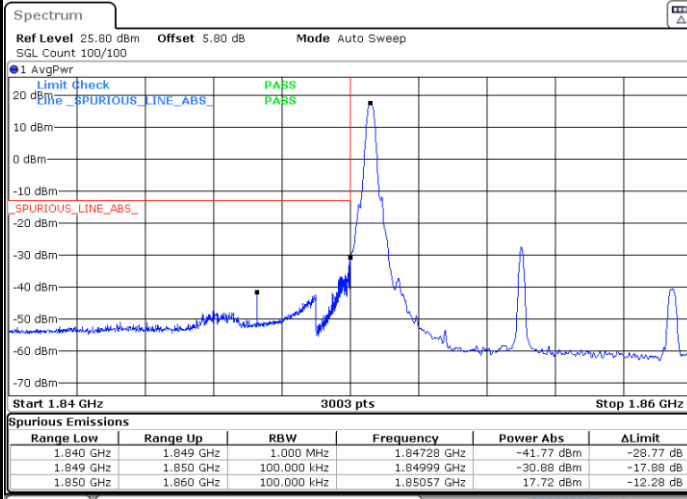

Date: 28.FEB.2024 03:10:13

Highest Band Edge / 1 RB

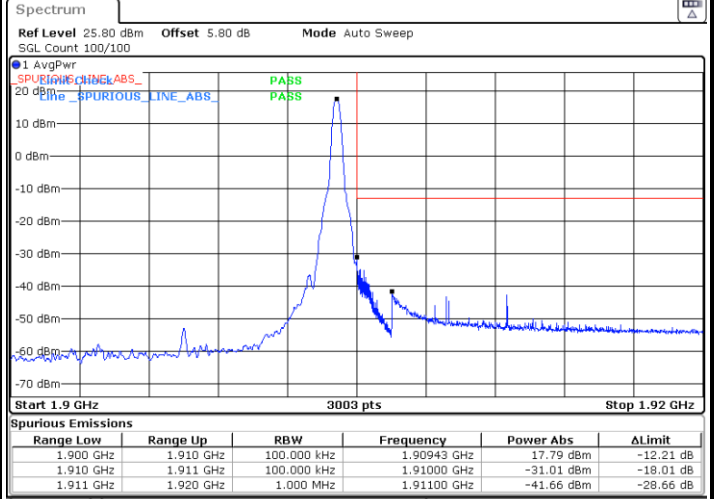

Date: 28.FEB.2024 03:19:22

Lowest Band Edge / Full RB

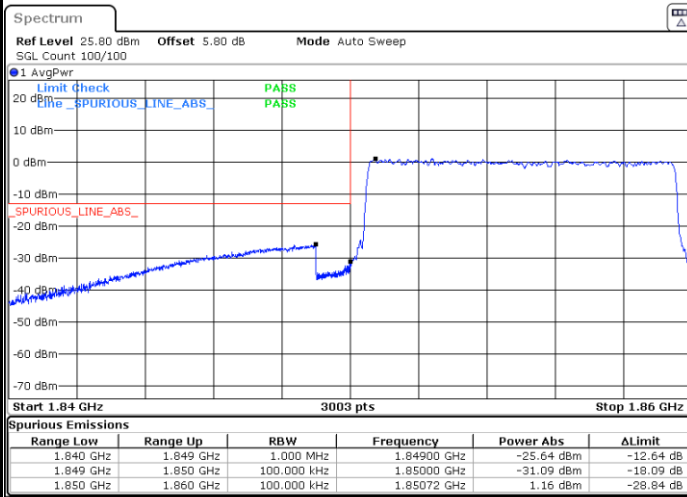

Date: 28.FEB.2024 03:09:27

Highest Band Edge / Full RB

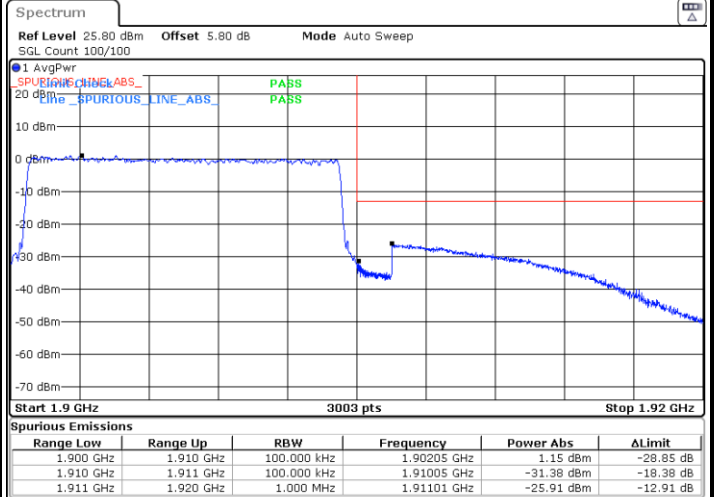

Date: 28.FEB.2024 03:20:08



LTE Band 2 / 20MHz / QPSK

Lowest Band Edge / 1 RB

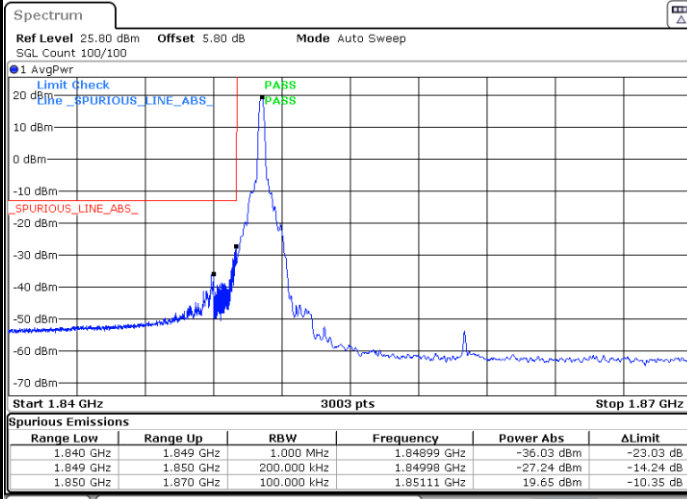

Date: 28.FEB.2024 03:36:04

Highest Band Edge / 1 RB

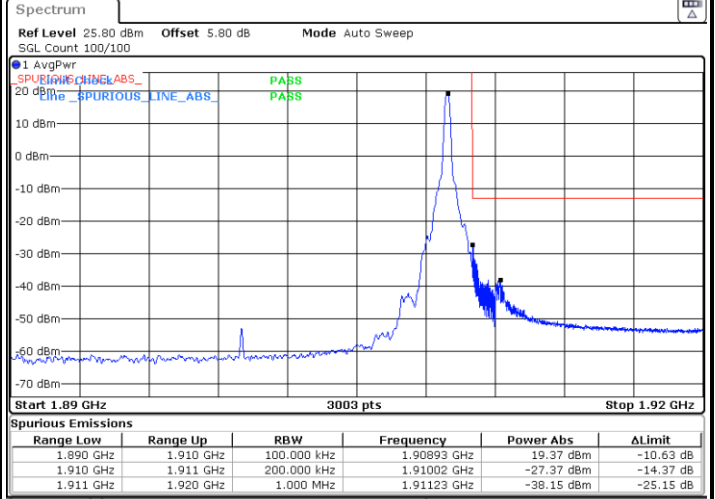

Date: 28.FEB.2024 04:14:20

Lowest Band Edge / Full RB

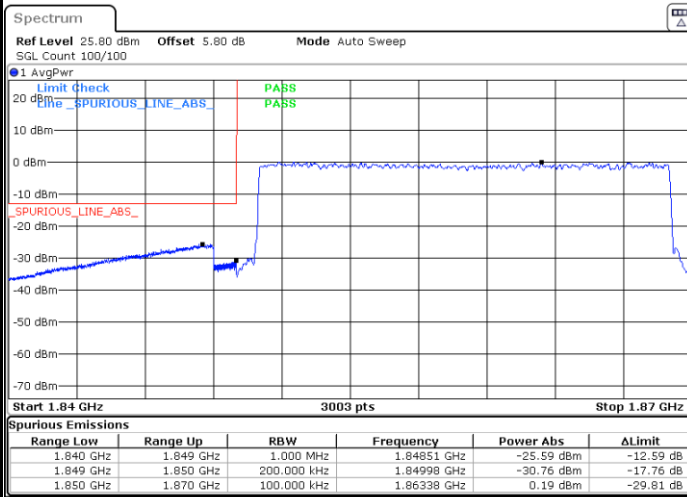

Date: 28.FEB.2024 03:32:17

Highest Band Edge / Full RB

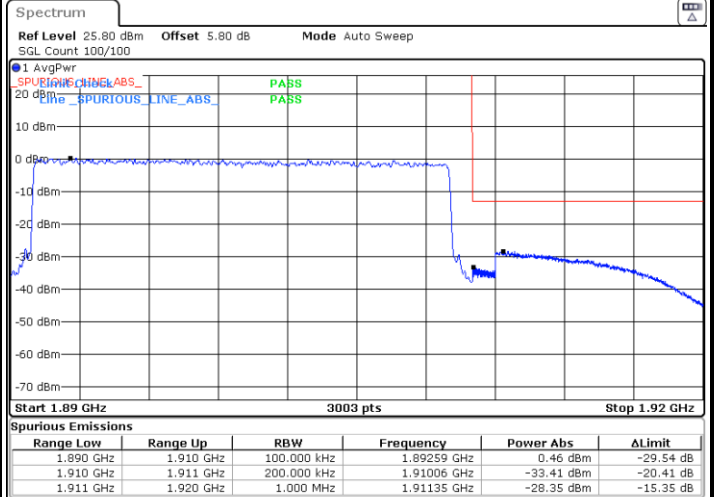

Date: 28.FEB.2024 04:18:07



LTE Band 2 / 20MHz / 16QAM

Lowest Band Edge / 1 RB

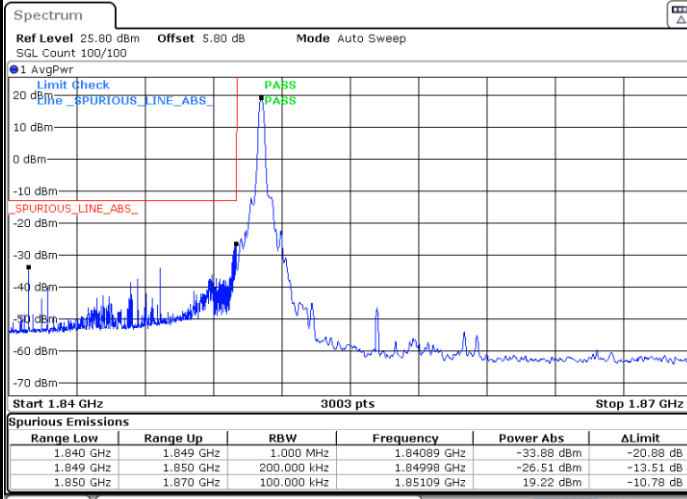

Date: 28.FEB.2024 03:35:19

Highest Band Edge / 1 RB

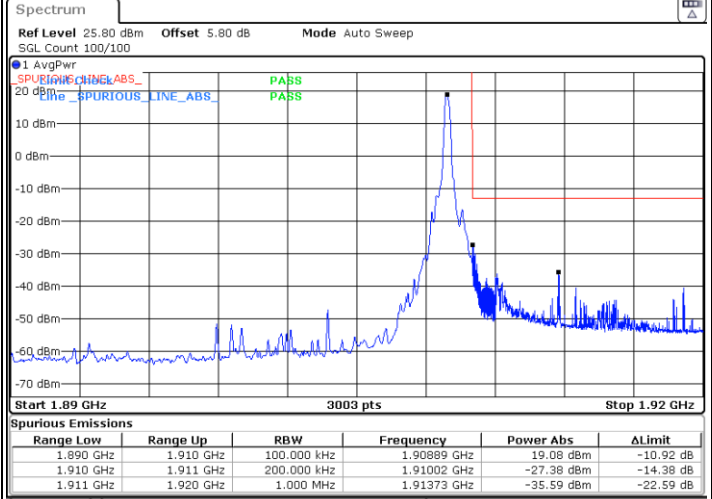

Date: 28.FEB.2024 04:15:05

Lowest Band Edge / Full RB

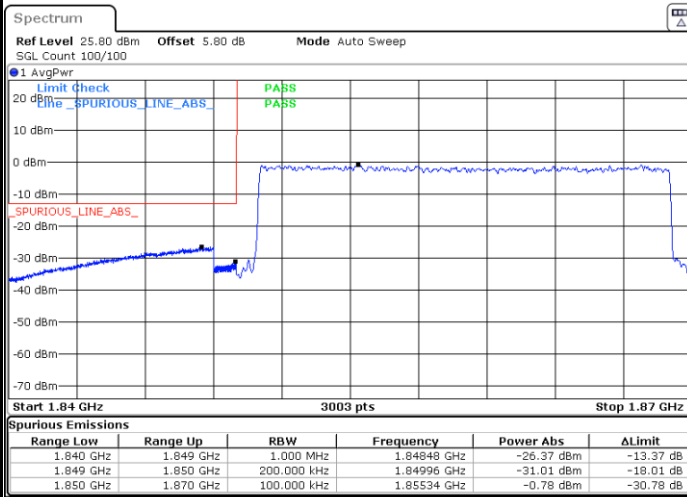

Date: 28.FEB.2024 03:33:02

Highest Band Edge / Full RB

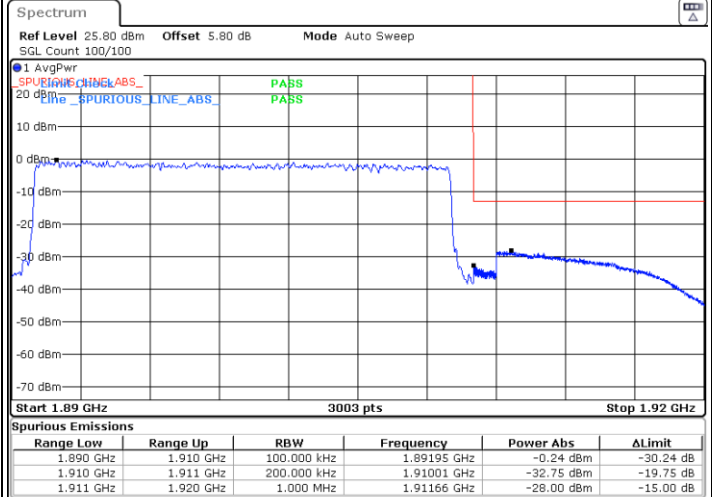

Date: 28.FEB.2024 04:17:21



LTE Band 2 / 20MHz / 64QAM

Lowest Band Edge / 1 RB

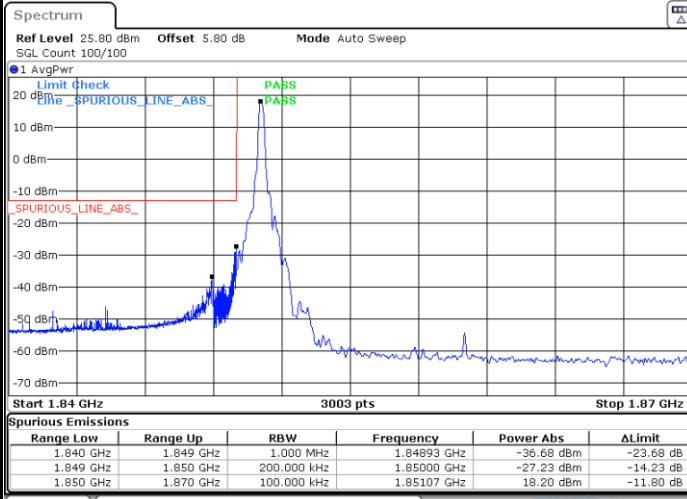

Date: 28.FEB.2024 03:34:33

Highest Band Edge / 1 RB

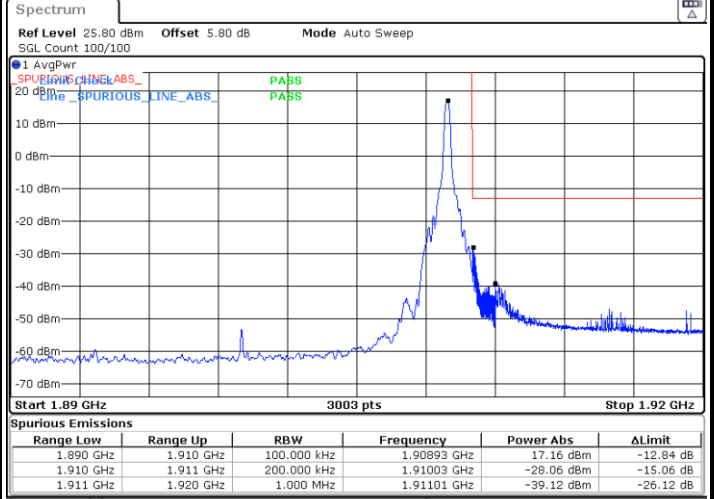

Date: 28.FEB.2024 04:15:51

Lowest Band Edge / Full RB

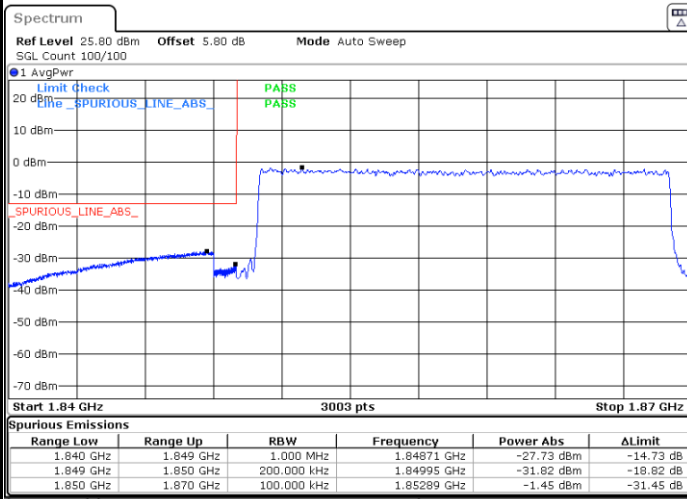

Date: 28.FEB.2024 03:33:48

Highest Band Edge / Full RB

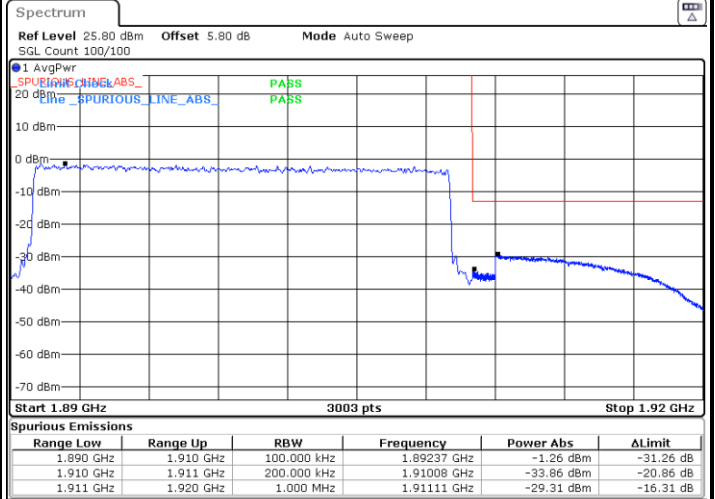

Date: 28.FEB.2024 04:16:36



Conducted Spurious Emission

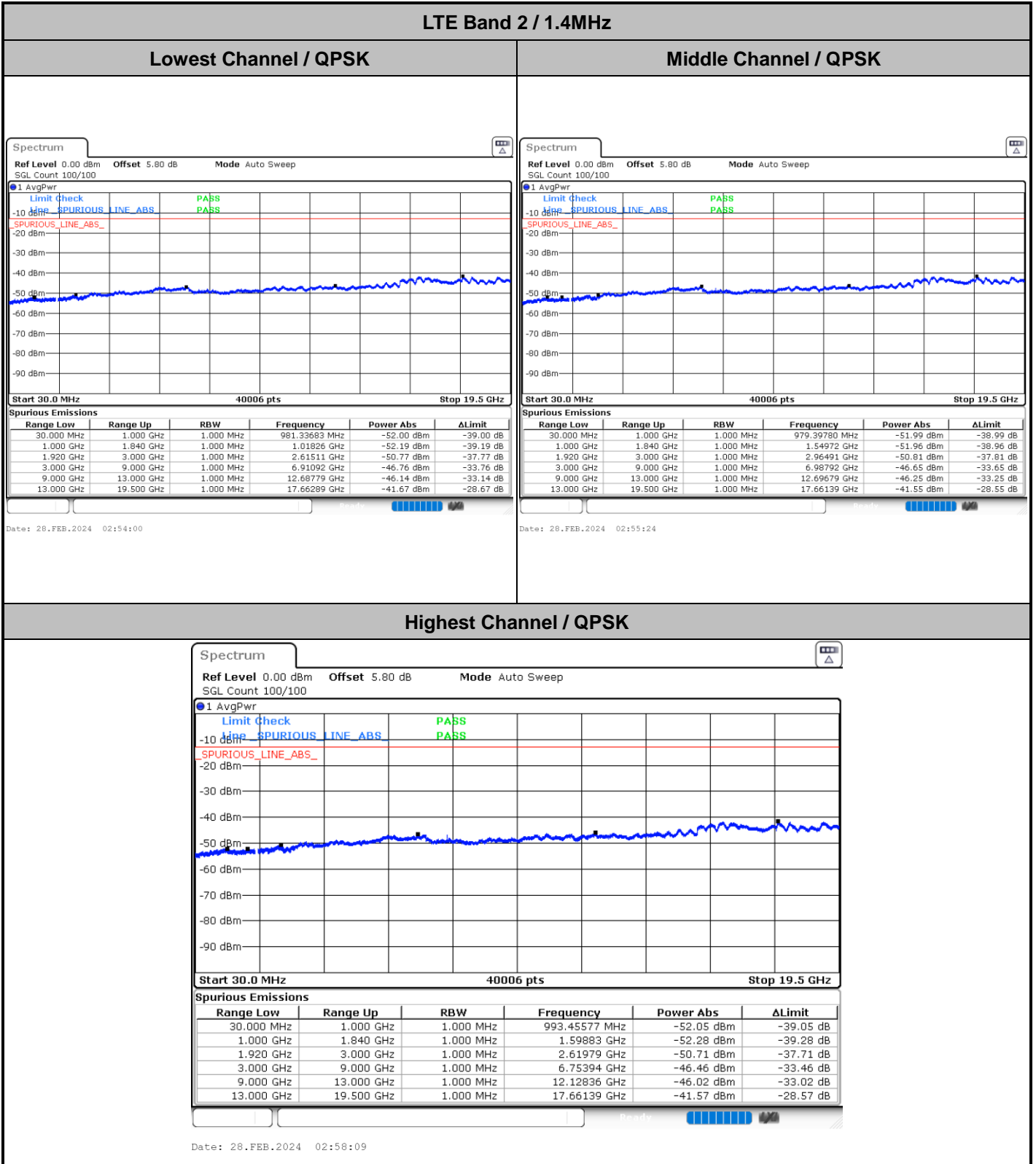



LTE Band 2 / 10MHz

Lowest Channel / QPSK

Middle Channel / QPSK

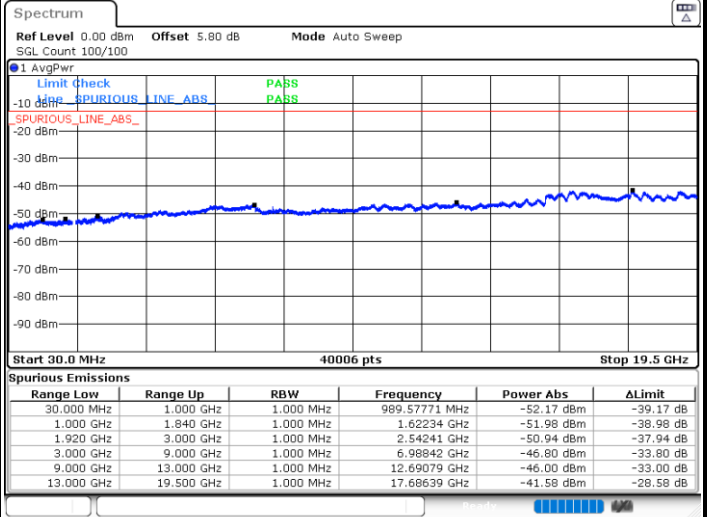
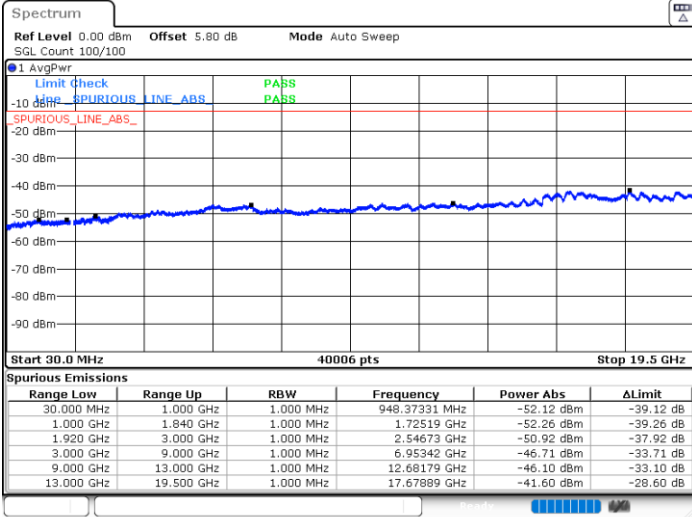

Date: 28.FEB.2024 03:12:57

Date: 28.FEB.2024 03:14:21

Highest Channel / QPSK

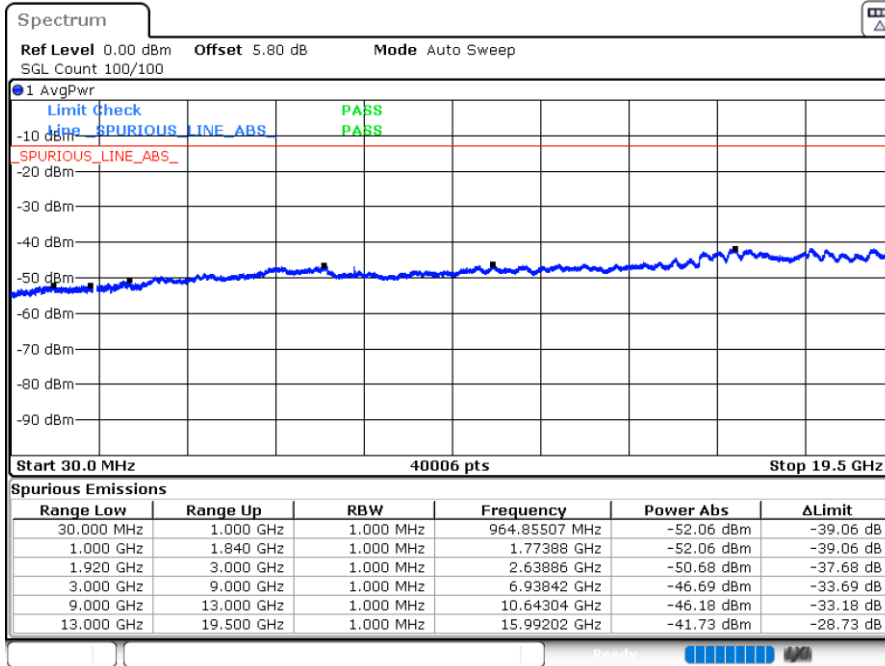

Date: 28.FEB.2024 03:17:06



LTE Band 2 / 20MHz

Lowest Channel / QPSK

Middle Channel / QPSK

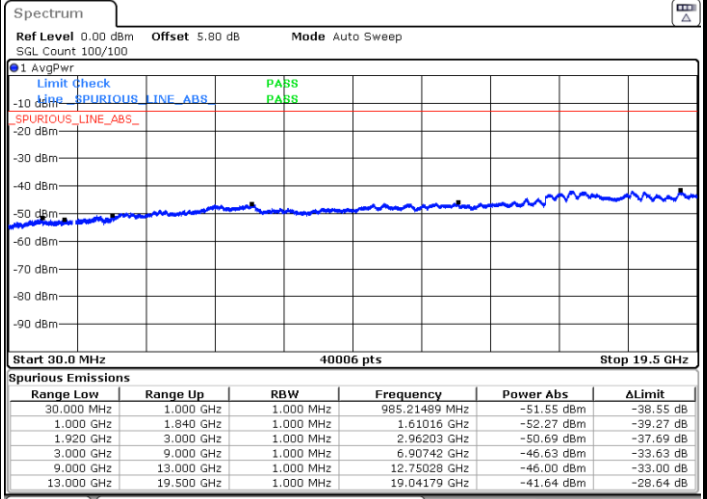
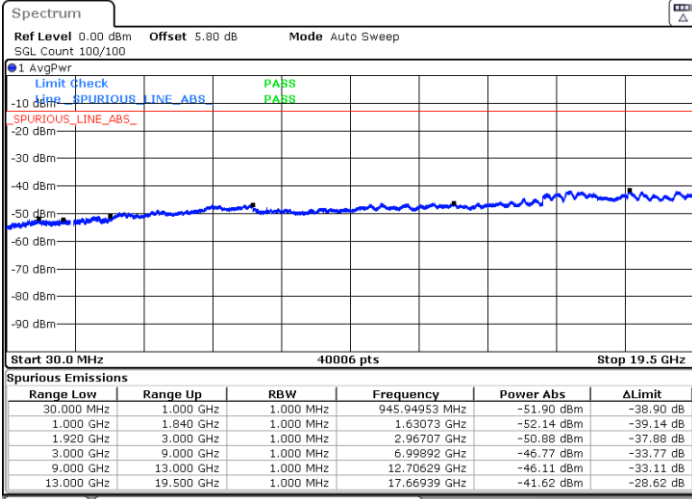

Date: 28.FEB.2024 03:37:17

Date: 28.FEB.2024 04:12:10

Highest Channel / QPSK

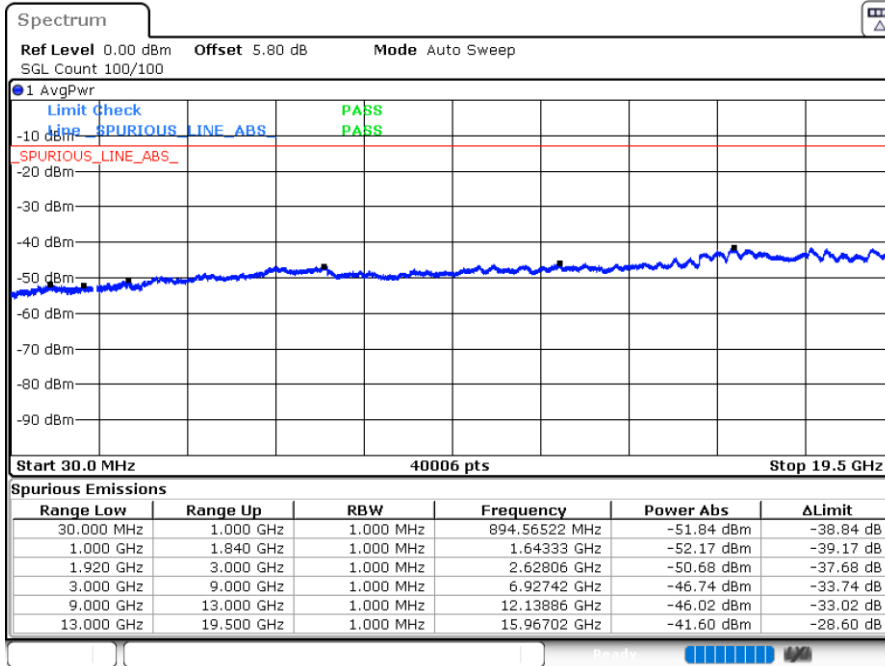

Date: 28.FEB.2024 04:13:34



Frequency Stability

Test Conditions		LTE Band 2 (QPSK) / Middle Channel	Limit
Temperature (°C)	Voltage (Volt)	BW 10MHz	Note 2.
		Deviation (ppm)	Result
50	Normal Voltage	0.0027	PASS
40	Normal Voltage	0.0013	
30	Normal Voltage	0.0009	
20(Ref.)	Normal Voltage	0.0000	
10	Normal Voltage	0.0015	
0	Normal Voltage	0.0037	
-10	Normal Voltage	0.0021	
-20	Normal Voltage	0.0034	
-30	Normal Voltage	0.0016	
20	Maximum Voltage	0.0022	
20	Normal Voltage	0.0004	
20	Battery End Point	0.0035	

Note:

1. Normal Voltage = 3.91 V. ; Battery End Point (BEP) =3.6 V. ; Maximum Voltage = 4.53 V.
2. Note: The frequency fundamental emissions stay within the authorized frequency block.



LTE Band 4

Peak-to-Average Ratio

Mode	LTE Band 4 / 20MHz			
Mod.	QPSK	16QAM	64QAM	Limit: 13dB
RB Size	Full RB	Full RB	Full RB	Result
Middle CH	5.36	6.41	6.72	PASS



LTE Band 4 / 20MHz

Middle Channel / Full RB/ QPSK

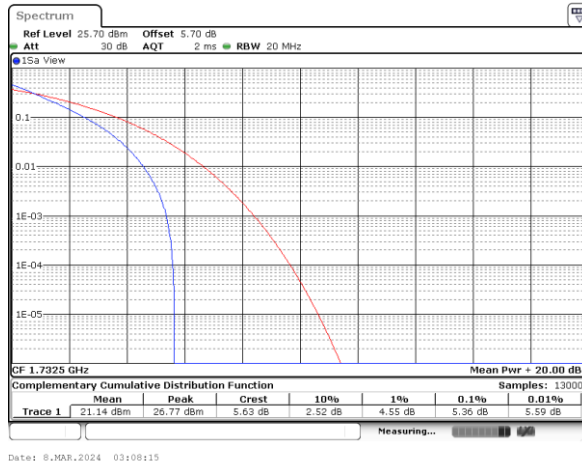

Middle Channel / Full RB/ 16QAM

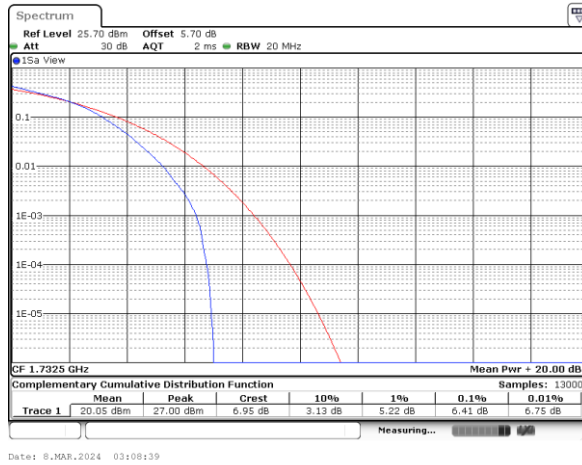

Middle Channel / Full RB/ 64QAM

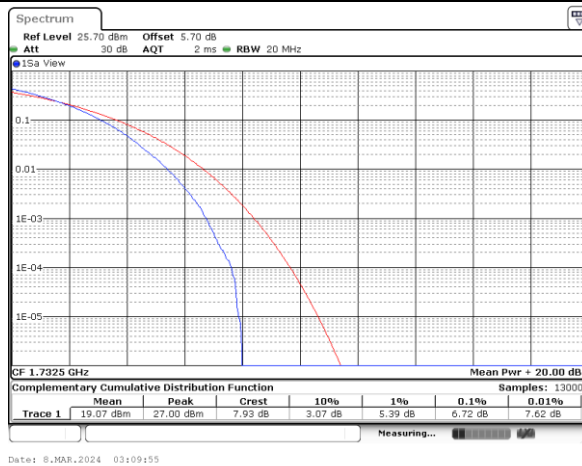



26dB Bandwidth

BW	1.4MHz	
Mod.	QPSK	16QAM
Middle CH	1.35	1.38
BW	3MHz	
Mod.	QPSK	16QAM
Middle CH	3.10	3.09
BW	5MHz	
Mod.	QPSK	16QAM
Middle CH	5.01	5.03
BW	10MHz	
Mod.	QPSK	16QAM
Middle CH	9.75	9.73
BW	15MHz	
Mod.	QPSK	16QAM
Middle CH	14.66	14.48
BW	20MHz	
Mod.	QPSK	16QAM
Middle CH	19.34	19.30



LTE Band 4

Middle Channel / 1.4MHz / QPSK

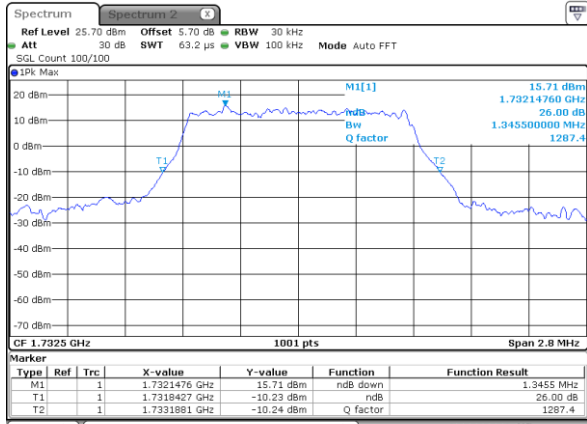

Date: 8.MAR.2024 22:29:43

Middle Channel / 1.4MHz / 16QAM

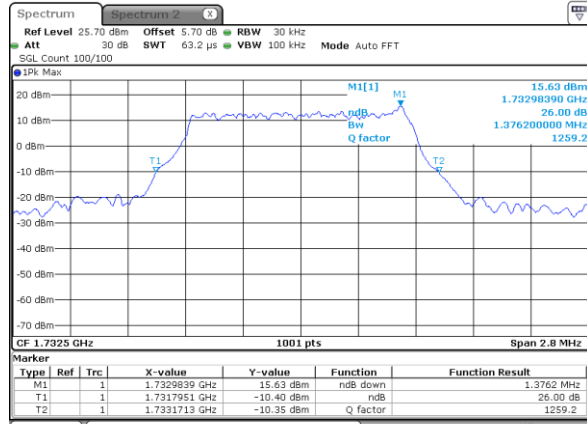

Date: 8.MAR.2024 22:30:09

LTE Band 4

Middle Channel / 3MHz / QPSK

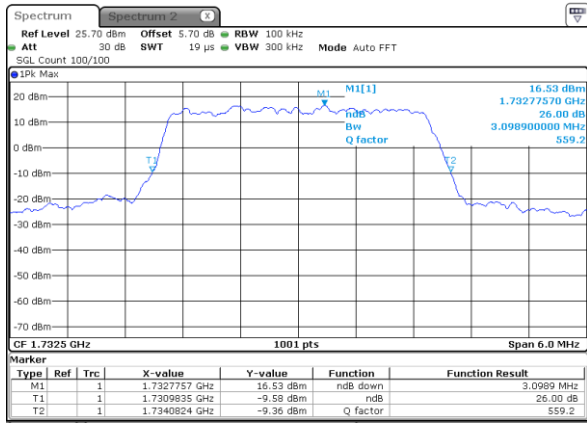

Date: 8.MAR.2024 22:36:30

Middle Channel / 3MHz / 16QAM

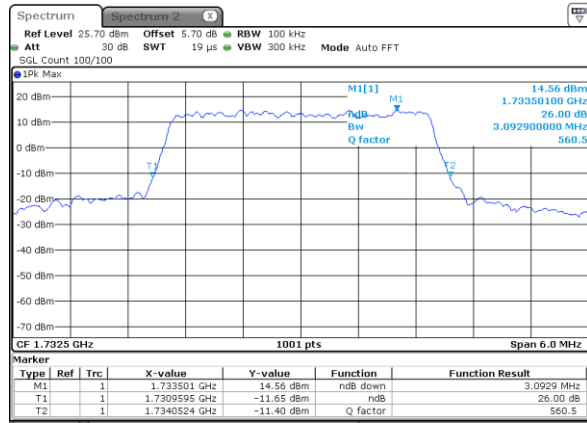

Date: 8.MAR.2024 22:36:56

LTE Band 4

Middle Channel / 5MHz / QPSK

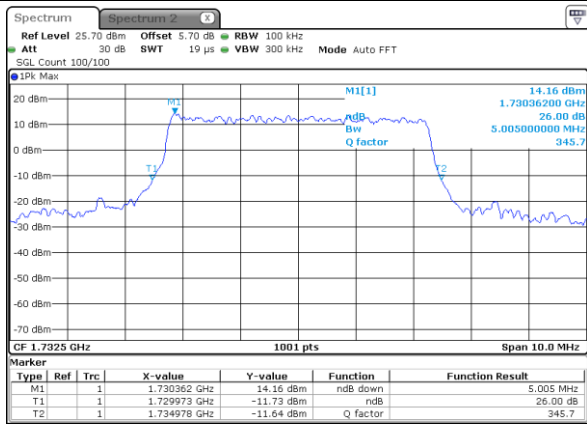

Date: 8.MAR.2024 22:56:59

Middle Channel / 5MHz / 16QAM

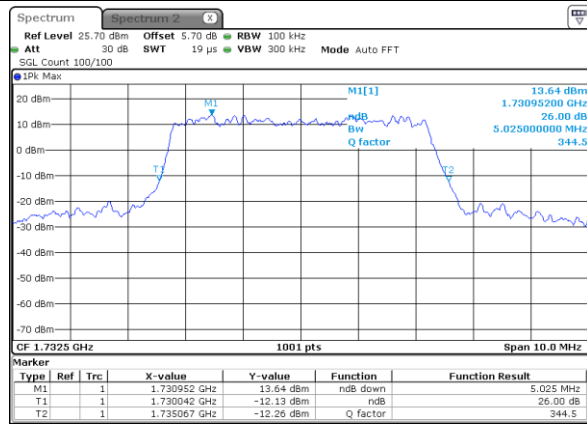

Date: 8.MAR.2024 22:57:24



LTE Band 4

Middle Channel / 10MHz / QPSK

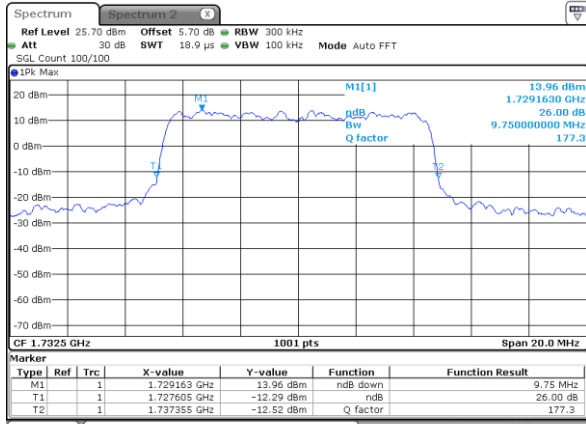

Date: 8.MAR.2024 22:59:35

Middle Channel / 100MHz / 16QAM

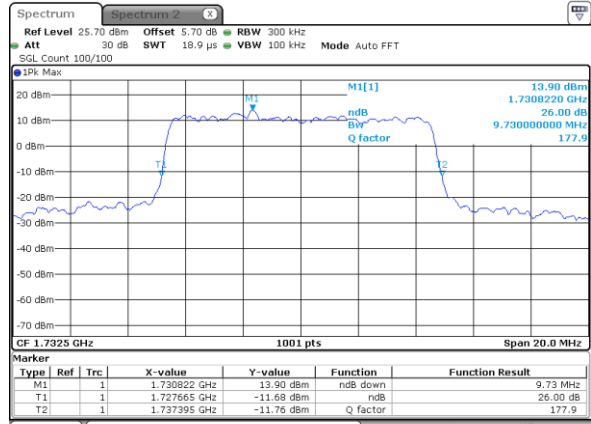

Date: 8.MAR.2024 23:00:01

LTE Band 4

Middle Channel / 15MHz / QPSK

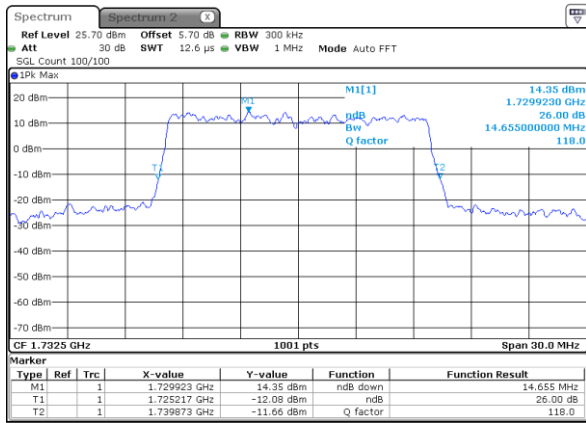

Date: 8.MAR.2024 23:02:13

Middle Channel / 15MHz / 16QAM

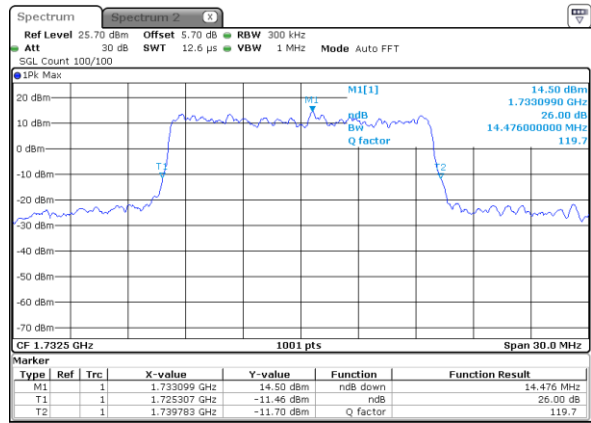

Date: 8.MAR.2024 23:02:39

LTE Band 4

Middle Channel / 20MHz / QPSK

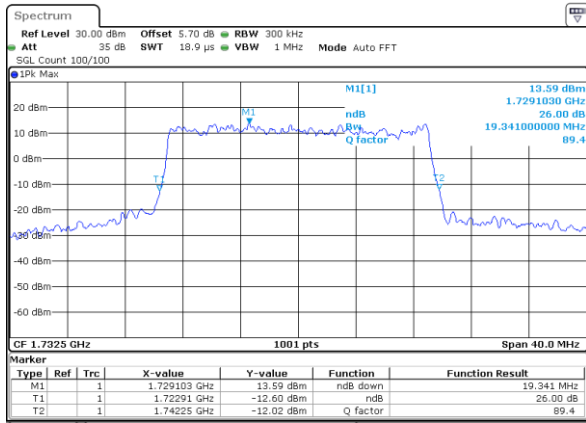

Date: 8.MAR.2024 03:07:51

Middle Channel / 20MHz / 16QAM

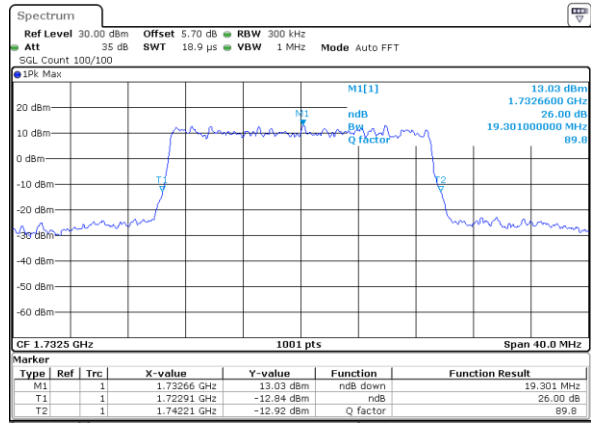

Date: 8.MAR.2024 03:09:27



Occupied Bandwidth

BW	1.4MHz	
Mod.	QPSK	16QAM
Middle CH	1.09	1.09
BW	3MHz	
Mod.	QPSK	16QAM
Middle CH	2.73	2.73
BW	5MHz	
Mod.	QPSK	16QAM
Middle CH	4.50	4.50
BW	10MHz	
Mod.	QPSK	16QAM
Middle CH	9.07	9.07
BW	15MHz	
Mod.	QPSK	16QAM
Middle CH	13.52	13.46
BW	20MHz	
Mod.	QPSK	16QAM
Middle CH	17.90	17.94



LTE Band 4

Middle Channel / 1.4MHz / QPSK

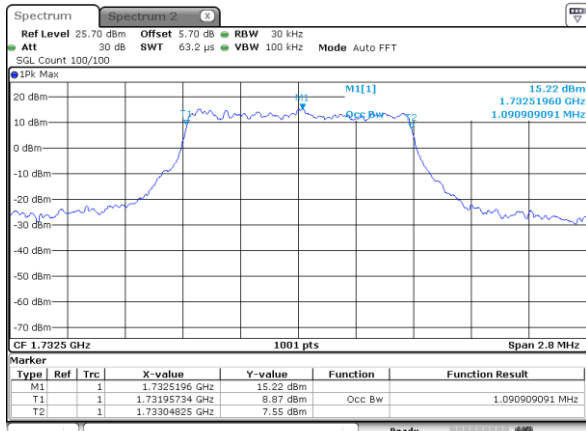

Date: 8.MAR.2024 22:29:28

Middle Channel / 1.4MHz / 16QAM

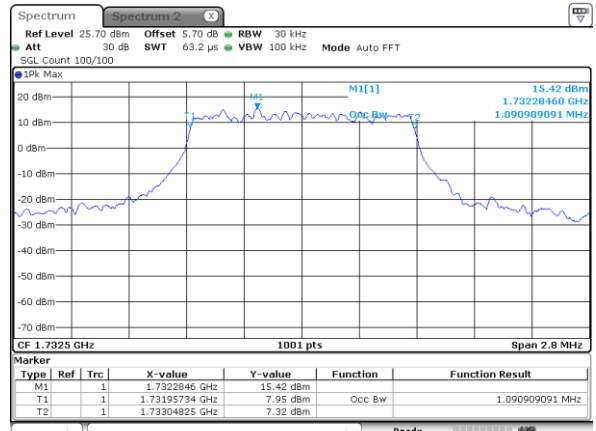

Date: 8.MAR.2024 22:30:24

LTE Band 4

Middle Channel / 3MHz / QPSK

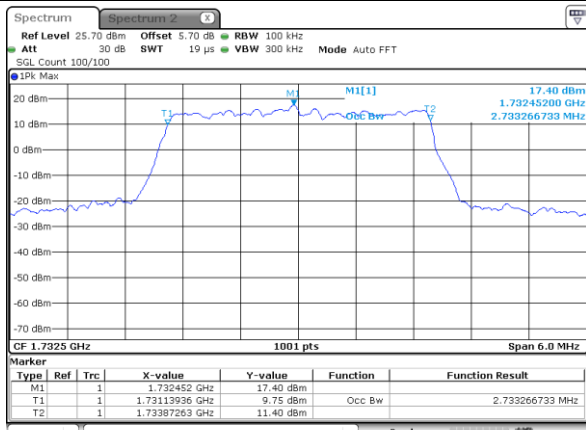

Date: 8.MAR.2024 22:36:15

Middle Channel / 3MHz / 16QAM

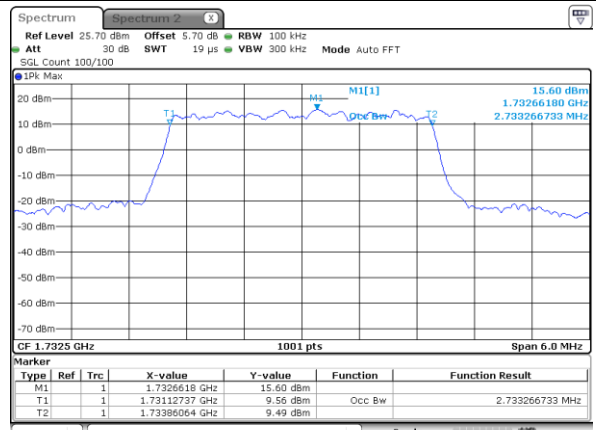

Date: 8.MAR.2024 22:37:10

LTE Band 4

Middle Channel / 5MHz / QPSK

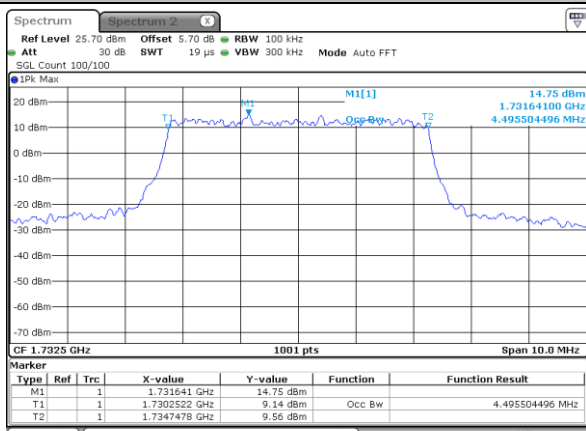

Date: 8.MAR.2024 22:56:44

Middle Channel / 5MHz / 16QAM

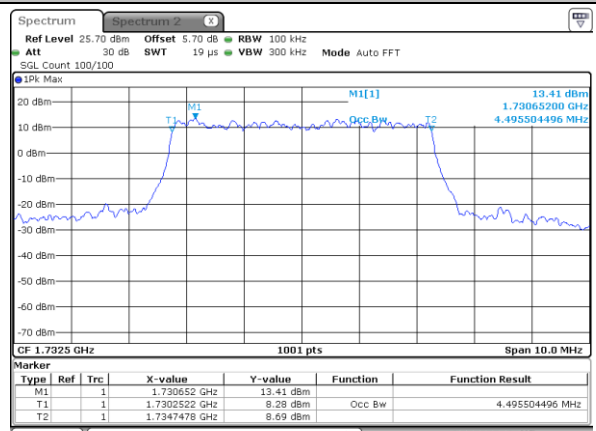

Date: 8.MAR.2024 22:57:39