



# FCC TEST REPORT

FCC ID: 2BELT-Y306

On Behalf of

Aynettek Intelligent Technology (Shenzhen) Co., Ltd

HF RFID Reader

Model No.: Y306, Y308

Prepared for : Aynettek Intelligent Technology (Shenzhen) Co., Ltd  
1010, Zhongchuang Ronghui Center, No. 495, Guangshen  
Address : Avenue, Xintang Town, Zengcheng District, Guangzhou City,  
Guangdong Province

Prepared By : Shenzhen Alpha Product Testing Co., Ltd.  
Address : Building i, No.2, Lixin Road, Fuyong Street, Bao'an District,  
518103, Shenzhen, Guangdong, China

Report Number : A2401001-C02-R05  
Date of Receipt : January 3, 2024  
Date of Test : January 3, 2024 - January 12, 2024  
Date of Report : January 12, 2024  
Version Number : V0  
**Result : Pass**

## Contents

<b>1. General Information</b> .....	<b>5</b>
1.1. Description of Device (EUT) .....	5
1.2. Accessories of Device (EUT).....	6
1.3. Ancillary Equipment Details .....	6
1.4. Test Lab Information .....	6
<b>2. Summary of test</b> .....	<b>7</b>
2.1. Summary of test result.....	7
2.2. Block Diagram.....	7
2.3. Test mode .....	7
2.4. Test Conditions .....	7
2.5. Measurement Uncertainty (95% confidence levels, k=2) .....	8
2.6. Test Equipment .....	9
<b>3. Occupied bandwidth and 20dB Bandwidth</b> .....	<b>10</b>
3.1. Limit.....	10
3.2. Test Procedure.....	10
3.3. Test Setup.....	10
3.4. Test Result.....	10
<b>4. Radiated emissions</b> .....	<b>11</b>
4.1. Limit.....	11
4.2. Block Diagram of Test setup .....	11
4.3. Test Procedure.....	12
4.4. Test Result.....	13
<b>5. Frequency stability</b> .....	<b>18</b>
5.1. Test limit .....	18
5.2. Test Procedure.....	18
5.3. Test Setup.....	18
5.4. Test Results .....	18
<b>6. Power Line Conducted Emissions</b> .....	<b>20</b>
6.1. Block Diagram of Test Setup .....	20
6.2. Limit.....	20
6.3. Test Procedure.....	20
6.4. Test Result.....	21
<b>7. Antenna Requirements</b> .....	<b>23</b>
7.1. Limit.....	23
7.2. Antenna Connected Construction .....	23
7.3. Results .....	23
<b>8. Test setup photo</b> .....	<b>24</b>
8.1. Photos of Radiated emission.....	24
8.2. Photos of Conducted Emission test.....	25

### TEST REPORT DECLARATION

Applicant : Aynettek Intelligent Technology (Shenzhen) Co., Ltd  
 Address : 1010, Zhongchuang Ronghui Center, No. 495, Guangshen Avenue, Xintang  
 Town, Zengcheng District, Guangzhou City, Guangdong Province  
 Manufacturer : Aynettek Intelligent Technology (Shenzhen) Co., Ltd  
 Address : 1010, Zhongchuang Ronghui Center, No. 495, Guangshen Avenue, Xintang  
 Town, Zengcheng District, Guangzhou City, Guangdong Province  
 EUT Description : HF RFID Reader  
 (A) Model No. : Y306, Y308  
 (B) Trademark : **AYNETTEK**

Measurement Standard Used:

**FCC Rules and Regulations Part 15 Subpart C Section 15.225  
ANSI C63.10:2013**

The device described above is tested by Shenzhen Alpha Product Testing Co., Ltd. to determine the maximum emission levels emanating from the device and the severe levels of the device can endure and its performance criterion. The test results are contained in this test report and Shenzhen Alpha Product Testing Co., Ltd. is assumed full responsibility for the accuracy and completeness of test. Also, this report shows that the EUT is technically compliant with the FCC Part15 requirements.

This report applies to above tested sample only. This report shall not be reproduced in parts without written approval of Shenzhen Alpha Product Testing Co., Ltd.

Tested by (name + signature).....: Yannis Wen  
 Project Engineer 

Approved by (name + signature).....: Reak Yang  
 Project Manager 

Date of issue..... : January 12, 2024

### Revision History

Revision	Issue Date	Revisions	Revised By
V0	January 12, 2024	Initial released Issue	Yannis Wen

# 1. General Information

## 1.1. Description of Device (EUT)

EUT : HF RFID Reader

Model No. : Y306, Y308

DIFF : There is no difference except for the appearance and model name.  
All tests are made with the Y306 model.

Power supply : DC 24V from adapter.

### NFC

Operation frequency : 13.56MHz

Channel No. : 1 Channel

Modulation : ASK

Antenna Type : Coil antenna, max gain 0dBi  
(Antenna information is provided by applicant.)

Software version : V1.0

Hardware version : V1.0

## 1.2. Accessories of Device (EUT)

Accessories	:	SWITCHING ADAPTOR
Manufacturer	:	SuZhou MEAN WELL Technology Co., Ltd.
Model	:	GST40A24
Input	:	100-240VAC, 50/60Hz, 1.0A
Output	:	24V=1.67A, 40W MAX

## 1.3. Ancillary Equipment Details

No.	Description	Manufacturer	Model	Serial Number	Certification or SDOC
1.	Notebook	ThinkPad	E14	N/A	N/A

## 1.4. Test Lab Information

Shenzhen Alpha Product Testing Co., Ltd

Building i, No.2, Lixin Road, Fuyong Street, Bao'an District, 518103,  
Shenzhen, Guangdong, China

June 21, 2018 File on Federal Communication Commission  
Registration Number: 293961

July 15, 2019 Certificated by IC  
Registration Number: 12135A

## 2. Summary of test

### 2.1. Summary of test result

Description of Test Item	Standard	Results
Conducted Emission	15.207(a)	Pass
Radiated emissions	15.209(a)&15.225	Pass
Fundamental field strength limit	15.225(a)	Pass
Frequency stability	15.225(e)	Pass
Band edge compliance	15.225	Pass
Antenna Requirement	15.203	Pass

Note: The conclusion of this test report is judged by actual test data without considering measurement uncertainty.

### 2.2. Block Diagram

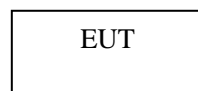

### 2.3. Test mode

Tested mode, channel, and data rate information		
Mode	Channel	Frequency (MHz)
1	CH1	13.56

Note: According exploratory test, EUT will have maximum output power in those data rate. so those data rate were used for all test.

### 2.4. Test Conditions

Temperature range	21-25°C
Humidity range	40-75%
Pressure range	86-106kPa

## 2.5. Measurement Uncertainty (95% confidence levels, k=2)

Item	Uncertainty
Uncertainty for Power point Conducted Emissions Test	2.74dB
Uncertainty for Radiation Emission test in 3m chamber (below 30MHz)	2.13 dB(Polarize: V)
	2.57dB(Polarize: H)
Uncertainty for Radiation Emission test in 3m chamber (30MHz to 1GHz)	3.77dB(Polarize: V)
	3.80dB(Polarize: H)
Uncertainty for Radiation Emission test in 3m chamber (1GHz to 25GHz)	4.16dB(Polarize: H)
	4.13dB(Polarize: V)
Uncertainty for radio frequency	$5.4 \times 10^{-8}$
Uncertainty for conducted RF Power	0.37dB
Uncertainty for temperature	0.2°C
Uncertainty for humidity	1%
Uncertainty for DC and low frequency voltages	0.06%



## 2.6. Test Equipment

Equipment	Manufacture	Model No.	Firmware version	Serial No.	Last cal.	Cal Interval
9*6*6 anechoic chamber	CHENYU	9*6*6	/	N/A	2022.05.17	3Year
Spectrum analyzer	ROHDE&SCHWARZ	FSV40-N	2.3	102137	2023.08.16	1Year
Spectrum analyzer	Agilent	N9020A	A.14.16	MY499100060	2023.08.16	1Year
Receiver	ROHDE&SCHWARZ	ESR	2.28 SP1	1316.3003K03-10 2082-Wa	2023.08.16	1Year
Receiver	R&S	ESCI	4.42 SP1	101165	2023.08.16	1Year
Bilog Antenna	Schwarzbeck	VULB 9168	/	VULB 9168#627	2023.08.28	1Year
Horn Antenna	SCHWARZBECK	BBHA 9120 D	/	2106	2023.08.19	1Year
Loop Antenna	SCHWARZBECK	FMZB 1519B	/	00128	2023.08.19	1Year
RF Cable	Resenberger	Cable 1	/	RE1	2023.08.16	1Year
RF Cable	Resenberger	Cable 2	/	RE2	2023.08.16	1Year
RF Cable	Resenberger	Cable 3	/	CE1	2023.08.16	1Year
Pre-amplifier	HP	HP8347A	/	2834A00455	2023.08.16	1Year
Pre-amplifier	Agilent	8449B	/	3008A02664	2023.08.16	1Year
L.I.S.N.#1	Schwarzbeck	NSLK8126	/	8126-466	2023.08.16	1Year
L.I.S.N.#2	ROHDE&SCHWARZ	ENV216	/	101043	2023.08.16	1Year
Horn Antenna	SCHWARZBECK	BBHA 9170	/	00946	2023.08.19	1Year
Preamplifier	SKET	LNPA_1840 -50	/	SK2018101801	2023.08.16	1 Year
Power Meter	Agilent	E9300A	/	MY41496628	2023.08.16	1 Year
Power Sensor	DARE	RPR3006W	/	15100041SNO91	2023.08.16	1 Year
Temp. & Humid. Chamber	Teelong	TL-HW408S	/	TL-20191205-01	2023.07.25	1 Year
Switching Mode Power Supply	JUNKE	JK12010S	/	20140927-6	2023.08.16	1 Year
Adjustable attenuator	MWRFTest	N/A	/	N/A	N/A	N/A
10dB Attenuator	Mini-Circuits	DC-6G	/	N/A	N/A	N/A

Software Information			
Test Item	Software Name	Manufacturer	Version
RE	EZ-EMC	farad	Alpha-3A1
CE	EZ-EMC	farad	Alpha-3A1
RF-CE	MTS 8310	MWRFTest	2.0.0.0

### 3. Occupied bandwidth and 20dB Bandwidth

#### 3.1. Limit

Intentional radiators operating under the alternative provisions to the general emission limits, as contained in FCC part 15.217 through 15.257 and in Subpart E of this part, must be designed to ensure that the 20 dB bandwidth of the emission, or whatever bandwidth may otherwise be specified in the specific rule section under which the equipment operates, is contained within the frequency band designated in the rule section under which the equipment is operated.

#### 3.2. Test Procedure

The transmitter output was directly connected to a spectrum analyzer with a 50Ω cable. The bandwidth of the fundamental frequency was measured by spectrum analyzer with 3KHz RBW and 10kHz VBW. The 20dB bandwidth is defined as the total spectrum the power of which is higher than peak power minus 20dB.

#### 3.3. Test Setup

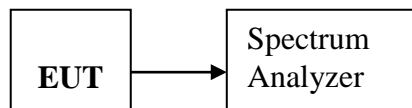

#### 3.4. Test Result

Mode	Freq (MHz)	20dB Bandwidth (KHz)	99% Bandwidth	Limit (kHz)	Conclusion
Tx Mode	13.56	11.19	50.924	/	Pass

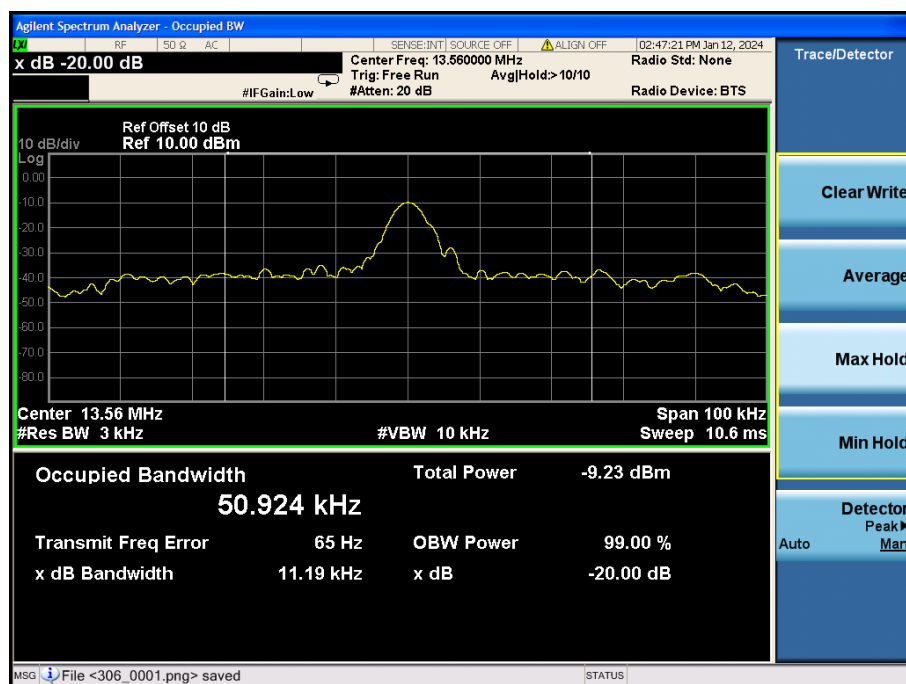

## 4. Radiated emissions

### 4.1. Limit

Frequency (MHz)	Field Strength		Field Strength Limit at 3m Measurement Dist	
	uV/m	Distance (m)	uV/m	dBuV/m
0.009 ~ 0.490	2400/F(kHz)	300	10000 * 2400/F(kHz)	$20\log^{(2400/F(kHz))} + 80$
0.490 ~ 1.705	24000/F(kHz)	30	100 * 24000/F(kHz)	$20\log^{(24000/F(kHz))} + 40$
1.705 ~ 30	30	30	100 * 30	$20\log^{(30)} + 40$
30 ~ 88	100	3	100	$20\log^{(100)}$
88 ~ 216	150	3	150	$20\log^{(150)}$
216 ~ 960	200	3	200	$20\log^{(200)}$
Above 960	500	3	500	$20\log^{(500)}$

Note:

- a) The tighter limit applies at the band edges.

For example: F.S limit at 88MHz is 100uV/m

- b) If measurement is made at 3m distance, then F.S Limit at 3m distance is adjusted by using the formula of  $L_{d1} = L_{d2} * (d2/d1)^2$ .

For example:

F.S Limit at 30m(d2) distance is 30uV/m(L<sub>d2</sub>), then F.S Limit at 3m(d1) distance is

$$L_{d1} = 30\text{uV/m} * (30/3)^2 = 100 * 30\text{uV/m} = 69.54 \text{ dBuV/m}$$

- (a) The field strength of any emissions within the band 13.553-13.567 MHz shall not exceed 15,848 microvolts/meter at 30 meters.

- (b) Within the bands 13.410-13.553 MHz and 13.567-13.710 MHz, the field strength of any emissions shall not exceed 334 microvolts/meter at 30 meters.

- (c) Within the bands 13.110-13.410 MHz and 13.710-14.010 MHz the field strength of any emissions shall not exceed 106 microvolts/meter at 30 meters.

- (d) The field strength of any emissions appearing outside of the 13.110-14.010 MHz band shall not exceed the general radiated emission limits in §15.209.

### 4.2. Block Diagram of Test setup

In 3m Anechoic Chamber Test Setup Diagram for below 30MHz

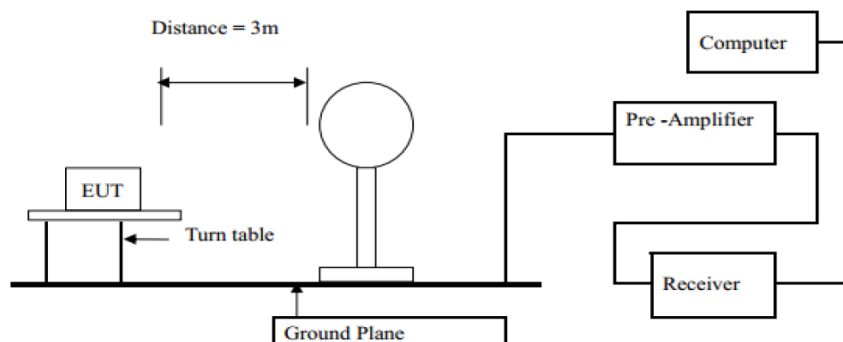

In 3m Anechoic Chamber Test Setup Diagram for frequency 30MHz-1GHz

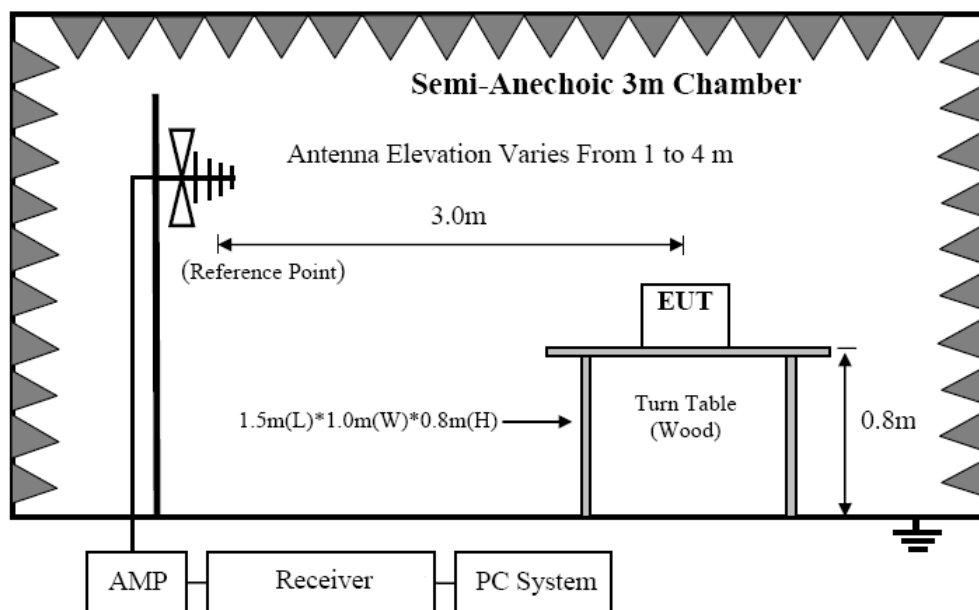

### 4.3. Test Procedure

#### Procedure of Preliminary Test

The EUT and Support equipment, if needed, were put placed on a non-metallic table, 80cm above the ground plane.

Configuration EUT to simulate typical usage as described in clause 2.4 and test equipment as described in clause 4.2 of this report.

All I/O cables were positioned to simulate typical actual usage as per ANSI C63.10:2013.

Mains cables, telephone lines or other connections to auxiliary equipment located outside the test are shall drape to the floor, be fitted with ferrite clamps or ferrite tubes placed on the floor at the point where the cable reaches the floor and then routed to the place where they leave the turntable. No extension cords shall be used to mains receptacle.

The antenna was placed at 3 meter away from the EUT as stated in ANSI C63.10:2013. The antenna connected to the Spectrum Analyzer via a cable and at times a pre-amplifier would be used.

The Receiver quickly scanned from 9KHz to 30MHz and 30MHz to 1GHz The EUT test program was started. Emissions were scanned and measured rotating the EUT to 360 degrees and positioning the antenna 1 to 4 meters above the ground plane, in both the vertical and the horizontal polarization, to maximize the emission reading level.

The test mode(s) described in clause 2.4 were scanned during the preliminary test:

After the preliminary scan, we found the test mode producing the highest emission level. The EUT and cable configuration, antenna position, polarization and turntable position of the above highest emission level were recorded for the final test.

#### Procedure of Final Test

EUT and support equipment were set up on the turntable as per the configuration with highest emission level in the preliminary test.

The Receiver scanned from 9KHz to 30MHz and 30MHz to 1GHz. Emissions were scanned and measured rotating the EUT to 360 degrees, varying cable placement and

positioning the antenna 1 to 4 meters above the ground plane, in both the vertical and the horizontal polarization, to maximize the emission reading level.

Recorded at least the six highest emissions. Emission frequency, amplitude, antenna position, polarization and turntable position were recorded into a computer in which correction factors were used to calculate the emission level and compare reading to the applicable limit and only Q.P. reading is presented.

The test data of the worst-case condition(s) was recorded.

The bandwidth of test receiver is set at 200Hz for 9 KHz to 150 KHz measure, 10 KHz for 150 KHz to 30MHz measure and 120 KHz for 30 MHz to 1GHz measure .

#### 4.4. Test Result

Pass. (See below detailed test result)

Detailed information please see the following page.

From 9KHz to 30MHz: Conclusion: Pass

Frequency Range	: 9KHz~30MHz
Test Mode	: TX: 13.56MHz
Test Results	: <b>Pass</b>
Note:	<ol style="list-style-type: none"> <li>1. The test results are listed in next pages.</li> <li>2. This mode is worst case mode, so this report only reflected the worst mode.</li> <li>3. If the limits for the measurement with the average detector are met when using a receiver with a peak detector, the test unit shall be deemed to meet both limits and the measurement with the quasi-peak detector need not be carried out.</li> </ol>

X:

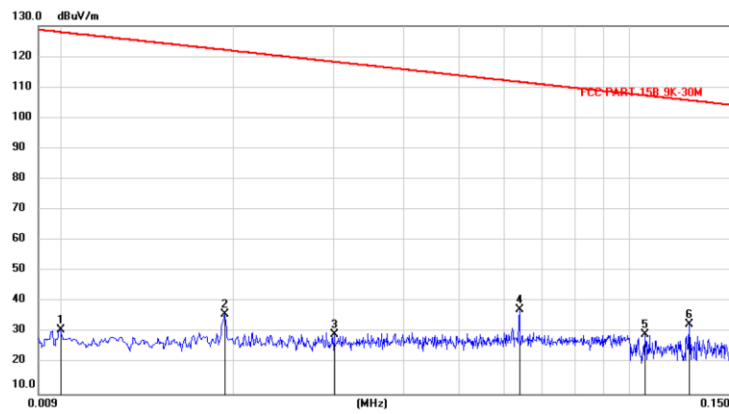

No.	Mk.	Freq.	Reading Level	Correct Factor	Measurement	Limit	Margin	Antenna Height	Table Degree	
		MHz	dBuV	dB	dBuV/m	dBuV/m	dB	cm	degree	Comment
1		0.0098	9.34	21.50	30.84	127.9	-97.12			peak
2		0.0192	14.71	21.27	35.98	122.1	-86.14			peak
3		0.0301	8.36	20.99	29.35	118.2	-88.87			peak
4		0.0638	17.42	20.11	37.53	111.7	-74.17			peak
5		0.1067	9.72	19.73	29.45	107.2	-77.78			peak
6	*	0.1276	12.64	19.88	32.52	105.6	-73.16			peak

Note: 1. \*:Maximum data; x:Over limit; !:over margin.  
 2.Measurement=Reading Level+Correct Factor; Correct Factor=Antenna Factor+Cable Loss.

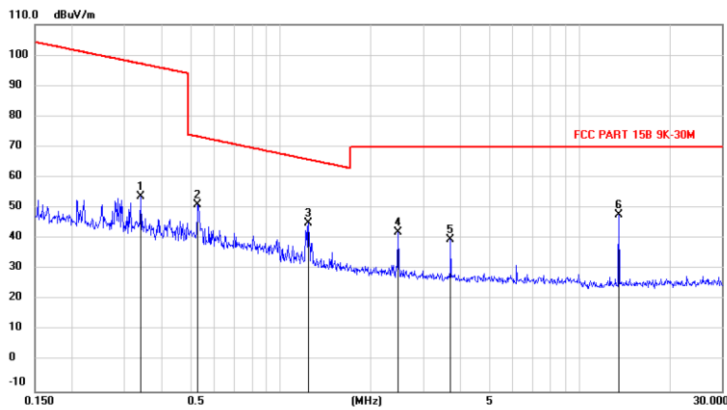

No.	Mk.	Freq.	Reading Level	Correct Factor	Measurement	Limit	Margin	Antenna Height	Table Degree	
		MHz	dBuV	dB	dBuV/m	dBuV/m	dB	cm	degree	Comment
1		0.3407	33.75	19.93	53.68	97.16	-43.48			peak
2		0.5287	31.45	19.72	51.17	73.33	-22.16			peak
3	*	1.2362	24.93	20.06	44.99	65.84	-20.85			peak
4		2.4688	21.78	20.37	42.15	70.00	-27.85			peak
5		3.7073	18.73	20.89	39.62	70.00	-30.38			peak
6		13.5604	27.12	20.64	47.76	70.00	-22.24			peak

Note: 1. \*:Maximum data; x:Over limit; !:over margin.  
 2.Measurement=Reading Level+Correct Factor; Correct Factor=Antenna Factor+Cable Loss.

From 30MHz to 1GHz: Conclusion: Pass

**Vertical:**

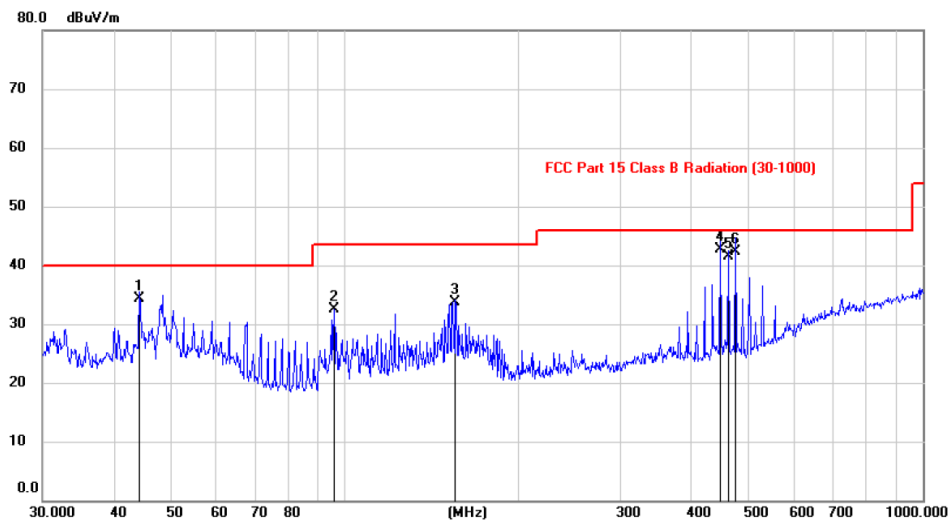

No.	Mk.	Freq.	Reading Level	Correct Factor	Measurement	Limit	Margin	Antenna Height	Table Degree	
		MHz	dBuV	dB	dBuV/m	dBuV/m	dB	cm	degree	Comment
1		44.2287	20.07	14.20	34.27	40.00	-5.73			QP
2		96.0424	21.89	10.54	32.43	43.50	-11.07			peak
3		155.8553	18.73	15.05	33.78	43.50	-9.72			QP
4	*	447.5112	25.28	17.51	42.79	46.00	-3.21			QP
5		461.0504	23.92	17.67	41.59	46.00	-4.41			QP
6		474.6107	24.51	17.85	42.36	46.00	-3.64			QP

Note: 1. \*:Maximum data; x:Over limit; !:over margin.

2.Measurement=Reading Level+Correct Factor; Correct Factor=Antenna Factor+Cable Loss.

Horizontal:

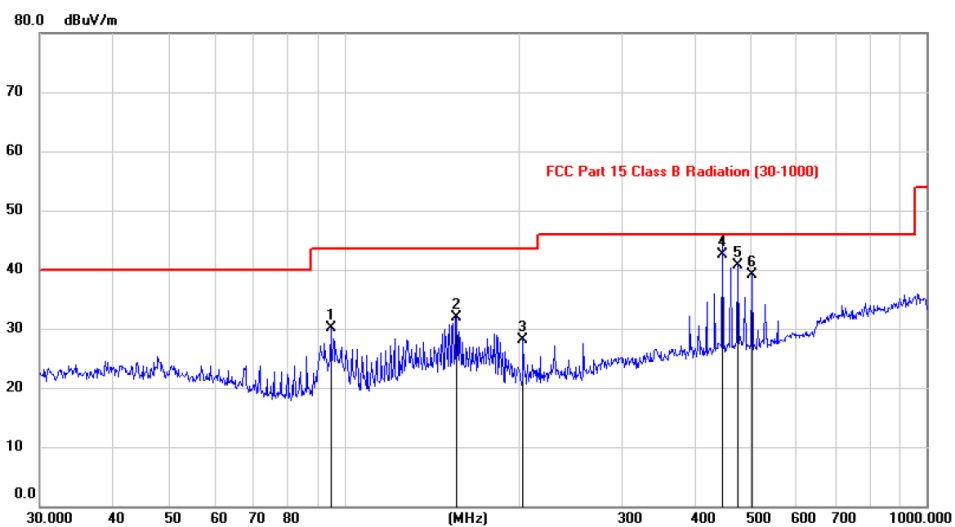

No.	Mk.	Freq.	Reading Level	Correct Factor	Measurement	Limit	Margin	Antenna Height	Table Degree	
		MHz	dBuV	dB	dBuV/m	dBuV/m	dB	cm	degree	Comment
1		94.9041	19.51	10.51	30.02	43.50	-13.48			peak
2		155.9101	16.84	15.05	31.89	43.50	-11.61			peak
3		203.4038	17.14	10.96	28.10	43.50	-15.40			peak
4	*	447.5111	25.06	17.51	42.57	46.00	-3.43			QP
5		474.6106	22.84	17.85	40.69	46.00	-5.31			QP
6		501.7651	20.91	18.24	39.15	46.00	-6.85			peak

Note: 1. \*:Maximum data; x:Over limit; !:over margin.

2.Measurement=Reading Level+Correct Factor; Correct Factor=Antenna Factor+Cable Loss.



## Field Strength Emissions Result

Temperature		24°C			Relative Humidity		56%	
Pressure		960hPa			Distance		3m	
Test Mode		TX						
Freq. (MHz)	Position H/V	Detector Mode (PK/QP)	Reading (dBuV)	Factor (dB)	Actual FS (dBuV/m)	Limits 3m (dBuV/m)	Margin (dBuV/m)	
13.560	H	Peak	80.56	-13.94	66.62	124	-57.38	
13.560	H	AV	77.73	-13.94	63.79	104	-40.21	
13.110	H	Peak	51.13	-13.94	37.19	80.5	-43.31	
13.410	H	Peak	51.01	-13.94	37.07	90.5	-53.43	
13.553	H	Peak	48.18	-13.94	34.24	90.5	-56.26	
13.567	H	Peak	45.73	-13.93	31.80	90.5	-58.70	
13.710	H	Peak	43.79	-13.93	29.86	80.5	-50.64	
14.010	H	Peak	43.93	-13.93	30.00	80.5	-50.50	
Freq. (MHz)	Position H/V	Detector Mode (PK/QP)	Reading (dBuV)	Factor (dB)	Actual FS (dBuV/m)	Limits 3m (dBuV/m)	Margin (dBuV/m)	
13.560	V	Peak	81.75	-13.94	67.81	124	-56.19	
13.560	V	AV	77.06	-13.94	63.12	104	-40.88	
13.110	V	Peak	50.17	-13.94	36.23	80.5	-44.27	
13.410	V	Peak	51.49	-13.94	37.55	90.5	-52.95	
13.553	V	Peak	48.86	-13.94	34.92	90.5	-55.58	
13.567	V	Peak	45.67	-13.93	31.74	90.5	-58.76	
13.710	V	Peak	44.35	-13.93	30.42	80.5	-50.08	
14.010	V	Peak	44.44	-13.93	30.51	80.5	-49.99	

Note:

1: 30m to 3m correction factor calculation:  
 $40 * \log(30m/3m) = 40$

2: --Means other frequency and mode comply with standard requirements and at least have 20dB margin.

3: Correct Factor=Cable Loss+ Antenna Factor- Amplifier Gain  
 Measurement Result=Reading + Correct Factor  
 Margin=Measurement Result-Limit

## 5. Frequency stability

### 5.1. Test limit

Please refer section RSS-Gen & 15.225e.

Regulation 15.225(e) The frequency tolerance of the carrier signal shall be maintained within  $\pm 0.01\%$  ( $\pm 100$  ppm) of the operating frequency over a temperature variation of  $-20$  degrees to  $+50$  degrees C at normal supply voltage, and for a variation in the primary supply voltage from 85% to 115% of the rated supply voltage at a temperature of 20 degrees C. For battery operated equipment, the equipment tests shall be performed using a new battery.

### 5.2. Test Procedure

The following equipment are installed on the emission measurement to meet the commission requirements and operating regulations in a manner which tends to maximize its emission characteristics in normal application.

### 5.3. Test Setup

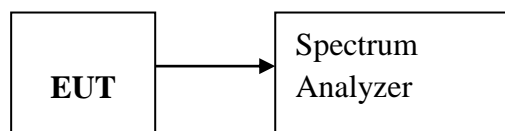

### 5.4. Test Results

**Pass.**

Detailed information please see the following page.

Assigned Frequency(MHz): 13.56MHz				
Voltage	Temperature	Measured Frequency (MHz)	Frequency stability	Limit
Low DC 3.3V	+20°C	13.560830	0.000830	±100 ppm ±0.001356MHz
Normal DC 3.80V	-10°C	13.560568	0.000568	
	-5°C	13.560582	0.000582	
	0°C	13.560393	0.000393	
	+10°C	13.560385	0.000385	
	+20°C	13.560658	0.000658	
	+30°C	13.560352	0.000352	
	+40°C	13.559970	-0.000030	
	+50°C	13.560387	0.000387	
High DC 4.4V	+60°C	13.560421	0.000421	
	+20°C	13.560830	0.000830	

## 6. Power Line Conducted Emissions

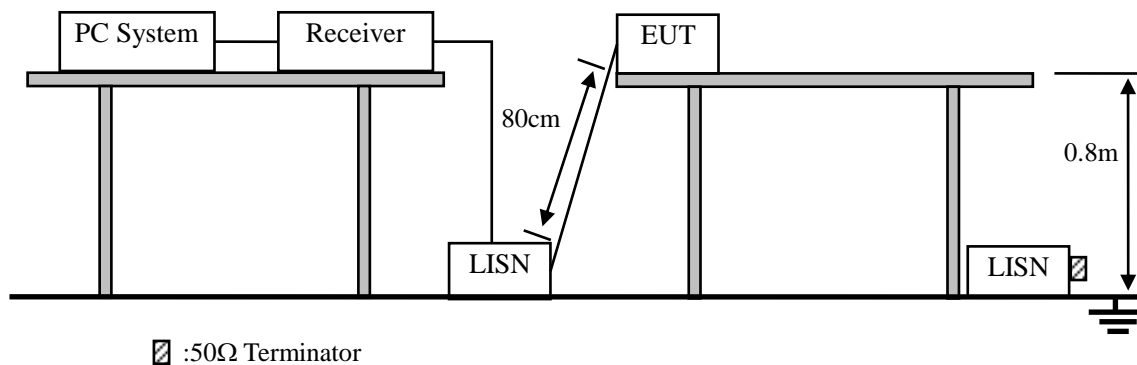

### 6.1. Block Diagram of Test Setup

### 6.2. Limit

Frequency	Maximum RF Line Voltage	
	Quasi-Peak Level dB( $\mu$ V)	Average Level dB( $\mu$ V)
150kHz ~ 500kHz	66 ~ 56*	56 ~ 46*
500kHz ~ 5MHz	56	46
5MHz ~ 30MHz	60	50

Notes: 1. \* Decreasing linearly with logarithm of frequency.

2. The lower limit shall apply at the transition frequencies.

### 6.3. Test Procedure

- (1) The EUT was placed on a non-metallic table, 80cm above the ground plane.
- (2) Setup the EUT and simulator as shown in 10.1
- (3) The EUT Power connected to the power mains through a power adapter and a line impedance stabilization network (L.I.S.N1). The other peripheral devices power cord connected to the power mains through a line impedance stabilization network (L.I.S.N1), this provided a 50-ohm coupling impedance for the EUT (Please refer to the block diagram of the test setup and photographs). Both sides of power line were checked for maximum conducted interference. In order to find the maximum emission, the relative positions of equipments and all of the interface cables were changed according to ANSI C64.10:2013 on conducted Emission test.
- (4) The bandwidth of test receiver is set at 10KHz.
- (5) The frequency range from 150 KHz to 30MHz is checked.

### 6.4. Test Result

Pass. (See below detailed test data)

Note: If peak Result comply with AV limit, QP and AV Result is deemed to comply with AV limit

Line:

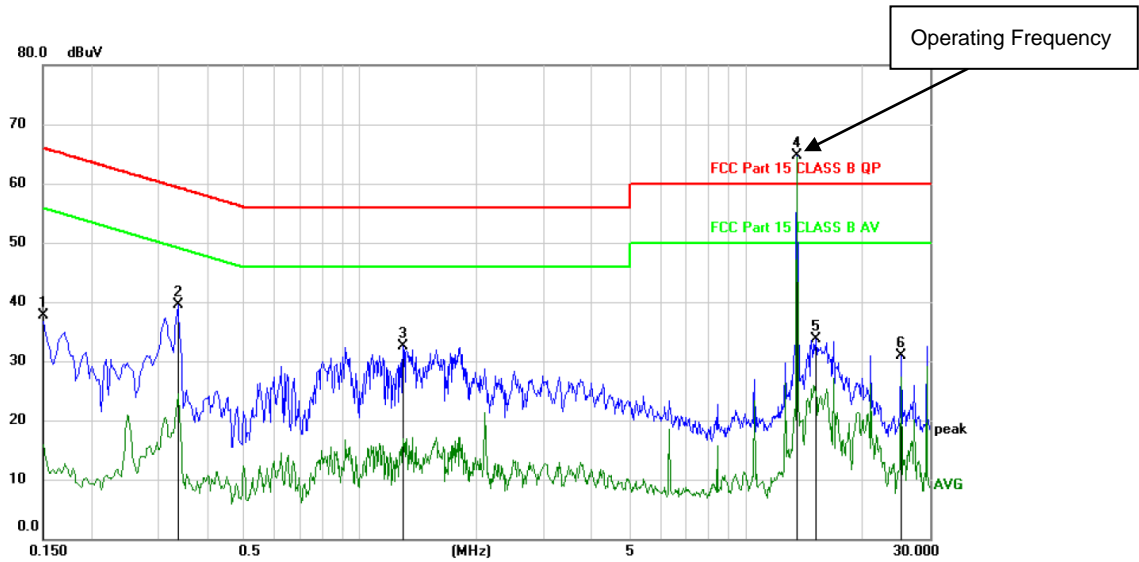

No.	Mk.	Freq. MHz	Reading Level dBuV	Correct Factor dB	Measure- ment dBuV	Limit dBuV	Margin dB	Detector	Comment
1		0.1500	27.66	10.07	37.73	66.00	-28.27	peak	
2		0.3360	29.37	10.15	39.52	59.30	-19.78	peak	
3		1.2960	22.13	10.42	32.55	56.00	-23.45	peak	
4	*	13.5600	53.86	10.91	64.77	60.00	4.77	peak	
5		15.1590	22.68	10.95	33.63	60.00	-26.37	peak	
6		25.3020	19.98	10.99	30.97	60.00	-29.03	peak	

\*:Maximum data x:Over limit !:over margin (Reference Only)

Note: Measurement=Reading Level+Correc Factor. Factor=(LISN or ISN or PLC or Current Probe)Factor+Cable

**Neutral:**

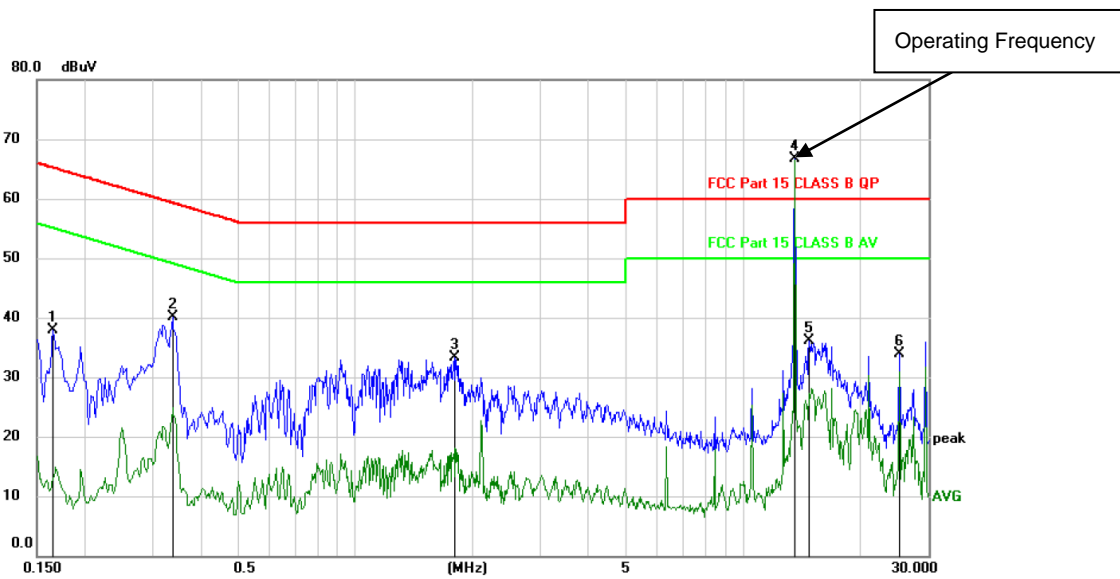

No.	Mk.	Freq.	Reading Level	Correct Factor	Measurement	Limit	Margin	Detector	Comment
		MHz	dBuV	dB	dBuV	dBuV	dB		
1		0.1650	27.80	10.05	37.85	65.21	-27.36	peak	
2		0.3360	29.91	10.15	40.06	59.30	-19.24	peak	
3		1.7910	22.85	10.41	33.26	56.00	-22.74	peak	
4	*	13.5600	55.87	10.91	66.78	60.00	6.78	peak	
5		14.7660	25.16	10.94	36.10	60.00	-23.90	peak	
6		25.3050	22.96	10.99	33.95	60.00	-26.05	peak	

\*:Maximum data    x:Over limit    !:over margin    (Reference Only)  
 Note: Measurement=Reading Level+Correc Factor.    Factor=(LISN or ISN or PLC or Current Probe)Factor+Cable

## **7. Antenna Requirements**

### **7.1. Limit**

For intentional device, according to RSS-Gen Section 6.8 and FCC 47 CFR Section 15.203, an intentional radiator shall be designed to ensure that no antenna other than that furnished by the responsible party shall be used with the device. And according to FCC 47 CFR Section 15.209, if transmitting antennas of directional gain greater than 6dBi are used, the power shall be reduced by the amount in dB that the directional gain of the antenna exceeds 6dBi.

### **7.2. Antenna Connected Construction**

The antenna is internal antenna and no consideration of replacement. Please see EUT photo for details.

### **7.3. Results**

The EUT antenna is Internal Antenna. It complies with the standard requirement.

## 8. Test setup photo

### 8.1. Photos of Radiated emission

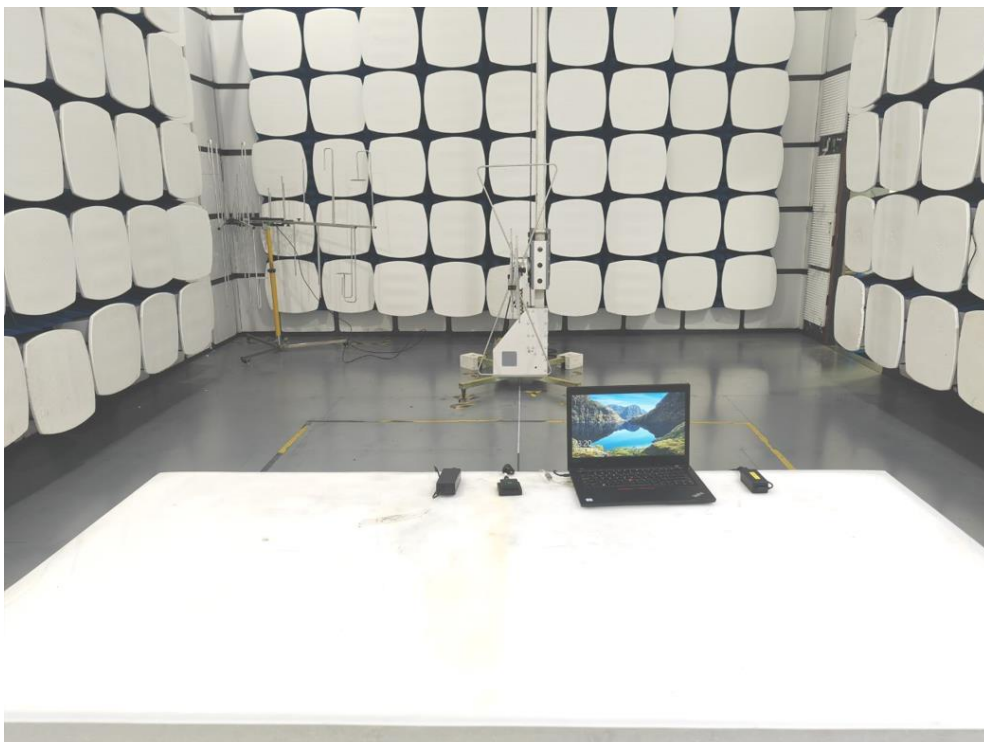
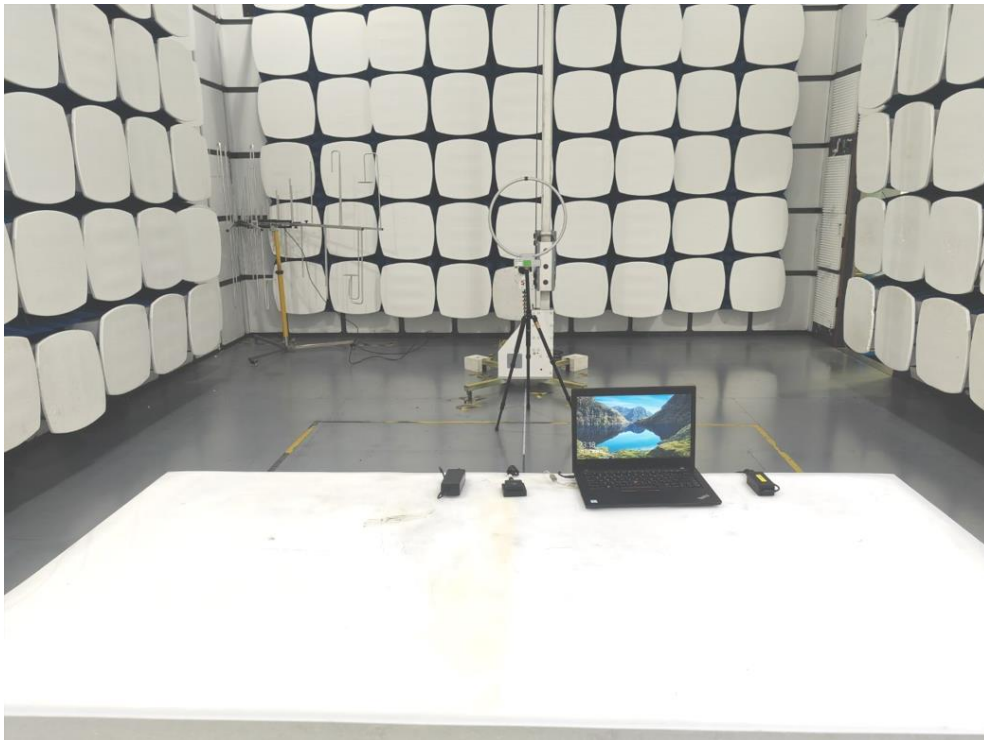



## 8.2. Photos of Conducted Emission test

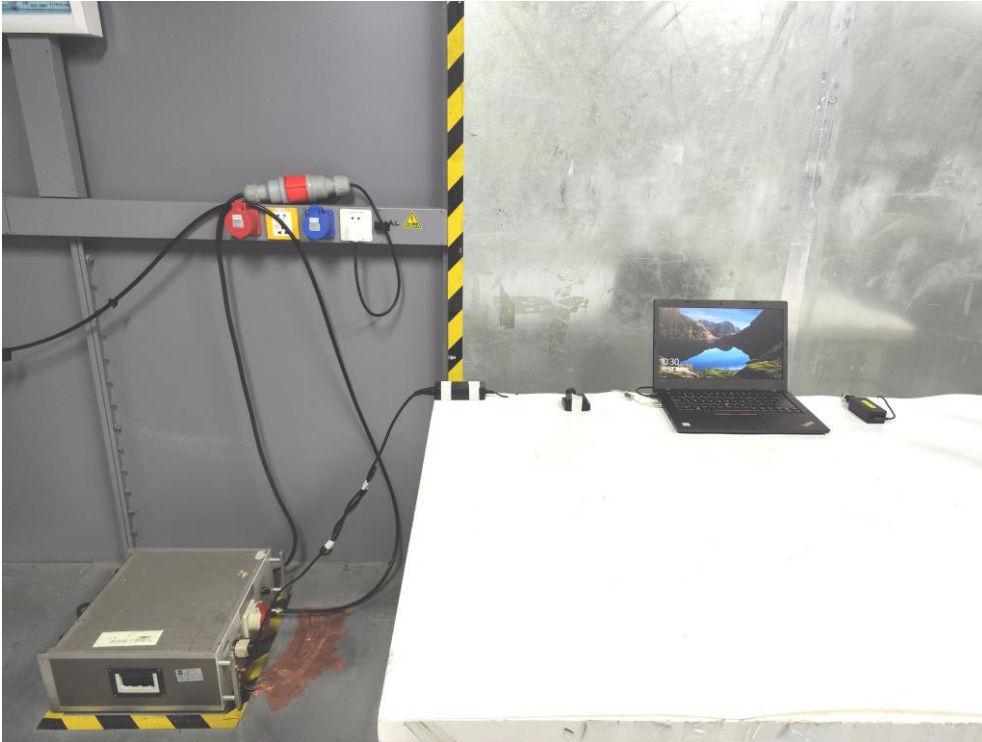

-----THE END OF REPORT-----