



Shenzhen CTA Testing Technology Co., Ltd.

Room 106, Building 1, Yibaolai Industrial Park, Qiaotou Community, Fuhai Street, Bao'an District, Shenzhen, China

TEST REPORT

FCC Part 22 Subpart H / Part 24 Subpart E/ Part 27

Report Reference No.....: CTA24052000602

FCC ID.....: 2BE8S-F24

Compiled by

(position+printed name+signature) :: File administrators Jinghua Xiao

Supervised by

(position+printed name+signature) :: Project Engineer Zoey Cao

Approved by

(position+printed name+signature) :: RF Manager Eric Wang

Date of issue.....: May 28, 2024



Testing Laboratory Name: Shenzhen CTA Testing Technology Co., Ltd.

Address: Room 106, Building 1, Yibaolai Industrial Park, Qiaotou Community, Fuhai Street, Bao'an District, Shenzhen, China

Applicant's name: Shenzhen kehuitong Technology Co., Ltd.

Address: F3.830306G, 3rd Floor, Tianan Code City Tianjing Building, No.6 Tianan Road, Shatou Street, Futian District, Shenzhen China

Test specification

Standard: FCC CFR Title 47 Part 2, Part 22H, Part 24E and Part 27

ANSI/TIA-603-E-2016

KDB 971168 D01

Shenzhen CTA Testing Technology Co., Ltd. All rights reserved.

This publication may be reproduced in whole or in part for non-commercial purposes as long as the Shenzhen CTA Testing Technology Co., Ltd. is acknowledged as copyright owner and source of the material. Shenzhen CTA Testing Technology Co., Ltd. takes no responsibility for and will not assume liability for damages resulting from the reader's interpretation of the reproduced material due to its placement and context.

Test item description.....: mobile phone

Trade Mark: Aidekunlin

Manufacturer: Shenzhen kehuitong Technology Co., Ltd.

Model/Type reference.....: F24

Listed Models: Refer to page 2

Ratings: DC 3.85V From battery and DC 5.0V From external circuit

Modulation: QPSK

Frequency.....: UMTS Band II, UMTS Band IV, UMTS Band V

Result.....: PASS

TEST REPORT

Equipment under Test : mobile phone

Model /Type : F24

Listed Models : F25,F26,F27,F28,F29,F30,F31,F32,F33,F34,F35,F70,F70U,F80, F80U,F90,F90U,F60,F12pro,F13pro,F14pro,F27pro,F100,F200, F300,F400,F500,F600,F700,M200,M210,M220,M230,M240,M250, M260,M270,M280,M290,M300,M70,M70U,M80,M80U,M90,M90U, M66,M66pro,M55,M55U,M58,

Applicant : **Shenzhen kehuitong Technology Co., Ltd.**

Address : F3.830306G, 3rd Floor, Tianan Code City Tianjing Building, No.6 Tianan Road, Shatou Street, Futian District, Shenzhen China

Manufacturer : **Shenzhen kehuitong Technology Co., Ltd.**

Address : F3.830306G, 3rd Floor, Tianan Code City Tianjing Building, No.6 Tianan Road, Shatou Street, Futian District, Shenzhen China

| | |
|--------------------|---------------|
| Test result | Pass * |
|--------------------|---------------|

* In the configuration tested, the EUT complied with the standards specified page 4.

The test report merely corresponds to the test sample.

It is not permitted to copy extracts of these test result without the written permission of the test laboratory.

Contents

| | | |
|----------|--|-----------|
| 1 | SUMMARY | 4 |
| 1.1 | TEST STANDARDS | 4 |
| 1.2 | TEST DESCRIPTION | 4 |
| 1.3 | ADDRESS OF THE TEST LABORATORY | 4 |
| 1.4 | TEST FACILITY | 4 |
| 1.5 | STATEMENT OF THE MEASUREMENT UNCERTAINTY | 5 |
| 2 | GENERAL INFORMATION | 6 |
| 2.1 | ENVIRONMENTAL CONDITIONS | 6 |
| 2.2 | GENERAL DESCRIPTION OF EUT | 6 |
| 2.3 | DESCRIPTION OF TEST MODES AND TEST FREQUENCY | 7 |
| 2.4 | EQUIPMENTS USED DURING THE TEST | 8 |
| 2.5 | RELATED SUBMITTAL(S) / GRANT (S) | 9 |
| 2.6 | MODIFICATIONS | 9 |
| 3 | TEST CONDITIONS AND RESULTS | 10 |
| 3.1 | OUTPUT POWER | 10 |
| 3.2 | OCCUPIED BANDWIDTH | 14 |
| 3.3 | BAND EDGE COMPLIANCE | 17 |
| 3.4 | SPURIOUS EMISSION | 19 |
| 3.5 | PEAK-TO-AVERAGE RATIO (PAR) | 29 |
| 3.6 | FREQUENCY STABILITY UNDER TEMPERATURE & VOLTAGE VARIATIONS | 33 |
| 4 | TEST SETUP PHOTOS OF THE EUT | 35 |
| 5 | EXTERNAL AND INTERNAL PHOTOS OF THE EUT | 35 |

1 **SUMMARY**

1.1 **TEST STANDARDS**

The tests were performed according to following standards:

[FCC Part 2:](#) FREQUENCY ALLOCATIONS AND RADIO TREATY MATTERS; GENERAL RULES AND REGULATIONS

[FCC Part 22 Subpart H:](#) PRIVATE LAND MOBILE RADIO SERVICES.

[FCC Part 24 Subpart E:](#) PUBLIC MOBILE SERVICES

[FCC Part 27:](#) MISCELLANEOUS WIRELESS COMMUNICATIONS SERVICES

[ANSI/TIA-603-E-2016:](#) Land Mobile FM or PM Communications Equipment Measurement and Performance Standards.

[ANSI C63.10-2013](#) Methods of Measurement of Radio-Noise Emissions from Low-Voltage Electrical and Electronic Equipment in the Range of 9 kHz to 40 GHz

[FCCKDB971168D01](#) Power Meas License Digital Systems

1.2 **Test Description**

| Test Item | Section in CFR 47 | Result |
|--|---|--------|
| RF Output Power | Part 2.1046 Part 22.913 (a)(2) Part 24.232 (c) Part 27.50(d) | Pass |
| Peak-to-Average Ratio | Part 24.232 (d) Part 27.50(d) | Pass |
| 99% & -26 dB Occupied Bandwidth | Part 2.1049 Part 22.917 Part 24.238 | Pass |
| Spurious Emissions at Antenna Terminal | Part 2.1051 Part 22.917 (a) Part 24.238 (a) Part 27.53(h) | Pass |
| Field Strength of Spurious Radiation | Part 2.1053 Part 22.917 (a) Part 24.238 (a) Part 27.53(h) | Pass |
| Out of band emission, Band Edge | Part 22.917 (a) Part 24.238 (a) Part 27.53(h) | Pass |
| Frequency stability | Part 2.1055 Part 22.355 Part 24.235 Part 27.54 | Pass |

1.3 **Address of the test laboratory**

Shenzhen CTA Testing Technology Co., Ltd.

Room 106, Building 1, Yibaolai Industrial Park, Qiaotou Community, Fuhai Street, Bao'an District, Shenzhen, China

The 3m-Semi anechoic test site fulfils CISPR 16-1-4 according to ANSI C63.4:2014 and CISPR 16-1-4:2010 SVSWR requirement for radiated emission above 1GHz.

1.4 **Test Facility**

The test facility is recognized, certified, or accredited by the following organizations:

FCC-Registration No.: 517856 Designation Number: CN1318

Shenzhen CTA Testing Technology Co., Ltd. has been listed on the US Federal Communications Commission list of test facilities recognized to perform electromagnetic emissions measurements.

Industry Canada Registration Number. Is: 27890 CAB identifier: CN0127

The Laboratory has been registered by Certification and Engineering Bureau of Industry Canada for radio equipment testing.

A2LA-Lab Cert. No.: 6534.01

Shenzhen CTA Testing Technology Co., Ltd. has been listed by American Association for Laboratory Accreditation to perform electromagnetic emission measurement.

The 3m-Semi anechoic test site fulfils CISPR 16-1-4 according to ANSI C63.10 and CISPR 16-1-4:2010.

1.5 Statement of the measurement uncertainty

The data and results referenced in this document are true and accurate. The reader is cautioned that there may be errors within the calibration limits of the equipment and facilities. The measurement uncertainty was calculated for all measurements listed in this test report acc. to TR-100028-01 "Electromagnetic compatibility and Radio spectrum Matters (ERM);Uncertainties in the measurement of mobile radio equipment characteristics; Part 1" and TR-100028-02 "Electromagnetic compatibility and Radio spectrum Matters (ERM);Uncertainties in the measurement of mobile radio equipment characteristics; Part 2 " and is documented in the Shenzhen CTA Testing Technology Co., Ltd. quality system acc. to DIN EN ISO/IEC 17025. Furthermore, component and process variability of devices similar to that tested may result in additional deviation. The manufacturer has the sole responsibility of continued compliance of the device. Hereafter the best measurement capability for Shenzhen CTA Testing Technology Co., Ltd. :

| Test | Range | Measurement Uncertainty | Notes |
|--|-------------|-------------------------|-------|
| Radiated Emission | 30~1000MHz | 4.06 dB | (1) |
| Radiated Emission | 1~18GHz | 5.14 dB | (1) |
| Radiated Emission | 18-40GHz | 5.38 dB | (1) |
| Conducted Disturbance | 0.15~30MHz | 2.14 dB | (1) |
| Output Peak power | 30MHz~18GHz | 0.55 dB | (1) |
| Power spectral density | / | 0.57 dB | (1) |
| Spectrum bandwidth | / | 1.1% | (1) |
| Radiated spurious emission (30MHz-1GHz) | 30~1000MHz | 4.10 dB | (1) |
| Radiated spurious emission (1GHz-18GHz) | 1~18GHz | 4.32 dB | (1) |
| Radiated spurious emission (18GHz-40GHz) | 18-40GHz | 5.54 dB | (1) |

- (1) This uncertainty represents an expanded uncertainty expressed at approximately the 95% confidence level using a coverage factor of k=2.

2 GENERAL INFORMATION

2.1 Environmental conditions

| | | |
|--------------------------------|---|--------------|
| Date of receipt of test sample | : | May 15, 2024 |
| Testing commenced on | : | May 15, 2024 |
| Testing concluded on | : | May 28, 2024 |

During the measurement the environmental conditions were within the listed ranges:

| | |
|---------------------|---------|
| Normal Temperature: | 25°C |
| Relative Humidity: | 55 % |
| Air Pressure: | 101 kPa |

2.2 General Description of EUT

| | |
|---|---|
| Product Name: | mobile phone |
| Model/Type reference: | F24 |
| Power supply: | DC 3.85V From battery and DC 5.0V From external circuit |
| Adapter information (Auxiliary test supplied by test Lab): | Model: EP-TA20CBC Input: AC 100-240V 50/60Hz Output: DC 5V 2A |
| Hardware version: | Q116_V1.0 |
| Software version: | KL_Q116_F1-F24_20240515 |
| Testing sample ID : | CTA231011002-1# (Engineer sample), CTA231011002-2# (Normal sample) |
| WCDMA | |
| Operation Band: | FDD Band II & Band IV & Band V |
| Power Class: | Power Class 3 |
| Modulation Type: | QPSK for WCDMA/HSUPA/HSDPA, 16QAM for HSPA+ |
| Release Version: | R8 |
| Antenna type: | PIFA antenna |
| Antenna gain: | FDD Band II: 1.37dBi FDD Band IV: 1.25dBi FDD Band V: 1.49dBi |

Note: For more details, refer to the user's manual of the EUT.

2.3 Description of Test Modes and Test Frequency

The EUT has been tested under typical operating condition. The CUM200 used to control the EUT staying in continuous transmitting and receiving mode for testing. Regards to the frequency band operation : the lowest, middle and highest frequency of channel were selected to perform the test, then shown on this report.

Test Frequency:

| FDD Band II | | FDD Band IV | | FDD Band V | |
|-------------|-----------------|-------------|-----------------|------------|-----------------|
| Channel | Frequency (MHz) | Channel | Frequency (MHz) | Channel | Frequency (MHz) |
| 9262 | 1852.4 | 1312 | 1712.4 | 4132 | 826.40 |
| 9400 | 1880.0 | 1413 | 1732.6 | 4182 | 836.60 |
| 9538 | 1907.6 | 1513 | 1752.6 | 4233 | 846.60 |

Test Modes:

The test mode(s) are selected according to relevant radio technology specifications.

| Test Mode | Test Modes Description |
|-----------|-------------------------------|
| Mode 1 | WCDMA system, QPSK modulation |
| Mode 2 | HSDPA system, QPSK modulation |
| Mode 3 | HSUPA system, QPSK modulation |

Note:

- As HSDPA and HSUPA with the same emission designator, test result recorded in this report at the worst case Mode 4 with RCM 12.2Kbps only after exploratory scan.

2.4 Equipments Used during the Test

| Test Equipment | Manufacturer | Model No. | Equipment No. | Calibration Date | Calibration Due Date |
|--------------------------------|------------------------|-------------|---------------|------------------|----------------------|
| LISN | R&S | ENV216 | CTA-308 | 2023/08/02 | 2024/08/01 |
| LISN | R&S | ENV216 | CTA-314 | 2023/08/02 | 2024/08/01 |
| EMI Test Receiver | R&S | ESPI | CTA-307 | 2023/08/02 | 2024/08/01 |
| EMI Test Receiver | R&S | ESCI | CTA-306 | 2023/08/02 | 2024/08/01 |
| Spectrum Analyzer | Agilent | N9020A | CTA-301 | 2023/08/02 | 2024/08/01 |
| Spectrum Analyzer | R&S | FSP | CTA-337 | 2023/08/02 | 2024/08/01 |
| Vector Signal generator | Agilent | N5182A | CTA-305 | 2023/08/02 | 2024/08/01 |
| Analog Signal Generator | R&S | SML03 | CTA-304 | 2023/08/02 | 2024/08/01 |
| Universal Radio Communication | CMW500 | R&S | CTA-302 | 2023/08/02 | 2024/08/01 |
| Temperature and humidity meter | Chigo | ZG-7020 | CTA-326 | 2023/08/02 | 2024/08/01 |
| Ultra-Broadband Antenna | Schwarzbeck | VULB9163 | CTA-310 | 2021/08/07 | 2024/08/06 |
| Horn Antenna | Schwarzbeck | BBHA 9120D | CTA-309 | 2021/08/07 | 2024/08/06 |
| Loop Antenna | Zhinan | ZN30900C | CTA-311 | 2021/08/07 | 2024/08/06 |
| Horn Antenna | Beijing Hangwei Dayang | OBH100400 | CTA-336 | 2021/08/07 | 2024/08/06 |
| Amplifier | Schwarzbeck | BBV 9745 | CTA-312 | 2023/08/02 | 2024/08/01 |
| Amplifier | Taiwan chengyi | EMC051845B | CTA-313 | 2023/08/02 | 2024/08/01 |
| Directional coupler | NARDA | 4226-10 | CTA-303 | 2023/08/02 | 2024/08/01 |
| High-Pass Filter | XingBo | XBLBQ-GTA18 | CTA-402 | 2023/08/02 | 2024/08/01 |
| High-Pass Filter | XingBo | XBLBQ-GTA27 | CTA-403 | 2023/08/02 | 2024/08/01 |
| Automated filter bank | Tonscend | JS0806-F | CTA-404 | 2023/08/02 | 2024/08/01 |
| Power Sensor | Agilent | U2021XA | CTA-405 | 2023/08/02 | 2024/08/01 |
| Amplifier | Schwarzbeck | BBV9719 | CTA-406 | 2023/08/02 | 2024/08/01 |

| Test Equipment | Manufacturer | Model No. | Version number | Calibration Date | Calibration Due Date |
|-------------------|--------------|-------------|----------------|------------------|----------------------|
| EMI Test Software | Tonscend | TS®JS32-RE | 5.0.0.2 | N/A | N/A |
| EMI Test Software | Tonscend | TS®JS32-CE | 5.0.0.1 | N/A | N/A |
| RF Test Software | Tonscend | TS®JS1120-3 | 3.1.65 | N/A | N/A |
| RF Test Software | Tonscend | TS®JS1120 | 3.1.46 | N/A | N/A |

2.5 Related Submittal(s) / Grant (s)

This submittal(s) (test report) is intended for FCC ID: 2BE8S-F24 filing to comply with of the FCC Part 22 and Part 24 and Part 27 Rules.

2.6 Modifications

No modifications were implemented to meet testing criteria.

3 TEST CONDITIONS AND RESULTS

3.1 Output Power

LIMIT

WCDMA Band V: 7W

WCDMA Band II: 2W

WCDMA Band IV: 1W

The Peak-to-Average Ratio (PAR) of the transmission may not exceed 13 Db.

TEST CONFIGURATION

Conducted Power Measurement

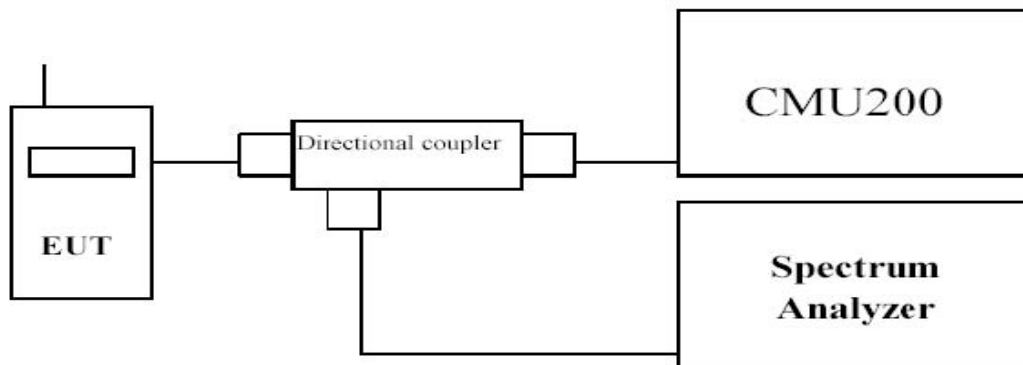

Radiated Power Measurement:

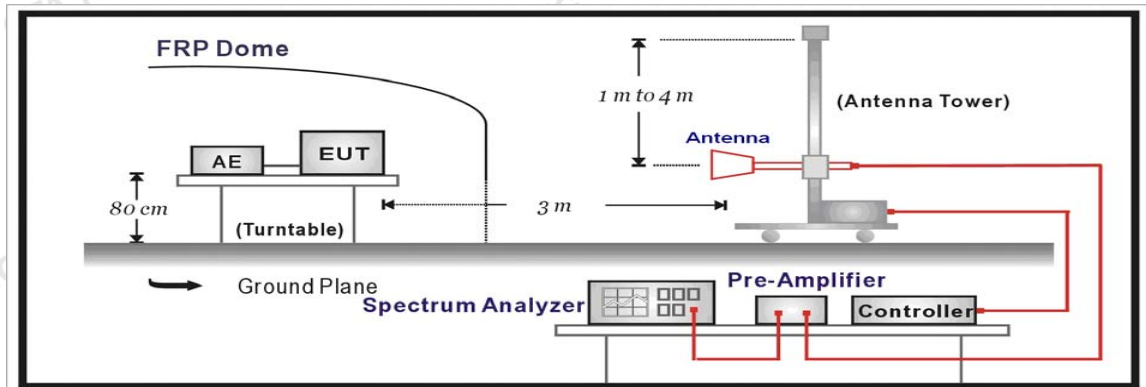

TEST PROCEDURE

The EUT was setup according to EIA/TIA 603C

Conducted Power Measurement:

- Place the EUT on a bench and set it in transmitting mode.
- Connect a low loss RF cable from the antenna port to a spectrum analyzer and CMU200 by a Directional Coupler.
- EUT Communicate with CMU200 then selects a channel for testing.
- Add a correction factor to the display of spectrum, and then test.

Radiated Power Measurement:

- The EUT shall be placed at the specified height on a support, and in the position closest to normal use as declared by provider.
- The test antenna shall be oriented initially for vertical polarization and shall be chosen to correspond to the frequency of the transmitter
- The output of the test antenna shall be connected to the measuring receiver.

- d) The transmitter shall be switched on and the measuring receiver shall be tuned to the frequency of the transmitter under test.
- e) The test antenna shall be raised and lowered through the specified range of height until a maximum signal level is detected by the measuring receiver.
- f) The transmitter shall then be rotated through 360° in the horizontal plane, until the maximum signal level is detected by the measuring receiver.
- g) The test antenna shall be raised and lowered again through the specified range of height until a maximum signal level is detected by the measuring receiver.
- h) The maximum signal level detected by the measuring receiver shall be noted.
- i) The transmitter shall be replaced by a substitution antenna.
- j) The substitution antenna shall be orientated for vertical polarization and the length of the substitution antenna shall be adjusted to correspond to the frequency of the transmitter.
- k) The substitution antenna shall be connected to a calibrated signal generator.
- l) If necessary, the input attenuator setting of the measuring receiver shall be adjusted in order to increase the sensitivity of the measuring receiver.
- m) The test antenna shall be raised and lowered through the specified range of height to ensure that the maximum signal is received.
- n) The input signal to the substitution antenna shall be adjusted to the level that produces a level detected by the measuring receiver, that is equal to the level noted while the transmitter radiated power was measured, corrected for the change of input attenuator setting of the measuring receiver.
- o) The measurement shall be repeated with the test antenna and the substitution antenna orientated for horizontal polarization.
- p) The measure of the effective radiated power is the larger of the two levels recorded at the input to the substitution antenna, corrected for gain of the substitution antenna if necessary.

TEST RESULTS**Conducted Measurement:**

| Item | Band | FDD Band II result (dBm) | | |
|-------|--------------|--------------------------|-------|-------|
| | | Test Channel | | |
| | | ARFCN | 9262 | 9400 |
| RMC | 12.2kbps RMC | 23.41 | 23.44 | 23.43 |
| HSDPA | Sub - Test 1 | 22.99 | 22.92 | 22.96 |
| | Sub - Test 2 | 22.84 | 22.89 | 22.81 |
| | Sub - Test 3 | 22.82 | 22.71 | 22.72 |
| | Sub - Test 4 | 22.82 | 22.79 | 22.81 |
| HSUPA | Sub - Test 1 | 22.78 | 22.88 | 22.78 |
| | Sub - Test 2 | 22.83 | 22.89 | 22.85 |
| | Sub - Test 3 | 22.75 | 22.80 | 22.78 |
| | Sub - Test 4 | 22.89 | 22.81 | 22.87 |
| | Sub - Test 5 | 22.80 | 22.77 | 22.84 |

| Item | Band | FDD Band IV result (dBm) | | |
|-------|--------------|--------------------------|-------|-------|
| | | Test Channel | | |
| | | ARFCN | 1312 | 1412 |
| RMC | 12.2kbps RMC | 23.44 | 23.59 | 23.51 |
| HSDPA | Sub - Test 1 | 22.96 | 22.96 | 22.91 |
| | Sub - Test 2 | 22.82 | 22.89 | 22.87 |
| | Sub - Test 3 | 22.71 | 22.83 | 22.73 |
| | Sub - Test 4 | 22.79 | 22.81 | 22.76 |
| HSUPA | Sub - Test 1 | 22.86 | 22.85 | 22.78 |
| | Sub - Test 2 | 22.89 | 22.85 | 22.85 |
| | Sub - Test 3 | 22.77 | 22.82 | 22.71 |
| | Sub - Test 4 | 22.85 | 22.85 | 22.89 |
| | Sub - Test 5 | 22.83 | 22.71 | 22.84 |

| Item | Band | FDD Band V result (dBm) | | |
|-------|--------------|-------------------------|-------|-------|
| | | Test Channel | | |
| | | ARFCN | 4132 | 4183 |
| RMC | 12.2kbps RMC | 23.52 | 23.41 | 23.53 |
| HSDPA | Sub - Test 1 | 22.99 | 22.95 | 22.92 |
| | Sub - Test 2 | 22.82 | 22.88 | 22.81 |
| | Sub - Test 3 | 22.84 | 22.71 | 22.76 |
| | Sub - Test 4 | 22.75 | 22.80 | 22.75 |
| HSUPA | Sub - Test 1 | 22.89 | 22.72 | 22.80 |
| | Sub - Test 2 | 22.80 | 22.88 | 22.84 |
| | Sub - Test 3 | 22.80 | 22.81 | 22.74 |
| | Sub - Test 4 | 22.83 | 22.89 | 22.84 |
| | Sub - Test 5 | 22.77 | 22.76 | 22.81 |

Radiated Measurement:

Note: 1. The field strength of radiation emission was measured in the following position: EUT stand-up position (Zaxis), lie-down position (X, Y axis). The data show in this report only with the worst case setup. After exploratory measurement the worst case of Z axis was reported.

Note: 2. We test the H direction and V direction and V direction is worse.

WCDMA BAND II

| Channel | P _{Mea} (dBm) | P _{cl} (dB) | G _a Antenna Gain(dB) | P _{Ag} (dB) | EIRP (dBm) | Limit (dBm) | Margin (dB) | Polarization |
|---------|---------------------------|-------------------------|---------------------------------------|-------------------------|---------------|----------------|----------------|--------------|
| 9262 | -17.97 | 3.41 | 10.24 | 33.6 | 22.46 | 33.01 | -10.55 | V |
| 9400 | -17.28 | 3.49 | 10.24 | 33.6 | 23.07 | 33.01 | -9.94 | V |
| 9538 | -16.35 | 3.55 | 10.23 | 33.6 | 23.93 | 33.01 | -9.08 | V |

WCDMA BAND IV

| Channel | P _{Mea} (dBm) | P _{cl} (dB) | G _a Antenna Gain(dB) | P _{Ag} (dB) | EIRP (dBm) | Limit (dBm) | Margin (dB) | Polarization |
|---------|---------------------------|-------------------------|---------------------------------------|-------------------------|---------------|----------------|----------------|--------------|
| 1312 | -16.86 | 3.15 | 9.58 | 33.6 | 23.17 | 30.00 | -6.83 | V |
| 1413 | -18.00 | 3.17 | 9.62 | 33.6 | 22.05 | 30.00 | -7.95 | V |
| 1513 | -16.97 | 3.26 | 9.71 | 33.6 | 23.08 | 30.00 | -6.92 | V |

WCDMA BAND V

| Channel | P _{Mea} (dBm) | P _{cl} (dB) | G _a Antenna Gain(dB) | Correction (dB) | P _{Ag} (dB) | ERP (dBm) | Limit (dBm) | Margin (dB) | Polarization |
|---------|---------------------------|-------------------------|---------------------------------------|--------------------|-------------------------|--------------|----------------|----------------|--------------|
| 4132 | -17.29 | 2.42 | 8.45 | 36.82 | 2.15 | 23.41 | 38.45 | -15.04 | V |
| 4183 | -17.03 | 2.46 | 8.45 | 36.82 | 2.15 | 23.63 | 38.45 | -14.82 | V |
| 4233 | -16.59 | 2.53 | 8.36 | 36.82 | 2.15 | 23.91 | 38.45 | -14.54 | V |

Remark:

- $EIRP = P_{Mea}(dBm) - P_{cl}(dB) + P_{Ag}(dB) + G_a(dBi)$
- $ERP = EIRP - 2.15dB$ as EIRP by subtracting the gain of the dipole.

3.2 Occupied Bandwidth

LIMIT

N/A

TEST CONFIGURATION

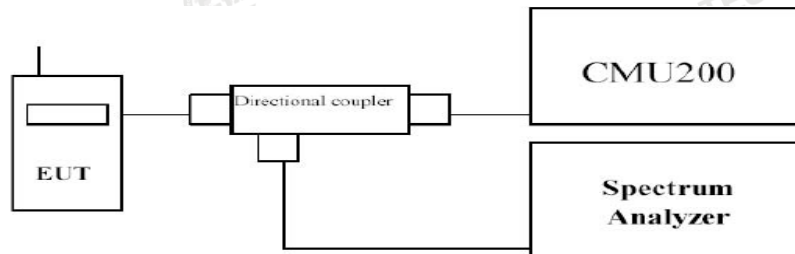

TEST PROCEDURE

1. The EUT's output RF connector was connected with a short cable to the spectrum analyzer
2. RBW was set to about 1% of emission BW, VBW \geq 3 times RBW.
3. -26dBc display line was placed on the screen (or 99% bandwidth), the occupied bandwidth is the delta frequency between the two points where the display line intersects the signal trace.

TEST RESULTS

| EUT Mode | Channel | Frequency (MHz) | 99% Occupy bandwidth (KHz) | -26dB bandwidth (KHz) |
|----------------------|---------|-----------------|----------------------------|-----------------------|
| WCDMA Band II (QPSK) | 9262 | 1852.4 | 4.1730 | 4.702 |
| | 9400 | 1880.0 | 4.1658 | 4.707 |
| | 9538 | 1907.6 | 4.1656 | 4.706 |
| WCDMA Band VI (QPSK) | 1312 | 1712.4 | 4.1673 | 4.710 |
| | 1413 | 1732.6 | 4.1582 | 4.704 |
| | 1513 | 1752.6 | 4.1863 | 4.733 |
| WCDMA Band V (QPSK) | 4132 | 826.4 | 4.1758 | 4.713 |
| | 4183 | 836.6 | 4.1638 | 4.708 |
| | 4233 | 846.6 | 4.1539 | 4.695 |

Test plots as follow:

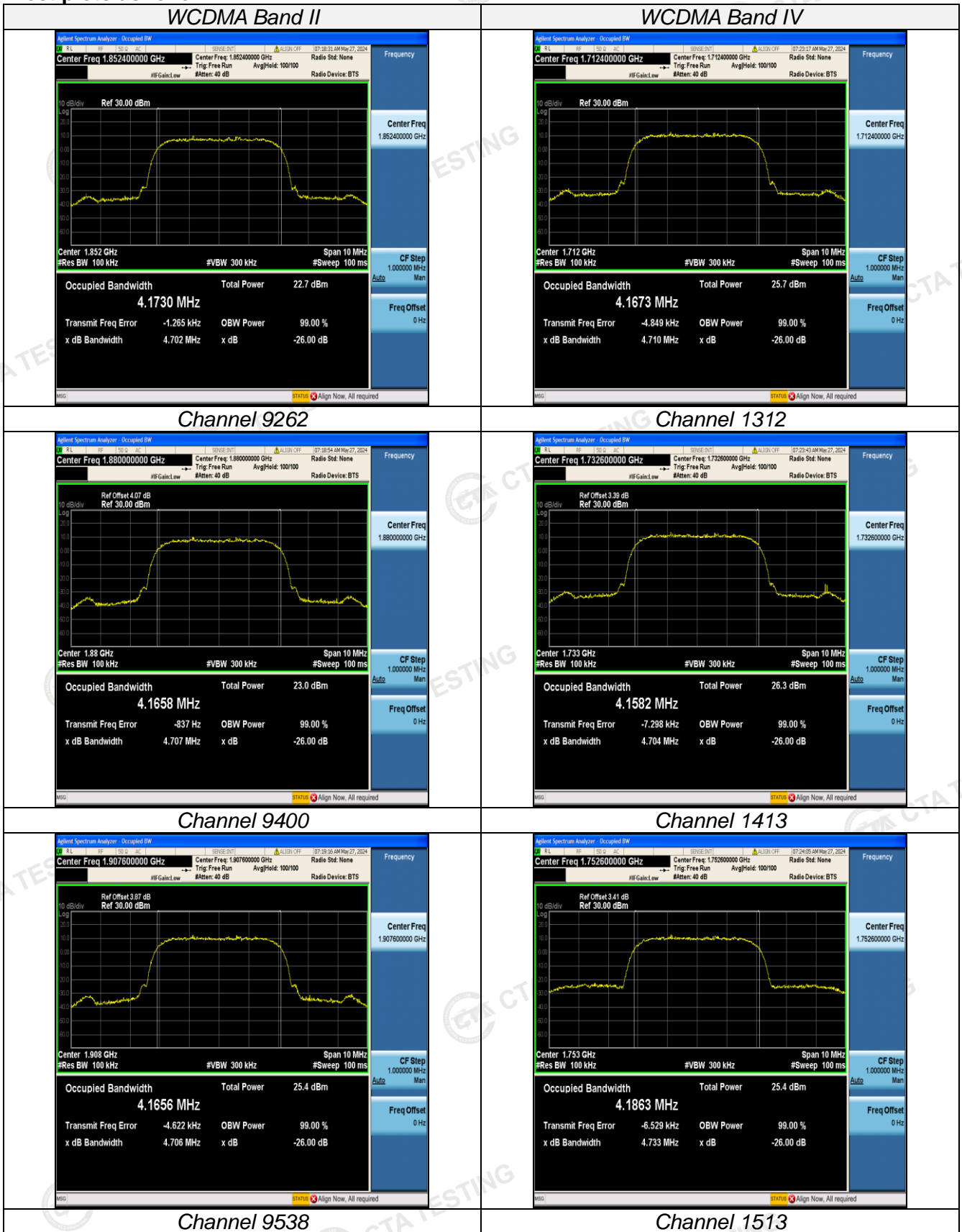

WCDMA Band V

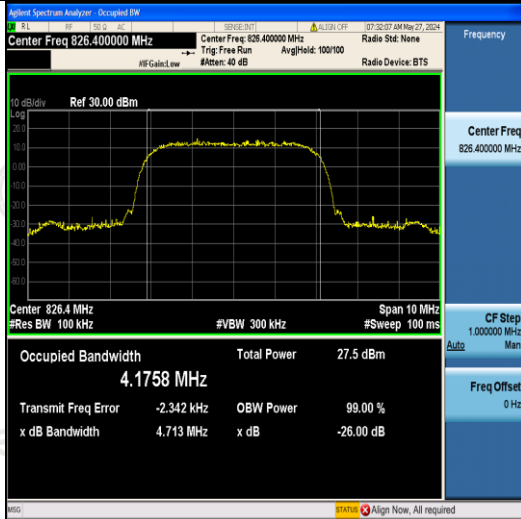

Channel 4132

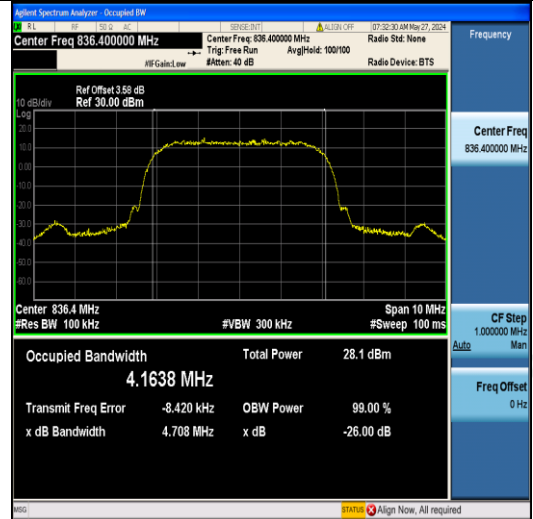

Channel 4182

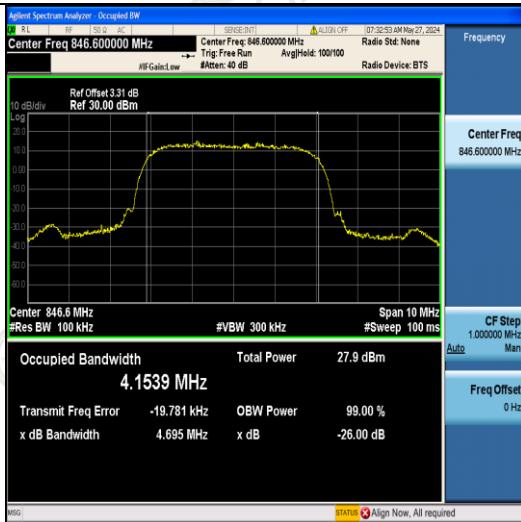

Channel 4233

3.3 Band Edge compliance

LIMIT

The power of any emission outside of the authorized operating frequency ranges must be attenuated below the transmitting power (P) by a factor of at least $43 + 10\log(P)$ dB.

TEST CONFIGURATION

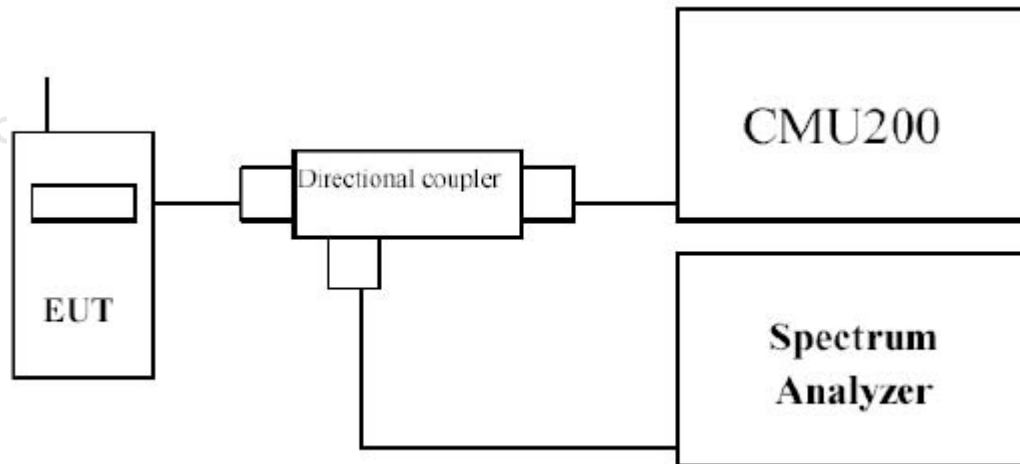

TEST PROCEDURE

In the 1MHz bands immediately outside and adjacent to the frequency block a resolution bandwidth of at least one percent of the emission bandwidth of the fundamental emission of the transmitter may be employed to measure the out of band Emissions.

TEST RESULTS

WCDMA Band II

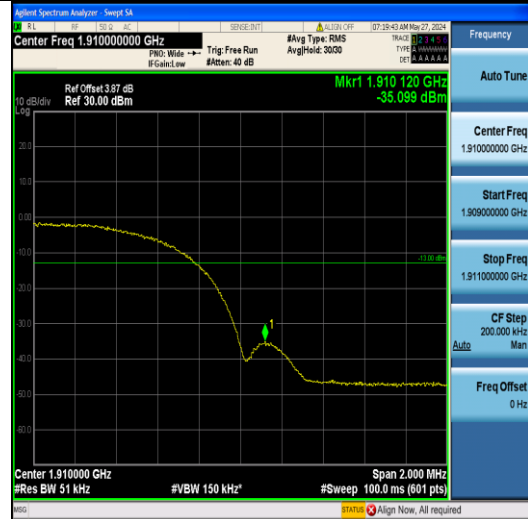

WCDMA Band IV

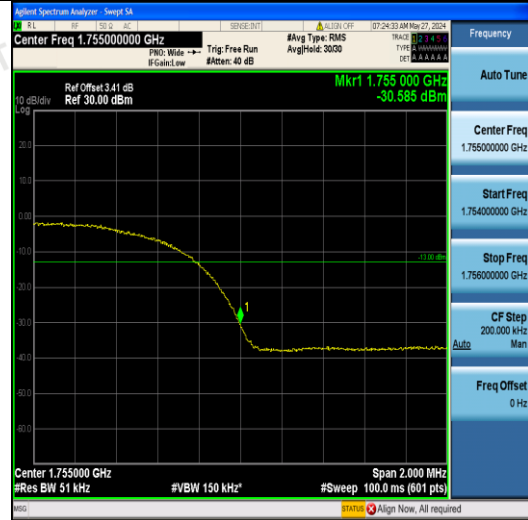
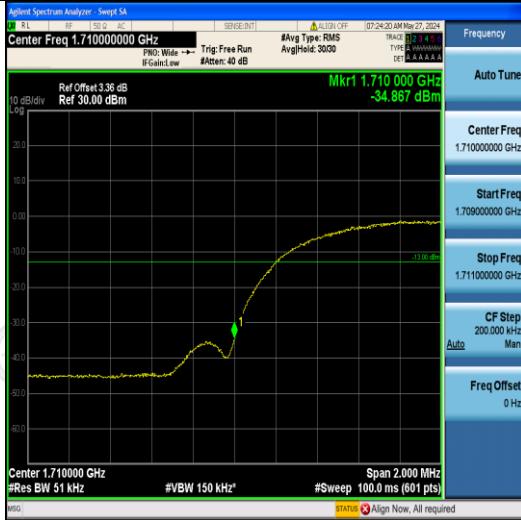

WCDMA Band V

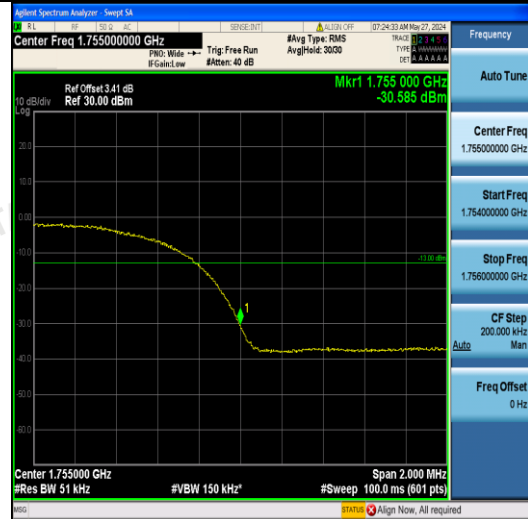
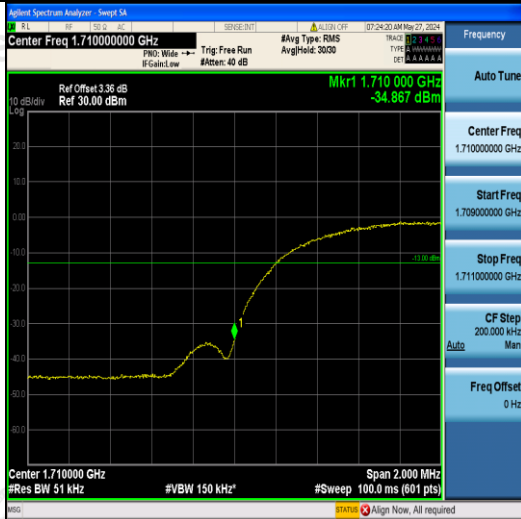

3.4 Spurious Emission

LIMIT

The power of any emission outside of the authorized operating frequency ranges must be attenuated below the transmitting power (P) by a factor of at least $43 + 10\log(P)$ dB.

TEST CONFIGURATION

Conducted Spurious Measurement:

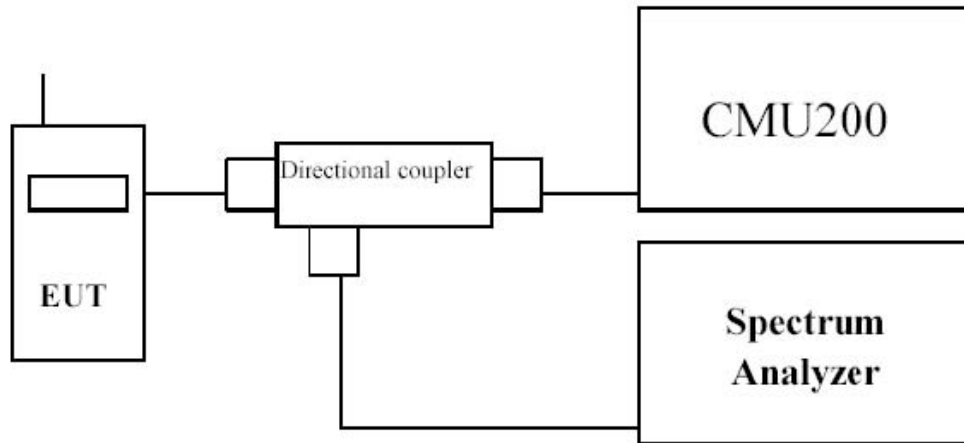

Radiated Spurious Measurement:

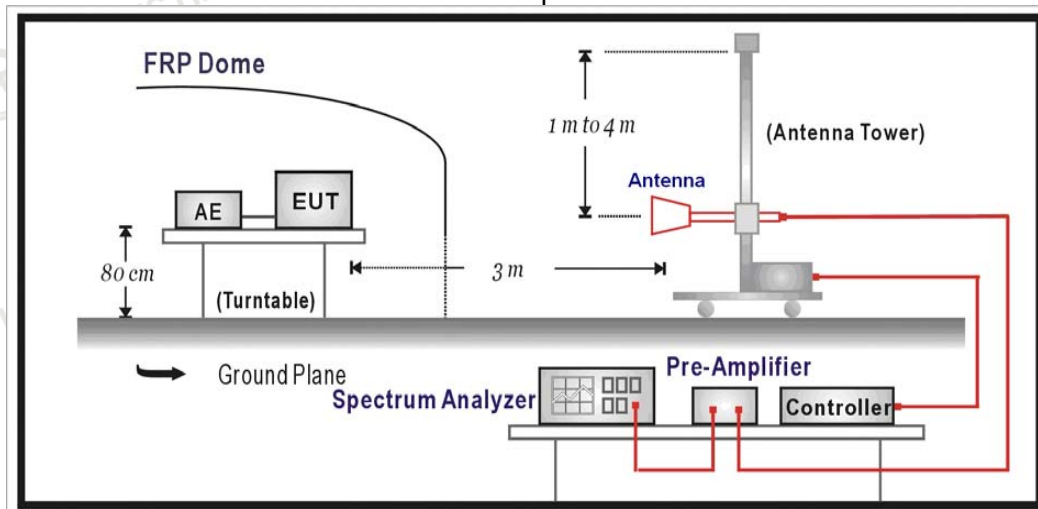

TEST PROCEDURE

The EUT was setup according to EIA/TIA 603C

Conducted Spurious Measurement:

- Place the EUT on a bench and set it in transmitting mode.
- Connect a low loss RF cable from the antenna port to a spectrum analyzer and CMU200 by a Directional Couple.
- EUT Communicate with CMU200 then selects a channel for testing.
- Add a correction factor to the display of spectrum, and then test.
- The resolution bandwidth of the spectrum analyzer was set at 1MHz for Part 22 and 1MHz for Part 24, sufficient scans were taken to show the out of band Emission if any up to 10th harmonic.

Radiated Spurious Measurement:

- a) The EUT shall be placed at the specified height on a support, and in the position closest to normal use as declared by provider.
- b) The test antenna shall be oriented initially for vertical polarization and shall be chosen to correspond to the frequency of the transmitter
- c) The output of the test antenna shall be connected to the measuring receiver.
- d) The transmitter shall be switched on and the measuring receiver shall be tuned to the frequency of the transmitter under test.
- e) The test antenna shall be raised and lowered through the specified range of height until a maximum signal level is detected by the measuring receiver.
- f) The transmitter shall then be rotated through 360° in the horizontal plane, until the maximum signal level is detected by the measuring receiver.
- g) The test antenna shall be raised and lowered again through the specified range of height until a maximum signal level is detected by the measuring receiver.
- h) The maximum signal level detected by the measuring receiver shall be noted.
- i) The transmitter shall be replaced by a substitution antenna.
- j) The substitution antenna shall be orientated for vertical polarization and the length of the substitution antenna shall be adjusted to correspond to the frequency of the transmitter.
- k) The substitution antenna shall be connected to a calibrated signal generator.
- l) If necessary, the input attenuator setting of the measuring receiver shall be adjusted in order to increase the sensitivity of the measuring receiver.
- m) The test antenna shall be raised and lowered through the specified range of height to ensure that the maximum signal is received.
- n) The input signal to the substitution antenna shall be adjusted to the level that produces a level detected by the measuring receiver, that is equal to the level noted while the transmitter radiated power was measured, corrected for the change of input attenuator setting of the measuring receiver.
- o) The measurement shall be repeated with the test antenna and the substitution antenna orientated for horizontal polarization.
- p) The measure of the effective radiated power is the larger of the two levels recorded at the input to the substitution antenna, corrected for gain of the substitution antenna if necessary.
- q) The resolution bandwidth of the spectrum analyzer was set at 100 kHz for Part 22 and 1MHz for Part 24. The frequency range was checked up to 10th harmonic.

TEST RESULTS

Conducted Measurement:

WCDMA Band II

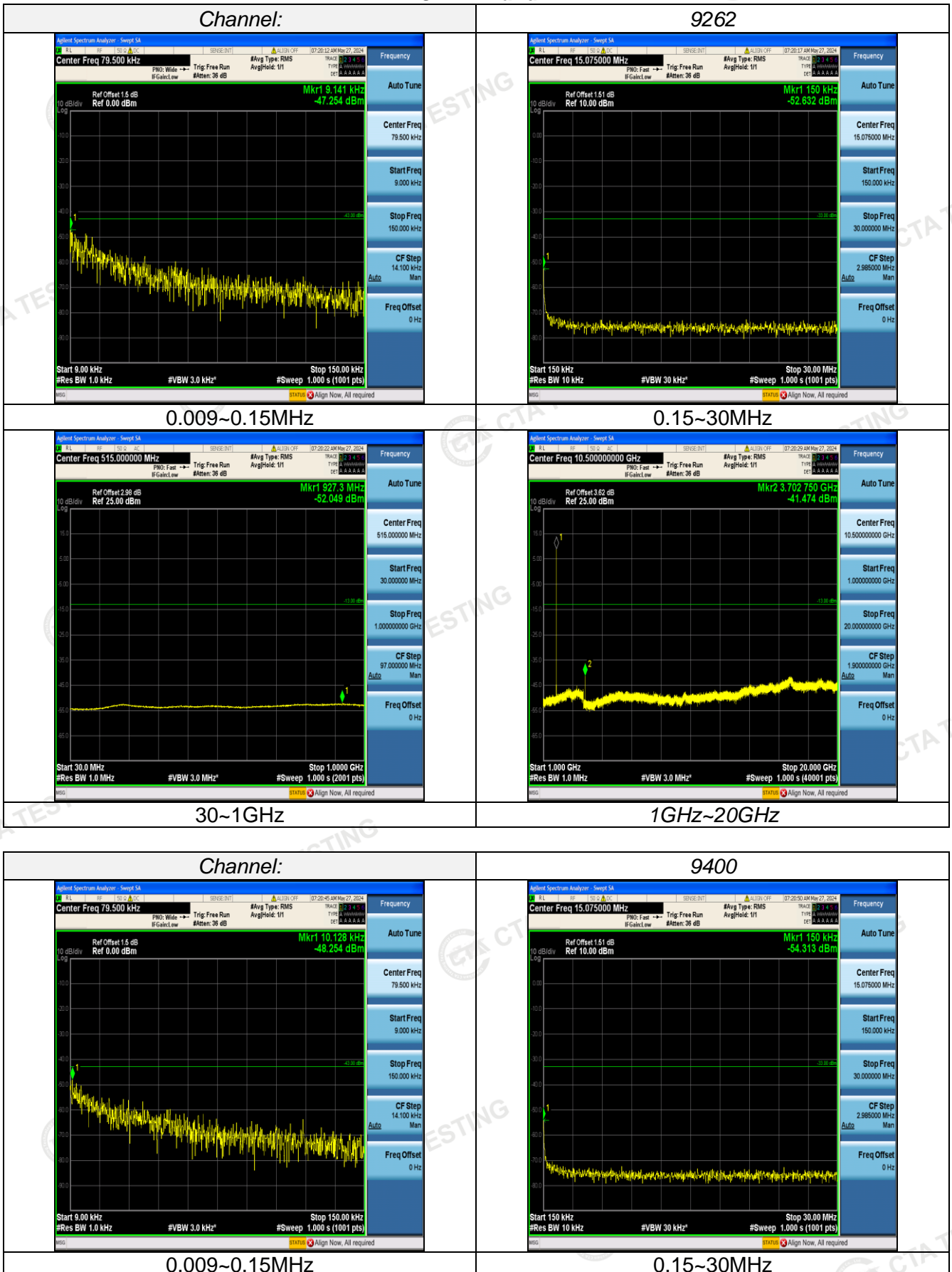

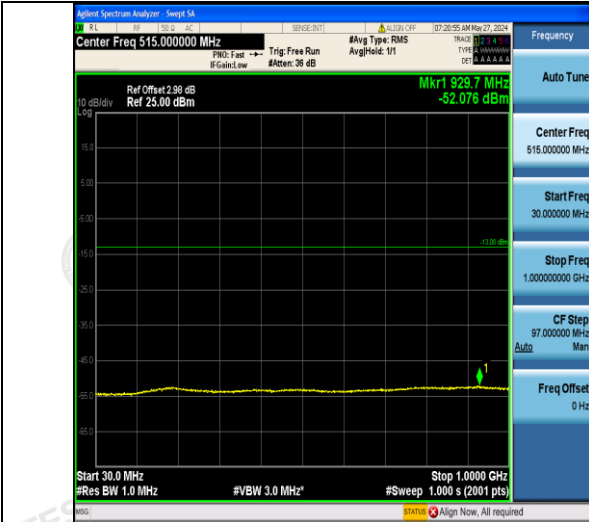

30~1GHz
Channel:



1GHz~20GHz
9538

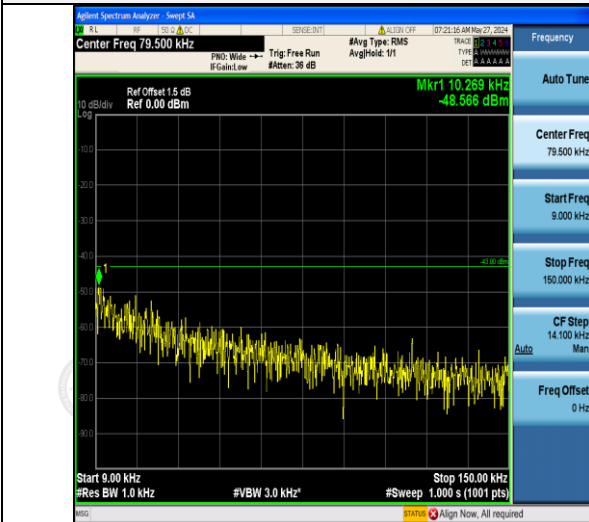

0.009~0.15MHz

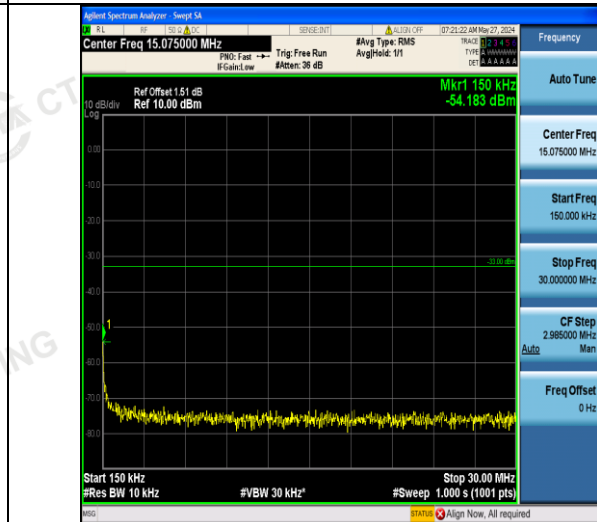

0.15~30MHz



30~1GHz



1GHz~20GHz

WCDMA Band IV

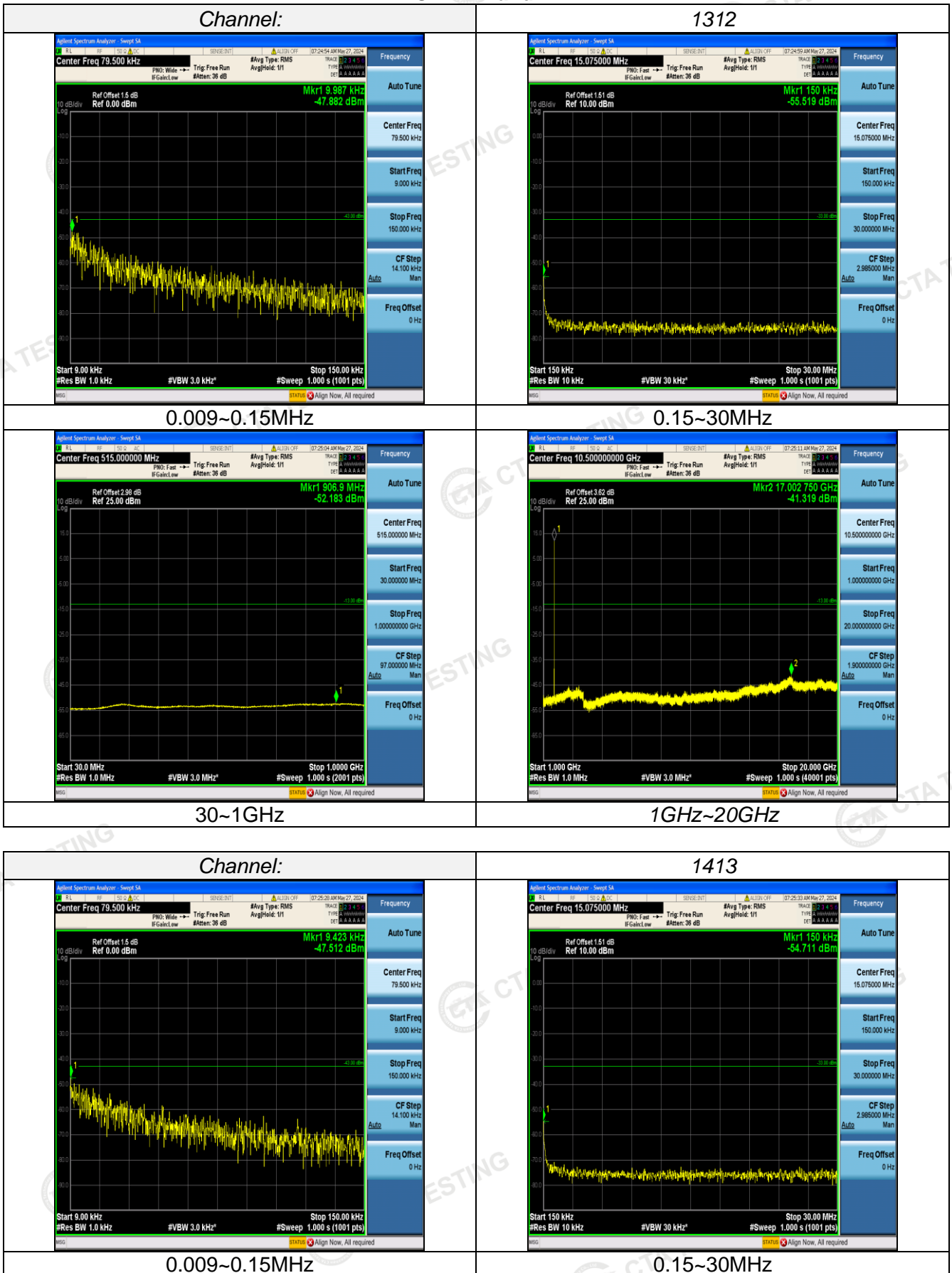

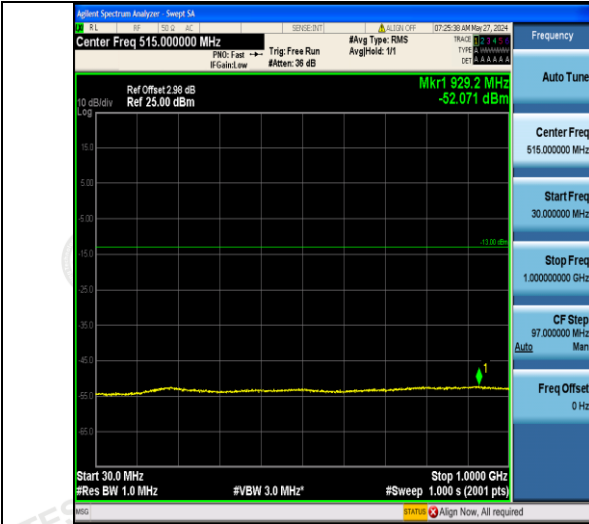

30~1GHz
Channel:



1GHz~20GHz
1513

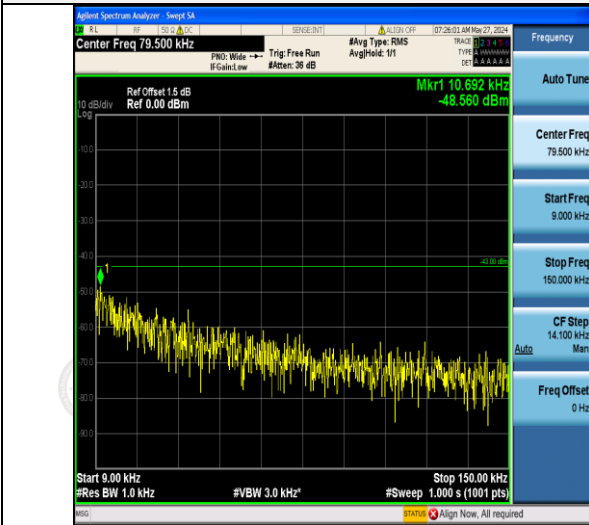

0.009~0.15MHz

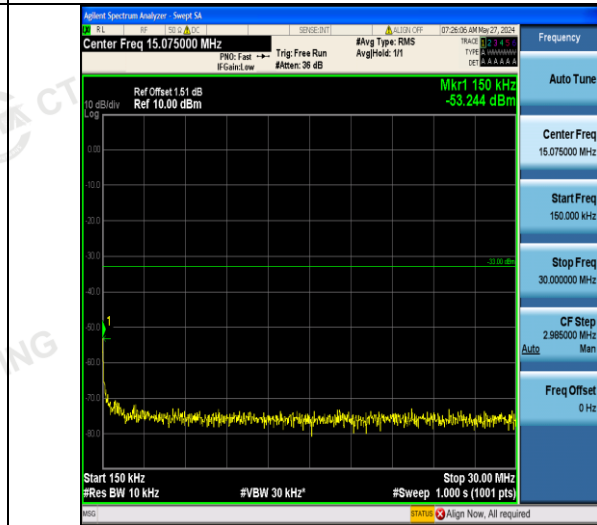

0.15~30MHz



30~1GHz



1GHz~20GHz

WCDMA Band V

Channel:

4132

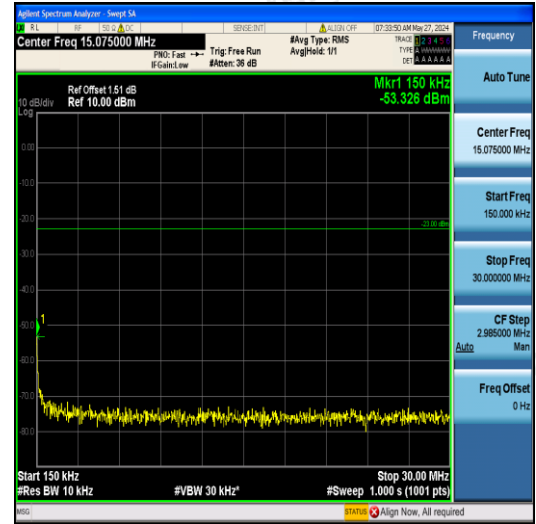
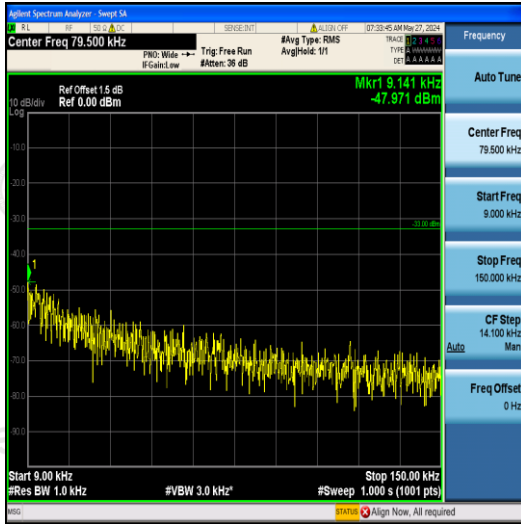

0.009~0.15MHz

0.15~30MHz

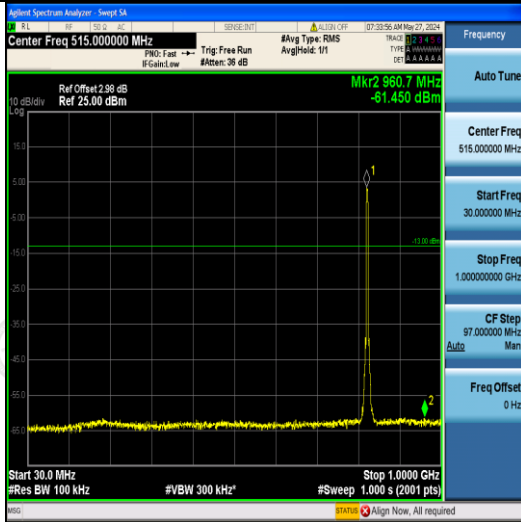

30MHz~1GHz

1GHz~10GHz

Channel:

4183

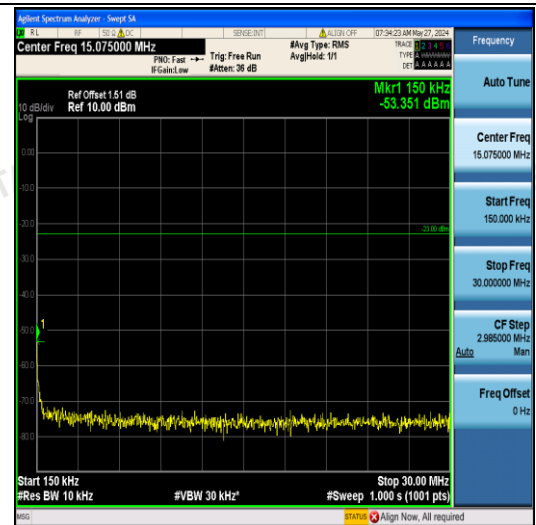
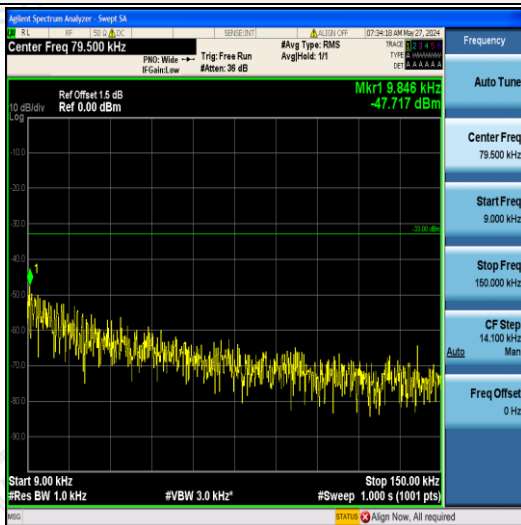

0.009~0.15MHz

0.15~30MHz

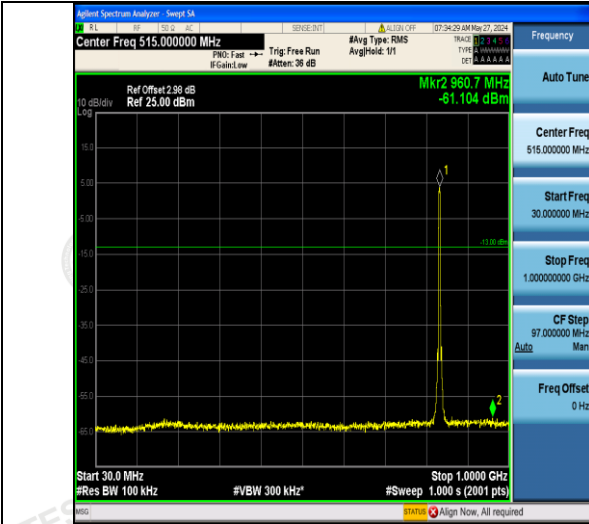

30MHz~1GHz
Channel:



1GHz~10GHz
4233



0.009~0.15MHz

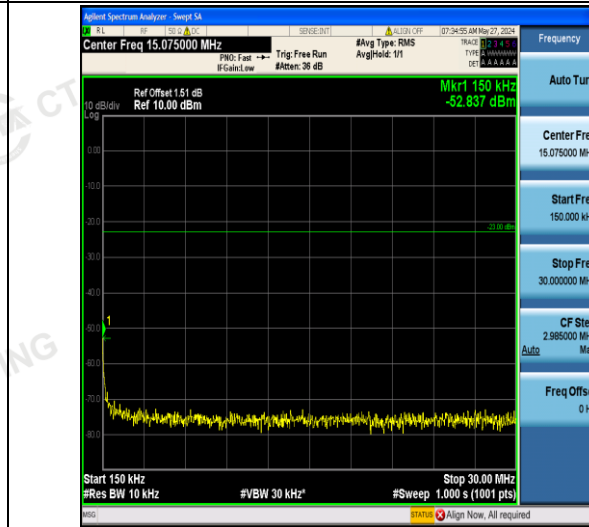

0.15~30MHz

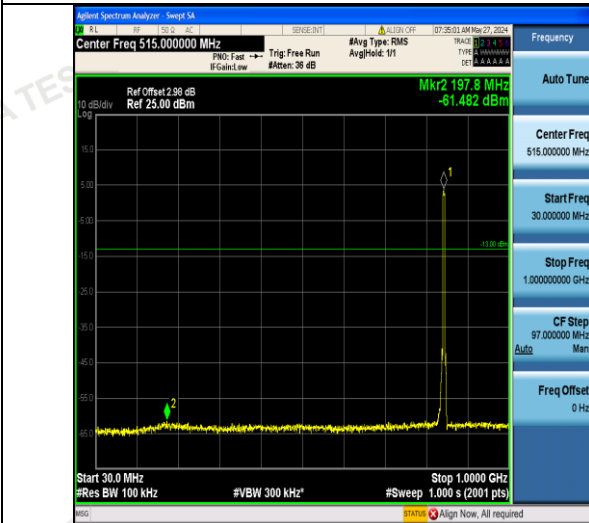

30MHz~1GHz



1GHz~10GHz

Radiated Measurement:

WCDMA Band II

| Channel | Frequency (MHz) | P _{Mea} (dBm) | P _{cl} (dB) | Distance | G _a Antenna Gain(dB) | Peak EIRP (dBm) | Limit (dBm) | Margin (dB) | Polarization |
|---------|-----------------|------------------------|----------------------|----------|---------------------------------|-----------------|-------------|-------------|--------------|
| 9262 | 3704.80 | -44.57 | 4.27 | 3.00 | 12.34 | -36.50 | -13.00 | -23.50 | H |
| | 5557.20 | -48.86 | 4.99 | 3.00 | 13.52 | -40.33 | -13.00 | -27.33 | H |
| | 3704.80 | -45.70 | 4.27 | 3.00 | 12.34 | -37.63 | -13.00 | -24.63 | V |
| | 5557.20 | -55.25 | 4.99 | 3.00 | 13.52 | -46.72 | -13.00 | -33.72 | V |
| 9400 | 3760.00 | -41.20 | 4.38 | 3.00 | 12.34 | -33.24 | -13.00 | -20.24 | H |
| | 5640.00 | -55.99 | 5.01 | 3.00 | 13.58 | -47.42 | -13.00 | -34.42 | H |
| | 3760.00 | -44.91 | 4.38 | 3.00 | 12.34 | -36.95 | -13.00 | -23.95 | V |
| | 5640.00 | -46.61 | 5.01 | 3.00 | 13.58 | -38.04 | -13.00 | -25.04 | V |
| 9538 | 3815.20 | -42.66 | 4.47 | 3.00 | 12.45 | -34.68 | -13.00 | -21.68 | H |
| | 5722.80 | -52.68 | 5.23 | 3.00 | 13.66 | -44.25 | -13.00 | -31.25 | H |
| | 3815.20 | -40.31 | 4.47 | 3.00 | 12.45 | -32.33 | -13.00 | -19.33 | V |
| | 5722.80 | -48.33 | 5.23 | 3.00 | 13.66 | -39.90 | -13.00 | -26.90 | V |

WCDMA Band IV

| Channel | Frequency (MHz) | P _{Mea} (dBm) | P _{cl} (dB) | Distance | G _a Antenna Gain(dB) | Peak EIRP (dBm) | Limit (dBm) | Margin (dB) | Polarization |
|---------|-----------------|------------------------|----------------------|----------|---------------------------------|-----------------|-------------|-------------|--------------|
| 1312 | 3424.80 | -41.46 | 3.98 | 3.00 | 10.98 | -34.46 | -13.00 | -21.46 | H |
| | 5137.20 | -50.88 | 4.11 | 3.00 | 11.47 | -43.52 | -13.00 | -30.52 | H |
| | 3424.80 | -40.15 | 3.98 | 3.00 | 10.98 | -33.15 | -13.00 | -20.15 | V |
| | 5137.20 | -53.94 | 4.11 | 3.00 | 11.47 | -46.58 | -13.00 | -33.58 | V |
| 1413 | 3465.20 | -40.47 | 4.01 | 3.00 | 11.25 | -33.23 | -13.00 | -20.23 | H |
| | 5197.80 | -54.30 | 4.15 | 3.00 | 11.58 | -46.87 | -13.00 | -33.87 | H |
| | 3465.20 | -43.39 | 4.01 | 3.00 | 11.25 | -36.15 | -13.00 | -23.15 | V |
| | 5197.80 | -46.33 | 4.15 | 3.00 | 11.58 | -38.90 | -13.00 | -25.90 | V |
| 1513 | 3505.20 | -40.62 | 4.07 | 3.00 | 11.33 | -33.36 | -13.00 | -20.36 | H |
| | 5275.80 | -55.25 | 4.21 | 3.00 | 11.67 | -47.79 | -13.00 | -34.79 | H |
| | 3505.20 | -44.44 | 4.07 | 3.00 | 11.33 | -37.18 | -13.00 | -24.18 | V |
| | 5275.80 | -47.08 | 4.21 | 3.00 | 11.67 | -39.62 | -13.00 | -26.62 | V |

WCDMA Band V

| Channel | Frequency (MHz) | P _{Mea} (dBm) | P _{cl} (dB) | Distance | G _a Antenna Gain (dB) | Peak EIRP (dBm) | Limit (dBm) | Margin (dB) | Polarization |
|---------|-----------------|------------------------|----------------------|----------|----------------------------------|-----------------|-------------|-------------|--------------|
| 9262 | 1652.80 | -43.19 | 3.02 | 3.00 | 9.58 | -36.63 | -13.00 | -23.63 | H |
| | 2479.20 | -53.50 | 3.51 | 3.00 | 10.72 | -46.29 | -13.00 | -33.29 | H |
| | 1652.80 | -45.47 | 3.02 | 3.00 | 9.68 | -38.81 | -13.00 | -25.81 | V |
| | 2479.20 | -54.80 | 3.51 | 3.00 | 10.72 | -47.59 | -13.00 | -34.59 | V |
| 9400 | 1673.20 | -44.40 | 3.14 | 3.00 | 9.61 | -37.93 | -13.00 | -24.93 | H |
| | 2509.80 | -55.40 | 3.59 | 3.00 | 10.77 | -48.22 | -13.00 | -35.22 | H |
| | 1673.20 | -43.85 | 3.14 | 3.00 | 9.61 | -37.38 | -13.00 | -24.38 | V |
| | 2509.80 | -54.39 | 3.59 | 3.00 | 10.77 | -47.21 | -13.00 | -34.21 | V |
| 9538 | 1693.20 | -45.35 | 3.24 | 3.00 | 9.77 | -38.82 | -13.00 | -25.82 | H |
| | 2539.80 | -50.76 | 3.65 | 3.00 | 10.89 | -43.52 | -13.00 | -30.52 | H |
| | 1693.20 | -45.25 | 3.24 | 3.00 | 9.77 | -38.72 | -13.00 | -25.72 | V |
| | 2539.80 | -48.82 | 3.65 | 3.00 | 10.89 | -41.58 | -13.00 | -28.58 | V |

Remark:

1. $EIRP = P_{Mea}(dBm) - P_{cl}(dB) + G_a(dBi)$
2. We were not recorded other points as values lower than limits.
3. $Margin = EIRP - Limit$

3.5 Peak-to-Average Ratio (PAR)

LIMIT

The Peak-to-Average Ratio (PAR) of the transmission may not exceed 13 dB.

TEST CONFIGURATION

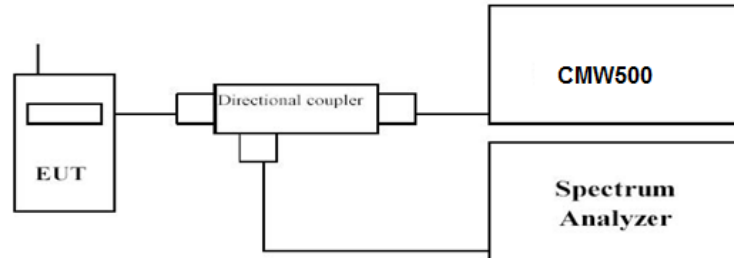

TEST PROCEDURE

1. Refer to instrument's analyzer instruction manual for details on how to use the power statistics/CCDF function;
2. Set resolution/measurement bandwidth \geq signal's occupied bandwidth;
3. Set the number of counts to a value that stabilizes the measured CCDF curve;
4. Set the measurement interval as follows: 1). for continuous transmissions, set to 1 ms, 2). for burst transmissions, employ an external trigger that is synchronized with the EUT burst timing sequence, or use the internal burst trigger with a trigger level that allows the burst to stabilize and set the measurement interval to a time that is less than or equal to the burst duration.
5. Record the maximum PAPR level associated with a probability of 0.1%.

TEST RESULTS

| Test mode | Channel | Frequency (MHz) | PAPR Value (dB) | Limits (dB) | Verdict |
|---------------|---------|-----------------|-----------------|-------------|---------|
| WCDMA Band II | 9262 | 1852.4 | 2.87 | 13.0 | Pass |
| | 9400 | 1880.0 | 2.95 | 13.0 | Pass |
| | 9538 | 1907.6 | 2.98 | 13.0 | Pass |
| WCDMA Band IV | 1312 | 1712.4 | 2.88 | 13.0 | Pass |
| | 1413 | 1732.6 | 2.85 | 13.0 | Pass |
| | 1513 | 1752.6 | 2.51 | 13.0 | Pass |
| WCDMA Band V | 4132 | 826.4 | 2.84 | 13.0 | Pass |
| | 4183 | 836.6 | 2.98 | 13.0 | Pass |
| | 4233 | 846.6 | 3.03 | 13.0 | Pass |

Band2-9262

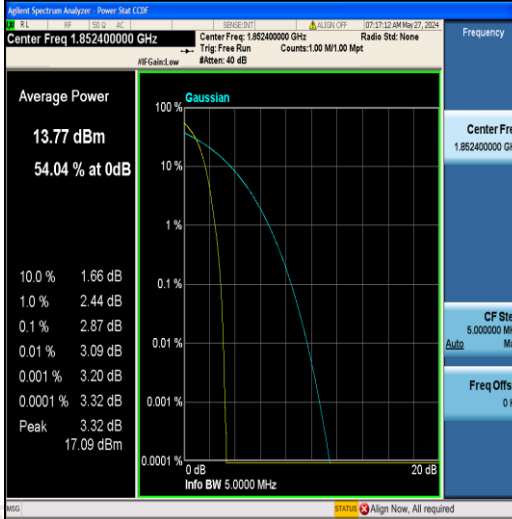

Band2-9400

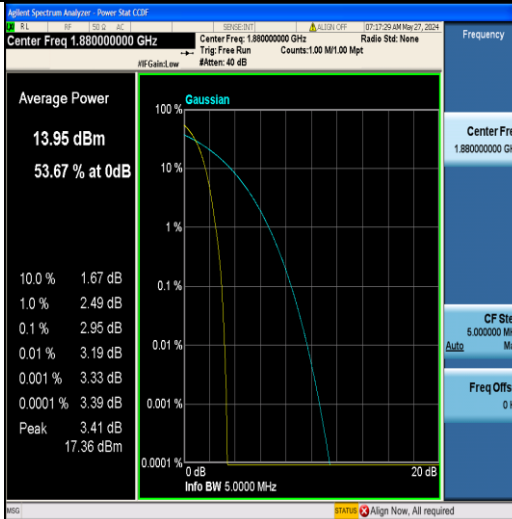

Band2-9538

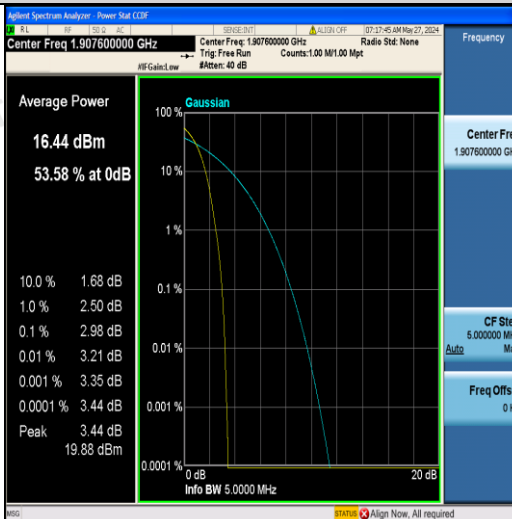

Band4-1312

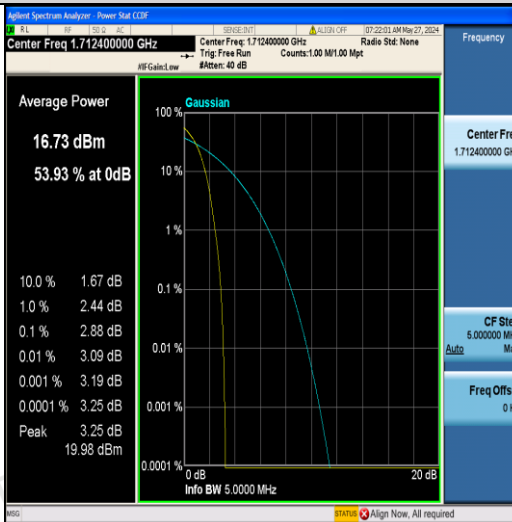

Band4-1413

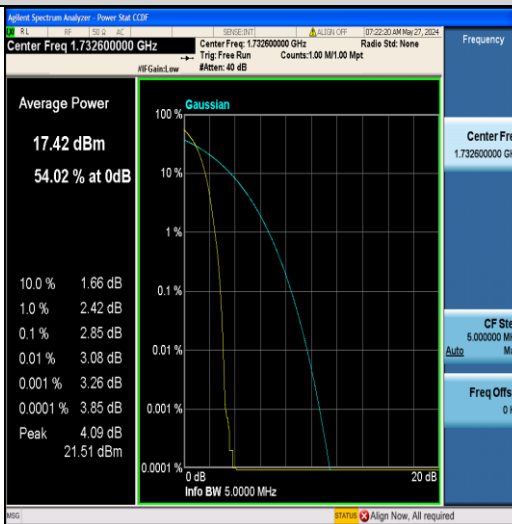

Band4-1513

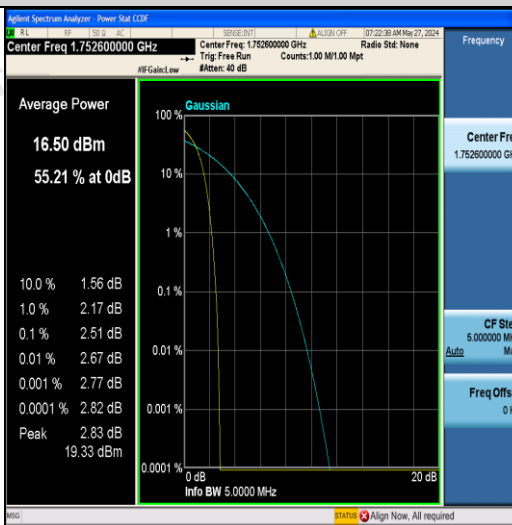

Band5-4132

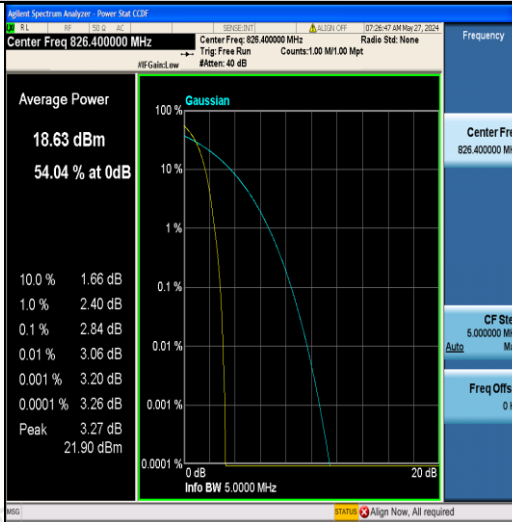

Band5-4183

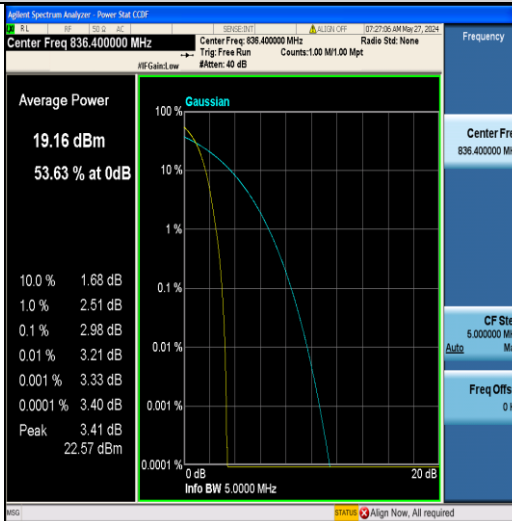

Band5-4233

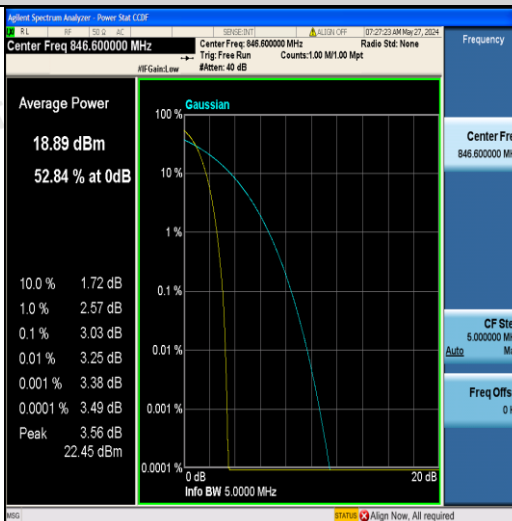

3.6 Frequency Stability under Temperature & Voltage Variations

LIMIT

Cellular Band: ± 2.5 ppm PCS Band: Within the authorized frequency block

TEST CONFIGURATION

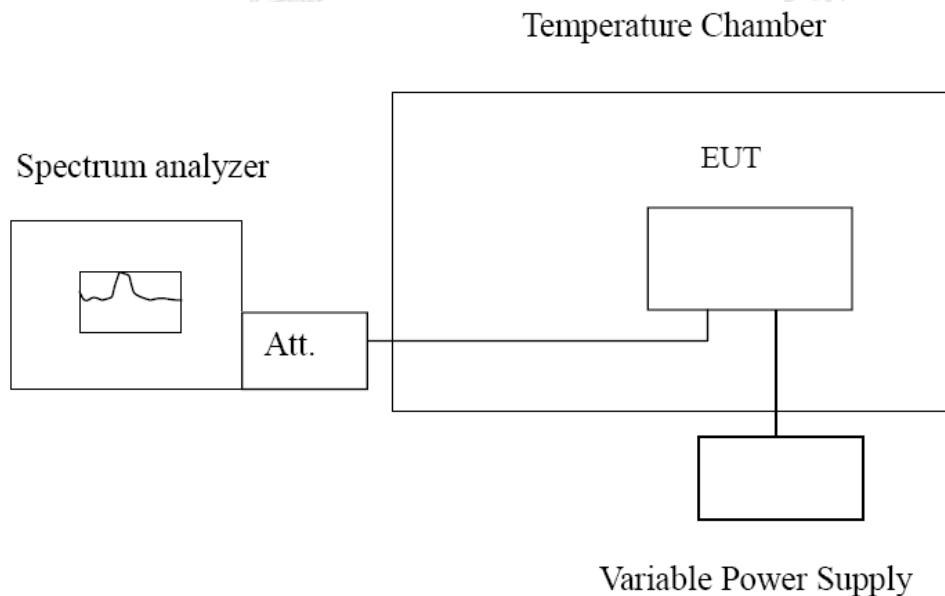

TEST PROCEDURE

The EUT was setup according to EIA/TIA 603C

Frequency Stability under Temperature Variations:

The equipment under test was connected to an external AC or DC power supply and input rated voltage. RF output was connected to a frequency counter or spectrum analyzer via feed through attenuators. The EUT was placed inside the temperature chamber. Set the spectrum analyzer RBW low enough to obtain the desired frequency resolution and measure EUT 20°C operating frequency as reference frequency. Turn EUT off and set the chamber temperature to -30°C. After the temperature stabilized for approximately 30 minutes recorded the frequency. Repeat step measure with 10°C increased per stage until the highest temperature of +50°C reached.

Frequency Stability under Voltage Variations:

Set chamber temperature to 20°C. Use a variable AC power supply / DC power source to power the EUT and set the voltage to rated voltage. Set the spectrum analyzer RBW low enough to obtain the desired frequency resolution and recorded the frequency.

Reduce the input voltage to specify extreme voltage variation ($\pm 15\%$) and endpoint, record the maximum frequency change.

TEST RESULTS

| Reference Frequency: WCDMA Band II Middle channel=9400 channel=1880MHz | | | | | |
|--|------------------|-----------------|--------|-------------|--------|
| Voltage (V) | Temperature (°C) | Frequency error | | Limit (ppm) | Result |
| | | Hz | ppm | | |
| 3.85 | -30 | 7 | 0.004 | ±2.5 | Pass |
| | -20 | -2 | -0.001 | | |
| | -10 | -1 | -0.001 | | |
| | 0 | 8 | 0.004 | | |
| | 10 | 5 | 0.003 | | |
| | 20 | -15 | -0.008 | | |
| | 30 | -15 | -0.008 | | |
| | 40 | 7 | 0.004 | | |
| 50 | 20 | 0.011 | | | |
| 4.20 | 25 | -20 | -0.011 | | |
| End point 3.40 | 25 | 20 | 0.011 | | |

| Reference Frequency: WCDMA Band IV Middle channel=1413 channel=1732.6MHz | | | | | |
|--|------------------|-----------------|--------|-------------|--------|
| Voltage (V) | Temperature (°C) | Frequency error | | Limit (ppm) | Result |
| | | Hz | ppm | | |
| 3.85 | -30 | -14 | -0.008 | ±2.5 | Pass |
| | -20 | 0 | 0.000 | | |
| | -10 | 15 | 0.009 | | |
| | 0 | 6 | 0.003 | | |
| | 10 | -19 | -0.011 | | |
| | 20 | 4 | 0.002 | | |
| | 30 | -9 | -0.005 | | |
| | 40 | -8 | -0.005 | | |
| 50 | 13 | 0.007 | | | |
| 4.20 | 25 | 3 | 0.002 | | |
| End point 3.40 | 25 | -18 | -0.010 | | |

| Reference Frequency: WCDMA Band V Middle channel=4182 channel=836.6MHz | | | | | |
|--|------------------|-----------------|--------|-------------|--------|
| Voltage (V) | Temperature (°C) | Frequency error | | Limit (ppm) | Result |
| | | Hz | ppm | | |
| 3.85 | -30 | -4 | -0.005 | ±2.5 | Pass |
| | -20 | -4 | -0.005 | | |
| | -10 | -7 | -0.008 | | |
| | 0 | -16 | -0.019 | | |
| | 10 | -13 | -0.016 | | |
| | 20 | -10 | -0.012 | | |
| | 30 | -3 | -0.004 | | |
| | 40 | -1 | -0.001 | | |
| 50 | -7 | -0.008 | | | |
| 4.20 | 25 | 0 | 0.000 | | |
| End point 3.40 | 25 | 3 | 0.004 | | |

4 Test Setup Photos of the EUT



5 External and Internal Photos of the EUT

Reference to the test report No. CTA24052000601.

***** End of Report *****