



SPECIFICATION FOR APPROVAL

产品规格承认书

CUSTOMER:

(客户名称)

CUSTOMER P/N:

(客户型号)

MPA2-G50-9.5uH-45

DESCRIPTION/SPEC:

(品名/规格)

TX MPA2 coil module (lead length 45mm)

PART NUMBER:

(产品编号)

MPA2-G50-9.5uH-45

SAMPLE DATE:

(送样日期)

APPROVAL SIGNATURE (供应商承认签章)

制作	检查	审核
谢新香	冯斌丽	张志强

APPROVAL SIGNATURE (客户承认签章)

日期

Xingning Mujianwang Electronic Technology Co., Ltd.

Address: No. 52-54, Zhanqian Road, Luofuwei Town, Xingning City

变更记录

版本	变更内容	日期
A	新版文件	2022/07/26

1. DIMENSIONS & MARKING(UNIT:mm):

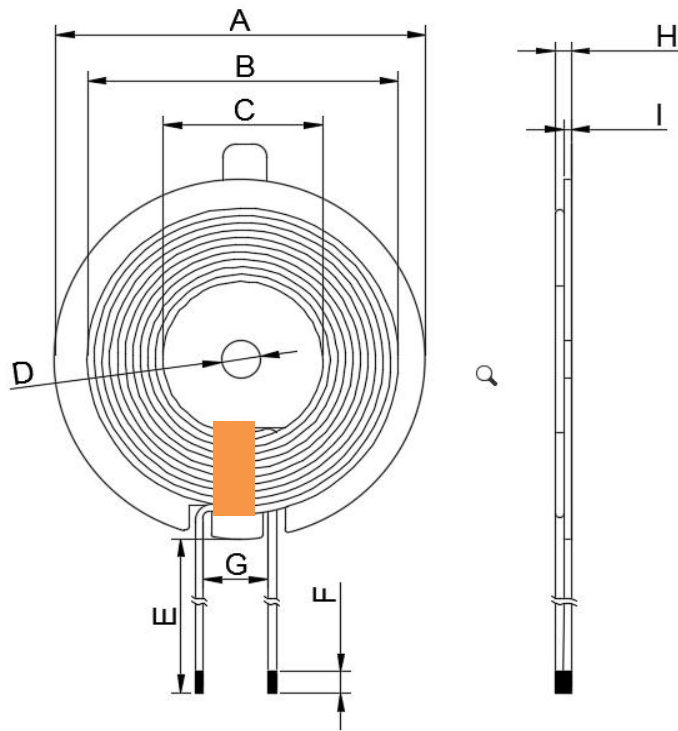

项目	规格
A	50±0.5
B	45±1.0
C	20.5±0.5
D	5.3±0.5
E	45±2.0
F	3.0±1.0
G	10.0 TYP
H	2.8 MAX (不含离型纸厚度)
I	1.0±0.5 (不含离型纸厚度)

备注:

- 1.1. 线圈交叉出线，包7mm宽茶色高温胶带；
- 1.2. 磁片背贴双面胶（48*5.5*0.08mm）

2. SCHEMATICS:

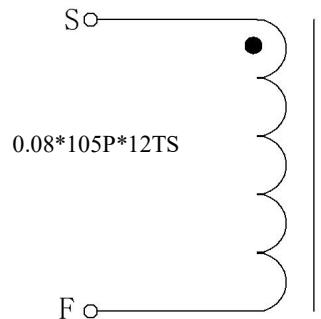

3.WINDING INSTRUCTION & DESCRIPTION:

序号 No.	起头 S	收尾 F	圈数 TURNS	丝包线 WIRE	高温胶带 HIGH TEMPERATURE TAPE	绕线方式 WINDING DIRECTION
L1	S	F	12 圈 1 层	0.08*105P	7mm TYP	反绕

4. ELECTRICAL SPECIFICATIONS @25°C:

4. 1. OCL: S-F=9.5uH±10% @100KHz/1V;
4. 2. RDC: S-F =55mΩ Max。