

XELON

AUDIO



Car Multimedia Player

XA-M728CP

USER MANUAL

Table of contents

Wiring Diagram	2
General Operation	3
AM/FM Tuner Operation	4
Multimedia player	5
AUX in/Rearview lens	5
Phone Link Software	6
Setting Menu	7
Troubleshooting	8
Systematic Parameter	9

! WARNING

For your safety, the driver should not operate the controls while driving. Also, while driving, keep the volume to a level at which external sounds can be heard.

precautions

1. when the interior of the car is extremely cold and the unit is used soon after switching on the heater and moisture may form on the unit and as a result ,the player and proper playback may not be possible.
Wipe any moisture off with a soft cloth.
2. Driving on extremely bumpy or rough roads can cause the disc to skip during playback
3. This unit uses precision parts and components for its operation .In the event that trouble arises ,never open the case ,disassemble the unit ,or lubricate the rotating parts .Contact your service center.

FCC Warning

This device complies with part 15 of the FCC Rules. Operation is subject to the following two conditions:(1) This device may not cause harmful interference, and (2) this device must accept any interference received, including interference that may cause undesired operation.

Any Changes or modifications not expressly approved by the party responsible for compliance could void the user's authority to operate the equipment.

This equipment has been tested and found to comply with the limits for a Class B digital device, pursuant to part 15 of the FCC Rules. These limits are designed to provide reasonable protection against harmful interference in a residential installation. This equipment generates uses and can radiate radio frequency energy and, if not installed and used in accordance with the instructions, may cause harmful interference to radio communications. However, there is no guarantee that interference will not occur in a particular installation. If this equipment does cause harmful interference to radio or television reception, which can be determined by turning the equipment off and on, the user is encouraged to try to correct the interference by one or more of the following measures:

- Reorient or relocate the receiving antenna.
- Increase the separation between the equipment and receiver.
- Connect the equipment into an outlet on a circuit different from that to which the receiver is connected.
- Consult the dealer or an experienced radio/TV technician for help.

FCC RF exposure statement:

The equipment complies with FCC radiation exposure limits set forth for an uncontrolled environment. This equipment should be installed and operated with minimum distance between 20cm the radiator your body.

Wiring- Back Panel:

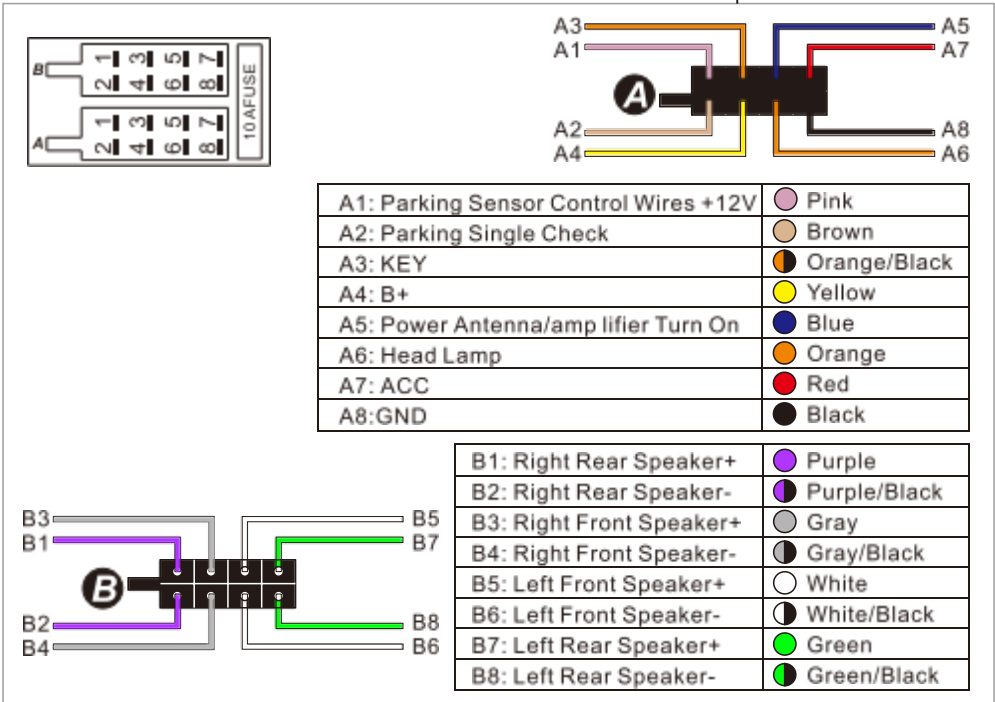
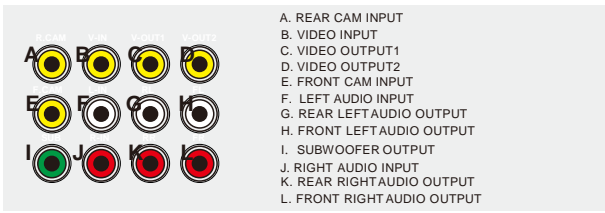
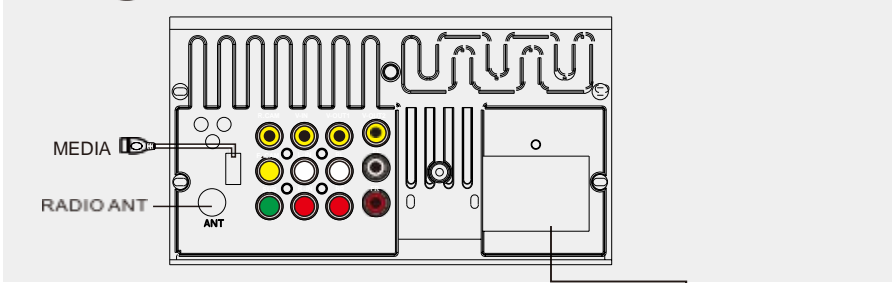

⚠ Please check the speaker line carefully before installation. If any grounding or touching, please connection again, otherwise the unit will be burned.

General Operation



Note: if there is no any device connection , some icons like camera will be showed no device.click is invalid in this case .Display setting is invalid if there is no audio or video playing

Radio

- Radio Region-Set the unit for one for the following regions: Europe, America, China, Russia, Japan, RDS(on/off)

Multimedia player

- Support lots of video and audio formats
- Subwoofer-Turn the subwoofer Output On or Off
- EQ-setting :Pop ,ROCK ,Classic ,Jazz or off

Time

- slide the figures in the set time interface

Language

- * Language-Select desired language(English, Spanish, Deutsch, Russian, Portuguese , French, Chinese,etc.

camera input

- Connect the camera with this device, can be auto detected brake signal when reversing.(Note camera is not included)

car logo

- Preset car logo to match your car brand

Steering wheel control

- Set the function button on you steering wheel via the system learning setting

calibration

- Calibration Press the enter of the "+" as the indicated on the screen to calibrate the touch screen

Power saving mode

AUX Input

- Connect an optional audio video source to the Aux input

FM Tuner Operation

Radio interface RDS turn on function

Touch Radio icon in main interface or press mode key in panel/SRkey in remote controller to switch to radio mode.



Multimedia player

Support avarity of audio and video formats

Music interface

The system will automatically read certain devices inputted into the unit
The user can directly click options in directory menu to perform play.

Note: Sliding the controlling bar in the bottom to show the next page.

AUX in(Auxiliary device input

Click " AUX In" in from the main interface SRC key in remote control to switch to AUX in Mode. AUX in enables external media sources to connect to the system, like camera, video games, etc (controlled by remote control). No auxiliary device input shows at the below picture. Connect external devices through the 3.5mm auxiliary audio/video input. It can display the corresponding picture as the output video.

Rear view Camera

Auto operation: After connect with reverse camera, it will auto-detected the reverse signal and show the reverse pictures. The system will swift to any mode to rear view lens mode automatically. When reverse is over, the system will come back to previous mode.

PHONE connects your device to your mobile phone through the standard port and transfers the picture and audio from the phone to the device. You can control the phone through the device's screen , such as receiving calls, dialing calls, listening to music, watching movies or photos.

Connect your device using the with original cable your phone came with, then touch the phone icon to open the menu, and follow the instructions.

setting

Note:sliding the bar on the left side to see more optional settings



Connect the steering wheel control cable, and click the corresponding key to activate the function.

After entering into the steering wheel control interface, then keep pressing the steering wheel "VOL+" button in your car, at the same time click "VOL+" in the interface, it will be selected, then it is finish this setting. Click other buttons according this method, the steering wheel function can be used.

Troubleshooting

Phenomenon	Reasons	Solutions
Normal		
Not operating	Fuse of machine power supply and auto vehicle battery is burnt, Voltage of power supply is overloaded Automatic protection system avoids fault due to illegal operation Wrong pin assignment ISO connector	Change for fuse of the collect types; Adjust voltage; Reset the system by pressing the Resetkey Check the wiring diagram
Remote control doesn't work	Battery is out of power; Battery is not placed correctly	Change new battery; Reinstall battery
Noor low sound	Disconnection; Volume setting is low volume; wrong connection of Silence; Loudspeaker fault; Volume balance setting bias Earthing in loudspeaker connection	Check the connection; Increase the volume; Reconnection the silence wire complied with the installation instruction; Change for a new loudspeaker; Adjust the volume balance setting to middle place;
Machine reset by itself when it is shutdown	Connection of ACC and B+ is not correct.	Check and reconnect ACC and B+
Turnover screen		
Turnover screen does not open automatically.	Auto Open of turnover screen setting is OFF.	Auto Open»ON
No image	Connection of brake wire is not correct; Not brake state	Connect brake wire with cathode of power supply correctly; Keep brake state after car is placed safe.
Unstable output of images	does not correspond with the present system video setting; Video signal line is not connected correctly.	Adjust system video setting; Check and make sure of the connectivity. Unsupported code
Images being stretched or compression	Inappropriate image proportion setting	Adjust image setting
Trouble		
Radio		
Weak signal	Auto antenna does not reach out completely LOG function is under working state	Connect auto antenna line correctly; Close LOG function.

Note: This device is a Mechless unit.

systematic parameters

specifications

working voltage : direct current 12v

working voltage range : 10.8v-16v

Maximum working electronic current : 10A

Installation angle: less than 30 degree
tilted the front side and back side

power output: 4 x 80 w

impedance 4ohm

SNR: 70dBA

Frequency Response : 20HZ-20KHZ

video

standards: NTSC .PAL (Autorecognition)

output : 2vp-p (75ohm)

Input : 1vp-p (75ohm)

FM Radio

Frequency modulation
87.5MHZ~108.0MHZ (Europe)

Flexibility (-30dB): 10dBU
SNR (-50dB): 15dBU

Frequency sound range:
30HZ~15KHZ (+3dB)

AM Radio

Frequency range
522KHZ-1620KHZ (Europe)

sensitivity (SN=20dB): 20dBU

Image rejection : 60dB

Frequency response:
50HZ-2KHZ (+-3dB)

Display

screen type: TFT

Response time : up=30millisecond
Down=50millisecond

Angle range: depression angle=65
elevation angle=40
Left vision=65 right vision=65

Environment temperature

operation temperature: -20~+70°C

Maintenance temperature: -30°C~80°C

operating humidity: 45%~+80%. c
(relative humidity)

Maintenance humidity: 30%~90%
(relative humidity)