

1.6X0.8X0.5 (mm) WiFi/Bluetooth Ceramic Chip Antenna (MB1608H1) Engineering

Specification 1. Product Number

MB	1608	H1	-01	-R
1	2	3	4	5



2. Features

(1)Product Type	Chip Antenna
(2)Size Code	1.6x0.8x0.5mm
(3)Type Code	H1
(4)Packing	Paper &Reel
(5)Frequency	2.45GHz



明博电子有限公司

LOTUS ANTENNA TECHNOLOGY CO.,LTD

TITLE : 1.6x 0.8 x0.5(mm) WiFi/Bluetooth Ceramic Chip
Antenna (MB1608H1) Engineering Specification

DOCUMENT
NO.

MB1608H1-01-R

REV.
A

- *Stable and reliable in performances
- *Low temperature coefficient of frequency
- *Low profile, compact size
- *RoHS compliance
- *SMT processes compatible

3. Applications

- *Bluetooth earphone systems
- *Hand-held devices when WiFi /Bluetooth functions are needed, e.g., Smart phone.
- *IEEE802.11 b/g/n
- *ZigBee
- *Wireless PCMCIA cards or USB dongle

4. Description

MINGBO chip antenna series are specially designed for WiFi/Bluetooth applications. Based on MINGBO proprietary design and processes, this chip antenna has excellent stability and sensitivity to consistently provide high signal reception efficiency.

5. Electrical Specifications (40 x 40 mm² ground plane)

5-1. Electrical Table

Characteristics		Specifications	Unit
Outline Dimensions		1.6x0.8x0.5	mm
Working Frequency		2400~2500	MHz
VSWR		2 Max.	
Impedance		50	Ω
Polarization		Linear Polarization	
Gain	Peak	1.5 (typical)	dBi
	Efficiency	65 (typical)	%



明博电子有限公司

LOTUS ANTENNA TECHNOLOGY CO., LTD

**TITLE : 1.6x 0.8 x0.5(mm) WiFi/Bluetooth Ceramic Chip
Antenna (MB1608H1) Engineering Specification**

**DOCUMENT
NO.**

MB1608H1-01-R

**REV.
A**

5-2. Return Loss & VSWR

Return Loss (S₁₁)

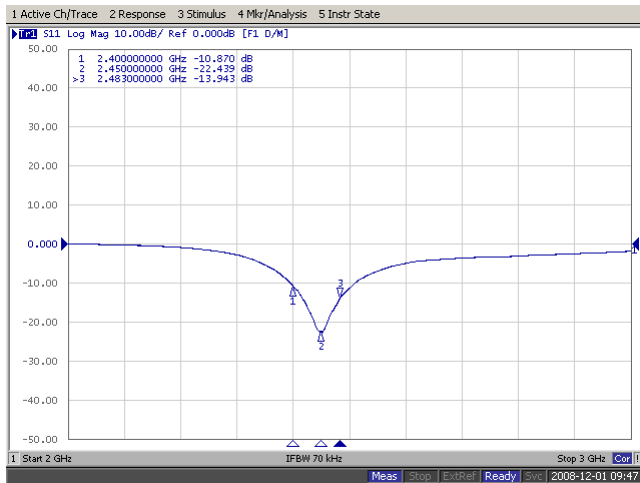

VSWR(S₁₁)

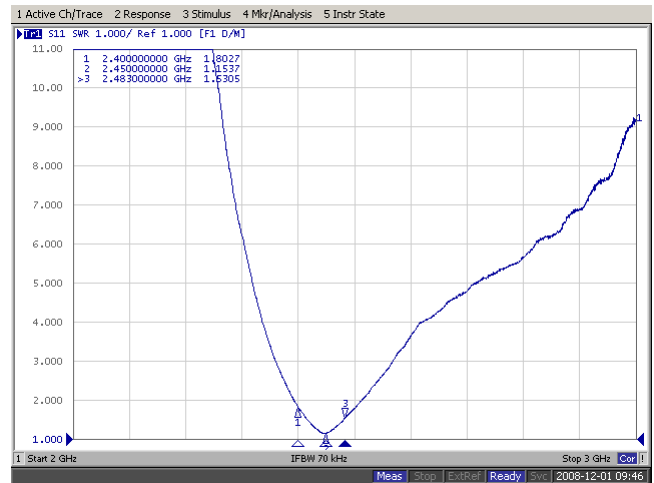

6. Antenna Dimensions (unit: mm)

a. Antenna Dimensions

Applications

1. Bluetooth
2. Wireless LAN
3. ISM band 2.4GHz wireless applications

Dimensions (Unit: mm)

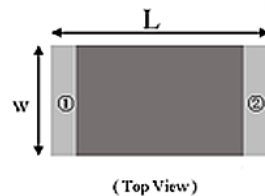

Number	Terminal Name
①	INPUT
②	NC

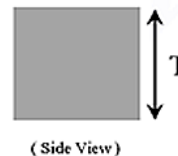
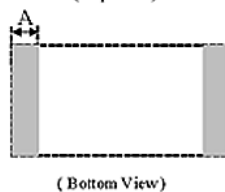

Symbols	L	W	T	A
Dimensions	1.60 ± 0.20	0.80 ± 0.20	0.5 ± 0.20	0.30 ± 0.10



明博电子有限公司

LOTUS ANTENNA TECHNOLOGY CO., LTD

**TITLE : 1.6x 0.8 x0.5(mm) WiFi/Bluetooth Ceramic Chip
Antenna (MB1608H1) Engineering Specification**

**DOCUMENT
NO.**

MB1608H1-01-R

**REV.
A**

7. Radiation Pattern (80 x 40 mm² ground plane)

7-1. 3D Gain Pattern @ 2442 MHz

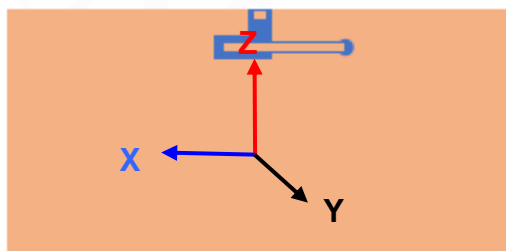
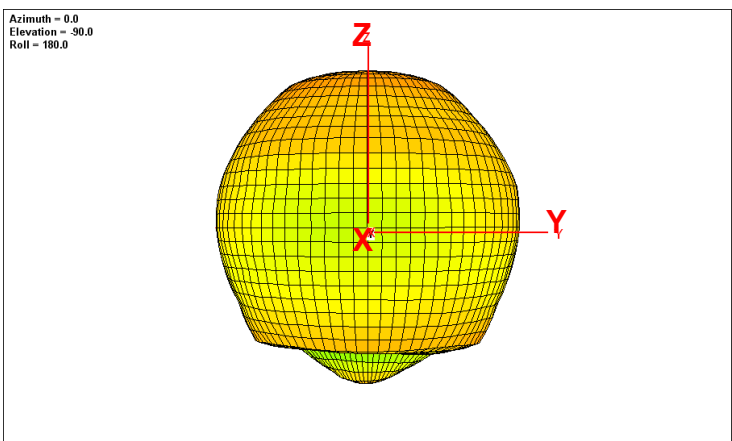
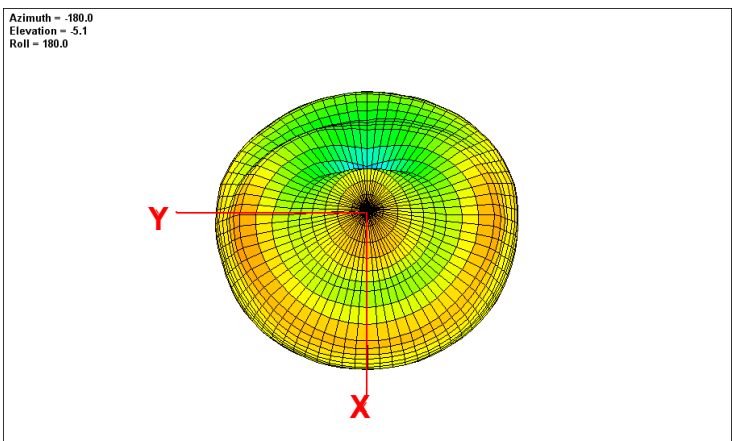
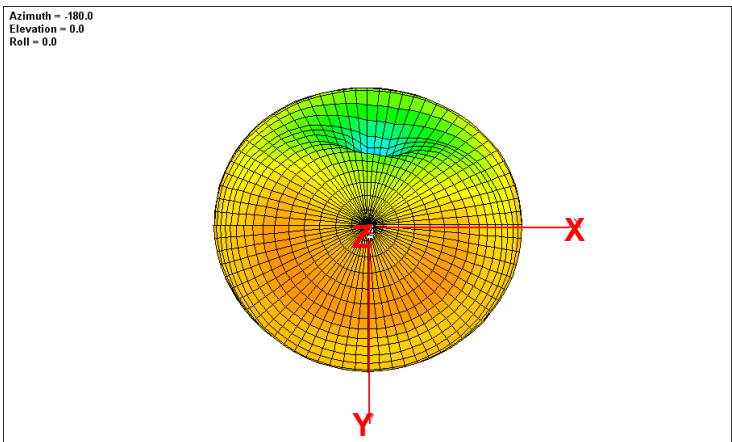

明博电子有限公司

LOTUS ANTENNA TECHNOLOGY CO., LTD

TITLE : 1.6x 0.8 x0.5(mm) WiFi/Bluetooth Ceramic Chip Antenna (MB1608H1) Engineering Specification

DOCUMENT NO.

MB1608H1-01-R

REV. A

7-2. 3D Efficiency Table

Frequency(MHz)	2400	2410	2420	2430	2442	2450	2460	2470	2480	2490	2500
Efficiency (dB)	-1.4	-1.0	-0.9	-0.7	-0.7	-0.8	-0.9	-1.1	-1.2	-1.3	-1.4
Efficiency (%)	62.8	63.7	64.3	64.4	65.5	65.0	64.0	63.6	63.1	62.6	61.5
Gain (dBi)	1.1	1.2	1.3	1.4	1.5	1.5	1.4	1.3	1.2	1.1	1.1

7-3. 3D Efficiency vs. Frequency

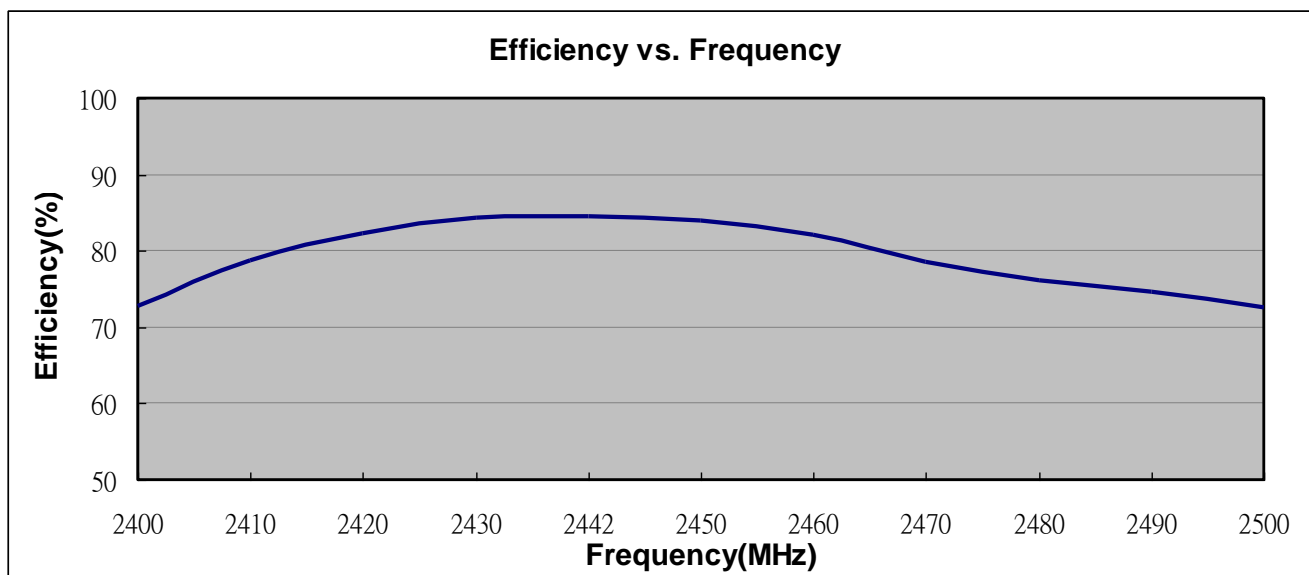

8. Layout Guide

a. Solder Land Pattern:

Land pattern for soldering (gray marking areas) is as shown below. Depending on



明博电子有限公司

LOTUS ANTENNA TECHNOLOGY CO., LTD

**TITLE : 1.6x 0.8 x0.5(mm) WiFi/Bluetooth Ceramic Chip
Antenna (MB1608H1) Engineering Specification**

**DOCUMENT
NO.**

MB1608H1-01-R

**REV.
A**

Customer's requirement, matching circuit as shown below is also recommended.

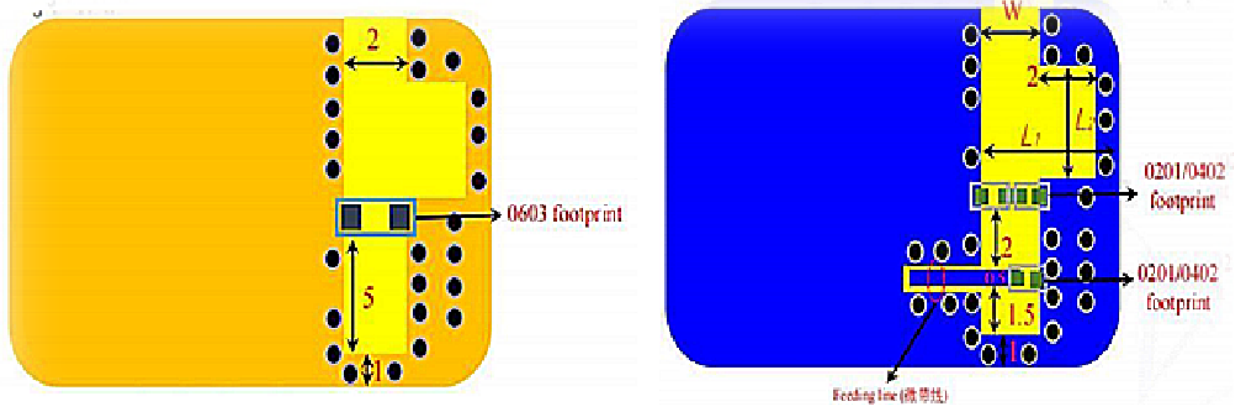

明博电子有限公司

LOTUS ANTENNA TECHNOLOGY CO., LTD

TITLE : 1.6x 0.8 x0.5(mm) WiFi/Bluetooth Ceramic Chip Antenna (MB1608H1) Engineering Specification

DOCUMENT NO.

MB1608H1-01-R

REV. A

Evaluation Board and Matching Circuits

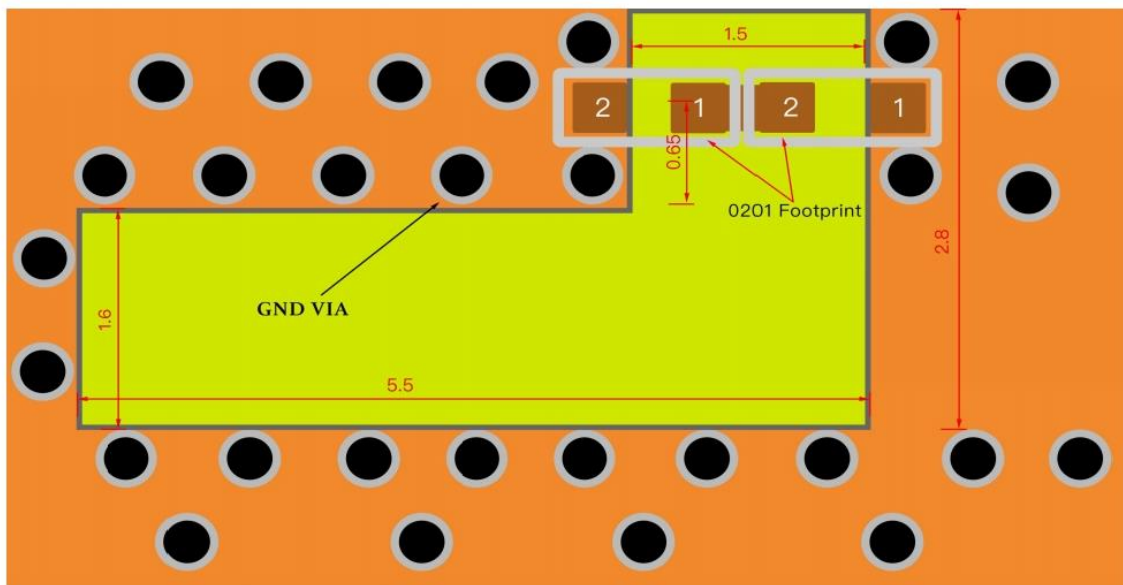
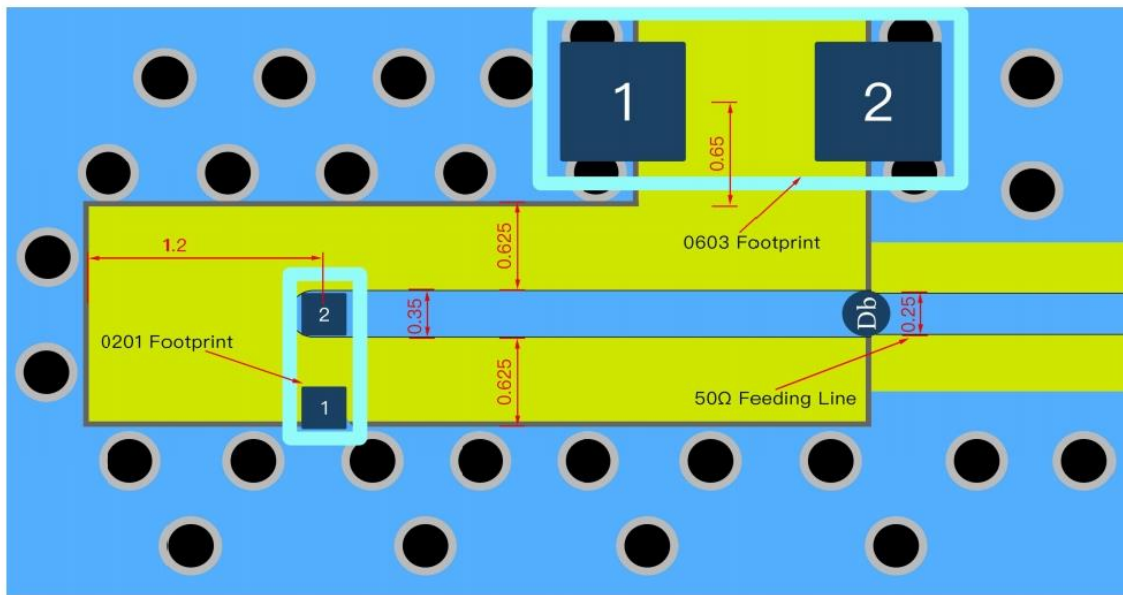

Bottom View

Unit : mm

c. Fine tuning element vs. Center frequency



明博电子有限公司

LOTUS ANTENNA TECHNOLOGY CO., LTD

TITLE : 1.6x 0.8 x0.5(mm) WiFi/Bluetooth Ceramic Chip
Antenna (MB1608H1) Engineering Specification

DOCUMENT
NO.

MB1608H1-01-R

REV.
A

PAGE 7 OF 11

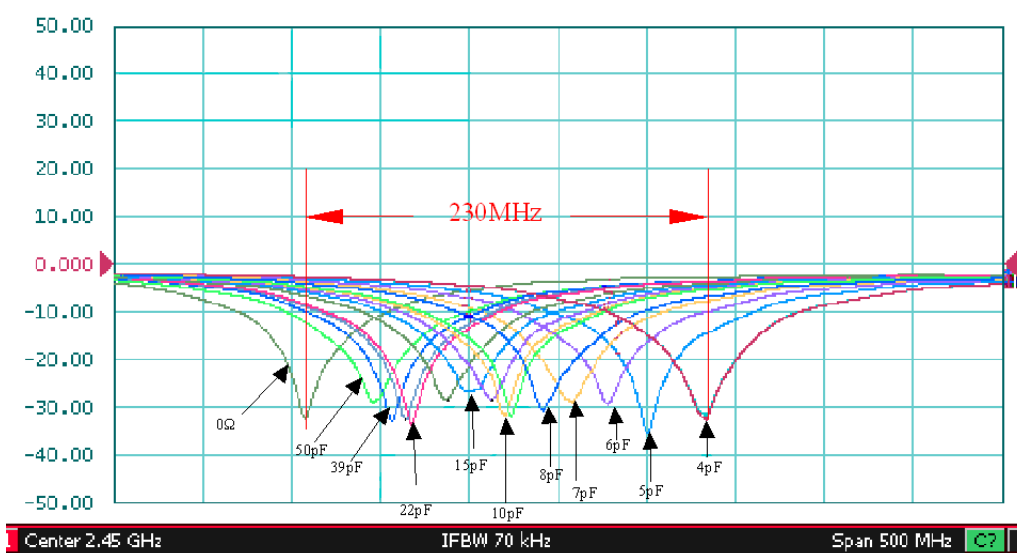

9. Soldering Conditions

a. Typical Soldering Profile for Lead-free Process

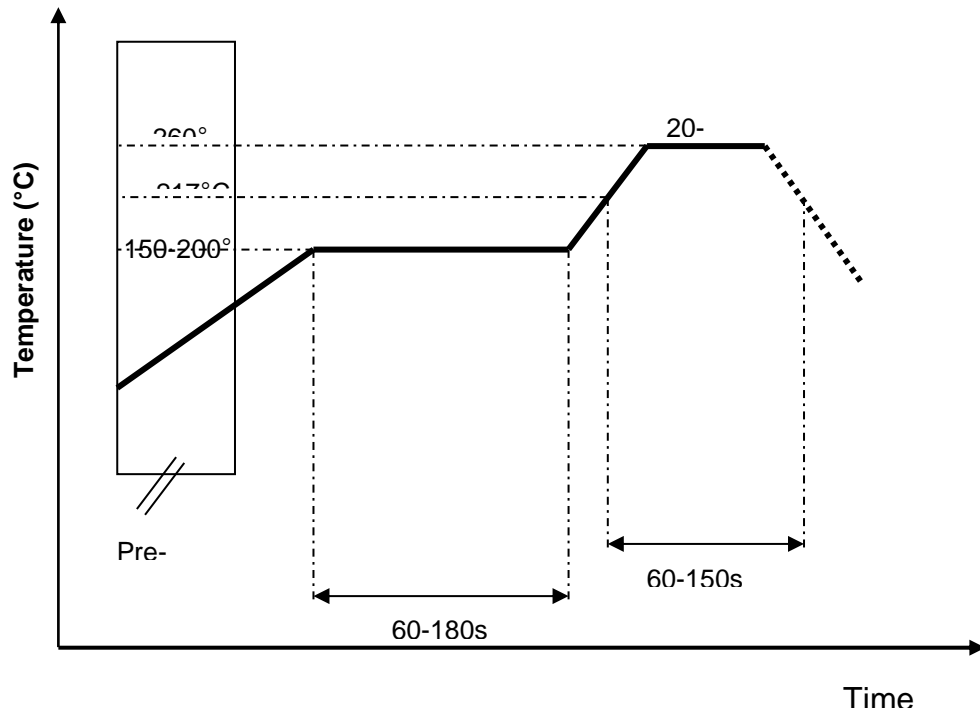

明博电子有限公司

LOTUS ANTENNA TECHNOLOGY CO., LTD

Packing

- (1) Quantity/Reel: 5000 pcs/Reel
- (2) Plastic tape:

Dimensions of paper taping

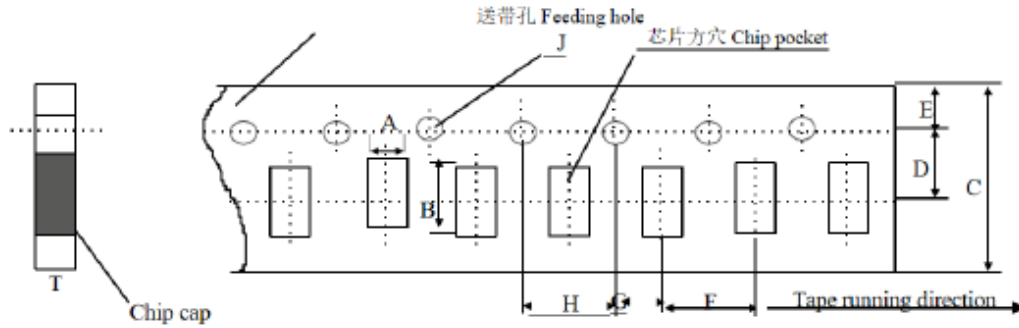

Unit: mm

代号 Code 纸带规格 papersize	A	B	C	D*	E	F	G*	H	J	T
尺寸	1.10 ±0.10	1.90 ±0.10	8.00 ±0.10	3.50 ±0.05	1.75 ±0.10	4.00 ±0.10	2.00 ±0.10	4.00 ±0.10	1.50 +0/-0.10	1.10 Max

Reel (4000 pcs/Reel)

EMBOSED TAPING

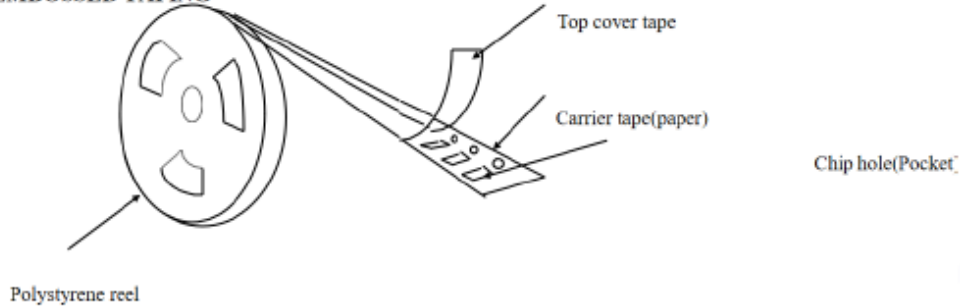

Storage Period

The guaranteed period for solderability is 6 months (Under deliver package condition).
Temperature: 5~40°C /Relative Humidity: 20~70%



明博电子有限公司

LOTUS ANTENNA TECHNOLOGY CO., LTD

TITLE : 1.6x 0.8 x0.5(mm) WiFi/Bluetooth Ceramic Chip
Antenna (MB1608H1) Engineering Specification

DOCUMENT
NO.

MB1608H1-01-R

REV.
A

Reliability Table

Test Item	Procedure	Requirements Ceramic Type	Remark (Reference)
Electrical Characterization		Fulfill the electrical specification	User Spec.
Thermal Shock	1. Preconditioning: 50 ± 10°C / 1 hr, then keep for 24 ± 1 hrs at room temp. 2. Initial measure: Spec: refer Initial spec. 3. Rapid change of temperature test -30°C to +85°C; 100 cycles; 15 minutes at Lower category temperature; 15 minutes at Upper category temperature.	No Visible Damage. Fulfill the electrical specification.	MIL-STD-202 107
Temperature Cycling	1. Initial measure: Spec: refer Initial spec. 2. 100 Cycles (-30°C to +85°C), Soak Mode=1 (2 Cycle/hours). 3. Measurement at 24 ± 2Hours after test condition.	No Visible Damage. Fulfill the electrical specification.	JESD22 JA104
High Temperature Exposure	1. Initial measure: Spec: refer Initial spec. 2. Unpowered; 500hours @ T=+85°C. 3. Measurement at 24 ± 2 hours after test.	No Visible Damage. Fulfill the electrical specification.	MIL-STD-202 108
Low Temperature Storage	1. Initial measure: Spec: refer Initial spec. 2. Unpowered; 500hours @ T= -30°C. 3. Measurement at 24 ± 2 hours after test.	No Visible Damage. Fulfill the electrical specification.	MIL-STD-202 108
Solderability (SMD Bottom Side)	Dipping method: a. Temperature: 235 ± 5°C b. Dipping time: 3 ± 0.5s	The solder should cover over 95% of the critical area of bottom side.	IEC 60384-21/22 4.10
Soldering Heat Resistance (RSH)	Preheating temperature: 150 ± 10°C. Preheating time: 1~2 min. Solder temperature: 260 ± 5°C. Dipping time: 5 ± 0.5s	No Visible Damage.	IEC 60384-21/22 4.10



明博电子有限公司

LOTUS ANTENNA TECHNOLOGY CO., LTD

TITLE : 1.6x 0.8 x0.5(mm) WiFi/Bluetooth Ceramic Chip
Antenna (MB1608H1) Engineering Specification

DOCUMENT
NO.

MB1608H1-01-R

REV.
A

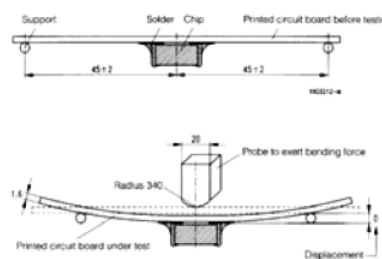
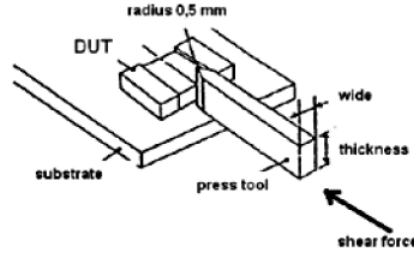
Board Flex (SMD)	<p>1. Mounting method: IR-Reflow. PCB Size (L:100 × W:40 × T:1.6mm)</p> <p>2. Apply the load in direction of the arrow until bending reaches 2 mm.</p> 	No Visible Damage.	AEC-Q200 005
Adhesion	<p>Force of 1.8Kg for 60 seconds.</p> 	No Visible Damage Magnification of 20X or greater may be employed for inspection of the mechanical integrity of the device body terminals and body/terminal junction.	AEC-Q200 006
Physical Dimension	<p>Any applicable method using x10 magnification, micrometers, calipers, gauges, contour projectors, or other measuring equipment, capable of determining the actual specimen dimensions.</p>	In accordance with specification.	JESD22 JB100



明博电子有限公司

LOTUS ANTENNA TECHNOLOGYCO.,LTD

TITLE : 1.6x 0.8 x0.5(mm) WiFi/Bluetooth Ceramic Chip Antenna (MB1608H1) Engineering Specification

DOCUMENT NO.

MB1608H1-01-R

REV. A