

FCC Test Firm Designation Number: FR0014
ISED Wireless Device Testing Laboratory CAB Number: FR0004

Matériel testé :
Equipment under test:

EDITAG / mBase
(Trademark / Marketing name or product reference)

Demandeur de certification : **EDITAG**
Applicant for certification: Europarc Sainte-Victoire Bât 12, Route de Valbrillant,
13590 Meyreuil – France

Client : **ALWAYS WIRELESS**
Customer: Batiment Epicentre,
38660 Saint-Vincent-de-Mercuze – France

Numéro d'affaire : OF-10021
Work number :

Référence de la proposition : 012022-25243-1
Proposal number:

Date de l'essai : Du 4 au 10 Janvier 2024
Date of test: January 4th to 10th, 2024

Objectif des essais : EMC qualification accordingly to following standards:
Test purpose: - CFR 47, FCC Part 15, Subpart C
(Chapter 15.247 - Operation within the bands 902–928 MHz, 2400–2483.5 MHz, and 5725–5850 MHz)
- Industry Canada RSS-247, Issue 3
(Digital Transmission Systems Operating in the Bands 902–928 MHz)
Measurement standards:
ANSI C63.10 (2013)

Lieu du test: SMEE - 385 rue René Rambaud, ZA le Parvis 2
Test location: 38500 VOIRON - France

Test réalisé par : Chemseddine KERMICHE
Test realized by:

Conclusion : L'équipement satisfait aux prescriptions et essais des normes citées en référence.
Conclusion: *The appliance complies with requirements and tests of above mentioned standards.*

Ed.	Date	Modifications / Pages	Written by : Visa	Approved by: Visa
1	January 23, 2024	Initial Edition	Chemseddine KERMICHE <i>Test operator</i>	Laurent Chapus <i>Technical Manager</i>

La copie de ce document n'est permise que sous sa forme intégrale. Ce document est le résultat d'essais effectués sur un échantillon. Il ne préjuge pas de la conformité de l'ensemble des produits fabriqués à l'objet essayé. Pour la déclaration de conformité de l'équipement, il n'est pas tenu compte de l'incertitude de mesure. Cette nouvelle édition de ce rapport annule et remplace l'édition précédente. Les modifications apportées à une nouvelle édition de ce rapport sont signalées par un trait vertical à gauche de la page. L'utilisation de la marque d'accréditation COFRAC est interdite.
This document shall not be reproduced, except in full. This document contains results related only to the item tested. It does not imply the conformity of the whole production to the item tested. For the declaration of conformity of the equipment, the measurement uncertainty is not taken into account. This new edition of this report cancels and replaces the previous edition. Changes made to a new edition of this report are indicated by a vertical line to the left of the page. The use of the COFRAC accreditation mark is prohibited.



Accréditation
N° 1-6356
Portée disponible sur :
Scope available on :
www.cofrac.fr

COORDONNEES

SMEE
385, Rue René Rambaud, ZA Le Parvis 2
38500 VOIRON - France

TEL : 04 76 65 76 50
FAX : 04 76 66 18 30

SAS au capital de 50 000 € / RC Grenoble B534 796 453 / SIRET 534 796 453 00015 / code APE 7490B / n° TVA : FR 59 534 796 453

Contents

1.	NORMATIVES REFERENCES.....	3
2.	TEST SYNTHESIS	4
3.	EQUIPMENT UNDER TEST (EUT)	5
4.	TEST CONDITIONS	6
5.	MODIFICATIONS OF THE EUT	6
6.	SPECIAL ACCESSORY	6
7.	MEASUREMENT UNCERTAINTY.....	6
8.	FIELD STRENGTH CALCULATION	6
9.	TEST SETUP DIAGRAM.....	7
10.	TEST EQUIPMENT LIST.....	9
11.	CONDUCTED EMISSION MEASUREMENT (150 KHZ-30MHZ)	10
12.	6DB BANDWIDTH	13
13.	FUNDAMENTAL EMISSION OUTPUT POWER.....	15
14.	MAXIMUM POWER SPECTRAL DENSITY LEVEL IN THE FUNDAMENTAL EMISSION	17
15.	UNWANTED EMISSIONS IN NON-RESTRICTED FREQUENCY BANDS (RADIATED EMISSIONS)	19
16.	UNWANTED EMISSIONS IN RESTRICTED FREQUENCY BANDS	22
17.	OCCUPIED BANDWIDTH (99%)	29

1. Normatives References

FCC qualification according to:		
Standards	Applied	Title
ANSI C63.10 (2013)	X	American National Standard for Testing Unlicensed Wireless Devices
CFR47, Part 15 (January 2024)	X	Telecommunication – Federal Communication Commission – Radio frequency devices, Sections 15.109 / 15.209 / 15.247

ISED qualification according to:		
Standards	Applied	Title
RSS-Gen (Issue 5/2018, amendments 2019 and 2021)	X	General Requirements and Information for the Certification of Radio Apparatus
RSS-247 (Issue3/2023)	X	Digital Transmission Systems (DTSs), Frequency Hopping Systems (FHSs) and Licence-Exempt Local Area Network (LE-LAN) Devices

Note: Following guidance are used

- DTS Measurement Guidance 558074 D01 v05r02
- Determining ERP and EIRP Guidance 412172 D01 v01r01

Deviation from standard: None.

2. Test synthesis

TEST	Paragraph number FCC Part 15 / ISED ICES & RSS	Spec. FCC Part 15 / ISED ICES & RSS	RESULTS (comments)
Conducted emissions test	15.207 (a) RSS-Gen § 8.8	Table 15.207 (a) Table 4 / RSS-Gen	PASS
6dB Bandwidth	15.247 (a) (2) RSS-247 § 5.2 (a)	At least 500kHz	PASS
Maximum Peak Output Power	15.247 (b) (3) & (4) RSS-247 § 5.4 (d)	1W max / 30dBm (Conducted) 4W max / 36dBm (EIRP)	PASS
Maximum Power Spectral Density	15.247 (e) RSS-247 § 5.2 (b)	8dBm in a 3kHz band segment	PASS
Unwanted emissions into Non Restricted Frequency Bands	15.247 (d) / RSS-247 § 5.5	-20dBc in any 100kHz outside frequency band.	PASS
Unwanted emissions into Restricted Frequency Bands	15.209 (a) / 15.247 (d) / 15.205 (a) RSS-GEN §8.9, § 8.10 / RSS-247 § 5.5	<u>Measure at 300m</u> 9-490kHz: 2400µV/m/F(kHz) 6.370µA/m/F (kHz) <u>Measure at 30m</u> 0.490-1.705: 24000µV/m/F(kHz) 63.70µA/m/F (kHz) 1.705-30MHz: 30µV/m 0.08µA/m <u>Measure at 3m</u> 30MHz-88MHz : 40 dBµV/m 88MHz-216MHz : 43.5 dBµV/m 216MHz-960MHz : 46.0 dBµV/m Above 960MHz : 54.0 dBµV/m	PASS
Occupied Bandwidth	RSS-GEN § 6.7	BW at 99%	PASS
Antenna requirement	FCC 15.203 RSS-GEN § 6.8		PASS

- General conclusion:**

Measures and tests performed on the sample of the product EDITAG / mBase, in configuration and description presented in this test report, show compliance with standards FCC CFR 47, PART 15, Subpart C and RSS-Gen & RSS-247.

3. Equipment Under Test (EUT)

**Nom /
Identification**

EDITAG / mBase
(Trademark / Marketing name or product reference)

P/N: 02-HW-00112
SN: None.

FCC ID: 2BDZ8-0441
IC: 31762-0441
Product name / PMN: mBase
Model / HVIN: mBase
Firmware version / FVIN 1210

**Alimentation /
Power supply** DC 12V from power supply adapter.
DC 48V from PoE.

**Auxiliaires /
Auxiliaries** Power supply adapter, model: FOSCAM (SAW24-120-2000).
PoE switch, model: NETGEAR GS108PEv3.

**Entrées-Sorties /
Input / Output**

	Câbles pour essai / Cables for test	Blindé / Shielded	Prévu pour >3m / Intended for >3m
AC Mains power supply	1m (2wires)	No	Mains
DC power cable	1.5m (2wires)	No	No
RJ45 cable (Ethernet 10/100 and PoE)	5.0m	Yes	Yes

**Mode de fonctionnement /
Running mode**

Equipment running modes are:
The tested sample can be set in following modes:
- Transmit a modulated carrier frequency at 905.25MHz, 915.25MHz and 925.25MHz
Note: Ethernet was not activated during the entire test.

**Programme de test /
Test program /**

None.

**Informations
supplémentaires /
Additional informations**

Declaration of the applicant:
- Type of technology: Proprietary RF protocol
- Frequency transmission band: 902-928MHz.
- 41 channels used in DTS mode from 905.25 to 925.25MHz / Spacing 500kHz
- Power setting: 10dBm
- Modulation: LORA (CSS) with 500kHz nominal BW
- Equipment intended for use as a mobile station
- Equipment designed for continuous operation
- Antenna type: PCB antenna with max gain 5.2dBi

**Dimensions de l'EST /
Dimensions of EUT**

155mm x 83 x 55
Antenna length is 80mm

Note: The above information are declared by the manufacturer/customer and are under his responsibility.

4. Test conditions

Power supply voltage:
 Equipment under test: DC 12V from power supply adapter or POE (48V)
 Auxiliaries: 120V/60Hz (AC mains for conducted emission).

5. Modifications of the EUT

None.

6. Special accessory

None.

7. Measurement Uncertainty

Test Description	Expanded uncertainty
Conducted emissions test (150k-30MHz, AC mains)	± 3.5dB
Radiated emission test (9kHz-30MHz, electric field)	± 4.0dB
Radiated emission test (30-200MHz, SAC 3m)	± 5.6dB
Radiated emission test (200-1000MHz, SAC 3m)	± 5.3dB
Radiated emission test (1-18GHz, FAC 3m)	± 5.6dB
Radiated emission test (18-40GHz, FAC 3m)	± 5.6dB
Conducted RF output power at antenna port	± 1.6dB
Radiated RF output power (Peak, Power density)	± 5.6dB
DTS Bandwidth, 99% OBW	±4%
Temperature	± 1°C
Time and duty cycle calculation	±1%
AC and DC voltage	±1%

Note: Expanded uncertainty at 95% confidence (k=2)

8. Field Strength Calculation

The field strength (level) is calculated by adding the Antenna Factor and Cable Factor, and subtracting the Amplifier Gain (if any) from the measured reading. The basic equation is as follow:

$$FS = RA + AF + CF - AG$$

Where FS = Field Strength (Level)

RA = Receiver Amplitude (Meter Reading)

AF = Antenna Factor

CF = Cable Factor

AG = Amplifier Gain

Margin value = Emission level – Limit value

Example:

RA: 14.0dBμV / AF: 16.5 dBm⁻¹ / CF: 3.5dB / AG: 15dB

→ Total factor: 5dBm⁻¹

→ Field level: 19.0dBμV/m (-21.0dB for margin if limit is 40dBμV/m)

9. Test Setup Diagram

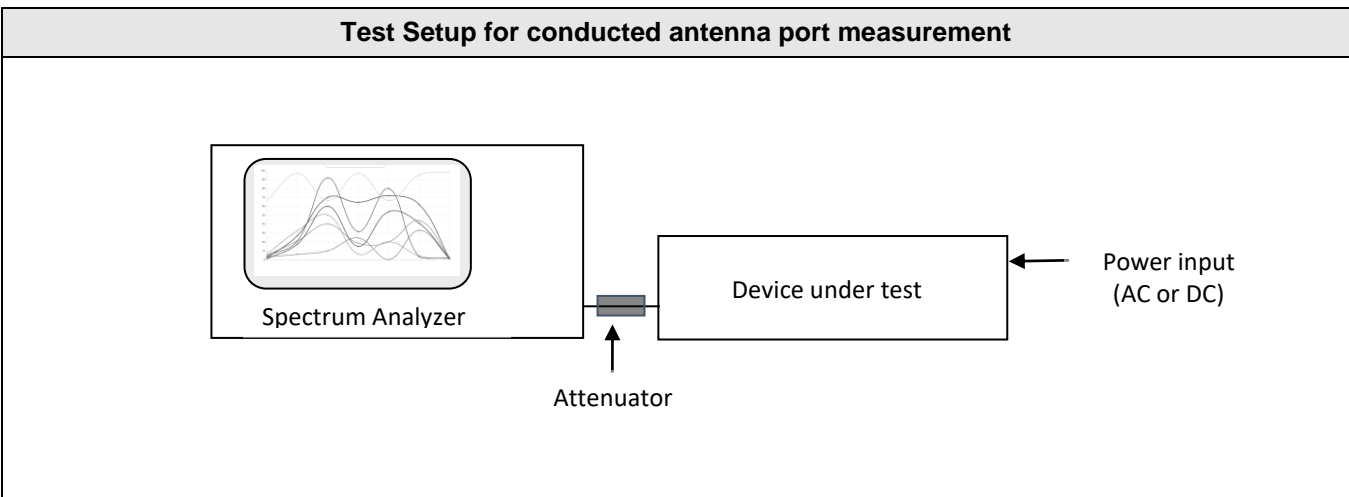
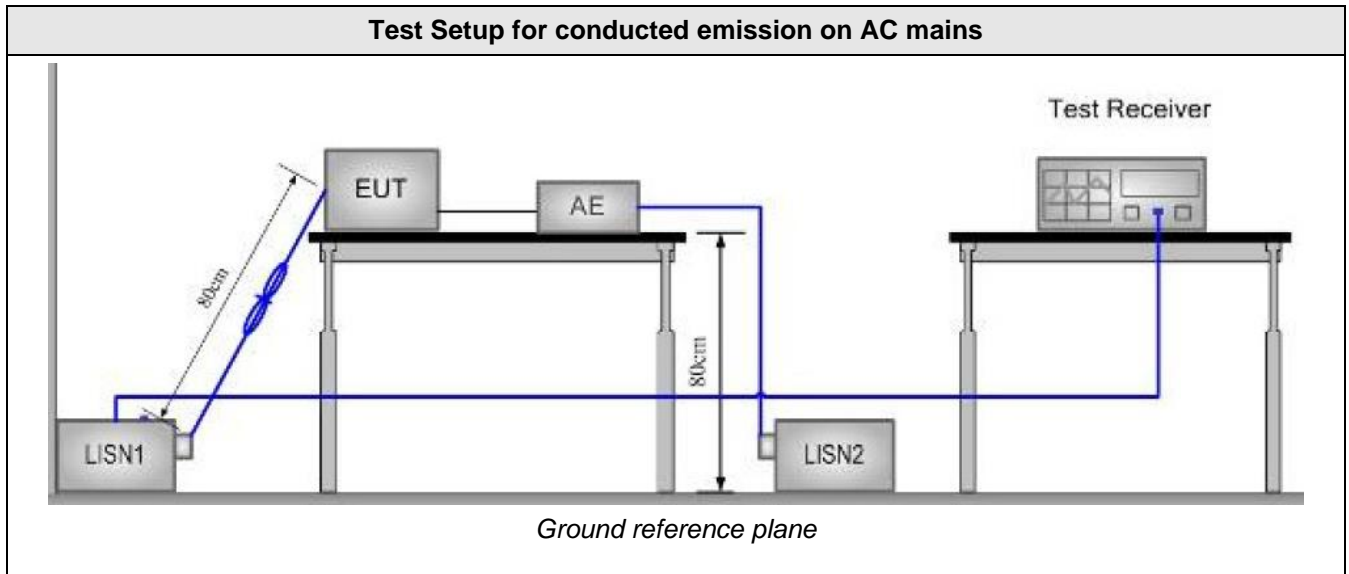

Test Setup for radiated emission

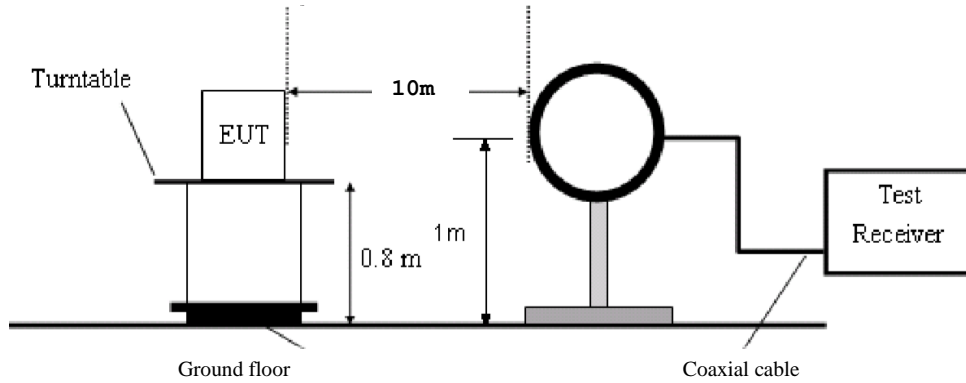

Test setup for 9k-30MHz (FS OATS)

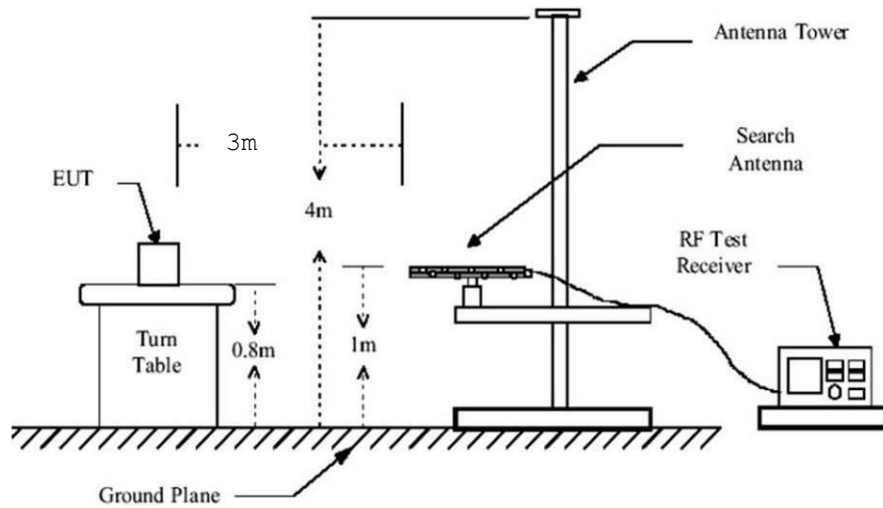

Test setup for 30-1000MHz (SAC 3m)

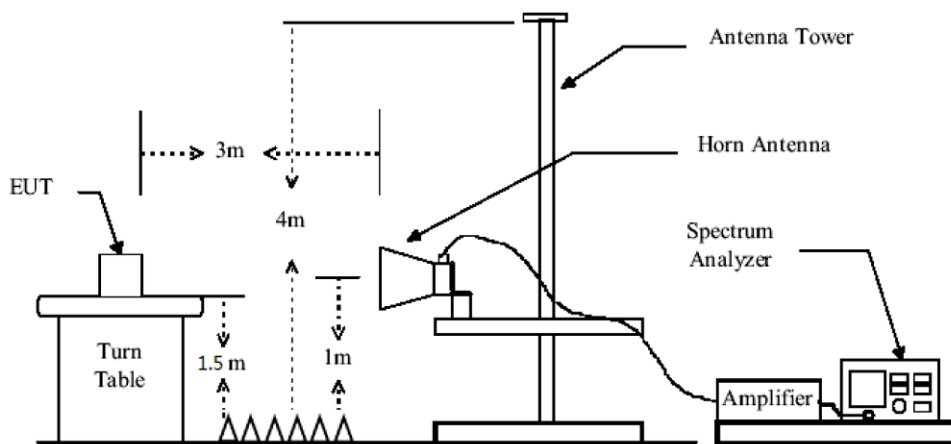

Test setup for 1-10GHz (SAC 3m, tilt antenna mast used)

10. Test Equipment List

Test Equipment Used for conducted emission on AC mains					
Description	Manufacturer	Model	ID	Date Cal.	Nxt. Cal.
AC power supply	PACIFIC POWER	AMX-125	ALI-101-002	2023/8	2024/8
Attenuator / limiter	SMEE	ATT#2	ATT-171-010	2023/4	2024/4
Cable RF	RADIALL	RG58 / BNC	CAB-211-042	2023/4	2024/4
Measuring receiver	Rohde&Schwarz	ESRP	REC-151-002	2021/12	2024/3
LISN (50Ω / 50μH) (Meas.)	AFJ	LS16C	RSI-101-001	2023/7	2025/7
EMC Software	NEXIO	BAT EMC	SOF-101-001	-	-

Test Equipment Used for conducted antenna port measurement					
Description	Manufacturer	Model	ID	Date Cal.	Nxt. Cal.
Measuring receiver	Rohde&Schwarz	ESRP	REC-151-002	2021/12	2024/5
Spectrum analyzer	Rohde&Schwarz	FSV40	ASP-171-004	2021/10	2024/4
RF Attenuator	Mini-Circuit	BW-N10W5+	ATT-171-008	2023/4	2024/4
EMC Software	NEXIO	BAT EMC	SOF-101-001	-	-

Test Equipment Used for radiated measurement					
Description	Manufacturer	Model	ID	Date Cal.	Nxt. Cal.
Log-periodic antenna	EMCO	3146	ANT-191-019	2021/7	2024/1
Biconnic antenna	COM-POWER	AB- 900A	ANT-201-021	2023/1	2025/1
Horn antenna	COM-POWER	AH-118	ANT-101-004	2021/7	2024/7
Loop antenna	EMCO	6502	ANT-101-009	2023/9	2025/9
RF cable	HUBER+SUHNER	SF126E / 2m	CAB-231-043	2023/4	2024/4
RF cable	HUBER+SUHNER	SF104E / 5.3m	CAB-231-044	2023/4	2024/4
RF cable	HUBER+SUHNER	SF126E / 7m	CAB-231-045	2023/4	2024/4
Semi anechoic room	COMTEST	218292	CAG-201-002	2022/4	2025/2
High-Pass filter	Wainwright Inst.	HK6-948-1200	FIL-141-004	2023/4	2024/4
Antenna mast	Innco- Systems	MA4640-XP-ET	MAT-201-002	-	-
Turntable	Innco- Systems	CT0800	PLA-141-001	-	-
Turntable	Innco- Systems	DS1500-S-1t	PLA-201-003	-	-
Pre-amplifier	COM-POWER	1-18GHz	PRE-221-005	2023/4	2024/4
Measuring receiver	Rohde&Schwarz	ESRP	REC-151-002	2021/12	2024/5
Spectrum analyzer	Rohde&Schwarz	FSV40	ASP-171-004	2021/10	2024/4
FS OATS	Div	10m	SIT-201-002	-	-
EMC Software	NEXIO	BAT EMC	SOF-101-001	-	-

11. Conducted Emission Measurement (150 kHz-30MHz)

TEST: Limits for conducted disturbance 150kHz – 30MHz				Verdict	
<p><u>Method:</u> The LISN is placed 0,8 m from the boundary of the unit under test and bonded to a ground reference plane. This distance was between the closest points of the AMN and the EUT. All other units of the EUT and associated equipment were at least 0,8 m from the AMN. All power was connected to the system through Artificial Mains Network (AMN). Conducted voltage measurements on lines were made at the output of the LISN. The EUT is 80cm above the ground reference plane and 40cm from the vertical ground plane. The AC power cable is 1m length.</p>				Pass	
Laboratory Parameters:		Required prior to the test		During the test	
Ambient Temperature		17 to 27°C		21°C ± 2	
Relative Humidity		25 to 65 %		32% ± 5	
Fully configured sample scanned over the following frequency range		Frequency range on each side of line		Measurement Point	
		150kHz to 30MHz		AC input port (120V/60Hz)	
Limits					
Frequency (MHz)		Limit dB (µV)			
		Quasi-Peak	Result	Average	Result
0.15 – 0.50		66 \ 56	PASS	56 \ 46	PASS
0.50 - 5		56	PASS	46	PASS
5 – 30		60	PASS	50	PASS
<p>Supplementary information: Test location: SMEE Test date: January 10th, 2024 by C. KERMICHE. Power supply voltage: 12V DC power supply adapter, powered with 120V 60Hz.</p>					

Tabulated Results for Mains Terminal Disturbance Voltage on AC port

FREQ (MHz)	Meas. PK (dBμV)	Mes. QP (dBμV)	LIMIT QP (dBμV)	Margin QP (dB)	Mes. AV (dBμV)	LIMIT AV (dBμV)	Margin AV (dB)	Line
0.152651	54.13	50.47	65.78	-15.31	32.49	55.78	-23.30	L1
0.186122	49.97	45.65	64.21	-18.57	27.60	54.21	-26.62	L1
0.251777	45.15	40.40	61.76	-21.36	20.78	51.76	-30.98	L1
0.355742	41.57	36.34	58.87	-22.53	18.66	48.87	-30.21	L1
0.153169	54.71	51.18	65.78	-14.60	31.48	55.78	-24.30	N
0.156298	54.03	50.33	65.57	-15.24	29.29	55.57	-26.27	N
0.184651	50.45	46.99	64.21	-17.23	27.70	54.21	-26.52	N
0.216043	47.18	43.96	62.89	-18.93	26.30	52.89	-26.59	N
0.349925	42.55	35.83	58.96	-23.13	18.17	48.96	-30.79	N
Frequency band investigated:			150kHz-30MHz					
RBW:			9kHz					
Voltage:			120V / 60Hz					
Limit:			FCC Part 15.207 / RSS-Gen: Issue 5, §8.8 Table 4					
Final measurement detector:			Quasi-Peak and CISPR Average (AV)					
RESULT:			PASS					
Measured value calculation:			<p>The measured value (level) is calculated by adding the Cable Factor, the Transient suppressor attenuation and LISN attenuation from the receiver amplitude reading. The basic equation is as follow:</p> $\text{Meas.} = \text{RA} + \text{CF} + \text{ATT}_{\text{TRAN}} + \text{ATT}_{\text{LISN}}$ <p>Where Meas. = Level (dBμV) RA = Receiver Amplitude CF = Cable Factor ATT_{TRAN} = Transient suppressor attenuation ATT_{LISN} = LISN attenuation Margin value = Emission level – Limit value</p>					

Graphical representation of Conducted Disturbance Measurement (Peak and Average detection) - AC port -

Line L1

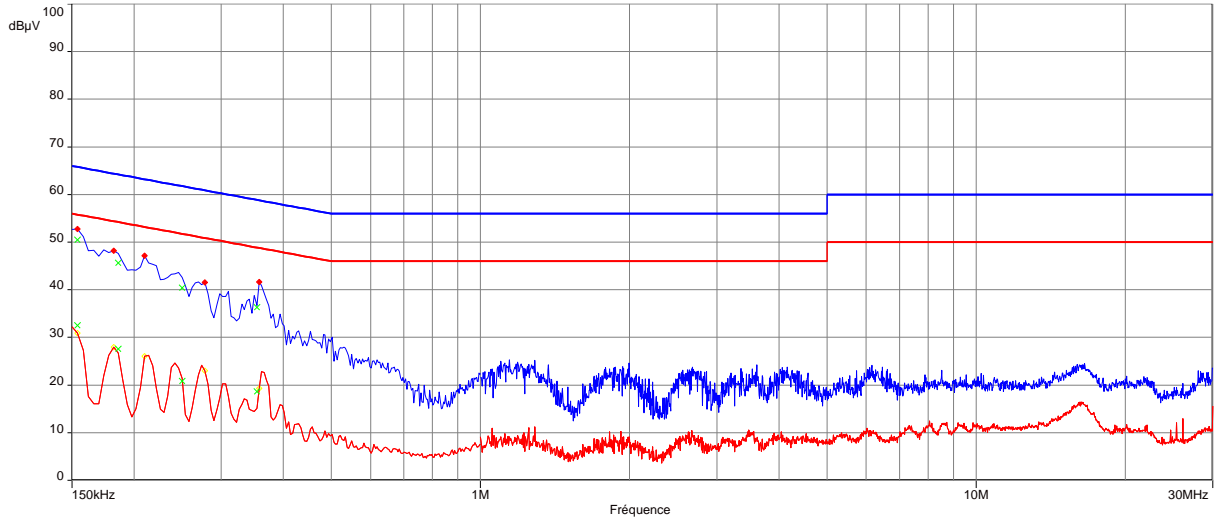

Line Neutral

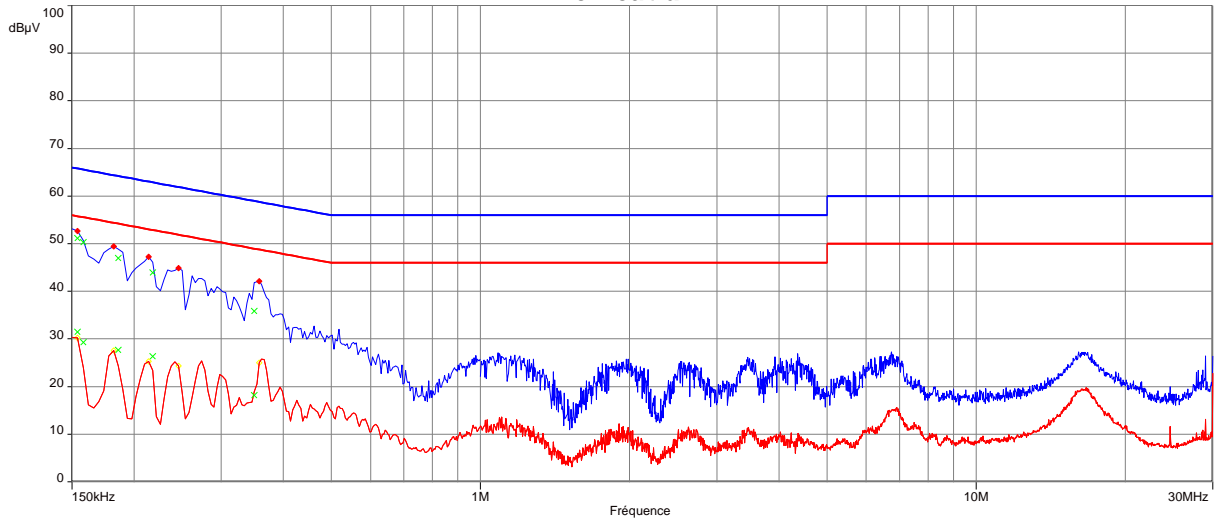

Note : Same result for all transmit modes on all channels.

----: Peak ----: Average

12. 6dB Bandwidth

TEST: 6dB Bandwidth		Verdict
Method: The setup is in an anechoic chamber. The spectrum analyzer is connected to the antenna port of the device under test. A conducted measurement is performed. The tested equipment is set to transmit operation with modulation on its nominal channel		Pass
Laboratory Parameters:	Required prior to the test	During the test
Ambient Temperature	17 to 27°C	21°C ± 2
Relative Humidity	25 to 65 %	42% ± 5
Limits – FCC Part 15.247 (a) / RSS-247 §5.2 (a)		
Frequency (MHz)	Level for Bandwidth	Limit
905.25 / 915.25 / 925.25	6dB below the maximum output power	At least 500kHz
Supplementary information: Test location: SMEE Test date: January 8 th , 2024 by C. KERMICHE. Power supply voltage: 12V DC power supply adapter.		

Tabulated Results for Occupied Bandwidth		
Frequency (MHz)	6dB Bandwidth (kHz)	Result
905.25	624.0	Pass
915.25	625.0	Pass
925.25	625.0	Pass

Graphical representation of 6dB Bandwidth

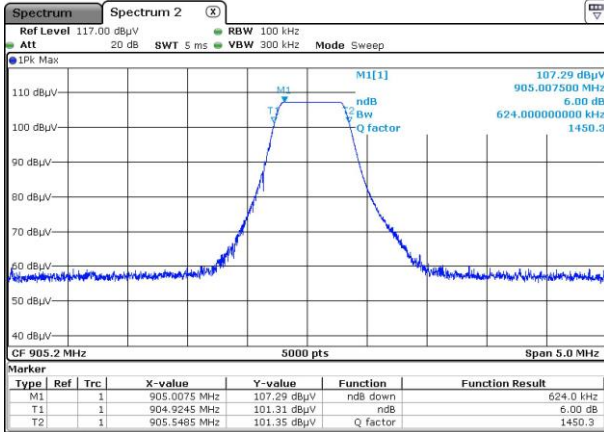

Low

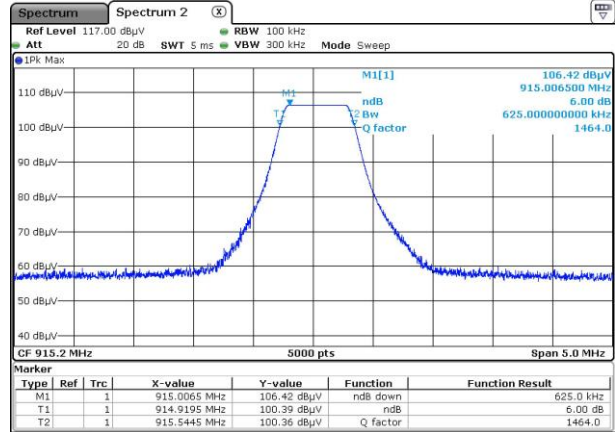

Middle

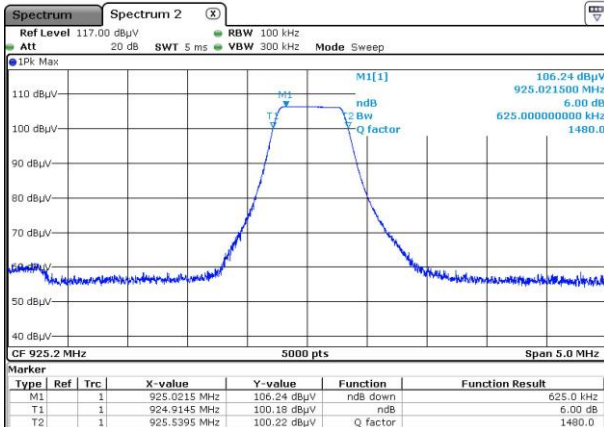

High

RBW : 100kHz
Measurement detector : Peak

13. Fundamental emission output power

TEST: Maximum conducted output power		Verdict
<p><u>Method:</u> The setup is in an anechoic chamber. The spectrum analyzer is connected to the antenna port of the device under test. A conducted measurement is performed. The tested equipment is set to transmit operation with modulation on its nominal channel</p>		Pass
Laboratory Parameters:	Required prior to the test	During the test
Ambient Temperature	17 to 27°C	21°C ± 2
Relative Humidity	25 to 65 %	42% ± 5
Limits – FCC Part 15.247 (b) / RSS-247 §5.4		
Frequency (MHz)	Limits	
	Level	Results
905.25 / 915.25 / 925.25	30 dBm (Conducted)	Pass
	36 dBm (Radiated, EIRP)	Pass
<p>Supplementary information: Test location: SMEE Test date: January 8th, 2024 by C. KERMICHE. Power supply voltage: 12V DC power supply adapter.</p>		

Tabulated Results for Maximum peak output power (Conducted & Radiated measurement)						
FREQ	Conducted power	Antenna Gain	Radiated power E.I.R.P	Conducted Limit	Radiated Limit	Result
(MHz)	(dBm)	(dBi)	(dBm)	(dBm)	(dBm)	
905.25	10.2	5.2	15.4	30.0	36.0	Pass
915.25	9.3	5.2	14.5	30.0	36.0	Pass
925.25	10.4	5.2	15.6	30.0	36.0	Pass
RBW:	1MHz					
Measurement distance:	3m					
Limit:	FCC Part 15.247 / RSS-247					
Measurement detector:	Peak					
RESULT:	PASS					
Note:	EIRP is calculated using the following equation: $\text{EIRP} = \text{Conducted power (dBm)} + \text{Antenna Gain (dBi)}$ Where Antenna gain = 5.2 dBi.					

Graphical representation of Maximum Peak output power (conducted)

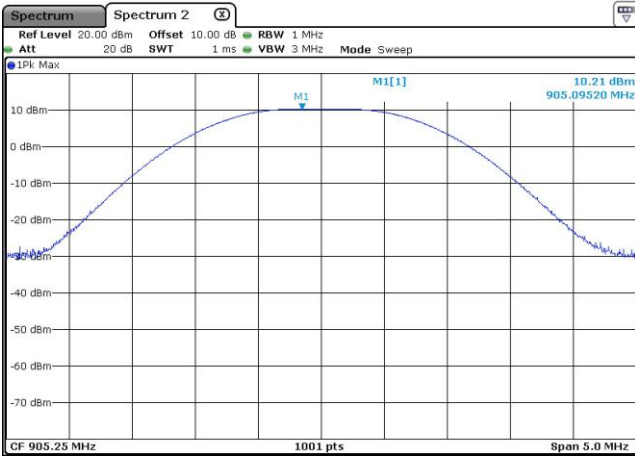

Low

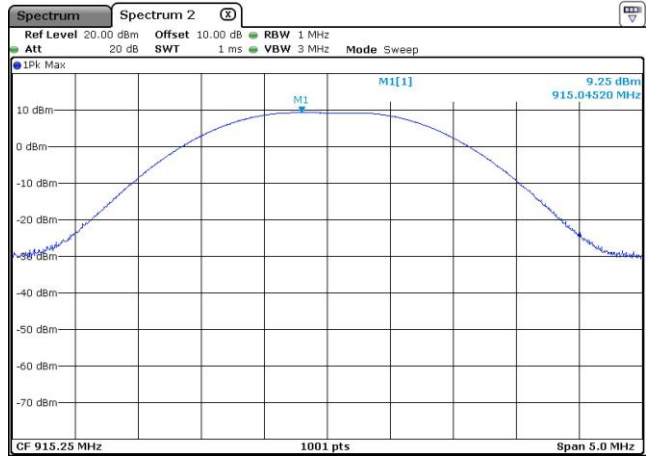

Middle

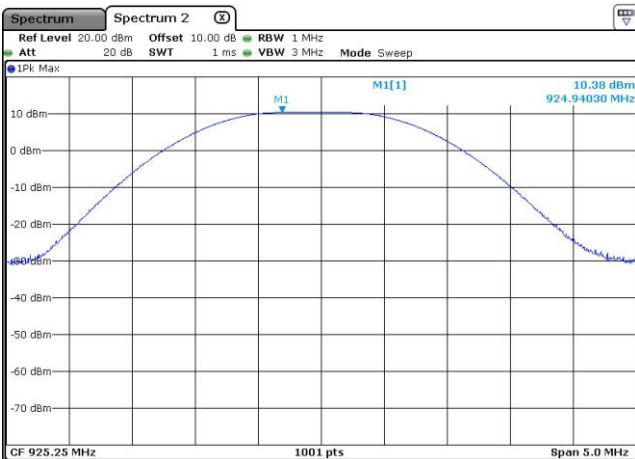

High

14. Maximum Power Spectral Density Level in the fundamental emission

TEST: Maximum Peak Power Spectral Density		Verdict
Method: The setup is in an anechoic chamber. The spectrum analyzer is connected to the antenna port of the device under test. A conducted measurement is performed. The tested equipment is set to transmit operation with modulation on its nominal channel		Pass
Laboratory Parameters:	Required prior to the test	During the test
Ambient Temperature	17 to 27°C	22°C ± 2
Relative Humidity	25 to 65 %	45% ± 5
Limits – FCC Part 15.247 (e) / RSS-247 §5.2 (b)		
Frequency (MHz)	Level	Limit
905.25 / 915.25 / 925.25	8 dBm/3kHz	Pass
Supplementary information: Test location: SMEE Test date: January 8 th , 2024 by C. KERMICHE. Power supply voltage: 12V DC power supply adapter.		

Tabulated Results for Maximum Conducted Power Spectral Density			
Frequency (MHz)	PSD (dBm/3kHz)	Limit	Result
905.25	-2.1	8dBm/3kHz	Pass
915.25	-3.2	8dBm/3kHz	Pass
925.25	-3.7	8dBm/3kHz	Pass
RBW:	3kHz		
Limit:	FCC Part 15.247 / RSS-247		
Final measurement detector:	Peak		
RESULT:	PASS		

Graphical representation of Conducted output power density

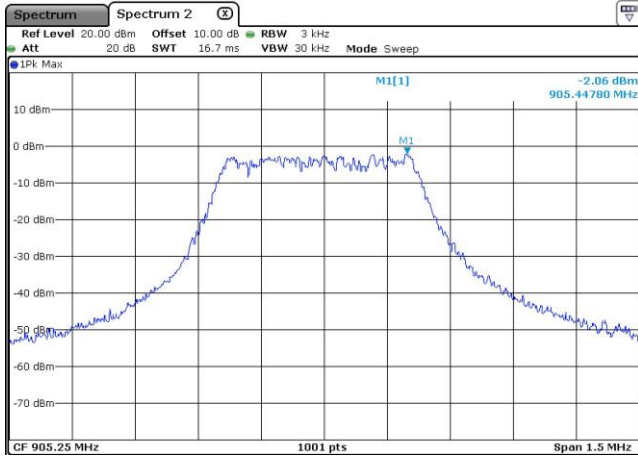

Low

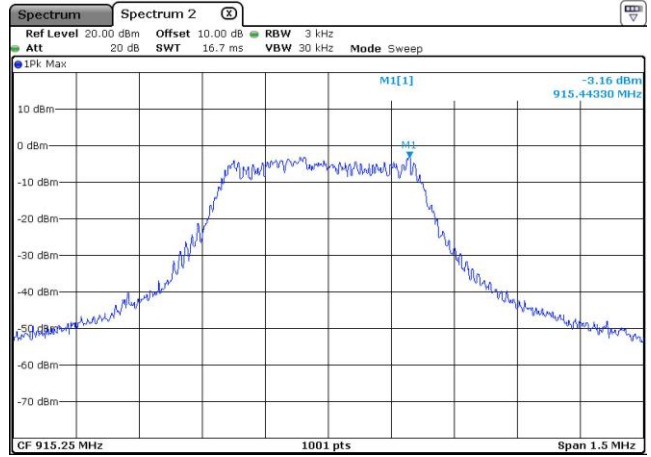

Middle

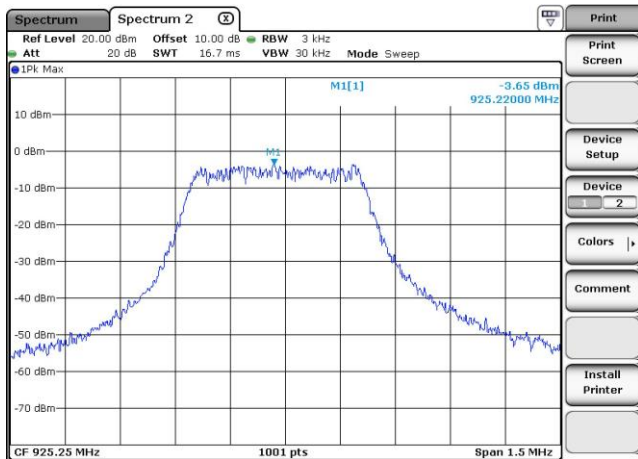

High

15. Unwanted emissions in Non-Restricted Frequency bands (Radiated emissions)

TEST: Unwanted emissions in Non-Restricted Frequency Bands			Verdict
<p>Method: Measurements were made in a 3-meter Semi Anechoic Room (SAR) up to 1GHz and in a 3-meter Full Anechoic environment (SAR with floor absorbers) above 1GHz. The Semi Anechoic Room complies with CISPR16-1-4 / ANSI C63.4 requirements. Preliminary (peak) measurements were performed at an antenna to EUT separation distance of 3 meter. The EUT was rotated 360° about its azimuth with the receive antenna located at various heights in horizontal and vertical polarities. The pre-characterization graphs are obtained in PEAK detection. Final measurements (Peak, Quasi-peak, Average) were then performed by rotating the EUT 360° and adjusting the receive antenna height from 1 to 4 m. All frequencies were investigated in both horizontal and vertical antenna polarity, where applicable. Three orthogonal axis measurements on EUT are performed to obtain the maximum peak field strength.</p>			Pass
Laboratory Parameters:			
	Required prior to the test	During the test	
Ambient Temperature	17 to 27°C	22°C ± 2	
Relative Humidity	25 to 65 %	38% ± 5	
Fully configured sample scanned over the following frequency range	Frequency range on each side of line	Measurement Point	
	30MHz – 10GHz	3 m measurement distance	
Limits – FCC Part 15.247 (d) / RSS-247 § 5.5			
Frequency (MHz)	Limits (dBµV/m)		
	Detector / Analyser RBW	Limit	Results
30 to 10000	Pk / 100kHz	20dB below the maximum Peak level	Pass
<p>Supplementary information: Test location: SMEE Test date: January 4th, 2024 by C. KERMICHE. Power supply voltage: 12V DC power supply adapter.</p>			

Tabulated Results for Peak Output Radiated level	
FREQ (MHz)	Field Strength 3m (dB μ V/m)
905.25	107.9
915.25	107.5
925.25	107.3
RBW:	100kHz
Measurement distance:	3m
Limit:	Ref. level only – For 15.247 (d) / RSS-247 § 5.5
Final measurement detector:	Peak
Note:	(1): Only for identification of limit in non-restricted band Limit is 87.3 dBμV/m Peak for out-of-band frequencies in Non-Restricted bands (with a 100kHz RBW on the spectrum analyser)

Tabulated Results for Unwanted emissions in Non-Restricted bands				
FREQ (MHz)	Field Strength 3m (dB μ V/m)	Limit (dB μ V/m)	Margin (dB μ V/m)	Result (dB μ V/m)
Levels are at least 10 dB below the -20dBc limit See pre-scan graphs in chapter 16.				
RBW:	100kHz			
Measurement distance:	3m			
Limit:	15.247 / RSS-247			
Final measurement detector:	Peak			
RESULT:	PASS			
Note:	3-axis measurement performed for device under test.			

Graphical representation of Band-edge compliance

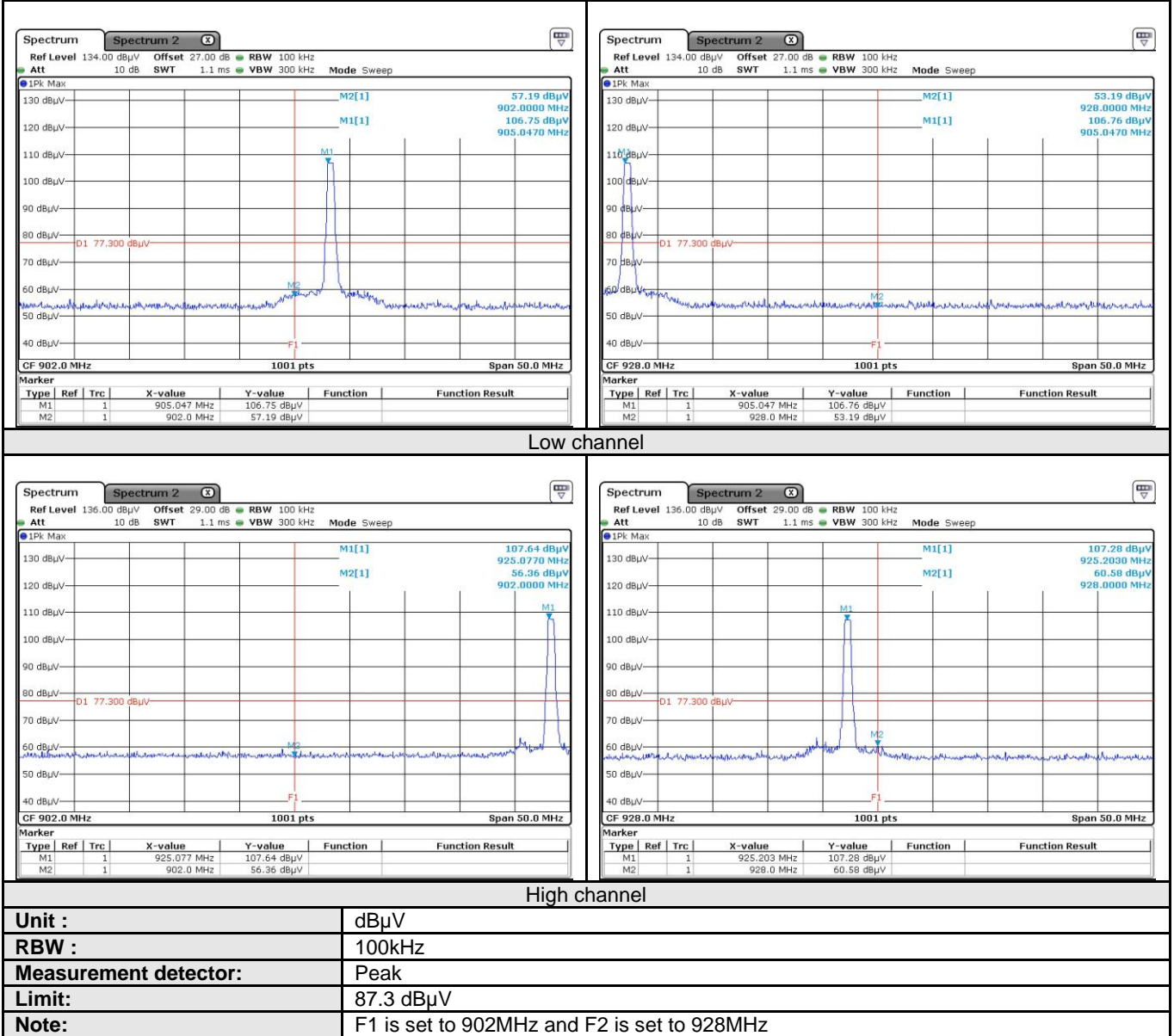

16. Unwanted emissions in Restricted Frequency bands

TEST: Unwanted emissions into Restricted Frequency Bands		Verdict
<p>Method: Measurements were made in a 3-meter Semi Anechoic Room (SAR) for frequency 30MHz to 1GHz and in a 3-meter Full Anechoic environment (SAR with floor absorbers) above 1GHz. The Semi Anechoic Room complies with CISPR16-1-4 / ANSI C63.4 requirements. For frequency 9kHz to 30MHz, measurements are performed on a free-space open area test site at 10m distance.</p> <p>Preliminary (peak) measurements were performed at an antenna to EUT separation distance of 3 meter. The EUT was rotated 360° about its azimuth with the receive antenna located at various heights in horizontal and vertical polarities.</p> <p>Final measurements (Peak, Quasi-peak, Average) were then performed by rotating the EUT 360° and adjusting the receive antenna height from 1 to 4 m. All frequencies were investigated in both horizontal and vertical antenna polarity, where applicable.</p> <p>Three orthogonal axis measurements on EUT are performed to obtain the maximum peak field strength.</p>		Pass
Laboratory Parameters:	Required prior to the test	During the test
Ambient Temperature	17 to 27°C	22°C ± 2
Relative Humidity	25 to 65 %	38% ± 5
Fully configured sample scanned over the following frequency range	Frequency range on each side of line	Measurement Point
	9kHz – 30MHz	10 m measurement distance
	30MHz – 10GHz	3 m measurement distance
Limits – FCC Part 15.205, 15.209 (a), 15.247 (d) / RSS-GEN §8.9, §8.10, RSS-247 §5.5		
Frequency (MHz)	Limits (dBµV/m)	
	Level / Detector / Distance	Results
0.009 to 0.090	107.6 – 87.6 / AV / 10m 127.6 – 107.6 / PK / 10m	Pass
0.090 to 0.110	87.6 – 85.9 / QP / 10m	Pass
0.110 to 0.490	85.7 – 72.9 / AV / 10m 105.7 – 92.9 / PK / 10m	Pass
0.490 to 1.705	52.9 – 42.1 / QP / 10m	Pass
1.705 to 30	48.6 / QP / 10m	Pass
30 to 88	40.0 / QP / 3m	Pass
88 to 216	43.5 / QP / 3m	Pass
216 to 960	46.0 / QP / 3m	Pass
960-1000	54.0 / QP / 3m	Pass
Above 1GHz	54.0 / AV / 3m 74.0 / PK / 3m	Pass
Supplementary information: Test location: SMEE Test date: January 4 th , 2024 by C. KERMICHE. Power supply voltage: 12V DC power supply adapter.		

Tabulated Results for Unwanted emissions (9kHz-490kHz)

FREQ	RF field @ 300m	Limit @ 300m	Detector	Margin	Ant. angle	Table angle	Correc. Fact. (CF)
MHz	dB μ V/m	dB μ V/m	Pk / QP / AV	dB	Degree	Degree	dB
All levels are at least 10dB below applicable limits							
Supplementary information: Frequency list measured has been created with pre-scan results.							
Frequency band investigated:		9kHz-490kHz					
RBW:		200Hz (9kHz-150kHz) 9kHz (150kHz-30MHz)					
Measurement distance:		10m					
Final measurement detector:		Peak / Quasi-Peak / Average					
Limit:		FCC Part 15.209 / RSS-Gen					
Note:		CF: Correction factor = Antenna factor + Cable loss *1: Measure have been done at 10m distance and corrected according to requirements of 15.209.e / RSS-Gen clause 6.5) (M@300m = M@10m-59.1dB) Loop antenna used and rotated about its axis to maximize any emission.					

Tabulated Results for Unwanted emissions (490kHz-30MHz)

FREQ	RF field @ 30m	Limit @ 30m	Detector	Margin	Ant. angle	Table angle	Correc. Fact. (CF)
MHz	dB μ V/m	dB μ V/m	Pk / QP	dB	Degree	Degree	dB
All levels are at least 10dB below applicable limits							
Supplementary information: Frequency list measured has been created with pre-scan results.							
Frequency band investigated:		490kHz-30MHz					
RBW:		9kHz (150kHz-30MHz)					
Measurement distance:		10m					
Final measurement detector:		Quasi-Peak					
Limit:		FCC Part 15.209 / RSS-Gen					
Note:		CF: Correction factor = Antenna factor + Cable loss *1: Measure have been done at 10m distance and corrected according to requirements of 15.209.e / RSS-Gen clause 6.5) (M@30m = M@10m-19.1dB) Loop antenna used and rotated about its axis to maximize any emission.					

Graphical representation of Radiated Disturbance Measurement (Peak detection, Anechoic chamber pre-scan, 9kHz-30MHz / 3m / Parallel & Perpendicular antenna position / Transmit mode)

Parallel

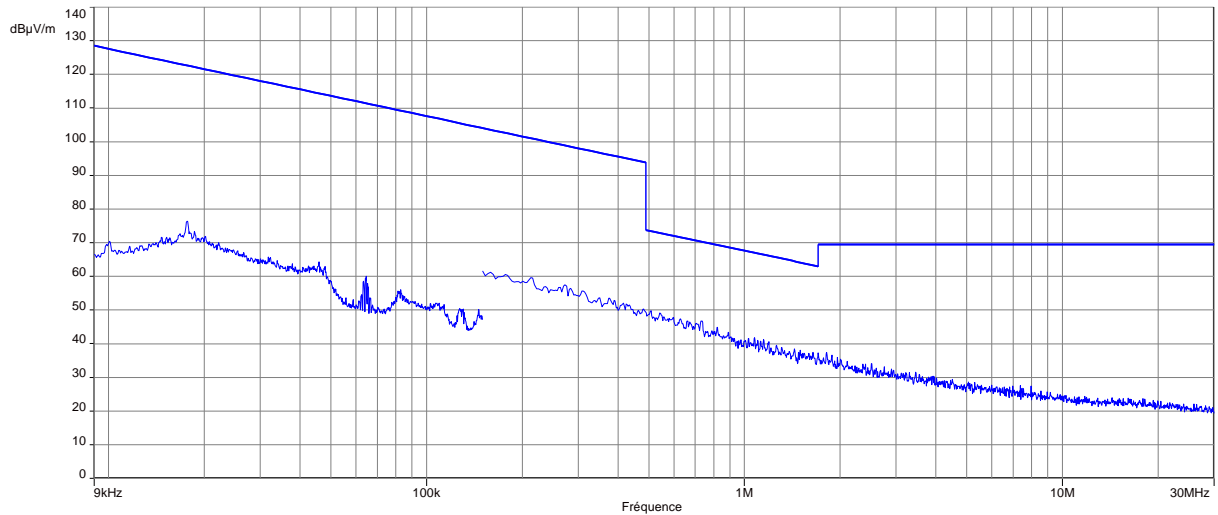

Perpendicular

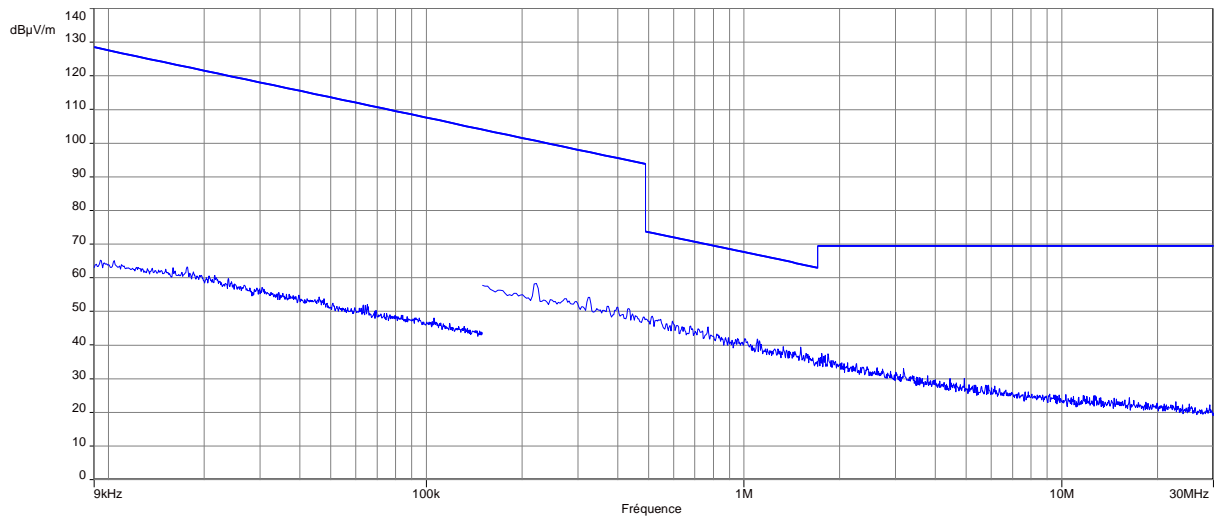

Frequency band investigated:	9kHz-30MHz
Unit :	dBµV/m
RBW :	200Hz (9kHz-150kHz) 9kHz (150kHz-30MHz)
Antenna polarization :	Parallel & Perpendicular to measurement axis.
Measurement detector:	Peak.
Notes:	Pre-scan graph only for identification purpose. Same result for all measured frequencies and power supplies. (Power adapter and PoE)

Graphical representation of Radiated Disturbance Measurement (Peak detection, Full Anechoic Chamber pre-scan, 30MHz-10GHz / 3m / Transmit mode / Worst position)

Powered by supply adapter

Center frequency: 905.25 MHz

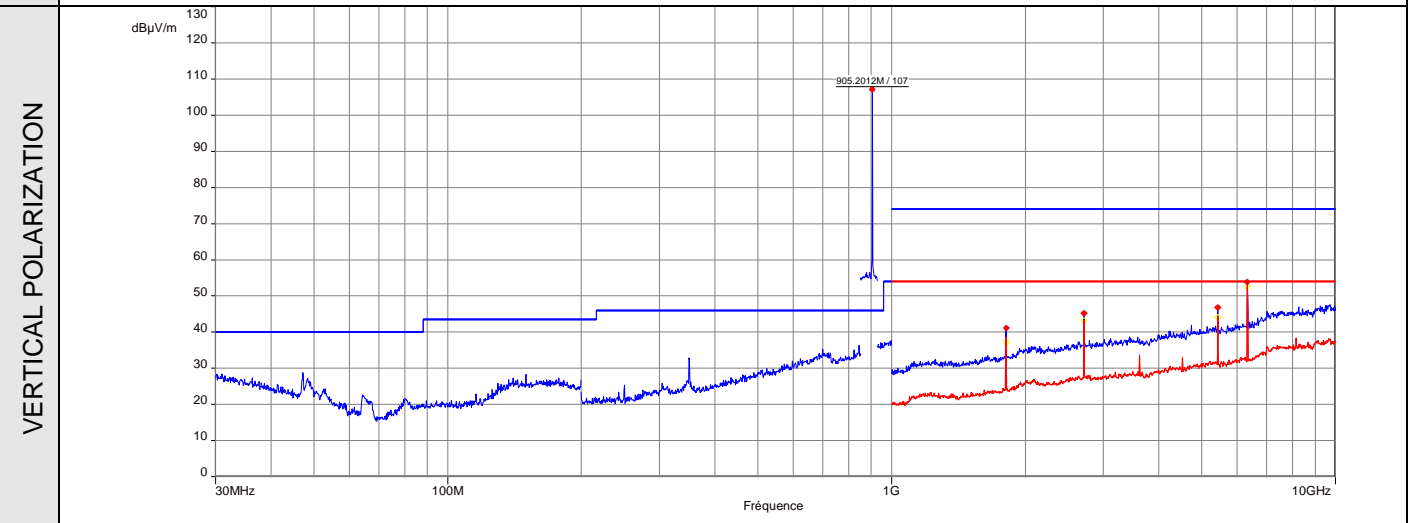
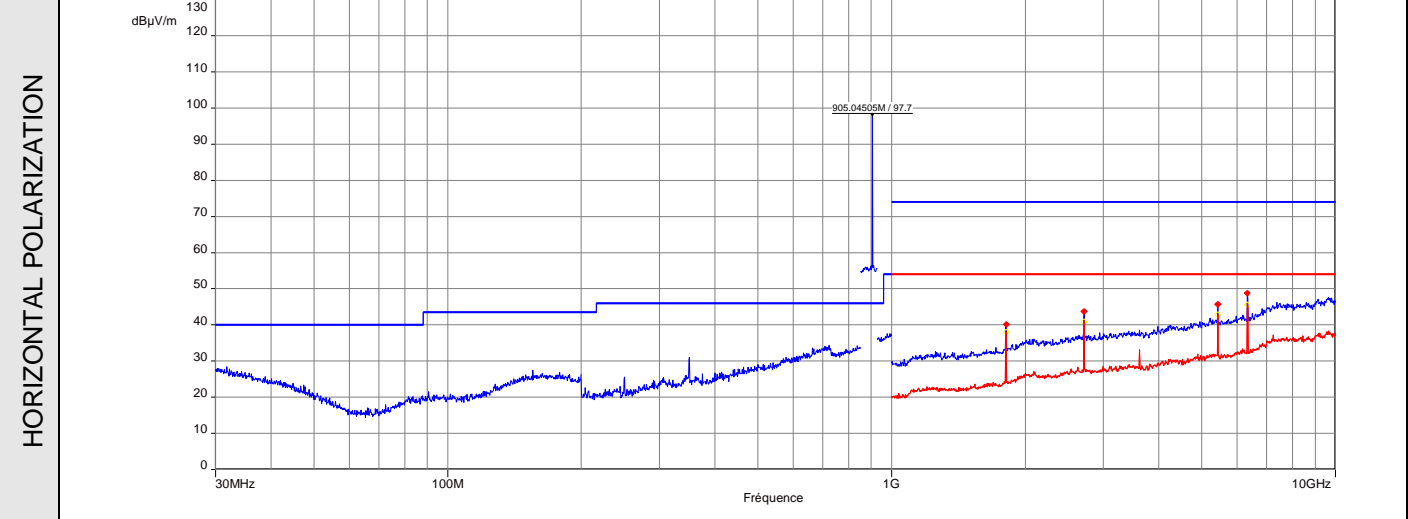

Frequency	Field Strength (PK)	Field Strength (QP or AV)	Limit (PK)	Margin (PK)	Limit (QP or AV)	Margin (QP or AV)	Table angle	Ant height	Result	Detector & Limit	Pol	Note
MHz	dBµV/m	dBµV/m	dBµV/m	dBµV/m	dB	dB	Degree	m				
1810.58783	40.16	-	-	-	-	-	-	-	Pass	PK	H	(2)
2715.77117	44.95	35.30	74.00	-29.05	54.00	-18.70	181.40	1.95	Pass	PK / AVG	H	(1)
5431.26005	47.41	34.21	74.00	-26.59	54.00	-19.79	234.80	1.62	Pass	PK / AVG	H	(1)
6335.47923	48.83	-	-	-	-	-	-	-	Pass	PK	H	(2)
1810.86909	41.2	-	-	-	-	-	-	-	Pass	PK	V	(2)
2715.70035	46.91	38.16	74.00	-27.09	54.00	-15.84	134.30	1.41	Pass	PK / AVG	V	(1)
5431.1246	47.49	34.01	74.00	-26.51	54.00	-19.99	212.00	1.82	Pass	PK / AVG	V	(1)
6337.16679	53.87	-	-	-	-	-	-	-	Pass	PK	V	(2)

Frequency and Limit band: 30Mz-25GHz / FCC 15.209 / RSS-GEN

RBW and Limit detector: Below 1GHz: RBW= 100kHz, Quasi-Peak Limit
Above 1GHz: RBW= 1MHz, Peak and Average Limit

Note: Pre-scan graph only for identification purpose.
(1) Restricted band.
(2) Non-Restricted band (Limit 20dB below the maximum Peak level)

Graphical representation of Radiated Disturbance Measurement (Peak detection, Full Anechoic Chamber pre-scan, 30MHz-10GHz / 3m / Transmit mode / Worst position)

Powered by supply adapter

Center frequency: 915.25 MHz

HORIZONTAL POLARIZATION

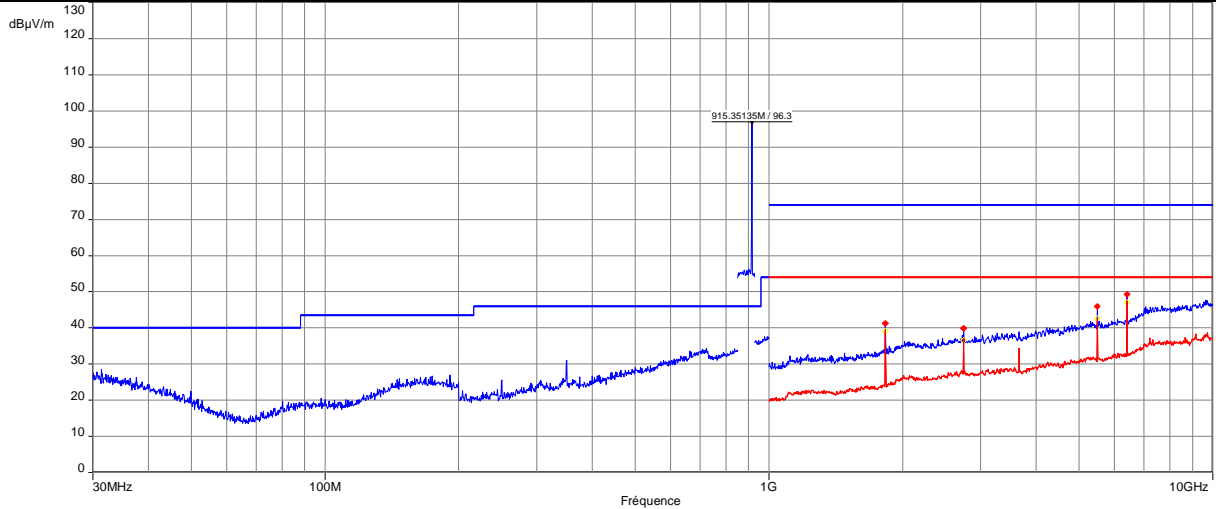

VERTICAL POLARIZATION

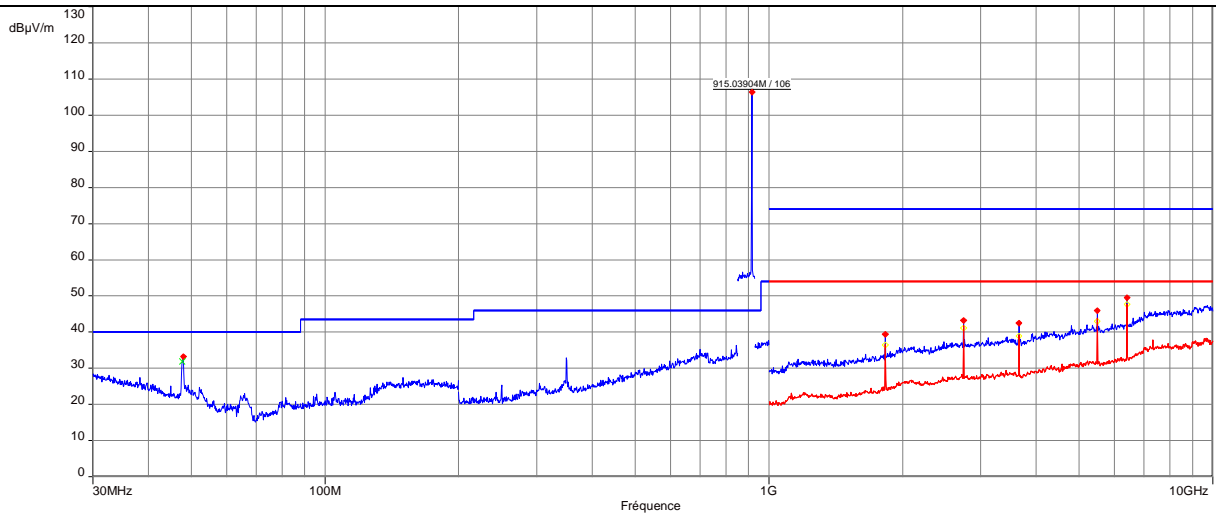

Frequency	Field Strength (PK)	Field Strength (QP or AV)	Limit (PK)	Margin (PK)	Limit (QP or AV)	Margin (QP or AV)	Table angle	Ant height	Result	Detector & Limit	Pol	Note
MHz	dBµV/m	dBµV/m	dBµV/m	dB	dBµV/m	dB	Degree	m				
1830.55721	41.32	-	-	-	-	-	-	-	Pass	PK	H	(2)
2746.28221	41.88	31.14	74.00	-32.12	54.00	-22.86	184.70	1.59	Pass	PK / AVG	H	(1)
5489.9628	47.41	33.99	74.00	-26.59	54.00	-20.01	211.20	1.09	Pass	PK / AVG	H	(1)
6407.48148	49.31	-	-	-	-	-	-	-	Pass	PK	H	(2)
47.703214	31.88	26.47	-	-	40	-13.53	5	1.07	Pass	QP	V	(1)
1830.27595	39.38	-	-	-	-	-	-	-	Pass	PK	V	(2)
2745.31536	45.03	32.52	74.00	-28.97	54.00	-21.48	145.60	1.20	Pass	PK / AVG	V	(1)
3660.27612	43.65	30.48	74.00	-30.35	54.00	-23.52	100.40	1.66	Pass	PK / AVG	V	(1)
5490.67922	48.38	35.41	74.00	-25.62	54.00	-18.59	164.20	1.52	Pass	PK / AVG	V	(1)
6406.07519	49.61	-	-	-	-	-	-	-	Pass	PK	V	(2)

Frequency and Limit band: 30Mz-25GHz / FCC 15.209 / RSS-GEN

RBW and Limit detector: Below 1GHz: RBW= 100kHz, Quasi-Peak Limit
Above 1GHz: RBW= 1MHz, Peak and Average Limit

Note: Pre-scan graph only for identification purpose.
(1) Restricted band.
(2) Non-Restricted band (Limit 20dB below the maximum Peak level)

Graphical representation of Radiated Disturbance Measurement (Peak detection, Full Anechoic Chamber pre-scan, 30MHz-10GHz / 3m / Transmit mode / Worst position)

Powered by supply adapter

Center frequency: 925.25 MHz

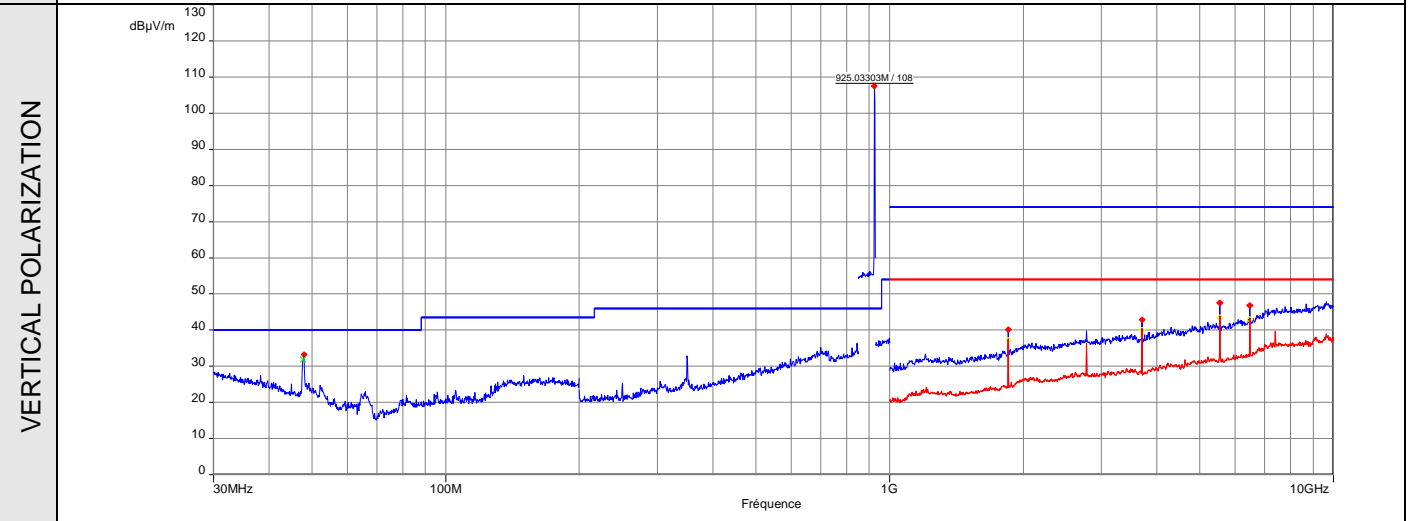
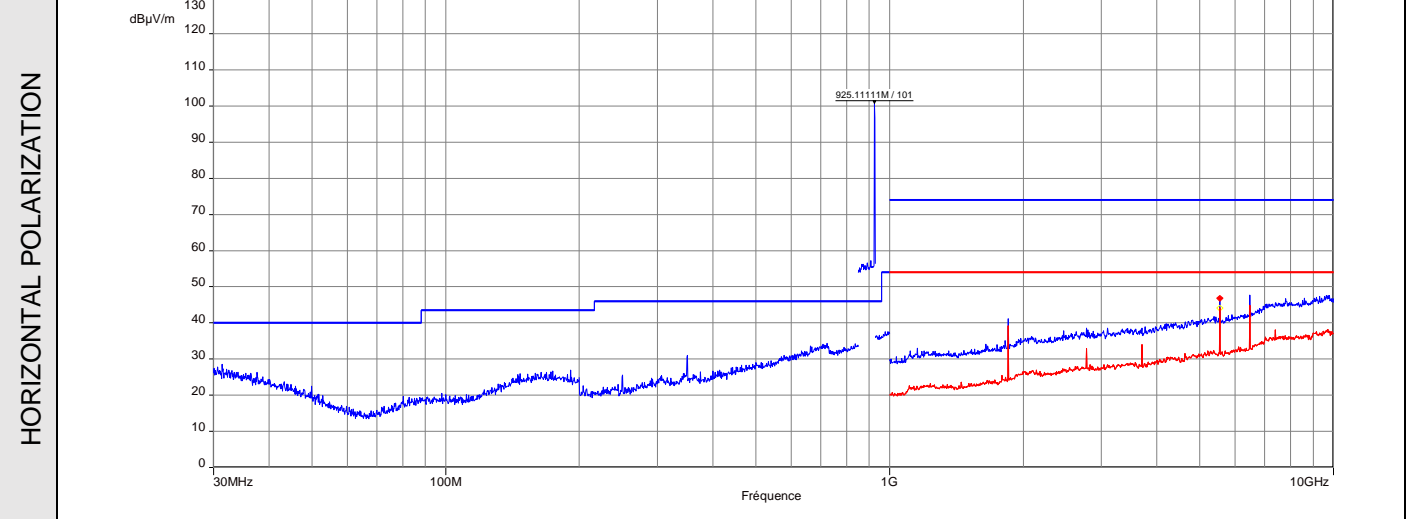

Frequency	Field Strength (PK)	Field Strength (QP or AV)	Limit (PK)	Margin (PK)	Limit (QP or AV)	Margin (QP or AV)	Table angle	Ant height	Result	Detector & Limit	Pol	Note
MHz	dBµV/m	dBµV/m	dBµV/m	dBµV/m	dB	dB	Degree	m				
5552.60992	48.27	32.75	74.00	-25.73	54.00	-21.25	336.80	1.77	Pass	PK / AVG	H	(1)
47.703214	31.88	26.47	-	-	40	-13.53	5	1.07	Pass	QP	V	(1)
1850.24532	40.15	-	-	-	-	-	-	-	Pass	PK	V	(2)
3700.88085	43.12	29.93	74.00	-30.88	54.00	-24.07	97.70	1.37	Pass	PK / AVG	V	(1)
5550.00626	48.60	35.37	74.00	-25.40	54.00	-18.63	105.40	1.58	Pass	PK / AVG	V	(1)
6477.51492	46.82	-	-	-	-	-	-	-	Pass	PK	V	(2)
Frequency and Limit band:			30Mz-25GHz / FCC 15.209 / RSS-GEN									
RBW and Limit detector:			Below 1GHz: RBW= 100kHz, Quasi-Peak Limit Above 1GHz: RBW= 1MHz, Peak and Average Limit									
Note:			Pre-scan graph only for identification purpose. (1) Restricted band. (2) Non-Restricted band (Limit 20dB below the maximum Peak level)									

Graphical representation of Radiated Disturbance Measurement (Peak detection, Full Anechoic Chamber pre-scan, 30MHz-10GHz / 3m / Transmit mode / Worst position)

Worst case for powering by PoE

Center frequency: 915.25 MHz

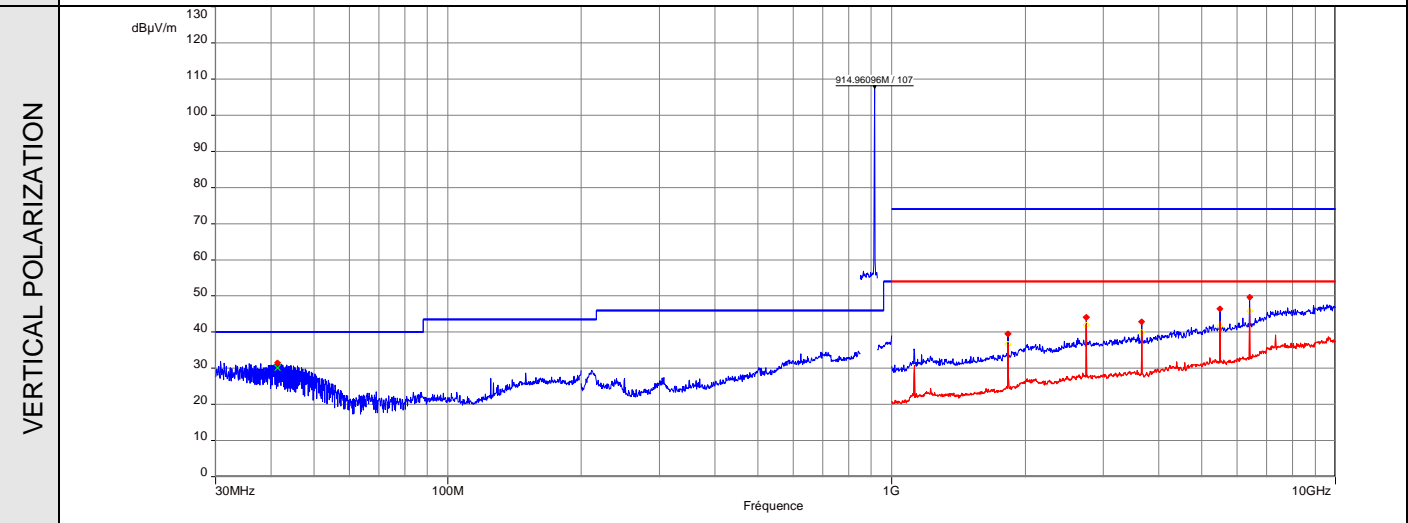
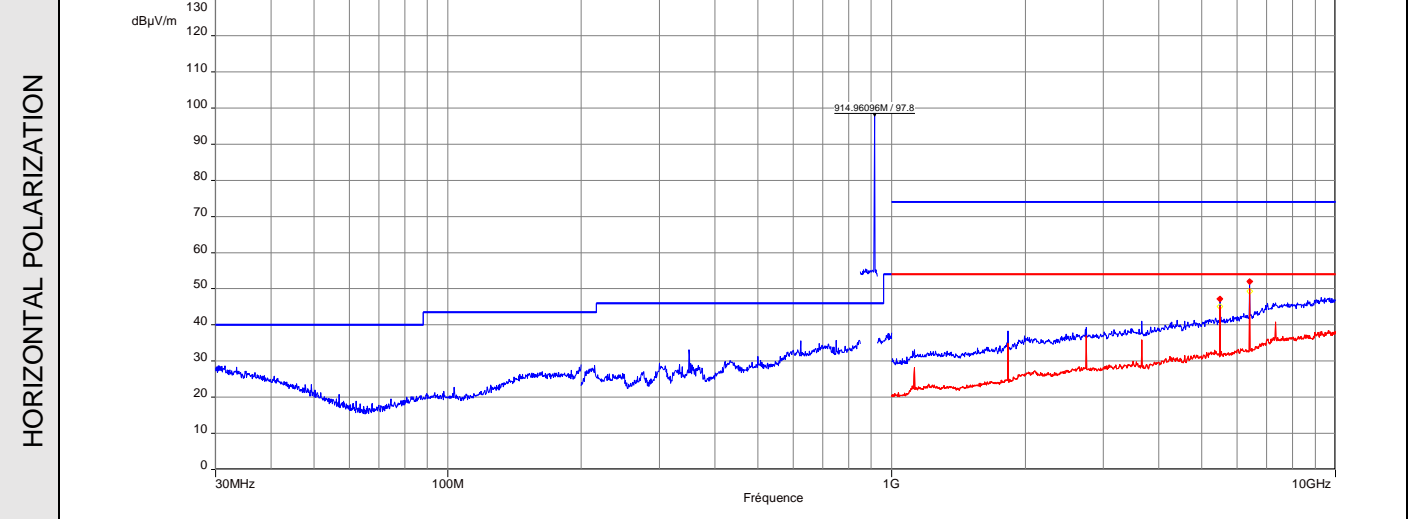

Frequency	Field Strength (PK)	Field Strength (QP or AV)	Limit (PK)	Margin (PK)	Limit (QP or AV)	Margin (QP or AV)	Table angle	Ant height	Result	Detector & Limit	Pol	Note
MHz	dBµV/m	dBµV/m	dBµV/m	dBµV/m	dB	dB	Degree	m				
5492.17966	49.45	35.10	74.00	-24.55	54.00	-18.90	207.10	1.11	Pass	PK / AVG	H	(1)
6408.044001	52.07	-	-	-	-	-	-	-	Pass	PK	H	(2)
41.29637	30.18	28.86	-	-	40.00	-11.14	360.00	1.00	Pass	QK	V	(1)
1829.994687	39.56	-	-	-	-	-	-	-	Pass	PK	V	(2)
2745.07229	44.35	33.02	74.00	-29.65	54.00	-20.98	166.20	1.09	Pass	PK / AVG	V	(1)
3660.81703	44.16	32.91	74.00	-29.84	54.00	-21.09	116.70	2.28	Pass	PK / AVG	V	(1)
5492.11044	46.74	33.36	74.00	-27.26	54.00	-20.64	96.50	1.44	Pass	PK / AVG	V	(1)
6406.918966	49.66	-	-	-	-	-	-	-	Pass	PK	V	(2)

Frequency and Limit band: 30Mz-25GHz / FCC 15.209 / RSS-GEN

RBW and Limit detector: Below 1GHz: RBW= 100kHz, Quasi-Peak Limit
Above 1GHz: RBW= 1MHz, Peak and Average Limit

Note: Pre-scan graph only for identification purpose.
(1) Restricted band.
(2) Non-Restricted band (Limit 20dB below the maximum Peak level)

17. Occupied bandwidth (99%)

TEST: Occupied bandwidth (99%) / RSS-GEN		Verdict
Method: The setup is in an anechoic chamber. The spectrum analyzer is connected to the antenna port of the device under test. A conducted measurement is performed. The tested equipment is set to transmit operation with modulation on its nominal channel		Pass
Laboratory Parameters:	Required prior to the test	During the test
Ambient Temperature	17 to 27°C	21°C ± 2
Relative Humidity	25 to 65 %	42% ± 5
Supplementary information: Test location: SMEE Test date: January 8 th , 2024 by C. KERMICHE. Power supply voltage: 12V DC power supply adapter.		

Tabulated Results for Occupied Bandwidth	
Frequency (MHz)	99% Occupied Bandwidth (kHz)
905.25	504.5
915.25	506.5
925.25	506.0

Graphical representation of Occupied Bandwidth

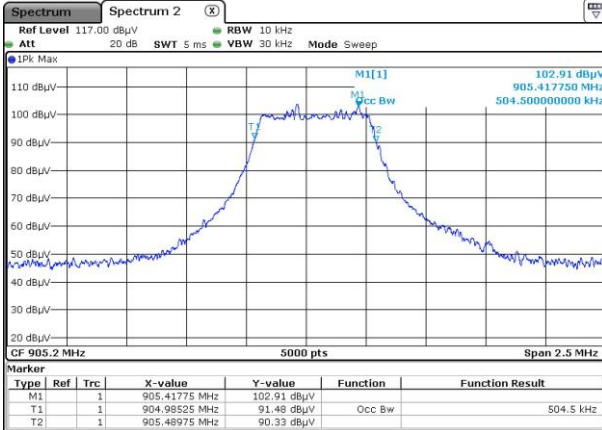

Low

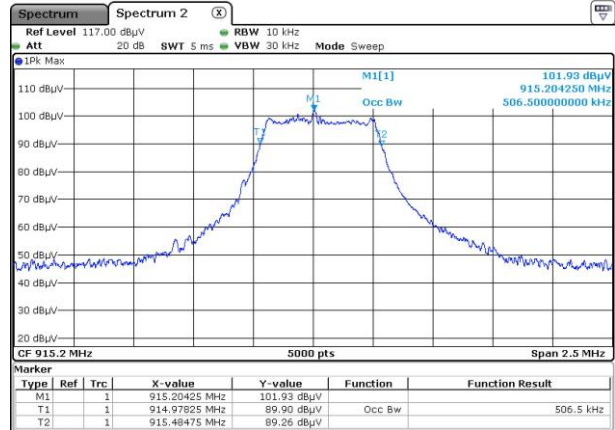

Middle

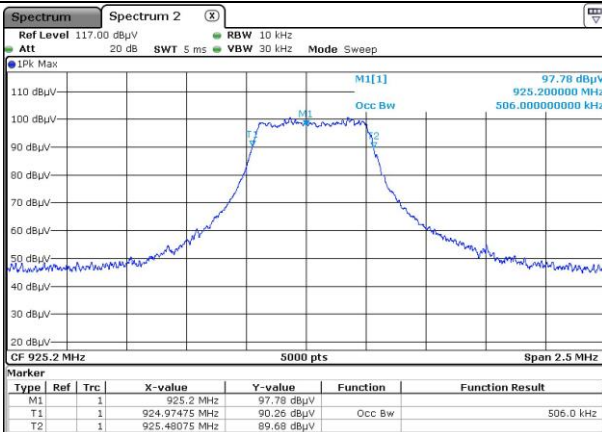

High

END OF TEST REPORT.