



Test report

REP021588-1R1TRFEMC

Date of issue: January 12, 2024

Applicant:

Modular Medical, Inc.

Product:

Insulin Delivery System

Model:

MODD1.1

Variant(s):

N/A

Specifications:

- ◆ 2D Antenna Pattern and Peak Gain

Lab and test locations

Company name	Nemko USA Inc.
Address	2210 Faraday Ave, Suite 150
City	Carlsbad
State	California
Postal code	92008
Country	USA
Telephone	+1 760 444 3500
Website	www.nemko.com
FCC Site Number	Test Firm Registration Number: 392943; Designation Number: US5058
ISED Test Site	2040B-3
Tested by	Chenhao Ma, Wireless Test Technician
Reviewed by	James Cunningham, EMC/WL Manager
Review date	January 12, 2024
Reviewer signature	

Limits of responsibility

Note that the results contained in this report relate only to the items tested and were obtained in the period between the date of initial receipt of samples and the date of issue of the report.

This test report has been completed in accordance with the requirements of ISO/IEC 17025.

Copyright notification

Nemko USA Inc. authorizes the applicant to reproduce this report provided it is reproduced in its entirety and for use by the company's employees only. Any use which a third party makes of this report, or any reliance on or decisions to be made based on it, are the responsibility of such third parties.

Nemko USA Inc. accepts no responsibility for damages, if any, suffered by any third party as a result of decisions made or actions based on this report.

© Nemko USA Inc.

Table of Contents

Table of Contents	3
Section 1 Report summary	4
1.1 Test specifications	4
1.2 Exclusions	4
1.3 Statement of compliance.....	4
1.4 Test report revision history.....	4
Section 2 Summary of test results	5
2.1 Sample information	5
2.2 Testing period.....	5
2.3 Test results	5
Section 3 Equipment (antenna) under test (EUT) details	6
3.1 Disclaimer	6
3.2 Applicant.....	6
3.3 Manufacturer.....	6
3.4 EUT information	6
3.5 Antenna information	6
3.6 EUT setup details	7
Section 4 Engineering considerations	8
4.1 Modifications incorporated in the EUT.....	8
4.2 Technical judgement	8
4.3 Deviations from laboratory test procedures.....	8
Section 5 Test conditions	9
5.1 Atmospheric conditions.....	9
5.2 Power supply range	9
Section 6 Measurement uncertainty	10
6.1 Uncertainty of measurement	10
Section 7 Testing data	11
7.1 2D antenna pattern and peak gain	11

Section 1 Report summary

1.1 Test specifications

None 2D antenna pattern and peak gain

1.2 Exclusions

None.

1.3 Statement of compliance

See "Section 2 Summary of test results" for full details.

1.4 Test report revision history

Table 1.4-1: Test report revision history

Revision #	Issue Date	Details of changes made to test report
REP021588-1TRFEMC	January 4, 2024	Original report issued
REP021588-1R1TRFEMC	January 11, 2024	Updated EUT information

Section 2 Summary of test results

2.1 Sample information

Receipt date	22-Dec-23
Nemko sample ID number	REP021588

2.2 Testing period

Test start date	22-Dec-23
Test end date	22-Dec-23

2.3 Test results

Table 2.3-1: Summary of results

Test description	Verdict
2D antenna pattern	Tested
Peak gain	Tested

Section 3 Equipment (antenna) under test (EUT) details

3.1 Disclaimer

This section contains information provided by the applicant and has been utilized to support the test plan. Inaccurate information provided by the applicant can affect the validity of the results within this test report. Nemko accepts no responsibility for the information contained within this section and the impact it may have on the test plan and resulting measurements.

3.2 Applicant

Company name	Modular Medical, Inc.
Address	10740 Thornmint Road
City	San Diego
State	CA
Postal/Zip code	92127
Country	United States

3.3 Manufacturer

Company name	Modular Medical, Inc.
Address	10740 Thornmint Road
City	San Diego
State	CA
Postal/Zip code	92127
Country	United States

3.4 EUT information

Product name	Insulin Delivery System
Model	MODD1.1
Variant(s)	N/A
Serial number	2341-0357
Part number	MTL-41 (PCBA); MTL-122 (antenna)
Power requirements	CR2032 coin cell power device at 3VDC Nominal
Description/theory of operation	The MODD1.1 Insulin Delivery System is an ambulatory Infusion Pump with a single button. The pump is powered by a single CR2032 battery (a permanent feature of the Insulin Cartridge) and uses a rotating camshaft to drive pistons that extract a small volume of fluid from the reservoir each rotation and inject that fluid through tubing into the patient subcutaneously. A BLE connection to a compatible smartphone allows the user to configure basal insulin delivery schedules, and view pertinent device information via the MMI App. The pump assembly is attached to the user via an adhesive pad.
Operational frequencies	BLE 2.4 GHz, RFID 13.56 MHz, 32 MHz crystal
Software details	MTL-35 MODD1.1 Controller Software for Primary Processor – v1.1.3 MTL-96 MODD1.1 Software for Secondary Processor – v1.1.3 SW-2 Pump Fixture Controller – v1.4.1

3.5 Antenna information

Part number	MTL-122
Description	RF TRACE ANT 2.4GHz 50 OHM
Manufacturer	Modular Medical Inc

3.6 EUT setup details

Table 3.6-1: EUT sub assemblies

Description	Brand name	Model/Part number	Serial number	Rev.
EUT				

Table 3.6-2: EUT interface ports

Description	Qty.
SMA (temporary connector for RF signal injection into antenna)	1

Table 3.6-3: Support equipment

Description	Brand name	Model/Part number	Serial number	Rev.
None				

Table 3.6-4: Inter-connection cables

Cable description	From	To	Length (m)
None			

Section 4 Engineering considerations

4.1 Modifications incorporated in the EUT

None.

4.2 Technical judgement

None.

4.3 Deviations from laboratory test procedures

None.

Section 5 Test conditions

5.1 Atmospheric conditions

Temperature	15–30 °C
Relative humidity	20–75 %
Air pressure	86–106 kPa

When it is impracticable to carry out tests under these conditions, a note to this effect stating the ambient temperature and relative humidity during the tests shall be recorded and stated.

5.2 Power supply range

The normal test voltage for equipment to be connected to the mains shall be the nominal mains voltage. For the purpose of the present document, the nominal voltage shall be the declared voltage, or any of the declared voltages $\pm 5\%$, for which the equipment was designed.

Section 6 Measurement uncertainty

6.1 Uncertainty of measurement

Nemko USA Inc. has calculated measurement uncertainty and is documented in EMC/MUC/001 “Uncertainty in EMC measurements.” Measurement uncertainty was calculated using the methods described in CISPR 16-4-2 Specification for radio disturbance and immunity measuring apparatus and methods – Part 4-2: Uncertainties, statistics, and limit modelling – Measurement instrumentation uncertainty. The expression of Uncertainty in EMC testing. Measurement uncertainty calculations assume a coverage factor of K=2 with 95% certainty.

Table 6.1-1: Measurement uncertainty calculations

Measurement		U_{cispr} dB	U_{lab} dB
Conducted disturbance at AC mains and other port power using a V-AMN	9 kHz to 150 kHz	3.8	2.9
	150 kHz to 30 MHz	3.4	2.3
Conducted disturbance at telecommunication port using AAN	150 kHz to 30 MHz	5.0	4.3
Conducted disturbance at telecommunication port using CVP	150 kHz to 30 MHz	3.9	2.9
Conducted disturbance at telecommunication port using CP	150 kHz to 30 MHz	2.9	1.4
Conducted disturbance at telecommunication port using CP and CVP	150 kHz to 30 MHz	4.0	3.1
Radiated disturbance (electric field strength in a SAC)	30 MHz to 1 GHz	6.3	5.5
Radiated disturbance (electric field strength in a FAR)	1 GHz to 6 GHz	5.2	4.7
Radiated disturbance (electric field strength in a FAR)	6 GHz to 18 GHz	5.5	5.0

- Notes: Compliance assessment:
- If U_{lab} is less than or equal to U_{cispr} then:
- compliance is deemed to occur if no measured disturbance level exceeds the disturbance limit;
 - non-compliance is deemed to occur if any measured disturbance level exceeds the disturbance limit
- If U_{lab} is greater than U_{cispr} then:
- compliance is deemed to occur if no measured disturbance level, increased by $(U_{lab} - U_{cispr})$, exceeds the disturbance limit;
 - non-compliance is deemed to occur if any measured disturbance level, increased by $(U_{lab} - U_{cispr})$, exceeds the disturbance limit

V-AMN: V type artificial mains network
 AAN: Asymmetric artificial network
 CP: Current probe
 CVP: Capacitive voltage probe
 SAC: Semi-anechoic chamber
 FAR: Fully anechoic room

Section 7 Testing data

7.1 2D antenna pattern and peak gain

7.1.1 References and limits

- FCC 47 CFR Part 15, Subpart B: §15.203

7.1.2 Test summary

Verdict	Pass		
Test date	December 22, 2023	Temperature	18 °C
Test engineer	Chenhao Ma, Wireless Test Technician	Air pressure	1005 mbar
Test location	<input type="checkbox"/> 10m semi anechoic chamber <input checked="" type="checkbox"/> 3m semi anechoic chamber <input type="checkbox"/> Other:	Relative humidity	55 %

7.1.3 Notes

Measurements were performed with the antenna under test oriented in 2 orthogonal planes with the measurement antenna oriented in both horizontal and vertical polarizations. For each configuration, the antenna under test was rotated around the vertical axis by 360 degrees so as to capture the antenna gain from all possible orientations / polarizations.

7.1.4 Setup details

Measurements were performed in a 3m semi-anechoic chamber and consisted of 2 steps.

Step 1: Reference Measurement:

A reference antenna is connected to an RF signal generator via a ferrite-loaded cable and 6 dB attenuator. The reference antenna is then placed at the center of the anechoic chamber turntable at a height of approximately 1.5 m. The RF signal generator is then configured to generate a 0 dBm unmodulated signal at the frequency(-ies) under test. The polarization of the receive antenna is adjusted to match the polarization of the transmit antenna and the turntable angle and receive antenna height are adjusted to maximize the received signal level at the measurement receiver.

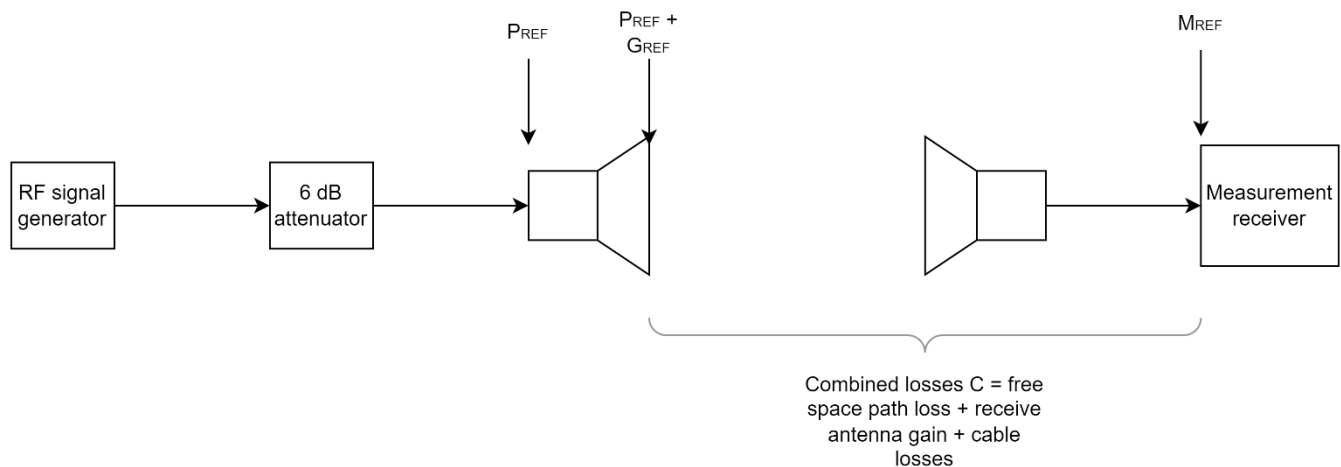

The signal level at the measurement receiver, M_{REF} , is recorded for each of the frequencies under test. Given that the transmit antenna is calibrated with a known gain G_{REF} , the following expression holds true:

$$M_{REF} = P_{REF} + G_{REF} + C \quad \text{Equation [1]}$$

Step 2: Antenna Under Test Measurement

For this step, the reference antenna is replaced with the antenna under test. Again, the RF signal generator is set to 0 dBm output at the frequency(-ies) under test. The received signal level at the measurement receiver is recorded as the antenna under test is rotated 360 degrees in 5 degree steps. The receive antenna is then changed to the opposite polarization and the received signal level at the measurement receiver is recorded again as the turntable is rotated 360 degrees in 5 degree steps.

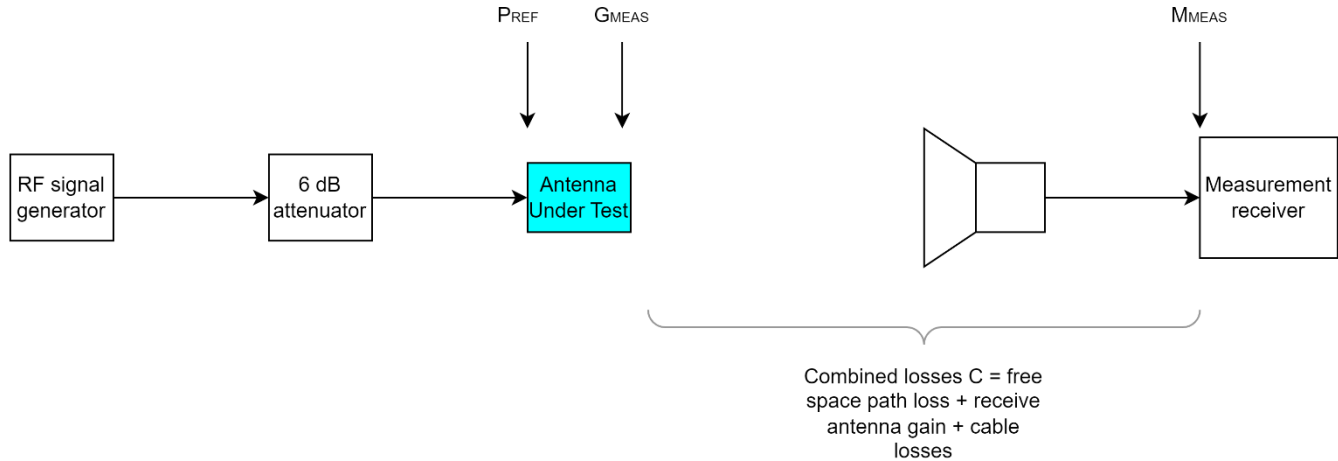

The peak received signal level at the measurement receiver is identified and noted as M_{MEAS} .

As before, the following holds true:

$$M_{MEAS} = P_{REF} + G_{MEAS} + C \quad \text{Equation [2]}$$

G_{MEAS} is the peak gain of the antenna under test and is the value of interest.

Re-arranging Equation [2] in terms of G_{MEAS} gives:

$$G_{MEAS} = M_{MEAS} - P_{REF} - C \quad \text{Equation [3]}$$

And re-arranging Equation [1] in terms of P_{REF} gives:

$$P_{REF} = M_{REF} - G_{REF} - C \quad \text{Equation [4]}$$

Substituting P_{REF} in Equation [3] with Equation [4] gives:

$$\begin{aligned} G_{MEAS} &= M_{MEAS} - (M_{REF} - G_{REF} - C) - C \\ G_{MEAS} &= M_{MEAS} - M_{REF} + G_{REF} + C - C \end{aligned}$$

$$G_{MEAS} = M_{MEAS} - M_{REF} + G_{REF} \quad \text{Equation [5]}$$

Where:

- G_{MEAS} = peak gain of antenna under test in dBi
- M_{MEAS} = measured received signal level with antenna under test
- M_{REF} = measured received signal level with calibrated reference antenna
- G_{REF} = gain of reference antenna in dBi

Section 7

Testing data

Test name

2D antenna pattern and peak gain

Specification(s)

FCC Part 15 Subpart B and ICES-003 Issue 7



Table 7.1-1: 2D antenna pattern and peak gain equipment list

Equipment	Manufacturer	Model no.	Asset no.	Cal cycle	Next cal.
Antenna, Horn	EMCO	3115	1033	2 years	2-Nov-2024
EMI Test Receiver	Rohde & Schwarz	ESU40	E1121	1 year	23-Aug-2024
Signal Generator	Rohde & Schwarz	SMB100A	E1128	3 years	23-Dec-2024
DRH Horn (medium)	ETS Lindgren	3117=PA	E1160	2 years	13-Feb-2024

Notes: N/A – not applicable
 NCR – no calibration required
 VOI – verify on use

Table 7.1-2: 2D antenna pattern and peak gain test software details

Manufacturer of Software	Details
Rohde & Schwarz	EMC 32 V10.60.15

Notes: None

7.1.5 Test data

Table 7.1-3: 2D antenna pattern and peak gain results

Frequency (MHz)	Peak Gain (dBi)
2402 MHz	-0.53
2440 MHz	-1.67
2480 MHz	-1.50

Sample calculation:

Frequency: 2402 MHz
 M_{MEAS} : -35.49 dBm
 M_{REF} : -27.38 dBm
 G_{REF} : 9.58 dBi

$$G_{MEAS} = M_{MEAS} - M_{REF} + G_{REF}$$

$$= (-35.49) - (-27.38) + (9.58)$$

$$= -0.53 \text{ dBi}$$

Note: Plots below show 2D pattern with relative scale in dB.

Azimuth Chart: Vertical

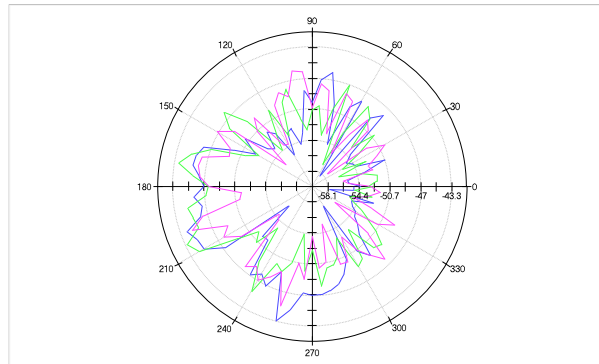

— Frequency 2402.000 MHz [dB]
 — Frequency 2440.000 MHz [dB]
 — Frequency 2480.000 MHz [dB]

Azimuth Chart: Horizontal

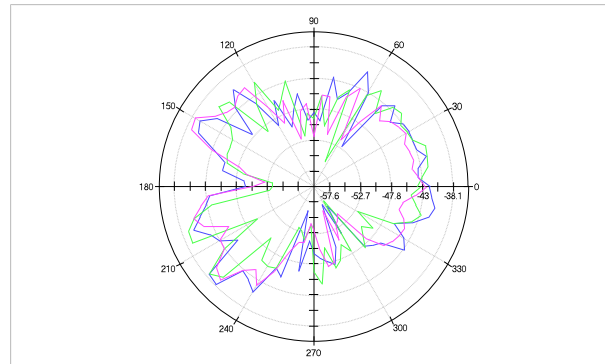

— Frequency 2402.000 MHz [dB]
 — Frequency 2440.000 MHz [dB]
 — Frequency 2480.000 MHz [dB]

Figure 7.1-1: 2D antenna pattern, EUT flat, vertical and horizontal receive polarization respectively

Section 7

Test name

Specification(s)

Testing data

2D antenna pattern and peak gain

FCC Part 15 Subpart B and ICES-003 Issue 7



Azimuth Chart: Vertical

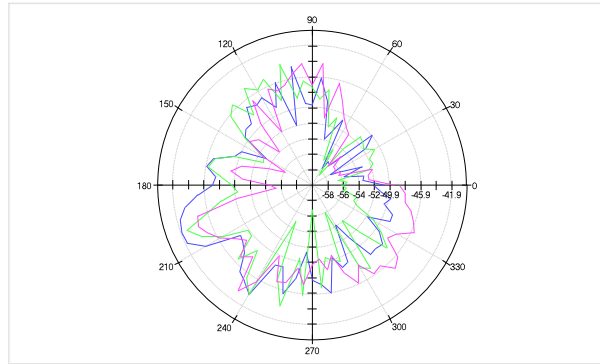

— Frequency 2402.000 MHz [dB]
— Frequency 2440.000 MHz [dB]
— Frequency 2480.000 MHz [dB]

Azimuth Chart: Horizontal

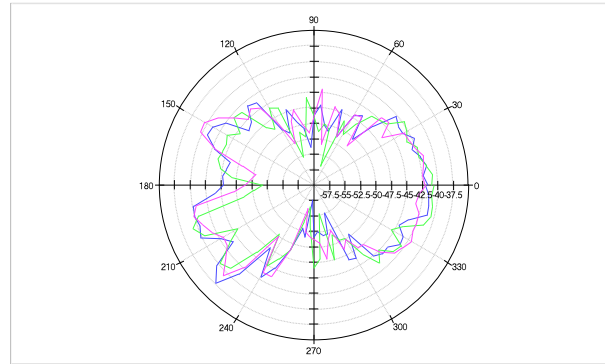

— Frequency 2402.000 MHz [dB]
— Frequency 2440.000 MHz [dB]
— Frequency 2480.000 MHz [dB]

Figure 7.1-2: 2D antenna pattern, EUT horizontal, vertical and horizontal receive polarization respectively

End of test report