

TEST REPORT

Applicant Name: RADIOSHACK WORLDWIDE CORP.
Address: Edificio AFRA | Ave. Samuel Lewis y Calle 54 | Ciudad de Panamá | Apdo. Postal / P.O. Box 0816-01085, Panamá 5, República de Panamá
Report Number: SZGMA231215-75845E-RF-00A
FCC ID: 2BDUR-4304328

Test Standard (s)

FCC PART 15D

Sample Description

Product Type: TELEPHONE
Model No.: 4304328
Multiple Model(s) No.: GCE8108L
Trade Mark: radioshack
Date Received: 2024/01/19
Report Date: 2024/01/31

Test Result:	Pass▲
--------------	-------

▲ In the configuration tested, the EUT complied with the standards above.

Prepared and Checked By:

Mike Xiao

Mike Xiao
RF Engineer

Approved By:

Jimmy Xiao

Jimmy Xiao
RF Supervisor

Note: The information marked # is provided by the applicant, the laboratory is not responsible for its authenticity and this information can affect the validity of the result in the test report. Customer model name, addresses, names, trademarks etc. are included.

This report cannot be reproduced except in full, without prior written approval of the Company. Unless otherwise stated the results shown in this test report refer only to the sample(s) tested. This report is valid only with a valid digital signature. The digital signature may be available only under the Adobe software above version 7.0.

This report must not be used by the customer to claim product certification, approval, or endorsement by NVLAP or any agency of the U.S. Government.

This report may contain data that are not covered by the NVLAP accreditation and are marked with an asterisk "▼".

Bay Area Compliance Laboratories Corp. (Shenzhen)

5F(B-West), 6F, 7F, the 3rd Phase of Wan Li Industrial Building D, Shihua Rd, FuTian Free Trade Zone, Shenzhen, China

Tel: +86-755-33320018 Fax: +86-755-33320008 www.baclcorp.com.cn

TABLE OF CONTENTS

DOCUMENT REVISION HISTORY	4
GENERAL INFORMATION.....	5
PRODUCT DESCRIPTION FOR EQUIPMENT UNDER TEST (EUT).....	5
OBJECTIVE	5
TEST METHODOLOGY	5
MEASUREMENT UNCERTAINTY.....	6
TEST FACILITY	6
SYSTEM TEST CONFIGURATION.....	7
DESCRIPTION OF TEST CONFIGURATION	7
EQUIPMENT MODIFICATIONS	7
LOCAL SUPPORT EQUIPMENT LIST AND DETAILS	7
EXTERNAL I/O CABLE.....	7
BLOCK DIAGRAM OF TEST SETUP	7
SUMMARY OF TEST RESULTS	9
TEST EQUIPMENT LIST	10
FCC §1.1307(B) & §2.1091 – RF EXPOSURE EVALUATION.....	11
APPLICABLE STANDARD	11
RESULT	11
§ 15.317, § 15.203 ANTENNA REQUIREMENT	12
APPLICABLE STANDARD	12
ANTENNA CONNECTOR CONSTRUCTION	12
FCC§15.315 & §15.207 - CONDUCTED EMISSIONS.....	13
APPLICABLE STANDARD	13
EUT SETUP	13
EMI TEST RECEIVER SETUP.....	13
TEST PROCEDURE	14
FACTOR & OVER LIMIT CALCULATION.....	14
TEST RESULTS SUMMARY	14
TEST DATA	14
FCC§15.323 (A) - EMISSION BANDWIDTH.....	17
APPLICABLE STANDARD	17
TEST PROCEDURE	17
TEST DATA	17
FCC§15.319 (C) - PEAK TRANSMIT POWER.....	22
APPLICABLE STANDARD	22
TEST PROCEDURE	22
TEST DATA	23
FCC§15.319 (D) - POWER SPECTRAL DENSITY	28
APPLICABLE STANDARD	28
TEST PROCEDURE	28
TEST DATA	28

FCC§15.323 (D) - EMISSION INSIDE AND OUTSIDE THE SUB-BAND.....33
 APPLICABLE STANDARD33
 TEST PROCEDURE33
 TEST DATA33

FCC§15.323 (F) - FREQUENCY STABILITY.....43
 APPLICABLE STANDARD43
 TEST PROCEDURE43
 TEST DATA43

FCC§15.323 (C) (E) & §15.319(F) – SPECIFIC REQUIREMENTS FOR UPCS DEVICE.....45
 APPLICABLE STANDARD45
 TEST PROCEDURE45
 TEST DATA45

EUT PHOTOGRAPHS.....51

TEST SETUP PHOTOGRAPHS.....52

DOCUMENT REVISION HISTORY

Revision Number	Report Number	Description of Revision	Date of Revision
0	SZGMA231215-75845E-RF-00A	Original Report	2024/01/31

GENERAL INFORMATION

Product Description for Equipment under Test (EUT)

Product	TELEPHONE
Tested Model	4304328
Multiple Model(s)	GCE8108L
Frequency Range	1921.536-1928.448 MHz
Maximum conducted peak output power	20.6dBm
Modulation Technique	GFSK
Antenna Specification [#]	0dBi(It is provided by the applicant)
Voltage Range	DC 6V from adapter
Sample serial number	2G8Q-10 for AC Conducted Emissions Test 2G8Q-1 for RF Conducted Test (Assigned by BACL, Shenzhen)
Sample/EUT Status	Good condition
Adapter Information	Model: GCE060050F Input: AC 100-240V~50/60Hz, 150mA Output: DC 6V, 500mA
Note: The Multiple models are electrically identical with the test model except for model name. Please refer to the declaration letter [#] for more detail, which was provided by manufacturer.	

Objective

The tests were performed in order to determine the compliance of the EUT with FCC Part 15-Subpart D, section 15.207, 15.315, 15.317, 15.319 and 15.323 rules. The EMI measurements were performed according to the measurement procedure described in ANSI C63.17 – 2013.

Test Methodology

All measurements contained in this report were conducted with ANSI C63.17 - 2013, American National Standard Methods of Measurement of the Electromagnetic and Operational Compatibility of Unlicensed Personal Communications Services (UPCS) Devices.

All emissions measurement was performed at Bay Area Compliance Laboratories Corp. (Shenzhen). The radiated testing was performed at an antenna-to-EUT distance of 3 meters.

Each test item follows test standards and with no deviation.

Measurement Uncertainty

Parameter		Uncertainty
Occupied Channel Bandwidth		±5%
RF Frequency		213.55 Hz(k=2, 95% level of confidence)
RF output power, conducted		0.72 dB(k=2, 95% level of confidence)
Unwanted Emission, conducted		1.75 dB(k=2, 95% level of confidence)
AC Power Lines Conducted Emissions	9kHz-150kHz	3.94dB(k=2, 95% level of confidence)
	150kHz-30MHz	3.84dB(k=2, 95% level of confidence)
Temperature		±1°C
Humidity		±1%
Supply voltages		±0.4%

Note: The extended uncertainty given in this report is obtained by combining the standard uncertainty times the coverage factor K with the 95% confidence interval. Otherwise required by the applicant or Product Regulations, Decision Rule in this report did not consider the uncertainty.

Test Facility

The Test site used by Bay Area Compliance Laboratories Corp. (Shenzhen) to collect test data is located on the 5F(B-West) , 6F, 7F, the 3rd Phase of Wan Li Industrial Building D, Shihua Rd, FuTian Free Trade Zone, Shenzhen, China.

The lab has been recognized as the FCC accredited lab under the KDB 974614 D01 and is listed in the FCC Public Access Link (PAL) database, FCC Registration No. : 715558, the FCC Designation No. : CN5045.

SYSTEM TEST CONFIGURATION

Description of Test Configuration

The system was configured to testing mode which is provided by the manufacturer.

Equipment Modifications

No modification was made to the EUT tested.

Local Support Equipment List and Details

Manufacturer	Description	Model	Serial Number
Rohde & Schwarz	Digital Radio Communication Tester	CMD60	830861/029
RADIOSHACK WORLDWIDE CORP.	Handset	4304328	2G8Q-2

External I/O Cable

Cable Description	Length (m)	From Port	To
Un-shielding Un-detachable DC Cable	0.5	EUT	Adapter
Unshielded Detachable AC Cable	1.2	AC Power	CMD60

Block Diagram of Test Setup

For conducted emission

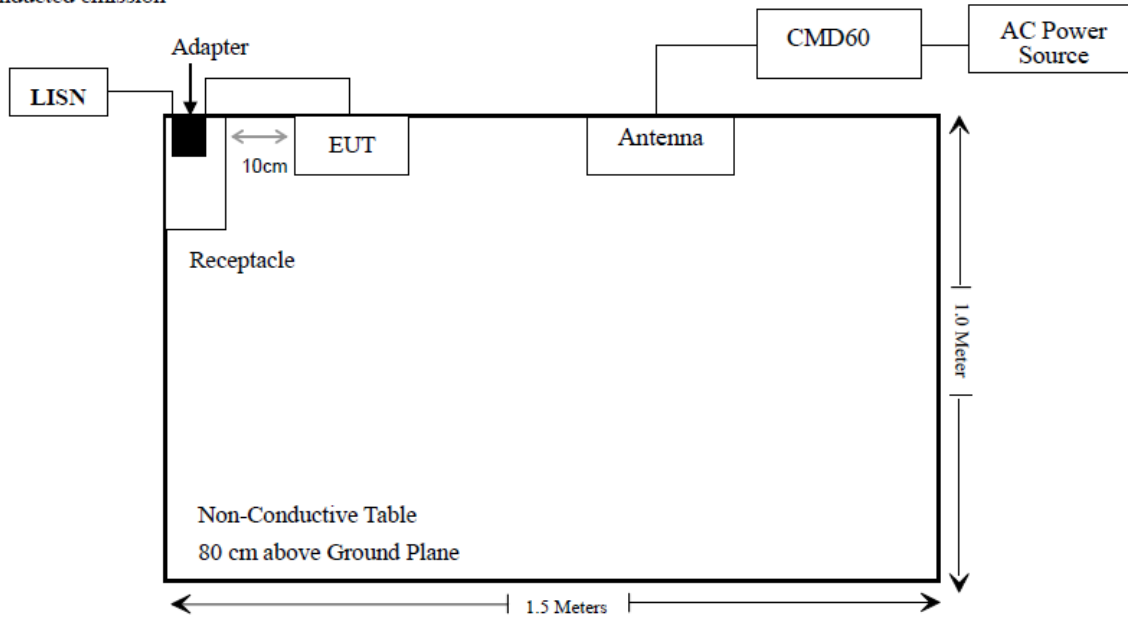

SUMMARY OF TEST RESULTS

FCC Rules	Description of Test	Result
§ 1.1310 & §2.1091	RF Exposure Evaluation	Compliant
§ 15.317, § 15.203	Antenna Requirement	Compliant
§ 15.315, § 15.207	Conducted Emission	Compliant
§ 15.323 (a)	Emission Bandwidth	Compliant
§ 15.319 (c)	Peak Transmit Power	Compliant
§ 15.319 (d)	Power Spectral Density	Compliant
§ 15.323 (d)	Emission Inside and Outside the sub-band	Compliant
§ 15.323 (f)	Frequency Stability	Compliant
§ 15.323 (c)(e) § 15.319 (f)	Specific Requirements for UPCS	Compliant

Note: the device has two antennas (ANT0 and ANT1), pre-scan with the power of the two antennas, the power of ANT0 was the larger one which was chosen for the full test.

TEST EQUIPMENT LIST

Manufacturer	Description	Model	Serial Number	Calibration Date	Calibration Due Date
Conducted Emissions Test					
Rohde & Schwarz	EMI Test Receiver	ESCI	101120	2024/01/16	2025/01/15
Rohde & Schwarz	LISN	ENV216	101613	2024/01/16	2025/01/15
Unknown	CE Cable	CE Cable	UF A210B-1-0720-504504	2023/08/03	2024/08/02
Audix	EMI Test software	E3	191218	NCR	NCR
RF Conducted Test					
Rohde & Schwarz	SPECTRUM ANALYZER	FSU26	200982	2023/12/18	2024/12/17
BACL	Temperature & Humidity Chamber	BTH-150-40	30145	2024/01/16	2025/01/15
Rohde & Schwarz	Digital Radio Communication Tester	CMD60	830553/018	2023/06/08	2024/06/07
Keysight	MXG Vector Signal Generator	N5182B	MY53051503	2024/01/08	2025/01/07
WEINSCHTEL	Power Splitter	1515	RH386	2023/07/04	2024/07/03
Fluke	Digital Multimeter	287	19000011	2023/06/08	2024/06/07
HELLVIAO	Contact voltage regulator	TDGC2-5KVA	Unknown	NCR	NCR
Unknown	RF Cable	65475	01670515	2023/07/04	2024/07/03

* **Statement of Traceability:** Bay Area Compliance Laboratories Corp. (Shenzhen) attests that all calibrations have been performed in accordance to requirements that traceable to National Primary Standards and International System of Units (SI).

FCC §1.1307(b) & §2.1091 – RF EXPOSURE EVALUATION

Applicable Standard

According to KDB 447498 D04 Interim General RF Exposure Guidance v01, clause 2.1.4 –MPE-Based Exemption:

An alternative to the SAR-based exemption is provided in § 1.1307(b)(3)(i)(C), for a much wider frequency range, from 300 kHz to 100 GHz, applicable for separation distances greater or equal to $\lambda/2\pi$, where λ is the free-space operating wavelength in meters. The MPE-based test exemption condition is in terms of ERP, defined as the product of the maximum antenna gain and the delivered maximum time-averaged power. For this case, a RF source is an RF exempt device if its ERP (watts) is no more than a frequency-dependent value, as detailed tabular form in Appendix B. These limits have been derived based on the basic specifications on Maximum Permissible Exposure (MPE) considered for the FCC rules in § 1.1310(e)(1).

Table to § 1.1307(b)(3)(i)(C) - Single RF Sources Subject to Routine Environmental Evaluation

RF Source frequency (MHz)	Threshold ERP (watts)
0.3-1.34	$1,920 R^2$.
1.34-30	$3,450 R^2/f^2$.
30-300	$3.83 R^2$.
300-1,500	$0.0128 R^2f$.
1,500-100,000	$19.2R^2$.

f = frequency in MHz;

R = minimum separation distance from the body of a nearby person (appropriate units, e.g., m);

Result

Mode	Frequency (MHz)	Tune up conducted power	Antenna Gain [#]		ERP		Evaluation Distance (m)	MPE-Based Exemption Threshold (mW)
		(dBm)	(dBi)	(dBd)	(dBm)	(mW)		
DECT	1921.536-1928.448	21.0	0	-2.15	18.85	76.74	0.2	768

Note 1: The tune-up power and antenna gain was declared by the applicant.

Note 2: 0dBd=2.15dBi.

Result: Compliant

§ 15.317, § 15.203 ANTENNA REQUIREMENT

Applicable Standard

According to FCC § 15.203, an intentional radiator shall be designed to ensure that no antenna other than that furnished by the responsible party shall be used with the device. The use of a permanently attached antenna or of an antenna that uses a unique coupling to the intentional radiator shall be considered sufficient to comply with the provisions of this Section. The manufacturer may design the unit so that a broken antenna can be replaced by the user, but the use of a standard antenna jack or electrical connector is prohibited.

Antenna Connector Construction

The EUT has two antennas which were permanently attached and the maximum antenna gain[#] is 0dBi, fulfill the requirement of this section. Please refer to the EUT photos.

Result: Compliant

FCC§15.315 & §15.207 - CONDUCTED EMISSIONS

Applicable Standard

FCC§15.315, an unlicensed PCS device that is designed to be connected to the public utility (AC) power line must meet the limits specified in §15.207.

EUT Setup

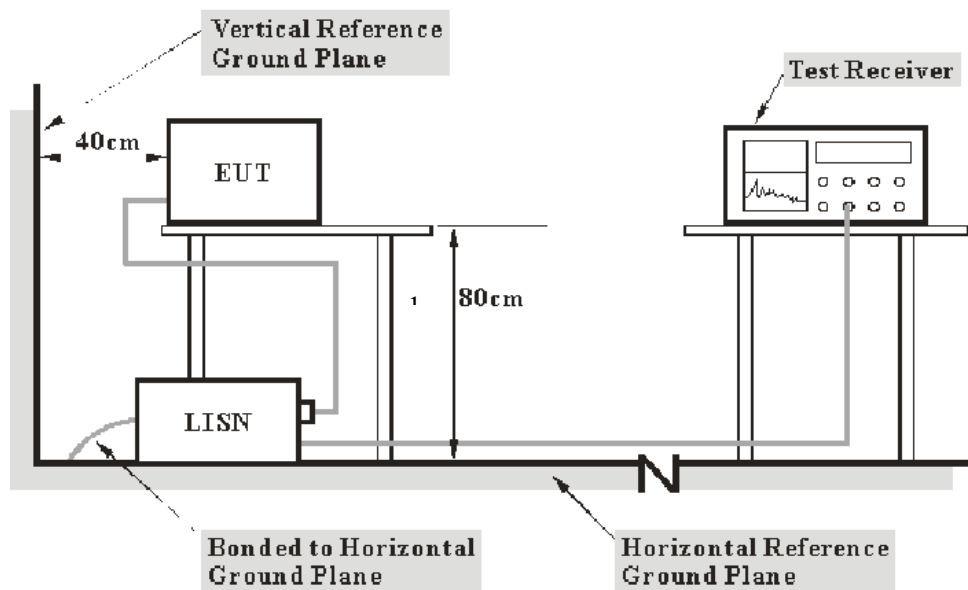

- Note: 1. Support units were connected to second LISN.
 2. Both of LISNs (AMN) 80 cm from EUT and at the least 80 cm from other units and other metal planes support units.

The setup of EUT is according with per ANSI C63.10-2013 measurement procedure. The specification used was with the FCC 15.315 and FCC 15.207 limits.

The external I/O cables were draped along the test table and formed a bundle 30 to 40 cm long in the middle.

The spacing between the peripherals was 10 cm.

The adapter was connected to a 120 VAC/60 Hz power source.

EMI Test Receiver Setup

The EMI test receiver was set to investigate the spectrum from 150 kHz to 30 MHz.

During the conducted emission test, the EMI test receiver was set with the following configurations:

Frequency Range	IF B/W
150 kHz – 30 MHz	9 kHz

Test Procedure

During the conducted emission test, adapter was connected to the outlet of the LISN.

Maximizing procedure was performed on the six (6) highest emissions of the EUT.

All final data was recorded in the Quasi-peak and average detection mode.

Factor & Over Limit Calculation

The factor is calculated by adding LISN VDF (Voltage Division Factor) and Cable Loss. The basic equation is as follows:

$$\text{Factor} = \text{LISN VDF} + \text{Cable Loss}$$

The “**Over limit**” column of the following data tables indicates the degree of compliance with the applicable limit. For example, an Over limit of -7 dB means the emission is 7 dB below the limit. The equation for calculation is as follows:

$$\begin{aligned} \text{Over Limit} &= \text{Level} - \text{Limit} \\ \text{Level} &= \text{Read Level} + \text{Factor} \end{aligned}$$

Note: The term "cable loss" refers to the combination of a cable and a 10dB transient limiter (attenuator).

Test Results Summary

According to the recorded data in following table, the EUT complied with the FCC Part 15.207.

Test Data

Environmental Conditions

Temperature:	25 °C
Relative Humidity:	47 %
ATM Pressure:	101 kPa

The testing was performed by Macy Shi on 2024-01-22.

Test mode: Transmitting (Maximum output power: Low channel)

AC 120V/60 Hz, Line

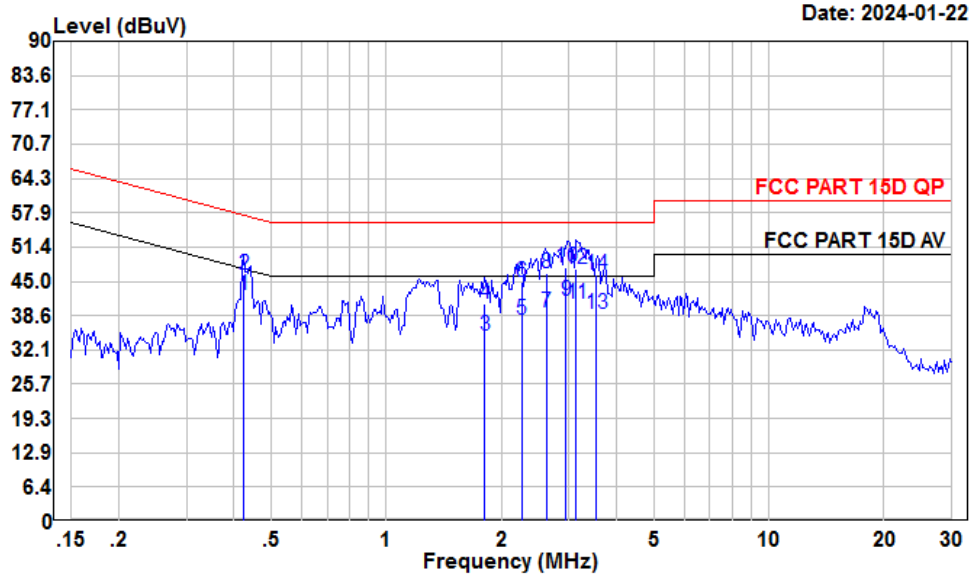

Date: 2024-01-22

Condition: Line
 Project : SZGMA231215-75845E-RF
 Tester : Macy shi
 Note : GFSK

	Read Freq	Read Level	Cable Level	Cable Loss	LISN Factor	Limit Line	Over Limit	Remark
	MHz	dBuV	dBuV	dB	dB	dBuV	dB	
1	0.42	21.60	42.48	10.20	10.68	47.37	-4.89	Average
2	0.42	25.44	46.32	10.20	10.68	57.37	-11.05	QP
3	1.81	13.98	34.91	10.14	10.79	46.00	-11.09	Average
4	1.81	19.99	40.92	10.14	10.79	56.00	-15.08	QP
5	2.26	16.81	37.77	10.20	10.76	46.00	-8.23	Average
6	2.26	23.91	44.87	10.20	10.76	56.00	-11.13	QP
7	2.62	18.21	39.15	10.22	10.72	46.00	-6.85	Average
8	2.62	25.51	46.45	10.22	10.72	56.00	-9.55	QP
9	2.95	20.30	41.25	10.26	10.69	46.00	-4.75	Average
10	2.95	26.70	47.65	10.26	10.69	56.00	-8.35	QP
11	3.14	19.78	40.72	10.27	10.67	46.00	-5.28	Average
12	3.14	26.30	47.24	10.27	10.67	56.00	-8.76	QP
13	3.53	18.00	38.90	10.26	10.64	46.00	-7.10	Average
14	3.53	25.20	46.10	10.26	10.64	56.00	-9.90	QP

AC 120V/60 Hz, Neutral

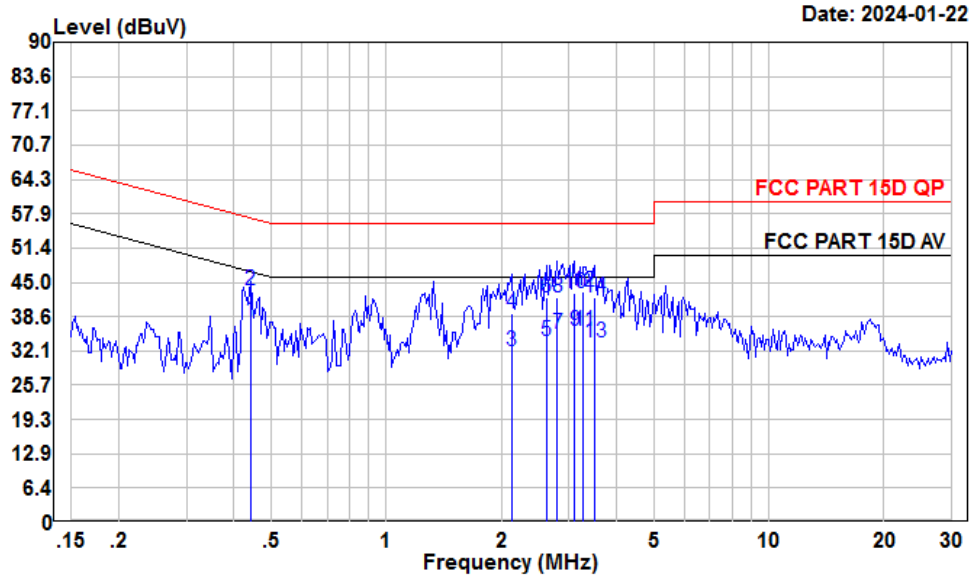

Condition: Neutral
 Project : SZGMA231215-75845E-RF
 Tester : Macy shi
 Note : GFSK

	Read Freq	Read Level	Cable Level	Cable Loss	LISN Factor	Limit Line	Over Limit	Remark
	MHz	dBuV	dBuV	dB	dB	dBuV	dB	
1	0.44	16.81	37.79	10.19	10.79	47.02	-9.23	Average
2	0.44	22.67	43.65	10.19	10.79	57.02	-13.37	QP
3	2.12	11.10	31.99	10.19	10.70	46.00	-14.01	Average
4	2.12	18.40	39.29	10.19	10.70	56.00	-16.71	QP
5	2.62	13.10	34.02	10.22	10.70	46.00	-11.98	Average
6	2.62	21.20	42.12	10.22	10.70	56.00	-13.88	QP
7	2.79	14.50	35.45	10.25	10.70	46.00	-10.55	Average
8	2.79	21.30	42.25	10.25	10.70	56.00	-13.75	QP
9	3.11	14.82	35.79	10.27	10.70	46.00	-10.21	Average
10	3.11	22.10	43.07	10.27	10.70	56.00	-12.93	QP
11	3.28	14.80	35.77	10.27	10.70	46.00	-10.23	Average
12	3.28	22.40	43.37	10.27	10.70	56.00	-12.63	QP
13	3.49	12.80	33.77	10.27	10.70	46.00	-12.23	Average
14	3.49	21.20	42.17	10.27	10.70	56.00	-13.83	QP

FCC§15.323 (a) - EMISSION BANDWIDTH

Applicable Standard

Operation shall be contained within the 1920–1930 MHz band. The emission bandwidth shall be less than 2.5 MHz and greater than 50 kHz.

The emission bandwidth is measured in accordance with ANSI C63.17 sub-clause 6.1.3 using the setup below:

Test Setup 1:

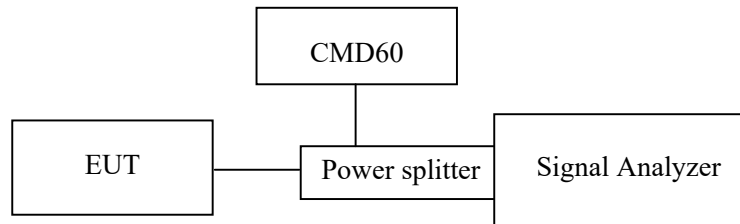

The width, in Hz, of the signal between two points, one below the carrier center frequency and one above the carrier center frequency, that is 26 dB down relative to the maximum level of the modulated carrier. It is based on the use of measurement instrumentation employing a peak detector function with an instrument resolution bandwidth approximately equal to 1% of the emission band-width of the device under measurement. [Extraction from 47 CFR 15, subpart D, 15.303 (C)].

Test Procedure

Using the manufacturer’s information on occupied bandwidth set the spectrum analyzer as follows:

Resolution bandwidth	1.0% of the emission bandwidth (as close as possible)
Video bandwidth	>3 times the resolution bandwidth
Number of sweeps	sufficient to stability the trace
Detection mode	peak detection with maximum hold

Test Data

Environmental Conditions

Temperature:	25~26 °C
Relative Humidity:	45~46 %
ATM Pressure:	101 kPa

The testing was performed by Hanic Pan on 2024-01-25.

Test mode: Transmitting

Test Result: Compliant. Please refer to the following table and plots.

Channel	Center Frequency (MHz)	99% Emission Bandwidth (MHz)	26 dB Emission Bandwidth (MHz)	Limit
Low	1921.536	1.188	1.466	50 kHz ~ 2.5 MHz
Middle	1924.992	1.215	1.418	50 kHz ~ 2.5 MHz
High	1928.448	1.218	1.413	50 kHz ~ 2.5 MHz

26 dB Emission Bandwidth

Low Channel

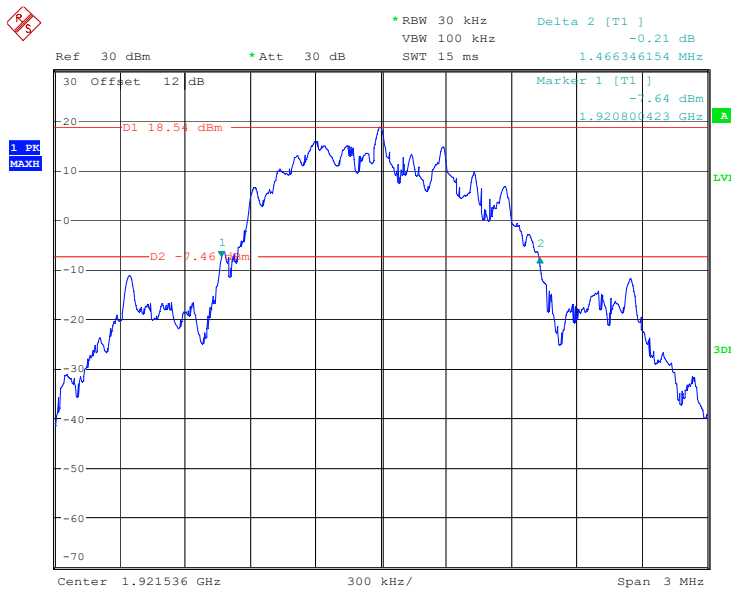

ProjectNo.:SZGMA231215-75845E-RF Tester:Hanic Pan
 Date: 25.JAN.2024 15:57:02

Middle Channel

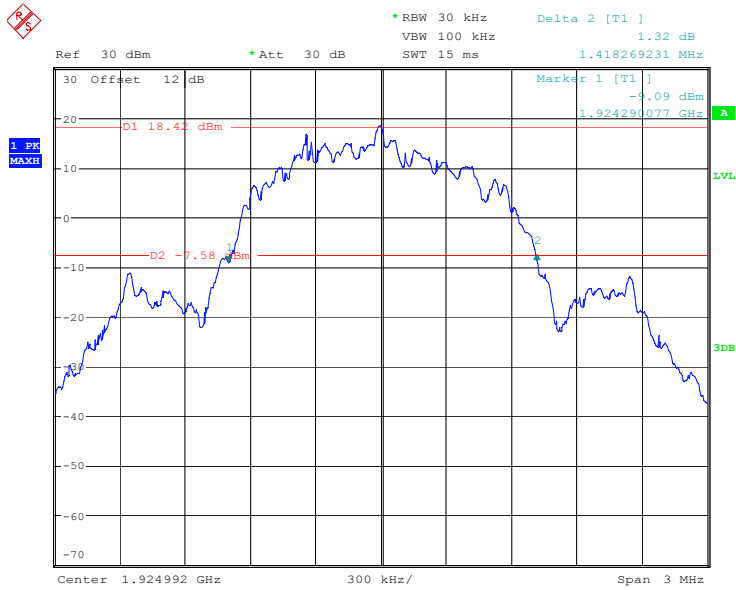

ProjectNo.:SZGMA231215-75845E-RF Tester:Hanic Pan
 Date: 25.JAN.2024 16:23:58

High Channel

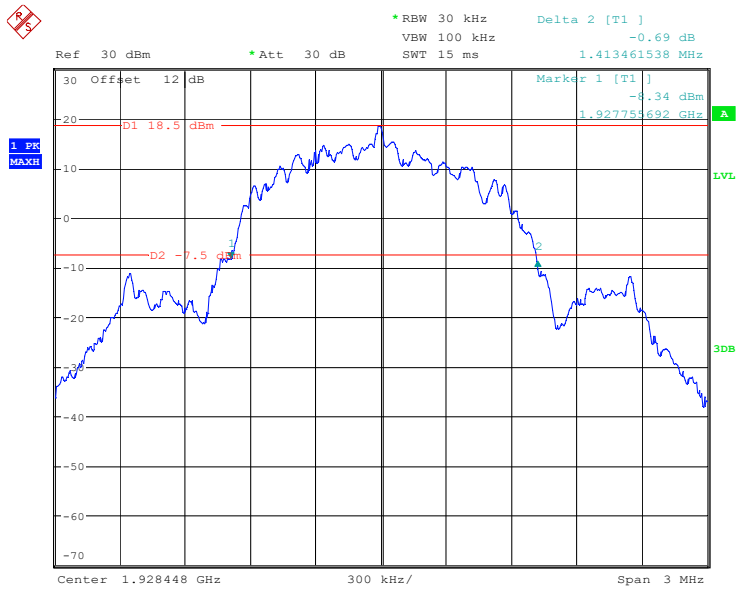

ProjectNo.:SZGMA231215-75845E-RF Tester:Hanic Pan
 Date: 25.JAN.2024 16:39:45

99% Emission Bandwidth

Low Channel

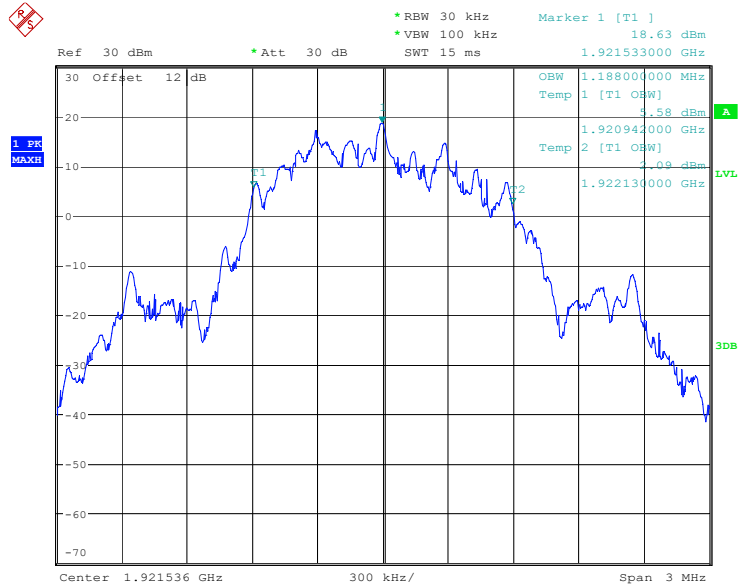

ProjectNo.:SZGMA231215-75845E-RF Tester:Hanic Pan
 Date: 25.JAN.2024 15:56:11

Middle Channel

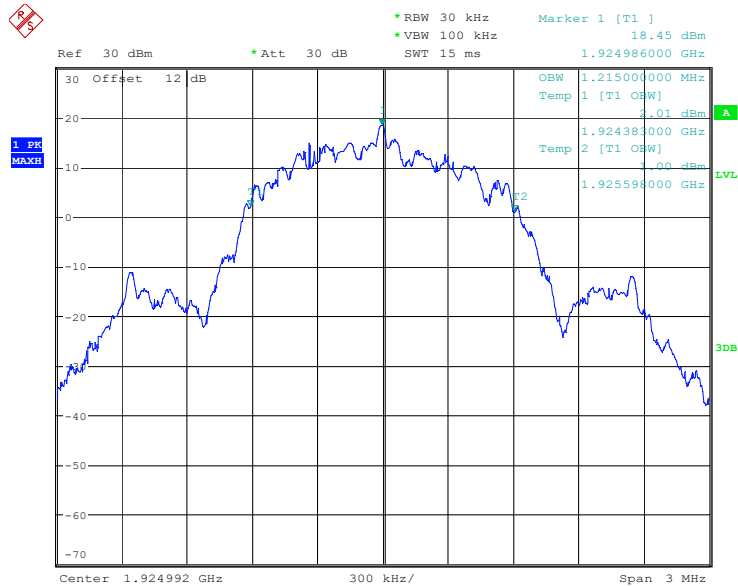

ProjectNo.:SZGMA231215-75845E-RF Tester:Hanic Pan
 Date: 25.JAN.2024 16:23:06

High Channel

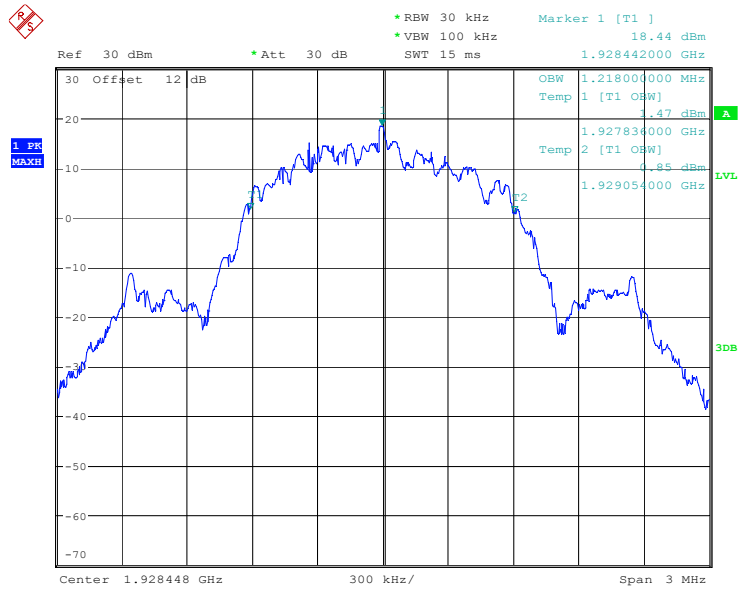

ProjectNo.:SZGMA231215-75845E-RF Tester:Hanic Pan
Date: 25.JAN.2024 16:39:04

FCC§15.319 (c) - PEAK TRANSMIT POWER

Applicable Standard

The peak power output as measured over an interval of time equal to the frame rate or transmission burst of the device under all conditions of modulation. Usually this parameter is measured as a conducted emission by direct connection of a calibrated test instrument to the equipment under test. If the device cannot be connected directly, alternative techniques acceptable to the Commission may be used[47 CFR 15, subpart D, 15.303].

The peak transmit power is according to ANSI C63.17-2013 §6.1.2

Per FCC Part15.319 (c) Peak transmit power shall not exceed 100 microwatts multiplied by the square root of the emission bandwidth in hertz. Peak transmit power must be measured over any interval of continuous transmission using instrumentation calibrated in terms of an rms-equivalent voltage. The measurement results shall be properly adjusted for any instrument limitations, such as detector response times, limited resolution bandwidth capability when compared to the emission bandwidth, sensitivity, etc., so as to obtain a true peak measurement for the emission in question over the full bandwidth of the channel.

Per FCC Part15.319 (e), the peak transmit power shall be reduced by the amount in decibels that the maximum directional gain of the antenna exceeds 3 dBi.

Calculation of Peak Transmit Power Limit:

$$\text{Peak Transmit Power Limit} = 100\mu\text{W} \times (\text{EBW})^{1/2}$$

EBW is the transmit emission bandwidth in Hz determined in the other test item:

Test Procedure

Using the manufacturer’s information on occupied bandwidth set the spectrum analyzer as follows:

RBW	≥ Emission bandwidth
Video bandwidth	≥ RBW
Span	Zero
Center frequency	Nominal center frequency of channels
Amplitude scale	Log (linear may be used if analyzer has sufficient linear dynamic range and accuracy)
Detection	Peak detection
Trigger	Video
Sweep rate	Sufficiently rapid to permit the transmit pulse to be resolved accurately

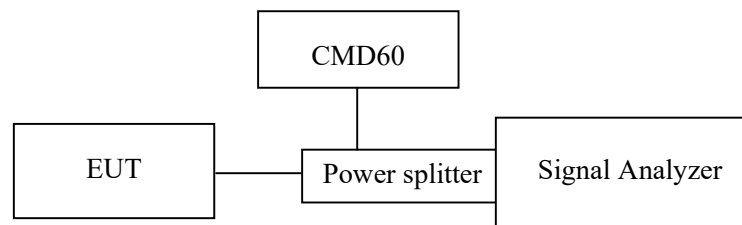

Test Data

Environmental Conditions

Temperature:	25~26 °C
Relative Humidity:	45~46 %
ATM Pressure:	101 kPa

The testing was performed by Hanic Pan on 2024-01-25.

Test mode: Transmitting

Test Result: Compliant. Please refer to the following table and plots.

ANT 0

Channel	Frequency (MHz)	Peak Transmit Power (dBm)	Limit (dBm)
Low	1921.536	20.60	20.83
Middle	1924.992	20.52	20.76
High	1928.448	20.46	20.75

ANT 1

Channel	Frequency (MHz)	Peak Transmit Power (dBm)	Limit (dBm)
Low	1921.536	19.57	20.83
Middle	1924.992	19.58	20.76
High	1928.448	19.59	20.75

ANT 0

Low Channel

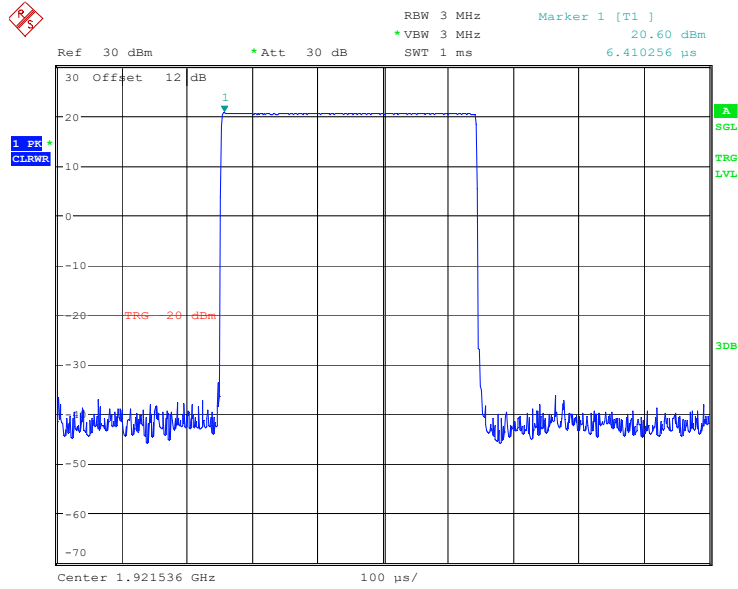

ProjectNo.:SZGMA231215-75845E-RF Tester:Hanic Pan
Date: 25.JAN.2024 15:48:27

Middle Channel

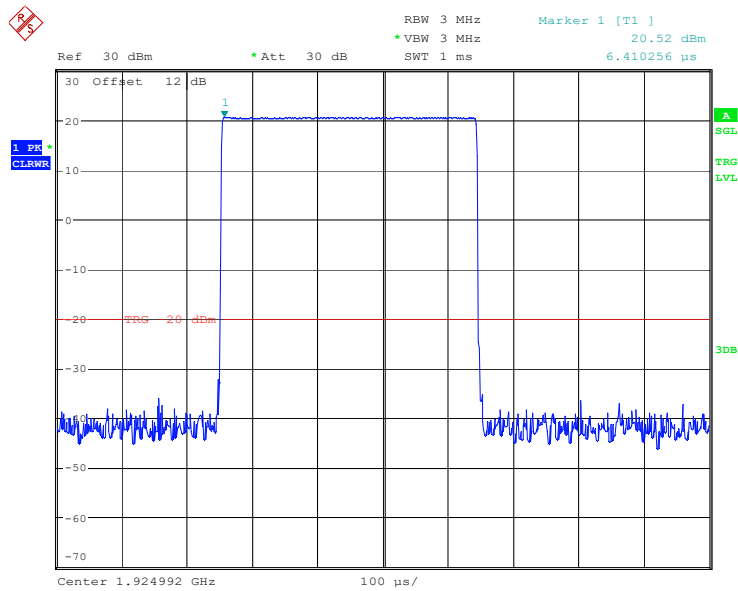

ProjectNo.:SZGMA231215-75845E-RF Tester:Hanic Pan
Date: 25.JAN.2024 16:24:33

High Channel

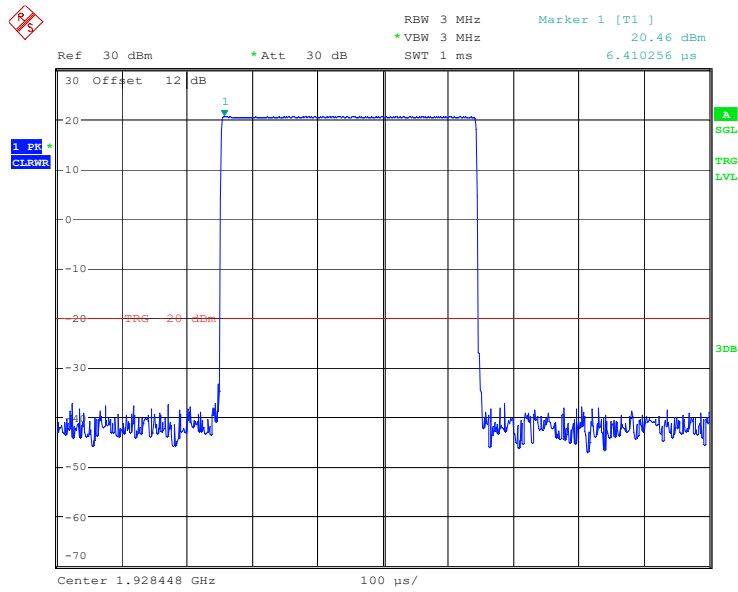

ProjectNo.:SZGMA231215-75845E-RF Tester:Hanic Pan
Date: 25.JAN.2024 16:37:05

ANT 1

Low Channel

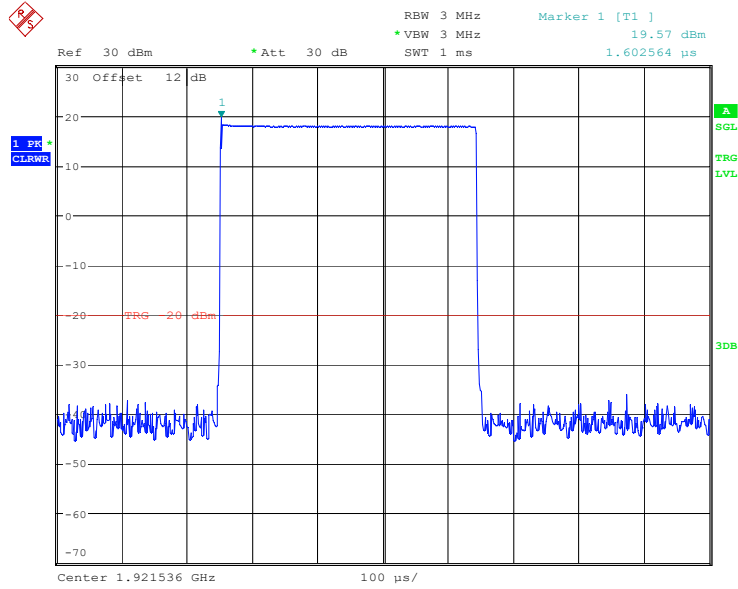

ProjectNo.:SZGMA231215-75845E-RF Tester:Hanic Pan
Date: 25.JAN.2024 15:22:05

Middle Channel

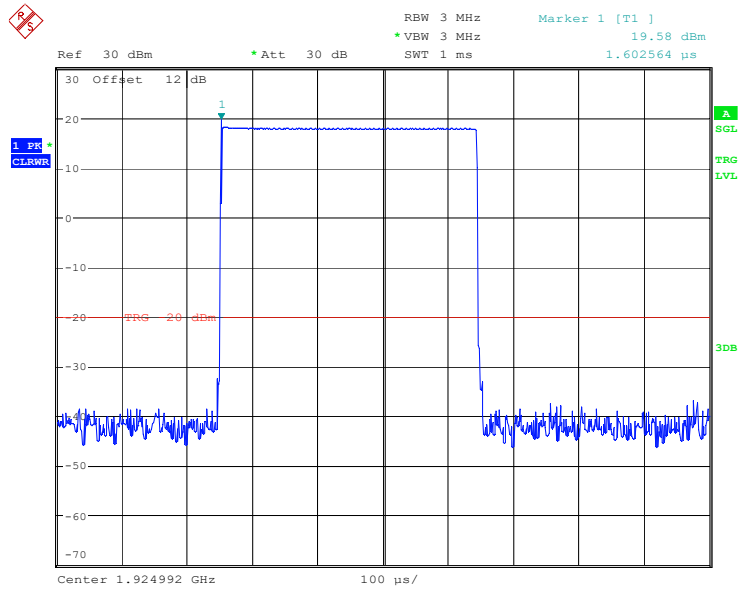

ProjectNo.:SZGMA231215-75845E-RF Tester:Hanic Pan
Date: 25.JAN.2024 15:21:11

High Channel

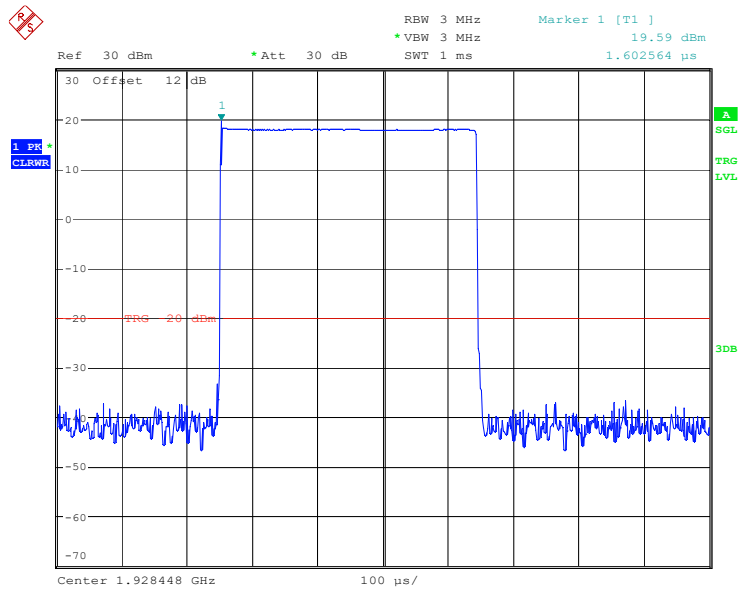

ProjectNo.:SZGMA231215-75845E-RF Tester:Hanic Pan
Date: 25.JAN.2024 15:19:59

FCC§15.319 (d) - POWER SPECTRAL DENSITY

Applicable Standard

The average pulse energy in a 3 kHz bandwidth is divided by the pulse duration.

The power spectral density shall not exceed 3mW in any 3 kHz bandwidth as measured with a spectrum analyzer having a resolution bandwidth of 3 kHz.

The power spectral density is measured in accordance with ANSI C63.17.2013 Clause 6.1.5.

Test Procedure

Using the manufacturer’s information on occupied bandwidth set the spectrum analyzer as follows:

RBW	3 kHz
Video bandwidth	$\geq 3 \times \text{RBW}$
Span	Zero span at frequency with the maximum level (frequency determined in 6.1.3 if the same type of signal (continuous versus burst) was used in 6.1.3)
Center frequency	Spectral peak as determined in 6.1.3
Sweep time	For burst signals, sufficient to include essentially all of the maximum length burst at the output of a 3 kHz filter (e.g., maximum input burst duration plus 600 μs). For continuous signals, 20 ms.
Amplitude scale	Log power
Detection	Sample detection and averaged for a minimum of 100 sweeps
Trigger	External or internal

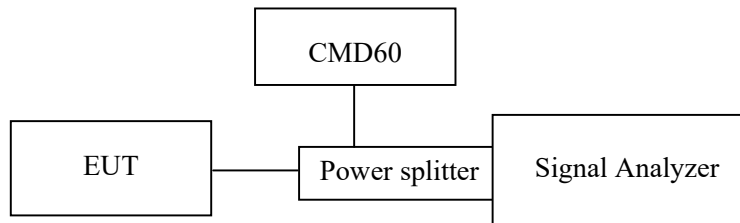

Test Data

Environmental Conditions

Temperature:	25~26 °C
Relative Humidity:	45~46 %
ATM Pressure:	101 kPa

The testing was performed by Hanic Pan on 2024-01-25.

Test mode: Transmitting

Test Result: Compliant. Please refer to following table and plots

Channel	Frequency (MHz)	Power Spectral Density		Limit (mW/3kHz)
		(dBm/3kHz)	(mW/3kHz)	
Low	1921.536	0.38	1.091	3
Middle	1924.992	-0.05	0.989	3
High	1928.448	-1.49	0.710	3

Low Channel

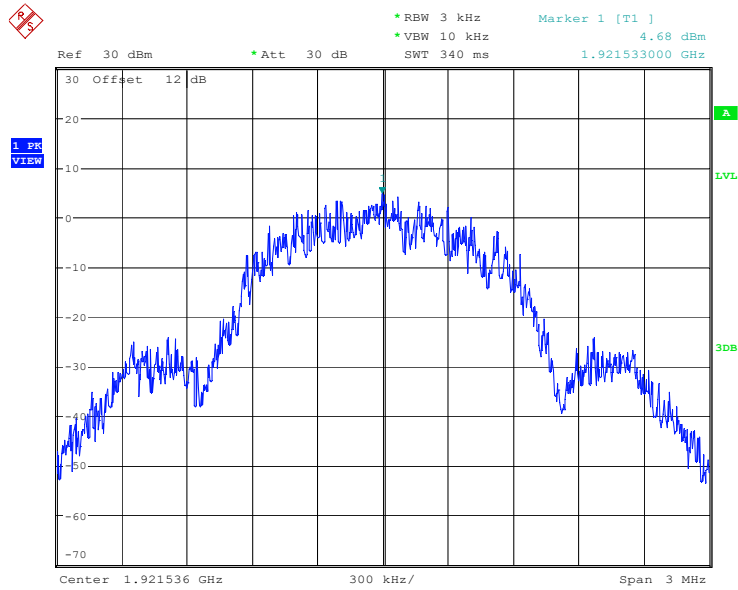

ProjectNo.:SZGMA231215-75845E-RF Tester:Hanic Pan
Date: 25.JAN.2024 16:52:52

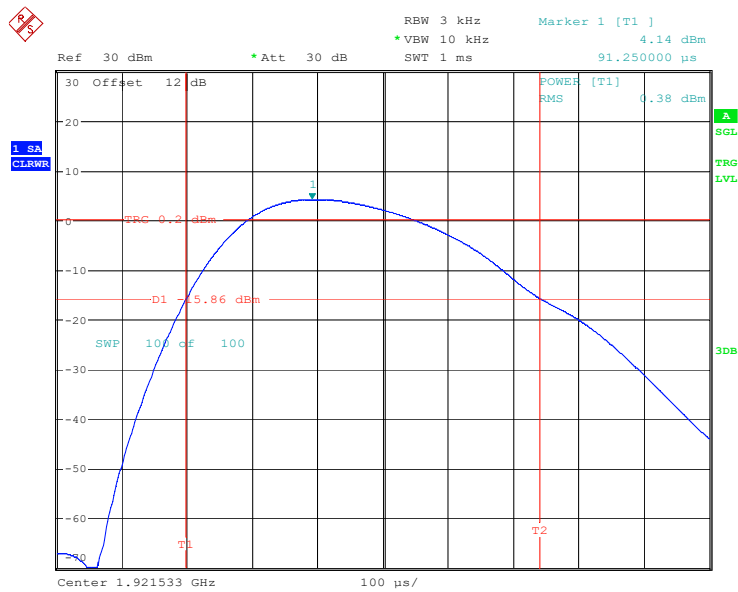

ProjectNo.:SZGMA231215-75845E-RF Tester:Hanic Pan
Date: 25.JAN.2024 16:54:58

Middle Channel

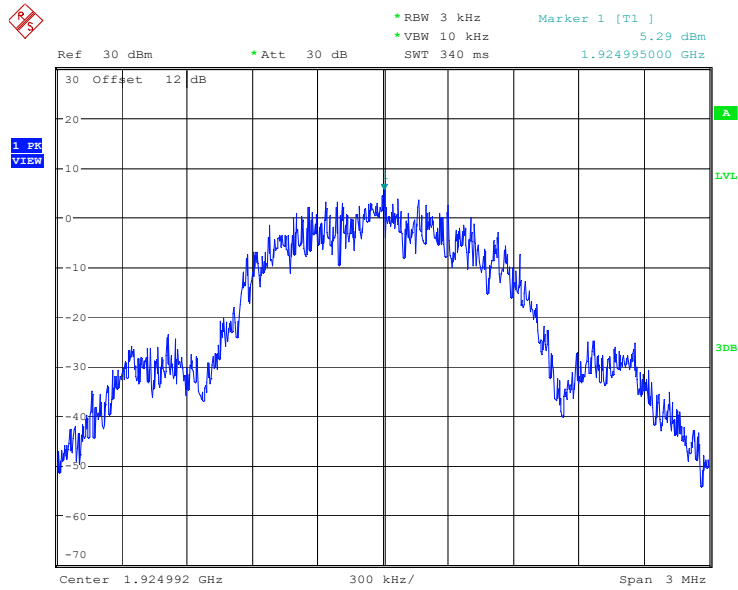

ProjectNo.:SZGMA231215-75845E-RF Tester:Hanic Pan
Date: 25.JAN.2024 16:19:19

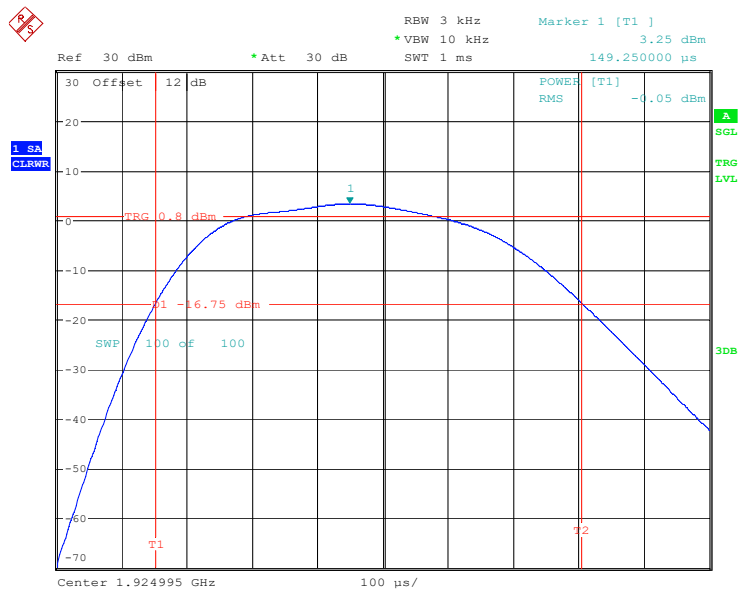

ProjectNo.:SZGMA231215-75845E-RF Tester:Hanic Pan
Date: 25.JAN.2024 16:21:21

High Channel

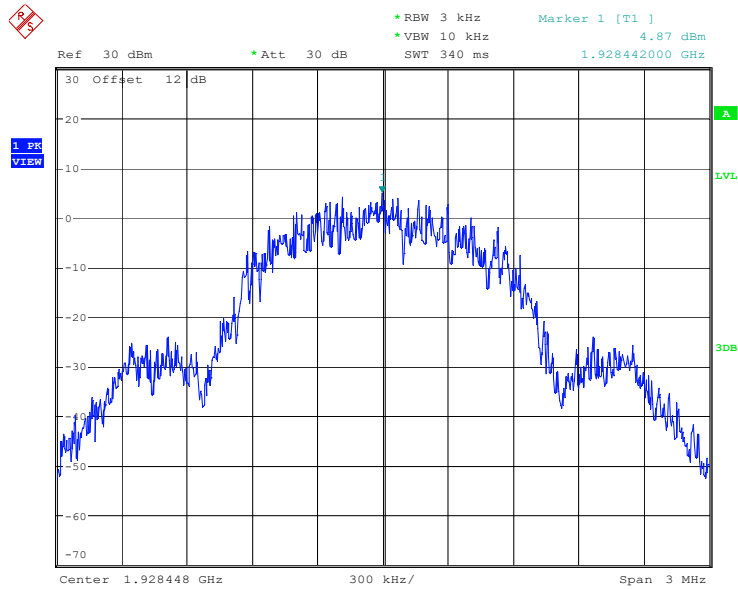

ProjectNo.:SZGMA231215-75845E-RF Tester:Hanic Pan
Date: 25.JAN.2024 16:48:09

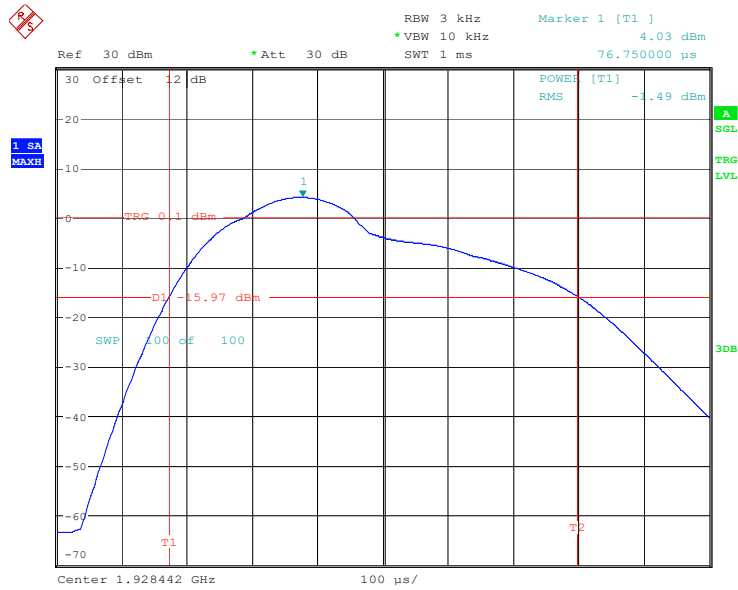

ProjectNo.:SZGMA231215-75845E-RF Tester:Hanic Pan
Date: 25.JAN.2024 16:50:18

FCC§15.323 (d) - EMISSION INSIDE AND OUTSIDE THE SUB-BAND

Applicable Standard

Emissions inside the sub-band must comply with the following emission mask:

1. In the bands between 1B and 2B measured from the center of the emission bandwidth the total power emitted by the device shall be at least 30 dB below the transmit power permitted for that device;
2. in the bands between 2B and 3B measured from the center of the emission bandwidth the total power emitted by an intentional radiator shall be at least 50 dB below the transmit power permitted for that radiator;
3. in the bands between 3B and the sub-band edge the total power emitted by an intentional radiator in the measurement bandwidth shall be at least 60 dB below the transmit power permitted for that radiator.

Where B = emission bandwidth

Emission Outside the sub-band shall be attenuated below a reference power of 112 mw (20.5 dBm) as follows:

1. 30 dB between the sub-band and 1.25 MHz above or below the sub-band;
2. 50 dB between 1.25 and 2.5 MHz above or below the sub-band;
3. 60 dB at 2.5 MHz or greater above or below the sub-band.

Test Procedure

According to ANSI C63.17-2013 Clause 6.1.6.

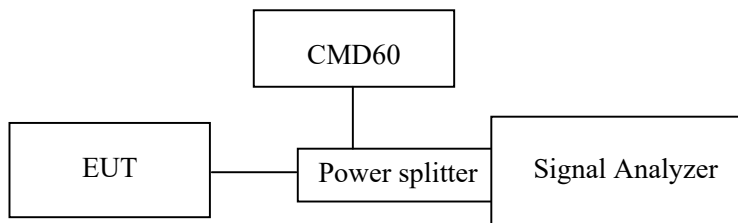

Test Data

Environmental Conditions

Temperature:	25~26 °C
Relative Humidity:	45~46 %
ATM Pressure:	101 kPa

The testing was performed by Hanic Pan on 2024-01-25.

Test mode: Transmitting

Test Result: Compliant. Please refer to following plots

Low Channel (Unwanted Emission inside the Sub-band)

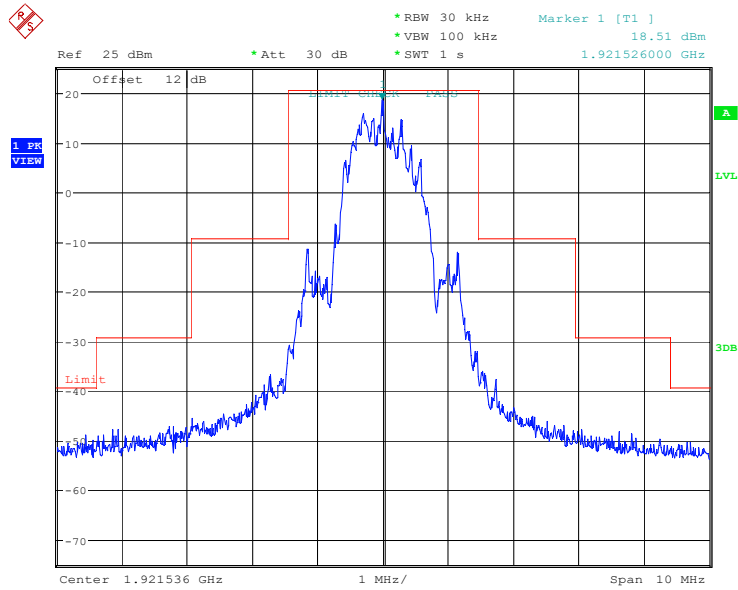

ProjectNo.:SZGMA231215-75845E-RF Tester:Hanic Pan
Date: 25.JAN.2024 15:49:46

Middle Channel (Unwanted Emission inside the Sub-band)

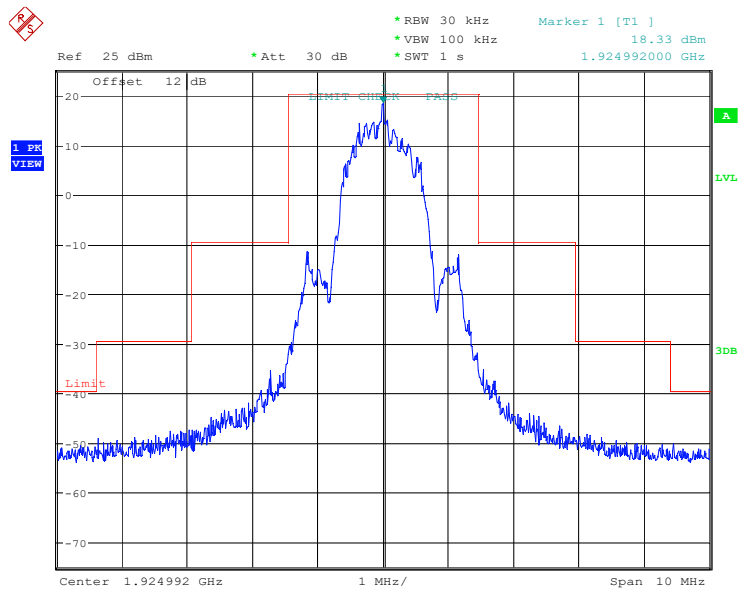

ProjectNo.:SZGMA231215-75845E-RF Tester:Hanic Pan
Date: 25.JAN.2024 16:25:56

High Channel (Unwanted Emission inside the Sub-band)

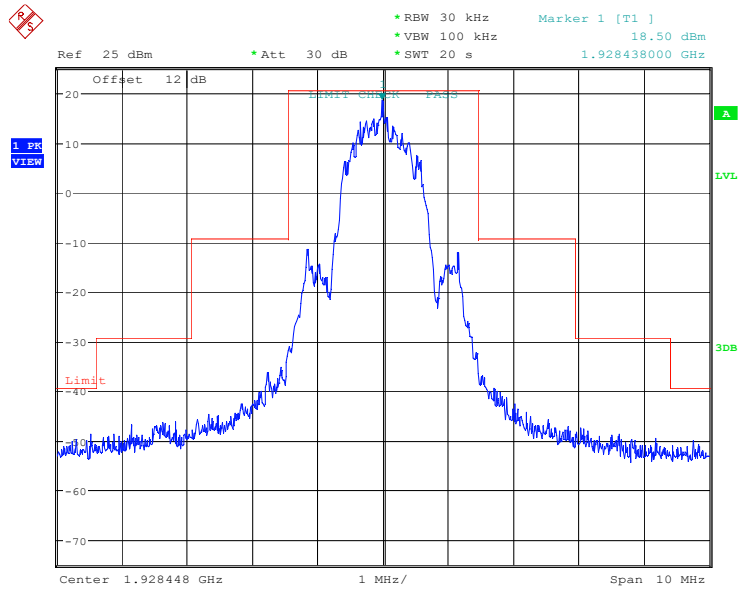

ProjectNo.:SZGMA231215-75845E-RF Tester:Hanic Pan
Date: 25.JAN.2024 16:32:27

Low Channel (Unwanted Emission outside the Sub-band)

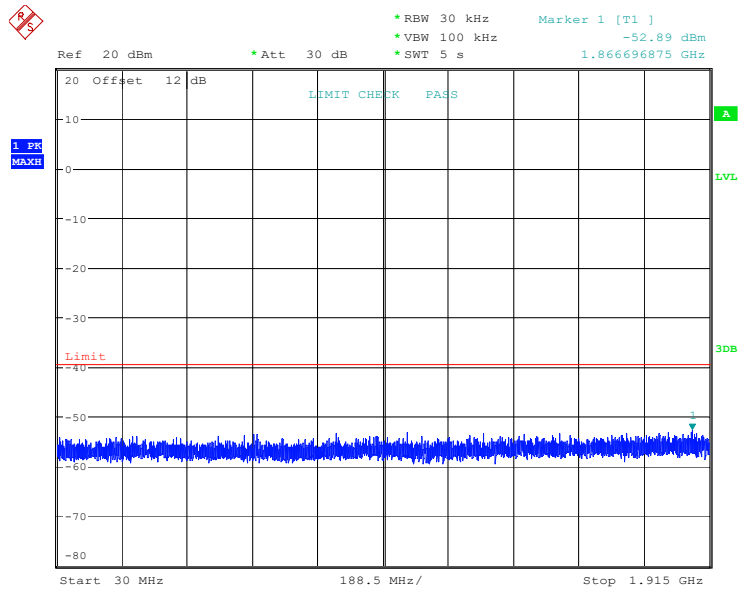

ProjectNo.:SZGMA231215-75845E-RF Tester:Hanic Pan
Date: 25.JAN.2024 15:50:28

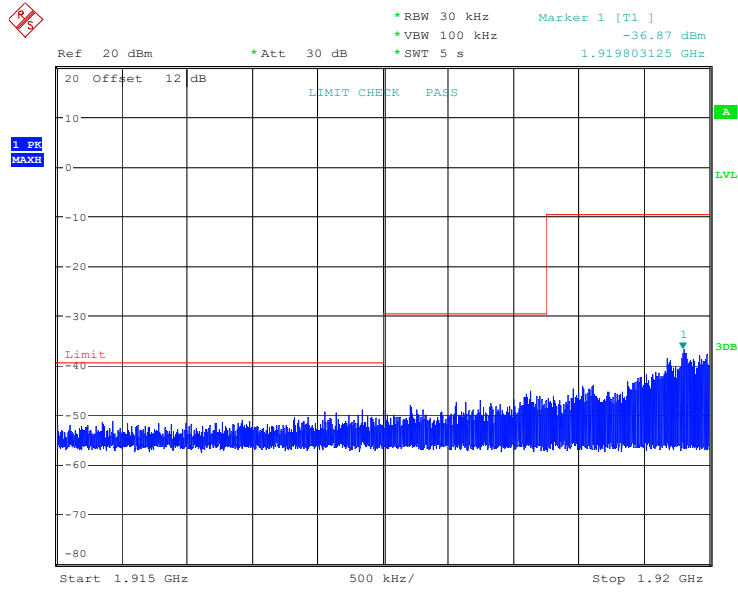

ProjectNo.:SZGMA231215-75845E-RF Tester:Hanic Pan
Date: 25.JAN.2024 15:51:10

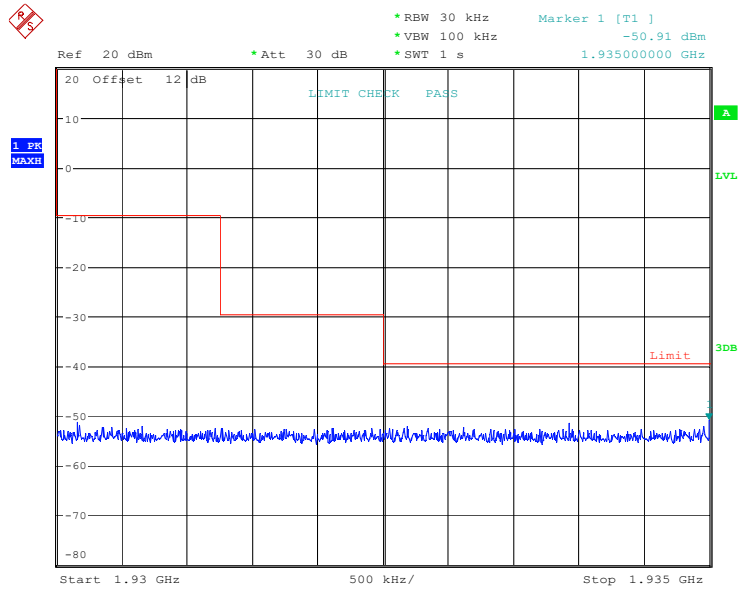

ProjectNo.:SZGMA231215-75845E-RF Tester:Hanic Pan
Date: 25.JAN.2024 15:51:46

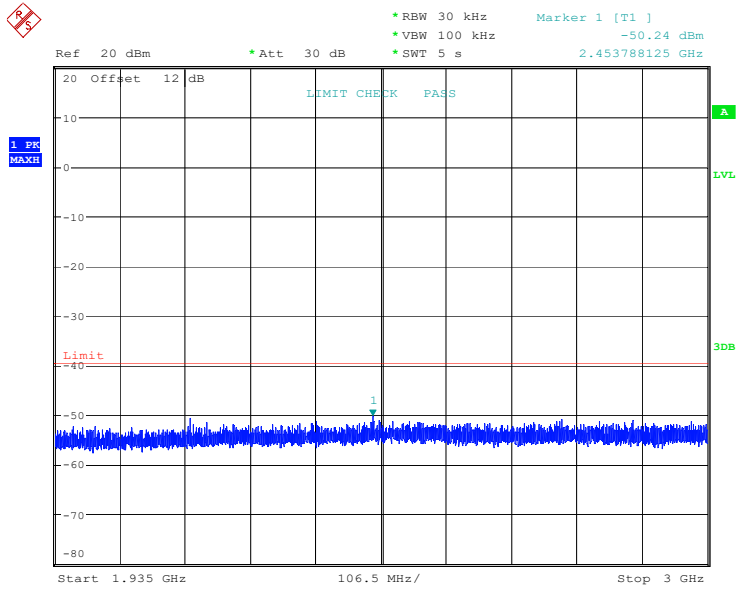

ProjectNo.:SZGMA231215-75845E-RF Tester:Hanic Pan
Date: 25.JAN.2024 15:52:28

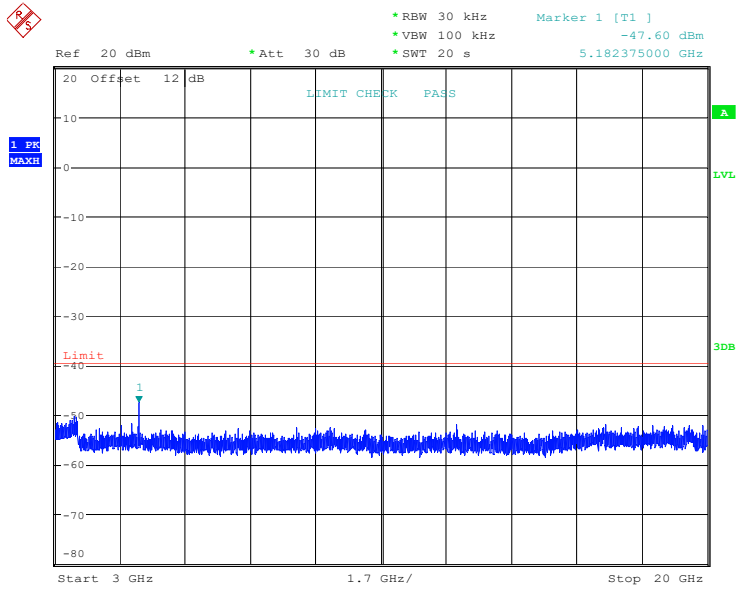

ProjectNo.:SZGMA231215-75845E-RF Tester:Hanic Pan
Date: 25.JAN.2024 15:53:30

Middle Channel (Unwanted Emission outside the Sub-band)

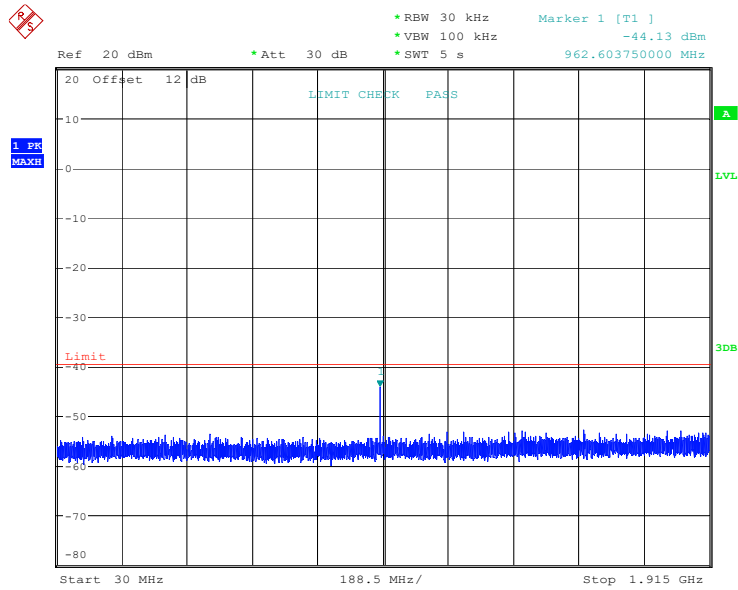

ProjectNo.:SZGMA231215-75845E-RF Tester:Hanic Pan
Date: 25.JAN.2024 16:26:38

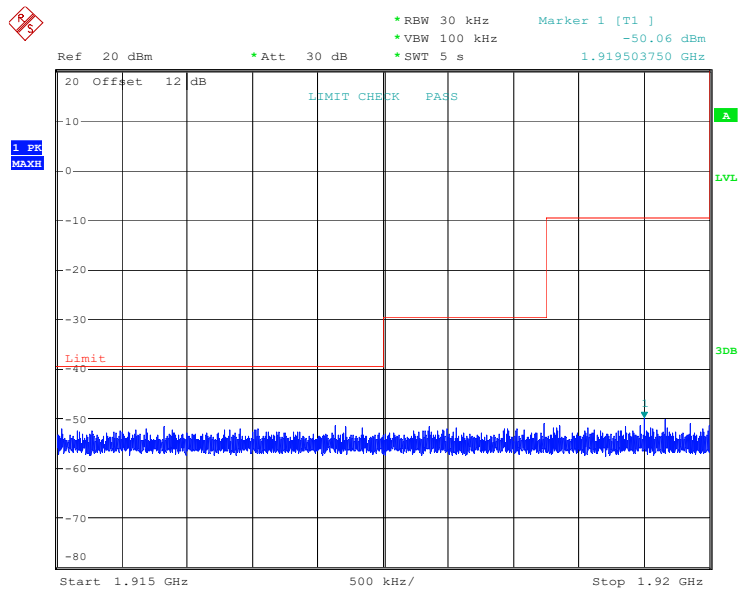

ProjectNo.:SZGMA231215-75845E-RF Tester:Hanic Pan
Date: 25.JAN.2024 16:27:20

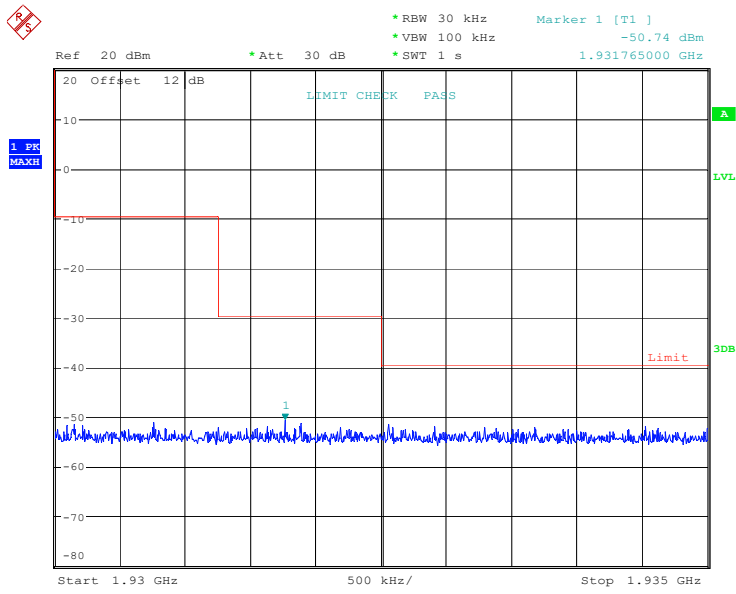

ProjectNo.:SZGMA231215-75845E-RF Tester:Hanic Pan
Date: 25.JAN.2024 16:27:56

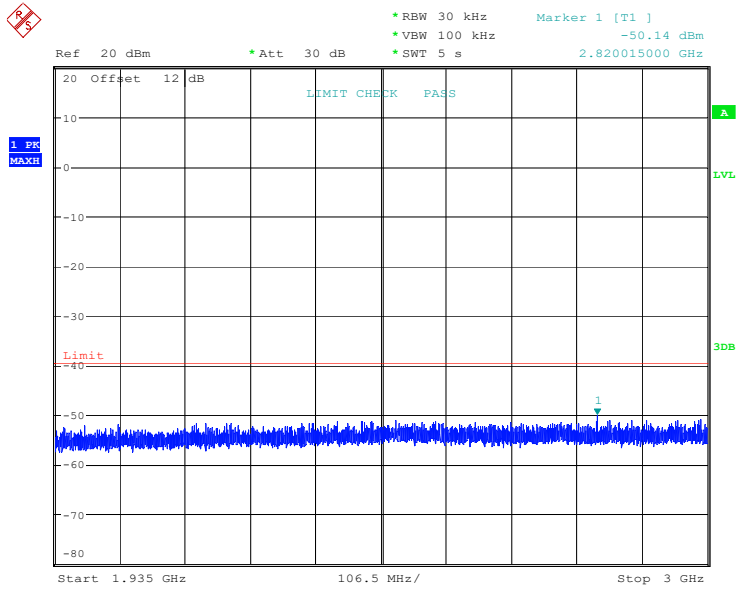

ProjectNo.:SZGMA231215-75845E-RF Tester:Hanic Pan
Date: 25.JAN.2024 16:28:37

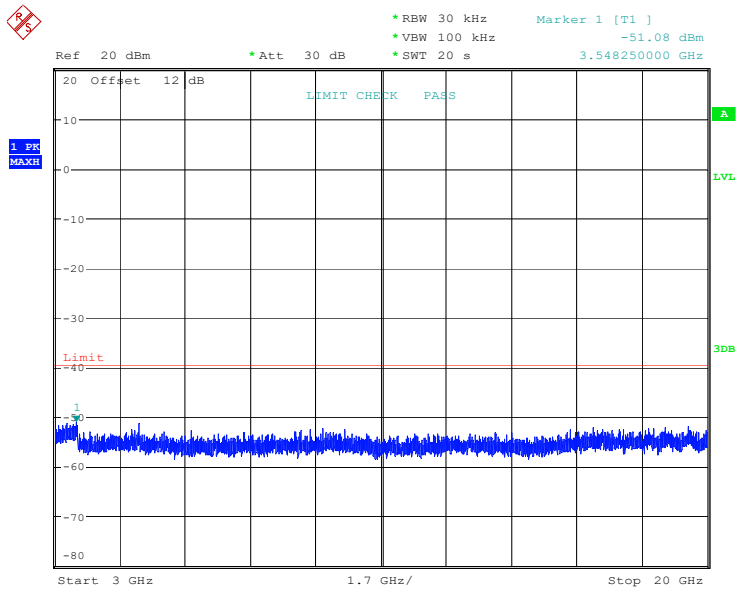

ProjectNo.:SZGMA231215-75845E-RF Tester:Hanic Pan
Date: 25.JAN.2024 16:29:40

High Channel (Unwanted Emission outside the Sub-band)

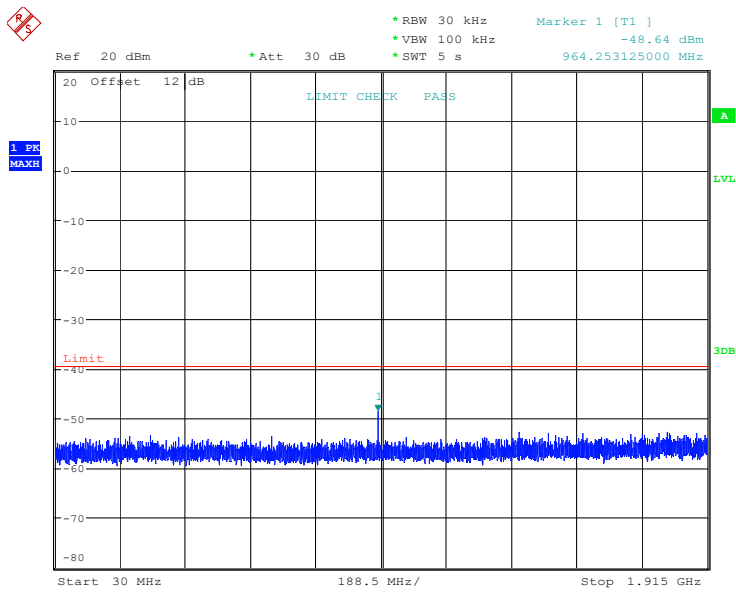

ProjectNo.:SZGMA231215-75845E-RF Tester:Hanic Pan
Date: 25.JAN.2024 16:33:09

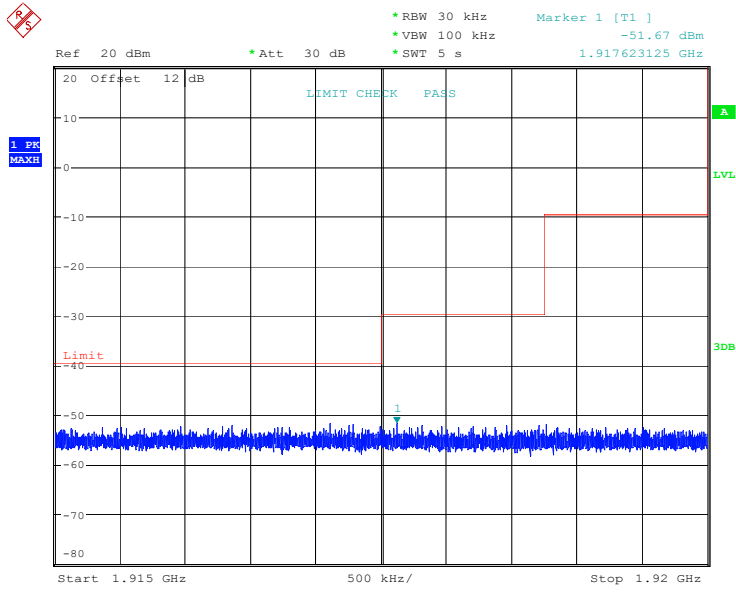

ProjectNo.:SZGMA231215-75845E-RF Tester:Hanic Pan
Date: 25.JAN.2024 16:33:51

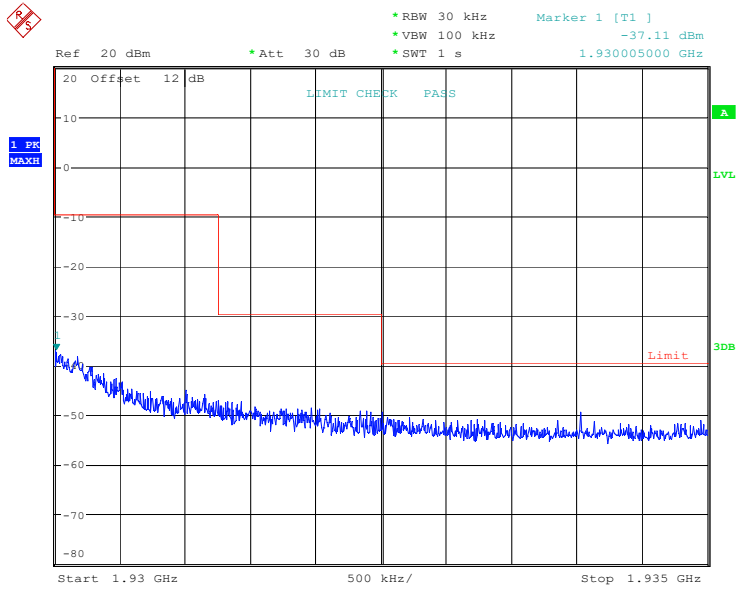

ProjectNo.:SZGMA231215-75845E-RF Tester:Hanic Pan
Date: 25.JAN.2024 16:34:27

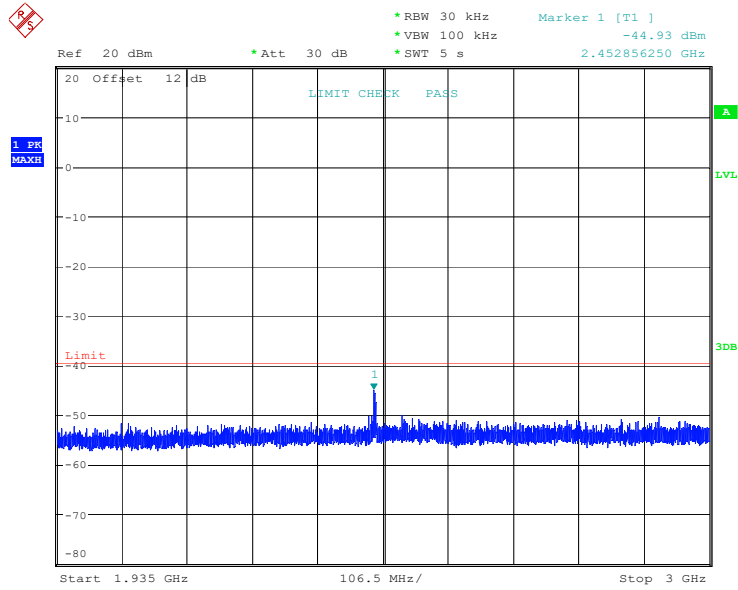

ProjectNo.:SZGMA231215-75845E-RF Tester:Hanic Pan
Date: 25.JAN.2024 16:35:08

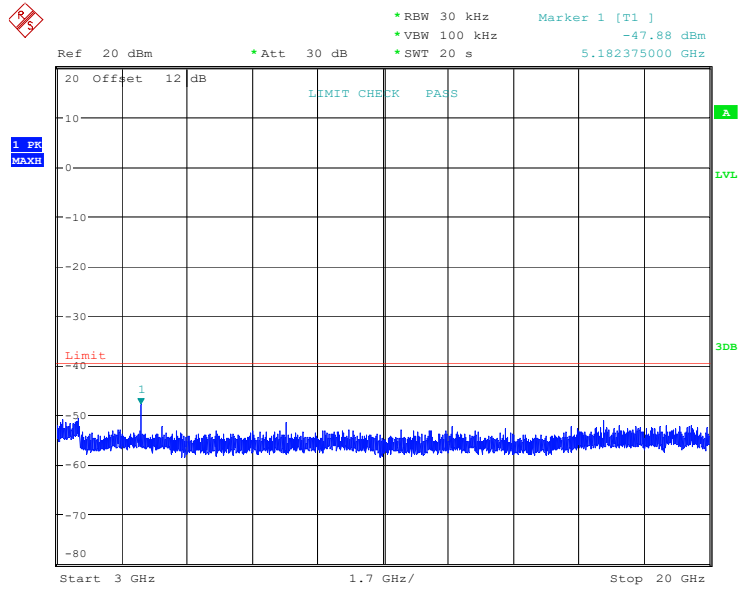

ProjectNo.:SZGMA231215-75845E-RF Tester:Hanic Pan
Date: 25.JAN.2024 16:36:11

FCC§15.323 (f) - FREQUENCY STABILITY

Applicable Standard

Per §15.323(f), the frequency stability of the carrier frequency of the intentional radiator shall be maintained within ± 10 ppm over 1 hour or the interval between channel access monitoring, whichever is shorter. The frequency stability shall be maintained over a temperature variation of -20°C to $+50^{\circ}\text{C}$ at normal supply voltage, and over a variation in the primary supply voltage of 85 percent to 115 percent of the rated supply voltage at a temperature of 20°C . For equipment that is capable only of operating from a battery, the frequency stability tests shall be performed using a new battery without any further requirement to vary supply voltage

Test Procedure

This procedure should be carried out for each of the following test cases:

Temperature	Supply Voltage
20°C	85-115% or new batteries
-20°C	Normal
+50°C	Normal

During test, the equipment shall be placed in the boxes and set the temperature to the specified requirement until the thermal balance has been reached.

Using the mean carrier frequency at 20°C and at nominal supply voltage as the reference, the mean carrier frequency shall be maintained within ± 10 ppm at the two extreme temperatures (or as declared by the manufacturer) and at normal temperature (typically 20°C) at the two extreme supply voltages. This test does not apply to a EUT that is capable only of operating from a battery.

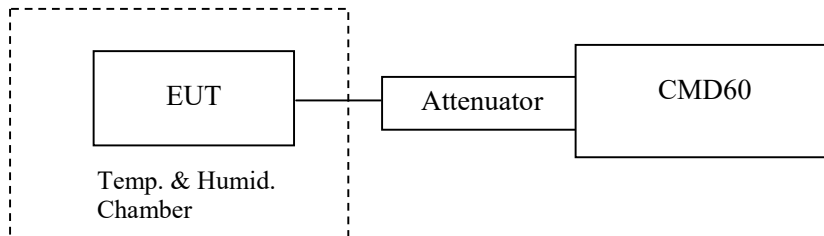

Test Data

Environmental Conditions

Temperature:	25~26 °C
Relative Humidity:	45~46 %
ATM Pressure:	101 kPa

The testing was performed by Hanic Pan on 2024-01-25.

Test mode: Transmitting

Test Result: Compliant

Temperature (°C)	Voltage (V _{AC})	Channel Frequency (MHz)	Measured Frequency Offset (kHz)	Measured Frequency Offset (ppm)	Limit (ppm)
-20	120	1924.992	1.33	0.69	±10
20	102	1924.992	1.89	0.98	±10
	138	1924.992	1.58	0.82	±10
50	120	1924.992	2.68	1.39	±10

FCC§15.323 (c) (e) & §15.319(f) – SPECIFIC REQUIREMENTS FOR UPCS DEVICE

Applicable Standard

FCC§15.323(c)(e) & §15.319(f) Specific Requirements for UPCS device.
 ANSI C63.17 2013 §6.2 Frequency and time stability and §7.Monitoring tests and §8.Time and spectrum window access procedure.

Test Procedure

Measurement method according to ANSI C63.17 -2013

Test configuration as below

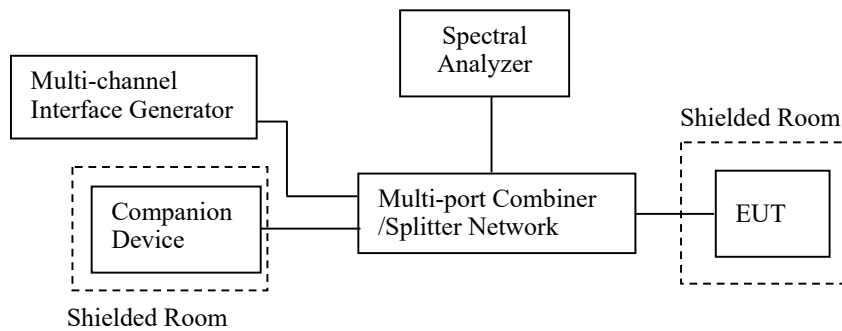

Test Data

Environmental Conditions

Temperature:	25~26 °C
Relative Humidity:	45~46 %
ATM Pressure:	101 kPa

The testing was performed by Hanic Pan on 2024-01-25.

Test Result: Compliant, please see the below data

1) Automatic Discontinuation of Transmission

Test result:

The following tests were performed after a connection had been established with Handset unit.

Test condition	Reaction of EUT	Pass/Fail
Adapter removed from EUT	Connection break down	Pass
Battery remove from Handset	Connection break down	Pass

2) Monitoring Time

Test result:

This requirement is covered by the results of Least Interfered Channel (LIC).

Interference (Refer to ANSI C63.17 clause 7.3.3)	Reaction of EUT	Results
a) Apply the interference on f_1 at level $T_L+U_M+20\text{dB}$ and no interference on f_2 . Initiate transmission and verify the transmission only on f_2 . Then terminate it.	EUT transmits on f_2	Pass
b) Apply the interference on f_2 at level $T_L+U_M+20\text{dB}$ and immediately remove all interference from f_1 . The EUT should immediately attempt transmission on f_1 (but at least 20 ms after the interference on f_2 is applied), verify the transmission only on f_1 .	EUT transmission f_1	Pass

3) Lower Monitoring Threshold

Test result:

Not applicable because the EUT has more 40 defined duplex system access channels and meet the provision of the Least Interfered Channel (LIC).

4) Maximum Transmit Period

Test result:

Repetition of Access Criteria	Measured Maximum Transmission Time (Second)	Limit (Second)	Results
First	18350	28,800	Pass
Second	18350	28,800	Pass

5) System Acknowledgement

Test result:

Test	Time taken (second)	Limit (second)	Result
Initial Connection acknowledgement	0.39	1	Pass
Change of access criteria for control information	N/A	30	N/A
Transmission cease time	4.16	30	Pass

Note: N/A=Not Applicable

6) Least Interfered Channel (LIC)

Calculation of monitoring threshold limits for isochroous devices:

Lower threshold: $TL = -174 + 10\log_{10}B + ML + P_{MAX} - P_{EUT}$ (dBm)

Where: B=Emission bandwidth (Hz)

ML = dB the threshold may exceed thermal noise (30 for T_L)

$P_{MAX} = 5\log_{10}B - 10$ (dBm)

P_{EUT} = Transmitted power (dBm)

Calculated thresholds:

Monitor Threshold	B(MHz)	M_L (dB)	P_{MAX} (dBm)	P_{EUT} (dBm)	Threshold (dBm)
Lower threshold	1.466	30	20.83	20.6	-82.11

Note: 1. The upper threshold is applicable as the EUT utilizes more than 20 duplex system channels

Test result:

LIC procedure test:

Interference (Refer to ANSI C63.17 clause 7.3.3)	Reaction of EUT	Results
a) Apply the interference on f_1 at level $T_L + U_M + 7$ dB and the interference on f_2 at level $T_L + U_M$. Initiate transmission and verify the transmission only on f_2 . Repeat 5 times.	EUT transmits on f_2	Pass

b) Apply the interference on f_1 at level T_L+U_M and the interference on f_2 at level $T_L+U_M+7\text{dB}$. Initiate transmission and verify the transmission only on f_1 . Repeat 5 times.	EUT transmits on f_1	Pass
c) Apply the interference on f_1 at level $T_L+U_M+1\text{dB}$ the interference on f_2 at level $T_L+U_M-6\text{dB}$. Initiate transmission and verify the transmission only on f_2 . Repeat 5 times.	EUT transmits on f_2	Pass
d) Apply the interference on f_1 at level $T_L+U_M-6\text{dB}$ and the interference on f_2 at level $T_L+U_M+1\text{dB}$. Initiate transmission and verify the transmission only on f_1 . Repeat 5 times.	EUT transmits on f_1	Pass

Selected channel confirmation:

Interference (Refer to ANSI C63.17 clause 7.3.4)	Reaction of EUT	Results
a) Apply the interference on f_1 at level T_U+U_M and no interference on f_2 . Initiate transmission and verify the transmission only on f_2 . Then terminate it.	EUT transmits on f_2	Pass
b) Apply the interference on f_2 at level T_L+U_M and immediately remove all interference from f_1 . The EUT should immediately attempt transmission on f_1 (but at least 20 ms after the interference on f_2 is applied), verify the transmission only on f_1 .	EUT transmission f_1	Pass

7) Random waiting

Note: This is Not Applicable

8) Monitoring Bandwidth and Reaction Time

Test result:

Monitoring Bandwidth:

The antenna of the EUT used for monitoring is the same interior antenna that used for transmission, so the monitoring system bandwidth is equal to the emission bandwidth of the intended transmission

Reaction Time Test:

No.	Interference Pulse width (μs)	Reaction of EUT	Observing time (μs)	Result
1	50μs with level T_L+U_M	No transmission	26.45	Pass
2	35μs with level T_L+U_M+6dB	No transmission	22.05	Pass

9) Monitoring Antenna

Test result:

The antenna of the EUT used for transmission is the same interior antenna that used for monitoring.

10) Monitoring threshold relaxation

Test result:

This requirement is covered by the results of Least Interfered Channel (LIC).

11) Duplex Connections

Test result:

Interference (Refer to ANSI C63.17 § 8.3& § 8.3.2)	Reaction of EUT	Results
a) Only a single carrier f_1 for EUT TDMA systems and on f_1 and f_2 and corresponding duplex carriers for FDMA systems.	EUT can transmit	Pass
b) All Tx windows with level T_L+U_M except one & Rx windows with level T_L+U_M+7dB except one, which are not the duplex mate.	Connected on the target Rx window and its duplex mate.	Pass
c) All Tx windows with level T_L+U_M+7dB except one & Rx windows with level T_L+U_M except one, which are not duplex mate.	Connected on the target Tx window and its duplex mate.	Pass
d) All Tx & Rx windows with level T_U+U_M , except one for Tx window & one for Rx window, which are not duplex mate.	No connection possible	Pass

12) Alternative monitoring interval

Test result:

Interference (Refer to ANSI C63.17 § 8.4)	Reaction of EUT	Results
a) Only a single carrier f_1 for EUT TDMA systems and on f_1 and f_2 and corresponding duplex carriers for FDMA systems.	EUT can transmit	Pass
b) Apply interference with same parameters as EUT transmissions on all Tx windows with level TL+UM on the enabled carrier(s) and no interference on the Rx windows on the enabled carriers.	No connection is established	Pass

13) Fair Access

Test result:

The manufacturer declares that this device does not use any mechanisms as provided by FCC §15.323(c)(10) or (11) & IC RSS-213 5.2(10) and (11) to extend the range of spectrum occupied over space or time for the purpose of denying fair access to spectrum to other device.

14) Frame Repetition Stability Frame Period and Jitter

Test result:

Frame Period and Jitter:

Max. pos. Jitter (µs)	Max. neg. Jitter (µs)	Frame period (ms)	Limit	
			Frame Period (ms)	Jitter (µs)
0.04	-0.04	10.05	20 or 10/X	25

Note: X is a positive whole number.

EUT PHOTOGRAPHS

Please refer to the attachment SZGMA231215-75845E-RF-FP External photo and SZGMA231215-75845E-RF-FP Internal photo.

TEST SETUP PHOTOGRAPHS

Please refer to the attachment SZGMA231215-75845E-RF-FP Test Setup photo.

******* END OF REPORT *******