



Li Time

LiFePO4

12V 50Ah

Smart  **X** **Trolling Motor**
BLUETOOTH 5.0 and More

PRODUCT (50A BMS)

MANUAL

Lithium Iron Phosphate Battery(LiFePO4)

PRODUCT OVERVIEW

12V 50AH BATTERY

Operating Voltage: 12.8V

Charging Voltage: $14.4V \pm 0.2V$

Recommended Charge Current: 10A (0.2C)

Max. Continuous Discharge Current: 50A

Max. Continuous Load Power: 640W

Max. Thrust Power: 70lbs

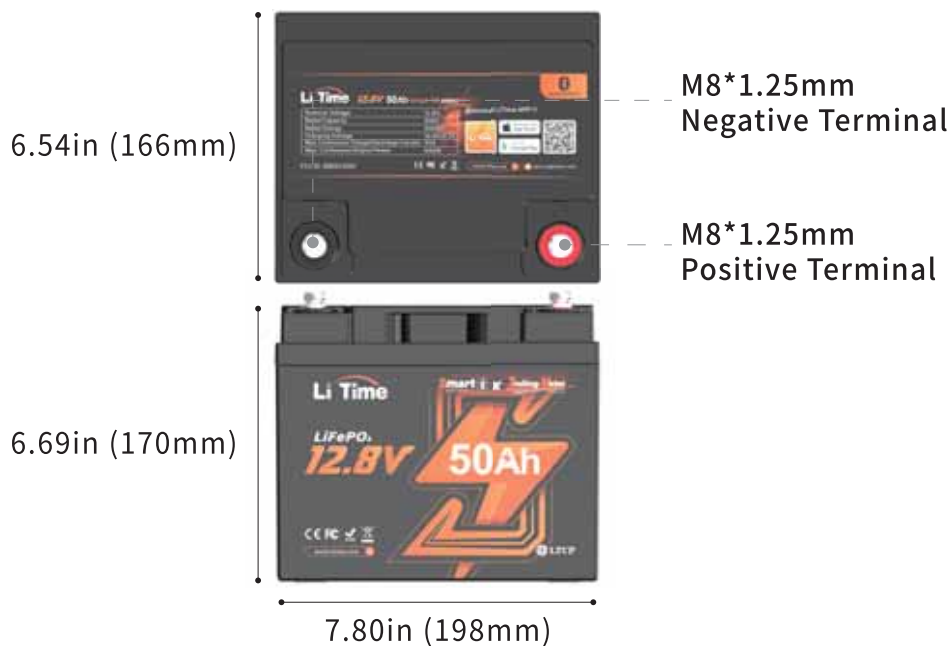

ADDITIONAL COMPONENTS

M8- 35/64" (14mm) Terminal Bolts

The terminal bolts are used to secure multiple cable lugs to a single battery terminal. The bolts can be replaced with M8 bolts of other lengths based on actual needs.

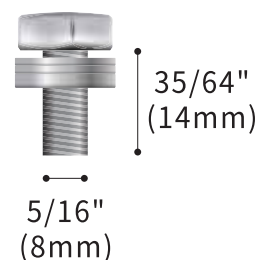

Insulating Caps for Bolts

24/7 MONITORING VIA LITIME APP

The LiTime 12V 50Ah Smart TM LiFePO4 battery, integrated with Bluetooth 5.0, enables accurate and effortless real-time tracking and management of the battery status.

Step
1

Download the LiTime APP and register your account.

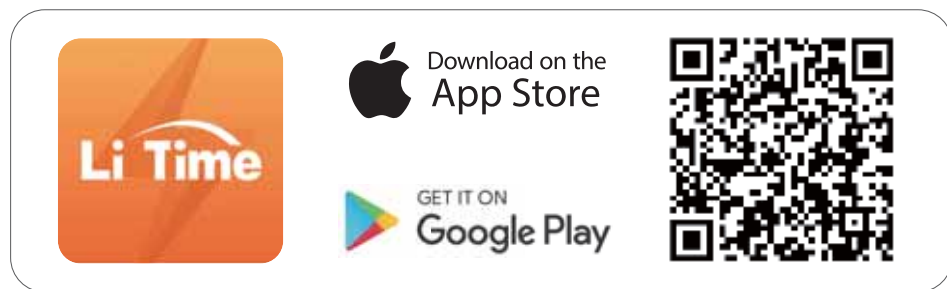

Step
2

Pair the battery with the LiTime APP and effortlessly keep track of the battery's real-time status.

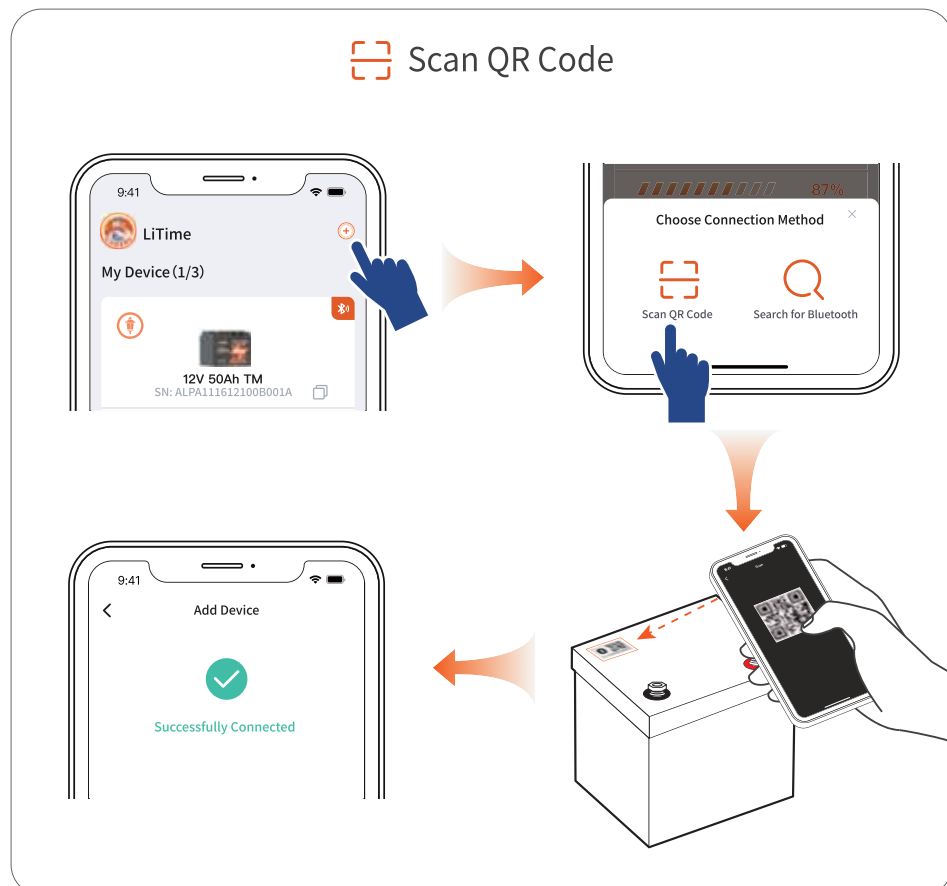

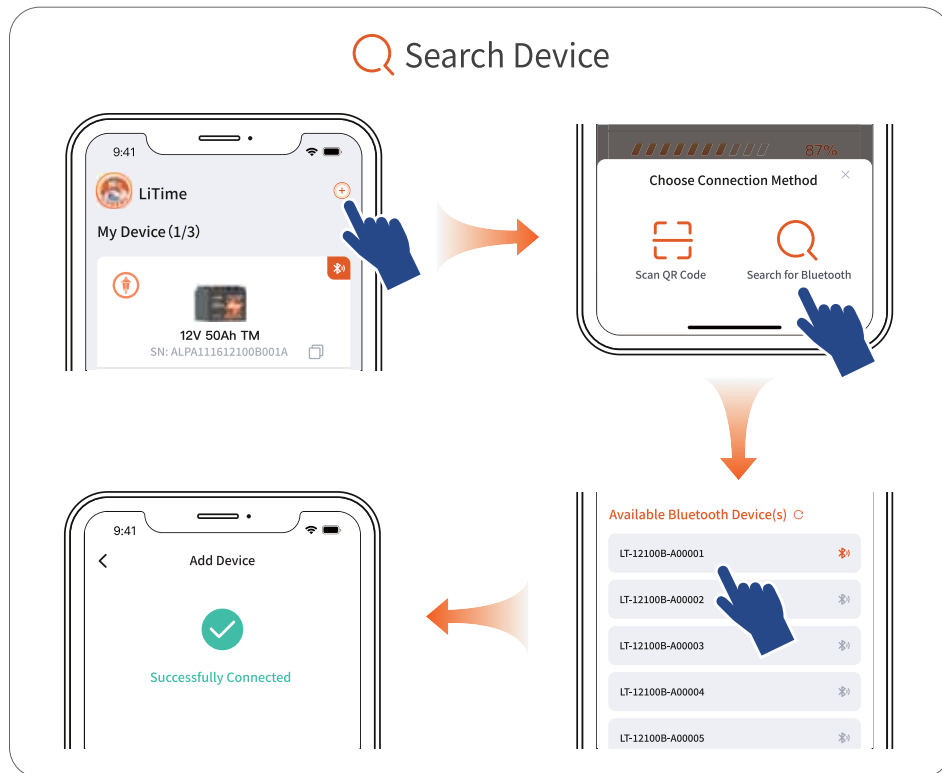

FCC STATEMENT

This device complies with Part 15 of the FCC Rules. Operation is subject to the following two conditions:

- This device may not cause harmful interference.
- This device must accept any interference received, including interference that may cause undesired operation.

This device has been tested and found to comply with the limits for a Class B digital device, pursuant to Part 15 of the FCC Rules. These limits are designed to provide reasonable protection against harmful interference in a residential installation. This device generates, uses, and can radiate radio frequency energy and, if not installed and used in accordance with the instructions, may cause harmful interference to radio communications. However, there is no guarantee that interference will not occur in a particular installation. If this device does cause harmful interference to radio or television reception, which can be determined by turning the equipment off and on, the user is encouraged to try to correct the interference by one or more of the following measures:

- Orient or relocate the receiving antenna.
- Increase the separation between the equipment and receiver.
- Connect the equipment into an outlet on a circuit different from that to which the receiver is connected.
- Consult the dealer or an experienced radio/TV technician for help.

RF Exposure Information: This equipment complies with FCC radiation exposure limits set forth for an uncontrolled environment. This equipment should be installed and operated with minimum distance 20cm between the radiator and your body.

Caution: Any changes or modifications to this device not explicitly approved by manufacturer could void your authority to operate this equipment.

IMPORTANT SAFETY INSTRUCTION

■ Please keep the battery away from heat sources, sparks, flames, and hazardous chemicals.

■ Maintain Adequate Ventilation and Heat Dissipation

Place the battery in a well-ventilated area with sufficient heat dissipation to prevent overheating and damage.

■ Size the Battery Cables and Connectors Appropriately

Use high-stranded copper connectors and heavy gauge cables to handle possible battery loads. Make sure to keep identical cable lengths.

Avoid accidents caused by unsuitable connectors or cables that make the connection a heat source during battery operation.

■ Please tighten all cable connections, as loose cable connections can cause terminal meltdown or fire.

■ DO NOT puncture, drop, crush, burn, penetrate, shake, or strike the battery.

The battery should be securely fastened during handling to prevent impact or dropping.

It should be safely secured to a solid plane and the cables safely tied to a suitable location to avoid arcing and sparking due to friction.

DO NOT press it by placing heavy stuff on top of it for long periods, which may damage it due to an internal short circuit.

■ DO NOT immerse the battery in water whether the battery is in use or on standby.

■ DO NOT open, dismantle, or modify the battery.

■ DO NOT touch the exposed electrolyte or powder if the battery casing is damaged.

■ Uncovered electrolyte or powder that has contacted the skin or eyes MUST be flushed out with plenty of clean water immediately. Seek medical attention afterward.

■ Avoid Short Circuit

Please use circuit breakers, fuses, or disconnects that have been properly sized by certified electricians, licensed installers, or regional code authorities to protect all the electrical equipment in your system. The battery has a built-in battery management system (BMS) that protects the battery cells from over-charge, over-discharge, and over-current, however this alone will not protect your system from severe electrical conditions.

BATTERY PARAMETERS

| | |
|---------------------------------------|--------------------------------|
| Cell Type | LiFePO4 |
| Nominal Voltage | 12.8V |
| Rated Capacity | 50Ah |
| Energy | 640Wh |
| Internal Resistance | $\leq 40\text{m}\Omega$ |
| Cycle Life | ≥ 4000 times |
| Battery Management System (BMS) Board | 50A |
| Charge Method | CC/CV |
| Charge Voltage | $14.4\text{V} \pm 0.2\text{V}$ |
| Recommended Charge Current | 10A (0.2C) |
| Max. Continuous Charge Current | 50A |
| Max. Continuous Discharge Current | 50A |
| | 60A@30mins |
| Surge Discharge Current | 250A@1 second |

| | |
|--|--|
| Max. Continuous Output Power | 640W |
| Max.Thrust Power | 70lbs ^① |
| Dimension | L7.80*W6.54*H6.69 inch |
| | L198*W166*H170 mm |
| Housing Material | ABS (Flame Retardant Plastic) |
| Recommended Terminal Torque | 106.2 to 123.9 inch · lbs / 12 to 14 N · m |
| Protection Class | IP65 |
| Temperature Range | Charge: 0°C to 50°C / 32°F to 122°F |
| | Discharge: -20°C to 60°C / -4°F to 140°F |
| | Storage: -10°C to 50°C / 14°F to 122°F |
| Low Temperature Charging Protection (LTCP) Function ^② | Yes |
| Resume Charging Temperature Under LTCP | 5°C/41°F (Battery Temperature) |
| FCC ID | 2BDSV1250 |

① One 12V 50Ah Smart TM battery with Bluetooth is suitable for 12V trolling motors up to 70 lbs thrust; 2*identical batteries in series for 24V trolling motors up to 100 lbs thrust; 3*identical batteries in series for 36V trolling motors up to 120 lbs thrust.

② The 12V 50Ah Smart TM battery with Bluetooth supports Low Temperature Charge Protection(LTCP), where the BMS stops battery charging when the battery temperature falls below 0°C/32°F and resumes charging when the temperature rises above 5°C/41°F.

CHARGING METHODS

SOLAR PANEL(S) & CONTROLLER

Solar Panel

☆ Recommended Power: $\geq 200W$

- The battery can be fully charged in one day (with effective sunshine 4.5hrs/day) by 200W solar panels.
- It may take more than one day to fully charge the battery by $\geq 200W$ solar panels since the duration and intensity of light would be a great factor for their charging efficiency.

Controller

☆ Recommended Charging Current:

| | |
|------------|--|
| 10A (0.2C) | The battery will be fully charged in around 5hrs to 100% capacity. |
| 25A (0.5C) | The battery will be fully charged in around 2hrs to around 97% capacity. |

☆ Recommended Charging Mode: **12V (14.6V) LI (LiFePO4)**

Controller Settings

Refer to the below parameters if you need to manually set up your controller. As different types of batteries have different charging modes, **it is recommended to set only the following parameters for LiFePO4 batteries.** The settings for other types of batteries do not apply to LiFePO4 batteries except for the following settings.

| | | |
|---------------------|-----------------------------|-----------------|
| CHARGING | Charge /Bulk /Boost Voltage | 14.4 \pm 0.2V |
| | Absorption Voltage | 14.4 \pm 0.2V |
| | Over Voltage Disconnect | 15V |
| | Over Voltage Reconnect | 14.2V |
| | Tail Current | 1A (0.02C) |
| DIS-CHARGING | Under Voltage Warning | 11.6V |
| | Under Voltage Recover | 12V |
| | Low Voltage Disconnect | 10.8V |
| | Low Voltage Reconnect | 12.4V |

BATTERY CHARGER

Use 14.6V lithium iron phosphate (LiFePO₄) battery charger to maximize the capacity.

☆ Recommended Charging Voltage: Between 14.2V to 14.6V

☆ Recommended Charging Current:

| | |
|------------|--|
| 10A (0.2C) | The battery will be fully charged in around 5hrs to 100% capacity. |
| 25A (0.5C) | The battery will be fully charged in around 2hrs to around 97% capacity. |

Tips

① It's recommended to disconnect the charger from the battery after fully charging.

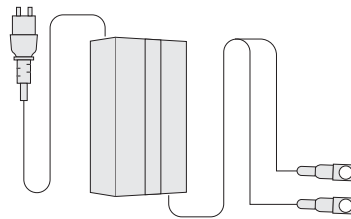

ALTERNATOR / GENERATOR

LiTime battery can be charged by an alternator or generator.

If the alternator/generator **supports DC output**, a **DC-to-DC charger** needs to be added between the battery and the generator; if the alternator/generator **supports AC output**, please refer to the recommendations in "Battery Charger" above to add a **suitable battery charger** between the battery and the generator.

☆ Recommended Charging Voltage: Between 14.2V to 14.6V

☆ Recommended Charging Current:

| | |
|------------|--|
| 10A (0.2C) | The battery will be fully charged in around 5hrs to 100% capacity. |
| 25A (0.5C) | The battery will be fully charged in around 2hrs to around 97% capacity. |

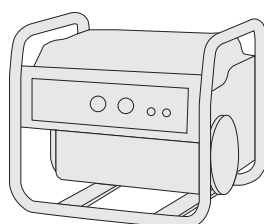

HOW TO CONNECT BATTERIES

Step1 Wear Insulating Gloves

Wear insulating gloves for protection before connecting. Please pay attention to operation safety in the process of connection.

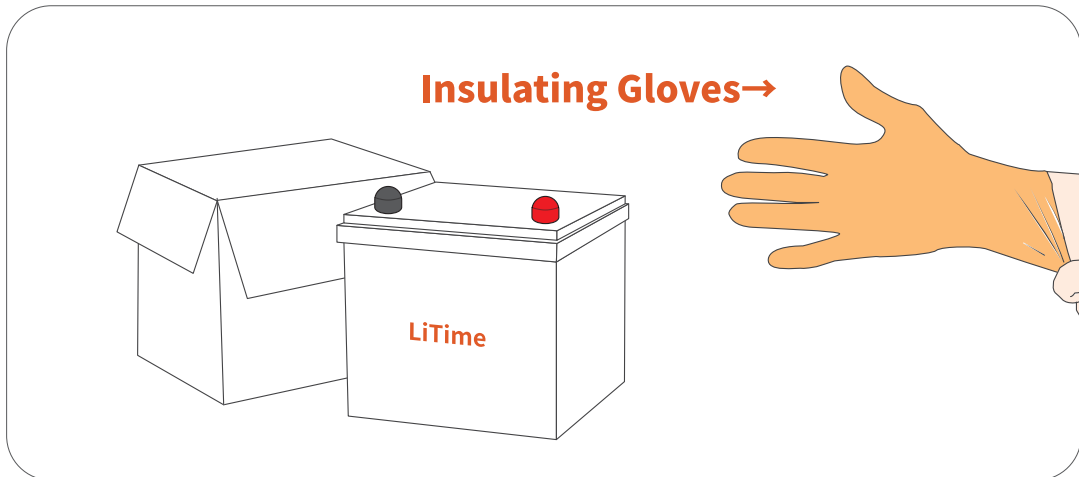

Step2 Voltage Balancing Before Connection

Below two steps are necessary to reduce the voltage difference between batteries and let the battery system perform the best of it in series or/ and in parallel.

Step
1

Fully charge the batteries separately.
(voltage at rest: $\geq 13.33V$)

Step
2

Connect all of the batteries in parallel, and leave them together for 12~24hrs.

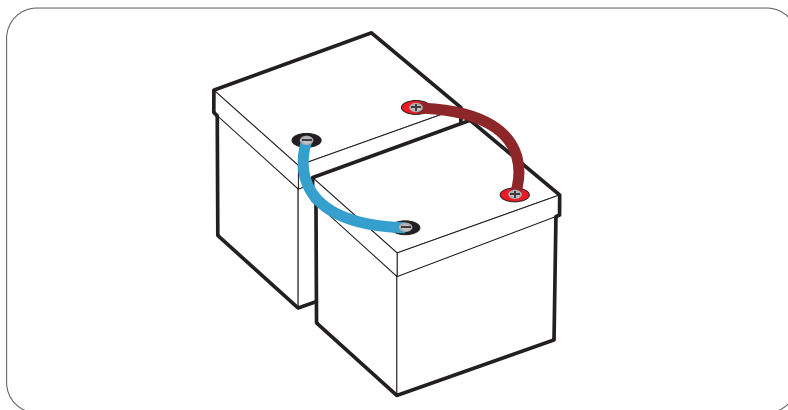

Step
3

They' re now ready for the connection.

Step 3 Battery-to-Battery Connection

○ #1 Connect Batteries in Series

+ to **-**

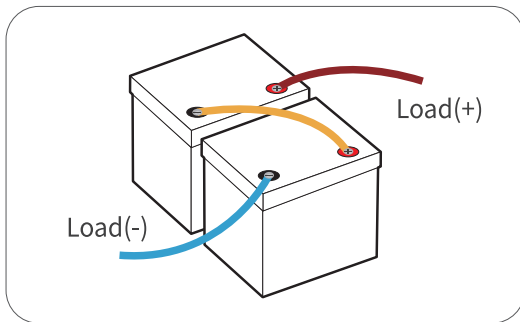

After series connection, the **voltage** of the battery system will be doubled according to the number of batteries you connect.

E.g. If two 12V 50Ah TM batteries are connected in series, the battery system will be 24V (25.6V) 50Ah.

○ #2 Connect Batteries in Parallel

+ to **+**

- to **-**

Refer to Page 11 for total input & output connection

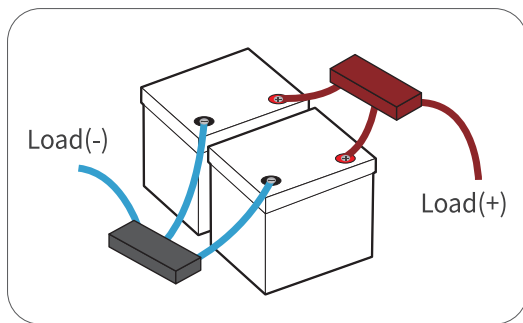

After parallel connection, the **capacity** of the battery system will be doubled according to the number of batteries you connect.

E.g. If two 12V 50Ah TM batteries are connected in parallel, the battery system will be 12V (12.8V) 100Ah.

○ #3 Connect Batteries Both in Series & Parallel

Connect in parallel first, then series.

Step
1

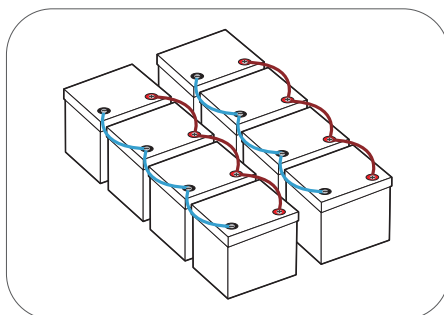

Connect the batteries in **parallel**.

Step
2

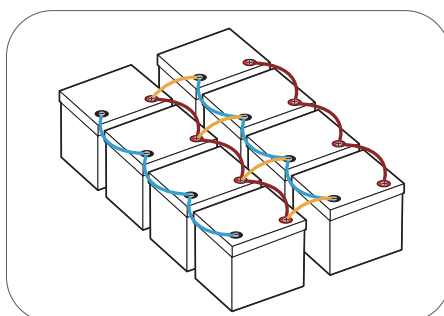

Connect the paralleled battery systems in **series**.

Step 4 Total Input & Output Connection

Use two **copper bars** (instead of battery terminals) to connect all the positive and negative output/input cables, ensuring that the input & output currents of each battery are balanced. (Not required when connecting batteries only in series.)

It is not recommended to use one terminal as the total positive or negative output/input of the battery system as the connected terminals may heat up or even melt if the total output/input current of the battery system is too high.

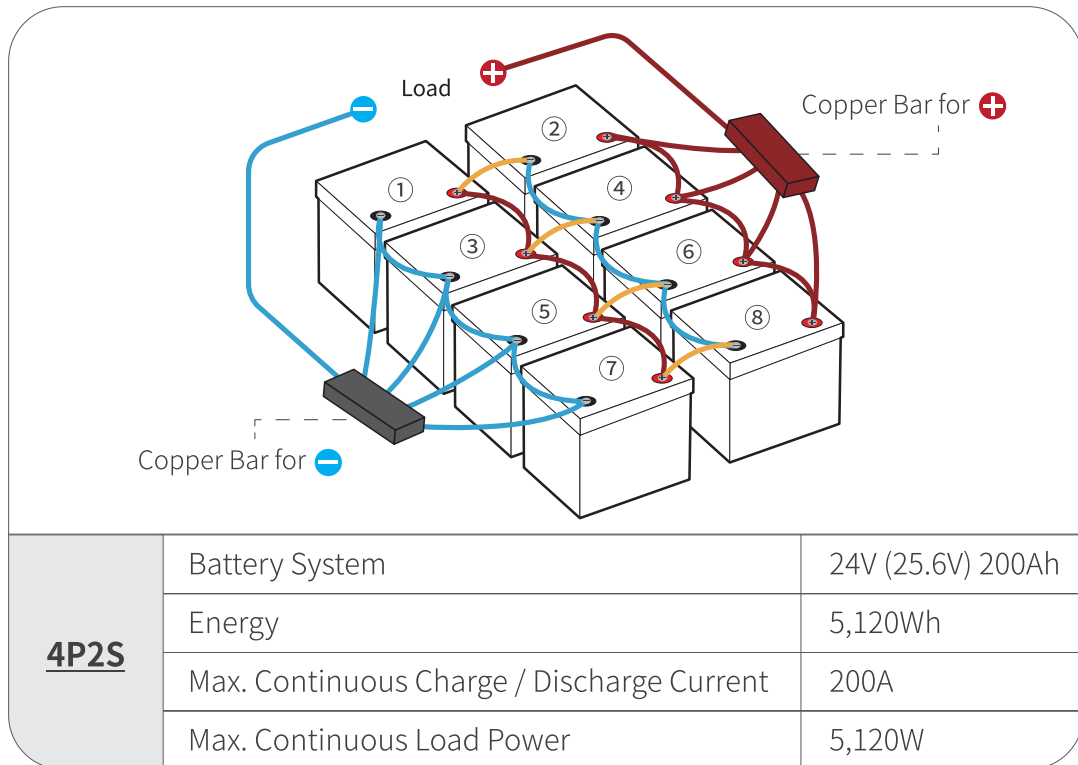

① As **+** of ① / ③ / ⑤ / ⑦ is connected in series with **-** of ② / ④ / ⑥ / ⑧, please do not connect **+** of ① / ③ / ⑤ / ⑦ with **+** of load or **-** of ② / ④ / ⑥ / ⑧ with **-** of load, otherwise the battery system will fail to connect in series.

② Please do not connect in reverse order, which may affect the use of the batteries.

Step 5 Rebalancing Every 6 Months

It is recommended to rebalance the battery voltage every six months following Step 2 on Page 9 if you're connecting multiple batteries as a battery system, as there might be voltage differences after six months of the battery system running.

