

交流充电桩使用说明书

Operation Instruction of AC Charging Pile

— ZYJ22-X-32A/220V-JT

目录

Contents

目录.....	- 1 -
Contents.....	- 1 -
前言.....	- 3 -
Foreword.....	- 3 -
安全注意事项.....	- 3 -
Safety Precautions.....	- 3 -
第 1 章 产品介绍.....	- 5 -
Chapter 1 Product Introduction.....	- 5 -
1.1 产品简介.....	- 5 -
1.1 Product Introduction.....	- 5 -
1.2 产品原理框图.....	- 6 -
1.2 Product Functional Block Diagram.....	- 6 -
1.3 主要参数说明.....	- 7 -
1.3 Description of Main Parameters.....	- 7 -
1.4 产品性能与特点.....	- 8 -
1.4 Product Performance and Features.....	- 8 -
1.5 产品使用环境.....	- 9 -
1.5 Operating Environment of Product.....	- 9 -
1.6 产品设计规范.....	- 10 -
1.6 Design Specifications of Products.....	- 10 -
1.7 产品结构.....	- 12 -
1.7 Product Structure.....	- 12 -
1.7.1 整体外形图.....	- 12 -
1.7.1 Outside View.....	- 12 -
1.7.2 内部结构图.....	- 12 -
1.7.2 Internal Structure Diagram.....	- 12 -
第 2 章 安装操作说明.....	- 12 -

Chapter 2 Instructions for Installation and Operation	- 12 -
2.1 开箱检查	- 12 -
2.1 Open-box Inspection	- 12 -
2.2 安装准备	- 13 -
2.2Preparation for Installation	- 13 -
2.3 安装流程	- 15 -
2.3 Installation Process	- 15 -
2.4 设备上电检查、调试	- 17 -
2.4 Power-on Inspection and Debugging of Equipment	- 17 -
2.5 充电操作	- 19 -
2.5 Charging Operation	- 19 -
2.6 远程充电控制	- 19 -
2.6 Remote Charging Control	- 19 -
第 3 章 常见故障处理	- 21 -
Chapter 3 Common Troubleshooting	- 24 -

前言

Foreword

感谢各位对本产品的支持，本公司专注新能源电动汽车充电领域，致力于为客户提供卓越的充电设备和完整的充电运营解决方案。

Thank you for your support for our products. Our company focuses on the field of new energy electric vehicle charging and is committed to providing customers with excellent charging equipment and complete charging operation solutions.

我司研发生产的电动汽车充电桩功能先进、性能稳定、使用范围广、实用性强，并具备成熟的充电站建设和运营解决方案，拥有良好的业界口碑。

The electric vehicle charging pile developed and produced by our company has advanced functions, stable performance, wide application of use, strong practicability, mature charging station construction and operation solutions, and has a good reputation in the industry.

安全注意事项

Safety Precautions

- 1) 请勿将易燃、易爆或可燃材料、化学物、可燃蒸汽等危险物品靠近充电桩；
- 1) Please do not put flammable, explosive or combustible materials, chemicals, combustible vapor and other dangerous goods near the charging pile;
- 2) 保持充电枪头清洁干燥，如有脏污，请用清洁的干布擦拭，严禁带电时用手触碰充电枪芯；
- 2) Keep the charging gun head clean and dry. If it is dirty, please wipe it with a clean dry cloth. It is strictly forbidden to touch the charging gun core with hands when it is live
- 3) 严禁在充电枪或充电线缆存在缺陷、裂痕、磨损、破裂、充电线缆裸露等情况下使用充电桩，如有发现，请及时联系工作人员；
- 3) It is strictly forbidden to use the charging pile when the charging gun or the charging cable is defective, cracked, worn, broken, or the charging cable is exposed. If any defect is found, please contact the staff in time;
- 4) 请勿试图拆卸、维修、改装充电桩，如有维修、改装需求，请联系工作人员，不正当的操作可能会造成设备损坏、漏水、漏电等情况；

- 4) Please do not try to dismantle, repair or modify the charging pile. If it is needed to repair or modify it, please contact the staff. Improper operation may cause damage, water leakage, and electric leakage to the equipment;
- 5) 使用过程中如有什么异常情况，可立即按下急停按钮，切断所有输入输出电源；
- 5) In case of any abnormal situation during the use, press the emergency stop button immediately to turn off all input and output power supplies;
- 6) 如遇下雨打雷天气，请谨慎充电；
- 6) In case of rain and thunder, please charge carefully;
- 7) 儿童请勿在充电过程中靠近、使用充电桩，以免造成伤害。
- 7) Children shall not get close to and use the charging pile during charging to avoid injury.
- 8) 在充电过程中，车辆禁止行驶，只有在静止时才能进行充电。混合动力电车请熄火后再进行充电。
- 8) In the process of charging, the vehicle is forbidden to drive and can be charged only when it is static. The hybrid electric vehicle shall flame out before charging.

第 1 章 产品介绍

Chapter 1 Product Introduction

1.1 产品简介

1.1 Product Introduction

本产品是单相交流充电桩，主要用于电动汽车交流慢充，产品设计高度简约，提供刷卡与即插即用充电方式，具充电保护等功能。设备采用工业化设计原则，独创倾倒防护功能，保证设备运行安全。整机防护等级达到 IP65，具有良好的防尘、防水功能，可在室外安全的运行和维护。

This product is a single-phase AC charging pile, mainly used for AC slow charging of electric vehicles. The design of the product is highly simple. It provides card swiping and plug and play charging modes, with charging protection function. The principle of industrial design is adopted for the equipment, with the original function of toppling protection to ensure safe operation of the equipment. The protection level of the whole equipment reaches IP65, and it has good dustproofing and waterproofing functions and can be safely operated and maintained outdoors.



图 1 充电桩外形图

Figure 1 Outside View of Charging Pile

1.2 产品原理框图

1.2 Product Functional Block Diagram

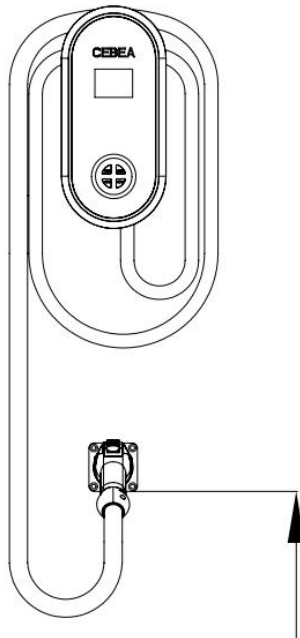

图2 产品原理框图

Figure 2 Product Functional Block Diagram

1.3 主要参数说明

1.3 Description of Main Parameters

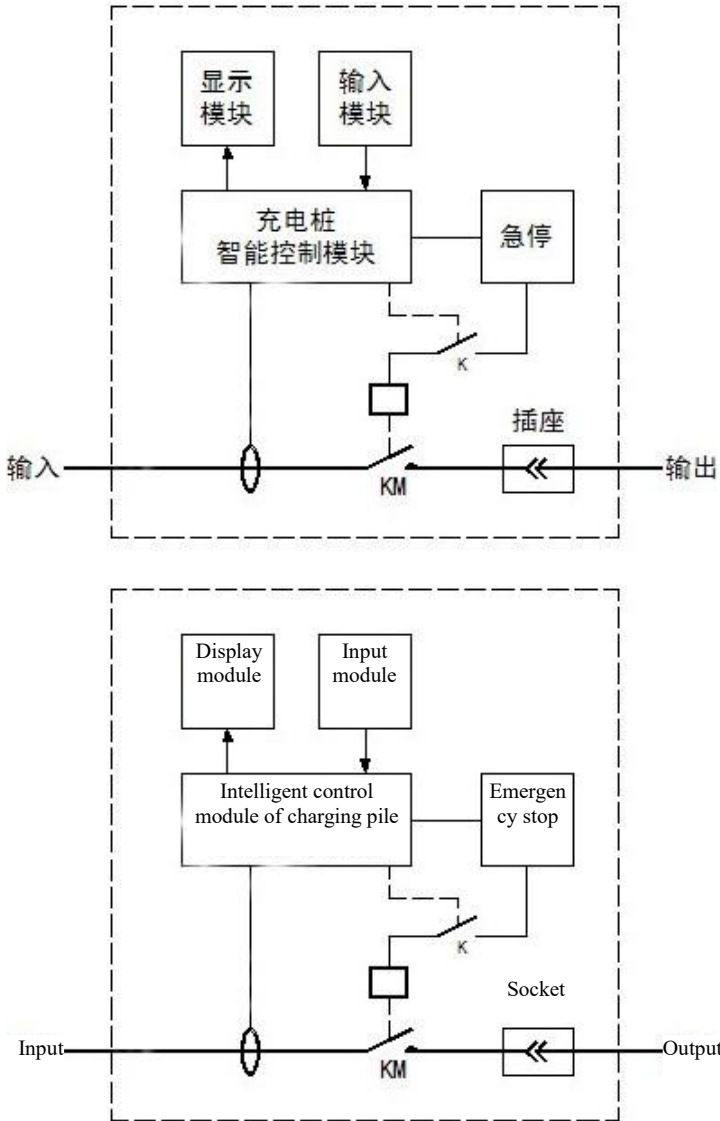
详细规格 Detailed Specification	产品型号 Product Model	FY5860-A-1-32A/220V-D	
外观结构 Appearance structure	产品名称 Product name	单相交流桩 Single-phase AC pile	
	产品类型 Product type	简易家用版 Simple home version	
	外壳材质 Shell material	黑色钢化玻璃面板, PC 材质机身 Black tempered glass panel, PC body	
	设备尺寸 Equipment dimension	310*161*79.8mm (L*W*H)	
	安装方式 Installation method	壁挂式\便携式 Wall-mounted/portable	
	走线方式 Wiring method	下进下出 Getting in and going out from the bottom	
	设备重量 Equipment weight	<6kg	
	枪长度 Gun length	7.65Feet	
	电气指标 Electrical indexes	输入电压 Input voltage	240V
输入频率 Input frequency		50Hz	
最大功率 Max. power		11KW	
输出电压 Output voltage		220V	
输出电流 Output current		48A	

	待机功耗 Standby power consumption	<3W
环境指标 Environmental indexes	适用场景 Applicable scene	户内 / 户外 Indoor / Outdoor
	工作温度 Operating temperature	-30°C ~ +55°C
	工作湿度 Operating humidity	5% ~ 95%无凝露 5% ~ 95%, without condensation
	工作海拔 Height above sea level	<2000m
	防护等级 Protection level	IP65
	冷却方式 Cooling method	自然冷却 Natural cooling
	安规认证 Safety certification	[UL 2594:2016 Ed.2] [CSA C22.2#280:2016 Ed.2]
	MTBF	100,000 小时 100,000 hours
	特殊防护 Special protection	防 UV 设计 UV protection design
安全设计 Safety design	过压保护、欠压保护、过载保护、漏电保护、接地保护、过温保护、低温保护、防雷保护、 Over-voltage protection, under-voltage protection, overload protection, earth leakage protection, grounding protection, over-temperature protection, low-temperature protection, lightning protection	

1.4 产品性能与特点

1.4 Product Performance and Features

产品性能

Product performance

- 模块化设计，稳定可靠：设备采用模块化设计原则，配置灵活，维护方便。

- Modular design, stable and reliable: Modular design principle is adopted for the equipment, with flexible configuration and convenient maintenance.
- 全方位保护，运行安全：具备过压保护、欠压保护、过载保护、漏电保护、接地保护、过温保护、低温保护、防雷保护、倾倒保护，确保设备安全可靠运行，有效防止意外情况发生。
- All-round protection and safe operation: It has over-voltage protection, under-voltage protection, overload protection, earth leakage protection, grounding protection, over-temperature protection, low-temperature protection, lightning protection and toppling protection, ensuring safe and reliable operation of the equipment and effectively preventing accidents.
- 使用方便：安装便捷化、使用更方便。
- Easy to use: Easy to install and use.

产品特点

Product features

- 防护等级高：防护等级 IP65，支持户外恶劣环境，无需额外架设雨棚等。
- High protection level: IP65, supporting outdoor harsh environment, not needing to set up additional canopy, etc.
- 独创倾倒防护设计：当设备通电过程中因意外事故导致倾斜度超过 30°时，立即切除电源、停止输出，保护人身和设备安全。
- Original toppling protection design: When the inclination of the equipment exceeds 30° due to accidents in the electrifying process, the power supply will be turned off immediately and the output shall stop to protect the personal and equipment safety.
- 低功耗：设备待机功耗低至 3W，节能低耗，3 分钟无操作进入睡眠模式。
- Low power consumption: The standby power consumption of the equipment is as low as 3W, energy saving and low consumption.
- 兼容性强：设备为简易家用版，可软件配置为即插即用运行模式，只需软件设置、无需硬件改造。
- Strong compatibility: The equipment is simple home version, and can be configured in plug and play operation mode with software. Only the software needs to be set, while the hardware does not need to be transformed.
- 结构精简：占用空间小，轻便，既可以安装固定，也可便携，
- Simple structure: Occupying a small space, lightweight, the equipment can be fixed or portable,

1.5 产品使用环境

1.5 Operating Environment of Product

- 海拔≤2000 米

- Height above sea level: ≤2000m
- 设备运行环境温度-30°C~55°C
- Operating ambient temperature of equipment: -30°C~55°C
- 空气相对湿度 5%~95%
- Relative air humidity: 5%~95%
- 户内/户外运行
- Indoor/Outdoor operation
- 桩体周围远离易燃易爆物品
- The pile surroundings shall keep away from flammables and explosives

1.6 产品设计规范

1.6 Design Specifications of Products

单相交流充电桩根据最新国标设计，在功能和性能上符合行业标准。所用技术标准见下表。

The single-phase AC charging pile is designed according to the latest national standard and meets the industry standard in function and performance. The technical standards used are shown in the table below.

表 2：技术标准及规定

Table 2: Technical Standards and Regulations

序号 No.	标准号 Standard No.	标准名称 Standard Name
1	GB/T 18487.1-2015	电动汽车传导充电系统 第 1 部分：通用要求 Electric Vehicle Conductive Charging System Part 1: General Requirements
2	GB/T 20234.2-2015	电动汽车传导充电用连接装置 第 1 部分：通用要求 Connection Set for Conductive Charging of Electric Vehicles Part 1: General Requirements
3	GB/T 20234.2-2015	电动汽车传导充电用连接装置 第 2 部分：交流充电接口 Connection Set for Conductive Charging of Electric Vehicles Part 2: AC Charging Coupler
4	GB/T 27930-2015	电动汽车非车载传导式充电机与电池管理系统之间的通信协议 Communication Protocols between Off-board Conductive Charger and Battery Management System for Electric Vehicle
5	GB/T 19596-2004	电动汽车术语 Terminology of Electric Vehicles

6	GB/T 17618	信息技术设备抗扰度限值和测量方法 Information Technology Equipment – Immunity Characteristics – Limits and Methods of Measurement
7	GB 9254-2008	信息技术设备的无线电骚扰限值和测量方法 Information Technology Equipment – Radio Disturbance Characteristics – Limits and Methods of Measurement
8	GB 4208-2008	外壳防护等级（IP 代码） Degrees of Protection Provided by Enclosure (IP Code)
9	DL/T 645-2007	多功能电能表通信协议 Multi-function Watt-hour Meter Communication Protocol
10	GB9286-1998	色漆和清漆 漆膜的划格试验 Paints and Varnishes – Cross Cut Test for Films
11	GB 6587.4-1986	电子测量仪器振动试验 Vibration Tests for Electronic Measuring Instruments
12	GB 6587.5-1986	电子测量仪器冲击试验 Shock Tests for Electronic Measuring Instruments
13	GB/T 13384-2008	机电产品包装通用技术条件 General Specifications for Packing of Mechanical and Electrical Product
14	GB/T 17626.2-2006	电磁兼容 试验和测量技术 静电放电抗扰度试验 Electromagnetic Compatibility – Testing and Measurement Techniques – Electrostatic Discharge Immunity Test
15	GB/T 17626.3-2006	电磁兼容 试验和测量技术 射频电磁场辐射抗扰度试验 Electromagnetic Compatibility – Testing and Measurement Techniques – Radiated, Radio-frequency, Electromagnetic Field Immunity Test
16	GB/T 17626.4-2008	电磁兼容 试验和测量技术 电快速瞬变脉冲群抗扰度试验 Electromagnetic Compatibility – Testing and Measurement Techniques – Electrical Fast Transient/Burst Immunity Test
17	GB/T 17626.5-2008	电磁兼容 试验和测量技术 浪涌（冲击）抗扰度试验 Electromagnetic Compatibility – Testing and Measurement Techniques – Surge (Impact) Immunity Test
18	GB/T 17626.6-2008	电磁兼容 试验和测量技术 射频场感应的传导骚扰抗扰度 Electromagnetic Compatibility – Testing and Measurement Techniques – Immunity to Conducted Disturbances, Induced by Radio-frequency Fields

1.7 产品结构

1.7 Product Structure

1.7.1 整体外形图

1.7.1 Outside View

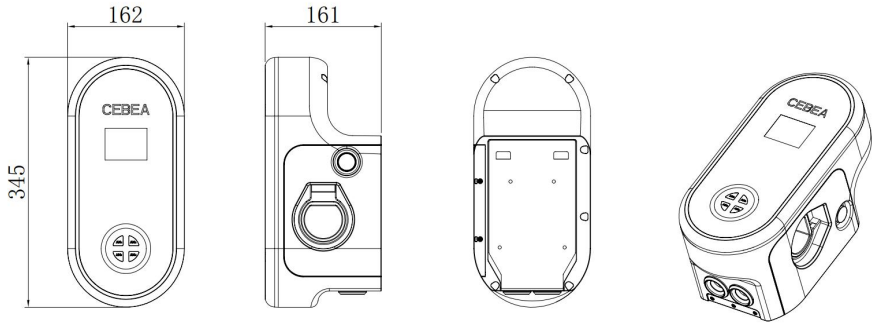

7.2 内部结构图

7.2 Internal Structure Diagram

第 2 章 安装操作说明

Chapter 2 Instructions for Installation and Operation

2.1 开箱检查

2.1 Open-box Inspection

交流充电桩到货后，打开包装，检查以下项目：

After the AC charging pile arrives, open the package and check the following items:

- 目检外观，检查交流充电桩是否在运输中有碰撞损坏，如有损坏，请立即通知承运商。
- Visually inspect the appearance and check whether the AC charging pile is damaged in transit. If there is any damage, please inform the carrier immediately.
- 对照发货装箱清单，检查随机附件型号是否齐全、正确。如发现附件缺少或型号不符，应及时做好现场记录，并立即与公司当地办事处联系。





- Check whether the accompanying accessories are complete and correct according to the packing list.
If the accessories are missing or the model is not consistent, keep the on-site records in time, and inform the local office of the Company immediately.





2.2 安装准备

2.2Preparation for Installation

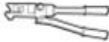

安装工具

Installation Tools

工具名称	图片	主要作用
绝缘力矩扳手		紧固螺栓
两用扳手		紧固螺栓
液压钳		压制OT端子
斜口钳		剪断线缆

Tool Name	Picture	Main Function
Insulation torque spanner		Fastening the bolts
Combination spanner		Fastening the bolts Emergency stop
Hydraulic tongs		Press terminals
Diagonal pliers		Cutting off the cables

工具名称	图片	主要作用
万用表		检查电气连接及电气参数
十字螺丝刀 (PH2×150mm、 PH3×250mm)		紧固螺丝
绝缘活动扳手		紧固螺栓

Tool Name	Picture	Main Function
Multi-meter		Checking electrical connection and electrical parameters
Cross screwdriver (PH2×150mm, PH3×250mm)		Fastening the screws
Insulation adjustable spanner		Fastening the bolts

线缆准备

Preparation of Cables

充电桩供电推荐线缆规格如下：

The following cable specifications for charging pile power supply are recommended:

线缆名称 Cable Name	线缆规格 Cable Specification	长度 Length	备用 Reserve
电力电源线 Power line	3*8AWG 及以上单相电源电缆 Single-phase power cable of 3*8mm ³ and above	以具体施工长度为准 Subject to the specific construction length	
断路器 Circuit breaker	单相断路器 63A (单相 48A 充电桩) Single-phase 63A circuit breaker (Single-phase 48A charging pile)		

2.3 安装流程

2.3 Installation Process

- 1) 布线、安装壁挂支架
- 1) Wiring, installation of wall-mounted bracket

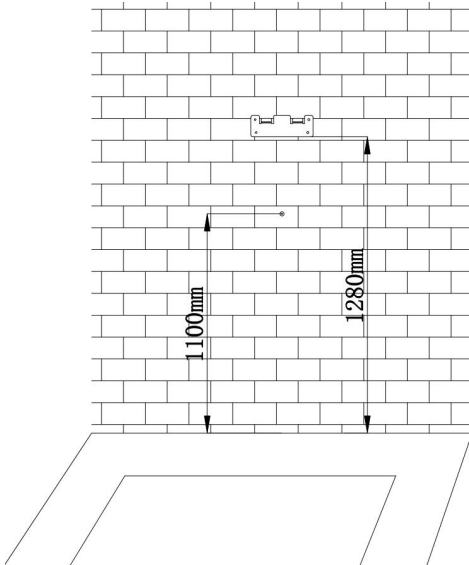

2) 充电桩进线安装

2) Incoming installation of charging pile

3) 壁挂式安装及固定

4) Wall mounting and fixing

将设备背后安装孔从正面方挂入墙上固定螺钉上，并固定；

Hang the mounting hole at the back of the equipment onto the fixed screw on the wall from the front and fix it;

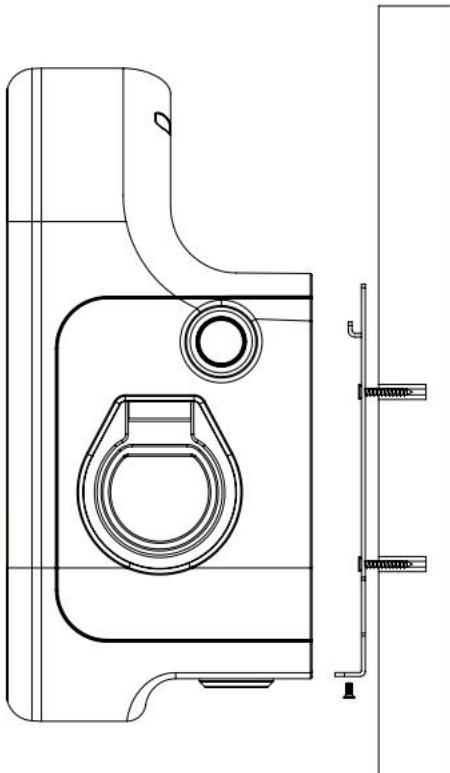

5) 枪座安装

6) Installation of gun base

在设备的正下方，安装枪座，安装高度，距离地面 800mm

Install the gun base under the equipment, with an installation height of 800mm from the ground

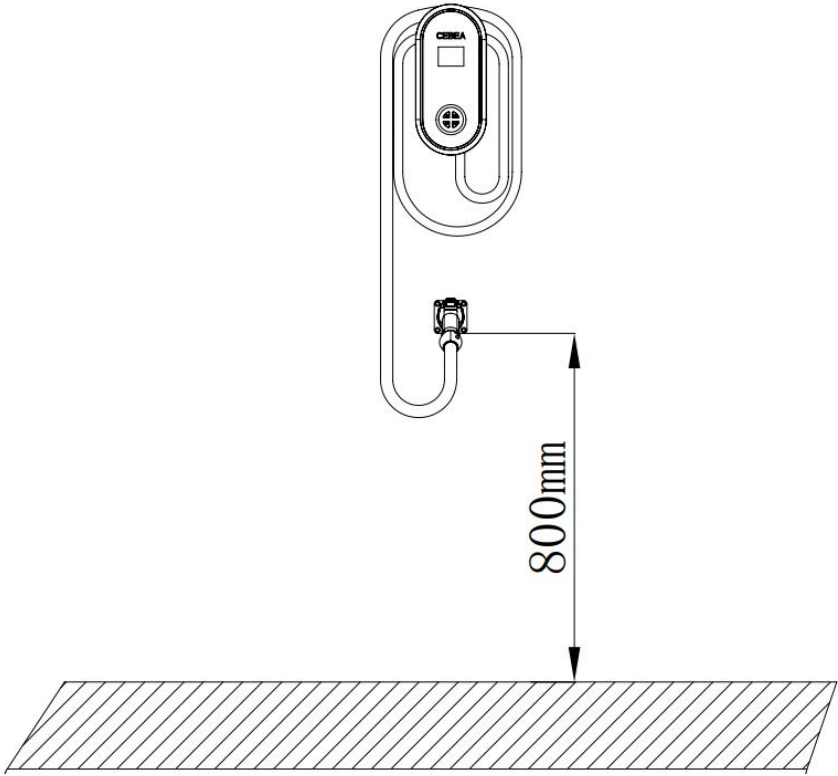

5) 安装结束，效果如下图：

5) The installation is over, and the effect is as shown in the figure below:

2.4 设备上电检查、调试

2.4 Power-on Inspection and Debugging of Equipment

1) 运行前检查

1) Pre-operation inspection

运行前，请仔细检查并确保下列项：

Please carefully check and ensure the following items before operation:

- 交流桩安装位置便于操作和维修
- The installation position of AC pile is convenient for operation and maintenance
- 交流桩与附件正确连接并安装牢固

- The AC pile and accessories are correctly connected and firmly installed
- 交流进线端漏电保护开关选型合理
- The type selection of earth leakage circuit breaker at AC incoming terminal is reasonable
- 没有外部物体或零件遗留在交流桩顶上
- There are no external objects or parts left on the top of AC pile

2) 设备上电

2) Equipment power-on

1. 确定以上运行前检查项目均满足要求

1. Confirm that all the above items meet the requirements before operation

2. 闭合电源进线漏电保护断路器

2. Close the earth leakage circuit breaker of incoming power line

3. 交流桩上电：约有 5 秒的开机自检时间，**开机过程指示灯绿灯保持常亮。**

3. Power-on of AC pile: There is about 5 seconds of power-on self-test time, and the indicator lamp will be on in red, yellow and green alternately, 1 second respectively

4. 上电自检完成后，观察 LED 指示灯状态。

4. After power-on self-test, observe the status of LED indicator lamp.

- **正常待机：绿灯常亮。**

- Normal standby: The green light is breathing, on for 1S, and off for 3S

- **设备故障：黄灯按照错误报闪**

- **Equipment fault: The red lamp is always on**

3) 显示界面

中文——Chinese

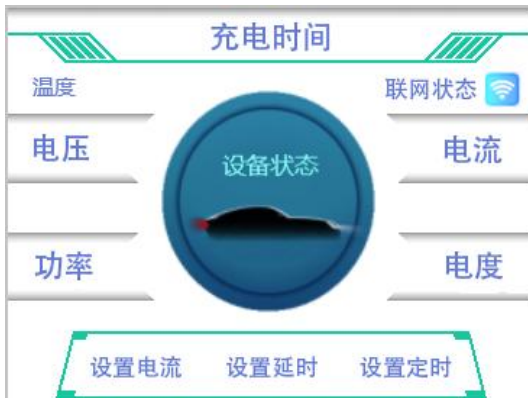

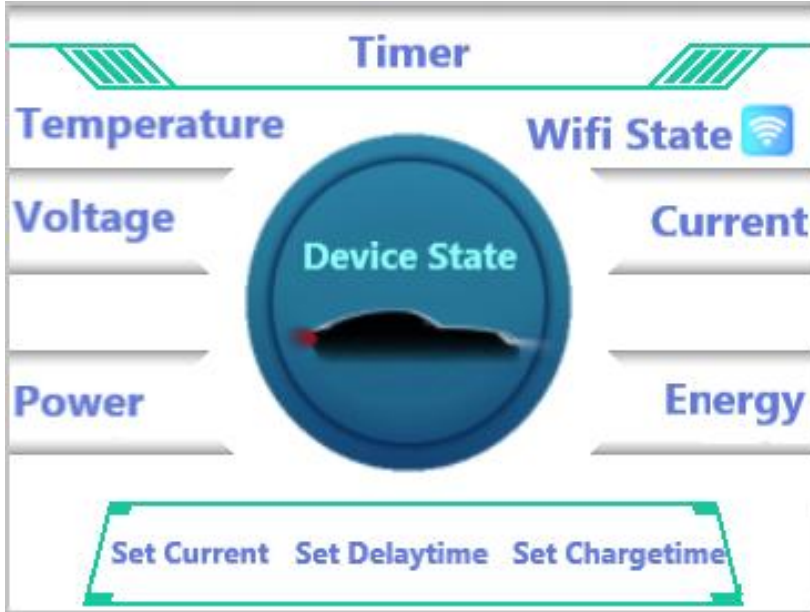

2.5 充电操作

2.5 Charging Operation

1) 充电连接

1) Charging connection

电动车主将电动车入栈停好后，从桩上拿下充电枪并插入电动汽车的充电座，请要仔细检查是否插到位，确保连接可靠。

After the electric vehicle owner stops the electric vehicle in place, take down the charging gun from the pile and insert it into the charging base of the electric vehicle. Please carefully check whether it is inserted in place to ensure reliable connection.

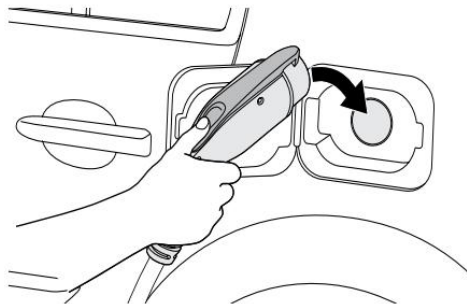

2) 充电控制

2) Charging control

对于该款标准版充电桩，除了要保证充电枪可靠插入电动车外，还需要接受到上位的充电指令，才可向电动汽车充电。上位的充电指令可能来自 CPU 或 M1 非接触式卡，

For this standard charging pile, ensure that the charging gun is reliably inserted into the electric vehicle, and it receives the upper charging instruction before charging the electric vehicle. The upper charging instruction may come from CPU or M1 contactless card,

刷卡进行充电

Charging by swiping the card

充电用户用户进行充电，需到设备管理者处办理充电卡，进行充电操作；

Charging users need to apply for the charging card to the device manager to charge their vehicles;

车主将车停好后，连接好充电枪，使用充电卡，在设备面板的刷卡区域，卡与刷卡区域的距离不低于 2MM，停留 3S 左右，即可向电动汽车充电，

After parking the vehicle, connect to the charging gun and swipe the charging card in the card swiping area on the equipment panel, and keep a distance of not less than 2MM between the card and the card swiping area. Stay for about 3S, and then you can charge your electric vehicle;

3) 充电停止

3) Charging stops

当充电桩工作状态时，车主需要结束充电，可以通过以下方式：

When the charging pile is in working state, the vehicle owner can end charging in the following ways:

1. 刷卡结束充电，待车辆解锁，拔枪；

1. Swipe the card to end charging, and when the vehicle is unlocked, draw the gun;

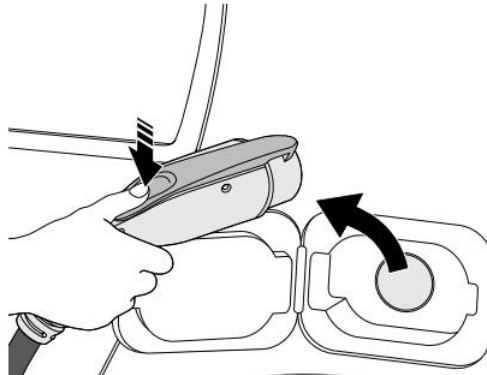

2.6 充电远程控制 (2.6 为新加内容, 需要翻译)

1) 应用下载

Download the Doodle Smart App in the App store



Tuya Smart

2) Configure the charging device network

Make sure that the charging device and the mobile phone are in the same Wifi network (5G band Wifi is not currently supported) and I am near the charging device. When the device is powered on, open the Doodle smart APP, and the networking status of the charging device will be displayed as follows:



Wait for the network distribution operation



Internet access



Not connected to the Internet

下面是配网操作流程示范:

1. 打开涂鸦智能 App, 轻触右上角角度的加号, 自动发现设备, 打开权限, 开始搜索, 如下:

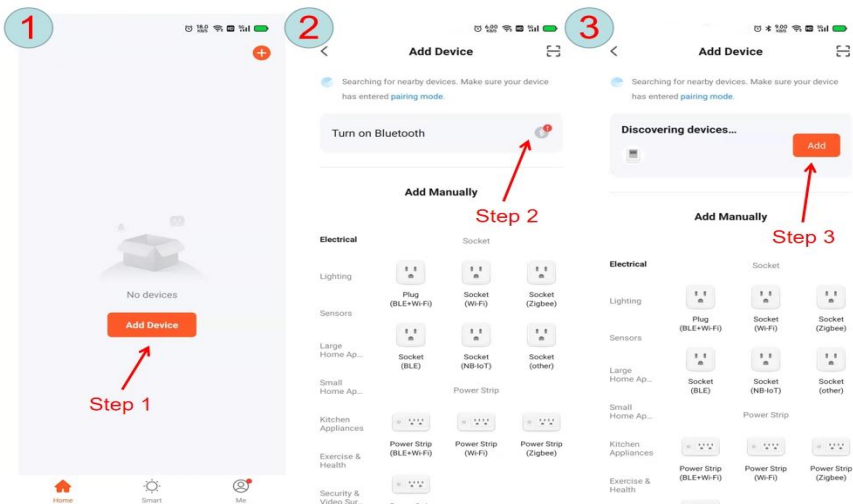

2. Enter the working Wifi and password of the device, wait for the charging device to be connected successfully, and enter the charging display interface of the App

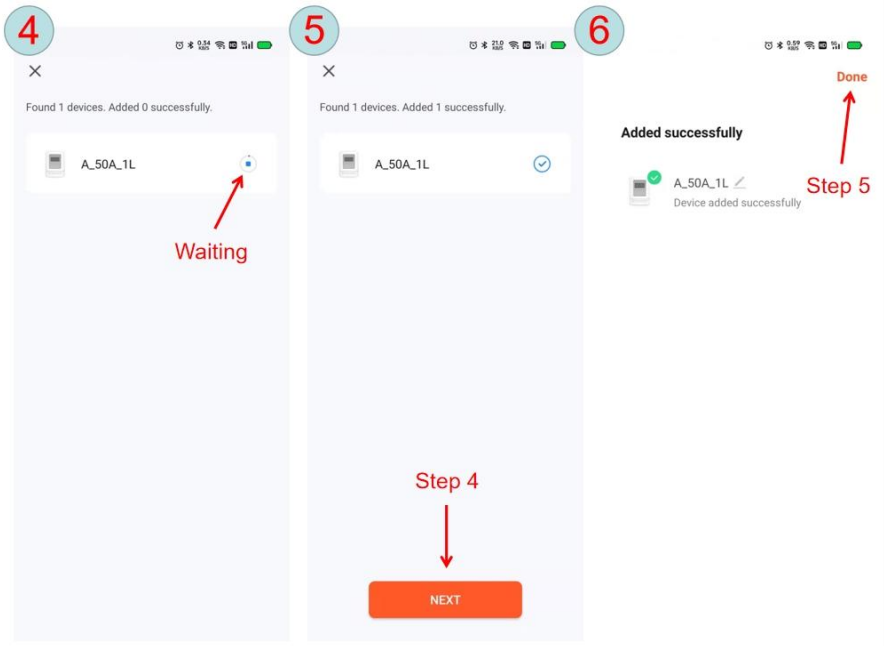

3. If there is a timeout during the distribution process, or the distribution fails, please check whether the Wifi network has been connected to the network and the router is working in the 2.4G band or the mobile phone device is too far away from the charging device, resulting in the Bluetooth connection failure. If the above situation, repeat the above operations to successfully distribute the network. If the problem still cannot be solved, please contact customer service for processing.

3) APP 充电界面操作



Before you start charging, make sure the charging gun is plugged into the vehicle. In the upper right corner icon of the charging display interface, there are device information, offline reminder, sharing device and other functions, users can use it by themselves. Note: The Remove Device button at the bottom of the list requires rewiring, which can be done when changing the home Wifi password or changing the user of the device.

第 3 章 常见故障处理

Chapter 3 Common Troubleshooting

故障名称 Fault Name	故障现象可能原因 Possible Causes of Faults	排障建议 Suggestions
AC 过压 AC over-voltage	交流输入电压过高 AC input voltage is too high	1. 请电工测试空开输入电压 1. Ask an electrician to test the input voltage of air switch
		2. 如果实际电压短时超过 264Vac, 则等待电网自行恢复至正常电压范围内。 2. If the actual voltage is greater than 264Vac for a short time, wait for the peer-to-peer network to recover to the normal voltage range.
		3. 如果实际电压长期大于 264Vac, 请联系供电部门 3. If the actual voltage is greater than 264Vac for a long time, please contact the power supply department
		4. 如果实际电压小于 264Vac, 请联系我们; 4. If the actual voltage is less than 264Vac, please contact us;
AC 欠压 AC under-voltage	交流输入电压过低 AC input voltage is too low	1. 请电工测试空开输入电压 1. Ask an electrician to test the input voltage of air switch
		2. 如果电压短时低于 85Vac, 则等待电网自行恢复至正常电压范围内。 2. If the voltage is lower than 85Vac for a short time, wait for the peer-to-peer network to recover to the normal voltage range.
		3. 如果实际电压长期小于 85Vac, 请联系供电部门 3. If the actual voltage is less than 85Vac for a long time, please contact the power supply department
		4. 如果实际电压大于 85Vac, 请联系我们; 4. If the actual voltage is greater than 85Vac, please contact us;
AC 过流 AC over-current	交流输入电流过大 AC input current is too high	1.立即断开配电箱漏电/过流保护开关 1. Immediately turn off the leakage/over-current protection switch of the distribution box

		<p>2.检查交流桩输出线两线之间是否有低阻抗连接</p> <p>2. Check whether there is a low-impedance connection between two output lines of AC pile</p> <p>3.排除以上问题后,重新上电,如果故障依然存在,请联系我们</p> <p>3. After the above problems are eliminated, power on again. If the fault still exists, please contact us</p>
过温 Over-temperature	<p>内温度大于 85 度</p> <p>The interior temperature is greater than 85°C</p>	<p>1.检查交流桩安装环境,核查旁边是否有发热设备或器件,确保环境温度需在 60°以下</p> <p>1. Check the installation environment of AC pile to see whether there is heating equipment or devices nearby, and ensure that the ambient temperature is below 60°C</p> <p>2.如果故障不能排除,请联系我们</p> <p>2. If the fault can't be eliminated, please contact us</p>
漏电流超标 Leakage current exceeds the limit	<p>漏电流大于 20mA</p> <p>The leakage current is greater than 20mA</p>	<p>1.立即断开配电箱漏电/过流保护开关</p> <p>1. Immediately disconnect the leakage/over-current protection switch of the distribution box</p> <p>2.检查交流桩输出线是否有破损或对地有低阻抗连接</p> <p>2. Check whether the output line of AC pile is damaged or has low-impedance connection to the ground</p> <p>3.排除以上问题后,重新上电,如果故障依然存在,请联系我们</p> <p>3. After the above problems are eliminated, reset the reset switch of leakage current protector, and power on again. If the fault still exists, please contact us</p>
漏电流传感器异常 Leakage current sensor is abnormal	<p>检测漏电流的传感器出现异常</p> <p>The sensor for detecting the leakage current is abnormal</p>	<p>1.立即断开配电箱漏电/过流保护开关</p> <p>1. Immediately disconnect the leakage/over-current protection switch of the distribution box</p> <p>2.检查交流桩输出线是否有破损或对地有低阻抗连接</p> <p>2. Check whether the output line of AC pile is damaged or has low-impedance connection to the ground</p> <p>3.排除以上问题后,重新上电,如果故障依然存在,请联系我们</p> <p>3. After the above problems are eliminated, power on again. If the fault still exists, please contact us</p>

接地故障 Ground fault	输入/输出接地不良 或输入 L/N 反接 The input/output grounding is poor or the input L/N connection is reverse	1.立即断开配电箱漏电/过流保护开关 1. Immediately disconnect the leakage/over-current protection switch of the distribution box
		2.检查交流桩输入/输出线接地是否正常，输入 L/N 是否按正常顺序连接 2. Check whether the grounding of AC pile input/output line is normal and whether the input L/N is connected according to normal sequence
		3.排除以上问题后，重新上电，如果故障依然存在，请联系我们 3. After the above problems are eliminated, power on again. If the fault still exists, please contact us
充电枪连接异常 Connection of charging gun is abnormal	充电枪 CC/CP 连接异常 CC/CP connection of charging gun is abnormal	1.检查充电枪的连接是否正确可靠 1. Check whether the connection of charging gun is correct and reliable
		2.如果故障依然存在，请联系我们 2. If the fault still exists, please contact us

FCC Statement

This device complies with part 15 of the FCC Rules. Operation is subject to the following two conditions:

(1)This device may not cause harmful interference, and (2)this device must accept any interference received, including interference that may cause undesired operation.

This equipment has been tested and found to comply with the limits for a Class B digital device, pursuant to part 15 of the FCC Rules.

These limits are designed to provide reasonable protection against harmful interference in a residential installation.

This equipment generates, uses and can radiate radio frequency energy and, if not installed and used in accordance with the instructions, may cause harmful interference to radio communications.

However, there is no guarantee that interference will not occur in a particular installation.

If this equipment does cause harmful interference to radio or television reception, which can be determined by turning the equipment off and on, the user is encouraged to try to correct the interference by one or more of the following measures:

- .Reorient or relocate the receiving antenna.
- .Increase the separation between the equipment and receiver.
- .Connect the equipment into an outlet on a circuit different from that to which the receiver is connected.

.Consult the dealer or an experienced radio/TV technician for help.

Caution: Any changes or modifications to this device not explicitly approved by manufacturer could void your authority to operate this equipment.

RF Exposure Information

This equipment complies with FCC radiation exposure limits set forth for an uncontrolled environment. This equipment should be installed and operated with minimum distance 20cm between the radiator and your body.