

三盛创电子

Shenzhen Sanshengchuang Electronic Technology Co., Ltd.

承 認 書

客 戶:
CUSTOMER: **Dongguan Chuangjie Electronics Co., Ltd.**

客 戶 料 號:
CUST P/N:

三 盛 料 號:
FINE P/N: **磁吸线圈 6.5uH/0.08*72P*10TS**

產 品 型 號:
DESC: **Φ43.5MMX5.3MMX0.8MM 开槽**

日 期:
DATE: **2022.11.30**

版 本:
Version: **A.0**

擬制 PREPARED BY	審核 CHECKED BY	批准 APPROVED BY	客戶承認 CUSTOMER APPROVE
林素玲	安帅印	安帅印	

SPECIFICATION

產品型號: DESC	Φ20.5x41-6.5uH-0.08x72P-	版本 Rev: A.0	客戶 CUST: 客戶料号 CUST P/N:	XXX
---------------	--------------------------	----------------	----------------------------	------------

一、尺寸 DIMENSION:(mm)

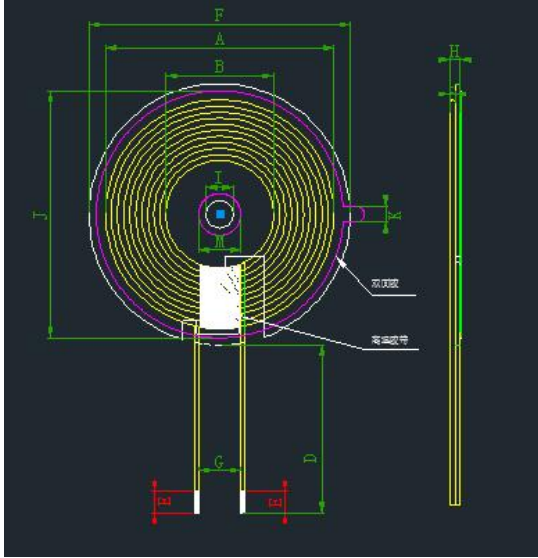

A	41.0±1.0
B	20.5±0.5
C	1.25 Max
D	10±2
E	3±1
F	43.5±0.5
G	10.0 ref
H	2.0 Max
I	5.3 ref
M	8.0 ref
J	42±1
K	3.0±1

二、原理图 SCHEMATIC DIAGRAM:

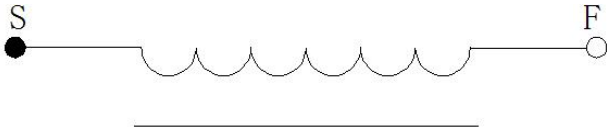

Note:

- 1.交叉出线;
Cross outlet
- 2.出线位置缠8mm(ref)宽度高温胶纸 1-2Ts;
Wrap 8mm(ref) wide high-temperature adhesive tape for 1-2Ts at the outlet position.
- 3.线圈贴圆形硬磁片带槽,磁片尺寸 43.5±0.5mm,内孔 5.3±0.5mm,厚度为 0.8±0.1mm.
The coil is attached with a circular hard magnetic sheet with a slot, the size of the magnetic sheet is 43.5±0.5mm, the inner hole is 5.3±0.5mm, and the thickness is 0.8±0.1 mm.
- 4.线圈背面贴双面胶
Stick double-sided tape on the back of the coil.

三、绕线参数 Winding Specification:

序号 NO.	端子 TERMINAL		线径 WIRE	圈数 Turns	绕线方向 Winding Direction
1	S	F	热风线 0.08*72P	10Ts	CCW

四、电气特性 ELECTRICAL CHARACTERISTICS:

温度 TEMPERATURE:25±10°C, 湿度 RELATIVE HUMIDITY:65±20%

序号 NO.	项目 ITEM	端子 TERMINAL	标准 SPECIFICATION	测试条件 TEST FREQUENCY	测试仪器 TEST EQUIPMENTS
1	IND.	S-F	4.0uH ±10%单独线圈	100KHz/1.0V	LCZ METER 1062B
2	IND.	S-F	6.5uH ±10%加磁片	100KHz/1.0V	LCZ METER 1062B
3	DCR	S-F	≤50m Ω	100KHz/1.0V	LCZ METER 502B
4	Q	S-F	≥75	100KHz/1.0V	LCZ METER 502B

拟制/日期 PREPARED BY/DATE	审核/日期 CHECKED BY/DATE
林素玲 2022.11.30	安帅印 2022.11.30