



Spectra Precision Atmel RF Module Operation Description

Content

Hardware.....	1
Technical Data of the Atmel AT86RF233 Transceiver	1
Atmel RF Module Connection Description	2
SPI Interface	2
RF Operation.....	3
IEEE802.15.4 Frame Format	3
RF Configuration Options	4
RF Operations Modes	4
Active Operation Modes	4

Hardware

The RF module works with the Atmel RF transceiver AT86RF233 and the 2.4GHz Front End SE2431L-R from Skyworks. The range on the module PCB that contains the RF transceiver and the connected antenna network is covered with a metal shield. The antenna is a chip Antenna.

Technical Data only for the Atmel AT86RF233 Transceiver itself , not valid for the complete module.

The AT86RF233 is the transceiver of the Atmel RF module. The following list contains the technical data of the Atmel AT86RF233 in combination with the Front End.

- Operating frequency range 2405MHz to 2480MHz
- O-QPSK modulation
- Channel Bandwidth 3.2MHz
- Max output power 24dBm
- Operating temperature range -20°C to +50°C
- Operating voltage range 2V to 3.8V
- 250kbps data rate
- 4 wire SPI
- IEEE802.15.4 compliant DSSS baseband



Atmel RF AMP Module Connection Description

In the following table the connector pins of the Atmel RF module are listed and described.

Name	Description
VDD	Power supply (1.8 ... 3.8V) pin
MISO	Master system SPI reception / module/transceiver SPI transmission pin
SCLK	SPI clock (generated by the master system, max. 5MHz)
RESET_n	System reset (inverted)
IRQ	Interrupt request signal output
SLP_TR	Controls sleep, deep sleep, transmit start
CPS	Front End module select for RF_TX_RX
nSEL	Module/transceiver chip select pin (inverted)
MOSI	Master system SPI transmission / module/transceiver SPI reception pin
GND	Ground pin

SPI Interface

The communication with the Atmel RF module transceiver is realized with a 4-wire SPI (CS_N, CLK, SPI_IN, SPI_OUT). The following picture illustrates the SPI timing requirements.

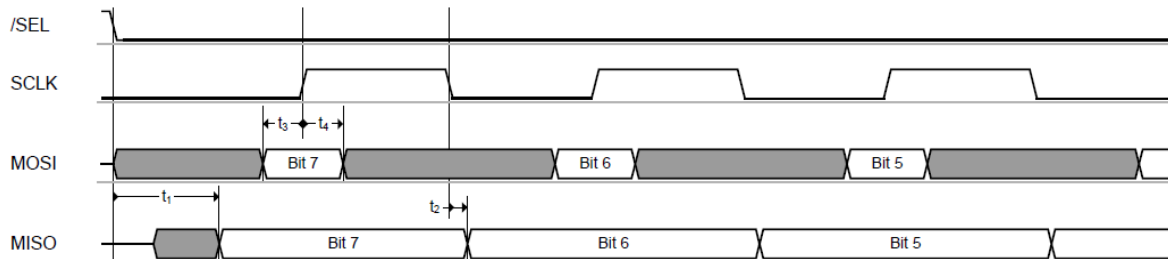

The following table describes the parameter of the picture above.

Parameter	Description	Min	Typ	Max	Unit
t1	/SEL falling edge to MISO active			180	ns
t2	SCLK falling edge to MISO out	25			ns
t3	MOSI setup time	10			ns
t4	MOSI hold time	10			ns



RF Operation

This section describes the possible RF operations of the AT86RF233 and therewith the Atmel RF module.

This device complies with part 15 of the FCC Rules. Operation is subject to the following two conditions:

- (1) This device may not cause harmful interference, and
- (2) this device must accept any interference received, including interference that may cause undesired operation.

Changes or modifications not expressly approved by the party responsible for compliance voids the user's authority to operate this equipment.

Specs:

- Operating frequency range 2400MHz to 24835MHz
- O-QPSK modulation
- Channel Bandwith 3.2MHz
- Rated peak power: 4.5 dBm EIRP
- Operating temperature range -20°C to +50°C
- Operating voltage range 2.8V to 3.6V DC
- 250kbps data rate
- 4 wire SPI
- IEEE802.15.4 compliant DSSS baseband

IEEE802.15.4 Frame Format

The communication bases on the physical layer of IEEE802.15.4 standard, but the AT86RF233 can be configured for handling the MAC layer of the IEEE802.15.4 standard.

The following picture illustrates the IEEE802.15.4 frame format which is supported by the AT86RF233 transceiver.

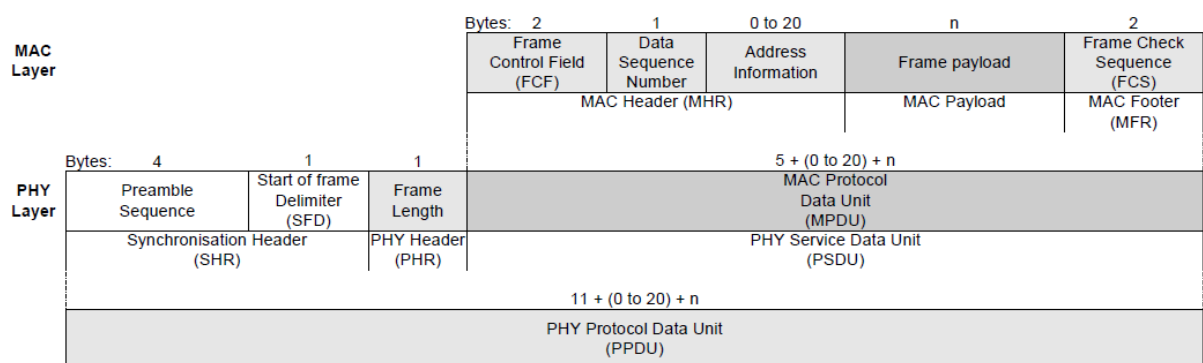



RF Configuration Options

The following list contains possible configurations which can be set by SPI commands at the AT86RF233 transceiver on the Atmel RF module.

- Rated peak power: 4.5 dBm EIRP
- Output power can only be set by the firmware with SPI commands; so the end-user is not able to change the output power
- RF Channel Selection (2400 ... 24835MHz)
Following the IEEE802.15.4 standard following channels can be selected:
2400 ... 24835MHz in 5Mhz steps
(k=1: 2405MHz, k=2: 2410MHz, k=3: 2415Mhz, ... , k=15: 2475MHz, k=16: 2480MHz)
- A clear channel assessment is supported that allows a simple listen before talk implementation

RF Operations Modes

The RF module supports different operation modes. Overall different power modes are supported which limits the module in possible operations, but allows improvement of power consumption.

The following picture illustrates the different power modes, the transitions between the power modes and the power consumption of the modes.

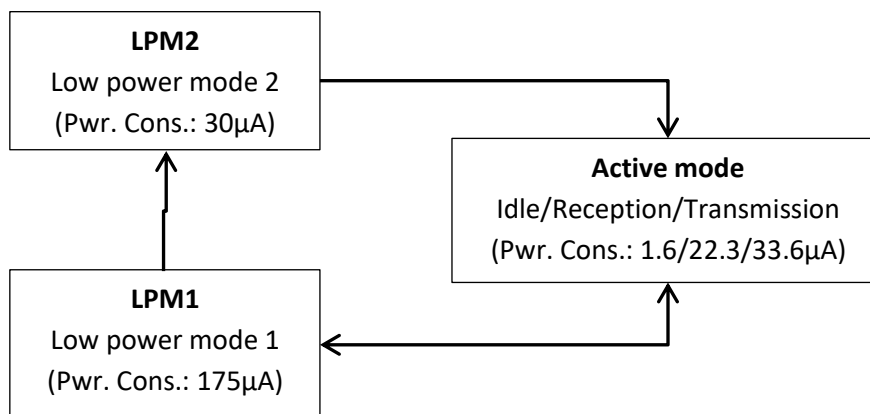

Active Operation Modes

In the active mode the RF module transceiver can be only in one of the following states.

- **Idle**
- **TX:** Transmission (The next frame in transmission queue is sent out, then Idle or Reception mode (dependent on AT86RF233 configuration). This state is kept only so long, as AT86RF233 is transmitting a frame
- **RX:** Reception

The states can be changed with SPI commands. The simplified state table with transition times illustrates the possible operation mode changes.



State	Command	Condition	Next State	Transition Time
Idle		rxenable != 0	RX	192μs
RX		rxenable == 0	Idle	
RX	STXON		TX	192μs
RX	SROFF	txactive == 0	Idle	
TX		frame sent && rxenable != 0	RX	190μs
TX		frame sent && rxenable == 0	Idle	
TX	SROFF	txactive == 0	Idle	