

# MIDI Septier Cellular Platform

## Compact Mobile Base Station Systems

The Septier MIDI Platform is a two Carrier Mobile Base Station solution give ability to work on 2G to 4G cellular Network.

The MIDI platform is based on Intel i7 support embedded Linux operating system and provide base station solution and GNSS functionalities to meet application demands.

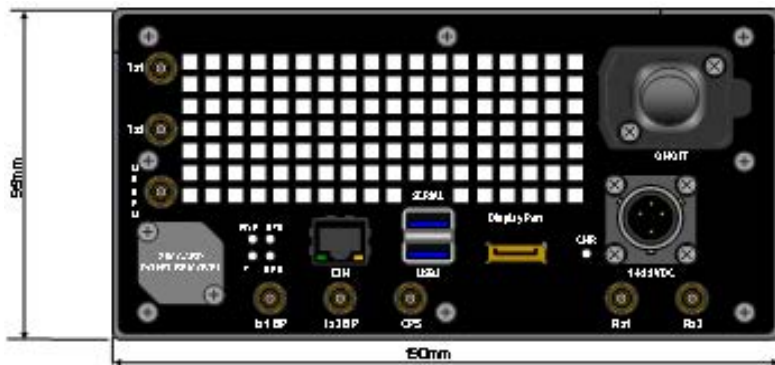
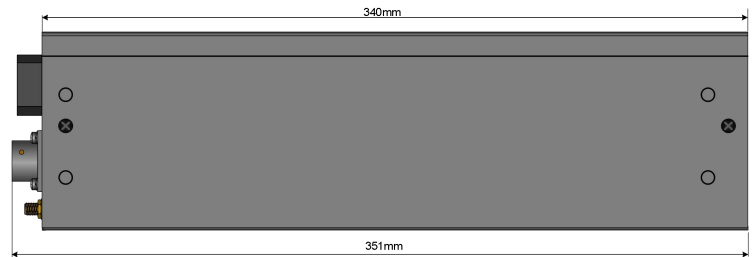
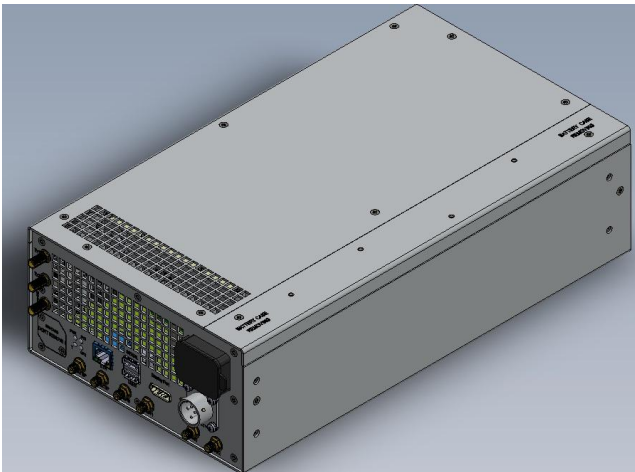

# Application

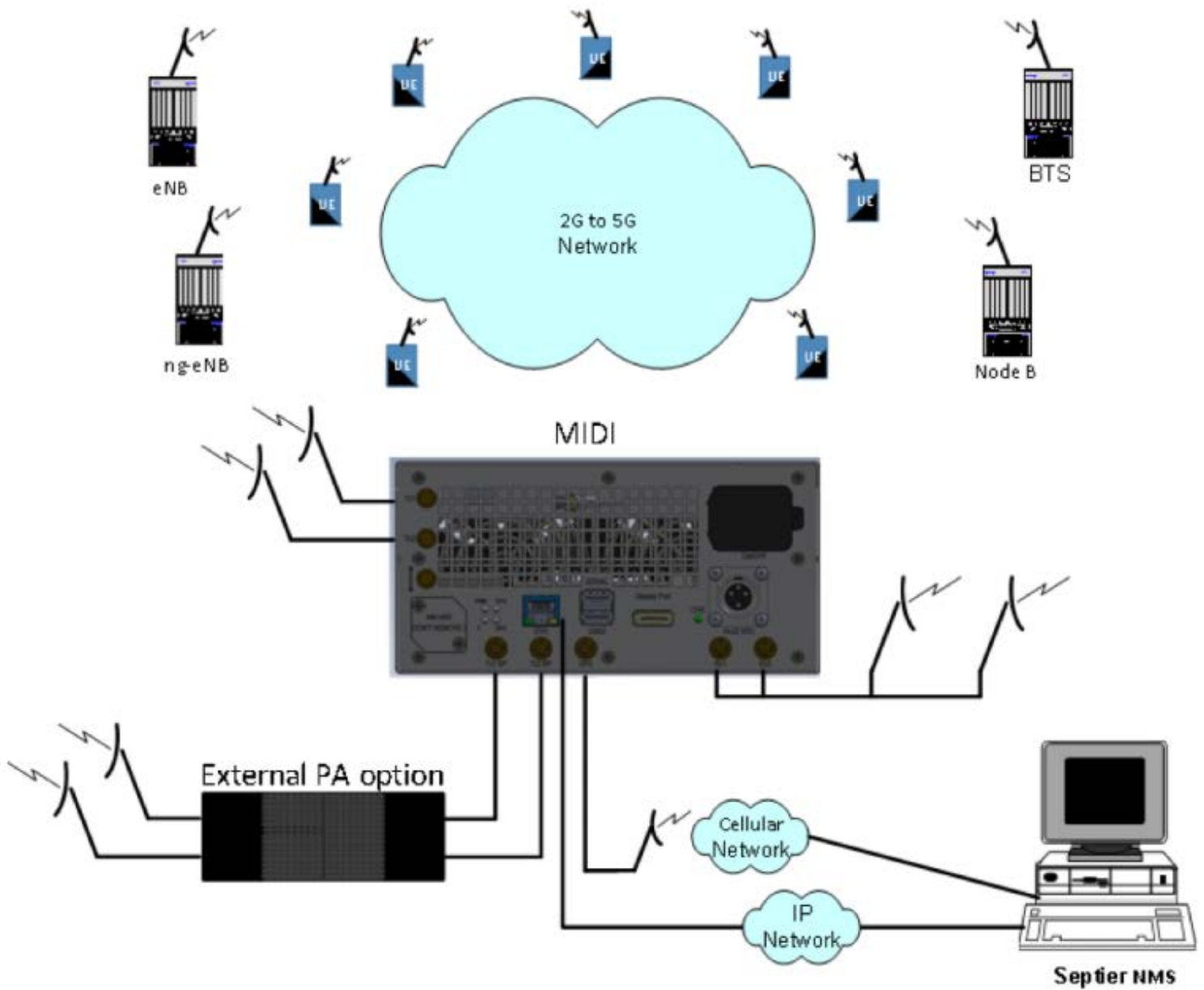

## Highlights

---

The MIDI platform features up to 2xSDR carrier, providing extremely high performance cellular applications. The unique thermal solution supports efficient front-to-back cooling solution

- Small size or 19-inch rack-mount enclosure
- Efficient front-to-back cooling
- Up to 2 independent SDR ( software defined Radio)
- Includes Internal charger and Li-Ion battery
- Includes Internal dual RF Power Amplifier, up to 5Watt output per port (Lte signal)
- Support External RF Power Amplifier (bypass option)
- Support Ethernet or Lte network for Remote control
- Network management using Septier GUI software
- Support GNSS (GPS, GLONASS, Galileo, QZSS)
- Support GSM 850/1900
- Support WCDMA B2/B4/B5
- Support LTE-FDD Bands: B25/B26/B66
- Dimension: 340x190x95mm (L\*W\*H)

## System Interfaces

The platform provides the following interfaces and peripheral connectivity

- UIM interface
- Internal 3S Li-Ion battery (130Wh)
- RF separated TX/RX interface. Additionally internal Power Amplifier bypass output option
- On/Off power control
- USB3.0 Interface
- UART serial port over USB2.0 Interface
- GNSS external RF Antenna
- Remote control modem external RF Antenna
- Ethernet 1000/100/10 Interface
- Display port Interface
- External power supply
- System status LEDs

## Power Supply Specification

- 360W continues power supply
- AC input: 85 to 264V, 47 to 63Hz
- Output: 15Vdc
- Protections : Short circuit/Overload/Over voltage/Over temperature
- Fully Enclosed plastic case
- Built-in active PFC function
- Fanless designed with -30 to +70C working temperature
- Dimension: 220x95x46mm (L\*W\*H)

## Environmental specifications

- Temperature operating -5C to +50C
- Non-operating temperature -25C to 80C
- Humidity Operating 20% to 80% non-condensing

# FCC Warning

This device complies with part 15 of the FCC Rules. Operation is subject to the following two conditions: (1) This device may not cause harmful interference, and (2) this device must accept any interference received, including interference that may cause undesired operation.

Any Changes or modifications not expressly approved by the party responsible for compliance could void the user's authority to operate the equipment.

**Note:** This equipment has been tested and found to comply with the limits for a Class B digital device, pursuant to part 15 of the FCC Rules. These limits are designed to provide reasonable protection against harmful interference in a residential installation. This equipment generates uses and can radiate radio frequency energy and, if not installed and used in accordance with the instructions, may cause harmful interference to radio communications.

However, there is no guarantee that interference will not occur in a particular installation. If this equipment does cause harmful interference to radio or television reception, which can be determined by turning the equipment off and on, the user is encouraged to try to correct the interference by one or more of the following measures:

- Reorient or relocate the receiving antenna.

- Increase the separation between the equipment and receiver.

- Connect the equipment into an outlet on a circuit different from that to which the receiver is connected.

- Consult the dealer or an experienced radio/TV technician for help.

This equipment complies with FCC radiation exposure limits set forth for an uncontrolled environment. This equipment should be installed and operated with minimum distance 20cm between the radiator & your body.