

FCC RADIO TEST REPORT

FCC ID: 2BDKCJF-H-40W

Sample : Treadmill remote control

Trade Mark : N/A

Main Model : JF-H-40W

Additional Model : N/A

Report No. : UNIA24010904ER-61

Prepared for

changsha jiuhui dianzishangwu youxiangongsi

Wangyueyuanjiedao furongzhongluyiduan466hao 1110-248hao

changshashi kaifuqu Changsha China

Prepared by

Shenzhen United Testing Technology Co., Ltd.

D101&D401, No. 107, Kaicheng High-Tech Park, Taoyuan Community,
Dalang Sub-District, Longhua District, Shenzhen, Guangdong, China

TEST RESULT CERTIFICATION

Applicant.....: changsha jiuhui dianzishangwu youxiangongsi
Address.....: Wangyueyuanjiedao furongzhongluyiduan466hao 1110-248hao
changshashi kaifuqu Changsha China

Manufacturer.....: Ningbo Jiufeng Electrical Appliance Co.,Ltd.
Address.....: No.268 Binhai road,Binhai New Area,FengHua economic
development zone,Ningbo,Zhejiang,China

Product description

Product.....: Treadmill remote control

Trade Mark.....: N/A

Model Name.....: JF-H-40W

Test Methods.....: FCC Part 15 Subpart C 15.231
ANSI C63.10: 2013

This device described above has been tested by Shenzhen United Testing Technology Co., Ltd., and the test results show that the equipment under test (EUT) is in compliance with the FCC requirements. And it is applicable only to the tested sample identified in the report.

This report shall not be reproduced except in full, without the written approval of UNI, this document may be altered or revised by Shenzhen United Testing Technology Co., Ltd., personnel only, and shall be noted in the revision of the document.

Date of Test

Date (s) of performance of tests.....: Jan. 09, 2024 ~ Feb. 28, 2024

Date of Issue.....: Feb. 29, 2024

Test Result.....: Pass

Prepared by:



Jason Ye/Editor

Reviewer:



Kelly Cheng/Supervisor

Approved & Authorized Signer:

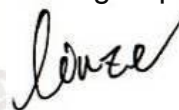

Liuze/Manager

Table of Contents

Pages

1	TEST SUMMARY	4
1.1	TEST PROCEDURES AND RESULTS	4
1.2	TEST FACILITY	5
1.3	MEASUREMENT UNCERTAINTY	6
2	GENERAL INFORMATION	7
2.1	GENERAL DESCRIPTION OF EUT	7
2.2	CARRIER FREQUENCY OF CHANNELS	8
2.3	OPARATION OF EUT DURING TESTING	8
2.4	DESCRIPTION OF TEST SETUP.....	8
2.5	ENVIRONMENTAL CONDITIONS	8
2.6	MEASUREMENT INSTRUMENTS LIST.....	9
3	CONDUCTED EMISSIONS TEST	10
4	RADIATED EMISSION TEST	11
5	-20DB OCCUPIED BANDWIDTH	18
6	DEACTIVATION TIME	19
6	ANTENNA REQUIREMENT	20
7	PHOTOGRAPH OF TEST	21

1 TEST SUMMARY

1.1 TEST PROCEDURES AND RESULTS

FCC Requirements		
FCC Part 15.207	Conducted Emission	Not applicable
FCC §15.231(a)(1)	Automatically Deactivate	PASS
FCC §15.231	Duty Cycle	PASS
FCC Part 15.231(b)	Electric Field Strength of Fundamental Emission	PASS
FCC Part 15.205 & 15.209 & 15.231(b)	Electric Field Strength of Spurious Emission	PASS
FCC Part 15.231(c)	-20dB bandwidth	PASS

1.2 TEST FACILITY

Test Firm : Shenzhen United Testing Technology Co., Ltd.
Address : D101&D401, No. 107, Kaicheng High-Tech Park, Taoyuan Community,
Dalang Sub-District, Longhua District, Shenzhen, Guangdong, China

The testing quality ability of our laboratory meet with "Quality Law of People's Republic of China" Clause 19. The testing quality system of our laboratory meets with ISO/IEC-17025 requirements. This approval result is accepted by MRA of APLAC.

Our test facility is recognized, certified, or accredited by the following organizations:

A2LA Certificate Number: 4747.01

The EMC Laboratory has been accredited by A2LA, and in compliance with ISO/IEC 17025:2017 General Requirements for testing Laboratories.

FCC Registration Number: 674885

The EMC Laboratory has been registered and fully described in a report filed with the (FCC) Federal Communications commission.

IC Registration Number: 31584

The EMC Laboratory has been registered and fully described in a report filed with the (IC) Industry Canada.

1.3 MEASUREMENT UNCERTAINTY

The reported uncertainty of measurement $y \pm U$, where expanded uncertainty U is based on a standard uncertainty multiplied by a coverage factor of $k=2$, providing a level of confidence of approximately 95 %.

A. Conducted Measurement:

Test Site	Method	Measurement Frequency Range	U, (dB)	NOTE
UNI	ANSI	9kHz ~ 150kHz	2.96	
		150kHz ~ 30MHz	2.44	

B. Radiated Measurement:

Test Site	Method	Measurement Frequency Range	U, (dB)	NOTE
UNI	ANSI	9kHz ~ 30MHz	2.50	
		30MHz ~ 1000MHz	4.80	
		1000MHz ~ 18000MHz	4.13	

2 GENERAL INFORMATION

2.1 GENERAL DESCRIPTION OF EUT

The following information of EUT submitted and identified by applicant:

Product:	Treadmill remote control
Trade Mark:	N/A
Main Model:	JF-H-40W
Additional Model:	N/A
Model Difference:	N/A
FCC ID:	2BDKCJF-H-40W
Field Strength of Fundamental:	71.13dBuV/m(Peak)@3m
Antenna Type:	PCB Antenna
Antenna Gain:	0dBi
Frequency Range:	433.92MHz
Number of Channels:	1CH
Modulation Type:	ASK
Battery:	DC 3V
Power Source:	DC 3V from battery

2.2 CARRIER FREQUENCY OF CHANNELS

Channel	Frequency(MHz)
1	433.92

2.3 OPERATION OF EUT DURING TESTING

New battery is used during all test
 Operating Mode
 The mode is used: Transmitting mode

2.4 DESCRIPTION OF TEST SETUP

Operation of EUT during Radiation testing:



Table for auxiliary equipment:

Equipment Description	Manufacturer	Model	Calibration Due Date
N/A	N/A	N/A	N/A

2.5 ENVIRONMENTAL CONDITIONS

During the measurement the environmental conditions were within the listed ranges:

Temperature	Normal Temperature:	26°C
Voltage	Normal Voltage	3 V
Other	Relative Humidity	55 %
	Air Pressure	101 kPa

2.6 MEASUREMENT INSTRUMENTS LIST

Item	Equipment	Manufacturer	Model No.	Serial No.	Calibrated until
Radiated Emissions Measurement					
1	Radiated Emission Test Software	EZ-EMC	Ver.CCS-03A1	N/A	N/A
2	Horn Antenna	Sunol	DRH-118	A101415	2025.07.14
3	Broadband Hybrid Antenna	Sunol	JB1	A090215	2025.07.28
4	PREAMP	HP	8449B	3008A00160	2024.06.11
5	PREAMP	HP	8447D	2944A07999	2024.06.11
6	EMI TEST RECEIVER	Rohde&Schwarz	ESR3	101891	2024.06.11
7	VECTOR Signal Generator	Rohde&Schwarz	SMU200A	101521	2024.06.11
8	Signal Generator	Agilent	E4421B	MY4335105	2024.06.11
9	MXA Signal Analyzer	Agilent	N9020A	MY50510140	2024.06.11
10	MXA Signal Analyzer	Keysight	N9020A	MY51110104	2024.06.11
11	RF Power sensor	DARE	RPR3006W	15I00041SNO88	2024.06.11
12	RF Power sensor	DARE	RPR3006W	15I00041SNO89	2024.06.11
13	RF power divider	Anritsu	K241B	992289	2024.06.11
14	Wideband radio communication tester	Rohde&Schwarz	CMW500	154987	2024.06.11
15	Active Loop Antenna	Com-Power	AL-130R	10160009	2024.06.11
16	Broadband Hybrid Antennas	Schwarzbeck	VULB9163	VULB9163#958	2024.09.22
17	Horn Antenna	Schwarzbeck	BBHA9120D	9120D-1680	2025.07.14
18	Horn Antenna	A-INFOMW	LB-180400-KF	J211060660	2024.07.14
19	Microwave Broadband Preamplifier	Schwarzbeck	BBV 9721	100472	2024.09.22
20	Signal Generator	Agilent	N5183A	MY47420153	2024.09.22
21	Spectrum Analyzer	Rohde&Schwarz	FSP 40	100501	2024.09.22
22	Power Meter	KEYSIGHT	N1911A	MY50520168	2024.09.22
23	Frequency Meter	VICTOR	VC2000	997406086	2024.09.22
24	DC Power Source	HYELEC	HY5020E	055161818	2024.09.22

3 CONDUCTED EMISSIONS TEST

3.1 Limit

For unintentional device, according to § 15.107(a) Line Conducted Emission Limits is as following

Frequency range (MHz)	Limit (dBuV)	
	Quasi-peak	Average
0.15-0.5	66 to 56*	56 to 46*
0.5-5	56	46
5-30	60	50

* Decreasing linearly with the logarithm of the frequency

For intentional device, according to §15.207(a) Line Conducted Emission Limit is same as above table.

3.2 Test Setup

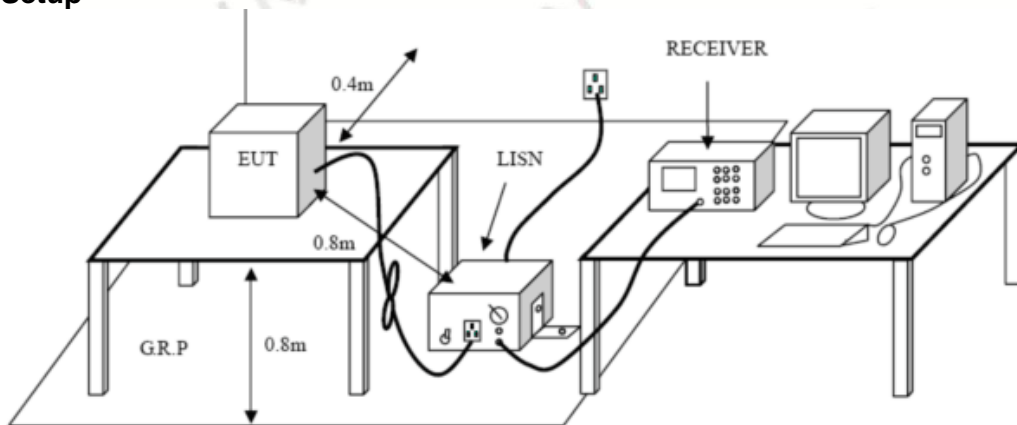

3.3 Test Procedure

- 1, The equipment was set up as per the test configuration to simulate typical actual usage per the user's manual. A wooden table with a height of 0.8 meters is used and is placed on the ground plane as per ANSI C63.10.
- 2, Support equipment, if needed, was placed as per ANSI C63.10.
- 3, All I/O cables were positioned to simulate typical actual usage as per ANSI C63.10.
- 4, If a EUT received DC power from the USB Port of Notebook PC, the PC's adapter received AC120V/60Hz power through a Line Impedance Stabilization Network (LISN) which supplied power source and was grounded to the ground plane.
- 5, All support equipments received AC power from a second LISN, if any.
- 6, The EUT test program was started. Emissions were measured on each current carrying line of the EUT using a spectrum Analyzer / Receiver connected to the LISN powering the EUT. The LISN has two monitoring points: Line 1 (Hot Side) and Line 2 (Neutral Side). Two scans were taken: one with Line 1 connected to Analyzer / Receiver and Line 2 connected to a 50 ohm load; the second scan had Line 1 connected to a 50 ohm load and Line 2 connected to the Analyzer / Receiver.
- 7, Analyzer / Receiver scanned from 150 KHz to 30MHz for emissions in each of the test modes.

3.4 Test Result

N/A

Remark:

The EUT is powered by DC 3V battery.

4 RADIATED EMISSION TEST

4.1 Limit

For unintentional device, according to § 15.109(a), except for Class A digital devices, the field strength of radiated emissions from unintentional radiators at a distance of 3 meters shall not exceed the following values:

Frequency (MHz)	Distance (Meters)	Radiated (dBµV/m)	Radiated (µV/m)
30-88	3	40	100
88-216	3	43.5	150
216-960	3	46	200
Above 960	3	54	500

For intentional device, according to § 15.209(a), the general requirement of field strength of radiated emissions from intentional radiators at a distance of 3 meters shall not exceed the above table.

In addition to the provisions of 15.231(b) and RSS 210-A1.1.2, the field strength of emissions from intentional radiators operated under this section shall not exceed the following:

Funda-mental fre- quency (MHz)	Field strength of funda- mental (microvolts/ meter)	Field strength of spurious emissions (microvolts/meter)
40.66– 40.70.	2,250	225
70–130	1,250	125
130–174	¹ 1,250 to 3,750	¹ 125 to 375
174–260	3,750	375
260–470	¹ 3,750 to 12,500	¹ 375 to 1,250
Above 470	12,500	1,250

¹ Linear interpolations.

[Where F is the frequency in MHz, the formulas for calculating the maximum permitted fundamental field strengths are as follows: for the band 260-470 MHz, µV/m at 3 meters = 41.6667(F) - 7083.3333.

The maximum permitted unwanted emission level is 20 dB below the maximum permitted fundamental level.]

4.2 Test Setup

1. Radiated Emission Test-Up Frequency Below 30MHz

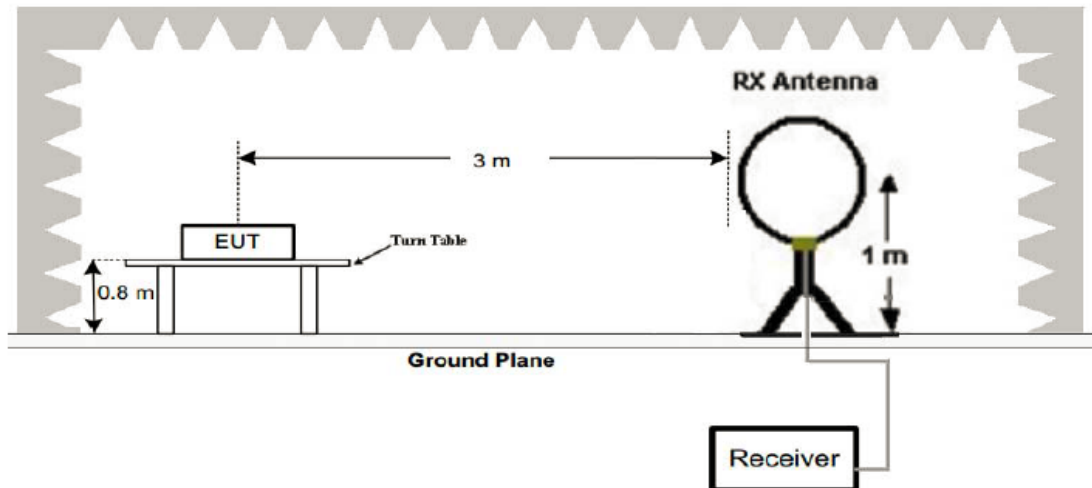

2. Radiated Emission Test-Up Frequency 30MHz~1GHz

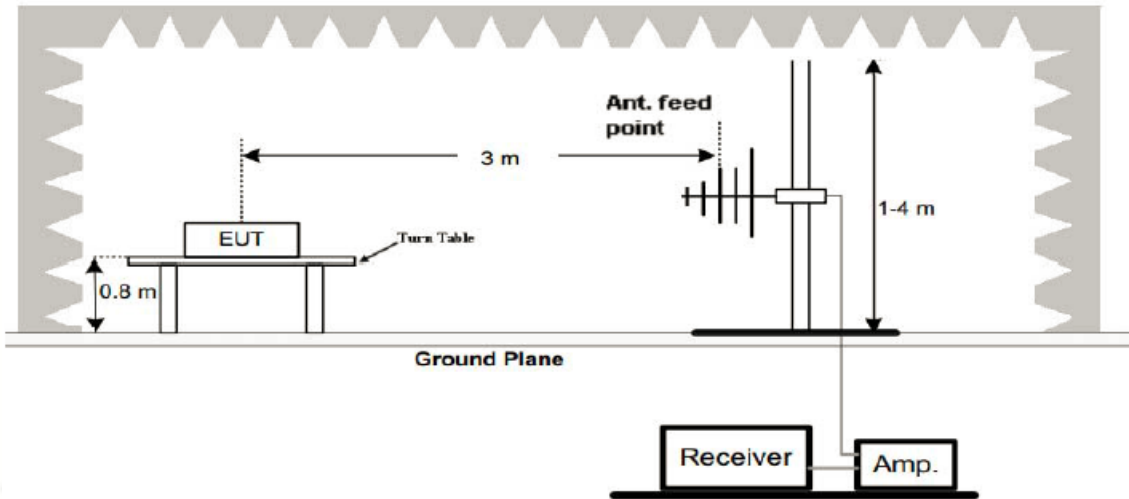

3. Radiated Emission Test-Up Frequency Above 1GHz

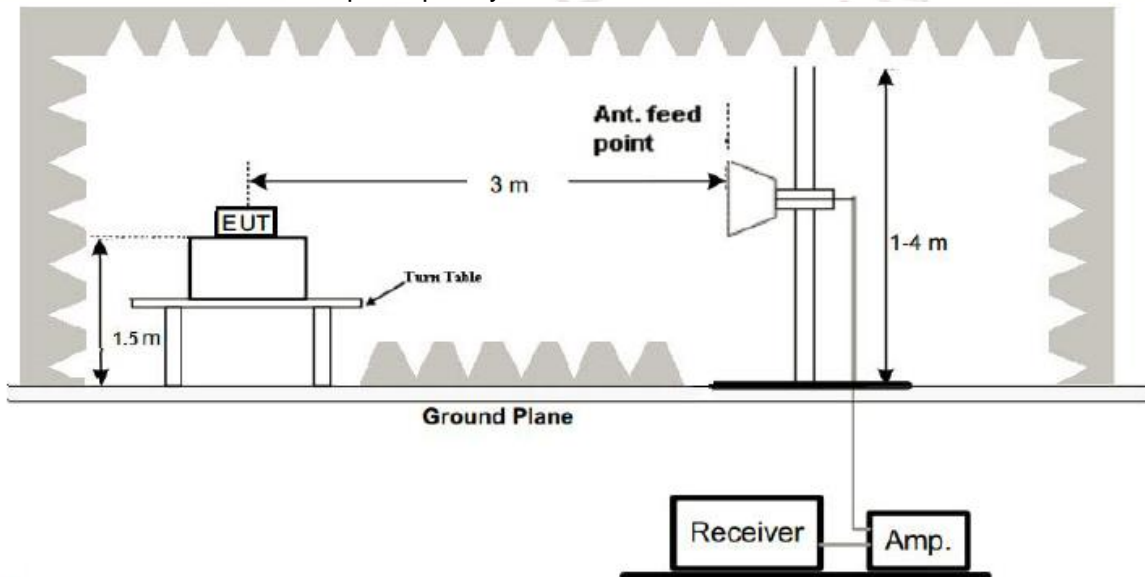

4.3 Test Procedure

1. Below 1GHz measurement the EUT is placed on turntable which is 0.8m above ground plane. And above 1GHz measurement EUT was placed on low permittivity and low tangent turn table which is 1.5m above ground plane.
2. The turntable shall be rotated for 360 degrees to determine the position of maximum emission level.
3. EUT is set 3m away from the receiving antenna, which is varied from 1m to 4m to find out the highest emissions.
4. Maximum procedure was performed on the six highest emissions to ensure EUT compliance.
5. And also, each emission was to be maximized by changing the polarization of receiving antenna both horizontal and vertical.
6. Repeat above procedures until the measurements for all frequencies are complete.
7. The test frequency range from 9kHz to 25GHz per FCC PART 15.33(a).

Note:

For battery operated equipment, the equipment tests shall be performed using a new battery.

4.4 Test Result

PASS

Remark:

1. By preliminary testing and verifying three axis (X, Y and Z) position of EUT transmitted status, it was found that "Z axis" position was the worst, and test data recorded in this report.
2. Radiated emission test from 9KHz to 10th harmonic of fundamental was verified, and no emission found except system noise floor in 9KHz to 30MHz and not recorded in this report.

T_{on} (ms)	$T_{on}+T_{off}$ (ms)
$10*1.198+15*0.3746=17.599$	50.20
Duty cycle factor (dB)= $20\log(T_{on} / (T_{on} + T_{off}))$ (dB) = -9.10(dB)	

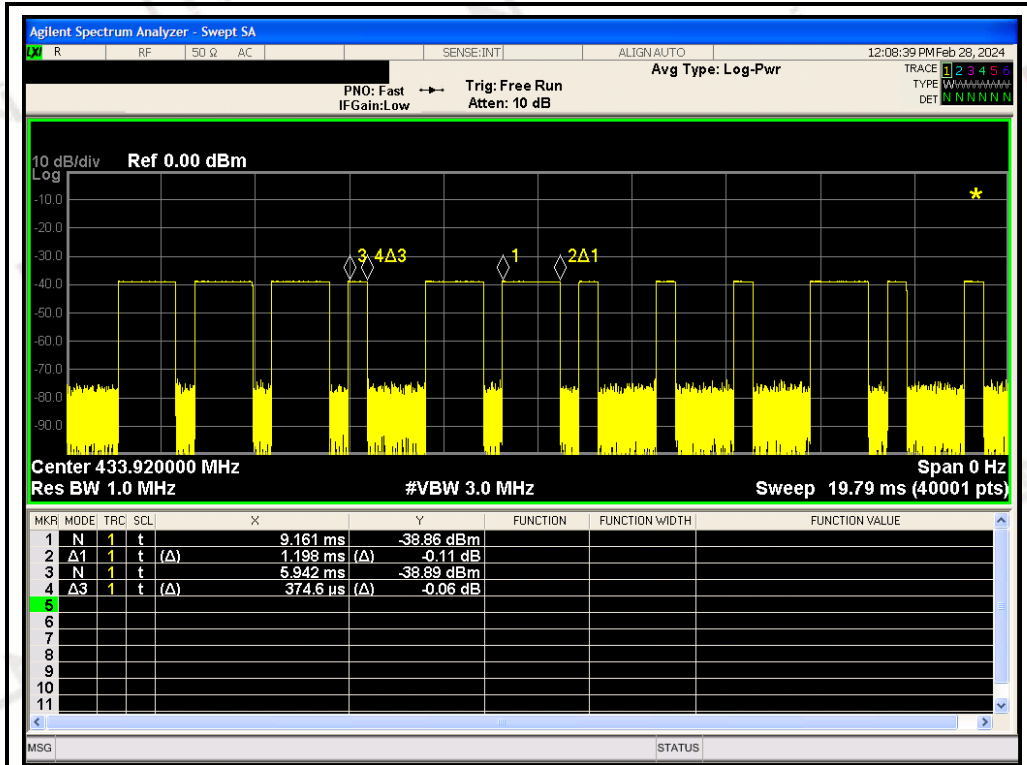

Pulse 1

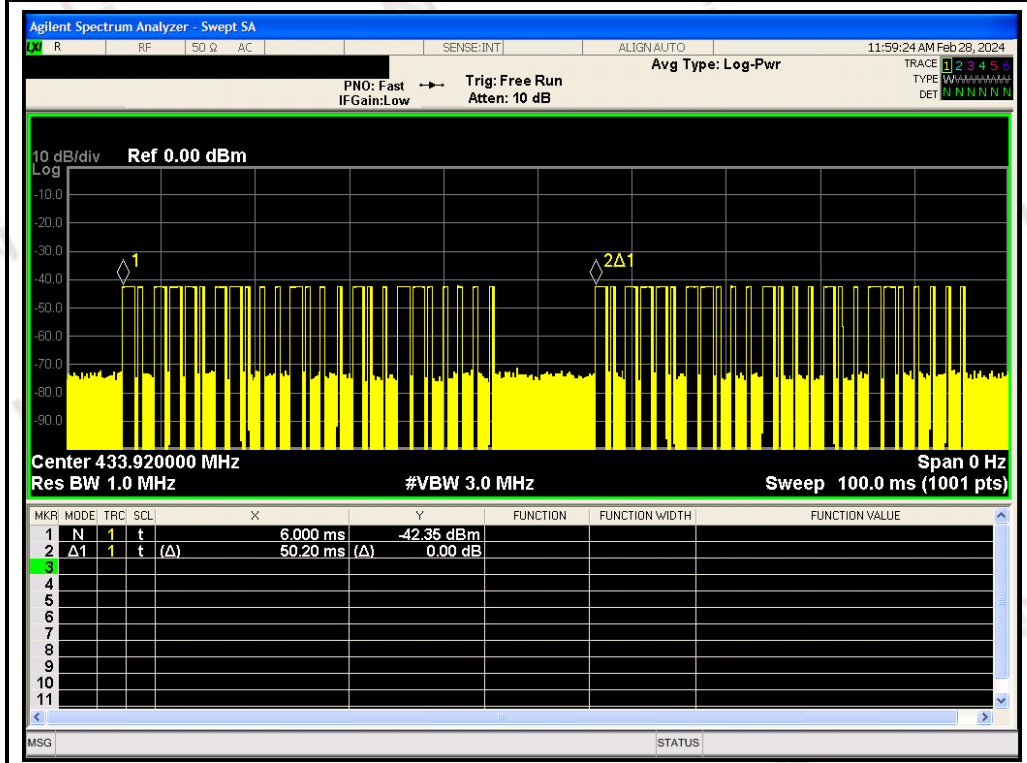

$T_{on} + T_{off}$

Below 1GHz Test Results:

Temperature:	24°C	Relative Humidity:	49%
Test Date:	Jan. 12, 2024	Pressure:	1010hPa
Test Voltage:	DC 3V	Polarization:	Horizontal
Test Mode:	Transmitting mode of 433.92MHz		

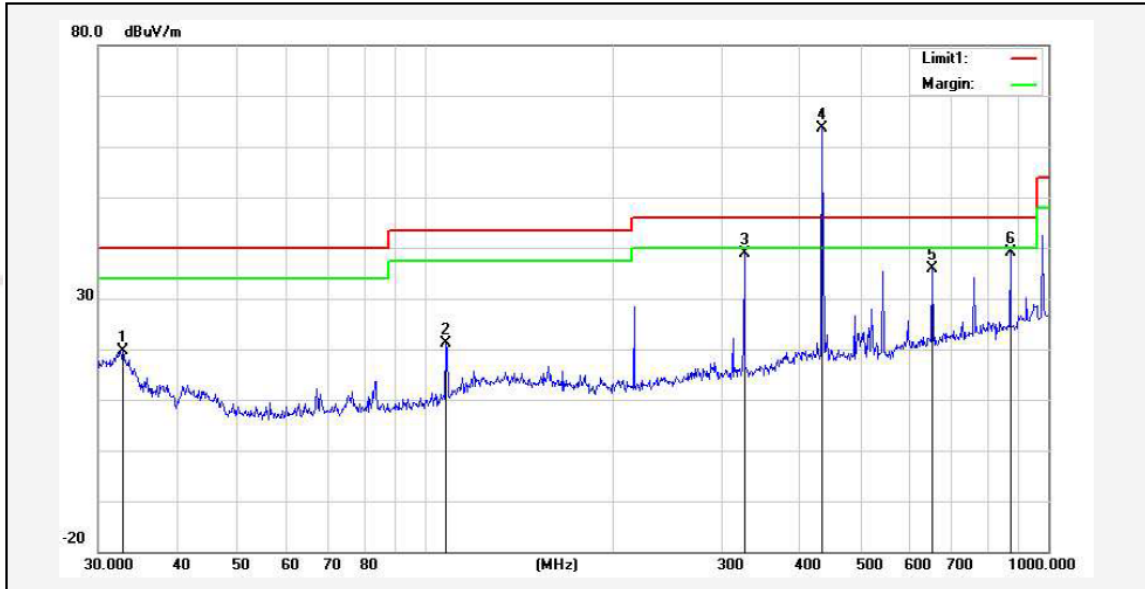

No.	Frequency (MHz)	Reading (dBuV)	Correction factor(dB/m)	Result (dBuV/m)	Limit (dBuV/m)	Margin (dB)	Degree (deg.)	Height (cm)	Remark
1	32.8637	34.44	-14.83	19.61	40.00	-20.39	66	100	peak
2	108.2667	38.89	-17.77	21.12	43.50	-22.38	39	100	peak
3	325.5957	52.52	-13.52	39.00	46.00	-7.00	45	100	peak
4*	433.9250	75.95	-12.33	63.62	100.53	-36.91	86	100	peak
5	651.9415	44.98	-9.13	35.85	46.00	-10.15	105	100	peak
6	867.8164	44.48	-5.44	39.04	80.53	-41.49	78	100	peak

Remark: Result= Reading Level+ Factor, Margin= Result – Limit
 Factor=Ant. Factor + Cable Loss – Pre-amplifier

Temperature:	24°C	Relative Humidity:	49%
Test Date:	Jan. 12, 2024	Pressure:	1010hPa
Test Voltage:	DC 3V	Polarization:	Vertical
Test Mode:	Transmitting mode of 433.92MHz		

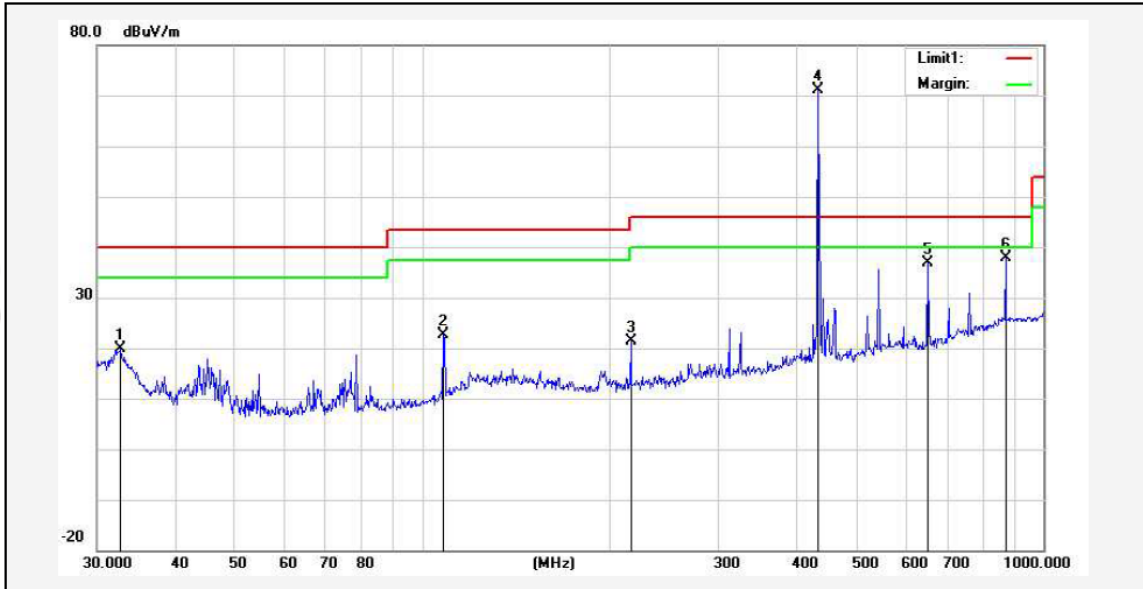

No.	Frequency (MHz)	Reading (dBuV)	Correction factor(dB/m)	Result (dBuV/m)	Limit (dBuV/m)	Margin (dB)	Degree (deg.)	Height (cm)	Remark
1	32.7486	34.77	-14.77	20.00	40.00	-20.00	24	100	peak
2	108.2667	40.51	-17.77	22.74	43.50	-20.76	73	100	peak
3	216.7828	37.44	-15.97	21.47	46.00	-24.53	116	100	peak
4*	433.9250	83.46	-12.33	71.13	100.53	-29.40	41	100	peak
5	651.9416	45.93	-9.13	36.80	46.00	-9.20	65	100	peak
6	867.8164	43.24	-5.44	37.80	80.53	-42.73	109	100	peak

Remark: Result = Reading Level+ Factor, Margin= Result – Limit
 Factor=Ant. Factor + Cable Loss – Pre-amplifier

Frequency (MHz)	Peak Level (dBuV/m)	Duty cycle factor(dB)	AV Level (dBuV/m)	FCC Limit (dBuV/m)	Margin (dB)	Polarization
433.9250	63.62	-9.10	54.52	80.53	-26.01	Vertical
867.8164	39.04	-9.10	29.94	60.53	-30.59	Vertical
433.9250	71.13	-9.10	62.03	80.53	-18.50	Horizontal
867.8164	37.80	-9.10	28.70	60.53	-31.83	Horizontal

Above 1 GHz Test Results:

Horizontal:

Frequency (MHz)	Reading Result (dBμV)	Factor (dB)	Emission Level (dBμV/m)	Limits (dBμV/m)	Margin (dB)	Detector Type
1301.84	48.59	-5.34	43.25	60.53	-17.28	PK
1735.72	48.83	-5.02	43.81	60.53	-16.72	PK
2169.68	50.18	-4.76	45.42	60.53	-15.11	PK

Remark: Factor = Antenna Factor + Cable Loss – Pre-amplifier. Margin= Emission Level – Limit

Vertical:

Frequency (MHz)	Reading Result (dBμV)	Factor (dB)	Emission Level (dBμV/m)	Limits (dBμV/m)	Margin (dB)	Detector Type
1301.84	48.11	-5.34	42.77	60.53	-17.76	PK
1735.72	48.75	-5.02	43.73	60.53	-16.80	PK
2169.68	50.03	-4.76	45.27	60.53	-15.26	PK

Remark: Factor = Antenna Factor + Cable Loss – Pre-amplifier. Margin= Emission Level – Limit

- Note: 1. Testing is carried out with frequency rang 30MHz to the tenth harmonics, which above 5th Harmonics are attenuated more than 20dB below the permissible limits or the field strength is too small to be measured.
 2. The fundamental frequency is 433.92MHz, so the fundamental and spurious emissions radiated limit base on the operating frequency 433.92MHz.
 3. Since the peak value is less than the average limit, the average value does not need to be tested.

5 -20db OCCUPIED BANDWIDTH

5.1 Limit

According to 47 CFR 15.231(c) The bandwidth of the emission shall be no wider than 0.25% of the centre frequency for devices operating above 70MHz and below 900MHz. Bandwidth is determined at the points 20dB down from the modulated carrier.

5.2 Test Procedure

The transmitter output was connected to the spectrum analyzer through an attenuator. The bandwidth of the fundamental frequency was measured by spectrum analyzer with RBW=1%-5%OBW, VBW=3RBW, Span= 2*OBW~5*OBW.

The 20dB bandwidth is defined as the total spectrum the power of which is higher than peak power minus 20dB.

5.3 Test Configuration

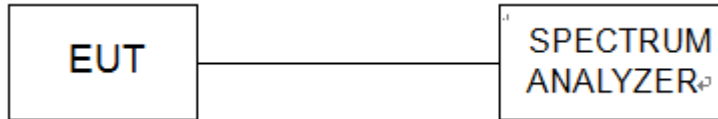

5.4 Test Result

PASS

Modulation	Channel Frequency (MHz)	99% OBW (KHz)	20dB bandwidth (KHz)	Limit (KHz)	Result
ASK	433.92	717.42	42.96	0.25%*433920=1084.8	Pass

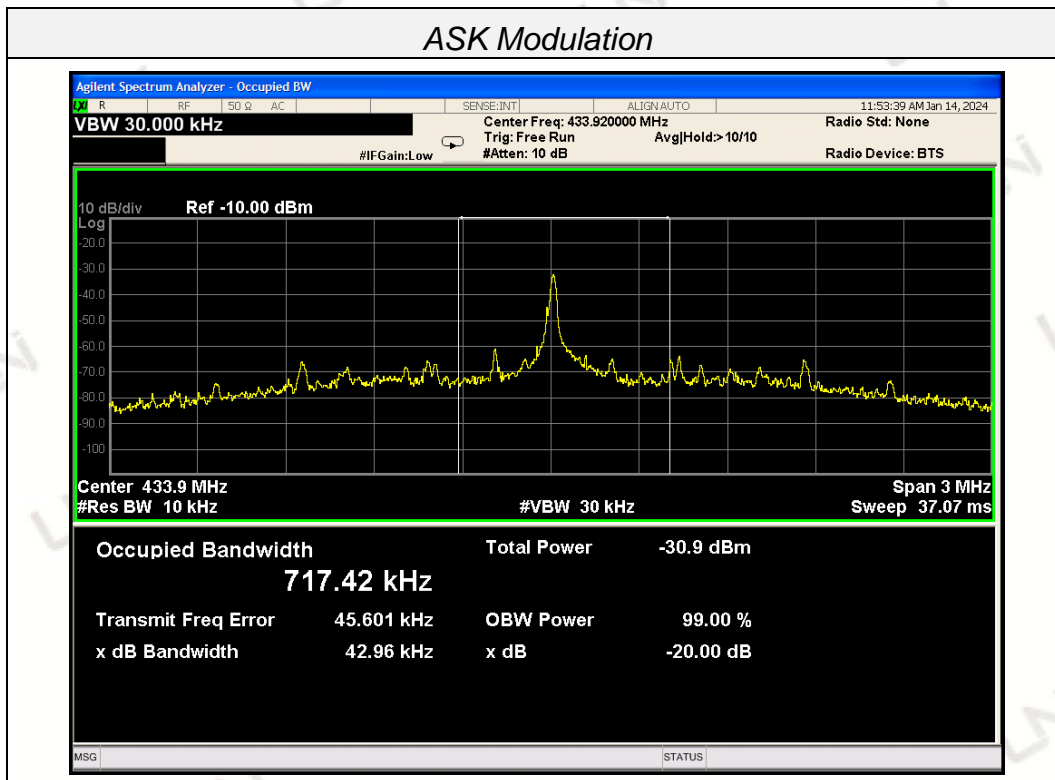

6 DEACTIVATION TIME

6.1 Limit

According to FCC §15.231(a)(1), A transmitter activated automatically shall cease transmission within 5 seconds after activation.

6.2 Test Procedure

1. The EUT was placed on a wooded table which is 0.8m height and close to receiver antenna of spectrum analyzer.
2. The spectrum analyzer resolution bandwidth was set to 1 MHz and video bandwidth was set to 1 MHz to encompass all significant spectral components during the test. The spectrum analyzer was operated in linear scale and zero span mode after tuning to the transmitter carrier frequency.

6.3 Test Configuration



6.4 Test Results

Frequency(MHz)	One transmission time(s)	Limit(s)	Result
433.92	0.240	5	Pass

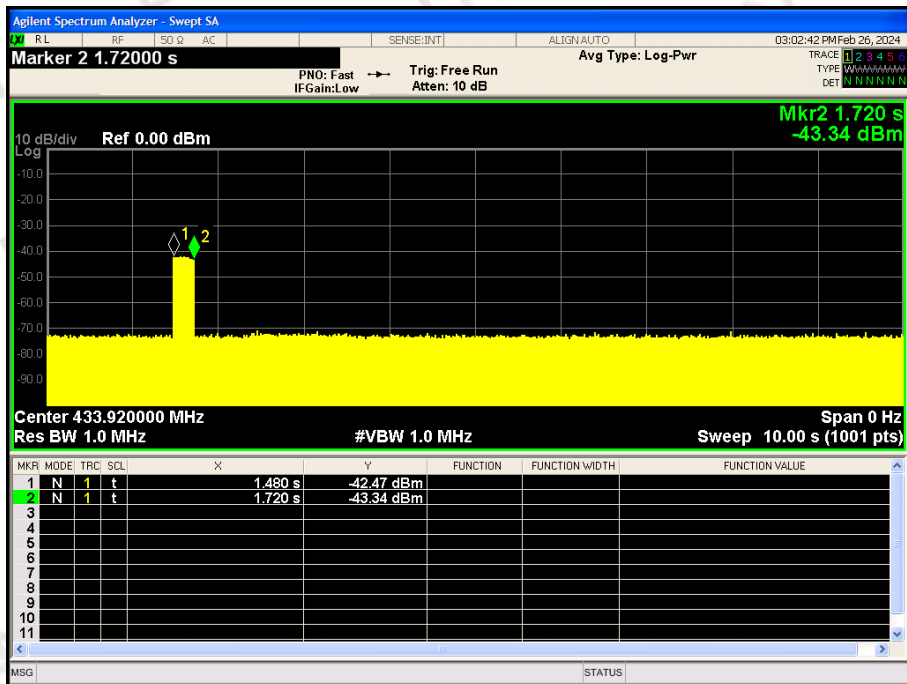

6 ANTENNA REQUIREMENT

Standard Applicable:

For intentional device, according to FCC 47 CFR Section 15.203, an intentional radiator shall be designed to ensure that no antenna other than that furnished by the responsible party shall be used with the device.

Antenna Connected Construction

The antenna used in this product is a PCB antenna, the directional gains of antenna used for transmitting is 0dBi. It is permanently fixed and cannot be disassembled.

ANTENNA:

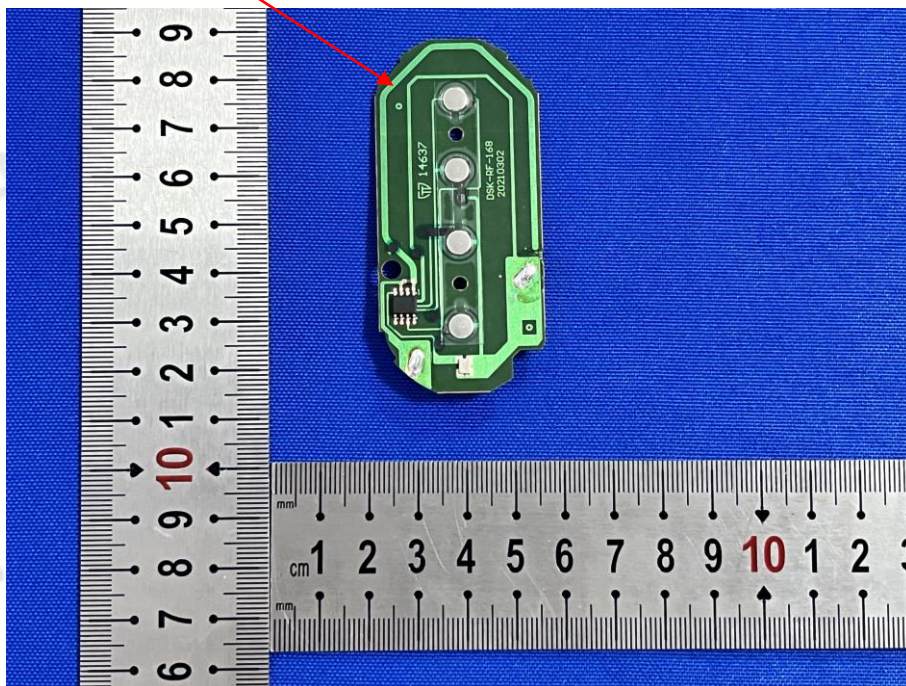

7 PHOTOGRAPH OF TEST Radiated Emission

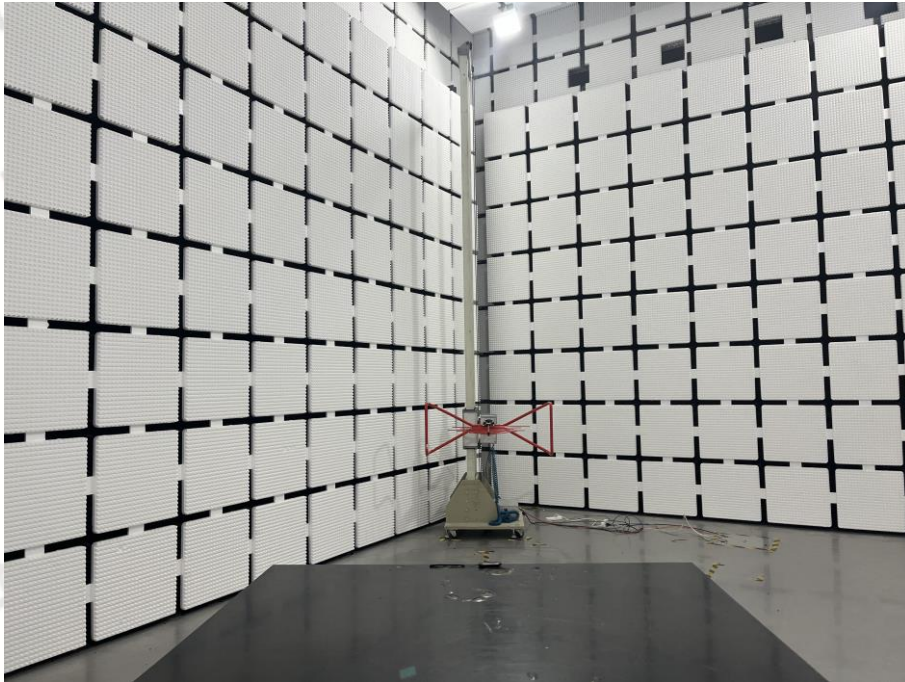

*****End of Report*****