



FCC Test Report

**Test report
On Behalf of
Shenzhen Haimeilan Technology Co., LTD.
For
Smart Phone**

**Model No.: K60, F5 Pro, F50 Pro, K60 Pro, K60E, M13, M13 Pro,
M5s Pro, M5s, X5 Pro, F3 Pro, X40, X40 Pro, X40 Edge, F5,
Note12 Pro, M6 Pro, I14 Pro max, I15 Pro max, G14 Pro, S22Ultra,
S23 Ultra, G22**

FCC ID: 2BDI3-K60

Prepared For : Shenzhen Haimeilan Technology Co., LTD.
9V777, East 9th Floor, Building 2, SEG Science Park, Huaqiang North Street,
Futian District, Shenzhen, 518000 China

Prepared By : Shenzhen HUAK Testing Technology Co., Ltd.
1-2/F., Building B2, Junfeng Zhongcheng Zhizao Innovation Park, Heping,
Fuhai Street, Bao'an District, Shenzhen, Guangdong, China

Date of Test: Aug. 23, 2023 ~ Nov. 13, 2023

Date of Report: Nov. 13, 2023

Report Number: HK2308233869-8E



Test Result Certification

Applicant's name: Shenzhen Haimeilan Technology Co., LTD.
Address: 9V777, East 9th Floor, Building 2, SEG Science Park, Huaqiang North Street, Futian District, Shenzhen, 518000 China

Manufacture's Name.....: Shenzhen Shengkai Technology Co., Ltd.
Address: 4th floor, Building 7, Hongye Industrial Park, Zhujiào Village, Hangcheng Street, Baoan District, Shenzhen, 518000, China

Product description

Trade Mark: N/A

Product name.....: Smart Phone

Model and/or type reference : K60, F5 Pro, F50 Pro, K60 Pro, K60E, M13, M13 Pro, M5s Pro, M5s, X5 Pro, F3 Pro, X40, X40 Pro, X40 Edge, F5, Note12 Pro, M6 Pro, I14 Pro max, I15 Pro max, G14 Pro, S22Ultra, S23 Ultra, G22

Standards: FCC Rules and Regulations Part 15 Subpart E Section 15.407
ANSI C63.10: 2013

This publication may be reproduced in whole or in part for non-commercial purposes as long as the Shenzhen HUAK Testing Technology Co., Ltd. is acknowledged as copyright owner and source of the material. Shenzhen HUAK Testing Technology Co., Ltd. takes no responsibility for and will not assume liability for damages resulting from the reader's interpretation of the reproduced material due to its placement and context.

Date of Test.....:

Date (s) of performance of tests: **Aug. 23, 2023 ~ Nov. 13, 2023**

Date of Issue.....: **Nov. 13, 2023**

Test Result.....: **Pass**

Prepared by: *Gang Dian*

Project Engineer

Reviewed by: *Zden Hu*

Project Supervisor

Approved by: *Jason Zhou*

Technical Director



Table of Contents

- 1. Test Result Summary 5**
 - 1.1. Test Procedures and Results 5
 - 1.2. Information of the Test Laboratory 5
 - 1.3. Measurement Uncertainty 6
- 2. EUT Description 7**
 - 2.1. General Description of EUT 7
 - 2.2. Operation Frequency Each of Channel 8
 - 2.3. Operation of EUT During Testing 8
 - 2.4. Description of Test Setup 9
 - 2.5. Description of Support Units 10
- 3. Genera Information 11**
 - 3.1. Test Environment and Mode 11
- 4. Test Results and Measurement Data 14**
 - 4.1. Conducted Emission 14
 - 4.2. Maximum Conducted Output Power 18
 - 4.3. 6db Emission Bandwidth 21
 - 4.4. 26db Bandwidth and 99% Occupied Bandwidth 22
 - 4.5. Power Spectral Density 29
 - 4.6. Band Edge 36
 - 4.7. Spurious Emission 49
 - 4.8. Frequency Stability Measurement 57
 - 4.9. Antenna Requirement 60
- 5. Photographs of Test Setup 61**
- 6. Photos of the EUT 63**



**** Modified History ****

Revision	Description	Issued Data	Remark
Revision 1.0	Initial Test Report Release	Nov. 13, 2023	Jason Zhou



1. Test Result Summary

1.1. Test Procedures and Results

Requirement	CFR 47 Section	Result
Antenna requirement	§15.203	PASS
AC Power Line Conducted Emission	§15.207	PASS
Maximum Conducted Output Power	§15.407(a)	PASS
6dB Emission Bandwidth	§15.407(e)	N/A
26dB Emission Bandwidth & 99% Occupied Bandwidth	§15.407(a)	PASS
Power Spectral Density	§15.407(a)	PASS
Band edge	§15.407(b)/15.209/15.205	PASS
Radiated Emission	§15.407(b)/15.209/15.205	PASS
Frequency Stability	§15.407(g)	PASS

Note:

1. PASS: Test item meets the requirement.
2. Fail: Test item does not meet the requirement.
3. N/A: Test case does not apply to the test object.
4. The test result judgment is decided by the limit of test standard.

1.2. Information of the Test Laboratory

Shenzhen HUAKE Testing Technology Co., Ltd.
 Add.: 1-2/F., Building B2, Junfeng Zhongcheng Zhizao Innovation Park, Heping, Fuhai Street, Bao'an District, Shenzhen, Guangdong, China

Testing Laboratory Authorization:

A2LA Accreditation Code is 4781.01.
 FCC Designation Number is CN1229.
 Canada IC CAB identifier is CN0045.
 CNAS Registration Number is L9589.



1.3. Measurement Uncertainty

The reported uncertainty of measurement $y \pm U$, where expanded uncertainty U is based on a standard uncertainty multiplied by a coverage factor of $k=2$, providing a level of confidence of approximately 95 %.

No.	Item	MU
1	Conducted Emission	$\pm 2.71\text{dB}$
2	RF power, conducted	$\pm 0.37\text{dB}$
3	Spurious emissions, conducted	$\pm 0.11\text{dB}$
4	All emissions, radiated(<1G)	$\pm 3.90\text{dB}$
5	All emissions, radiated(>1G)	$\pm 4.28\text{dB}$
6	Temperature	$\pm 0.1^\circ\text{C}$
7	Humidity	$\pm 1.0\%$



2. EUT Description

2.1. General Description of EUT

Equipment:	Smart Phone
Model Name:	K60
Serial No.:	F5 Pro, F50 Pro, K60 Pro, K60E, M13, M13 Pro, M5s Pro, M5s, X5 Pro, F3 Pro, X40, X40 Pro, X40 Edge, F5, Note12 Pro, M6 Pro, I14 Pro max, I15 Pro max, G14 Pro, S22Ultra, S23 Ultra, G22
Trade Mark:	N/A
Model Difference:	All model's the function, software and electric circuit are the same, only with a product color, appearance and model named different. Test sample model: K60.
FCC ID:	2BDI3-K60
Operation Frequency:	IEEE 802.11a/n/ac (HT20) 5.180GHz-5.240GHz IEEE 802.11n/ac (HT40) 5.190GHz-5.230GHz
Modulation Technology:	IEEE 802.11a/n/ac
Modulation Type:	CCK/OFDM/DBPSK/DAPSK
Antenna Type:	Internal Antenna
Antenna Gain:	1.1dBi
Power Source:	DC 5V From Type-C or DC 3.8V From Battery
Power Supply:	DC 5V From Type-C or DC 3.8V From Battery



2.2. Operation Frequency Each of Channel

802.11a/802.11n/ 802.11ac (HT20)		802.11n/802.11ac (HT40)	
Channel	Frequency	Channel	Frequency
36	5180	38	5190
40	5200	46	5230
44	5220		
48	5240		

Note:

In section 15.31(m), regards to the operating frequency range over 10 MHz, the Lowest frequency, the middle frequency, and the highest frequency of channel were selected to perform the test, and the selected channel see below:

2.3. Operation of EUT During Testing

For 802.11a/n/ac (HT20)

Band I (5150 - 5250 MHz)		
Channel Number	Channel	Frequency (MHz)
36	Low	5180
40	Mid	5200
48	High	5240

For 802.11n/ac (HT40)

Band I (5150 - 5250 MHz)		
Channel Number	Channel	Frequency (MHz)
38	Low	5190
46	High	5230



2.4. Description of Test Setup

Operation of EUT during conducted testing and below 1GHz radiation testing:

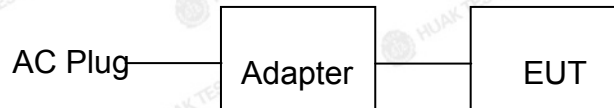

Operation of EUT during above 1GHz radiation testing:



The sample was placed (0.8m below 1GHz, 1.5m above 1GHz) above the ground plane of 3m chamber. Measurements in both horizontal and vertical polarities were performed. During the test, each emission was maximized by: having the EUT continuously working, investigated all operating modes, rotated about all 3 axis (X, Y & Z) and considered typical configuration to obtain worst position, manipulating interconnecting cables, rotating the turntable, varying antenna height from 1m to 4m in both horizontal and vertical polarizations. The emissions worst-case are shown in Test Results of the following pages. The worst case is X position.



2.5. Description of Support Units

The EUT has been tested as an independent unit together with other necessary accessories or support units. The following support units or accessories were used to form a representative test configuration during the tests.

Item	Equipment	Trade Mark	Model/Type No.	Specification	Remark
1	Smart Phone	N/A	K60	N/A	EUT
2	USB Cable	N/A	N/A	Length:1.02m	Accessory
3	Adapter	N/A	APD5-2	Input: AC 100-240V, 50/60Hz, 0.5A Output: 5VDC, 2.4A	Accessory
4	RF Cable	N/A	N/A	Length:0.1m	Peripheral

Note:

1. All the equipment/cables were placed in the worst-case configuration to maximize the emission during the test.
2. Grounding was established in accordance with the manufacturer's requirements and conditions for the intended use.
3. For conducted measurements (Output Power, 20dB and 99% Bandwidth, Power Spectral Density, Spurious Emissions), the antenna of EUT is connected to the test equipment via temporary antenna connector, the antenna connector is soldered on the antenna port of EUT, and the temporary antenna connector is listed in the Test Instruments.



3. Genera Information

3.1. Test Environment and Mode

Operating Environment:	
Temperature:	25.0 °C
Humidity:	56 % RH
Atmospheric Pressure:	1010 mbar
Test Mode:	
Engineering mode:	Keep the EUT in continuous transmitting by select channel and modulations
<p>The sample was placed 0.8m/1.5m for blow/above 1GHz above the ground plane of 3m chamber. Measurements in both horizontal and vertical polarities were performed. During the test, each emission was maximized by: having the EUT continuously working, investigated all operating modes, rotated about all 3 axis (X, Y & Z) and considered typical configuration to obtain worst position, manipulating interconnecting cables, rotating the turntable, varying antenna height from 1m to 4m in both horizontal and vertical polarizations. The emissions worst-case are shown in Test Results of the following pages.</p>	





We have verified the construction and function in typical operation. All the test modes were carried out with the EUT in transmitting operation, which was shown in this test report and defined as follows:

Per-scan all kind of data rate in lowest channel, and found the follow list which it was worst case.

Mode	Data rate
802.11a	6 Mbps
802.11n/ac(HT20)	MCS0
802.11n/ac(HT40)	MCS0

Final Test Mode:

Operation mode:	Keep the EUT in continuous transmitting with modulation
-----------------	---

Mode Test Duty Cycle:

Mode	Duty Cycle	Duty Cycle Factor (dB)
802.11a	0.98	-0.09
802.11n(HT20)	0.98	-0.09
802.11n(HT40)	0.94	-0.27
802.11ac(HT20)	0.97	-0.13
802.11ac(HT40)	0.96	-0.18

Test plots as follows:

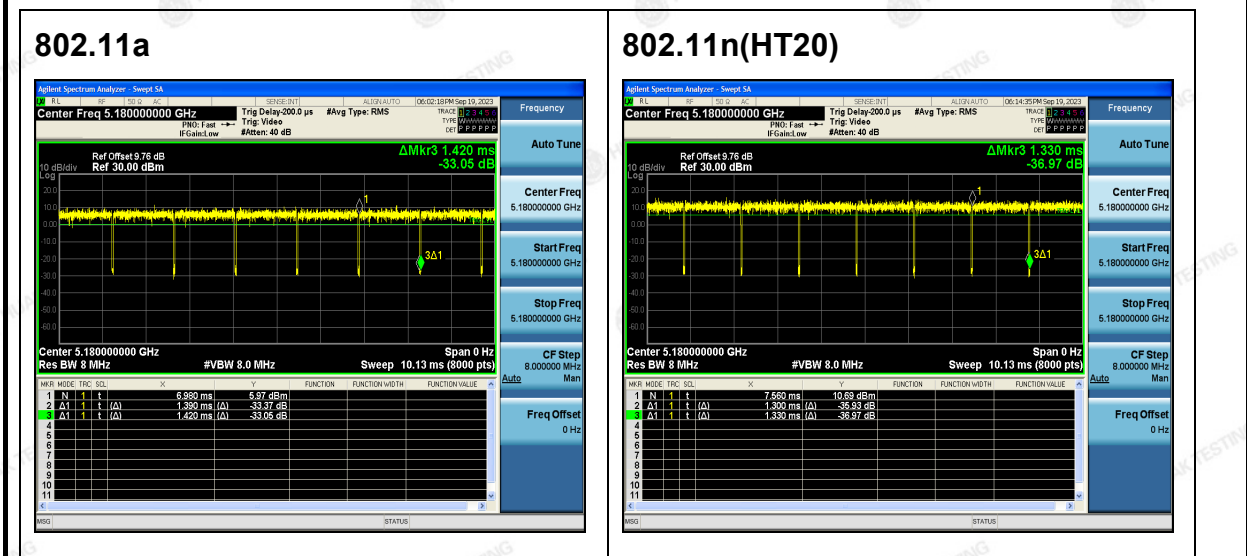



802.11n(HT40)

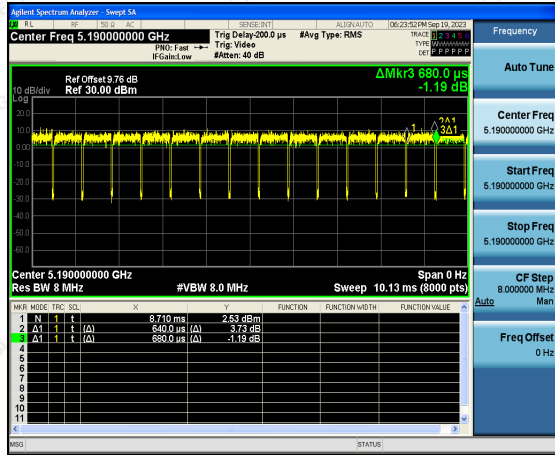

802.11ac(HT20)

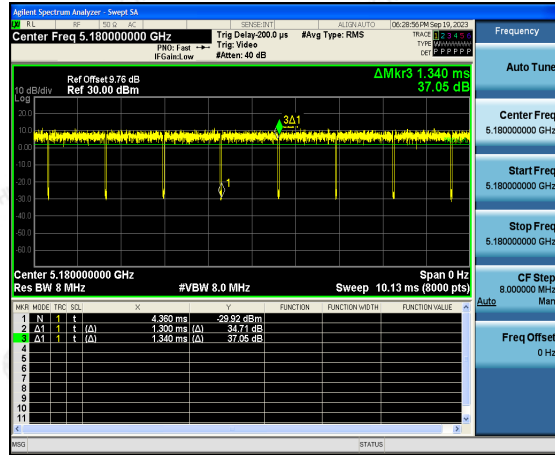

802.11ac(HT40)

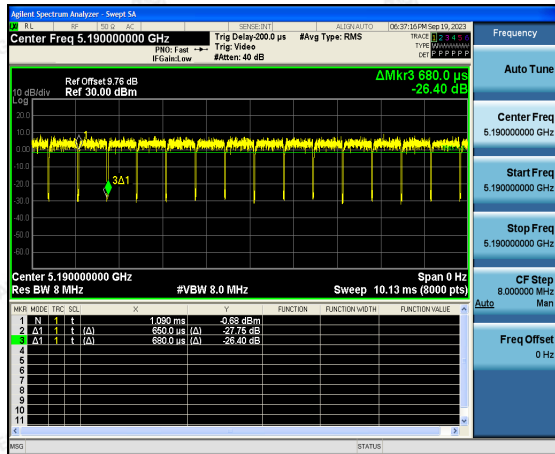

The results shown in this test report refer only to the sample(s) tested unless otherwise stated and the sample(s) are retained for 30 days only. The document is issued by HUAJ, this document cannot be reproduced except in full with our prior written permission. The more details and the authenticity of the report will be confirmed at <http://www.cer-mark.com>.

TEL : +86-755 2302 9901 FAX : +86-755 2302 9901 E-mail : service@cer-mark.com

Add: 1-2F., Building B2, Junfeng Zhongcheng Zhizao Innovation Park, Heping Community, Fuhai Street, Bao'an District, Shenzhen, Guangdong, China



4. Test Results and Measurement Data

4.1. Conducted Emission

4.1.1. Test Specification

Test Requirement:	FCC Part15 C Section 15.207														
Test Method:	ANSI C63.10:2013														
Frequency Range:	150 kHz to 30 MHz														
Receiver setup:	RBW=9 kHz, VBW=30 kHz, Sweep time=auto														
Limits:	<table border="1"> <thead> <tr> <th rowspan="2">Frequency range (MHz)</th> <th colspan="2">Limit (dBuV)</th> </tr> <tr> <th>Quasi-peak</th> <th>Average</th> </tr> </thead> <tbody> <tr> <td>0.15-0.5</td> <td>66 to 56*</td> <td>56 to 46*</td> </tr> <tr> <td>0.5-5</td> <td>56</td> <td>46</td> </tr> <tr> <td>5-30</td> <td>60</td> <td>50</td> </tr> </tbody> </table>	Frequency range (MHz)	Limit (dBuV)		Quasi-peak	Average	0.15-0.5	66 to 56*	56 to 46*	0.5-5	56	46	5-30	60	50
	Frequency range (MHz)		Limit (dBuV)												
		Quasi-peak	Average												
	0.15-0.5	66 to 56*	56 to 46*												
0.5-5	56	46													
5-30	60	50													
Test Setup:	<p>Reference Plane</p> <p>40cm</p> <p>E.U.T AC power 80cm LISN Filter AC power</p> <p>Test table/Insulation plane</p> <p>EMI Receiver</p> <p><i>Remark</i> E.U.T: Equipment Under Test LISN: Line Impedance Stabilization Network Test table height=0.8m</p>														
Test Mode:	Tx Mode														
Test Procedure:	<ol style="list-style-type: none"> 1. The E.U.T and simulators are connected to the main power through a line impedance stabilization network (L.I.S.N.). This provides a 50ohm/50uH coupling impedance for the measuring equipment. 2. The peripheral devices are also connected to the main power through a LISN that provides a 50ohm/50uH coupling impedance with 50ohm termination. (Please refer to the block diagram of the test setup and photographs). 3. Both sides of A.C. line are checked for maximum conducted interference. In order to find the maximum emission, the relative positions of equipment and all of the interface cables must be changed according to ANSI C63.10: 2013 on conducted measurement. 														
Test Result:	PASS														

The results shown in this test report refer only to the sample(s) tested unless otherwise stated and the sample(s) are retained for 30 days only. The document is issued by HUAKE, this document cannot be reproduced except in full with our prior written permission. The more details and the authenticity of the report will be confirmed at <http://www.cer-mark.com>.



4.1.2. Test Instruments

Conducted Emission Shielding Room Test Site (843)					
Equipment	Manufacturer	Model	Serial Number	Calibration Date	Calibration Due
Receiver	R&S	ESR-7	HKE-005	Feb. 17, 2023	Feb. 16, 2024
LISN	R&S	ENV216	HKE-002	Feb. 17, 2023	Feb. 16, 2024
Coax cable (9KHz-30MHz)	Times	381806-002	N/A	Feb. 17, 2023	Feb. 16, 2024
10dB Attenuator	Schwarzbeck	VTSD9561F	HKE-153	Feb. 17, 2023	Feb. 16, 2024
Conducted test software	Tonscend	TS+ Rev 2.5.0.0	HKE-081	N/A	N/A

Note: The calibration interval of the above test instruments is 12 months and the calibrations are traceable to international system unit (SI).



Test data

Remark: All the test modes completed for test. only the worst result Of was reported as below:
Conducted Emission on Line Terminal of the power line (150 kHz to 30MHz)

Test Specification: Line

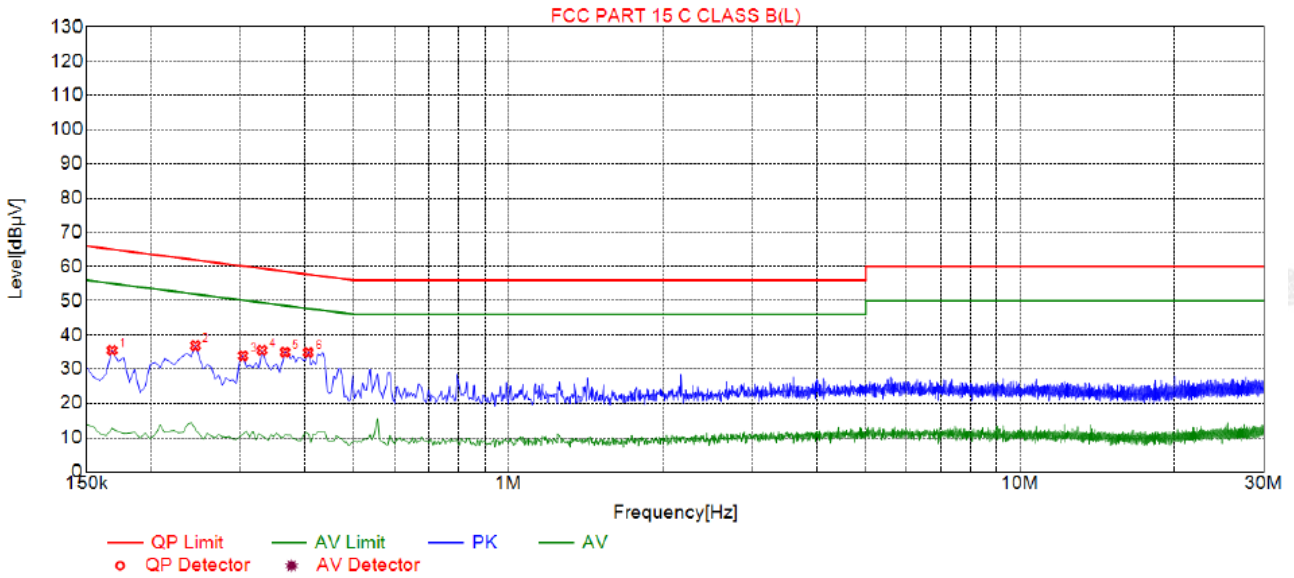

Suspected List

Table with 9 columns: NO., Freq. [MHz], Level [dBµV], Factor [dB], Limit [dBµV], Margin [dB], Reading [dBµV], Detector, Type. Contains 6 rows of suspected emission data.

Remark: Margin = Limit - Level
Correction factor = Cable lose + LISN insertion loss
Level=Test receiver reading + correction factor



Test Specification: Neutral

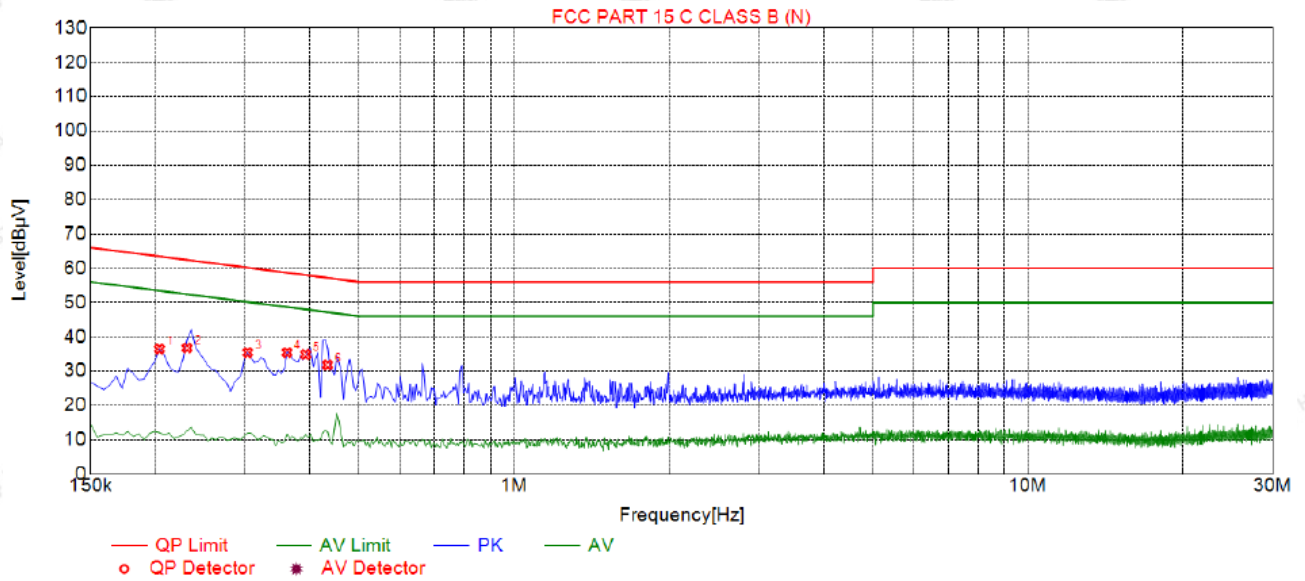

Suspected List

NO.	Freq. [MHz]	Level [dBµV]	Factor [dB]	Limit [dBµV]	Margin [dB]	Reading [dBµV]	Detector	Type
1	0.2040	36.46	20.04	63.45	26.99	16.42	PK	N
2	0.2310	36.74	20.03	62.41	25.67	16.71	PK	N
3	0.3030	35.42	20.04	60.16	24.74	15.38	PK	N
4	0.3615	35.44	20.04	58.69	23.25	15.40	PK	N
5	0.3930	34.88	20.04	58.00	23.12	14.84	PK	N
6	0.4335	31.81	20.05	57.19	25.38	11.76	PK	N

Remark: Margin = Limit - Level
 Correction factor = Cable lose + LISN insertion loss
 Level=Test receiver reading + correction factor

4.2. Maximum Conducted Output Power

4.2.1. Test Specification

Test Requirement:	FCC Part15 E Section 15.407(a)	
Test Method:	KDB789033 D02 General UNII Test Procedures New Rules v02.r01 Section E	
Limit:	Frequency Band (MHz)	Limit
	5150-5250	250mW for client devices
Test Setup:	<p>The diagram illustrates the test setup. On the left is a green box labeled 'Power meter'. A cable connects it to a small white box labeled 'Attenuator'. Another cable connects the attenuator to a yellow box labeled 'EUT' (Equipment Under Test).</p>	
Test Mode:	Transmitting mode with modulation	
Test Procedure:	<ol style="list-style-type: none"> 1. The testing follows the Measurement Procedure of KDB789033 D02 General UNII Test Procedures New Rules v02r01 Section E, 3, a. 2. The RF output of EUT was connected to the power meter by RF cable and attenuator. The path loss was compensated to the results for each measurement. 3. Set to the maximum power setting and enable the EUT transmit continuously. 4. Measure the conducted output power and record the results in the test report. 	
Test Result:	PASS	
Remark:	Conducted output power= measurement power +10log(1/x) X is duty cycle=1, so 10log(1/1)=0 Conducted output power= measurement power	



4.2.2. Test Instruments

RF Test Room					
Equipment	Manufacturer	Model	Serial Number	Calibration Date	Calibration Due
Spectrum analyzer	Agilent	N9020A	HKE-048	Feb. 17, 2023	Feb. 16, 2024
Power meter	Agilent	E4419B	HKE-085	Feb. 17, 2023	Feb. 16, 2024
Power Sensor	Agilent	E9300A	HKE-086	Feb. 17, 2023	Feb. 16, 2024
RF cable	Times	1-40G	HKE-034	Feb. 17, 2023	Feb. 16, 2024
RF automatic control unit	Tonscend	JS0806-2	HKE-060	Feb. 17, 2023	Feb. 16, 2024

Note: The calibration interval of the above test instruments is 12 months and the calibrations are traceable to international system unit (SI).



Test Data

Configuration Band I (5150 - 5250 MHz)				
Mode	Test channel	Maximum Conducted Output Power (dBm)	FCC Limit (dBm)	Result
11a	CH36	9.19	24	PASS
11a	CH40	8.93	24	PASS
11a	CH48	9.78	24	PASS
11n(HT20)	CH36	9.40	24	PASS
11n(HT20)	CH40	9.32	24	PASS
11n(HT20)	CH48	9.67	24	PASS
11n(HT40)	CH38	9.15	24	PASS
11n(HT40)	CH46	9.37	24	PASS
11ac(HT20)	CH36	9.38	24	PASS
11ac(HT20)	CH40	9.68	24	PASS
11ac(HT20)	CH48	9.69	24	PASS
11ac(HT40)	CH38	9.64	24	PASS
11ac(HT40)	CH46	9.07	24	PASS

Note: 1.The test results including the cable lose.

4.3. 6db Emission Bandwidth

4.3.1. Test Specification

Test Requirement:	FCC CFR47 Part 15 Section 15.407(e)
Test Method:	KDB789033 D02 General UNII Test Procedures New Rules v02r01 Section C
Limit:	>500kHz
Test Setup:	 <p style="text-align: center;">Spectrum Analyzer EUT</p>
Test Mode:	Transmitting mode with modulation
Test Procedure:	<ol style="list-style-type: none"> 1. KDB789033 D02 General UNII Test Procedures New Rules v02r01 Section C. 2. Set to the maximum power setting and enable the EUT transmit continuously. 3. Make the measurement with the spectrum analyzer's resolution bandwidth (RBW) = 100 kHz. Set the Video bandwidth (VBW) = 300 kHz. In order to make an accurate measurement. The 6dB bandwidth must be greater than 500 kHz. 4. Measure and record the results in the test report.
Test Result:	N/A

4.3.2. Test Instruments

RF Test Room					
Equipment	Manufacturer	Model	Serial Number	Calibration Date	Calibration Due
Spectrum analyzer	Agilent	N9020A	HKE-048	Feb. 17, 2023	Feb. 16, 2024
RF cable	Times	1-40G	HKE-034	Feb. 17, 2023	Feb. 16, 2024
RF automatic control unit	Tonscend	JS0806-2	HKE-060	Feb. 17, 2023	Feb. 16, 2024

Note: The calibration interval of the above test instruments is 12 months and the calibrations are traceable to international system unit (SI).

4.3.3 Test data

N/A

4.4. 26db Bandwidth and 99% Occupied Bandwidth

4.4.1. Test Specification

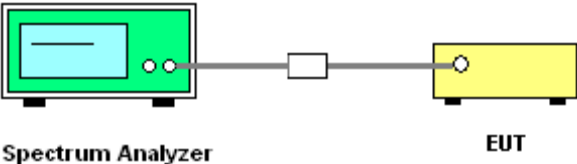
Test Requirement:	47 CFR Part 15C Section 15.407
Test Method:	KDB789033 D02 General UNII Test Procedures New Rules v02r01 Section C
Limit:	No restriction limits
Test Setup:	 <p style="text-align: center;">Spectrum Analyzer EUT</p>
Test Mode:	Transmitting mode with modulation
Test Procedure:	<ol style="list-style-type: none"> 1. KDB789033 D02 General UNII Test Procedures New Rules v02r01 Section C. 2. Set to the maximum power setting and enable the EUT transmit continuously. 3. Make the measurement with the spectrum analyzer's resolution bandwidth $RBW = 1\% EBW$, $VBW \geq 3RBW$, In order to make an accurate measurement. 4. Measure and record the results in the test report.
Test Result:	PASS

4.4.2. Test Instruments

RF Test Room					
Equipment	Manufacturer	Model	Serial Number	Calibration Date	Calibration Due
Spectrum analyzer	Agilent	N9020A	HKE-048	Feb. 17, 2023	Feb. 16, 2024
RF cable	Times	1-40G	HKE-034	Feb. 17, 2023	Feb. 16, 2024
RF automatic control unit	Tonscend	JS0806-2	HKE-060	Feb. 17, 2023	Feb. 16, 2024

Note: The calibration interval of the above test instruments is 12 months and the calibrations are traceable to international system unit (SI).



Test data

Band I

Mode	Test channel	Frequency (MHz)	26 dB Bandwidth (MHz)	Verdict
11a	CH36	5180	19.72	PASS
11a	CH40	5200	19.68	PASS
11a	CH48	5240	19.56	PASS
11n(HT20)	CH36	5180	21.24	PASS
11n(HT20)	CH40	5200	19.92	PASS
11n(HT20)	CH48	5240	19.96	PASS
11n(HT40)	CH38	5190	44.40	PASS
11n(HT40)	CH46	5230	45.52	PASS
11ac(HT20)	CH36	5180	20.00	PASS
11ac(HT20)	CH40	5200	19.92	PASS
11ac(HT20)	CH48	5240	19.84	PASS
11ac(HT40)	CH38	5190	46.96	PASS
11ac(HT40)	CH46	5230	42.00	PASS

Test plots as follows:



Band I (5150 – 5250 MHz)

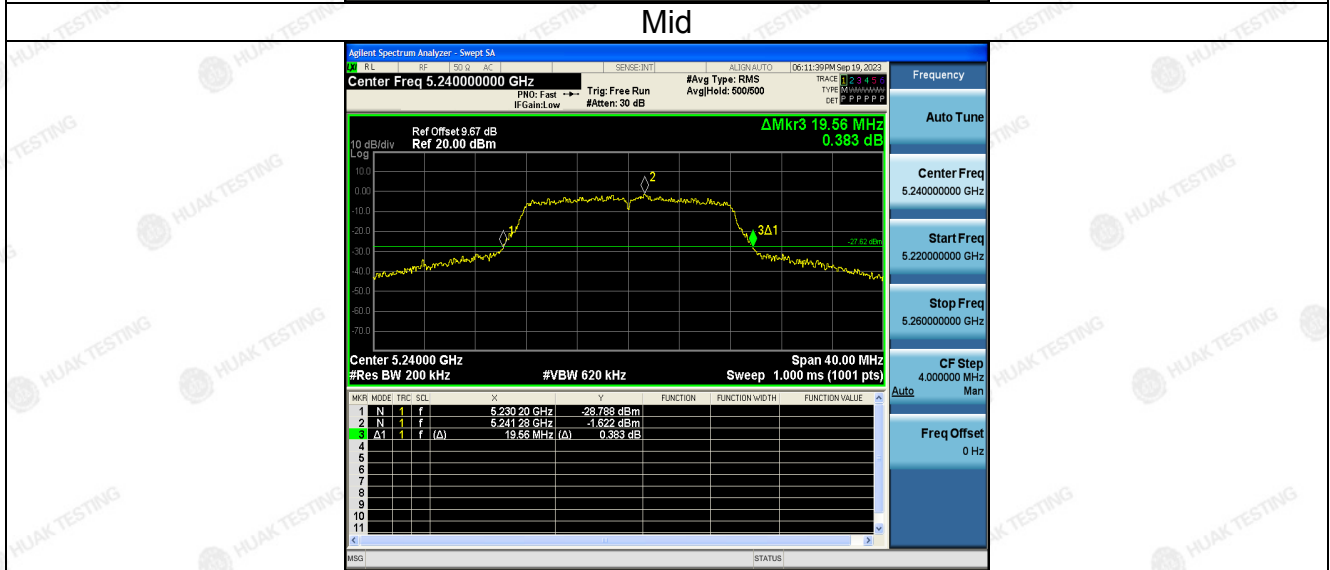
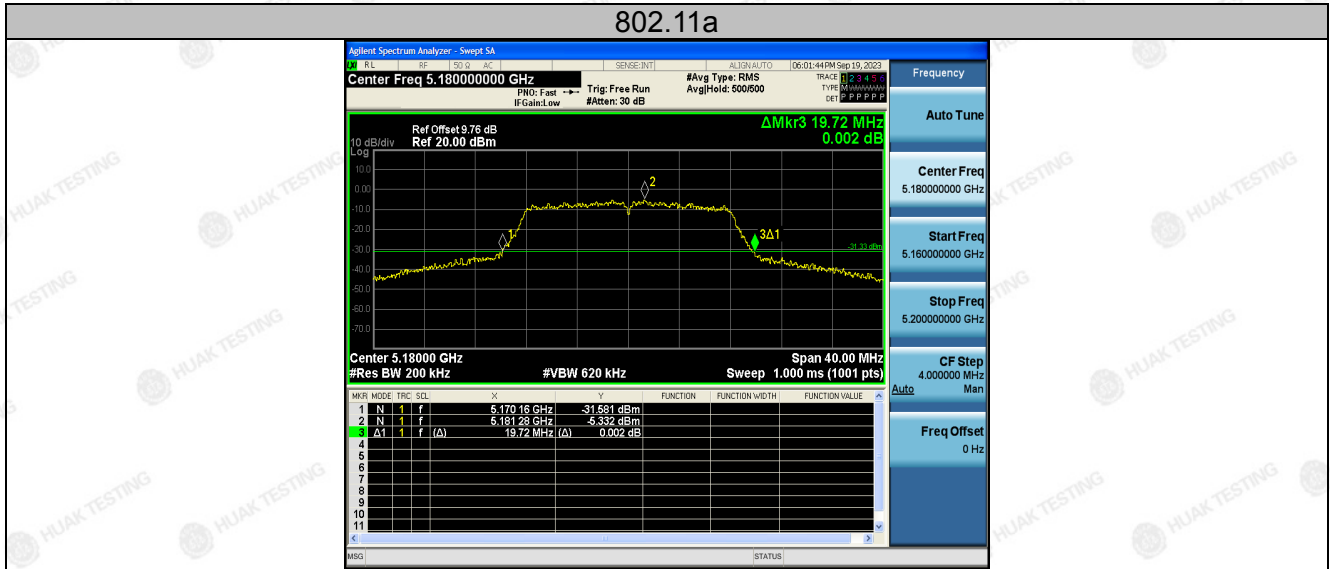

The results shown in this test report refer only to the sample(s) tested unless otherwise stated and the sample(s) are retained for 30 days only. The document is issued by HUAKE, this document cannot be reproduced except in full with our prior written permission. The more details and the authenticity of the report will be confirmed at <http://www.cer-mark.com>.

TEL : +86-755 2302 9901 FAX : +86-755 2302 9901 E-mail : service@cer-mark.com

Add: 1-2F., Building B2, Junfeng Zhongcheng Zhizao Innovation Park, Heping Community, Fuhai Street, Bao'an District, Shenzhen, Guangdong, China

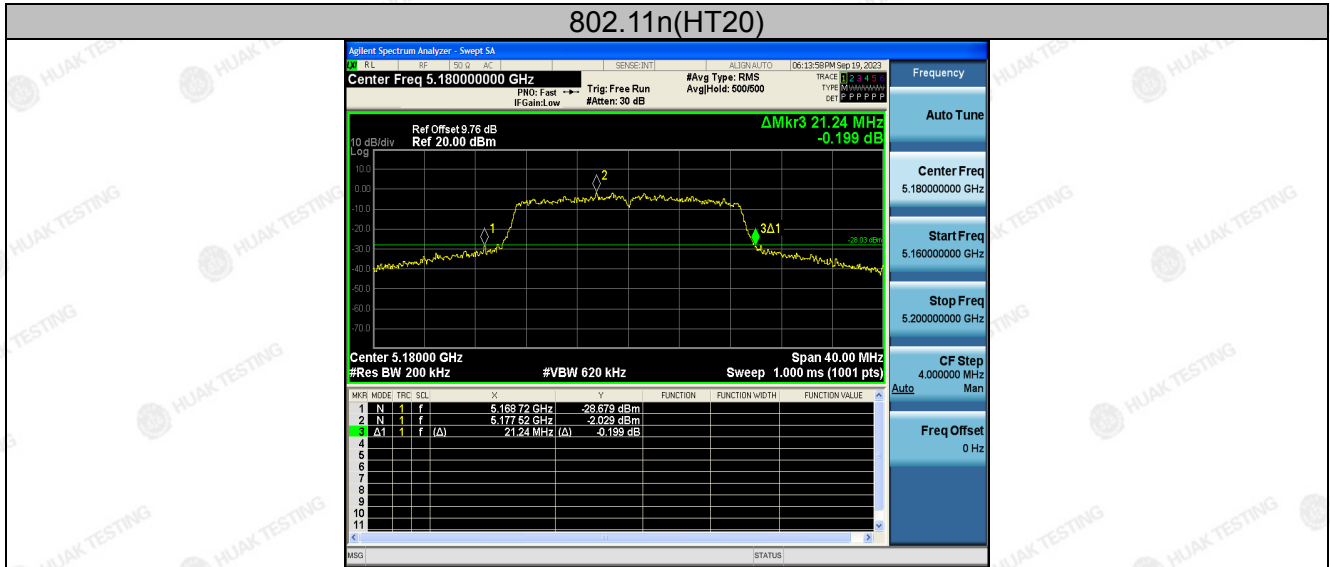

Low



Mid



High

The results shown in this test report refer only to the sample(s) tested unless otherwise stated and the sample(s) are retained for 30 days only. The document is issued by HUAJ, this document cannot be reproduced except in full with our prior written permission. The more details and the authenticity of the report will be confirmed at <http://www.cer-mark.com>.

TEL : +86-755 2302 9901 FAX : +86-755 2302 9901 E-mail : service@cer-mark.com

Add: 1-2F., Building B2, Junfeng Zhongcheng Zhizao Innovation Park, Heping Community, Fuhai Street, Bao'an District, Shenzhen, Guangdong, China

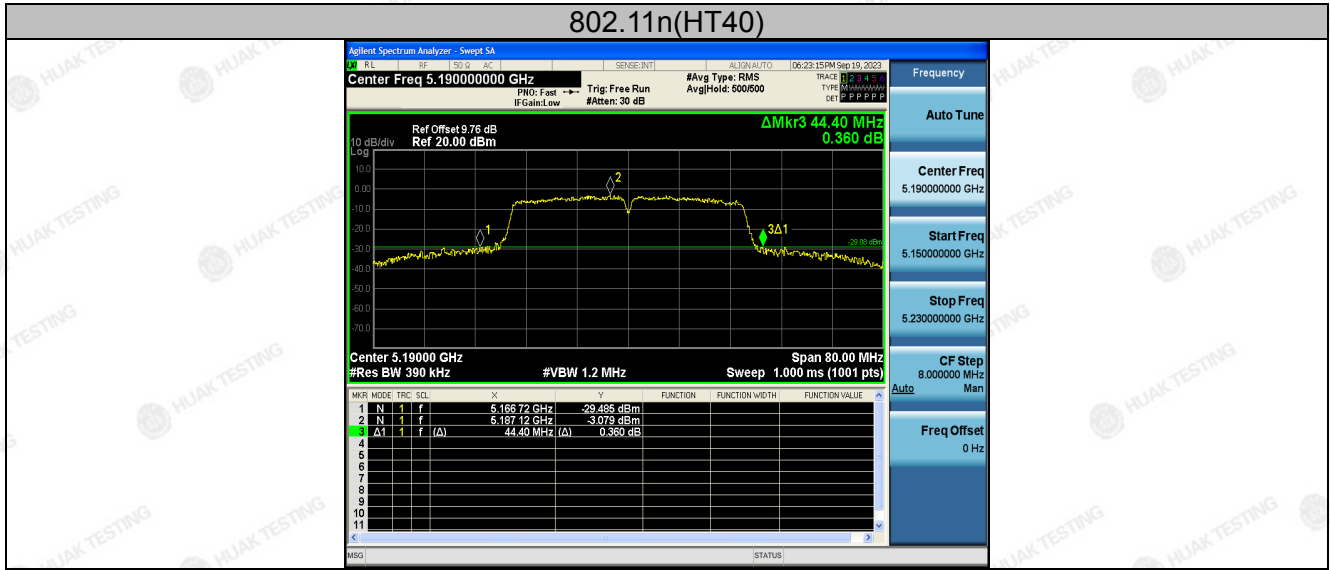

Low

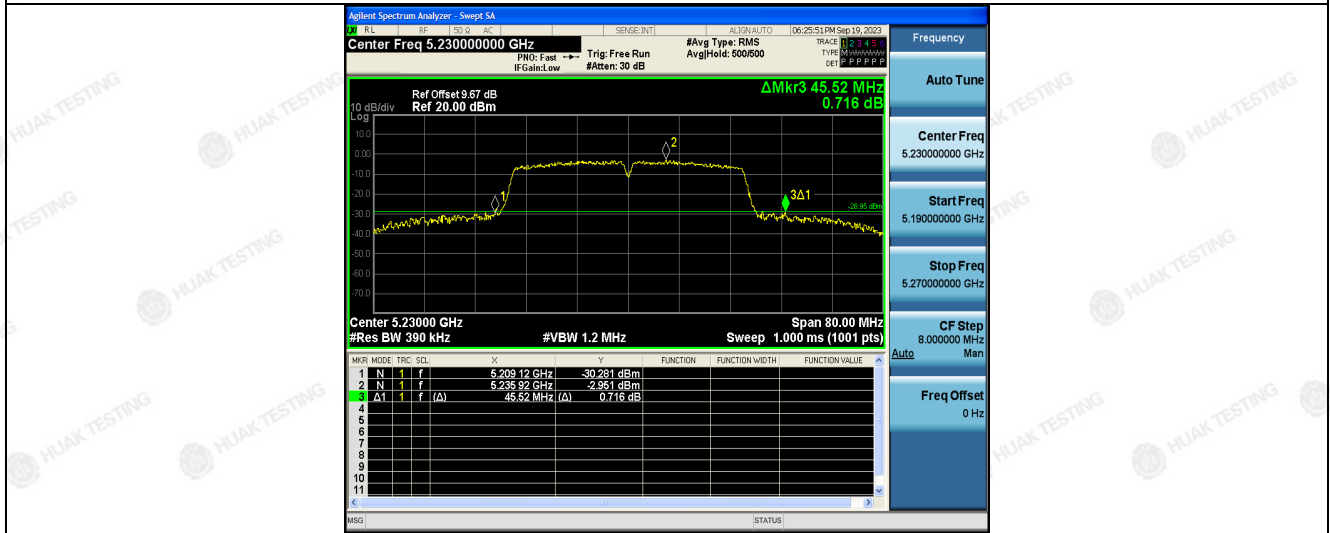

High

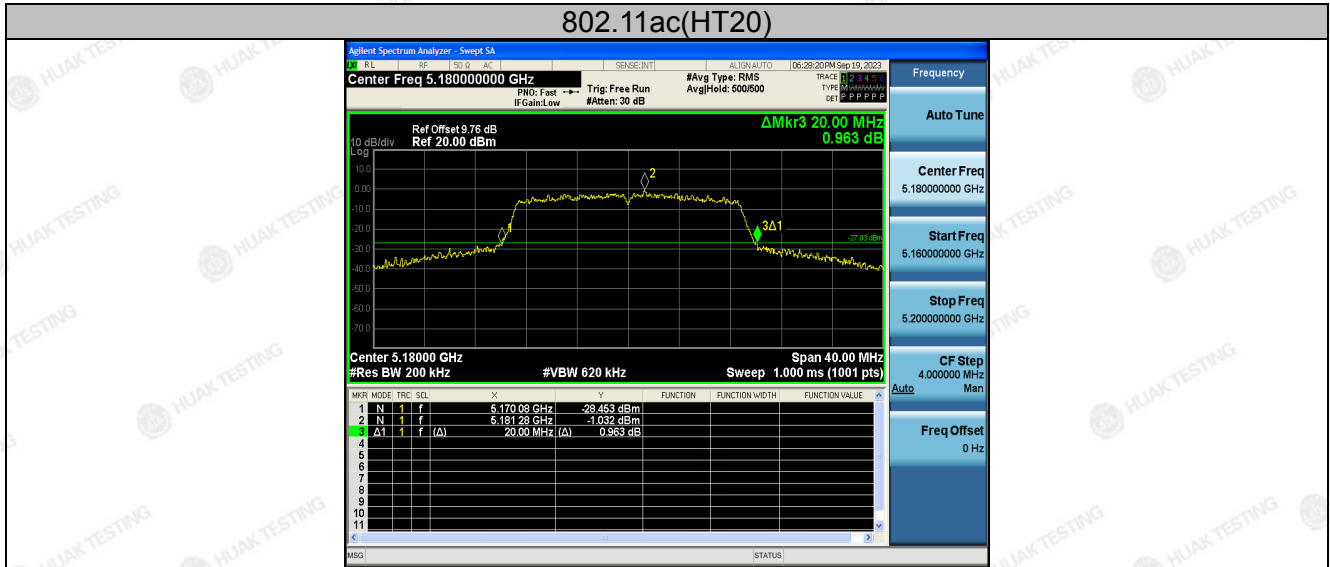

Low



Mid



High

The results shown in this test report refer only to the sample(s) tested unless otherwise stated and the sample(s) are retained for 30 days only. The document is issued by HUAJ, this document cannot be reproduced except in full with our prior written permission. The more details and the authenticity of the report will be confirmed at <http://www.cer-mark.com>.

TEL : +86-755 2302 9901 FAX : +86-755 2302 9901 E-mail : service@cer-mark.com

Add: 1-2F., Building B2, Junfeng Zhongcheng Zhizao Innovation Park, Heping Community, Fuhai Street, Bao'an District, Shenzhen, Guangdong, China

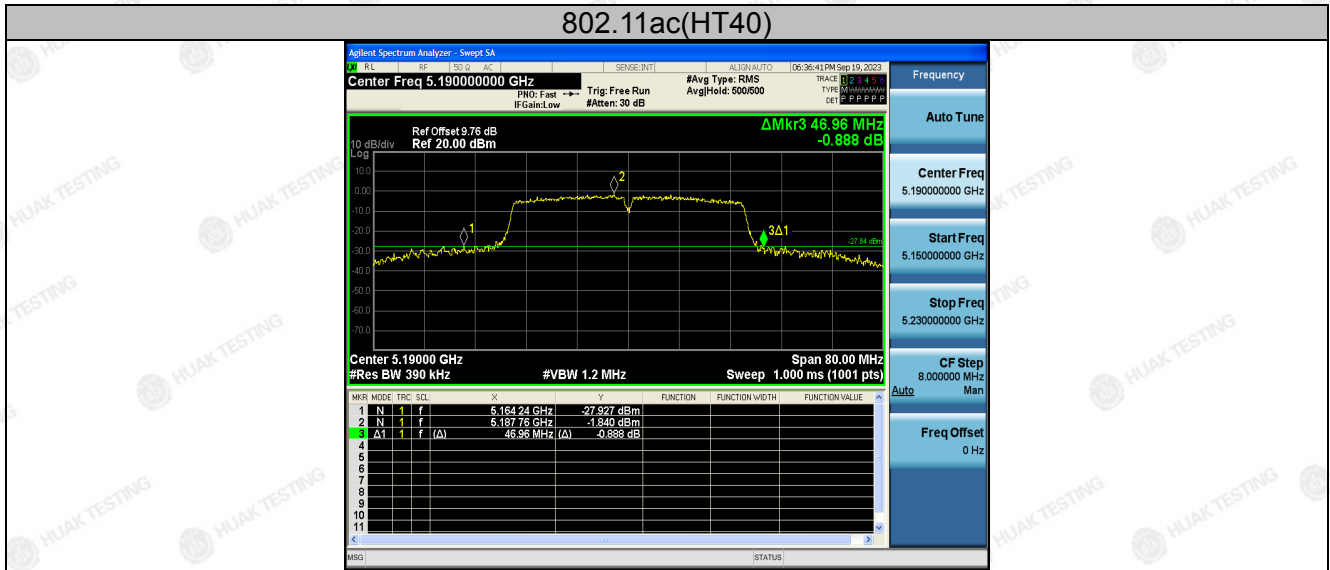

Low



High

The results shown in this test report refer only to the sample(s) tested unless otherwise stated and the sample(s) are retained for 30 days only. The document is issued by HUAJ, this document cannot be reproduced except in full with our prior written permission. The more details and the authenticity of the report will be confirmed at <http://www.cer-mark.com>.

TEL : +86-755 2302 9901 FAX : +86-755 2302 9901 E-mail : service@cer-mark.com

Add: 1-2F., Building B2, Junfeng Zhongcheng Zhizao Innovation Park, Heping Community, Fuhai Street, Bao'an District, Shenzhen, Guangdong, China

4.5. Power Spectral Density

4.5.1. Test Specification

Test Requirement:	FCC Part15 E Section 15.407 (a)
Test Method:	KDB789033 D02 General UNII Test Procedures New Rules v02r01 Section F
Limit:	≤11.00dBm/MHz for Band I 5150MHz-5250MHz
Test Setup:	 <p style="text-align: center;"> Spectrum Analyzer EUT </p>
Test Mode:	Transmitting mode with modulation
Test Procedure:	<ol style="list-style-type: none"> 1. Set the spectrum analyzer or EMI receiver span to view the entire emission bandwidth. 2. Set RBW = 1 MHz, VBW ≥ 3*RBW, Sweep time = Auto, Detector = RMS. 3. Allow the sweeps to continue until the trace stabilizes. 4. Use the peak marker function to determine the maximum amplitude level. 5. The E.I.R.P spectral density used radiated test method. At a test site that has been validated using the procedures of ANSI C63.4 or the latest CISPR 16-1-4 for measurements above 1 GHz, so as to simulate a near free-space environment.
Test Result:	PASS

4.5.2. Test Instruments

RF Test Room					
Equipment	Manufacturer	Model	Serial Number	Calibration Date	Calibration Due
Spectrum analyzer	Agilent	N9020A	HKE-048	Feb. 17, 2023	Feb. 16, 2024
RF cable	Times	1-40G	HKE-034	Feb. 17, 2023	Feb. 16, 2024
RF automatic control unit	Tonscend	JS0806-2	HKE-060	Feb. 17, 2023	Feb. 16, 2024

Note: The calibration interval of the above test instruments is 12 months and the calibrations are traceable to international system unit (SI).



4.5.3. Test data

Configuration Band I (5150 - 5250 MHz)				
Mode	Test channel	Level [dBm/MHz]	Limit (dBm/MHz)	Result
11a	CH36	3.77	11	PASS
11a	CH40	6.84	11	PASS
11a	CH48	6.88	11	PASS
11n(HT20)	CH36	4.58	11	PASS
11n(HT20)	CH40	5.41	11	PASS
11n(HT20)	CH48	6.45	11	PASS
11n(HT40)	CH38	3.29	11	PASS
11n(HT40)	CH46	3.90	11	PASS
11ac(HT20)	CH36	3.28	11	PASS
11ac(HT20)	CH40	6.50	11	PASS
11ac(HT20)	CH48	5.95	11	PASS
11ac(HT40)	CH38	3.37	11	PASS
11ac(HT40)	CH46	3.41	11	PASS

Note: Instrument attenuation and cable loss See test diagram



Band I (5150 – 5250 MHz)

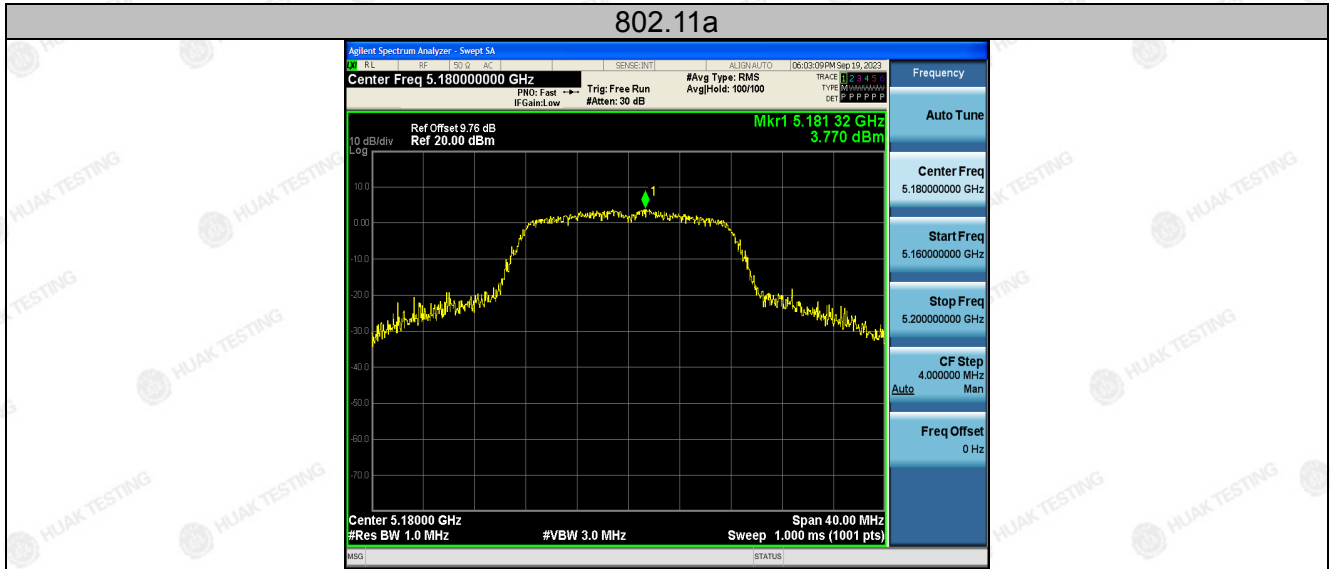

Low



Mid

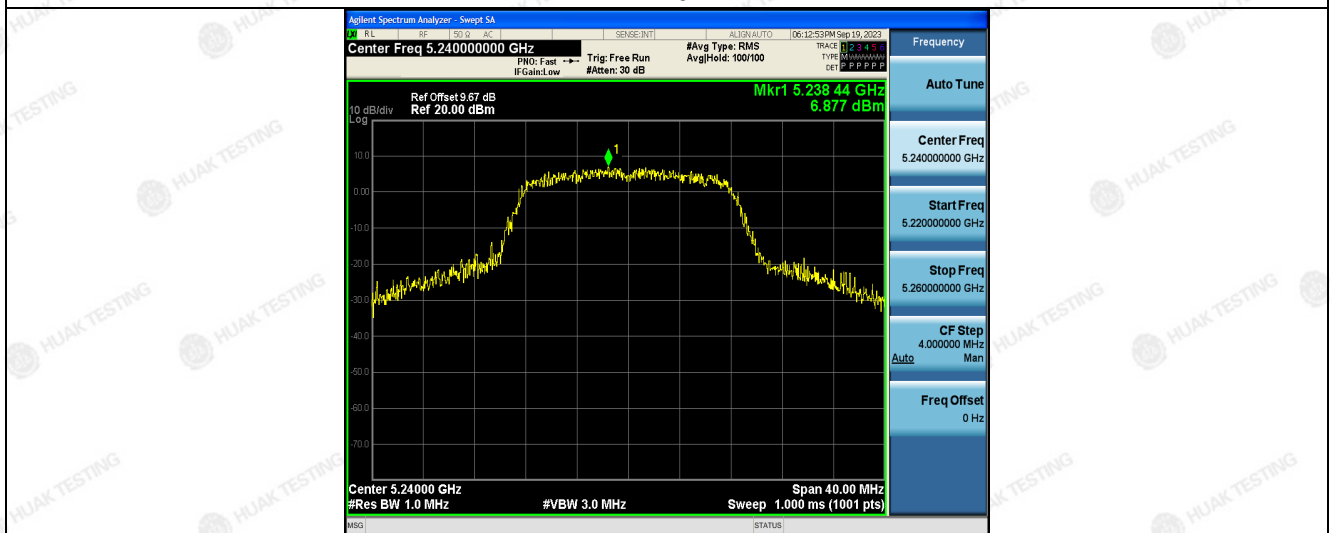

High

The results shown in this test report refer only to the sample(s) tested unless otherwise stated and the sample(s) are retained for 30 days only. The document is issued by HUAKE, this document cannot be reproduced except in full with our prior written permission. The more details and the authenticity of the report will be confirmed at <http://www.cer-mark.com>.

TEL : +86-755 2302 9901 FAX : +86-755 2302 9901 E-mail : service@cer-mark.com

Add: 1-2F., Building B2, Junfeng Zhongcheng Zhizao Innovation Park, Heping Community, Fuhai Street, Bao'an District, Shenzhen, Guangdong, China



802.11n(HT20)

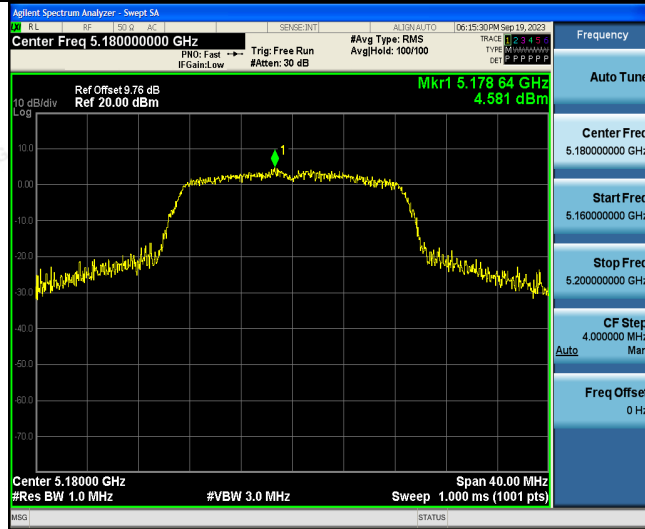

Low

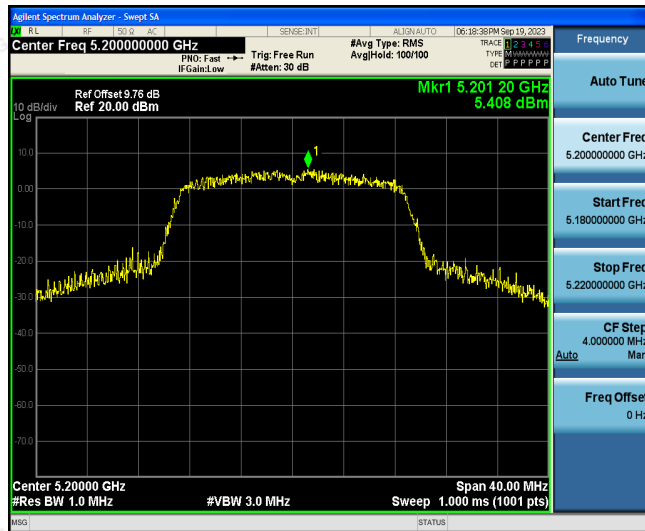

Mid

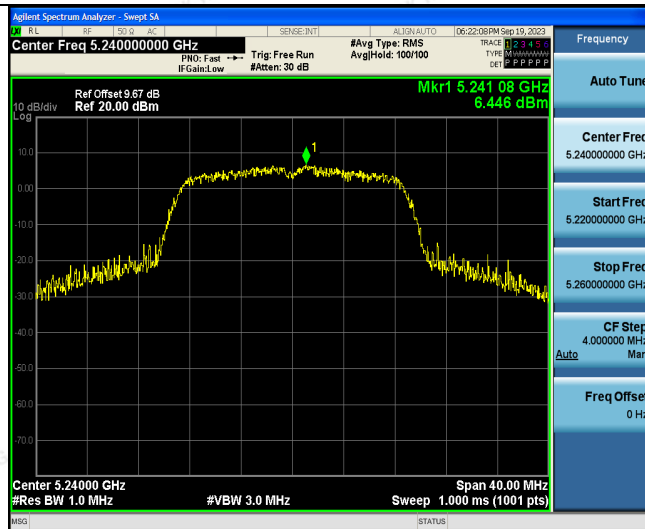

High

The results shown in this test report refer only to the sample(s) tested unless otherwise stated and the sample(s) are retained for 30 days only. The document is issued by HUAKE, this document cannot be reproduced except in full with our prior written permission. The more details and the authenticity of the report will be confirmed at <http://www.cer-mark.com>.

TEL : +86-755 2302 9901 FAX : +86-755 2302 9901 E-mail : service@cer-mark.com

Add: 1-2F., Building B2, Junfeng Zhongcheng Zhizao Innovation Park, Heping Community, Fuhai Street, Bao'an District, Shenzhen, Guangdong, China



802.11n(HT40)

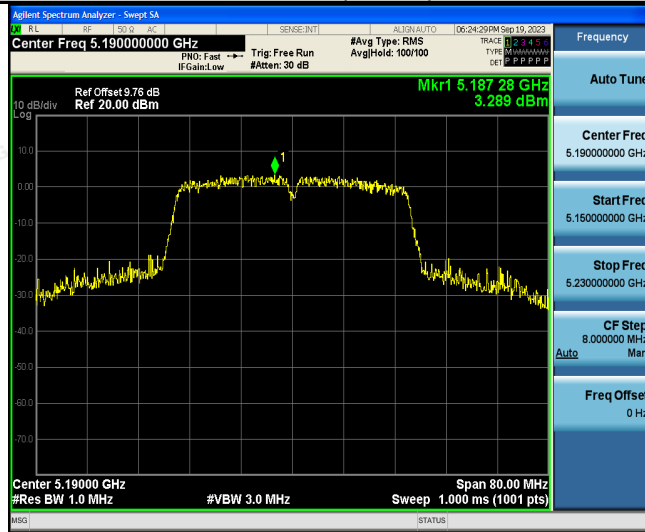

Low

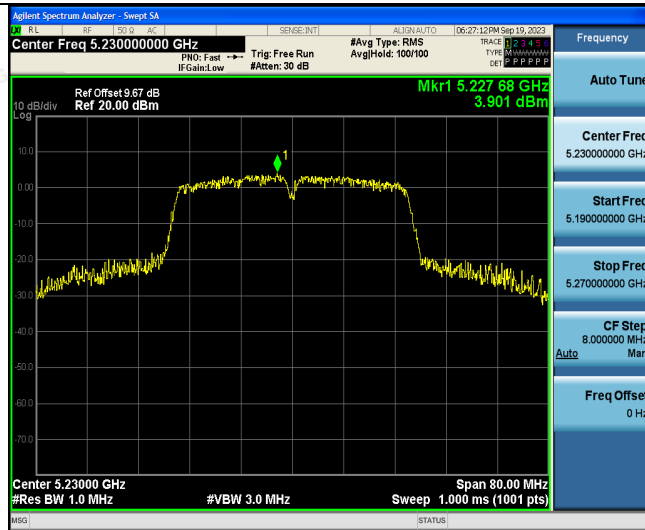

High

The results shown in this test report refer only to the sample(s) tested unless otherwise stated and the sample(s) are retained for 30 days only. The document is issued by HUAKE, this document cannot be reproduced except in full with our prior written permission. The more details and the authenticity of the report will be confirmed at <http://www.cer-mark.com>.

TEL : +86-755 2302 9901 FAX : +86-755 2302 9901 E-mail : service@cer-mark.com

Add: 1-2F., Building B2, Junfeng Zhongcheng Zhizao Innovation Park, Heping Community, Fuhai Street, Bao'an District, Shenzhen, Guangdong, China



802.11ac(HT20)

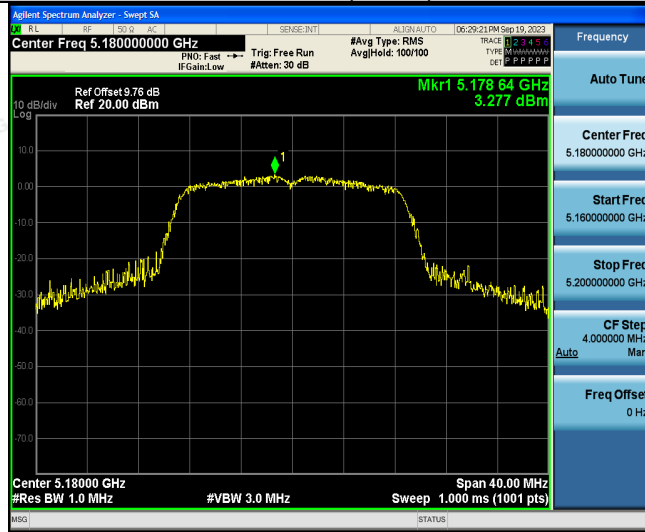

Low

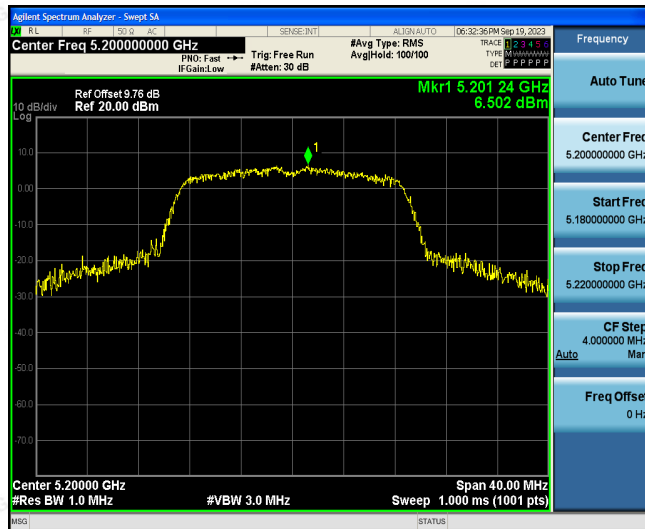

Mid

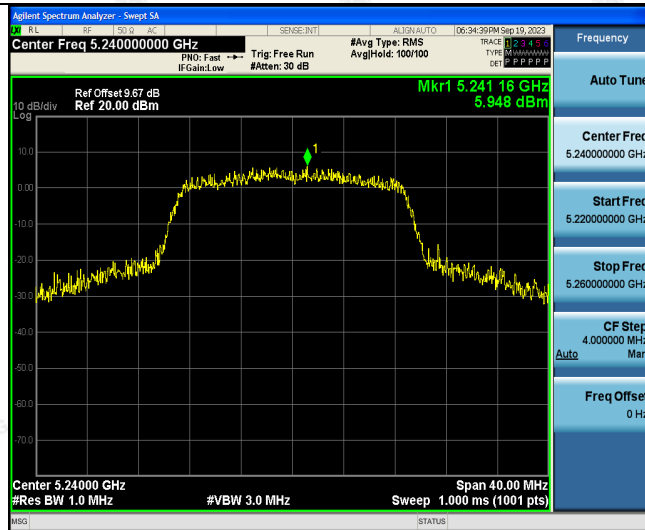

High

The results shown in this test report refer only to the sample(s) tested unless otherwise stated and the sample(s) are retained for 30 days only. The document is issued by HUAJ, this document cannot be reproduced except in full with our prior written permission. The more details and the authenticity of the report will be confirmed at <http://www.cer-mark.com>.

TEL : +86-755 2302 9901 FAX : +86-755 2302 9901 E-mail : service@cer-mark.com

Add: 1-2F., Building B2, Junfeng Zhongcheng Zhizao Innovation Park, Heping Community, Fuhai Street, Bao'an District, Shenzhen, Guangdong, China



802.11ac(HT40)

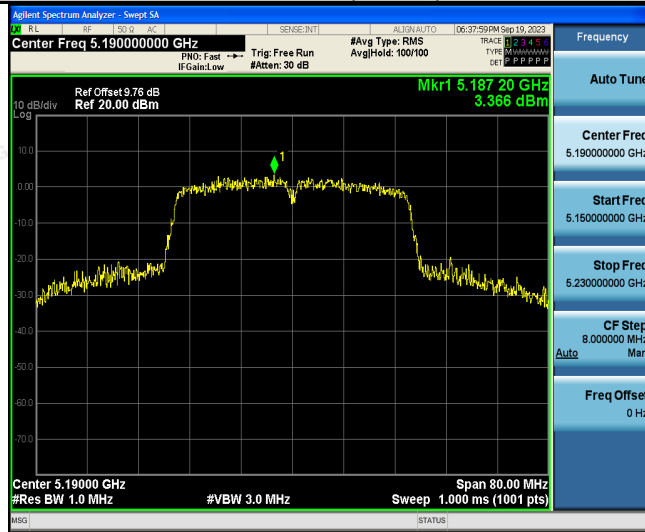

Low



High

The results shown in this test report refer only to the sample(s) tested unless otherwise stated and the sample(s) are retained for 30 days only. The document is issued by HUAKE, this document cannot be reproduced except in full with our prior written permission. The more details and the authenticity of the report will be confirmed at <http://www.cer-mark.com>.

TEL : +86-755 2302 9901 FAX : +86-755 2302 9901 E-mail : service@cer-mark.com

Add: 1-2F., Building B2, Junfeng Zhongcheng Zhizao Innovation Park, Heping Community, Fuhai Street, Bao'an District, Shenzhen, Guangdong, China

4.6. Band Edge

4.6.1. Test Specification

Test Requirement:	FCC CFR47 Part 15E Section 15.407
Test Method:	ANSI C63.10 2013
Limit:	<p>For band I&II&III: $E[\text{dB}\mu\text{V}/\text{m}] = \text{EIRP}[\text{dBm}] + 95.2 = 68.2 \text{ dB}\mu\text{V}/\text{m}$, for $\text{EIRP}(\text{dBm}) = -27\text{dBm}$</p> <p>For transmitters operating in the 5.725-5.85 GHz band:</p> <p>All emissions shall be limited to a level of $-27 \text{ dBm}/\text{MHz}$ at 75 MHz or more above or below the band edge increasing linearly to $10 \text{ dBm}/\text{MHz}$ at 25 MHz above or below the band edge, and from 25 MHz above or below the band edge increasing linearly to a level of $15.6 \text{ dBm}/\text{MHz}$ at 5 MHz above or below the band edge, and from 5 MHz above or below the band edge increasing linearly to a level of $27 \text{ dBm}/\text{MHz}$ at the band edge.</p> <p>For band IV(5715-5725MHz&5850-5860MHz): $E[\text{dB}\mu\text{V}/\text{m}] = \text{EIRP}[\text{dBm}] + 95.2 = 78.2 \text{ dB}\mu\text{V}/\text{m}$, for $\text{EIRP}(\text{dBm}) = -27\text{dBm}$;</p> <p>For band IV(other un-restricted band): $E[\text{dB}\mu\text{V}/\text{m}] = \text{EIRP}[\text{dBm}] + 95.2 = 68.2 \text{ dB}\mu\text{V}/\text{m}$, for $\text{EIRP}(\text{dBm}) = -27\text{dBm}$</p>
Test Setup:	<p>The diagram illustrates the test setup. An EUT (Equipment Under Test) is placed on a rotating table that is 1.5 meters high. The table is positioned 3 meters away from an antenna tower. The antenna tower is 1-4 meters high. The antenna is connected to a receiver and an amplifier. The ground plane is indicated at the base of the setup.</p>
Test Mode:	Transmitting mode with modulation
Test Procedure:	<ol style="list-style-type: none"> 1. The EUT was placed on the top of a rotating table 1.5 meters above the ground at a 3 meter camber. The table was rotated 360 degrees to determine the position of the highest radiation. 2. The EUT was set 3 meters away from the interference-receiving antenna, which was mounted on the top of a variable-height antenna tower. 3. The antenna height is varied from one meter to four meters above the ground to determine the maximum value of the field strength. Both horizontal and vertical polarizations of the antenna are set to make the measurement.



Test Procedure:	<p>4. For each suspected emission, the EUT was arranged to its worst case and then the antenna was tuned to heights from 1 meter to 4 meters and the rota table was turned from 0 degrees to 360 degrees to find the maximum reading.</p> <p>5. The test-receiver system was set to Peak Detect Function and Specified Bandwidth with Maximum Hold Mode.</p> <p>6. If the emission level of the EUT in peak mode was 10dB lower than the limit specified, then testing could be stopped and the peak values of the EUT would be reported. Otherwise the emissions that did not have 10dB margin would be re-tested one by one using peak, quasi peak or average method as specified and then reported in a data sheet.</p>
Test Result:	PASS



4.6.2. Test Instruments

Radiated Emission Test Site (966)					
Name of Equipment	Manufacturer	Model	Serial Number	Calibration Date	Calibration Due
Receiver	R&S	ESRP3	HKE-005	Feb. 17, 2023	Feb. 16, 2024
Spectrum analyzer	Agilent	N9020A	HKE-048	Feb. 17, 2023	Feb. 16, 2024
Preamplifier	EMCI	EMC051845S E	HKE-015	Feb. 17, 2023	Feb. 16, 2024
Preamplifier	Agilent	83051A	HKE-016	Feb. 17, 2023	Feb. 16, 2024
Loop antenna	Schwarzbeck	FMZB 1519 B	HKE-014	Feb. 17, 2023	Feb. 16, 2024
Broadband antenna	Schwarzbeck	VULB 9163	HKE-012	Feb. 17, 2023	Feb. 16, 2024
Horn antenna	Schwarzbeck	9120D	HKE-013	Feb. 17, 2023	Feb. 16, 2024
Antenna Mast	Keleto	CC-A-4M	N/A	N/A	N/A
Position controller	Taiwan MF	MF7802	HKE-011	Feb. 17, 2023	Feb. 16, 2024
Radiated test software	Tonscend	TS+ Rev 2.5.0.0	HKE-082	N/A	N/A
RF cable (9KHz-1GHz)	Times	381806-001	N/A	N/A	N/A
Hf antenna	Schwarzbeck	LB-180400-K F	HKE-031	Feb. 17, 2023	Feb. 16, 2024
RF cable	Tonscend	1-18G	HKE-099	Feb. 17, 2023	Feb. 16, 2024
RF cable	Times	1-40G	HKE-034	Feb. 17, 2023	Feb. 16, 2024

Note: The calibration interval of the above test instruments is 12 months and the calibrations are traceable to international system unit (SI).



4.6.3. Test Data

Radiated Band Edge Test:

Operation Mode: 802.11a Mode with 5.2G TX CH Low

Horizontal

Frequency	Meter Reading	Factor	Emission Level	Limits	Margin	Detector Type
(MHz)	(dBμV)	(dB)	(dBμV/m)	(dBμV/m)	(dB)	
5150	55.32	-2.49	52.83	74	-21.17	peak
5150	/	-2.49	/	54	/	AVG

Remark: Factor = Antenna Factor + Cable Loss – Pre-amplifier; Level = Reading + Factor; Margin = Level-Limit.

Vertical:

Frequency	Meter Reading	Factor	Emission Level	Limits	Margin	Detector Type
(MHz)	(dBμV)	(dB)	(dBμV/m)	(dBμV/m)	(dB)	
5150	54.05	-2.49	51.56	74	-22.44	peak
5150	/	-2.49	/	54	/	AVG

Remark: Factor = Antenna Factor + Cable Loss – Pre-amplifier; Level = Reading + Factor; Margin = Level-Limit.



Operation Mode: TX CH High with 5.2G

Horizontal

Frequency	Meter Reading	Factor	Emission Level	Limits	Margin	Detector Type
(MHz)	(dBμV)	(dB)	(dBμV/m)	(dBμV/m)	(dB)	
5350	53.61	-2.11	51.5	74	-22.5	peak
5350	/	-2.11	/	54	/	AVG

Remark: Factor = Antenna Factor + Cable Loss – Pre-amplifier; Level = Reading + Factor; Margin = Level-Limit.

Vertical:

Frequency	Meter Reading	Factor	Emission Level	Limits	Margin	Detector Type
(MHz)	(dBμV)	(dB)	(dBμV/m)	(dBμV/m)	(dB)	
5350	51.74	-2.11	49.63	74	-24.37	peak
5350	/	-2.11	/	54	/	AVG

Remark: Factor = Antenna Factor + Cable Loss – Pre-amplifier; Level = Reading + Factor; Margin = Level-Limit.



Operation Mode: 802.11n20 Mode with 5.2G TX CH Low

Horizontal

Frequency	Meter Reading	Factor	Emission Level	Limits	Margin	Detector Type
(MHz)	(dBμV)	(dB)	(dBμV/m)	(dBμV/m)	(dB)	
5150	54.26	-2.49	51.77	74	-22.23	peak
5150	/	-2.49	/	54	/	AVG

Remark: Factor = Antenna Factor + Cable Loss – Pre-amplifier; Level = Reading + Factor; Margin = Level-Limit.

Vertical:

Frequency	Meter Reading	Factor	Emission Level	Limits	Margin	Detector Type
(MHz)	(dBμV)	(dB)	(dBμV/m)	(dBμV/m)	(dB)	
5150	52.64	-2.49	50.15	74	-23.85	peak
5150	/	-2.49	/	54	/	AVG

Remark: Factor = Antenna Factor + Cable Loss – Pre-amplifier; Level = Reading + Factor; Margin = Level-Limit.



Operation Mode: TX CH High with 5.2G

Horizontal

Frequency	Meter Reading	Factor	Emission Level	Limits	Margin	Detector Type
(MHz)	(dBμV)	(dB)	(dBμV/m)	(dBμV/m)	(dB)	
5350	54.32	-2.11	52.21	74	-21.79	peak
5350	/	-2.11	/	54	/	AVG

Remark: Factor = Antenna Factor + Cable Loss – Pre-amplifier; Level = Reading + Factor; Margin = Level-Limit.

Vertical:

Frequency	Meter Reading	Factor	Emission Level	Limits	Margin	Detector Type
(MHz)	(dBμV)	(dB)	(dBμV/m)	(dBμV/m)	(dB)	
5350	51.79	-2.11	49.68	74	-24.32	peak
5350	/	-2.11	/	54	/	AVG

Remark: Factor = Antenna Factor + Cable Loss – Pre-amplifier; Level = Reading + Factor; Margin = Level-Limit.



Operation Mode: 802.11 n40 Mode with 5.2G TX CH Low

Horizontal

Frequency	Meter Reading	Factor	Emission Level	Limits	Margin	Detector Type
(MHz)	(dBμV)	(dB)	(dBμV/m)	(dBμV/m)	(dB)	
5150	55.22	-2.49	52.73	74	-21.27	peak
5150	/	-2.49	/	54	/	AVG

Remark: Factor = Antenna Factor + Cable Loss – Pre-amplifier; Level = Reading + Factor; Margin = Level-Limit.

Vertical:

Frequency	Meter Reading	Factor	Emission Level	Limits	Margin	Detector Type
(MHz)	(dBμV)	(dB)	(dBμV/m)	(dBμV/m)	(dB)	
5150	53.14	-2.49	50.65	74	-23.35	peak
5150	/	-2.49	/	54	/	AVG

Remark: Factor = Antenna Factor + Cable Loss – Pre-amplifier; Level = Reading + Factor; Margin = Level-Limit.



Operation Mode: TX CH High with 5.2G

Horizontal

Frequency	Meter Reading	Factor	Emission Level	Limits	Margin	Detector Type
(MHz)	(dBμV)	(dB)	(dBμV/m)	(dBμV/m)	(dB)	
5350	53.64	-2.11	51.53	74	-22.47	peak
5350	/	-2.11	/	54	/	AVG

Remark: Factor = Antenna Factor + Cable Loss – Pre-amplifier; Level = Reading + Factor; Margin = Level-Limit.

Vertical:

Frequency	Meter Reading	Factor	Emission Level	Limits	Margin	Detector Type
(MHz)	(dBμV)	(dB)	(dBμV/m)	(dBμV/m)	(dB)	
5350	52.43	-2.11	50.32	74	-23.68	peak
5350	/	-2.11	/	54	/	AVG

Remark: Factor = Antenna Factor + Cable Loss – Pre-amplifier; Level = Reading + Factor; Margin = Level-Limit.



Operation Mode: 802.11ac20 Mode with 5.2G TX CH Low

Horizontal

Frequency	Meter Reading	Factor	Emission Level	Limits	Margin	Detector Type
(MHz)	(dBμV)	(dB)	(dBμV/m)	(dBμV/m)	(dB)	
5150	54.28	-2.49	51.79	74	-22.21	peak
5150	/	-2.49	/	54	/	AVG

Remark: Factor = Antenna Factor + Cable Loss – Pre-amplifier; Level = Reading + Factor; Margin = Level-Limit.

Vertical:

Frequency	Meter Reading	Factor	Emission Level	Limits	Margin	Detector Type
(MHz)	(dBμV)	(dB)	(dBμV/m)	(dBμV/m)	(dB)	
5150	52.61	-2.49	50.12	74	-23.88	peak
5150	/	-2.49	/	54	/	AVG

Remark: Factor = Antenna Factor + Cable Loss – Pre-amplifier; Level = Reading + Factor; Margin = Level-Limit.



Operation Mode: TX CH High with 5.2G

Horizontal

Frequency	Meter Reading	Factor	Emission Level	Limits	Margin	Detector Type
(MHz)	(dBμV)	(dB)	(dBμV/m)	(dBμV/m)	(dB)	
5350	54.29	-2.11	52.18	74	-21.82	peak
5350	/	-2.11	/	54	/	AVG

Remark: Factor = Antenna Factor + Cable Loss – Pre-amplifier; Level = Reading + Factor; Margin = Level-Limit.

Vertical:

Frequency	Meter Reading	Factor	Emission Level	Limits	Margin	Detector Type
(MHz)	(dBμV)	(dB)	(dBμV/m)	(dBμV/m)	(dB)	
5350	51.68	-2.11	49.57	74	-24.43	peak
5350	/	-2.11	/	54	/	AVG

Remark: Factor = Antenna Factor + Cable Loss – Pre-amplifier; Level = Reading + Factor; Margin = Level-Limit.



Operation Mode: 802.11 ac40 Mode with 5.2G TX CH Low

Horizontal

Frequency	Meter Reading	Factor	Emission Level	Limits	Margin	Detector Type
(MHz)	(dBµV)	(dB)	(dBµV/m)	(dBµV/m)	(dB)	
5150	55.49	-2.49	53	74	-21	peak
5150	/	-2.49	/	54	/	AVG

Remark: Factor = Antenna Factor + Cable Loss – Pre-amplifier; Level = Reading + Factor; Margin = Level-Limit.

Vertical:

Frequency	Meter Reading	Factor	Emission Level	Limits	Margin	Detector Type
(MHz)	(dBµV)	(dB)	(dBµV/m)	(dBµV/m)	(dB)	
5150	53.18	-2.49	50.69	74	-23.31	peak
5150	/	-2.49	/	54	/	AVG

Remark: Factor = Antenna Factor + Cable Loss – Pre-amplifier; Level = Reading + Factor; Margin = Level-Limit.



Operation Mode: TX CH High with 5.2G

Horizontal

Frequency	Meter Reading	Factor	Emission Level	Limits	Margin	Detector Type
(MHz)	(dBμV)	(dB)	(dBμV/m)	(dBμV/m)	(dB)	
5350	53.87	-2.11	51.76	74	-22.24	peak
5350	/	-2.11	/	54	/	AVG

Remark: Factor = Antenna Factor + Cable Loss – Pre-amplifier; Level = Reading + Factor; Margin = Level-Limit.

Vertical:

Frequency	Meter Reading	Factor	Emission Level	Limits	Margin	Detector Type
(MHz)	(dBμV)	(dB)	(dBμV/m)	(dBμV/m)	(dB)	
5350	51.49	-2.11	49.38	74	-24.62	peak
5350	/	-2.11	/	54	/	AVG

Remark: Factor = Antenna Factor + Cable Loss – Pre-amplifier; Level = Reading + Factor; Margin = Level-Limit.

1. If the PK measured levels comply with average limit, then the average level were deemed to comply with average limit.
2. In restricted bands of operation, the spurious emissions below the permissible value more than 20dB.
3. The amplitude of spurious emissions which are attenuated by more than 20dB below the permissible value has no need to be reported.

4.7. Spurious Emission

4.7.1.1. Test Specification

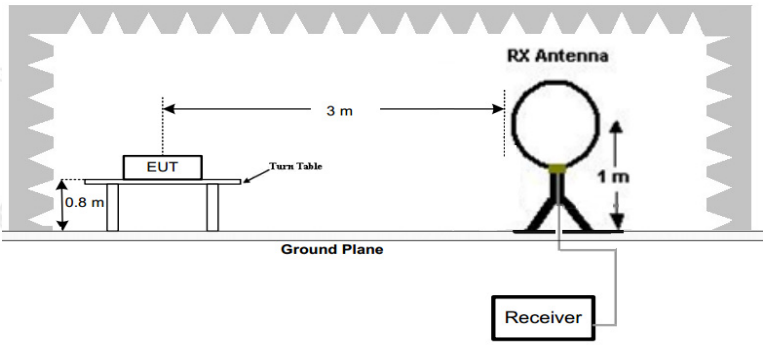
Test Requirement:	FCC CFR47 Part 15 Section 15.407				
Test Method:	KDB 789033 D02 v02r01				
Frequency Range:	9kHz to 40GHz				
Measurement Distance:	3 m				
Antenna Polarization:	Horizontal & Vertical				
Operation mode:	Transmitting mode with modulation				
Receiver Setup:	Frequency	Detector	RBW	VBW	Remark
	9kHz- 150kHz	Quasi-peak	200Hz	1kHz	Quasi-peak Value
	150kHz- 30MHz	Quasi-peak	9kHz	30kHz	Quasi-peak Value
	30MHz-1GHz	Quasi-peak	120KHz	300KHz	Quasi-peak Value
	Above 1GHz	Peak	1MHz	3MHz	Peak Value
		Peak	1MHz	10Hz	Average Value
Limit:	<p>(1) For transmitters operating in the 5.15-5.25 GHz band: All emissions outside of the 5.15-5.35 GHz band shall not exceed an e.i.r.p. of -27 dBm/MHz.</p> <p>(i) All emissions shall be limited to a level of -27 dBm/MHz at 75 MHz or more above or below the band edge increasing linearly to 10 dBm/MHz at 25 MHz above or below the band edge, and from 25 MHz above or below the band edge increasing linearly to a level of 15.6 dBm/MHz at 5 MHz above or below the band edge, and from 5 MHz above or below the band edge increasing linearly to a level of 27 dBm/MHz at the band edge.</p> <p>The limit of frequency below 1GHz and which fall in rest ricted bands should complies 15.209.</p>				
Test setup:	<p>For radiated emissions below 30MHz</p>  <p>30MHz to 1GHz</p>				

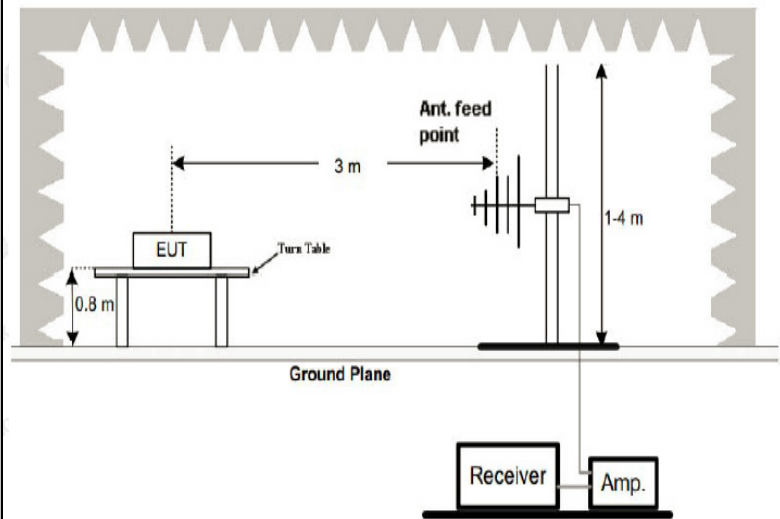

Above 1GHz

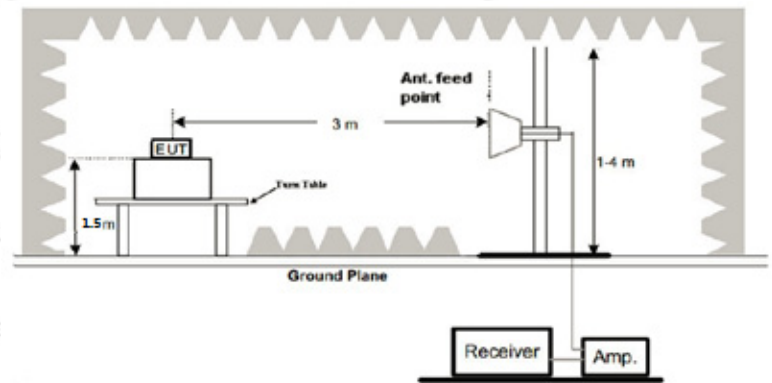
**Test Procedure:**

1. The EUT was placed on the top of a rotating table 0.8 meters above the ground at a 3 meter camber. The table was rotated 360 degrees to determine the position of the highest radiation.
2. The EUT was set 3 meters away from the interference-receiving antenna, which was mounted on the top of a variable-height antenna tower.
3. The antenna height is varied from one meter to four meters above the ground to determine the maximum value of the field strength. Both horizontal and vertical polarizations of the antenna are set to make the measurement.
4. For each suspected emission, the EUT was arranged to its worst case and then the antenna was tuned to heights from 1 meter to 4 meters and the rotatable was turned from 0 degrees to 360 degrees to find the maximum reading.
5. The test-receiver system was set to Peak Detect Function and Specified Bandwidth with Maximum Hold Mode.



Test Procedure:	6. If the emission level of the EUT in peak mode was 10dB lower than the limit specified, then testing could be stopped and the peak values of the EUT would be reported. Otherwise the emissions that did not have 10dB margin would be re-tested one by one using peak, quasi-peak or average method as specified and then reported in a data sheet.
Test results:	PASS



4.7.2. Test Data

All the test modes completed for test. only the worst result of (802.11a at 5180MHz) was reported Below 1GHz

Horizontal

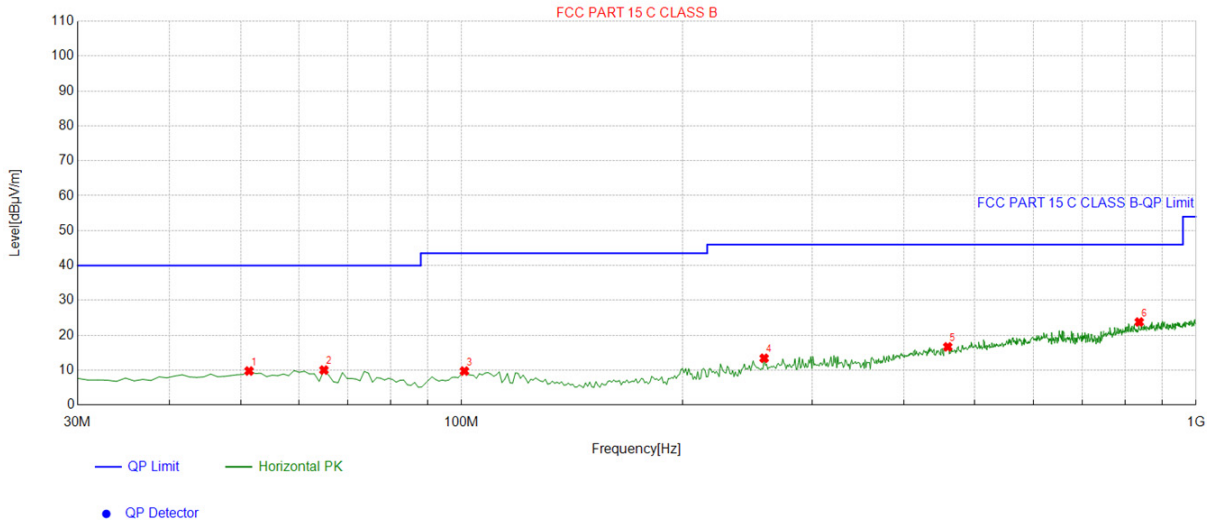

Suspected List									
NO.	Freq. [MHz]	Factor [dB]	Reading [dBµV/m]	Level [dBµV/m]	Limit [dBµV/m]	Margin [dB]	Height [cm]	Angle [°]	Polarity
1	51.361361	-14.38	24.14	9.76	40.00	30.24	100	152	Horizontal
2	64.954955	-14.58	24.61	10.03	40.00	29.97	100	56	Horizontal
3	100.88088	-15.09	24.83	9.74	43.50	33.76	100	326	Horizontal
4	258.17817	-12.84	26.25	13.41	46.00	32.59	100	100	Horizontal
5	459.16916	-8.44	25.12	16.68	46.00	29.32	100	152	Horizontal
6	836.87687	-1.42	25.21	23.79	46.00	22.21	100	356	Horizontal

Remark: Factor = Cable loss + Antenna factor – Preamplifier; Level = Reading + Factor; Margin = Limit – Level



Vertical

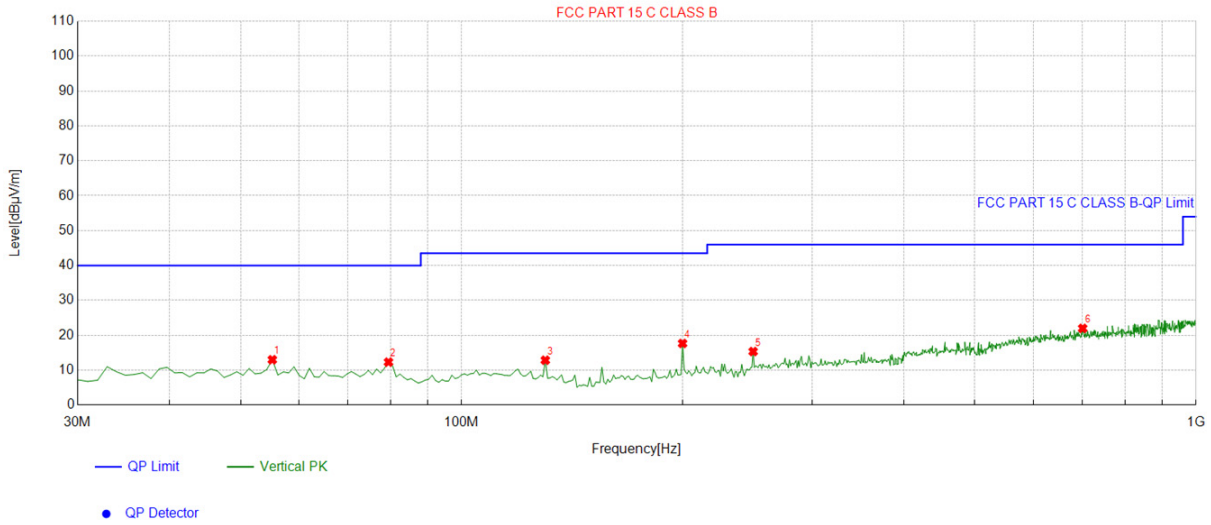

Suspected List									
NO.	Freq. [MHz]	Factor [dB]	Reading [dBµV/m]	Level [dBµV/m]	Limit [dBµV/m]	Margin [dB]	Height [cm]	Angle [°]	Polarity
1	55.245245	-14.32	27.31	12.99	40.00	27.01	100	170	Vertical
2	79.51952	-17.40	29.71	12.31	40.00	27.69	100	210	Vertical
3	130.01001	-17.44	30.29	12.85	43.50	30.65	100	189	Vertical
4	199.91992	-15.27	32.93	17.66	43.50	25.84	100	115	Vertical
5	249.43943	-13.15	28.49	15.34	46.00	30.66	100	93	Vertical
6	700.94094	-3.72	25.70	21.98	46.00	24.02	100	104	Vertical

Remark: Factor = Cable loss + Antenna factor – Preamplifier; Level = Reading + Factor; Margin = Limit – Level



Above 1GHz

LOW CH 36 (802.11 a Mode with 5.2G)/5180

Horizontal:

Frequency	Meter Reading	Factor	Emission Level	Limits	Margin	Detector Type
(MHz)	(dBμV)	(dB)	(dBμV/m)	(dBμV/m)	(dB)	
3647	57.62	-4.59	53.03	74	-20.97	peak
3647	45.23	-4.59	40.64	54	-13.36	AVG
10360	50.23	3.74	53.97	74	-20.03	peak
10360	43.79	3.74	47.53	54	-6.47	AVG

Remark: Factor = Antenna Factor + Cable Loss – Pre-amplifier; Level = Reading + Factor; Margin = Level-Limit.

Vertical:

Frequency	Meter Reading	Factor	Emission Level	Limits	Margin	Detector Type
(MHz)	(dBμV)	(dB)	(dBμV/m)	(dBμV/m)	(dB)	
3647	55.43	-4.59	50.84	74	-23.16	peak
3647	46.24	-4.59	41.65	54	-12.35	AVG
10360	50.12	3.74	53.86	74	-20.14	peak
10360	44.29	3.74	48.03	54	-5.97	AVG

Remark: Factor = Antenna Factor + Cable Loss – Pre-amplifier; Level = Reading + Factor; Margin = Level-Limit.



MID CH40 (802.11 a Mode with 5.2G)/5200

Horizontal:

Frequency (MHz)	Meter Reading (dBµV)	Factor (dB)	Emission Level (dBµV/m)	Limits (dBµV/m)	Margin (dB)	Detector Type
3647	55.34	-4.59	50.75	74	-23.25	peak
3647	47.12	-4.59	42.53	54	-11.47	AVG
10400	50.22	3.74	53.96	74	-20.04	peak
10400	45.49	3.74	49.23	54	-4.77	AVG

Remark: Factor = Antenna Factor + Cable Loss – Pre-amplifier; Level = Reading + Factor; Margin = Level-Limit.

Vertical:

Frequency (MHz)	Meter Reading (dBµV)	Factor (dB)	Emission Level (dBµV/m)	Limits (dBµV/m)	Margin (dB)	Detector Type
3647	56.33	-4.59	51.74	74	-22.26	peak
3647	45.17	-4.59	40.58	54	-13.42	AVG
10400	50.08	3.74	53.82	74	-20.18	peak
10400	43.46	3.74	47.2	54	-6.8	AVG

Remark: Factor = Antenna Factor + Cable Loss – Pre-amplifier; Level = Reading + Factor; Margin = Level-Limit.



HIGH CH 48 (802.11a Mode with 5.2G)/5240

Horizontal:

Frequency (MHz)	Meter Reading (dBμV)	Factor (dB)	Emission Level (dBμV/m)	Limits (dBμV/m)	Margin (dB)	Detector Type
3647	57.21	-4.59	52.62	74	-21.38	peak
3647	43.61	-4.59	39.02	54	-14.98	AVG
10480	50.04	3.75	53.79	74	-20.21	peak
10480	41.88	3.75	45.63	54	-8.37	AVG

Remark: Factor = Antenna Factor + Cable Loss – Pre-amplifier; Level = Reading + Factor; Margin = Level-Limit.

Vertical:

Frequency (MHz)	Meter Reading (dBμV)	Factor (dB)	Emission Level (dBμV/m)	Limits (dBμV/m)	Margin (dB)	Detector Type
3647	57.13	-4.59	52.54	74	-21.46	peak
3647	44.09	-4.59	39.5	54	-14.5	AVG
10480	50.11	3.75	53.86	74	-20.14	peak
10480	42.19	3.75	45.94	54	-8.06	AVG

Remark: Factor = Antenna Factor + Cable Loss – Pre-amplifier; Level = Reading + Factor; Margin = Level-Limit.

Remark:

- (1) Measuring frequencies from 1 GHz to the 40 GHz.
- (2) "F" denotes fundamental frequency; "H" denotes spurious frequency; "E" denotes band edge frequency.
- (3) * denotes emission frequency which appearing within the Restricted Bands specified in provision of 15.205, then the general radiated emission limits in 15.209 apply.
- (4) The emissions are attenuated more than 20dB below the permissible limits are not recorded in the report.
- (5) The IF bandwidth of EMI Test Receiver between 30MHz to 1GHz was 120KHz, 1 MHz for measuring above 1 GHz, below 30MHz was 10KHz.
- (6) When the test results of Peak Detected below the limits of Average Detected, the Average Detected is not need completed. For example: Top Channel at Fundamental 73.16dBuV/m(PK Value) <93.98(AV Limit), at harmonic 53.20 dBuV/m(PK Value) <54 dBuV/m(AV Limit), the Average Detected not need to completed.



4.8. Frequency Stability Measurement

4.8.1. Test Specification

Test Requirement:	FCC Part15 Section 15.407(g)
Test Method:	ANSI C63.10: 2013
Limit:	The frequency tolerance shall be maintained within the band of operation frequency over a temperature variation of 0 degrees to 35 degrees C at normal supply voltage, and for a variation in the primary supply voltage from 85% to 115% of the rated supply voltage at a temperature of 20 degrees C.
Test Setup:	<pre> graph LR SA[Spectrum Analyzer] --- EUT[EUT] subgraph TC [Temperature Chamber] EUT end P[AC/DC Power supply] --- EUT </pre>
Test Procedure:	The EUT was placed inside the environmental test chamber and powered by nominal AC/DC voltage. b. Turn the EUT on and couple its output to a spectrum analyzer. c. Turn the EUT off and set the chamber to the highest temperature specified. d. Allow sufficient time (approximately 30 min) for the temperature of the chamber to stabilize. e. Repeat step 2 and 3 with the temperature chamber set to the lowest temperature. f. The test chamber was allowed to stabilize at +20 degree C for a minimum of 30 minutes. The supply voltage was then adjusted on the EUT from 85% to 115% and the frequency record.
Test Result:	PASS
Remark:	N/A



4.8.2. Test Instruments

RF Test Room					
Equipment	Manufacturer	Model	Serial Number	Calibration Date	Calibration Due
Spectrum analyzer	Agilent	N9020A	HKE-048	Feb. 17, 2023	Feb. 16, 2024
Temperature and humidity meter	Boyang	HTC-1	HKE-077	Feb. 17, 2023	Feb. 16, 2024
programmable power supply	Agilent	E3646A	HKE-092	Feb. 17, 2023	Feb. 16, 2024

Note: The calibration interval of the above test instruments is 12 months and the calibrations are traceable to international system unit (SI).



Test Result as follows:

Mode	Voltage (V)	FHL (5180MHz)	Deviation (KHz)	FHH (5240MHz)	Deviation (KHz)
5.2G Band	4.25V	5179.963	-37	5239.977	-23
	5V	5179.972	-28	5239.961	-39
	5.75V	5179.986	-14	5239.958	-42

Mode	Temperature (°C)	FHL (5180MHz)	Deviation (KHz)	FHH (5240MHz)	Deviation (KHz)
5.2G Band	-30	5179.971	-29	5239.943	-57
	-20	5179.962	-38	5239.955	-45
	-10	5180.022	22	5239.984	-16
	0	5179.985	-15	5239.971	-29
	10	5179.973	-27	5239.959	-41
	20	5179.988	-12	5239.966	-34
	30	5179.957	-43	5239.979	-21
	40	5179.979	-21	5239.951	-49
	50	5179.967	-33	5239.969	-31

The results shown in this test report refer only to the sample(s) tested unless otherwise stated and the sample(s) are retained for 30 days only. The document is issued by HUAK, this document cannot be reproduced except in full with our prior written permission. The more details and the authenticity of the report will be confirmed at <http://www.cer-mark.com>.

TEL : +86-755 2302 9901 FAX : +86-755 2302 9901 E-mail : service@cer-mark.com

Add: 1-2F., Building B2, Junfeng Zhongcheng Zhizao Innovation Park, Heping Community, Fuhai Street, Bao'an District, Shenzhen, Guangdong, China

4.9. Antenna Requirement

Standard Applicable

For intentional device, according to FCC 47 CFR Section 15.203, an intentional radiator shall be designed to ensure that no antenna other than that furnished by the responsible party shall be used with the device.

Refer to statement below for compliance.

The manufacturer may design the unit so that the user can replace a broken antenna, but the use of a standard antenna jack or electrical connector is prohibited. Further, this requirement does not apply to intentional radiators that must be professionally installed.

Antenna Connected Construction

The antenna used in this product is a Internal Antenna, need professional installation. It conforms to the standard requirements. The directional gains of antenna used for transmitting is 1.1dBi.

Antenna





5. Photographs of Test Setup

Radiated Emission

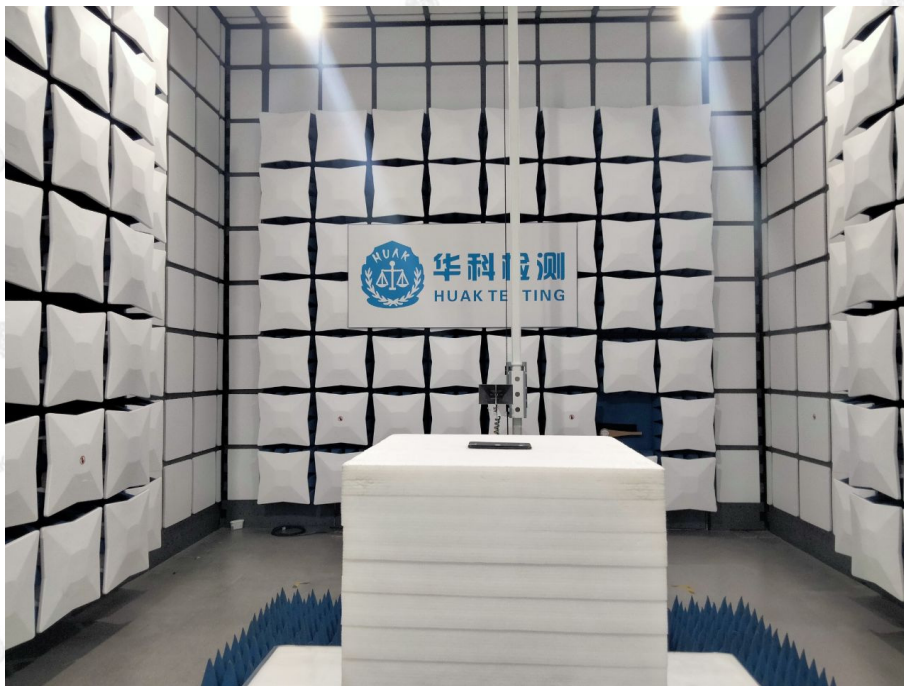
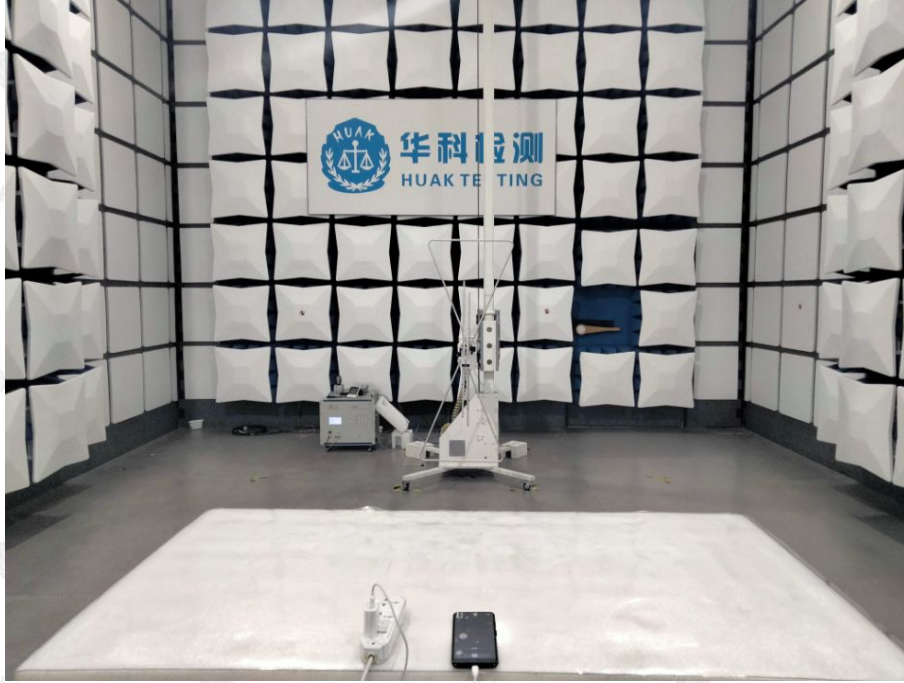

The results shown in this test report refer only to the sample(s) tested unless otherwise stated and the sample(s) are retained for 30 days only. The document is issued by HUAKE, this document cannot be reproduced except in full with our prior written permission. The more details and the authenticity of the report will be confirmed at <http://www.cer-mark.com>.

TEL : +86-755 2302 9901 FAX : +86-755 2302 9901 E-mail : service@cer-mark.com

Address: 1-2F., Building B2, Junfeng Zhongcheng Zhizao Innovation Park, Heping Community, Fuhai Street, Bao'an District, Shenzhen, Guangdong, China



Conducted Emission



The results shown in this test report refer only to the sample(s) tested unless otherwise stated and the sample(s) are retained for 30 days only. The document is issued by HUAK, this document cannot be reproduced except in full with our prior written permission. The more details and the authenticity of the report will be confirmed at <http://www.cer-mark.com>.

TEL : +86-755 2302 9901 FAX : +86-755 2302 9901 E-mail : service@cer-mark.com

Addr: 1-2F., Building B2, Junfeng Zhongcheng Zhizao Innovation Park, Heping Community, Fuhai Street, Bao'an District, Shenzhen, Guangdong, China



6. Photos of the EUT

Reference to the report: ANNEX A of external photos and ANNEX B of internal photos.

-----End of test report-----