

# acknowledgement

## SPECIFICATION FOR APPROVAL

client: CUSTOMER :	
Customer Material Number: CUST P/N :	
Material No.: FINE P/N :	<b>G43.5-6.5uH single coil 0.07 * 100P * 10TS</b>
product model: DESC :	<b>Φ 43.5MMX5.0MMX0.65MM</b>
date: DATE :	<b>2023/11/07</b>
edition: Version:	<b>A.0</b>

fiction PREPARED BY	examine and verify CHECKED BY	ratify APPROVED BY	Customer acknowledges CUSTOMER APPROVE
Yan-ming huang	Ning Yuan'an	Huang Jinhua	

## Shenzhen Songtao Technology Co., LTD

Factory address: 8th floor, Building 2, Grade A High-tech Industrial Park, No.123,  
Junfa Third Road, Dongkeng Town, Dongguan City

TEL : 13728755750

E-mail : 506388681@QQ .com



# SPECIFICATION

DESC	Φ 20.5x41-6.5uH-0.07x100-230mm	Rev: A.0	CUST:	<b>XXX</b>
			CUST P / N:	

一、 DIMENSION: (mm)

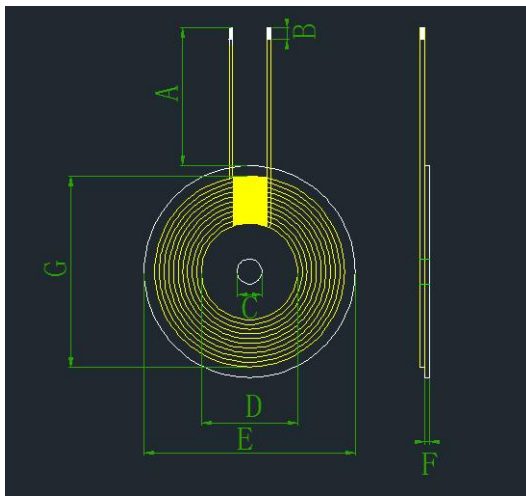

A	230±2
B	4±2
C	5.3±0.5
D	20.5±0.5
E	43.5±0.5
F	0.65±0.2
G	41.0±0.5

pour :

1. Cross line;
2. 8mm (ref) width high temperature adhesive tape 1-2Ts;
3. The coil is affixed with circular hard magnetic sheet with groove, magnetic plate size 43.5 ± 0.5mm, inner hole 5.3mm, thickness of 0.65 ± 0.2mm, back glue.

2. A Schematic diagram of the SCHEMATIC D I AGRAM:

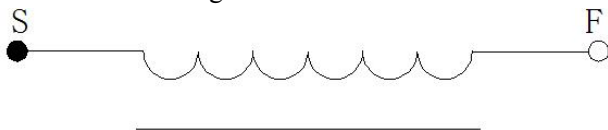

三、 Winding parameter Winding Spec ification:

NO.	TERMINAL	WIRE	Turns	Winding Direction
1	S    F	0.07 * 100P	10Ts	CCW

4. ELECTRICAL CHARA C TERISTICS:

TEMPERATURE: 25 ± 10°C, RELATIVE HUMIDITY: 65 ± 20%

NO.	ITEM	TERMINAL	SPEC IFICATION	TEST FREQUENCY	TEST EQUIPMENTS
1	IND .	S-F	And 3.8 uH ± 20% of individual coils	100KH z /0.25V	LCZ METER 1062B
2	IND .	S-F	6.5 uH ± 10% with a magnetic chip	100KH z /0.25V	LCZ METER 1062B
3	DCR	S-F	≤ 58m Ω	100KH z /0.25V	LCZ METER 502B
4	Q price	S-F	≥ 50	100KH z /0.25V	LCZ METER 502B

PREPARED BY / DATE	CHECKED BY / DATE
--------------------	-------------------

Huang Yanming 2023 / 11 / 07	Huang Jinhua 2023 / 11 / 07
------------------------------	-----------------------------