

6+

## CONTENTS AND BATTERY

### Contents

- 1 Cyclone Twister
- 1 Remote Control
- 1 USB-C Cable

### Charging the Battery

#### CAUTION:

If the rechargeable battery leaks fluid, dispose of the stunt vehicle immediately. Do not allow fluid to come in contact with skin or eyes.

1. Make sure the power switch located at the back of the vehicle is turned to the off position.
2. Insert the USB-C charging cable into the port located at the back of the vehicle.

**IMPORTANT:** Do not use excessive force when connecting the USB-C cable. Connect the other end of the USB-C charging cable into your charging source.

4. Note: The average charging time is approximately 80 minutes (via 5.0V/2A USB wall charger).

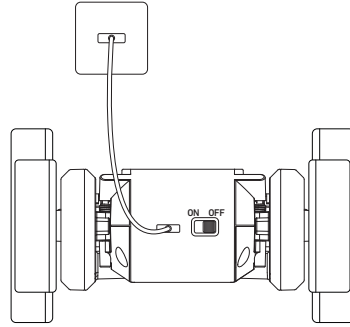

### Battery Installation

1. The remote control requires 2 AAA 1.5V batteries (not included).
2. Use a tool to press and hold the battery release button on the back of the remote control.
3. Slide down the battery cover.
4. Insert batteries as indicated in the diagram.
5. Slide the battery cover back into place securely.

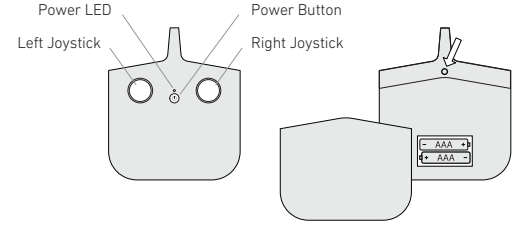

### Pairing

The stunt vehicle utilizes an automatic 2.4GHz digital channel selection system that allows up to 10 individual players to race side by side in the same wireless range without interference.

### For Solo Drivers

1. Make sure both the vehicle and the remote control are powered off.
2. Power on the remote control by pressing the power button. The remote control will enter pairing mode and the LED indicator will slowly flash.
3. Power on the stunt vehicle by flipping the power switch and set the vehicle down on a flat surface.
4. Wait for the remote control to quit flashing. The remote control LED will remain lit once paired.
5. If pairing is unsuccessful within 60 seconds, please power off both the vehicle and the remote control before repeating steps 2 to 4.
6. Start Driving.

### Forward

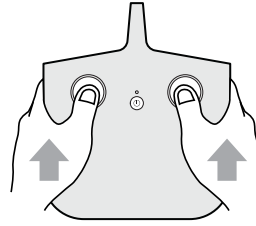
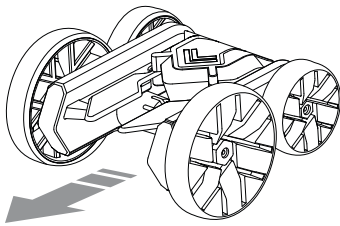

### Reverse

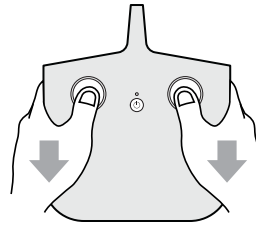
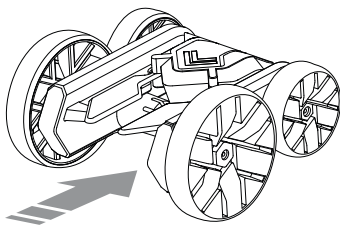

### 360° Rotation

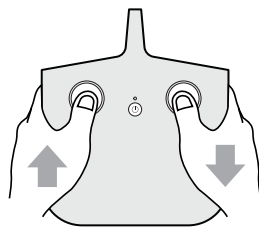
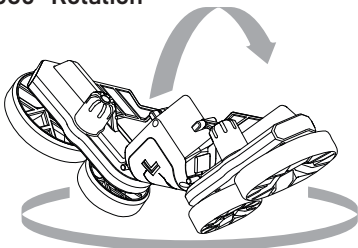

OR

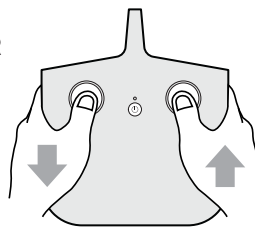

### Stunt

When the vehicle is moving forward or backward, quickly push the both joysticks in the same direction but opposite to the direction of the vehicle moving to turn the vehicle upside down.

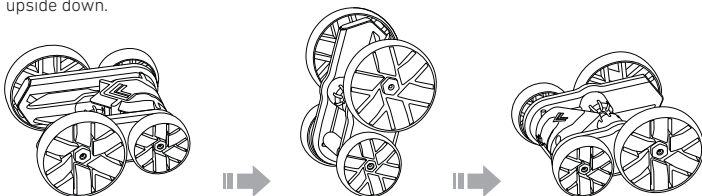

## SAFETY PRECAUTIONS

- Do not sit, step, stand, or place objects on the vehicle. It is not designed to support extra weight.
- Adult supervision is recommended when operating the vehicle.
- Always drive responsibly and make sure driving paths are clear. Never drive towards or in close proximity to people or animals.
- Never submerge the vehicle in water and avoid driving the vehicle through water. The vehicle can handle minor splashes of mud and moisture, but it is not waterproof.
- Keep fingers, hair, and loose clothing away from tires and all moving parts while the vehicle is in motion.
- Do not expose to extreme temperatures.
- Do not leave vehicle or remote control near sources of heat or under direct sunlight for long periods of time.
- Thoroughly inspect products before every use. If the product appears worn, frayed, splintered, cracked, or broken in any manner, discontinue use and discard immediately.

### BATTERY WARNINGS

- Do not mix old and new batteries.
- Do not mix alkaline, standard (carbon-zinc), or rechargeable batteries.
- Alkaline batteries are recommended. Use only the specified voltage.
- Insert batteries using the correct polarity. Always use, replace, and recharge (if applicable) batteries under adult supervision.
- Do not charge with non-rechargeable batteries.
- Do not short-circuit the battery supply terminals.
- Do not dispose of batteries in fire, batteries may explode or leak.
- Remove batteries (if removable) before storing.
- Recycle or dispose of batteries according to federal, state, and local laws.

### RECHARGEABLE BATTERY WARNINGS

- There is a risk of fire and personal injury if battery is punctured, damaged, or misused.
- Do not dismantle, crush, incinerate or short-circuit battery.
- Never expose battery to extreme temperatures or moisture.
- Keep away from flammable materials and direct sunlight.
- Only charge using the provided charger, cable, and/or adapters.
- Rechargeable battery is only to be charged by an adult.
- Adult Supervision of the battery while it is charging is required.
- Allow battery to cool to room temperature before charging.
- Charge on a non-flammable surface and keep away from flammable products.
- Discontinue charging if battery becomes hot, swells, smokes, or gives off a strong odor.
- Battery chargers used with the product are to be regularly examined for damage to the cord, plug, enclosure, and other parts, and in the event of such damage, they must not be used until the damage has been repaired.
- Recycle or dispose of battery according to federal, state, and local laws.
- Keep these instructions for future reference.

This device complies with Part 15 of the FCC Rules. Operation is subject to the following two conditions: (1) this device may not cause harmful interference, and (2) this device must accept any interference received, including interference that may cause undesired operation.

**NOTE:** This equipment has been tested and found to comply with the limits for a Class B digital device, pursuant to Part 15 of the FCC Rules. These limits are designed to provide reasonable protection against harmful interference in a residential installation. This equipment generates, uses and can radiate radio frequency energy and, if not installed and used in accordance with the instructions, may cause harmful interference to radio communications.

However, there is no guarantee that interference will not occur in a particular installation. If this equipment does cause harmful interference to radio or television reception, which can be determined by turning the equipment off and on, the user is encouraged to try to correct the interference by one or more of the following measures:

- Reorient or relocate the receiving antenna.
- Increase the separation between the equipment and receiver.
- Connect the equipment into an outlet on a circuit different from that to which the receiver is connected.
- Consult the dealer or an experienced radio/TV technician for help.

**Warning:** Changes or modifications not expressly approved by the party responsible for compliance could void the user's authority to operate the equipment.

Sharper Image® name and logo (including the 77 logo and Tomorrow's Tomorrow) are trademarks or registered trademarks. Distributed by and © 2023 MerchSource, LLC. Irvine, CA 92618. All rights reserved.

Model No.: 1017806

**WARNING:**  
CHOKING HAZARD – Small Parts.  
Not for children under 3 years of age.



KEEP THIS INSTRUCTION MANUAL AS IT CONTAINS IMPORTANT INFORMATION FOR FUTURE REFERENCE.

Due to continuous product improvements, the pictures on this manual may differ slightly from the actual product.

Printed in China

**FOR CUSTOMER SUPPORT,  
PLEASE CALL**

**1-800-374-2744**