

Test Report

Product: SMART LOCK

Trade Mark: smonet/hornbill

Model Number: M6

FCC ID: 2BD7X-M6

Prepared for

Hongling smart link LLC

Baoneng Park, Qinghu Industrial, Bantian Street, Longgang District,
Shenzhen, China

Prepared by

Shenzhen HongBiao Certification& Testing Co., Ltd

Room 102, 201, Building 2, Yuanwanggu RFID Industrial Park, Tongguan
Road, Tianliao Community, Yutang Street, Guangming District, Shenzhen,
China

Tel.: +86-755-2998 9321 Fax.: +86-755-2998 5110

Website: <http://www.sz-hongbiao.com>

Table of Contents

1	GENERAL DESCRIPTION	5
1.1	DESCRIPTION OF EUT.....	5
1.2	TEST MODE.....	5
1.3	TEST SETUP.....	5
1.4	ANCILLARY EQUIPMENT	5
2	SUMMARY OF TEST RESULT	6
3	TEST FACILITIES AND ACCREDITATIONS	7
3.1	TEST LABORATORY	7
3.2	ENVIRONMENTAL CONDITIONS.....	7
3.3	MEASUREMENT UNCERTAINTY	7
3.4	TEST SOFTWARE	7
4	LIST OF TEST EQUIPMENT	8
5	TEST ITEM AND RESULTS.....	10
5.1	ANTENNA REQUIREMENT.....	10
5.2	CONDUCTED EMISSION.....	11
5.3	RADIATED EMISSION	15
5.4	OUT OF BAND EMISSIONS	20
5.5	FREQUENCY STABILITY	22
5.6	OCCUPIED BANDWIDTH	23
6	PHOTOGRAPHS OF THE TEST SETUP.....	24
7	PHOTOGRAPHS OF THE EUT.....	25

1 General Description

1.1 Description of EUT

Product name:	SMART LOCK
Model name:	M6
Series Model:	Y1, Y2, Y3, Y4, Y5, Y6, Y7, Y8, Y9, A1, A2, A3, A4, A5, A6, A7, A8, A9, M1, M2, M3, M4, M5, M7, M8, M9, H1, H2, H3, H4, H5, H6, H8, H9, H10, H11, D1, D2, D3, D4, D5, D6, D7, DS2, G2, G3, G4, G5, T1, T2, T3, T7, T5, T6
Different of series model:	The color of appearance and model name of series models listed are different from the main model, but the circuit and the electronic construction are the same, declared by the manufacturer.
Operation frequency:	13.56MHz
Modulation type:	ASK
Antenna type:	Loop Antenna
Antenna gain:	0dBi
Hardware version:	bk3435_ble_fcc_crc_V2.0
Software version:	ZYX(012)MAIN V1.0
Power supply:	DC 6.0V From Battery and DC 5.0V From USB
Adapter information:	N/A

1.2 Test Mode

Test Mode	Description	Frequency (MHz)
1	Transmitting	13.56

1.3 Test Setup

See photographs of the test setup in the report for the actual setup and connections between EUT and support equipment.

1.4 Ancillary Equipment

Equipment	Model	S/N	Manufacturer
Adapter	HW-100225C00	/	Huawei

Equipment	Length (cm)	Shielded/Unshielded	With/Without Ferrite
USB A to C Cable	100	Unshielded	Without Ferrite

2 Summary of Test Result

Test procedures according to the technical standards:

FCC Part 15C				
No.	Standard Section	Test Item	Result	Remark
1	FCC Part 15.203	Antenna Requirement	Pass	
2	FCC Part 15.207	Conducted Emission	Pass	
3	FCC Part 15.209	Radiated Emission	Pass	
4	FCC Part 15.215	20dB Bandwidth	Pass	
5	FCC Part 15.225(b)(c)	Out of Band Emissions	Pass	
6	FCC Part 15.225(e)	Frequency Stability	Pass	

Note:

1. "N/A" means the test case does not apply to the test object.

3 Test Facilities and Accreditations

3.1 Test Laboratory

Test Site	Shenzhen HongBiao Certification& Testing Co., Ltd
Test Site Location	Room 102, 201, Building 2, Yuanwanggu RFID Industrial Park, Tongguan Road, Tianliao Community, Yutang Street, Guangming District, Shenzhen, China
Telephone:	(86-755) 2998 9321
Fax:	(86-755) 2998 5110
FCC Registration No.:	CN1341
A2LA Certificate No.:	6765.01

3.2 Environmental Conditions

During the measurement the environmental conditions were within the listed ranges:

Temperature:	15°C~35°C
Relative Humidity:	20%~75%
Air Pressure:	98kPa~101kPa

3.3 Measurement Uncertainty

The reported uncertainty of measurement $y \pm U$, where expanded uncertainty U is based on a standard uncertainty multiplied by a coverage factor of $k=2$, providing a level of confidence of approximately 95 %.

Measurement Frequency Range	U, (dB)	Note
RF frequency	2×10^{-5}	
RF power, conducted	± 0.57 dB	
Conducted emission(150kHz~30MHz)	± 2.5 dB	
Radiated emission(30MHz~1GHz)	± 4.2 dB	
Radiated emission (above 1GHz)	± 4.7 dB	
Occupied bandwidth	± 4 %	
Temperature	± 1 degree	
Humidity	± 5 %	

3.4 Test Software

Software name	Manufacturer	Model	Version
EMI Measurement	Farad	EZ-EMC	V1.1.4.2
Conducted test system	MWRF-test	MTS 8310	V2.0.0

4 List of Test Equipment

Radiation emission							
Item	Equipment No.	Equipment name	Manufacturer	Model	Serial No.	Calibration date	Due date
1	HB-E001	Horn Antenna	Schwarzbeck	BBHA 9120D	02592	2022-04-02	2024-04-01
2	HB-E002	Biconical log-periodic composite antenna	Schwarzbeck	VULB 9168	01340	2022-04-06	2024-04-05
3	HB-E003	SHF-EHF Horn	Schwarzbeck	BBHA 91270	01193	2022-04-02	2024-04-01
4	HB-E004	Preamplifier	Noyetec	LAN-0910	NYCM1420101	2023-05-11	2024-05-10
5	HB-E005	Preamplifier	Noyetec	LAN-0118	NYCM1420102	2023-05-12	2024-05-11
6	HB-E006	Preamplifier	Noyetec	LAN-1840	NYCM1420103	2023-06-11	2024-06-10
7	HB-E007	EMI TEST RECEIVER	R&S	ESR7	102520	2023-05-12	2024-05-11
8	HB-E009	POSITINAL COTROLLE R	Noyetec	N/A	N/A	/	/
9	HB-E013	RF switch	Noyetec	NY-RF4	NY0CM1420204	/	/
10	HB-E066	Illuminance Tester	TASI	TA8121	N/A	2023-05-11	2024-05-10
11	HB-E075	Active loop antenna	Schwarzbeck	FMZB 1519B	1519B-245	2022-07-24	2024-07-23
Conduction emission							
Item	Equipment No.	Equipment name	Manufacturer	Model	Serial No.	Calibration date	Due date
1	HB-E014	4 Path V-LISN	Schwarzbeck	NNLK 8121	00770	2023-05-12	2024-05-11
2	HB-E015	Pulse Limiter	Schwarzbeck	VTSD 9561-F	00949	2023-05-12	2024-05-11
3	HB-E016	ZN23201	Noyetec	ZN23201	N/A	2023-05-11	2024-05-10
4	HB-E059	Attenuator	Xianghua	TS2-6-1	220215166	2023-05-12	2024-05-11
5	HB-E069	EMI TEST RECEIVER	R&S	ESCI	N/A	2023-05-12	2024-05-11
RF							
Item	Equipment No.	Equipment name	Manufacturer	Model	Serial No.	Calibration date	Due date
1	HB-E041	MXG Anaioq Signal Generator	Agilent	N5181A	MY47070421	2023-05-11	2024-05-10
2	HB-E042	WIDEBAND RADIO COMMUNICA	R&S	CMW500	132108	2023-05-11	2024-05-10

		TION TESTER					
3	HB-E043	MXG Anaioq Signal Generator	Agilent	N5182A	US46240335	2023-05-11	2024-05-10
4	HB-E044	Signal& spectrum Analyzer	R&S	FSV3044	101264	2023-05-11	2024-05-10
5	HB-E045	RF Control Box	Noyetec	NY100-R FCB	N/A	/	/
6	HB-E058	Thermometer Clock Humidity Monitor	N/A	HTC-1	N/A	/	/
7	HB-E077	PXA Signal Analyzer	Agilent	N9030A	N/A	2023-05-11	2024-05-10

Note: the calibration interval of the above test instruments is 12&24 months and the calibrations are traceable to international system unit (SI).

5 Test Item And Results

5.1 Antenna Requirement

5.1.1 Standard Requirement

15.203 requirement: For intentional device, according to 15.203: an intentional radiator shall be designed to ensure that no antenna other than that furnished by the responsible party shall be used with the device

5.1.2 Test Result

The EUT antenna is Loop Antenna. It comply with the standard requirement. In case of replacement of broken antenna the same antenna type must be used.

5.2 Conducted Emission

5.2.1 Limits

Limits – Class A		
Frequency (MHz)	Limit (dB μ V)	
	Quasi-Peak	Average
0.15 to 0.5	79	66
0.5 to 30	73	60
Limits – Class B		
Frequency (MHz)	Limit (dB μ V)	
	Quasi-Peak	Average
0.15 to 0.5	66 to 56*	56 to 46*
0.5 to 5	56	46
5 to 30	60	50
Note: 1. the tighter limit applies at the band edges. 2. the limit of " * " marked band means the limitation decreases linearly with the logarithm of the frequency in the range.		

5.2.2 Test Procedures

- a) The EUT was placed 0.8 meters from the horizontal ground plane with EUT being connected to the power mains through a line impedance stabilization network (LISN). All other support equipment powered from additional LISN(s). The LISN provide 50 Ohm/ 50uH of coupling impedance for the measuring instrument.
- b) Interconnecting cables that hang closer than 40 cm to the ground plane shall be folded back and forth in the center forming a bundle 30 to 40 cm long.
- c) I/O cables that are not connected to a peripheral shall be bundled in the center. The end of the cable may be terminated, if required, using the correct terminating impedance. The overall length shall not exceed 1 m.
- d) LISN is at least 80 cm from nearest part of EUT chassis.
- e) For the actual test configuration, please refer to the related Item – photographs of the test setup.

5.2.3 Test setup

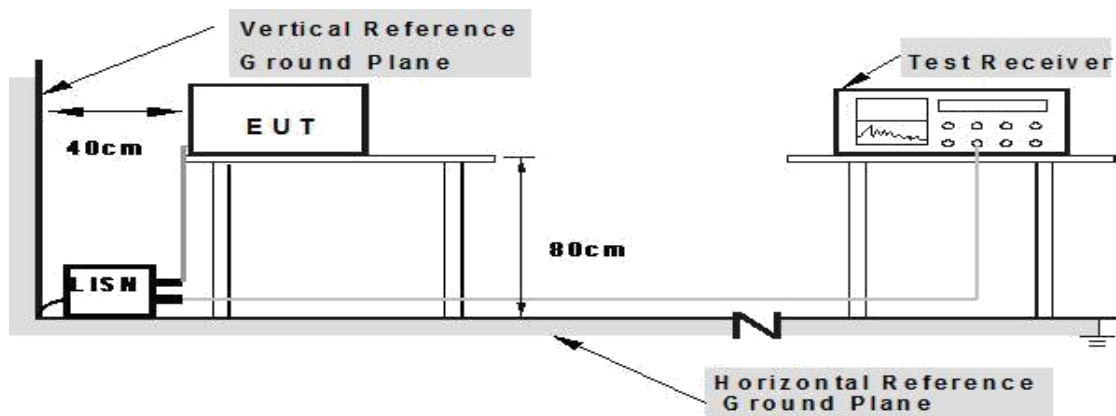

5.2.4 Test Result

EUT:	SMART LOCK	Model Name:	M6
Test Mode:	TM1+Charging	Phase :	L
Test Voltage:	AC 120V/60Hz		

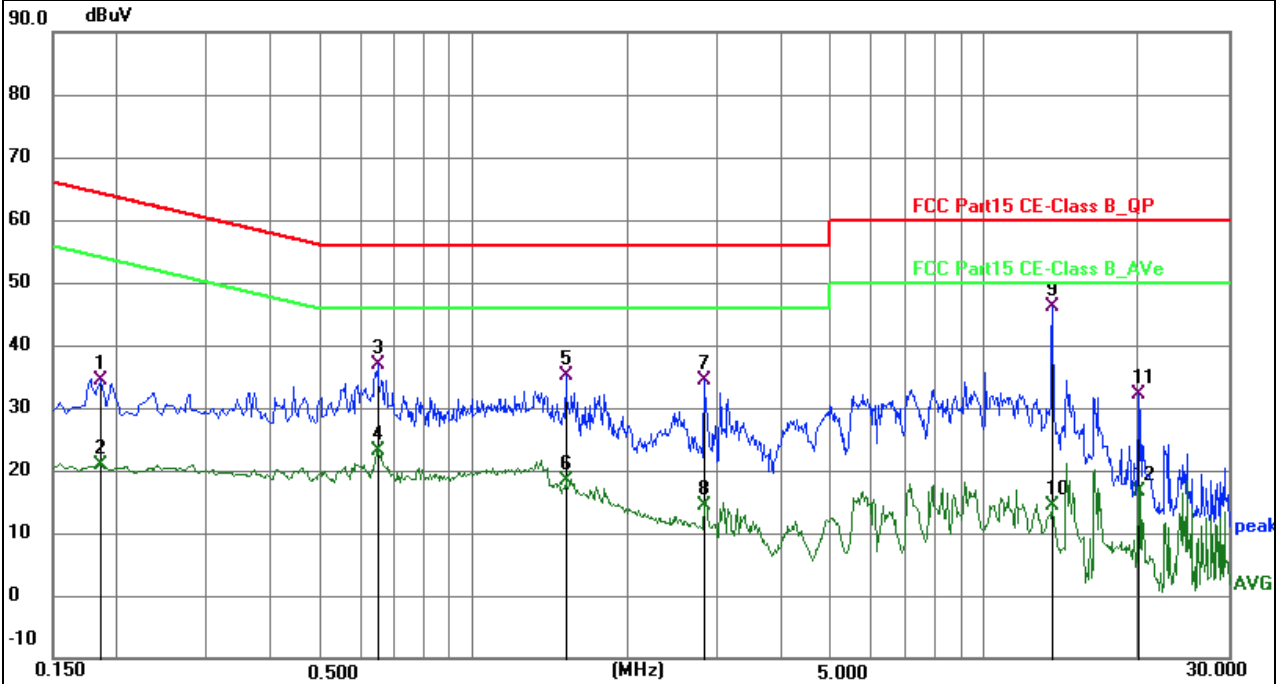

No.	Frequency (MHz)	Reading (dBuV)	Factor (dB)	Level (dBuV)	Limit (dBuV)	Margin (dB)	Detector	P/F	Remark
1	0.1860	25.48	9.01	34.49	64.21	-29.72	QP	P	
2	0.1860	11.80	9.01	20.81	54.21	-33.40	AVG	P	
3	0.6495	26.98	9.90	36.88	56.00	-19.12	QP	P	
4	0.6495	13.24	9.90	23.14	46.00	-22.86	AVG	P	
5	1.5180	25.17	10.03	35.20	56.00	-20.80	QP	P	
6	1.5180	8.25	10.03	18.28	46.00	-27.72	AVG	P	
7	2.8365	24.30	10.10	34.40	56.00	-21.60	QP	P	
8	2.8365	4.34	10.10	14.44	46.00	-31.56	AVG	P	
9 *	13.5735	35.96	10.18	46.14	60.00	-13.86	QP	P	
10	13.5735	4.13	10.18	14.31	50.00	-35.69	AVG	P	
11	20.0040	21.58	10.54	32.12	60.00	-27.88	QP	P	
12	20.0040	6.13	10.54	16.67	50.00	-33.33	AVG	P	

Notes:

1. An initial pre-scan was performed on the line and neutral lines with peak detector.
2. Quasi-Peak and Average measurement were performed at the frequencies with maximized peak emission.
3. Measurement Level = Reading level + Correct Factor
4. All test modes were pre-tested, but we only recorded the worst case in this report.

EUT:	SMART LOCK	Model Name:	M6
Test Mode:	TM1+Charging	Phase :	N
Test Voltage:	AC 120V/60Hz		

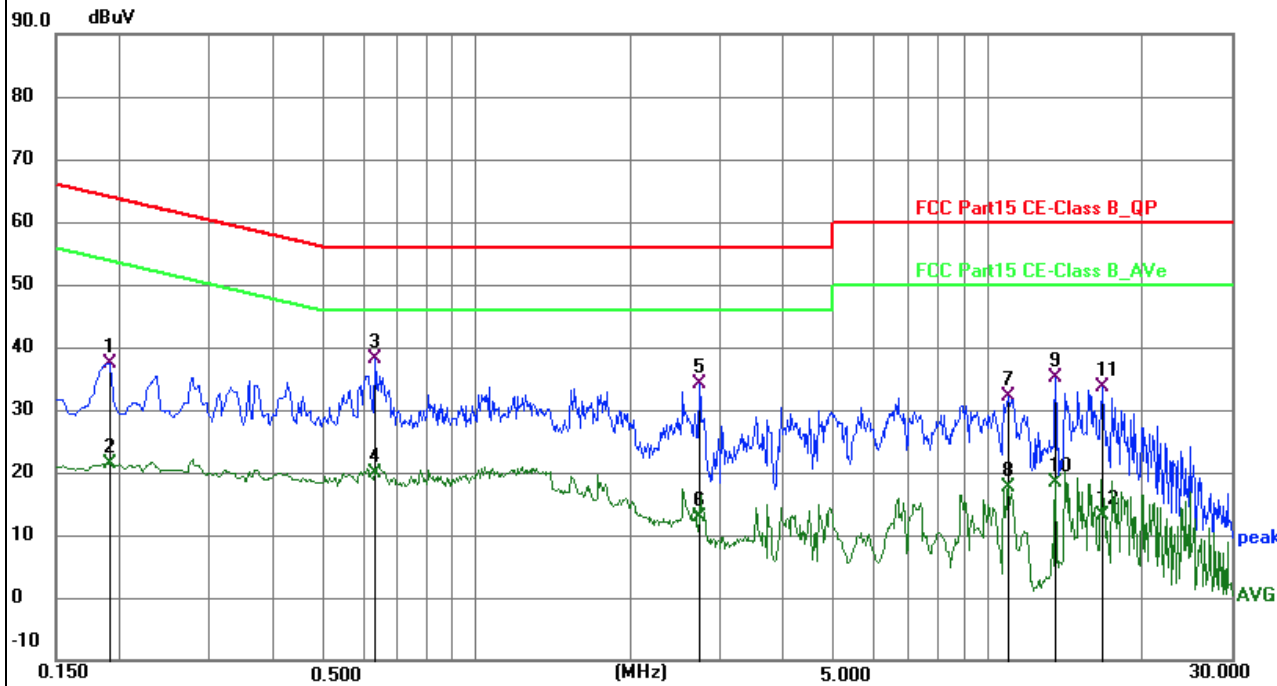

No.	Frequency (MHz)	Reading (dBuV)	Factor (dB)	Level (dBuV)	Limit (dBuV)	Margin (dB)	Detector	P/F	Remark
1	0.1905	27.84	9.44	37.28	64.01	-26.73	QP	P	
2	0.1905	11.94	9.44	21.38	54.01	-32.63	AVG	P	
3 *	0.6315	28.44	9.68	38.12	56.00	-17.88	QP	P	
4	0.6315	10.13	9.68	19.81	46.00	-26.19	AVG	P	
5	2.7330	24.06	10.08	34.14	56.00	-21.86	QP	P	
6	2.7330	2.76	10.08	12.84	46.00	-33.16	AVG	P	
7	10.9860	21.83	10.21	32.04	60.00	-27.96	QP	P	
8	10.9860	7.48	10.21	17.69	50.00	-32.31	AVG	P	
9	13.5555	25.06	10.07	35.13	60.00	-24.87	QP	P	
10	13.5555	8.23	10.07	18.30	50.00	-31.70	AVG	P	
11	16.7955	23.52	10.14	33.66	60.00	-26.34	QP	P	
12	16.7955	2.90	10.14	13.04	50.00	-36.96	AVG	P	

Notes:
 1. An initial pre-scan was performed on the line and neutral lines with peak detector.
 2. Quasi-Peak and Average measurement were performed at the frequencies with maximized peak emission.
 3. Measurement Level = Reading level + Correct Factor
 4. All test modes were pre-tested, but we only recorded the worst case in this report.

5.3 Radiated Emission

5.3.1 Limits

Frequencies (MHz)	Field Strength (micovolts/meter)	Measurement Distance (meters)
0.009~0.490	2400/F(KHz)	300
0.490~1.705	24000/F(KHz)	30
1.705~30.0	30	30
30~88	100	3
88~216	150	3
216~960	200	3
Above 960	500	3

Receiver Parameter	Setting
Attenuation	Auto
Start ~ Stop Frequency	9kHz~150kHz / RB 200Hz for QP
Start ~ Stop Frequency	150kHz~30MHz / RB 9kHz for QP
Start ~ Stop Frequency	30MHz~1000MHz / RB 120kHz for QP

5.3.2 Test Procedures

- a) The radiated emission tests were performed in the 3 meters.
- b) The EUT was placed on the top of a rotating table 0.8 meters above the ground. The table was rotated 360 degrees to determine the position of the highest radiation.
- c) The height of the test antenna shall vary between 1m to 4m. Both horizontal and vertical polarizations of the antenna are set to make the measurement.
- d) If the peak mode measured value compliance with and lower than quasi peak mode limit, the EUT shall be deemed to meet QP limits and then no additional QP mode measurement performed.
- e) If the peak mode measured value compliance with and lower than average mode limit, the EUT shall be deemed to meet average limits and then no additional average mode measurement performed.
- f) For the actual test configuration, please refer to the related item – EUT test photos.

5.3.3 Test Setup

Radiated Emission Test-Up Frequency Below 30MHz

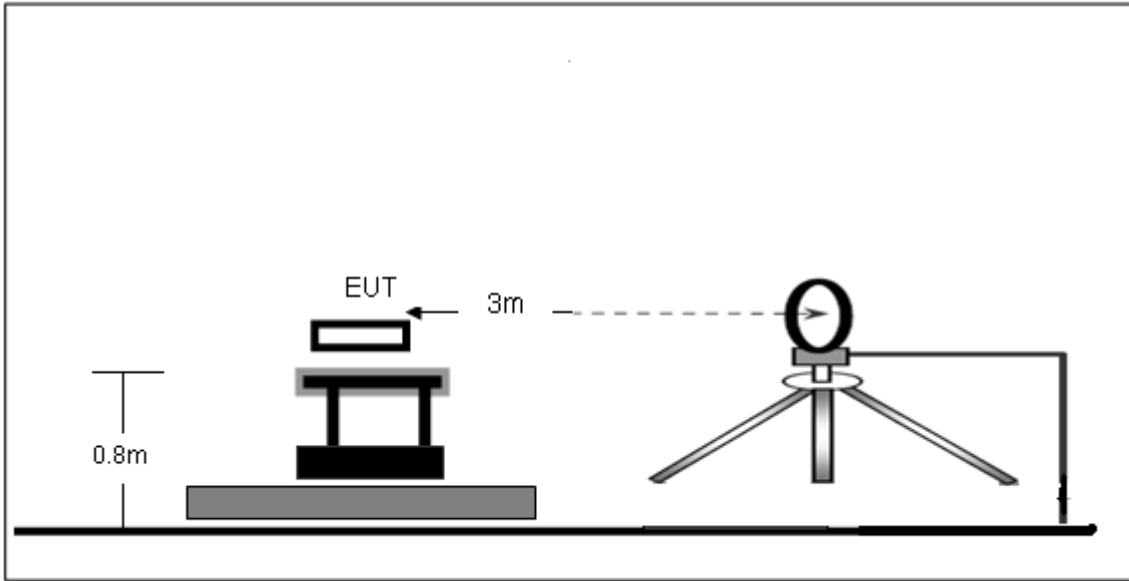

Radiated Emission Test-Up Frequency 30MHz~1GHz

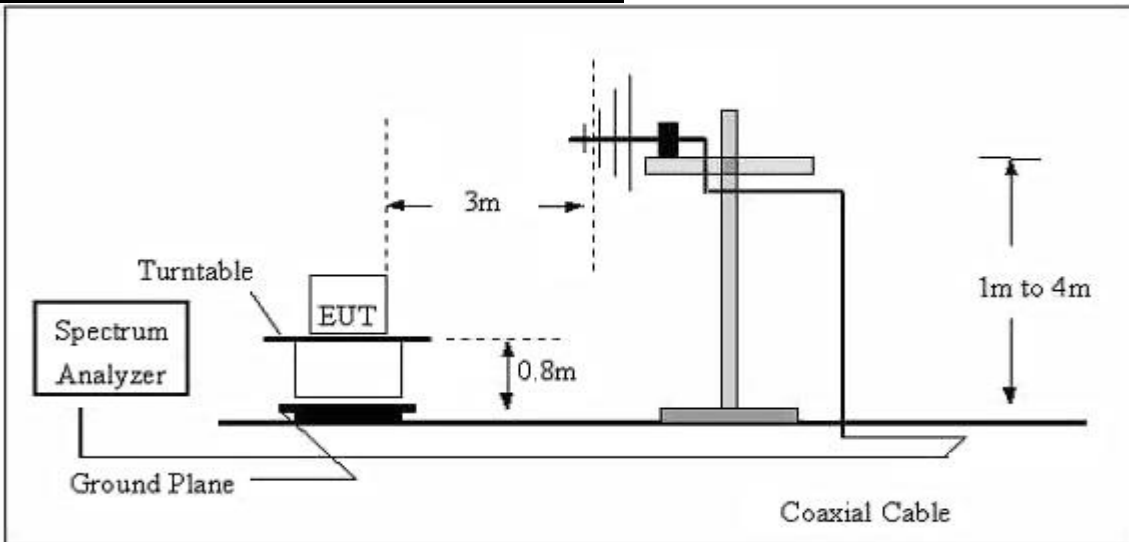

5.3.4 Test Result

Frequency range (9kHz – 30MHz)

EUT:	SMART LOCK	Model Name:	M6
Test Mode:	TM1	Phase :	Coplaner
Test Voltage:	DC 6V from battery		

Freq.	Reading	Limit	Margin	State
(MHz)	(dBuV/m)	(dBuV/m)	(dB)	P/F
0.0200	45.86	121.57	-75.71	Pass
0.0454	46.96	114.45	-67.49	Pass
0.0857	38.80	108.94	-70.14	Pass
0.0909	37.92	108.42	-70.50	Pass
0.1008	37.58	107.53	-69.95	Pass
0.8002	46.76	69.54	-22.78	Pass

EUT:	SMART LOCK	Model Name:	M6
Test Mode:	TM1	Phase :	coaxial
Test Voltage:	DC 6V from battery		

Freq.	Reading	Limit	Margin	State
(MHz)	(dBuV/m)	(dBuV/m)	(dB)	P/F
0.0205	45.86	121.35	-75.49	Pass
0.0468	46.52	114.19	-67.67	Pass
0.0855	38.80	108.96	-70.16	Pass
0.1010	40.27	107.51	-67.24	Pass
0.8304	47.10	69.21	-22.11	Pass
4.6962	37.64	69.50	-31.86	Pass

Note:

Limit dBuV/m @3m = Limit dBuV/m @300m+ 80

Limit dBuV/m @3m = Limit dBuV/m @30m + 40

Margin = Reading - Limit.

Frequency range (30MHz – 1GHz)

EUT:	SMART LOCK	Model Name:	M6
Test Mode:	TM1	Phase :	Horizontal
Test Voltage:	DC 6V from battery		

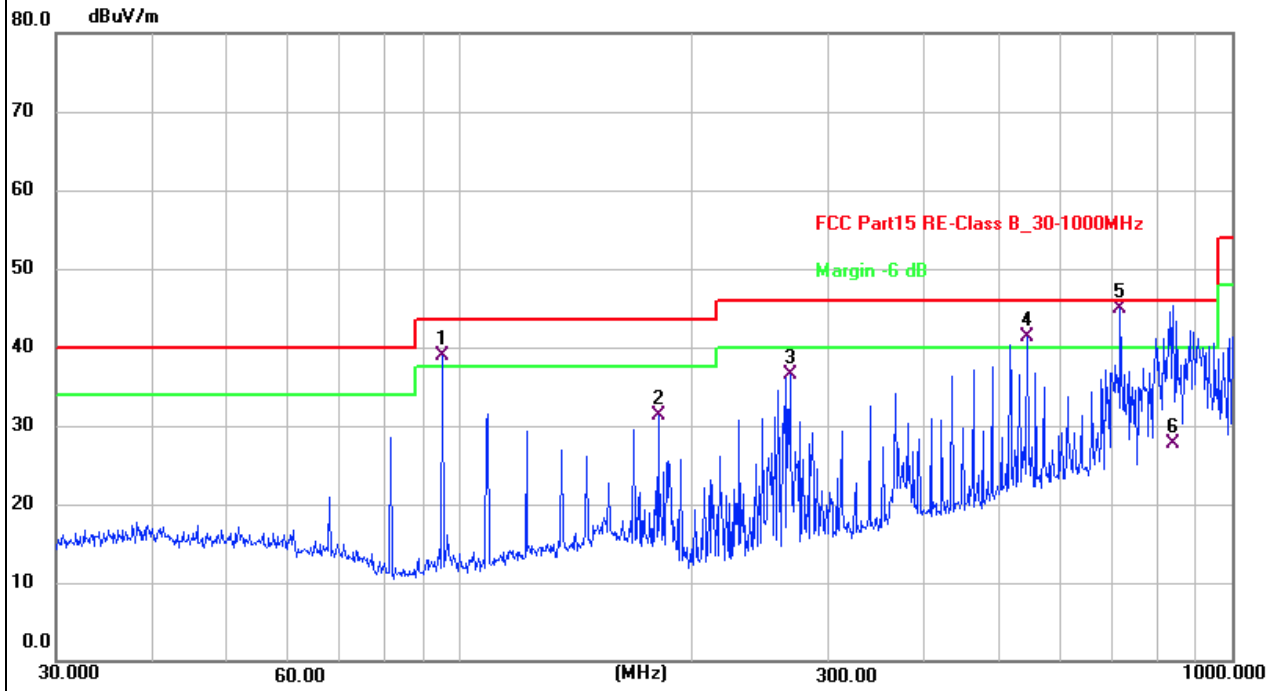

No.	Frequency (MHz)	Reading (dBuV)	Factor (dB/m)	Level (dBuV/m)	Limit (dBuV/m)	Margin (dB)	Detector	Height (cm)	Azimuth (deg.)	P/F	Remark
1 !	94.7601	52.00	-13.09	38.91	43.50	-4.59	QP	100	342	P	
2	180.6488	42.23	-10.83	31.40	43.50	-12.10	QP	100	124	P	
3	267.5455	45.75	-9.33	36.42	46.00	-9.58	QP	100	29	P	
4 !	543.2742	44.25	-2.97	41.28	46.00	-4.72	QP	100	247	P	
5 *	716.6820	44.26	0.72	44.98	46.00	-1.02	QP	100	9	P	
6	841.0868	25.73	2.01	27.74	46.00	-18.26	QP	100	37	P	

Remarks:

1. Measurement Level = Reading level + Correct Factor, Margin = Measurement Level – Limit.
2. The emission levels of other frequencies are very lower than the limit and not show in test report.
3. All test modes were pre-tested, but we only recorded the worst case in this report.

EUT:	SMART LOCK	Model Name:	M6
Test Mode:	TM1	Phase :	Vertical
Test Voltage:	DC 6V from battery		

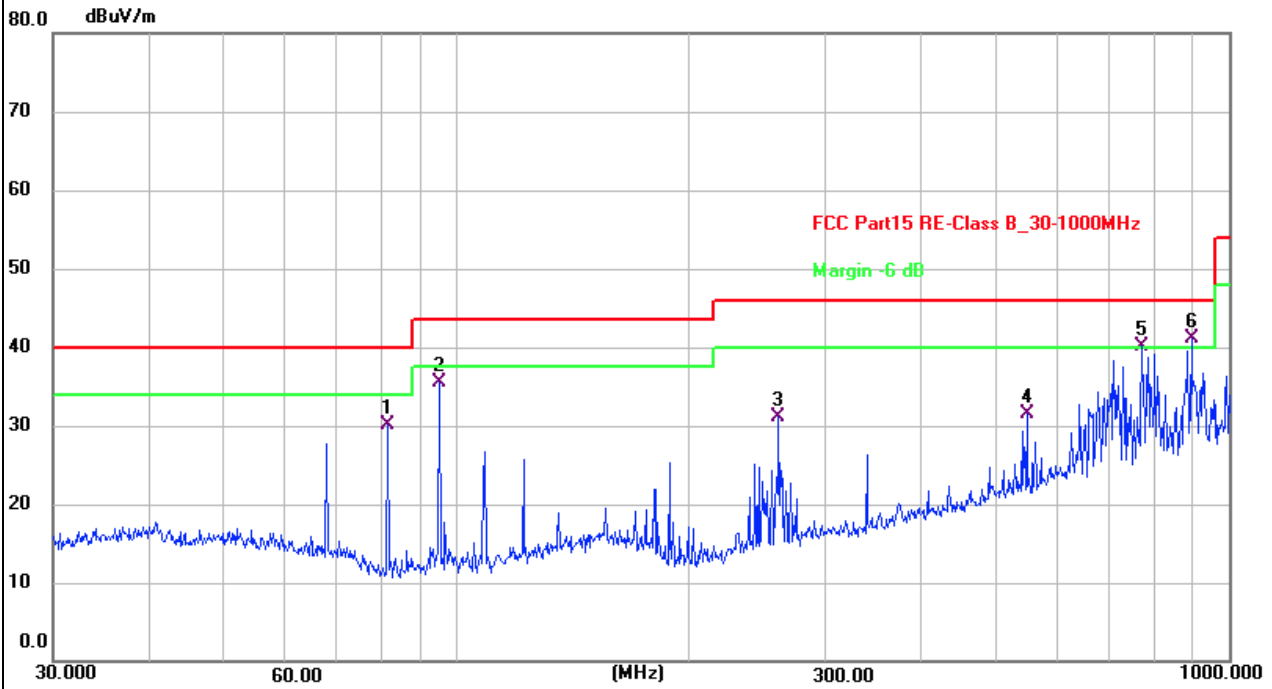

No.	Frequency (MHz)	Reading (dBuV)	Factor (dB/m)	Level (dBuV/m)	Limit (dBuV/m)	Margin (dB)	Detector	Height (cm)	Azimuth (deg.)	P/F	Remark
1	81.2117	43.53	-13.40	30.13	40.00	-9.87	QP	100	192	P	
2	94.7601	48.67	-13.09	35.58	43.50	-7.92	QP	100	192	P	
3	261.0583	40.60	-9.59	31.01	46.00	-14.99	QP	100	267	P	
4	547.0977	34.38	-2.92	31.46	46.00	-14.54	QP	100	84	P	
5 !	771.4486	38.50	1.54	40.04	46.00	-5.96	QP	100	84	P	
6 *	893.8567	37.43	3.61	41.04	46.00	-4.96	QP	100	246	P	

Remarks:

1. Measurement Level = Reading level + Correct Factor, Margin = Measurement Level – Limit.
2. The emission levels of other frequencies are very lower than the limit and not show in test report.
3. All test modes were pre-tested, but we only recorded the worst case in this report.

5.4 Out of Band Emissions

5.4.1 Limits

According to FCC 15.225 (b) Within the bands 13.410–13.553 MHz and 13.567–13.710 MHz, the field strength of any emissions shall not exceed 334 microvolts/meter at 30 meters.

According to FCC 15.225 (c) Within the bands 13.110–13.410 MHz and 13.710–14.010 MHz the field strength of any emissions shall not exceed 106 microvolts/meter at 30 meters.

5.4.2 Test Procedures

Test is conducting under the description of ANSI C63.10 - 2020 section 6.3 to 6.4.

As the radiation test, set the RBW=10kHz VBW=30kHz, observed the outside band of 13.11MHz to 14.01MHz, than mark the higher-level emission for comparing with the FCC rules.

5.4.3 Test Setup

Radiated Emission Test-Up Frequency Below 30MHz

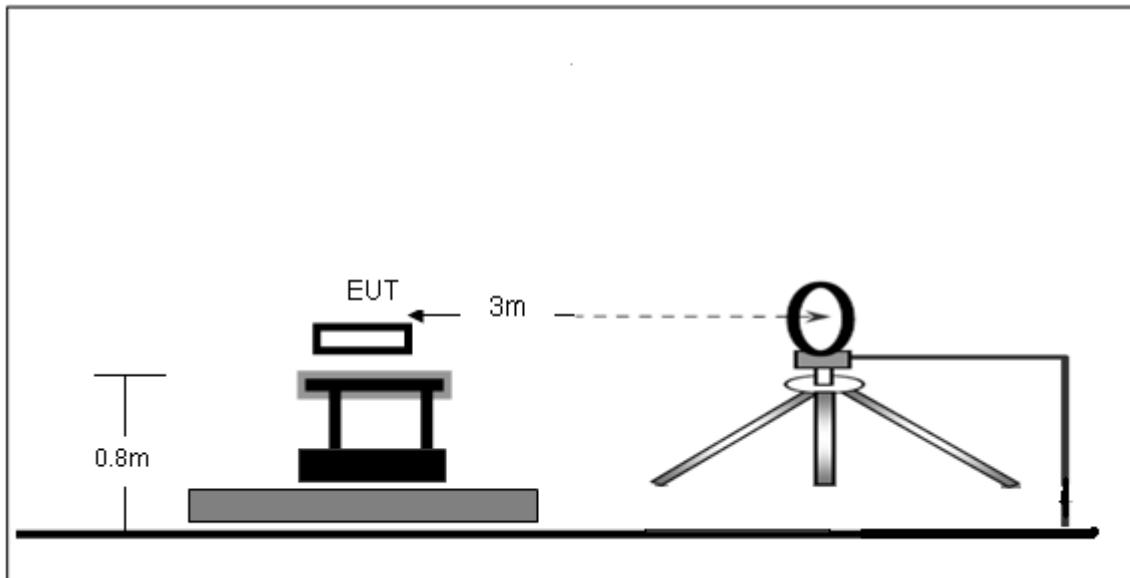

5.4.4 Test Result

EUT:	SMART LOCK	Model Name:	M6
Test Mode:	TM1	Test Voltage:	DC 6V from battery

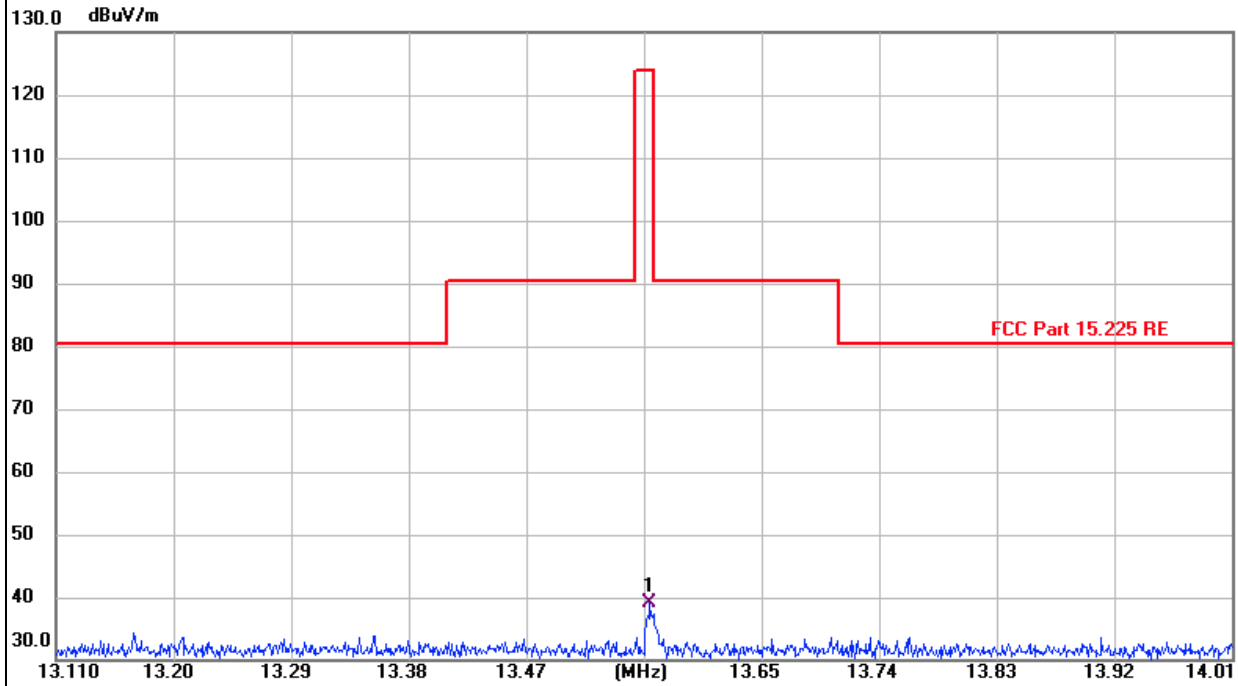

No.	Frequency (MHz)	Reading (dBuV)	Factor (dB/m)	Level (dBuV/m)	Limit (dBuV/m)	Margin (dB)	Detector	Height (cm)	Azimuth (deg.)	P/F	Remark
1 *	13.5645	20.51	18.52	39.03	124.00	-84.97	QP	100	123	P	

Remarks:

1. Measurement Level = Reading level + Correct Factor, Margin = Measurement Level – Limit.
2. The emission levels of other frequencies are very lower than the limit and not show in test report.
3. All test modes were pre-tested, but we only recorded the worst case in this report.

5.5 Frequency Stability

5.5.1 Limits

According to 15.225(e) The frequency tolerance of the carrier signal shall be maintained within $\pm 0.01\%$ of the operating frequency over a temperature variation of -20 degrees to $+50$ degrees C at normal supply voltage, and for a variation in the primary supply voltage from 85% to 115% of the rated supply voltage at a temperature of 20 degrees C. For battery operated equipment, the equipment tests shall be performed using a new battery.

5.5.2 Test Procedures

Test is conducting under the description of ANSI C63.10 - 2020 section 6.8.

5.5.3 Test Result

Reference Frequency: 13.56MHz, Limit: 100ppm			
Temperature (°C)	Power Supplied (VDC)	Frequency Error	
		Error (Hz)	Error (ppm)
50	6	167	12.32
40	6	140	10.32
30	6	125	9.22
20	6	102	7.52
10	6	108	7.96
0	6	121	8.92
-10	6	113	8.33
-20	6	132	9.73

Reference Frequency: 13.56MHz, Limit: 100ppm			
Temperature (°C)	Power Supplied (VDC)	Frequency Error	
		Error (Hz)	Error (ppm)
20	5.1	145	10.69
	6.9	101	7.45

5.6 Occupied Bandwidth

5.6.1 Test method

Use the following spectrum analyzer settings:

Span = approximately 2 to 3 times the 20 dB bandwidth, centered on a hopping channel

RBW \geq 1% of the 20 dB bandwidth

VBW \geq RBW

Sweep = auto

Detector function = peak

Trace = max hold

The EUT should be transmitting at its maximum data rate. Allow the trace to stabilize. Use the marker-to-peak function to set the marker to the peak of the emission. Use the marker-delta function to measure 20 dB down one side of the emission. Reset the marker-delta function, and move the marker to the other side of the emission, until it is (as close as possible to) even with the reference marker level. The marker-delta reading at this point is the 20 dB bandwidth and 99% occupied bandwidth of the emission.

5.6.2 Test result

Phone

Frequency (MHz)	20dB emission bandwidth (kHz)	99% occupied bandwidth (kHz)
13.56	264.7	224.43

Test plots as below:

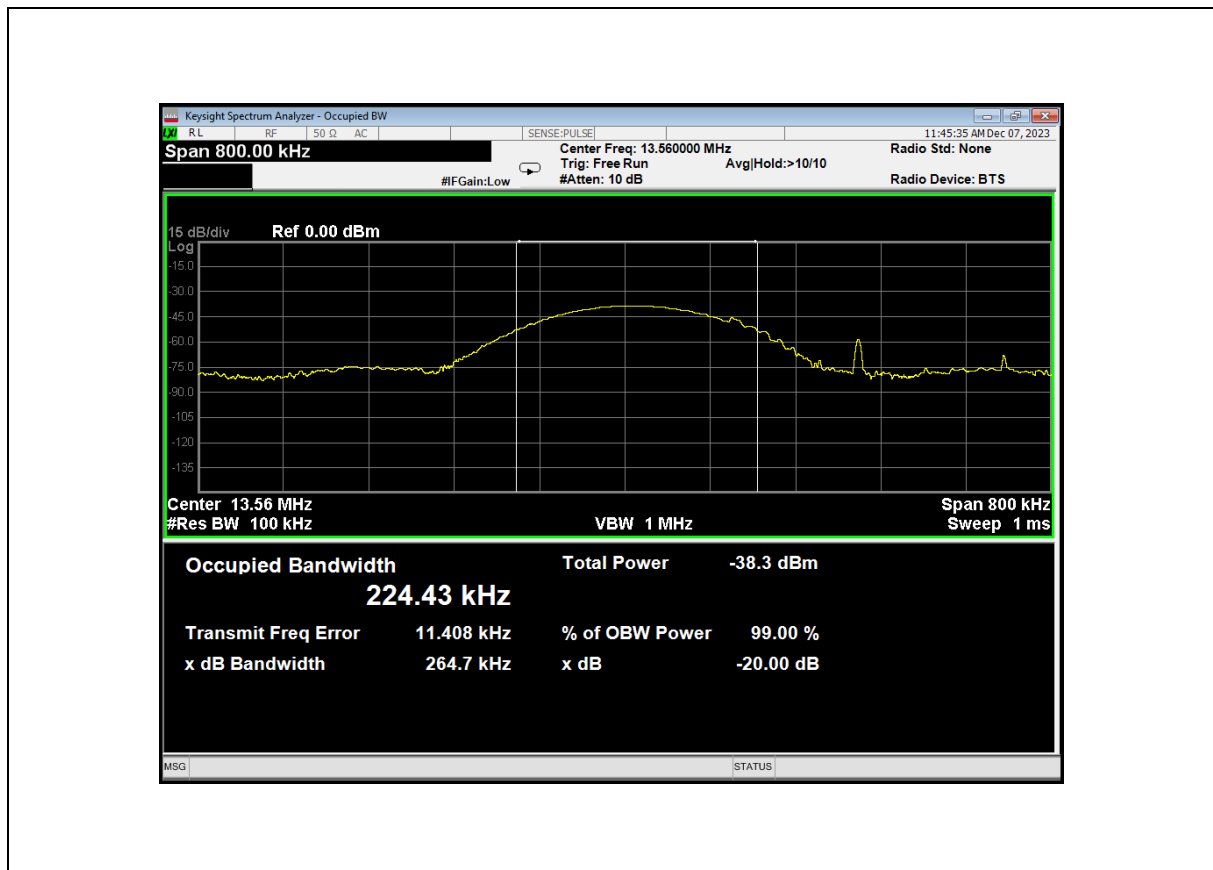

6 Photographs of the Test Setup

Reference to the appendix Test Setup Photos for details.

7 Photographs of the EUT

Reference to the appendix External Photos and Internal Photos for details.

******* END OF REPORT *******