



C6AM SERIES

DC Electric Vehicle Charging Station

Installation and Operation

Manual

ENGLISH

Copyright

XCHARGE reserves all rights to this document the information and topics contained in it. This also applies to any possible claims to copyrights or patents. Forwarding and/or duplicating this document without the expressed permission of XCHARGE is forbidden.

Contents

C6AM SERIES.....	1
Installation and Operation.....	1
Manual	1
Changelog.....	1
Contents.....	3
1. Introduction and Safety Information	1
1.1 Preface.....	1
1.2 Proper Usage	1
1.3 Intended document user	1
1.4 Important safety instructions.....	2
1.5 important signs.....	3
2. Product description.....	5
2.1 System overview.....	5
2.2 Charging plug system	7
3. Technical Data	8
3.1 Nameplate.....	8
3.2 Electrical data	8
3.3 Mechanical Data.....	9
3.4 Environmental data.....	9
3.5 Technical Standards.....	10
3.6 Electrical diagram.....	11
3.7 Function Structure of C6AM	12
3.8 C6AM power curve.....	13
4. Installation	14
4.1 Required space for placing and maintaining.....	14
4.2 Installation environment.....	15

4.3 Construct Foundation.....	15
4.3.1 Concrete Foundation.....	15
4.3.2 Stainless Steel Frame	16
4.4 Power supply and power cable	18
4.5 Packaging and Unpacking	19
4.5.1 Packaging	19
4.5.2 Unpacking	20
4.6 Positioning and wiring	20
4.7 Verification of measurement values.....	24
5. Commissioning and operation	25
5.1 Power up.....	25
5.2 Display and usage	25
5.2.1 Home page.....	25
5.2.2 Control panel	26
5.3 Charging process	26
5.4 Indicator lights	29
6. Fault diagnosis.....	30
7. Maintenance	33
7.1 Cleaning of the cabinet	33
7.2 Anti-dust net replacement	34
8. Contact Information	35

1. Introduction and Safety Information

1.1 Preface

This manual describes the features and functions as well as installation, operation, and maintenance of the XCHARGE C6AM Fast Charging station.

Due to the variance in technical and customer requirements, there are differences which may reflect in the maximum output power, the installed cables, plugs, and display. The components shown in this guide are all example graphics. The illustrations and explanations refer to a typical version of the device. The design of your device may differ from the description in this manual. Please read this document carefully. The C6AM series product complies with UL 2202 and CSA107.1 standards.

1.2 Proper Usage

This product is a high-power charging station for recharging electric vehicles (EVs) using the fixed cable- and plug-connections CCS Combo 1 and CHAdeMO connector, or two CCS Combo 1 connectors.

When any loss or damage occurs due to improper use or unauthorized modification of the product, XCHARGE shall not be liable for the product, the purchaser or third parties. The same is also valid if the guidelines for maintenance provided by XCHARGE are not strictly complied with.

The installation requires a planning with care and should only be carried out by qualified personnel (electricians).

1.3 Intended Document User

This document is intended for:

- Customers who purchased a C6AM, or are in the process of ordering and want to know in more detail about installation and maintenance.
- Contractors who are responsible for site preparation and/or installation of a C6AM
- Contractors who, as a qualified electrician, perform the installation, commissioning, maintenance, or repair of the XCHARGE C6AM fast charging station.
- Requirements for the electrician:
 - Knowledge of the relevant safety and accident prevention regulations
 - Knowledge of NFPA regulations
 - knowledge of national regulations
 - Ability to recognize risks and avoid dangers

1.4 Important Safety Instructions

WARNING

(Safety instructions on a risk with medium risk level! Failure to comply can result in death or serious injury)

1. Please confirm the voltage and current level before installation.
2. The entire installation process needs to be conducted by qualified personnel.
3. Please do not operate in the cloudy, rainy weather or similar conditions may causing possible leakage.
4. DC charging station must be grounded properly.
5. Do not install or use the charging station closed to flammable, explosive materials, or steam.
6. Without qualified personnel, do not try to open, disassemble, or modify the charging station.
7. The use of charging stations may affect or damage some medical or implantable electronic equipment, such as cardiac defibrillators, pacemakers, etc.

ATTENTION

(Safety instructions on a risk with a low degree of risk! Non-compliance can lead to minor to moderate injury)

1. Please use this product in cool and ventilated environment.
2. Before installing or cleaning the charging station, power supply must be shut down.
3. Please use the charging station within the parameters range addressed in the specifications section.
4. Do not use the charging station with non-charging purpose or others non supporting CCS or CHAdeMO charging standard vehicles.
5. If defects are found, such as cracking, wear, inoperable parts, or other damage, stop using the charging station immediately and call the customer service.
6. Do not use the charging station when exposed to heavy rain, thunder, heavy snow, or other severe weather conditions as this may cause damage to station and personal property.
7. Please be careful when transporting the charging station. Avoid strong external shocks. Do not drag, twist, or step on the charging station to prevent damage to any parts. At any time, avoid and prevent damage to the charging station from moisture, liquids, and foreign objects. Do not use if water is present or station is suspected of being damaged or corrosive. Do not touch the charging station, charging cable and charging plug with wires, tools, or other sharp objects.
8. If EV is covered by external protection hood, do not use charging station.
9. Do not start and drive your EV when socket is still connected. The user is responsible for the damage to the EV and charging station caused by improper use of charging station.

1.5 Important Signs

According to ISO7010 and other similar standards, the operating, warning, and prohibition signs below are stucked on the C6AM and are also used in the manual.

These signs below are also used on the nameplate of C6AM:





Warning Signs	Description
	<p>Grounding</p> <p>Connect to a grounding terminal</p>
	<p>General Warning Sign</p> <p>identify a hazard which could result in damage to the operator, machinery, other equipment and / or pollution</p>
	<p>Electricity Hazard</p> <p>Warning of electrical voltage</p>
	<p>Crushing of Hands</p> <p>Touching the device may result in hand injury</p>
	<p>No access for people with active implanted cardiac devices</p>

Figure 1.5.1 Warning signs



Signs	Description
	<p>Note documentation</p> <p>Note all documentation, which are supplied with the product.</p>
	<p>WEEE Symbol</p> <p>Do not dispose of the product with domestic waste. Please follow the valid disposal regulations in the installation site for electronic waste.</p>

Figure 1.5.2 Signs on nameplate

“CAUTION: Have defective cords or wires replaced immediately by a qualified service person.”
 WARNING: DO NOT USE THIS EQUIPMENT IF DAMAGED.

“WARNING: This equipment is intended only for charging vehicles not requiring ventilation during charging.”

THIS EQUIPMENT EMPLOYS PARTS, SUCH AS SWITCHES AND RELAYS, THAT TEND TO PRODUCE ARCS OR SPARKS AND THEREFORE, IF USED IN A GARAGE, LOCATE IN A ROOM OR ENCLOSURE PROVIDED FOR THE PURPOSE OR NOT LESS THAN 50mm ABOVE THE FLOOR.

FOR USE WITH ELECTRIC VEHICLES.

WARNING: DO NOT USE EQUIPMENT WHERE EXPOSED TO FLAMMABLE VAPOURS.

2. Product Description

2.1 System Overview

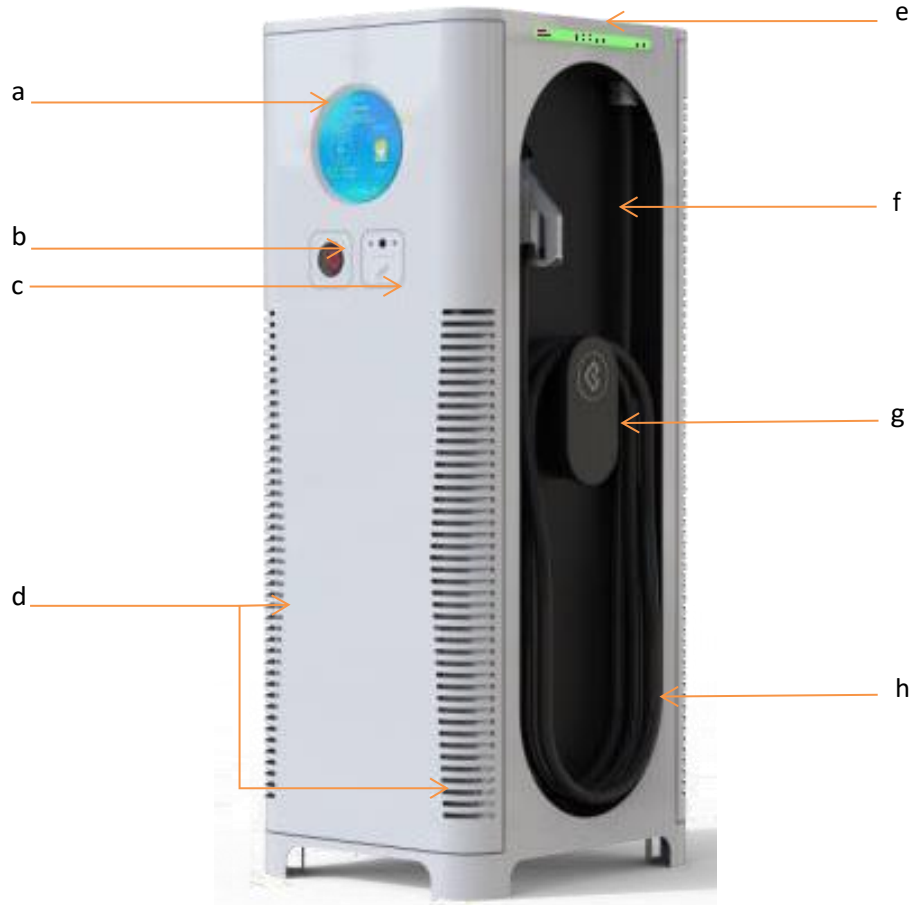

Figure 2.1.1

a	HD/Touch screen with 22.5 cm diameter (HMI)	e	LED Indicator
b	Emergency button	f	Charging plug
c	Control panel with RFID/Credit card reader	g	Cable holder
d	Air inlet	h	Air outlet

Table 2.1.1 Housing and elements outside

This manual is valid for all the C6AM Versions, which are shown below in Table 2.1.2.

Type	Max. output power	Max. input DC current	Power module (30kW)	CCS Combo 1 plug	CHAdEMO plug
C6AM-150-JC(208V)	95kW	300A	5	200Ax1	125Ax1
C6AM-150-JC(480V)	150kW	200A	5	200Ax1	125Ax1
C6AM-150-CC(208V)	95kW	300A	5	200Ax1	NA
C6AM-150-CC(480V)	150kW	200A	5	200Ax2	NA

Table 2.1.2 Type of C6AM

Notes:

- All the double-plug versions intelligently distribute power between the two charging ports: the whole output power of charger is distributed over two plugs evenly (half) or by one plug at the proper charging voltage level. For each side the output current can also be limited as requested.
- User can recognize the different types of C6AM through the first eight letters in its SN number, for example in SN number “C6AM15JC22NHEVYPFY” the type is C6AM-150, up to 95 output with CCS 1 and CHAdEMO plug;
- Touch or non-touch screen is optional for all these kinds of C6AM.



Figure 2.1.2 Design sketch of construction for C6AM

2.2 Charging Plug System

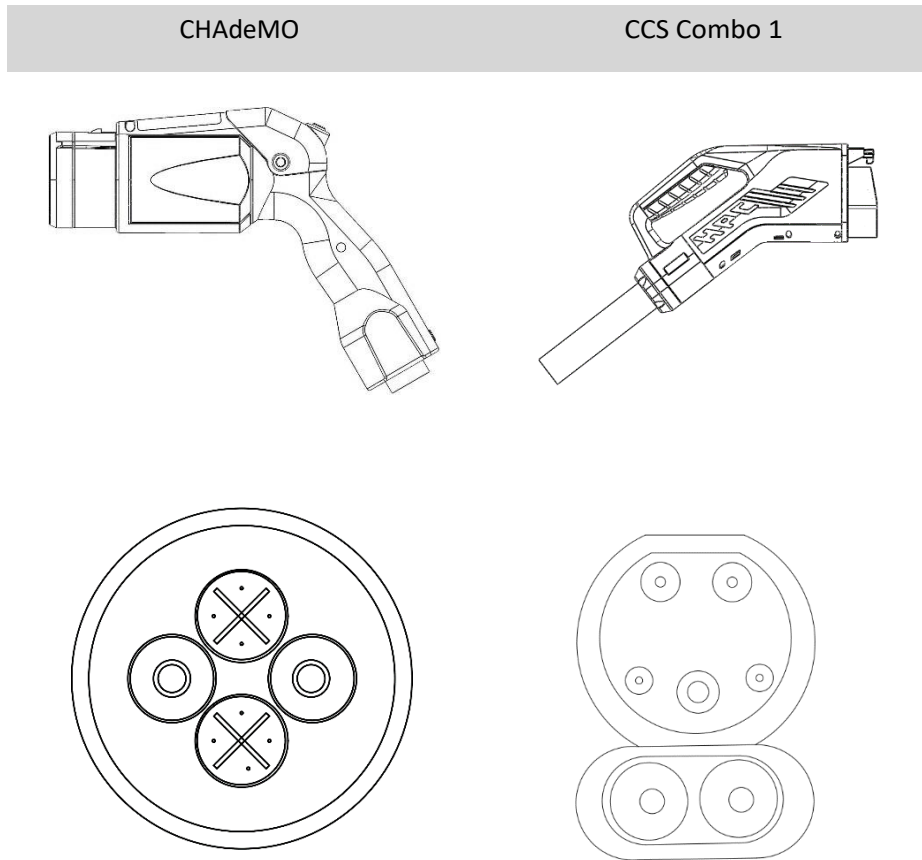

Figure 2.2 Structure of charging plug, CHAdeMO and CCS Combo 1

3. Technical Data

3.1 Nameplate

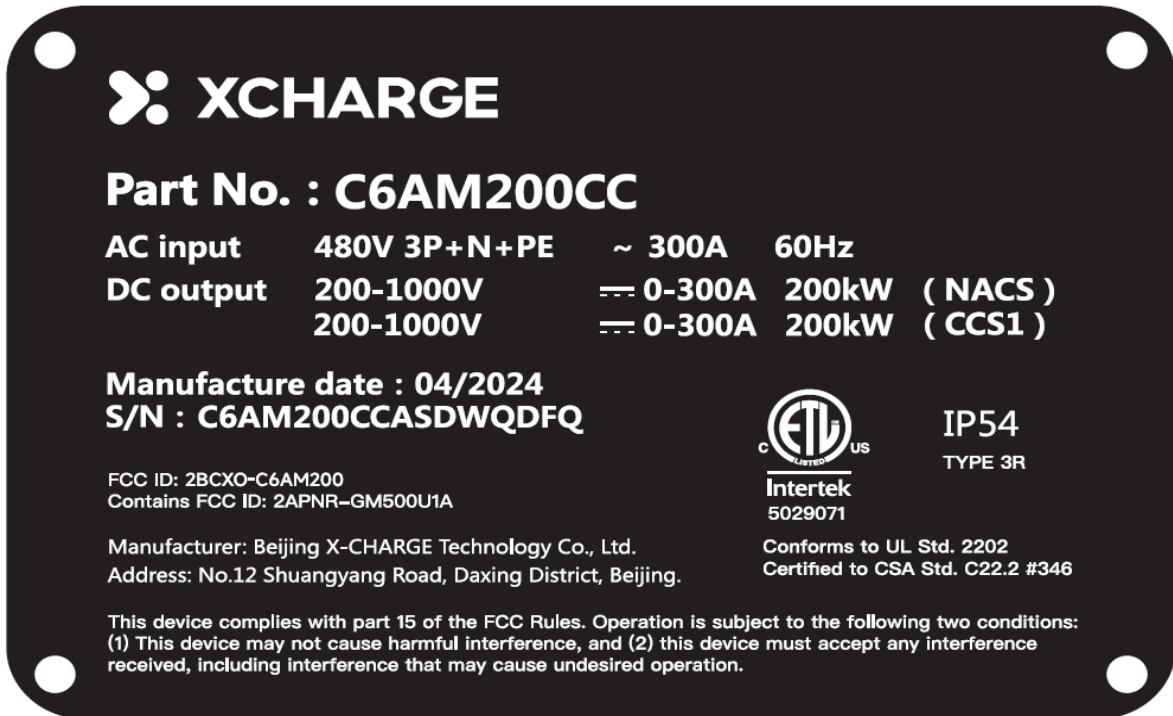

Figure3.1.1 Nameplate (for reference only)

Nameplate contains all the necessary information includes:

- Product type and serial number
- Input power and wiring
- DC rated output voltage, current and power
- Manufacturing date

3.2 Electrical Data

Input	
Input voltage range	3 phase 208 V _{AC} +/- 10% 60 Hz 3 phase 480 V _{AC} +/- 10% 60 Hz
Power factor	> 99% at nominal output power
Efficiency	95% at nominal output power

DC output (C)	
Maximum output power	208 V _{AC} :95kw 480 V _{AC} :150 kw

Output voltage range	200 – 1000 V _{DC} (Combo-1)
Maximum output current	200 A _{DC} continuously (Combo-1)
Harmonic component	5% < in 50 – 100% of rated output power
DC output (J)	
Maximum output power	60 kW
Output voltage range	200 – 500 V _{DC} (CHAdeMO)
Maximum output current	125 A _{DC} (CHAdeMO)
Harmonic component	5% < in 50 – 100% of rated output power
General	
DC connection standard	SAE J1772, UL2251 Combo1 CHAdeMO 1.0
DC cable length	3.5/5/7 meters
DC plug type	COMBO-1 / CHAdeMO
RFID system	ISO 14443 A&B/ISO 15693/ ISO18092/ECMA-340

Table 3.2.1

3.3 Mechanical Data

Mechanical data	
Dimensions (H x W x D)	1750 mm x 615 mm x 740 mm
Weight	325 (60 kW) - 395 kg (150 kW)
Volume	0.75m ³
Dimensions including packaging	2100 mm x 850 mm x 900 mm
Weight including packaging	375 (60 kW) - 450 kg (150 kW)
Weight concrete foundation	Min. 450 kg
Mechanical impact protection	IK10

Table 3.3.1

3.4 Environmental Data

Environmental data	
Ground load bearing	At least 450kg

Ingression protection	IP54
Temperature range – Operation	-20 °C to +50 °C
Temperature range – De-rating	+50 °C to +70 °C
Temperature range - Storage	-40 °C to +80 °C
Operating Relative Humidity	5%-95%, no condensing on the surface
Storage Relative Humidity	95%, no condensing on the surface
Humidity	Up to 95% no condensation on the surface
Operational noise level	<65 dB in rated output power
Atmospheric Pressure	79KPa-106KPa
Altitude	2000 m max.
Network	GSM/WCDMA/LTE/LAN

Table 3.4.1

3.5 Technical Standards

The C6AM products were already approved by TÜV Rheinland according to the technical standards below:

Healthy, safety and general requirements	EN 50385: 2017 EN 61851-1: 2011 EN 61851-23:2014 EN 61851-24:2014
EMC	IEC 61851-21:2018 EN 301 489-1 V2.2.0 (2017-03) EN 301 489-3 V2.1.1 (2017-03) EN 301 489-52 V1.1.0 (2016-11)
Radio	EN 300 330 V2.1.1 (2017-02) EN 301 511 V12.5.1 (2017-03) EN 301 980-1 V11.1.1 (2016-07) EN 301 980-2 V11.1.2 (2017-08)

Table 3.5.1

3.6 Electrical Diagram

Circuit diagram:

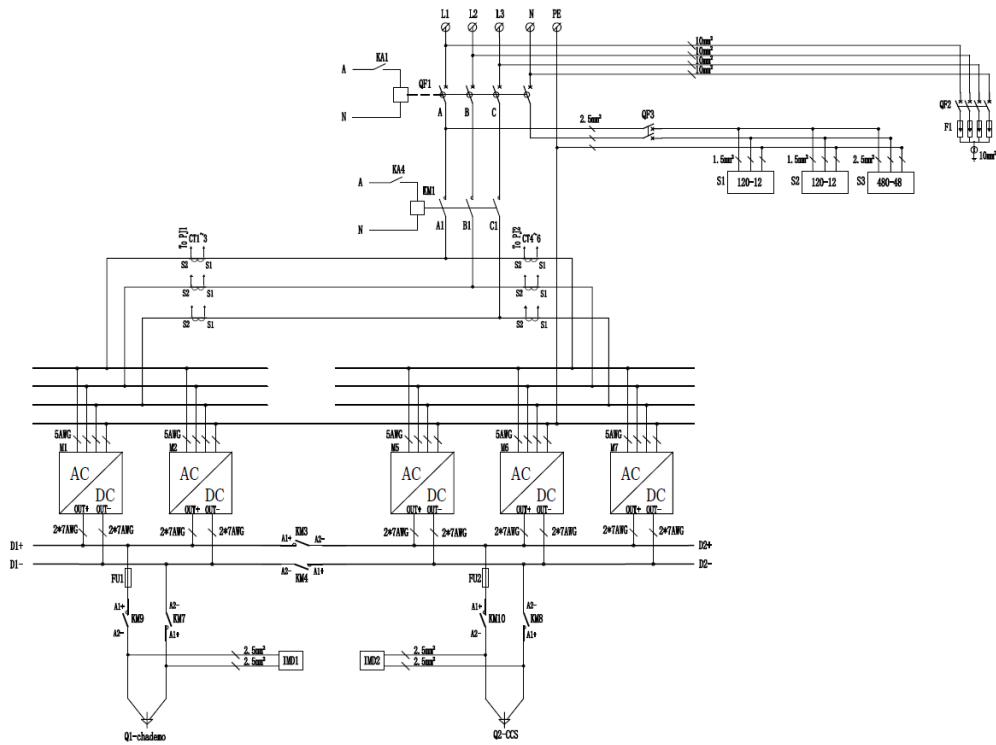

Figure 3.6.1 Electrical connection diagram

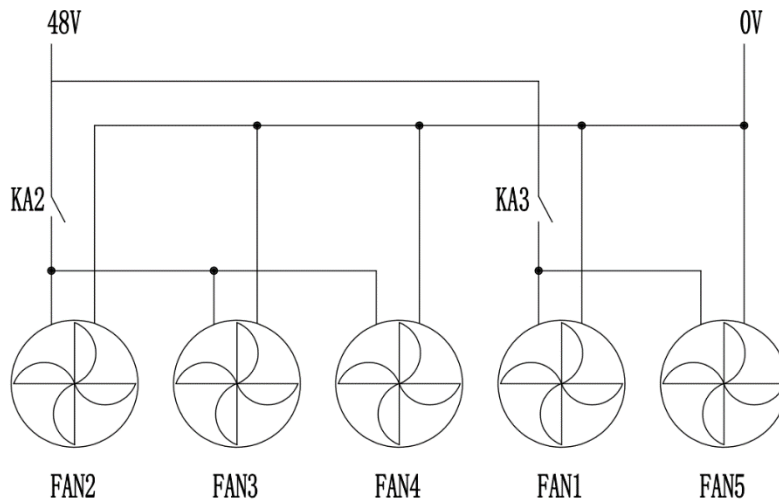

Figure 3.6.2 Fans' control diagram

Notes:

The diagram was already approved by TÜV Rheinland according to Standard EN 61851-23. For different types of C6AM the size of cable in the electrical connection diagram is variable.

3.7 Function Structure of C6AM

The Figure 3.7.1 below introduces the structure of C6AM from basic to sophisticated functions

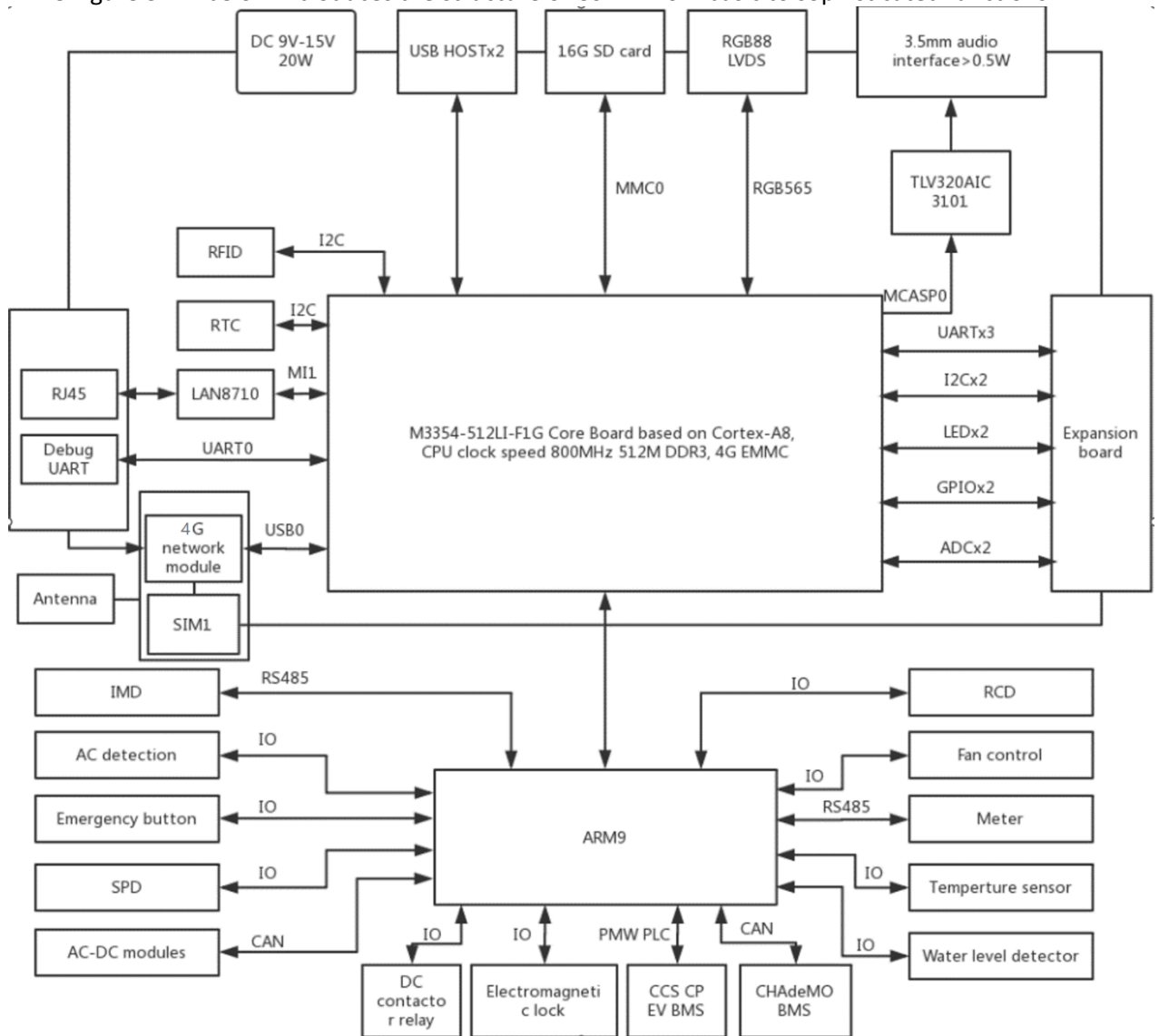

Figure 3.7.1

3.8 C6AM Output Power vs Temperature Curve

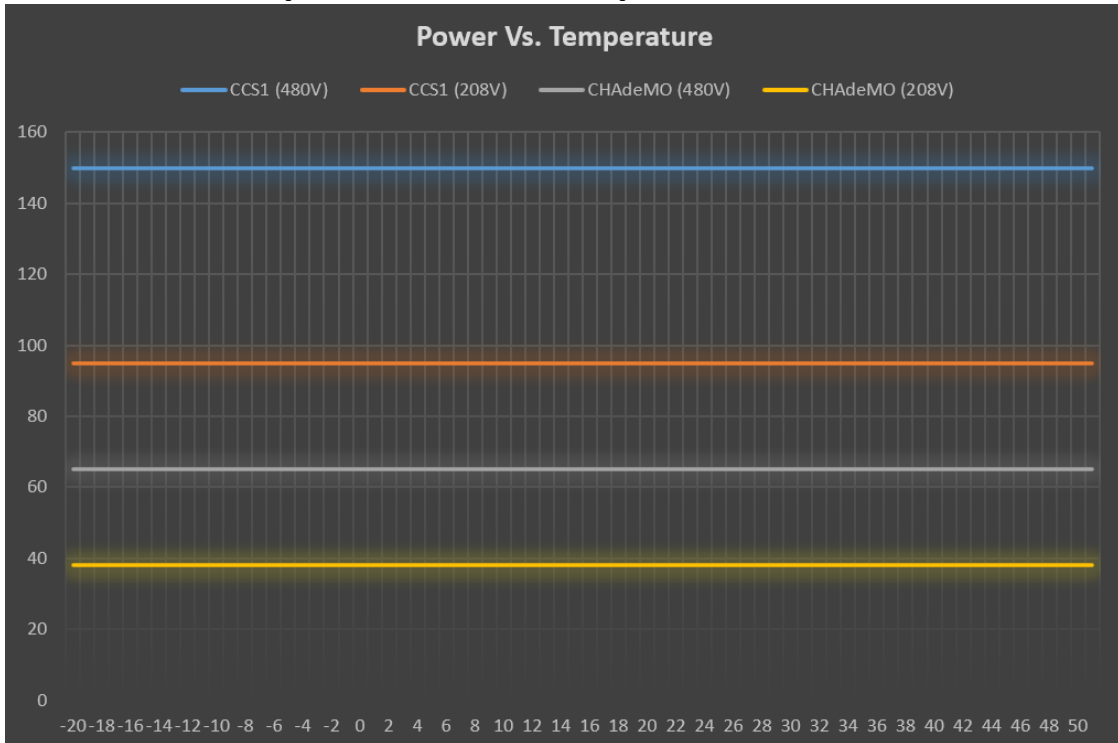
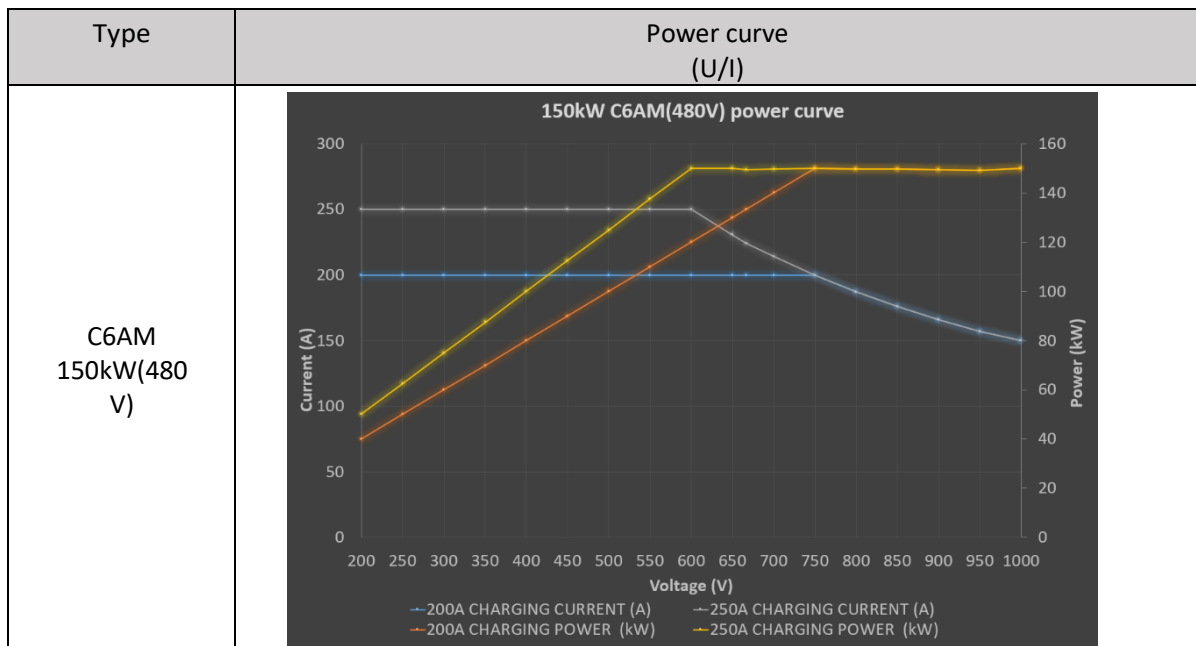

Figure 3.8

3.9 C6AM Power Curve



<p>C6AM 60Kw(208V)</p>	<p>60kW C6AM(208V) power curve</p> <p>This graph plots Current (A) on the left y-axis (0 to 300) and Power (kW) on the right y-axis (0 to 70) against Voltage (V) on the x-axis (200 to 1000). It shows four data series: 200A Charging Current (A) (blue line), 250A Charging Current (A) (grey line), 200A Charging Power (kW) (orange line), and 250A Charging Power (kW) (yellow line). The 200A current is constant at 200A until 300V, then decreases. The 250A current is constant at 250A until 300V, then decreases. The 200A power increases from ~45kW at 200V to ~60kW at 300V and remains constant. The 250A power increases from ~40kW at 200V to ~60kW at 300V and remains constant.</p>
<p>C6AM 95kw(208V)</p>	<p>95kW C6AM (208V) power curve</p> <p>This graph plots Current (A) on the left y-axis (0 to 300) and Power (kW) on the right y-axis (0 to 100) against Voltage (V) on the x-axis (200 to 1000). It shows four data series: 250A Charging Current (A) (blue line), 200A Charging Current (A) (grey line), 250A Charging Power (kW) (orange line), and 200A Charging Power (kW) (yellow line). The 250A current is constant at 250A until 400V, then decreases. The 200A current is constant at 200A until 400V, then decreases. The 250A power increases from ~45kW at 200V to ~95kW at 400V and remains constant. The 200A power increases from ~40kW at 200V to ~95kW at 400V and remains constant.</p>

Table 3.8.1

4. Installation

The product will be delivered to a warehouse by logistic company and handed over to the customer. Normally XCHARGE is not responsible for the transport of charger and delivery to final installation location.

4.1 Required Space for Placing and Maintaining

The space that C6AM needs is calculated as follows:

- Vertical view: 740 mm x 615mm
- Front and backside 0.8 meter to open the front door.
- Right and left 1.0 meter to facilitate maintenance personnel to replace the plug cable.

As shown in the picture, it is the construction area.

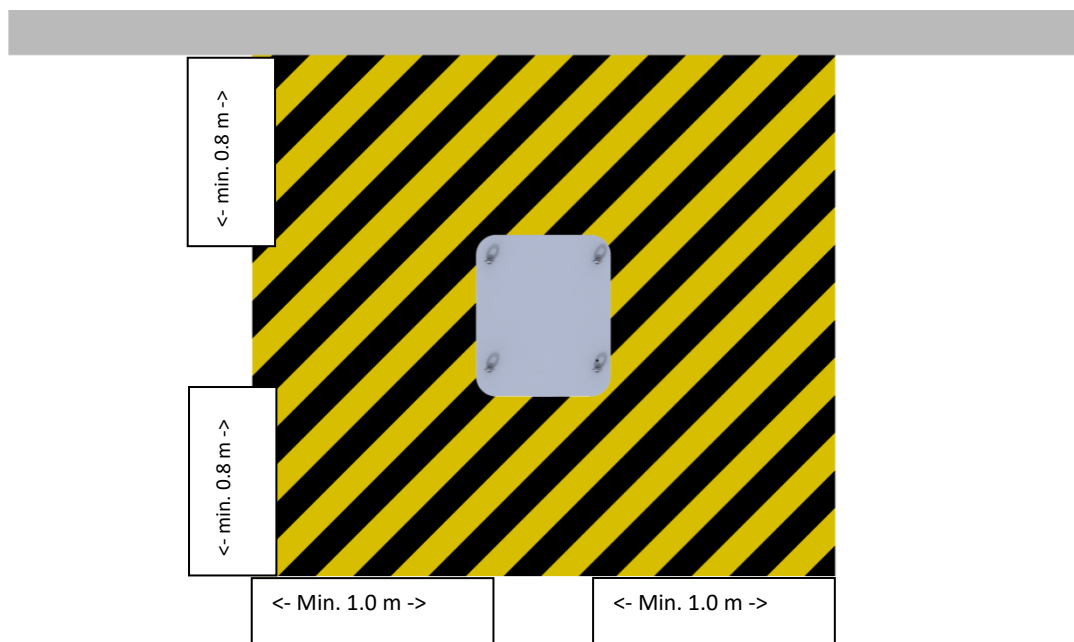

Figure 4.1

4.2 Installation Environment

The installation shall not be made in a commercial garage (repair facility) or closer than 20 feet (508 mm) of an outdoor motor fuel dispensing device.

WARNING

Danger of life through improper installation!

Ignoring the environmental conditions can lead to dangerous situations when dealing with electricity.

- When installing the charging device outside, avoid direct sunlight of the display, which will impact the ability to scan code for installation.
- Do not install and use the charging device near flammable, explosive, rough or combustible materials or chemicals or steam.
- The concrete space needs to be able to withstand four times the load.

4.3 Construct Foundation

4.3.1 Concrete Foundation

The C6AM charging station can be built on a concrete foundation. The flat surface of foundation should not be larger than the dimension of 800 mm * 800 mm. For the entrance of the cable, a hole should be provided in the foundation corresponding to the type of power cable, which was dimensioned in Figure 4.3.1 as an example for the C6AM 150kW. If you do not use a Prefabricated foundation, please notice the hardening times of the applied concrete before installation.

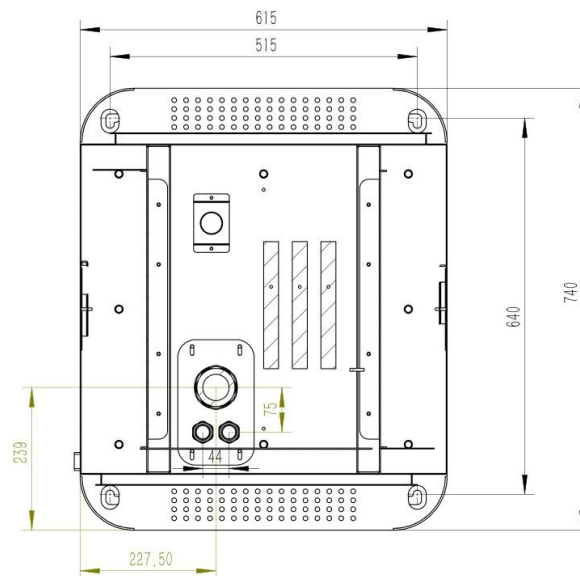

Figure 4.3.1 Concrete foundation for 150kW C6AM

The height of the foundation is determined by the terrain of the site. Depending on rainfall and drainage a height between 15 cm and 30 cm above the ground is recommended by XCHARGE. Because of frost-proof the foundation must be about 80 cm deep under the ground.

Notes:

- laying of power cables should be carried out in accordance with relevant national and industrial standards and specifications including construction quality, process, and technical standards.
- Cable selection specification shall be selected according to the type, power, voltage and current level of the equipment and the number of equipment installed.
- When cables are laid, they are strictly forbidden to be exposed. Cable bridges, line pipes and directly buried cabling should be used based on the environment and installation location.
- When the cables are directly buried, the depth of burying shall not be less than 0.8m because of the frost-proof.
- When plastic pipes are used for power distribution, flame-retardant type, and wall thickness >2.0mm shall be adopted. When a steel pipe is used for underground pipe wiring, the wall thickness is >2.5mm and anticorrosive treatment is carried out.
- The selection of power cable specifications should be selected according to the installation environment and fire requirements.

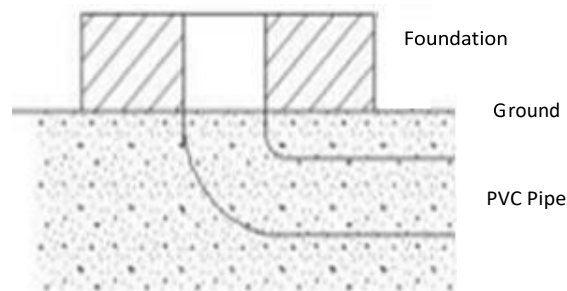

Figure 4.3.2

4.3.2 Optional Stainless Steel Frame

The C6AM charging station can be fixed onto the flat ground with a stainless-steel frame. The ground shall be concrete or at equal level of hardness. Please refer to Figure 4.3.3, Figure 4.3.4, and Figure 4.3.5 for the details of instruction.

Upper side (to be connected to the bottom of charger):

4 x M12 bolts and 4 x M12 weld nuts (provided by XCHARGE)

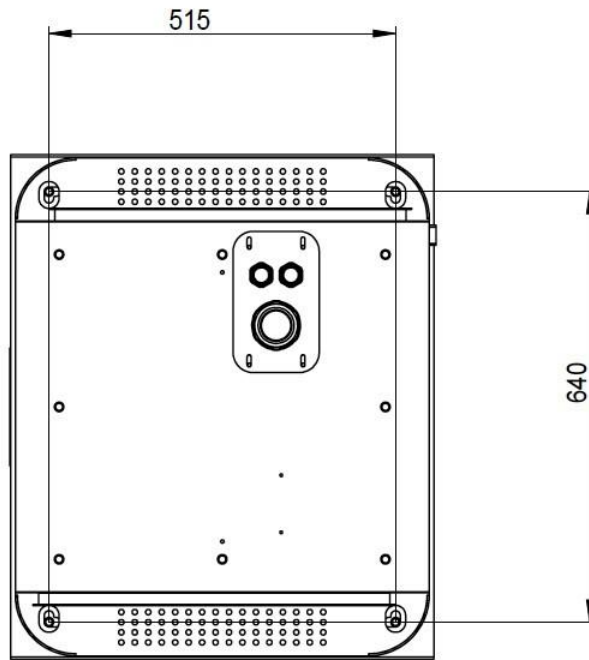

Figure 4.3.3

Bottom side (to be fixed onto the ground):

4 x M12 expansion bolts

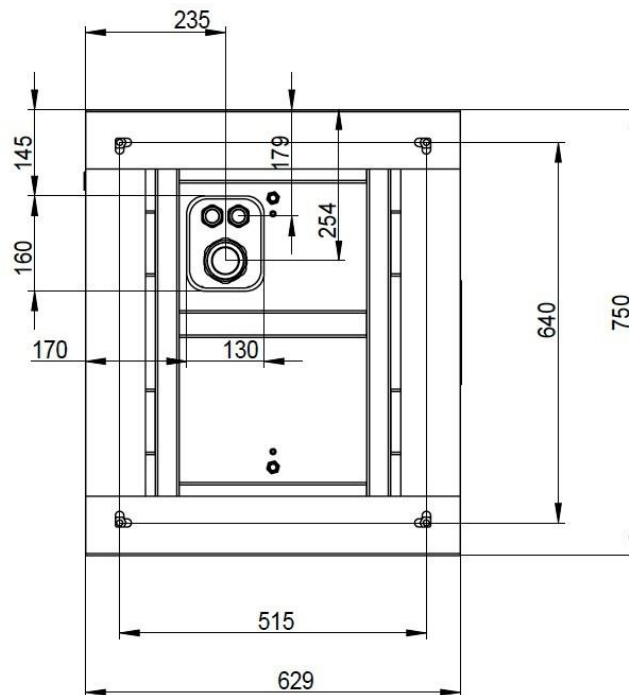

Figure 4.3.4

Left and right sides (3 x removable stainless-steel plates - one with reserved hole):

8 x M6 Philips flat head screws on each side (provided by XCHARGE)

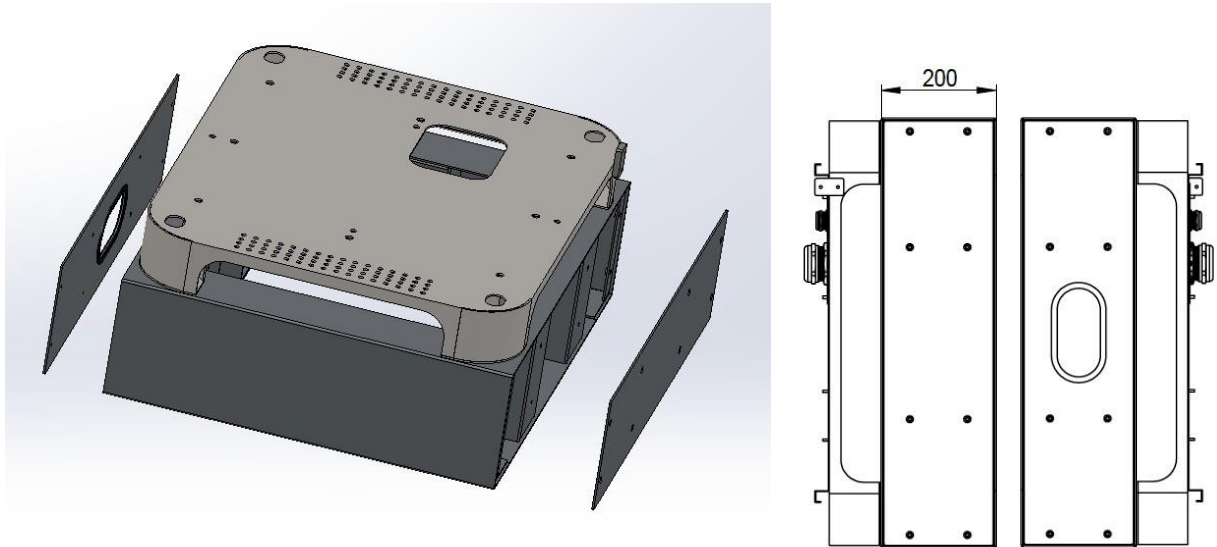

Figure 4.3.5

4.4 Power Supply and Power Cable

- Requirements for the power supply:

Power	Rated voltage	Rated current	Frequency
2 power modules	480V±10%, AC	90A	60Hz
4 power modules	480V±10%, AC	180A	60Hz
5 power modules	480V±10%, AC	225A	60Hz
5 power modules	208V+10% AC	330A	60Hz

Table 4.4.1

- Cable type: 3P+N+PE, shielded cables are optional if required by local law.
- The optional cable shielding must be attached to the PE Rail at both ends of the cable.
- The diameter of the cable conductor must be determined by your contractor / electrician.

Here is the suggestion for the cable dimension of all types C6AM:

Power	Cable dimension	Cable gland (diameter)	Maximum Input Current
2 Power modules(480V)			3P 90A
3 Power modules(480V)			3P 135A
4 Power modules(480V)			3P 180A
5 Power modules(480V)	3x150mm ² 2x70 mm ²	52-60mm	3P 225A
5 Power modules(208V)	3x185mm ² 2x95 mm ²	52-60mm	3P 330A

Table 4.4.2

4.5 Packaging and Unpacking

4.5.1 Packaging

Material	Sizing	Comments
Shrink wrap	1 pack	Prevent scratch
Foam plastic protection	2m x 2m	Prevent shaking
Tilt indicator	2 set	Guarantee upright status
Wooden box	0.85m x 0.9m x 2100m	
Nail gun	1 set	



It is necessary to ensure vertical transportation. If the indicator turns red, it can be considered that during transportation severe impact and tilt occurs.

Figure 4.5.1

4.5.2 Unpacking

Remove the package to confirm that charging station is intact.

- Remove the outer wooden box with a crowbar
- Remove foam plastic protection
- Remove the inner shrink wrap

 **WARNING**

risk of suffocation!

Children are not allowed to play with plastic wrap and shrink wrap.



Figure 4.5.2

4.6 Positioning and Wiring

 **CAUTION**

Material damage due to improper handling

- Collisions and bumps can damage the charging station.
- Move the charging station with the utmost caution.
- Please use a soft pad to set down the charging station.

- Insert the forklift from the bottom facing the plug side (CCS or CHAdeMo) of charging station and move the charging station to the desired installation location. As shown in Figure 4.6.1 the width of fork is up to 420mm and the length of fork is min. 600mm. **Please move the charging station with the utmost caution!**

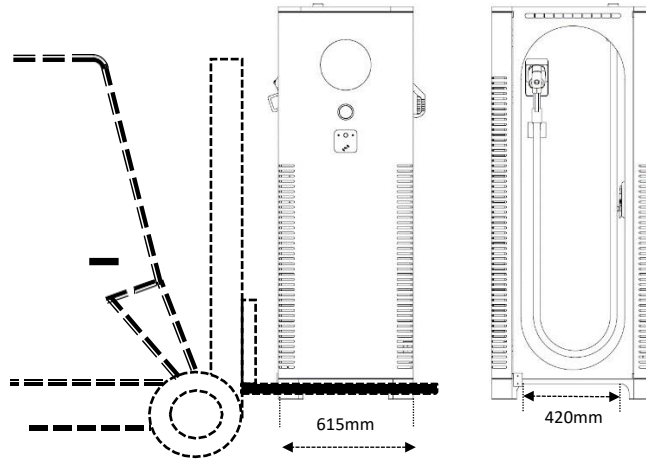

Figure 4.6.1

- The charging station can also be transported and aligned by crane. This can be achieved through four eye-bolts included in delivery, which can be screwed into the tapped holes on the top.

Note:

- Only 60kW and 120kW C6AM are only to be transported by crane for a short distance (for example from floor to Foundation). For 150kW because of the weight, a forklift is suggested by XCHARGE to apply. Please ensure that the body of C6AM stays stable during movement through crane or forklift to avoid the possible swinging, which may cause damage to the charger;
- The cable entrance on the bottom of charger is divided into three inlets, of which the first is for the power cable, the second is for the LAN cable and the third is for the signal cable. In order to prevent animals from entering the charging station to cause unnecessary damage, it should be sealed with a barrier plate and three waterproof cable glands.

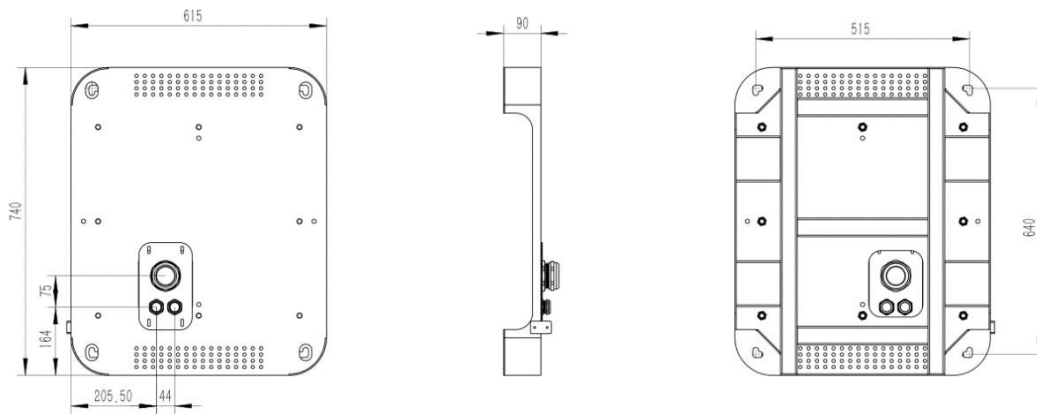

Figure 4.6.2



WARNING

Mortal danger due to electrocution!

Contact with high power parts can result in electric shock, burns or death. Before working, please put on the required protection equipment such as protective clothing and gloves:

- Disconnect the system from the power supply.
- Make sure that the power supply is disconnected before and while working on installation.

- After opening the front door and removing the cover, connect the 3 phase cables L1, L2, L3 and the neutral conductor N as well as the PE protective conductor to the busbar. Then check the connection carefully. Tighten all terminal screws to complete the installation of the power cables. The screw size and torque requirements are shown below in table 4.6.1.

Type	Size of screws	Torque	tools
C6AM 60kW			
C6AM 120kW			
C6AM 150kW(480V)	L1/L2/L3/N M10x20mm PE M8x16mm	M8: 15-20N.m M10: 25-30N.m	13mm socket for M8; 17mm socket for M10
C6AM 95kW(208V)	L1/L2/L3/N M10x20mm PE M8x16mm	M8: 15-20N.m M10: 25-30N.m	13mm socket for M8; 17mm socket for M10

Table 4.6.1

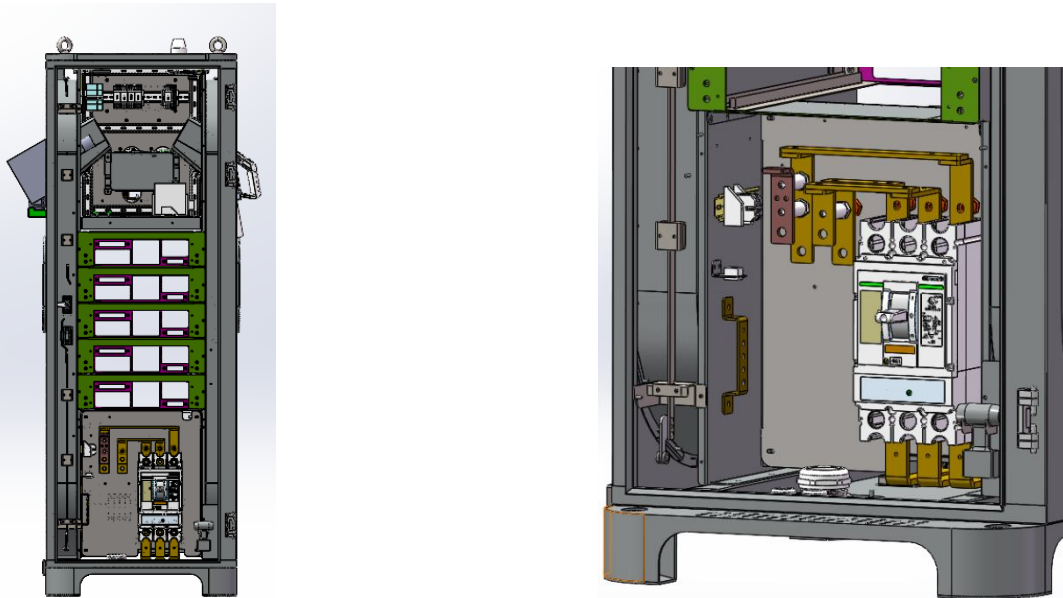

Figure 4.6.3

- In case that the station will be connected with a LAN cable for the backend connection, this cable should be laid through waterproof gland on the bottom to the RJ45 Port on the A8 communication board, shown in Figure 4.6.4. (it's suggested to use such soft flat LAN cable like in figure because of the limited place for installation. Any other RJ45 converter in the charger could be installed by customer if needed)
- In case that the station connects with backend through SIM card, the SIM card slot shown in Figure 4.6.4 can be used. (only for standard SIM card size 15x25mm)

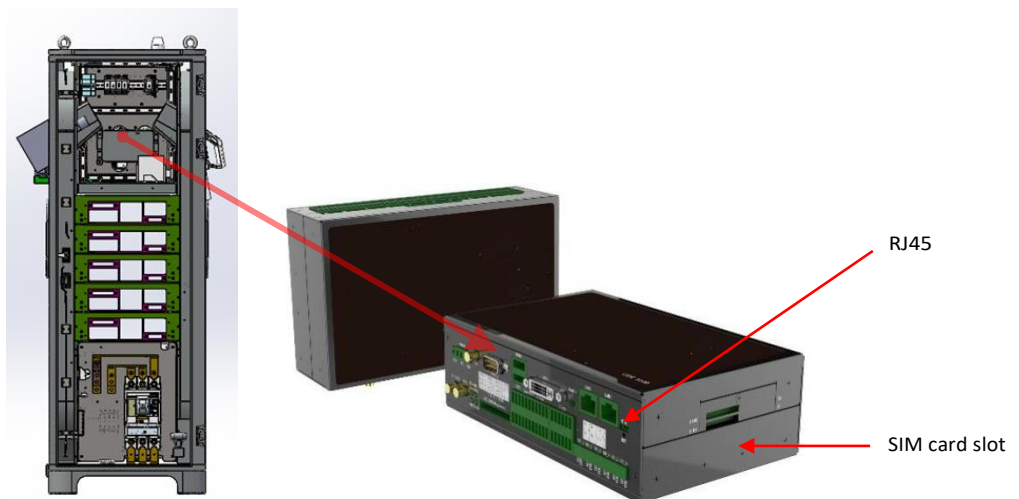

Figure 4.6.4

- After installing the cable into the charging station, the bottom of the charging station is fixed to the concrete platform by 4 fixed concrete anchor screws M10.

4.7 Verification of Measurement Values

Please ensure all measured values are within specified range before proceeding to

commissioning and operation.

Measurement in 480Vac

Measurement points on live side	Unit	Nominal value	Specified range
L1 to N	Voltage	277 V	± 10%
L2 to N	Voltage	277 V	± 10%
L3 to N	Voltage	277 V	± 10%
L1 to L2	Voltage	480 V	± 10%
L1 to L3	Voltage	480 V	± 10%
L2 to L3	Voltage	480 V	± 10%
N to PE (on connection terminal)	Voltage	0 V	
PE to N (on connection terminal)	Resistance	<1000m Ω in TN-S system	variable according local law/standards and different earthing system

Table 4.7.1

Measurement in 208Vac

Measurement points on live side	Unit	Nominal value	Specified range
L1 to N	Voltage	120 V	± 10%
L2 to N	Voltage	120 V	± 10%
L3 to N	Voltage	120 V	± 10%
L1 to L2	Voltage	208 V	± 10%
L1 to L3	Voltage	208 V	± 10%
L2 to L3	Voltage	208 V	± 10%
N to PE (on connection terminal)	Voltage	0 V	
PE to N (on connection terminal)	Resistance	<1000m Ω in TN-S system	variable according local law/standards and different earthing system

Table 4.7.2

5. Commissioning and Operation

5.1 Power Up

 WARNING
Mortal danger due to electrocution! Contact with high power parts can result in electric shock, burns or death.

If the charger is firmly fixed on the foundation and the power supply has been properly applied, then the charging station can be powered up by turning on the main switch, which is located on the bottom left behind the front door.

Once the charger has been powered on, the charger operates automatically, and loads the operating system, ready to use in about two minutes.

5.2 Display and Usage

5.2.1 Home Page

This is the home page on screen after the charger is powered up.

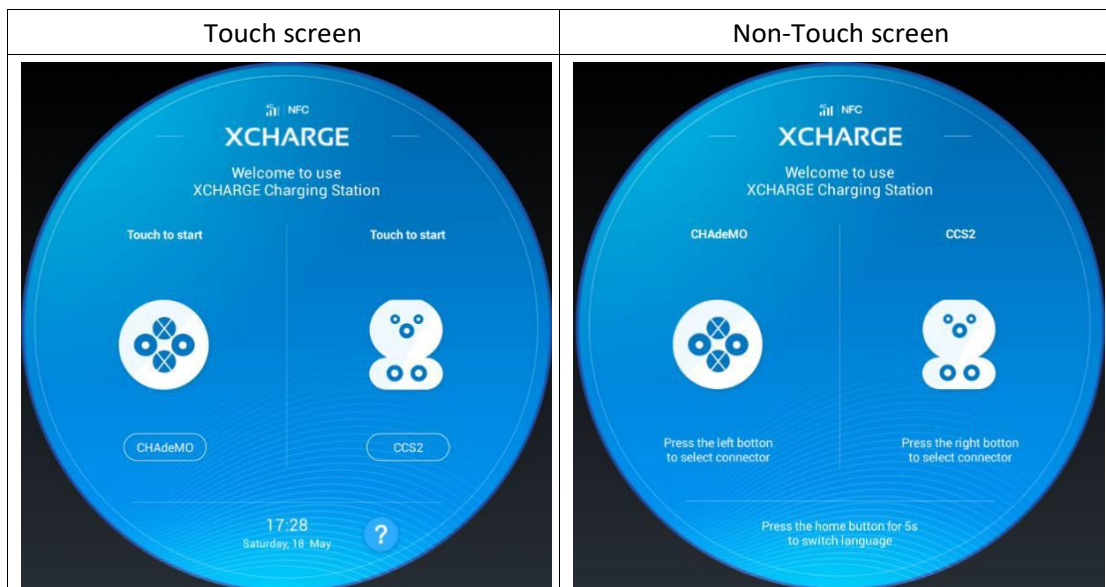

Figure 5.2.1 Start page for touch and non-Touch screen

5.2.2 Control Panel

For the charger with non-touch screen please press the arrow buttons and home button based on the guides on display to choose the options on screen.

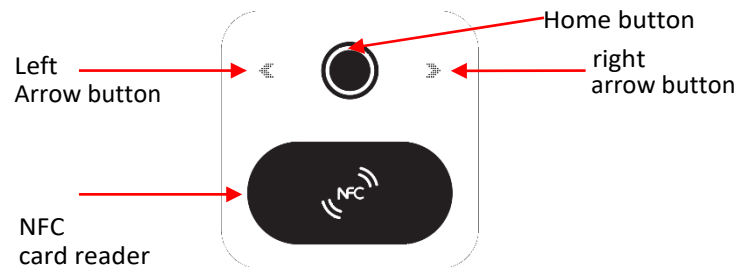

Figure 5.2.2 Control panel

! WARNING

Danger of life through wrong installation!

Extension cables are not permitted according to IEC 61851-1. If an extension cable or a second cable set is used, there is a risk of electric shock or cable fire.

5.3 Charging Process

The charging flow chart for C6AM with touch Screen:

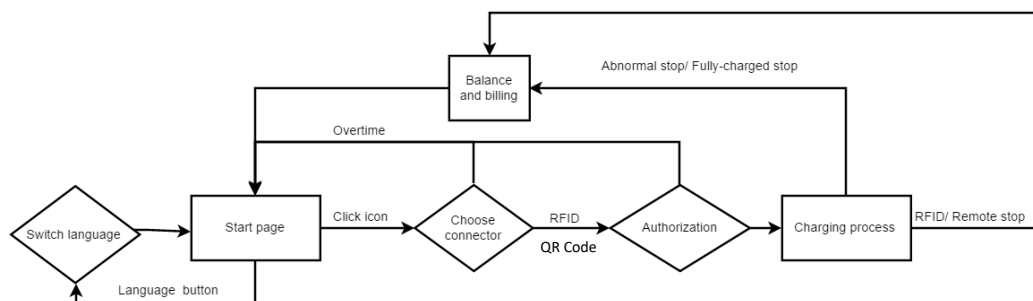

Figure 5.3.1

The charging flow chart for C6AM with Non-Touch Screen:

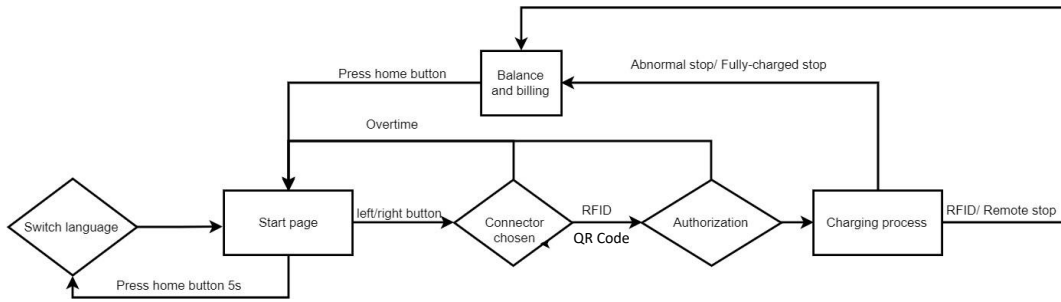

Figure 5.3.2

The explanation of keywords:

- Icon: the charging plug sign on screen;
- Overtime: There is no action or no proper operation from the user within specified time;
- RFID: Radio Frequency Identification card;
- Abnormal stop/ fully-charged stop: stop initiated by EVSE or EV;
- RFID/Remote stop: stop initiated by user.
- Language button: press question mark in the bottom right corner (just available for touch screen) and then the different languages can be selected shown below in Figure 5.3.3:

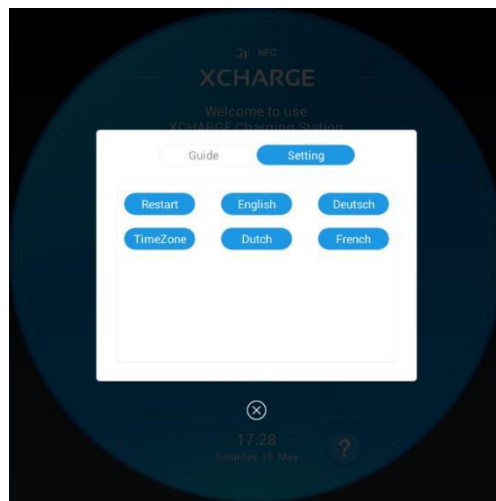
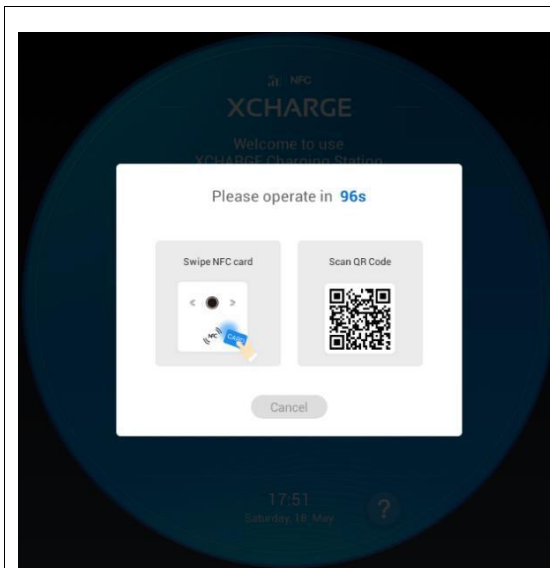

Figure 5.3.3 Setting page

The important steps are shown below as screenshot in Figure 5.3.4 (for single-plug version just one plug icon is shown on the screen and all the others are same as double plug):

Touch screen:	Non-touch screen:
1. Select charging icon and wait for the authentication	1. Select charging plug and wait for the authentication



2. Authentication passed, waiting for the official charging process

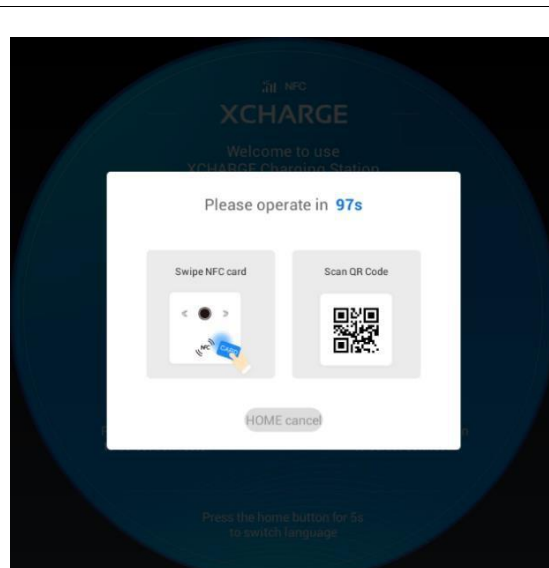

2. Authentication passed, waiting for the official charging process

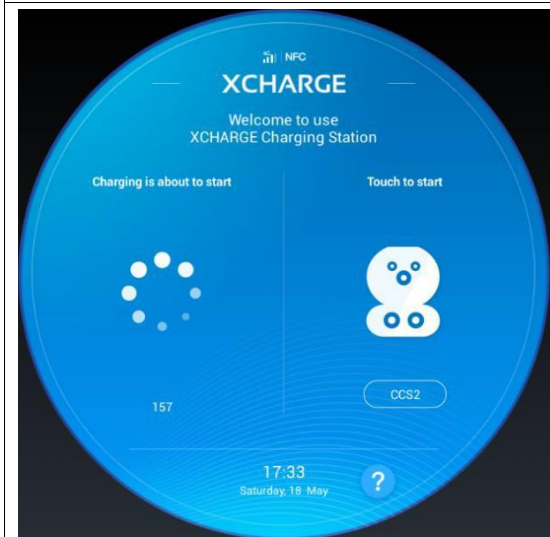

3. Charging process

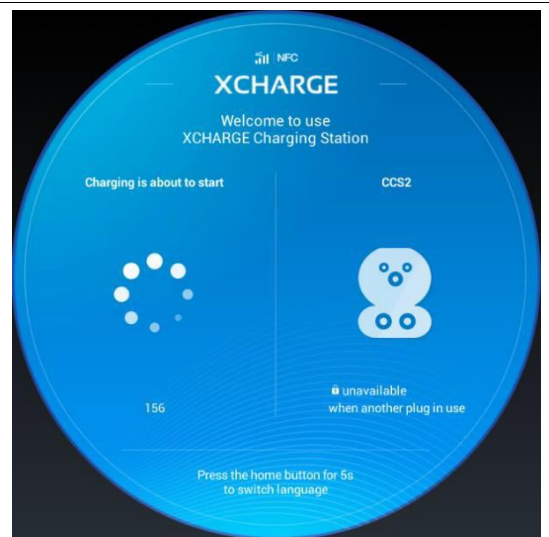

3. Charging process



4. The bill after charging

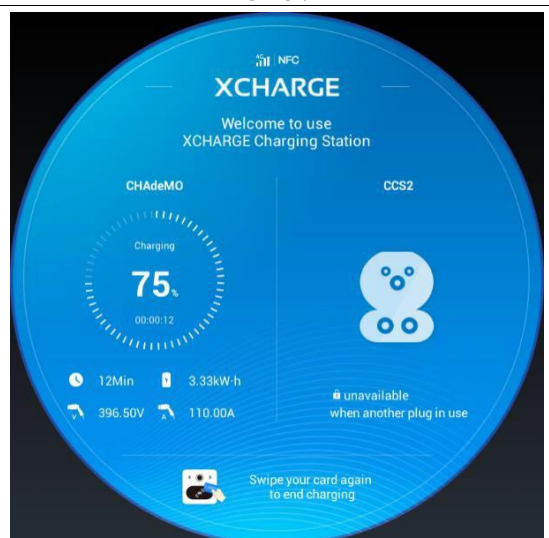

4. The bill after charging

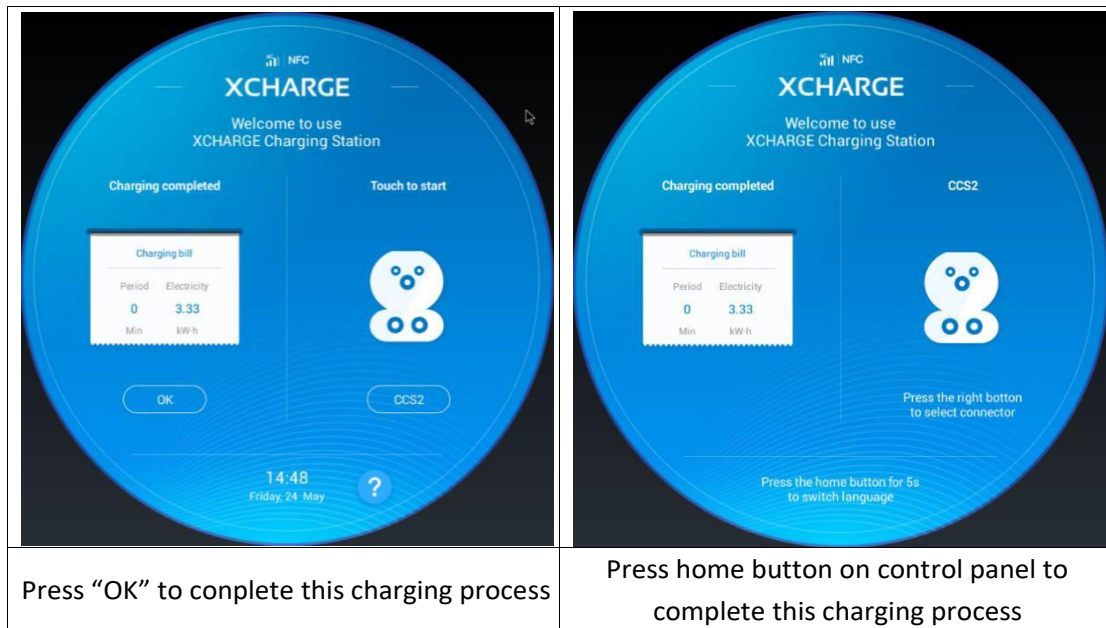

Figure 5.3.4 Screenshot of UI

5.4 Indicator Lights

Above the respective cable suspension is a widely visible LED indicator, which shows different statuses of the charging station.

Lights outline	Status
	Sleep mode
	Charging percentage
	Fully -charged
	System activation
	Error
	System self-checking

Figure 5.4.1 Status of LED indicator

6. Fault Diagnosis

- Charging station is equipped with automatic diagnosis function, and the fault will be directly displayed on the screen and sent to backend.
- If the charging station is online, users can call customer service, we will arrange online engineer for remote repair charging fault.
- If the charging station does not connect to network, please call the customer service, and we will arrange crew to repair and maintenance as soon as possible.

Error Code	Meaning	First-Aid checking	Responsibility
A0101	Charger communication failed Communication between A8 and DCB failed	Check hardware connection between A8 and DCB	EVSE
A0104	Power module communication failed or power module is not connected	Check that the DIG switch of the module is in the correct position, Check the CAN communication connection between power module and DCB module	EVSE
A0103	Meter for Plug 1/Plug 2 warning	Check the connection and communication of electricity meter 1/2 (RS485)	EVSE
A0105	insulation module alarm	Check insulation module power supply Check insulation module connection and communication (RS485)	EVSE

100F	Charger temperature alarm	Check ventilation system, dust filter and ventilation fan	EVSE
1012	BMS demand voltage is above or below limits	Check EV	EV
1013	L1-phase overvoltage	Check grid input	Grid
1014	L1-phase undervoltage	Check grid input	Grid
1015	L2-phase overvoltage	Check grid input	Grid
1016	L2-phase undervoltage	Check grid input	Grid
1017	L3-phase overvoltage	Check grid input	Grid
1018	L3-phase undervoltage	Check grid input	Grid
1023	Discharge check failure	Check power module	EVSE
1025	Insulation check failure	Please contact XCHARGE	EVSE
1080	Power module check failure	Please contact XCHARGE	EVSE
10A0	SPD warning	Check SPD status	EVSE
10B0	PE warning	Check PE connection	EVSE
2005	Plug 1 temperature alarm	Check status of plug 1	EVSE
2006	Plug 2 temperature alarm	Check status of plug 2	EVSE
2016	Plug DC contactor failure	Check plug DC contactor status	EVSE
2017	EV battery reverse wiring	Check EV	EV
2018	EV battery voltage abnormal	Check EV	EV
2019	EV battery overvoltage	Check EV	EV
2021	EV battery undervoltage	Check EV	EV
4002	The emergency stop button is pressed	Check the cause of emergency stop, restore emergency button	Unknown
4009	Switch DC contactor	Check switch DC contactor	EVSE

	failure	status	
4021	Charger front door opens	Check whether the door is closed, check whether the access control spring is working and whether the cable is connected	EVSE
4022	Charger back door opens	Check whether the door is closed, check whether the access control spring is working and whether the cable is connected	EVSE
4023	Power module failure	Please contact XCHARGE	EVSE
4025	The vehicle demand voltage exceeds power module rating	Check EV	EVSE
4026	Electromagnetic lock locking failure	Please contact XCHARGE	EVSE
4027	Electromagnetic lock unlocking operation failed	Please contact XCHARGE	EVSE
4028	Electromagnetic lock reset failed	Please contact XCHARGE	EVSE
5009	The power module is not energized	Check power module supply	EVSE
5010	Power module address conflict	Check if the DIG switch of the module is in right position	EVSE
5011	PE warning	Check PE connection	EVSE
5012	AC wiring of charger lacks phase	Check three phase connection	EVSE
6003	Water level alarm	Check if there is water exceeds detector	EVSE
6004	Relay check failure	Check relay	EVSE

6005	Electromagnetic lock check failure	Please contact XCHARGE	EVSE
-------------	------------------------------------	------------------------	------

Table 6.1

Notes:

- When scanning QR-code or sweeping NFC/RFID card to start charging and system shows self-test failure: due to the difference of EVs inlets, plug the socket again to ensure that the charging plug is in the right position and lock functions well.

7. Maintenance

 WARNING
<p>Mortal danger due to electrocution!</p> <p>The contact with high power parts can result in electric shock, burns or death. Before working, please put on the required protection device such as Protective clothing and gloves:</p> <ul style="list-style-type: none"> - The door should be open after the upstream circuit breaker and isolation switch in the distribution cabinet is closed. - Make sure that the power supply is disconnected while doing maintenance.

Make sure to put the charging plug back on the right side of the plug holder after charging and ensure that the charging cable is naturally drooping.

Regularly check the charging station and charging cable. If damage is found, you can contact the customer service for replacement or maintenance.

7.1 Cleaning of the Cabinet

- The C6AM Charge Station is powder coated. This coating must be kept in good condition;
- We suggest that C6AM needs to be cleaned two times every year (adjusted according to the actual situation);
- Remove rough dirt by spraying with low-pressure tap water instead of high-pressure jet;
- Apply a neutral or weak alkaline cleaning solution and let it soak;
- Only use cleaning agents with a PH value between 6 and 8;
- Do not use cleaning agents with abrasive components;
- Do not use abrasive tools;
- Remove dirt by hand with a non-woven nylon hand pad;
- Do a regular check on the coating for damage;
- Call the customer service if any damage on coating occurs.

 **CAUTION**

Anti-dust net is located at charging station air-inlet part, and please check the net every 3 months and conduct scheduled cleaning. If not, dust blockage may happen, causing internal components overheated.

7.2 Anti-dust Net Replacement

In order to change the anti-dust net in 10min, quick change method is applied. After opening the front door and lifting the lock bar, the cover will open, then wash, air-dry the net, install the anti-dust net and locks back.

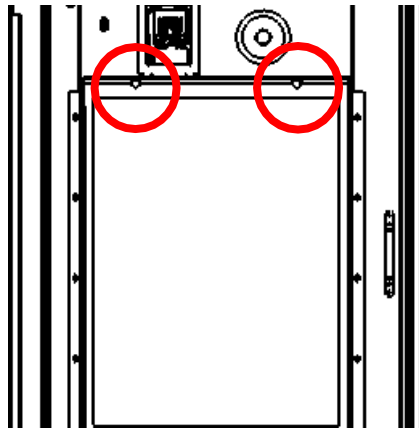

Figure 7.2.1

 **WARNING**

Danger of life!

Please shut down the input power before cleaning the charging station.

When opening the front and rear doors, please pay attention to prevent dust from entering the cabinet and clean if necessary.

8. Contact Information

Contact:

USA:

XCHARGE Energy USA Inc
326 North LBJ Drive, Suite 173,
San Marcos,
Texas,
United States of America
Tel: +86 010-57215988
Email: b@XCHARGE.com

China

Beijing XCHARGE Technology Co., Ltd.
12 Shuangyang Road
Daxing District
100176 Beijing CHINA
Tel: +86 010-57215988
Email: b@XCHARGE.com

FCC Information

To whom it may concern,

**This device complies with part 15 of the FCC Rules. Operation is subject to the following two conditions:
(1) This device may not cause harmful interference, and (2) this device must accept any interference received, including interference that may cause undesired operation.**

For class A digital device:

NOTE: This equipment has been tested and found to comply with the limits for a Class A digital device, pursuant to Part 15 of the FCC Rules. These limits are designed to provide reasonable protection against harmful interference when the equipment is operated in a commercial environment. This equipment generates, uses, and can radiate radio frequency energy and, if not installed and used in accordance with the instruction manual, may cause harmful interference to radio communications. Operation of this equipment in a residential area is likely to cause harmful interference in which case the user will be required to correct the interference at his own expense.

MODIFICATION: Any changes or modifications not expressly approved by the grantee of this device could void the user's authority to operate the device.

This equipment should be installed and operated with minimum distance of 20 cm between the radiator and your body.