

深圳市三盛创电子科技有限公司

承 認 書

客 戶:
CUSTOMER: 深圳市铭景天电子有限公司

客 戶 料 號:
CUST P/N:

三盛创 料 號:
FINE P/N: **G43.5-6.3UH 单线圈 0.08*105P*10TS**

產 品 型 號:
DESC: **Φ 43.5MMX5.3MMX0.8MM 开槽**

日 期:
DATE: **2023.07.26**

版 本:
Version: **A.0**

擬制 PREPARED BY	審核 CHECKED BY	批准 APPROVED BY	客戶承認 CUSTOMER APPROVE
郭柳	安帅印	安帅印	

**Shenzhen Sansheng Chuang electronic Technology
Co., LTD**

9 Yuquan East Road, Yutang Street, Guangming New District, Shenzhen

SPECIFICATION

產品型號: DESC	Φ 20.5x43-6.3uH-0.08x105-175mm	版本 Rev: A.0	客戶 CUST: 客戶料号 CUST P/N:	XXX
---------------	--------------------------------	----------------	----------------------------	------------

一、尺寸 DIMENSION:(mm)

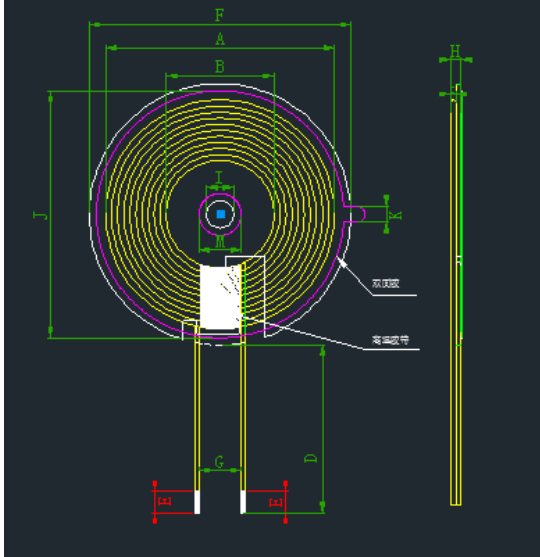

A	43.0±1.0
B	20.5±0.5
D	175±2
E	3±1.5
F	42.5±0.5
G	8.0 ±1
H	2.3 +0.2
I	5.3 ref
J	43.5±0.5
K	3.0±1

注:

- 1.交叉出线;
- 2.出线位置缠 8mm(ref)宽度高温胶纸 1-2Ts;
- 3.线圈贴圆形硬磁片带槽, 磁片尺寸 43.5±0.5mm,内孔 5.3mm,厚度为 0.8±0.1mm

二、原理图 SCHEMATIC DIAGRAM:

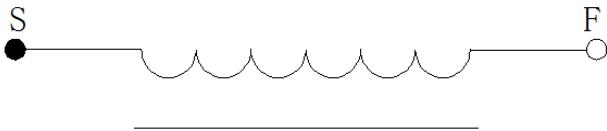

三、绕线参数 Winding Specification:

序号 NO.	端子 TERMINAL		线径 WIRE	圈数 Turns	绕线方向 Winding Direction
1	S	F	丝包线 0.08*105P	10Ts	CCW

四、电气特性 ELECTRICAL CHARACTERISTICS:

温度 TEMPERATURE:25±10 °C, 湿度 RELATIVE HUMIDITY:65±20%

序号 NO.	项目 ITEM	端子 TERMINAL	标准 SPECIFICATION	测试条件 TEST FREQUENCY	测试仪器 TEST EQUIPMENTS
1	IND.	S-F	3.8uH ±10%单独线圈	100KHz/1.0V	LCZ METER 1062B
2	IND.	S-F	6.3uH ±10%加磁片	100KHz/1.0V	LCZ METER 1062B
3	DCR	S-F	≤50mΩ	100KHz/1.0V	LCZ METER 502B
4	Q	S-F	≥78	100KHz/1.0V	LCZ METER 502B

擬制/日期 PREPARED BY/DATE	審核/日期 CHECKED BY/DATE
郭柳 2023.07.26	安帅印 2023.07.26

We statement that All measurements were performed radiated and therefore additional antenna gain documentation is not required.

三. 电路图/CIRCUITDIAGRAM

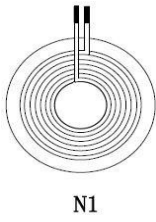

unit: MM

四. 外形图/OUTSIDE DIAGRA

Model: 50*0.8*5.1 * 0.08*105P引

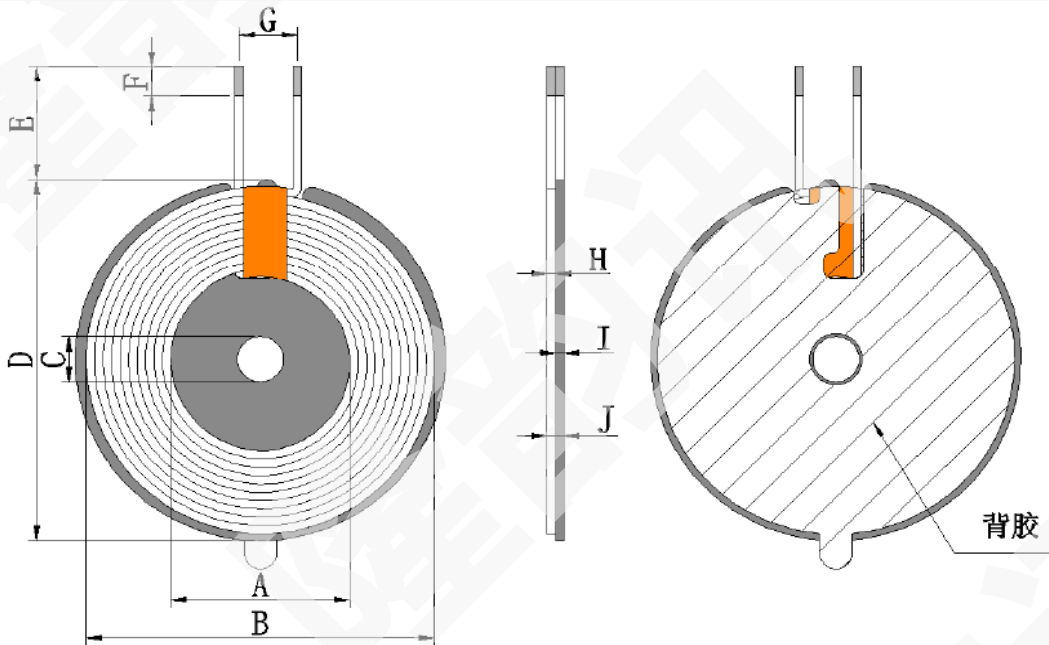

A	B	C	D	E	F	G	H	I	J
20.5±0.5	43±1	5.1±0.2	50±0.5	25±2	3.0±1	10±1	1.25MAX	1.0±0.15	2.7.0MAX

We statement that All measurements were performed radiated and therefore additional antenna gain documentation is not required.