

承认书

SPECIFICATION FOR APPROVAL

客户名称 : 深圳市乌托邦创意科技有限公司
CUSTOMER'S NAME : Shenzhen UTOPIA-Originality Technology.Co.,Ltd

客户料号 : 520-05670-0002
CUSTOMER'S P/N :

产品规格 : Y. WAC. 044
PRODUCT SPEC :

制作日期 : 2023年4月26日
ISSUE DATE : 2023.04.26

拟制 PREPARED BY	审核 CHECKED BY	批准 APPROVED BY	客户承认 CUSTOMER APPROVE
李蓓	程杰	李博文	



东莞市博红科技有限公司
DONGGUAN BOHONG TECHNOLOGY CO., LTD

ADD: 东莞市大朗镇富民中路533号4楼 4F, No.533 of FUMIN Middle Road, Dalong Town, Dongguan City

TEL: 0769-82866410

FAX: 0769-82866409

本承认书请在首批下单生产此机种前回签, 否则视为贵方默认此承认书内所有内容
Pls answer all below questions before the first order, otherwise, we thought you agreed all contents in below

东莞市博红科技有限公司
DONGGUAN BOHONG TECHNOLOGY CO., LTD
SPECIFICATION FOR APPROVAL

CUSTOMER	乌托邦/Utopia	CUSTOMER'S P/N 工程部部长专用章	520-05670-0002
ISSUE DATE	2023年4月26日	PRODUCT SPEC	Y. WAC. 044

2.DIMENSION:

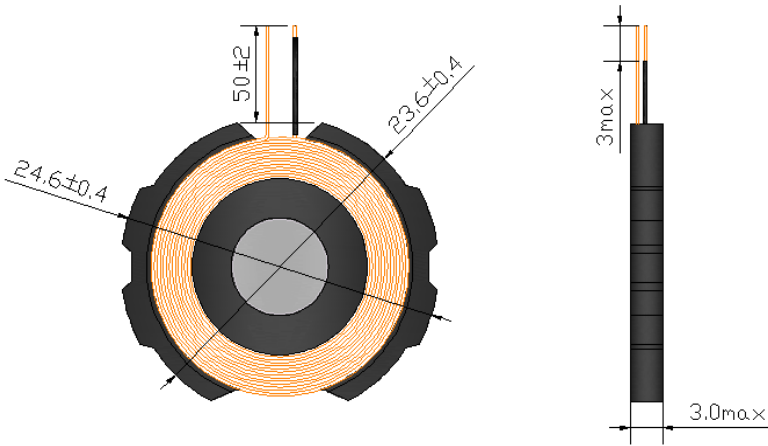

注:

背面 $\varnothing 19 * T0.13$ 皇冠513#双面胶;
 磁铁7.5*2mm高斯3200 ± 100 ;
 出线不交叉,套2根1.0/0.6*48mm热缩套管;

Remark

The Backside $\varnothing 19 * T0.13$ Crown 513 # double-sided tape;

Magnet 7.5 * 2mm Gaussian 3200 ± 100 ;

The outgoing lines do not cross, and two 1.0/0.6 * 48mm heat shrink sleeves are installed;

ISSUE BY	李蓓	CHECK BY	程定	APPROVAL BY	李博文
----------	-----------	----------	-----------	-------------	------------

东莞市博红科技有限公司
DONGGUAN BOHONG TECHNOLOGY CO., LTD
SPECIFICATION FOR APPROVAL

CUSTOMER	乌托邦/Utopia	CUSTOMER'S P/N <small>工程部专用章</small>	520-05670-0002
ISSUE DATE	2023年4月26日	PRODUCT SPEC	Y. WAC. 044

4. CIRCUIT DIAGRAM

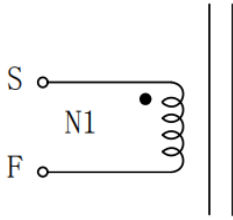

" • ": POLARITY/极性

5. WINDING

NO	WINDING	WIRE	TURNS	TAPE	WINDING CONDITION
N1	S-F	Ø0.08*24P	14	/	CCW

6. CHARACTERISTIC

ITEM	MEASURED POINT	TECHNICAL DATA	TESTING CONDITION & INSTRUMENT
LS	S-F	7.8uH - 8uH	LCR1062 100KHz/1V AT 25°C±2°C
Q	S-F	27±5	LCR1062 100KHz/1V AT 25°C±2°C

东莞市博红科技有限公司

DONGGUAN BOHONG TECHNOLOGY CO., LTD

SPECIFICATION FOR APPROVAL

CUSTOMER	乌托邦/Utopia	CUSTOMER'S P/N	520-05670-0002
ISSUE DATE	2023年4月26日	PRODUCT SPEC	Y. WAC. 044

7.THE PACKING WAY

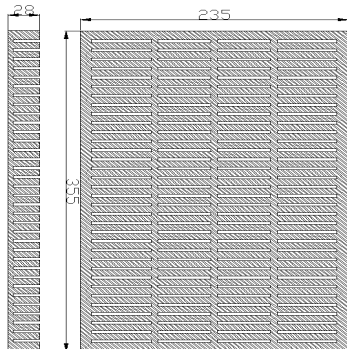

1. 珍珠棉规格: 375*265*30mm*120格; The EVA SPEC:375*265*30mm*120 hole
2. 每格装2pcs, 每盘240pcs; Each hole put 2 pcs, 24pcs/sheet
3. 每箱装10盘; 10 sheets in each carton
4. 每箱合计: 2400pcs; Total 2400 pcs for each carton
5. 纸箱材质: K=K++; The material of carton:K=K++

29

235

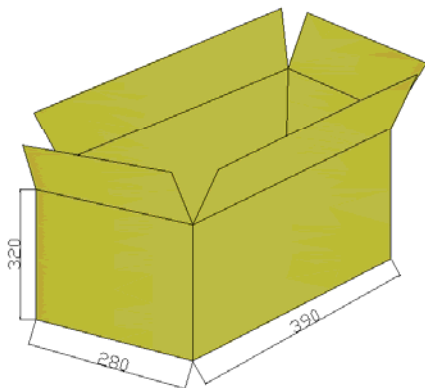

东莞市博红科技有限公司

DONGGUAN BOHONG TECHNOLOGY CO., LTD

SPECIFICATION FOR APPROVAL

CUSTOMER	乌托邦/Utopia	CUSTOMER'S P/N	520-05670-0002
ISSUE DATE	2023年4月26日	PRODUCT SPEC	Y. WAC. 044

备忘录

序号	内容 Content	处理方法 Methods	签名 Signature	日期 Date
1				
2				
3				
4				
5				
6				

7				
8				
9				
10				