

TEST REPORT

Applicant Name: Fanvil Link Technology Co.,LTD
Address: A03, A08, 3rd Floor, Building 2, Daqian Industrial Plant, Zone 67, Xingdong Community, Xin'an Street, Bao'an District, Shenzhen ,China
Report Number: 2401U79863E-RFB
FCC ID: 2BCUQ-V62W
IC: 32680-V62W

Test Standard (s)

FCC PART 15.247; RSS-GEN ISSUE 5, FEBRUARY 2021 AMENDMENT 2;
RSS-247 ISSUE 3, AUGUST 2023

Sample Description

Product Type: IP Phone
Model No.: V62W
Multiple Model(s) No.: V61W
Trade Mark: **Fanvil**
Date Received: 2024/06/11
Issue Date: 2024/08/05

Test Result:	Pass [▲]
--------------	-------------------

▲ In the configuration tested, the EUT complied with the standards above.

Prepared and Checked By:

Jojo Guo

Jojo Guo
RF Engineer

Approved By:

Nancy Wang

Nancy Wang
RF Supervisor

Note: The information marked # is provided by the applicant, the laboratory is not responsible for its authenticity and this information can affect the validity of the result in the test report. Customer model name, addresses, names, trademarks etc. are included.

This report cannot be reproduced except in full, without prior written approval of the Company. Unless otherwise stated the results shown in this test report refer only to the sample(s) tested. This report is valid only with a valid digital signature. The digital signature may be available only under the Adobe software above version 7.0.

This report must not be used by the customer to claim product certification, approval, or endorsement by NVLAP or any agency of the U.S. Government.

This report may contain data that are not covered by the NVLAP accreditation and are marked with an asterisk "▼".

Bay Area Compliance Laboratories Corp. (Shenzhen)

5F(B-West) , 6F, 7F, the 3rd Phase of Wan Li Industrial Building D, Shihua Rd, FuTian Free Trade Zone, Shenzhen, China
Tel: +86-755-33320018 Fax: +86-755-33320008 www.baclcorp.com.cn

TABLE OF CONTENTS

DOCUMENT REVISION HISTORY	4
GENERAL INFORMATION.....	5
PRODUCT DESCRIPTION FOR EQUIPMENT UNDER TEST (EUT)	5
OBJECTIVE	5
TEST METHODOLOGY	5
MEASUREMENT UNCERTAINTY	6
TEST FACILITY	6
SYSTEM TEST CONFIGURATION.....	7
DESCRIPTION OF TEST CONFIGURATION	7
EQUIPMENT MODIFICATIONS	7
EUT EXERCISE SOFTWARE	7
DUTY CYCLE	8
SUPPORT EQUIPMENT LIST AND DETAILS	8
EXTERNAL I/O CABLE.....	8
BLOCK DIAGRAM OF TEST SETUP	9
SUMMARY OF TEST RESULTS	11
TEST EQUIPMENT LIST	12
FCC §15.247 (I) & §1.1307 (B) (3) & §2.1091- RF EXPOSURE	13
APPLICABLE STANDARD	13
RESULT	14
RSS-102 ISSUE 5 § 2.5.2 - EXEMPTION LIMITS FOR ROUTINE EVALUATION-RF EXPOSURE EVALUATION	15
APPLICABLE STANDARD	15
RESULT	15
FCC §15.203 & RSS-GEN §6.8 - ANTENNA REQUIREMENT	16
APPLICABLE STANDARD	16
ANTENNA CONNECTOR CONSTRUCTION	16
FCC § 15.207 (A) & RSS-GEN §8.8 AC LINE CONDUCTED EMISSIONS	17
APPLICABLE STANDARD	17
EUT SETUP	18
EMI TEST RECEIVER SETUP.....	18
TEST PROCEDURE	18
FACTOR & OVER LIMIT CALCULATION.....	19
TEST DATA	19
FCC §15.209, §15.205 & §15.247(D), RSS-GEN § 8.10 & RSS-247 § 5.5 - UNWANTED EMISSION FREQUENCIES AND RESTRICTED BANDS.....	24
APPLICABLE STANDARD	24
EUT SETUP	24
EMI TEST RECEIVER & SPECTRUM ANALYZER SETUP	25
TEST PROCEDURE	26
FACTOR & OVER LIMIT/ MARGIN CALCULATION	26
TEST RESULTS SUMMARY	26
TEST DATA	26

FCC §15.247(A) (2), RSS-GEN § 6.7 & RSS-247 § 5.2 (A) - 99% OCCUPIED BANDWIDTH & 6 DB EMISSION BANDWIDTH44

 STANDARD APPLICABLE44

 TEST PROCEDURE45

 TEST DATA46

FCC §15.247(B) (3), RSS-247 §5.4 (D) - PEAK OUTPUT POWER MEASUREMENT47

 APPLICABLE STANDARD47

 TEST PROCEDURE47

 TEST DATA48

FCC §15.247(E), RSS-247 §5.2 (B) – POWER SPECTRAL DENSITY49

 APPLICABLE STANDARD49

 TEST PROCEDURE49

 TEST DATA50

FCC §15.247(D) & RSS-247 §5.5 - 100 KHZ BANDWIDTH OF FREQUENCY BAND EDGE51

 APPLICABLE STANDARD51

 TEST PROCEDURE51

 TEST DATA52

EUT PHOTOGRAPHS53

TEST SETUP PHOTOGRAPHS54

APPENDIX55

 APPENDIX A: DTS BANDWIDTH55

 APPENDIX B: OCCUPIED CHANNEL BANDWIDTH59

 APPENDIX C: MAXIMUM CONDUCTED OUTPUT POWER.....63

 APPENDIX D: MAXIMUM POWER SPECTRAL DENSITY66

 APPENDIX E: BAND EDGE MEASUREMENTS.....70

 APPENDIX F: DUTY CYCLE72

DOCUMENT REVISION HISTORY

Revision Number	Report Number	Description of Revision	Date of Revision
0	2401U79863E-RFB	Original Report	2024/08/05

GENERAL INFORMATION

Product Description for Equipment under Test (EUT)

HVIN	V62W, V61W
FVIN	Test_rf_telnet
Product	IP Phone
Tested Model	V62W
Multiple Model(s)	V61W
Frequency Range	BLE: 2402-2480MHz
Maximum Conducted Peak Output Power	BLE: 3.43dBm
Modulation Technique	BLE: GFSK
Antenna Specification [#]	5.1dBi (provided by the applicant)
Voltage Range	DC 5V from adapter or DC 48V from POE
Sample serial number	For Model: V62W: 2MMX-3 for Conducted and Radiated Emissions 2MMX-1 for RF Conducted Test For Model: V61W: 2MMX-8 for Conducted and Radiated Emissions (Assigned by BACL, Shenzhen)
Sample/EUT Status	Good condition
Adapter Information	Adapter 1 Model: F05L5-050100SPAU Input: AC 100-240V, 50/60Hz, 0.2A Output: DC 5.0V, 1.0A, 5.0W Adapter 2 Model: DCT06W050100US-D0 Input: AC 100-240V, 50/60Hz, 200mA Output: DC 5.0V, 1.0A
Note: The Multiple models are electrically identical with the test model except for model name, button, button PCB and sales channels. Please refer to the declaration letter [#] for more detail, which was provided by manufacturer.	

Objective

This report is in accordance with FCC Part 15, Subpart C, and section 15.203, 15.205, 15.209, 15.247 rules and RSS-GEN Issue 5, February 2021 Amendment 2 and RSS-247 Issue 3, August 2023 of the Innovation, Science and Economic Development Canada rules.

Test Methodology

All tests and measurements indicated in this document were performed in accordance ANSI C63.10-2013, RSS-GEN Issue 5, February 2021 Amendment 2 and RSS-247 Issue 3, August 2023.

And KDB 558074 D01 15.247 Meas Guidance v05r02.

All emissions measurement was performed at Bay Area Compliance Laboratories Corp. (Shenzhen). The radiated testing was performed at an antenna-to-EUT distance of 3 meters.

Each test item follows test standards and with no deviation.

Measurement Uncertainty

Parameter		Uncertainty
Occupied Channel Bandwidth		±5%
RF output power, conducted		0.72 dB(k=2, 95% level of confidence)
AC Power Lines Conducted Emissions	9kHz~150 kHz	3.94dB(k=2, 95% level of confidence)
	150 kHz ~30MHz	3.84dB(k=2, 95% level of confidence)
Radiated Emissions	9kHz - 30MHz	3.30dB(k=2, 95% level of confidence)
	30MHz~200MHz (Horizontal)	4.48dB(k=2, 95% level of confidence)
	30MHz~200MHz (Vertical)	4.55dB(k=2, 95% level of confidence)
	200MHz~1000MHz (Horizontal)	4.85dB(k=2, 95% level of confidence)
	200MHz~1000MHz (Vertical)	5.05dB(k=2, 95% level of confidence)
	1GHz - 6GHz	5.35dB(k=2, 95% level of confidence)
	6GHz - 18GHz	5.44dB(k=2, 95% level of confidence)
	18GHz - 40GHz	5.16dB(k=2, 95% level of confidence)
Temperature		±1°C
Humidity		±1%
Supply voltages		±0.4%

Note: The extended uncertainty given in this report is obtained by combining the standard uncertainty times the coverage factor K with the 95% confidence interval. Otherwise required by the applicant or Product Regulations, Decision Rule in this report did not consider the uncertainty.

Test Facility

The Test site used by Bay Area Compliance Laboratories Corp. (Shenzhen) to collect test data is located on the 5F(B-West) , 6F, 7F, the 3rd Phase of Wan Li Industrial Building D, Shihua Rd, FuTian Free Trade Zone, Shenzhen, China.

The lab has been recognized as the FCC accredited lab under the KDB 974614 D01 and is listed in the FCC Public Access Link (PAL) database, FCC Registration No. : 715558, the FCC Designation No. : CN5045.

The lab has been recognized by Innovation, Science and Economic Development Canada to test to Canadian radio equipment requirements, the CAB identifier: CN0023.

SYSTEM TEST CONFIGURATION

Description of Test Configuration

For BLE 1M/2M mode, 40 channels are provided to testing:

Channel	Frequency (MHz)	Channel	Frequency (MHz)
0	2402	20	2442
1	2404	21	2444
2	2406	22	2446
3	2408	23	2448
4	2410	24	2450
5	2412	25	2452
6	2414	26	2454
7	2416	27	2456
8	2418	28	2458
9	2420	29	2460
10	2422	30	2462
11	2424	31	2464
12	2426	32	2466
13	2428	33	2468
14	2430	34	2470
15	2432	35	2472
16	2434	36	2474
17	2436	37	2476
18	2438	38	2478
19	2440	39	2480

EUT was tested with Channel 0, 19 and 39.

Equipment Modifications

No modification was made to the EUT tested.

EUT Exercise Software

“Moba Xterm”[#] software was used to test and power level is Default[#]. The software and power level was provided by the applicant.

Duty cycle

Please refer to the Appendix.

Support Equipment List and Details

Manufacturer	Description	Model	Serial Number
BULL	Receptacle	GN-415K	5503290068073
Grandstream	IP Phone	GXV3480	T11223323B898
N/A	Earphone1	N/A	N/A
N/A	Earphone2	N/A	N/A
HIKVISION	Router	DS-3WR03	10021642429
Lenovo	PC	TIANYI510Pro-18ICB	R3NO28B21001

External I/O Cable

Cable Description	Length (m)	From Port	To
Un-shielded un-detachable AC cable	1.2	Receptacle	LISN/Mains
Un-shielded un-detachable DC cable	1.5	Adapter	EUT
Un-shielded detachable RJ45 cable	8.0	Router	EUT
Un-shielded detachable RJ45 cable	8.0	PC	EUT
Un-shielded detachable RJ45 cable	1.0	Router	IP Phone

Block Diagram of Test Setup

For conducted emission:

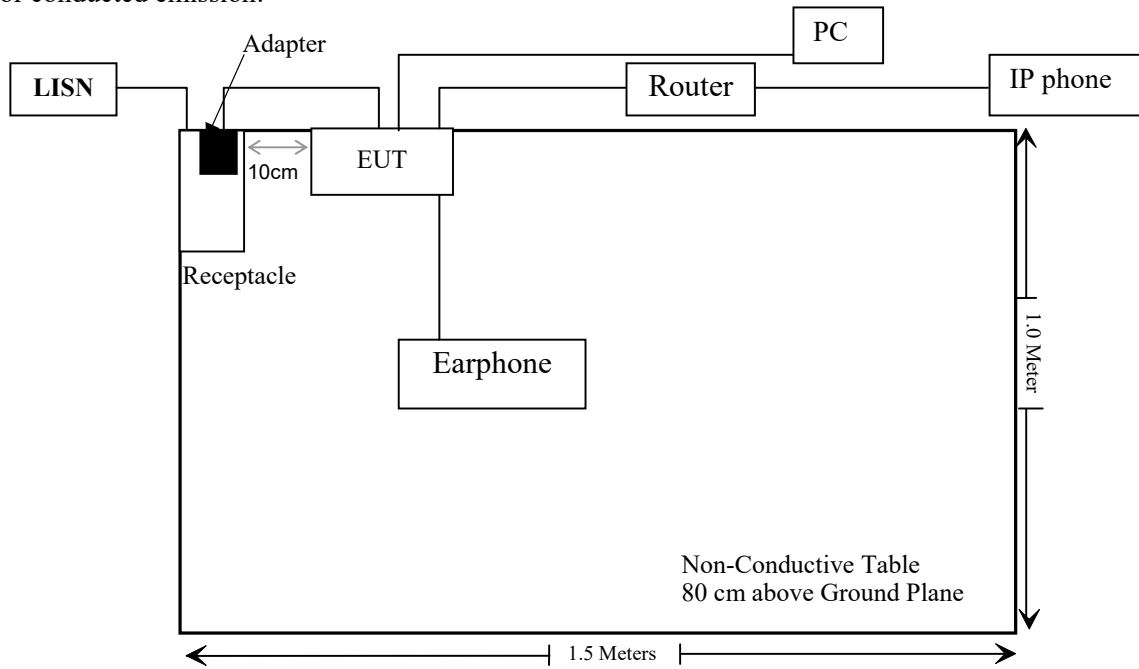

For radiated emission below 1GHz:

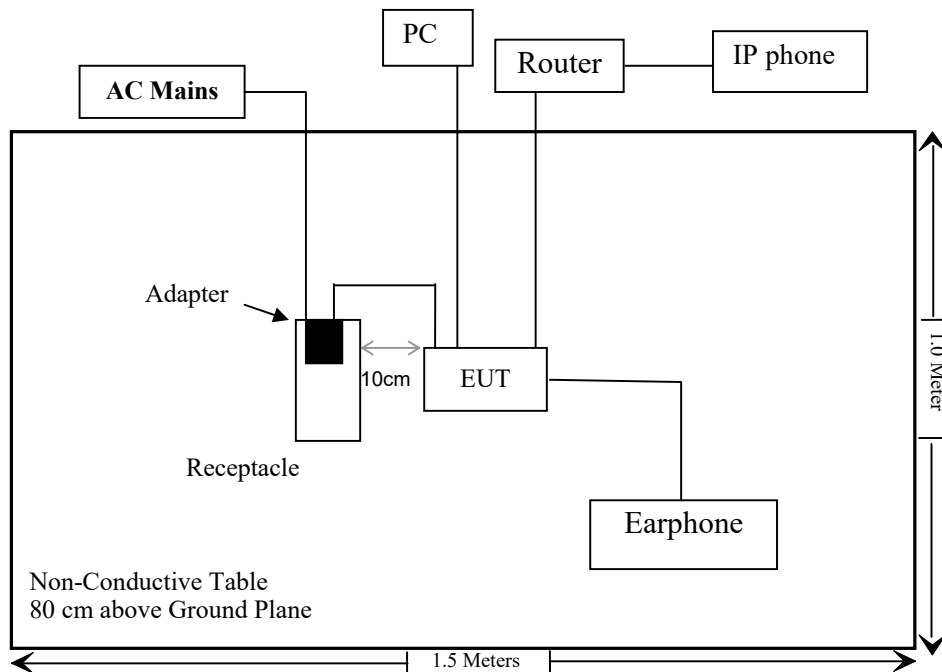

For radiated emission above 1GHz:

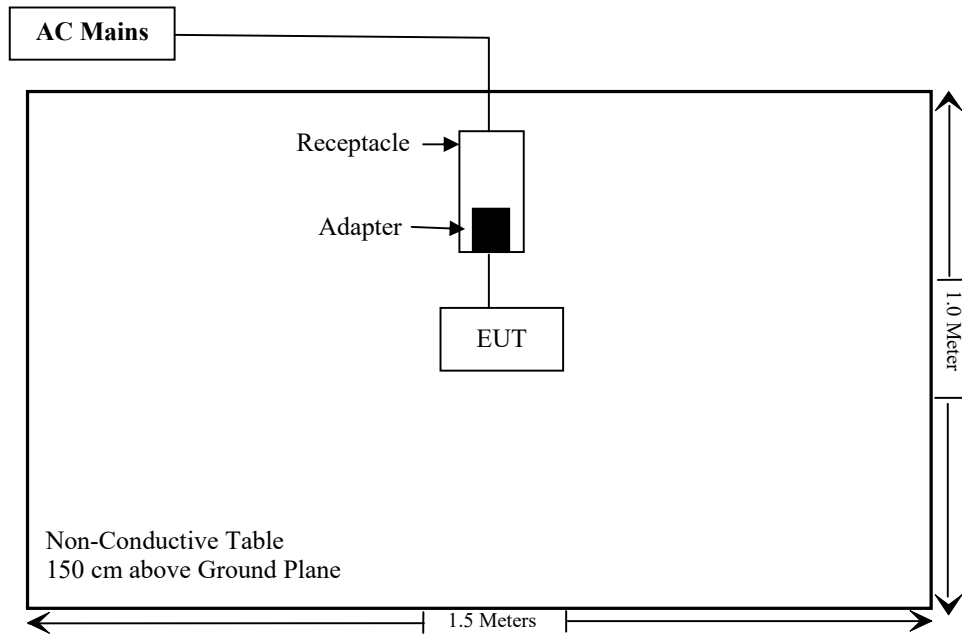

SUMMARY OF TEST RESULTS

FCC Rules	RSS Rules	Description of Test	Result
§15.247 (i), §1.1307 (b) (3) & §2.1091	RSS-102 ISSUE 5 § 2.5.2	RF Exposure & Exemption Limits for Routine Evaluation – RF Exposure Evaluation	Compliant
§15.203	RSS-Gen §6.8	Antenna Requirement	Compliant
§15.207 (a)	RSS-Gen §8.8	AC Line Conducted Emissions	Compliant
§15.205, §15.209, §15.247(d)	RSS-GEN § 8.10 & RSS-247 § 5.5	Spurious Emissions	Compliant
§15.247 (a)(2)	RSS- Gen§6.7 RSS-247 § 5.2 (a)	99% Occupied Bandwidth & 6 dB Emission Bandwidth	Compliant
§15.247(b)(3)	RSS-247 § 5.4(d)	Maximum Conducted Output Power	Compliant
§15.247(e)	RSS-247 § 5.2 (b)	Power Spectral Density	Compliant
§15.247(d)	RSS-247 § 5.5	100 kHz Bandwidth of Frequency Band Edge	Compliant

TEST EQUIPMENT LIST

Manufacturer	Description	Model	Serial Number	Calibration Date	Calibration Due Date
Conducted Emission Test					
Unknown	CE Cable	Unknown	UF A210B-1-0720-504504	2024/05/21	2025/05/20
Rohde & Schwarz	EMI Test Receiver	ESCI	101120	2024/01/16	2025/01/15
Rohde & Schwarz	LISN	ENV216	101613	2024/01/16	2025/01/15
Rohde & Schwarz	Transient Limiter	ESH3Z2	DE25985	2024/05/21	2025/05/20
Audix	EMI Test software	E3	191218(V9)	NCR	NCR
Radiated Emission Test					
Sunol Sciences	Broadband Antenna	JB1	A040904-1	2023/07/20	2026/07/19
Rohde & Schwarz	EMI Test Receiver	ESR3	102455	2024/01/16	2025/01/15
Sonoma instrument	Pre-amplifier	310N	186238	2024/05/21	2025/05/20
BACL	Active Loop Antenna	1313-1A	4031911	2024/05/14	2027/05/13
Unknown	Cable	Chamber Cable 1	F-03-EM236	2024/05/21	2025/05/20
Unknown	Cable	XH500C	J-10M-A	2024/05/21	2025/05/20
A.H.System	Pre-amplifier	PAM-1840VH	190	2023/08/02	2024/08/01
Electro-Mechanics Co	Horn Antenna	3116	9510-2270	2023/09/18	2026/09/17
SNSD	2.4G Band Reject filter	BSF2402-2480MN-0898-001	2.4G filter	2023/08/03	2024/08/02
Unknown	RF Cable	KMSE	0735	2023/10/08	2024/10/07
Unknown	RF Cable	XH750A-N	J-10M	2024/06/18	2025/06/17
Unknown	RF Cable	UFA147	219661	2023/10/08	2024/10/07
Schwarzbeck	Horn Antenna	BBHA9120D(1201)	1143	2023/07/26	2026/07/25
COM-POWER	Pre-amplifier	PA-122	181919	2024/06/18	2025/06/17
Rohde&Schwarz	Spectrum Analyzer	FSV40	101605	2024/03/27	2025/03/26
Audix	EMI Test software	E3	19821b(V9)	NCR	NCR
RF Conducted Test					
Rohde &Schwarz	Spectrum Analyzer	FSV40	101473	2024/01/16	2025/01/15
Tonscend	RF control Unit	JS0806-2	19D8060154	2023/09/06	2024/09/05
MARCONI	10dB Attenuator	6534/3	2942	2024/06/27	2025/06/26

* **Statement of Traceability:** Bay Area Compliance Laboratories Corp. (Shenzhen) attests that all calibrations have been performed in accordance to requirements that traceable to National Primary Standards and International System of Units (SI).

FCC §15.247 (i) & §1.1307 (b) (3) & §2.1091- RF EXPOSURE

Applicable Standard

According to KDB 447498 D04 Interim General RF Exposure Guidance

MPE-Based Exemption:

An alternative to the SAR-based exemption is provided in § 1.1307(b)(3)(i)(C), for a much wider frequency range, from 300 kHz to 100 GHz, applicable for separation distances greater or equal to $\lambda/2\pi$, where λ is the free-space operating wavelength in meters. The MPE-based test exemption condition is in terms of ERP, defined as the product of the maximum antenna gain and the delivered maximum time-averaged power. For this case, a RF source is an RF exempt device if its ERP (watts) is no more than a frequency-dependent value, as detailed tabular form in Appendix B. These limits have been derived based on the basic specifications on Maximum Permissible Exposure (MPE) considered for the FCC rules in § 1.1310(e)(1).

Table 1 to § 1.1307(b)(3)(i)(C) - Single RF Sources Subject to Routine Environmental Evaluation

RF Source frequency (MHz)	Threshold ERP (watts)
0.3-1.34	$1,920 R^2$.
1.34-30	$3,450 R^2/f^2$.
30-300	$3.83 R^2$.
300-1,500	$0.0128 R^2f$.
1,500-100,000	$19.2R^2$.

f = frequency in MHz;

R = minimum separation distance from the body of a nearby person (appropriate units, e.g., m);

For multiple RF sources: Multiple RF sources are exempt if:

in the case of fixed RF sources operating in the same time-averaging period, or of multiple mobile or portable RF sources within a device operating in the same time averaging period, if the sum of the fractional contributions to the applicable thresholds is less than or equal to 1 as indicated in the following equation:

$$\sum_{i=1}^a \frac{P_i}{P_{th,i}} + \sum_{j=1}^b \frac{ERP_j}{ERP_{th,j}} + \sum_{k=1}^c \frac{Evaluated_k}{Exposure Limit_k} \leq 1$$

Result

For worst case:

Mode	Frequency (MHz)	Tune up conducted power [#]	Antenna Gain [#]		ERP		Evaluation Distance (m)	ERP Limit (mW)
		(dBm)	(dBi)	(dBd)	(dBm)	(mW)		
BLE	2402-2480	4.0	5.1	2.95	6.95	4.95	0.2	768

Note 1: The tune-up power and antenna gain was declared by the applicant.

Note 2: 0dBd=2.15dBi.

Note 3: The BT and wifi cannot transmit at same time.

To maintain compliance with the FCC’s RF exposure guidelines, place the equipment at least 20cm from nearby persons.

Result: Compliant

RSS-102 ISSUE 5 § 2.5.2 - EXEMPTION LIMITS FOR ROUTINE EVALUATION- RF EXPOSURE EVALUATION

Applicable Standard

According to RSS-102 ISSUE 5 § (2.5.2):

RF exposure evaluation is required if the separation distance between the user and/or bystander and the device's radiating element is greater than 20 cm, except when the device operates as follows:

- below 20 MHz and the source-based, time-averaged maximum e.i.r.p. of the device is equal to or less than 1 W (adjusted for tune-up tolerance);
- at or above 20 MHz and below 48 MHz and the source-based, time-averaged maximum e.i.r.p. of the device is equal to or less than $4.49/f^{0.5}$ W (adjusted for tune-up tolerance), where f is in MHz;
- at or above 48 MHz and below 300 MHz and the source-based, time-averaged maximum e.i.r.p. of the device is equal to or less than 0.6 W (adjusted for tune-up tolerance);
- at or above 300 MHz and below 6 GHz and the source-based, time-averaged maximum e.i.r.p. of the device is equal to or less than $1.31 \times 10^{-2} f^{0.6834}$ W (adjusted for tune-up tolerance), where f is in MHz;
- at or above 6 GHz and the source-based, time-averaged maximum e.i.r.p. of the device is equal to or less than 5 W (adjusted for tune-up tolerance). In these cases, the information contained in the RF exposure technical brief may be limited to information that demonstrates how the e.i.r.p. was derived.

Result

Calculated Data:

The max tune-up conducted output power is 4.0 dBm, antenna gain is 5.1dBi.

Time-averaged maximum e.i.r.p. of the device is $4.0\text{dBm} + 5.1\text{dBi} = 9.1\text{dBm} = 0.008\text{ W}$

The worst case is $f = 2402\text{ MHz}$:

The limit is $1.31 \times 10^{-2} f^{0.6834} \text{ W} = 2.69\text{ W}$

$0.008\text{ W} < 2.68\text{ W}$

Note: The BT and wifi cannot transmit at same time.

So the RF Exposure evaluation can be exempted.

FCC §15.203 & RSS-GEN §6.8 - ANTENNA REQUIREMENT

Applicable Standard

According to FCC § 15.203, an intentional radiator shall be designed to ensure that no antenna other than that furnished by the responsible party shall be used with the device. The use of a permanently attached antenna or of an antenna that uses a unique coupling to the intentional radiator shall be considered sufficient to comply with the provisions of this Section. The manufacturer may design the unit so that a broken antenna can be replaced by the user, but the use of a standard antenna jack or electrical connector is prohibited.

According to FCC § 15.203, the applicant for equipment certification shall provide a list of all antenna types that may be used with the transmitter, where applicable (i.e. for transmitters with detachable antenna), indicating the maximum permissible antenna gain (in dBi) and the required impedance for each antenna. The test report shall demonstrate the compliance of the transmitter with the limit for maximum equivalent isotropically radiated power (e.i.r.p.) specified in the applicable RSS, when the transmitter is equipped with any antenna type, selected from this list.

For expediting the testing, measurements may be performed using only the antenna with highest gain of each combination of transmitter and antenna type, with the transmitter output power set at the maximum level. However, the transmitter shall comply with the applicable requirements under all operational conditions and when in combination with any type of antenna from the list provided in the test report (and in the notice to be included in the user manual, provided below).

When measurements at the antenna port are used to determine the RF output power, the effective gain of the device’s antenna shall be stated, based on a measurement or on data from the antenna’s manufacturer.

The test report shall state the RF power, output power setting and spurious emission measurements with each antenna type that is used with the transmitter being tested.

For licence-exempt equipment with detachable antennas, the user manual shall also contain the following notice in a conspicuous location:

This radio transmitter [enter the device’s ISED certification number] has been approved by Innovation, Science and Economic Development Canada to operate with the antenna types listed below, with the maximum permissible gain indicated. Antenna types not included in this list that have a gain greater than the maximum gain indicated for any type listed are strictly prohibited for use with this device. Immediately following the above notice, the manufacturer shall provide a list of all antenna types which can be used with the transmitter, indicating the maximum permissible antenna gain (in dBi) and the required impedance for each antenna type.

Antenna Connector Construction

The EUT has one internal antenna arrangement which was permanently attached and the maximum antenna gain# is 5.1dBi, fulfill the requirement of this section. Please refer to the EUT photos.

Antenna Type	Antenna Gain#	Impedance	Frequency Range
Integral	5.1dBi	50Ω	2.4~2.5GHz

Result: Compliant

FCC § 15.207 (a) & RSS-GEN §8.8 AC LINE CONDUCTED EMISSIONS

Applicable Standard

FCC§15.207 (a) & RSS-GEN §8.8

Unless stated otherwise in the applicable RSS, for radio apparatus that are designed to be connected to the public utility AC power network, the radio frequency voltage that is conducted back onto the AC power line on any frequency or frequencies within the range 150 kHz to 30 MHz shall not exceed the limits in table 4, as measured using a 50 μ H / 50 Ω line impedance stabilization network. This requirement applies for the radio frequency voltage measured between each power line and the ground terminal of each AC power-line mains cable of the EUT.

For an EUT that connects to the AC power lines indirectly, through another device, the requirement for compliance with the limits in table 4 shall apply at the terminals of the AC power-line mains cable of a representative support device, while it provides power to the EUT. The lower limit applies at the boundary between the frequency ranges. The device used to power the EUT shall be representative of typical applications.

Table 4 - AC Power Lines Conducted Emission Limits		
Frequency range (MHz)	Conducted limit (dBμV)	
	Quasi-Peak	Average
0.15 – 0.5	66 to 56 ¹	56 to 46 ¹
0.5 – 5	56	46
5 – 30	60	50

Note 1: The level decreases linearly with the logarithm of the frequency.

For an EUT with a permanent or detachable antenna operating between 150 kHz and 30 MHz, the AC power-line conducted emissions must be measured using the following configurations:

- (a) Perform the AC power-line conducted emissions test with the antenna connected to determine compliance with the limits of table 4 outside the transmitter's fundamental emission band.
- (b) Retest with a dummy load instead of the antenna to determine compliance with the limits of table 4 within the transmitter's fundamental emission band. For a detachable antenna, remove the antenna and connect a suitable dummy load to the antenna connector. For a permanent antenna, remove the antenna and terminate the RF output with a dummy load or network that simulates the antenna in the fundamental frequency band.

EUT Setup

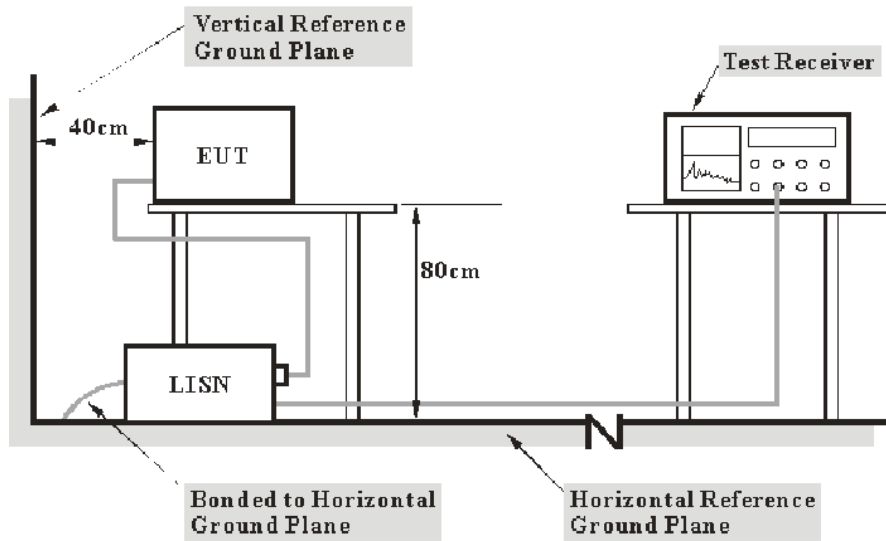

- Note: 1. Support units were connected to second LISN.
 2. Both of LISNs (AMN) 80 cm from EUT and at the least 80 cm from other units and other metal planes support units.

The setup of EUT is according with per ANSI C63.10-2013 measurement procedure. The specification used was with the FCC Part 15.207 & RSS-247/RSS-Gen limits.

The spacing between the peripherals was 10 cm.

The external I/O cables were draped along the test table and formed a bundle 30 to 40 cm long in the middle.

EMI Test Receiver Setup

The EMI test receiver was set to investigate the spectrum from 150 kHz to 30 MHz.

During the conducted emission test, the EMI test receiver was set with the following configurations:

Frequency Range	IF B/W
150 kHz – 30 MHz	9 kHz

Test Procedure

Maximizing procedure was performed on the six (6) highest emissions of the EUT.

All final data was recorded in the Quasi-peak and average detection mode.

Factor & Over Limit Calculation

The factor is calculated by adding LISN VDF (Voltage Division Factor) and Cable Loss. The basic equation is as follows:

$$\text{Factor} = \text{LISN VDF} + \text{Cable Loss}$$

The “**Over limit**” column of the following data tables indicates the degree of compliance with the applicable limit. For example, an Over limit of -7 dB means the emission is 7 dB below the limit. The equation for calculation is as follows:

$$\begin{aligned} \text{Over Limit} &= \text{Level} - \text{Limit} \\ \text{Level} &= \text{Read Level} + \text{Factor} \end{aligned}$$

Note: The term "cable loss" refers to the combination of a cable and a 10dB transient limiter (attenuator).

Test Data

Environmental Conditions

Temperature:	25 °C
Relative Humidity:	75 %
ATM Pressure:	101 kPa

The testing was performed by Macy Shi on 2024-07-19.

EUT operation mode: Transmitting (maximum output power mode BLE 1M, Low Channel)

Note: according to the test result of BT report, the adapter 2 was worst case, so the worst case adapter 2 was tested in this report.

Note: for the POE power mode was evaluated under the worst case mode(BT) according to the result of adapter, it was verified POE power mode compliance with requirement, so the POE mode not performed in this report.

For Model: V62W

AC 120V/60 Hz, Line

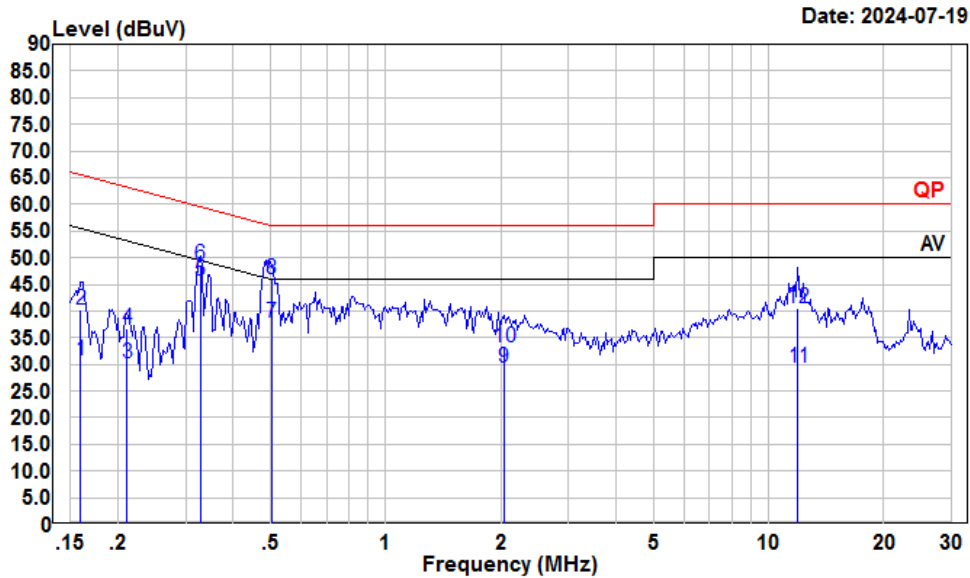

Condition: Line
 Project : 2401U79863E-RF
 tester : Macy.shi
 Note : BLE

	Read Freq	Read Level	LISN Level	LISN Factor	Cable Loss	Limit Line	Over Limit	Remark
	MHz	dBuV	dBuV	dB	dB	dBuV	dB	
1	0.16	9.83	30.83	10.88	10.12	55.47	-24.64	Average
2	0.16	19.36	40.36	10.88	10.12	65.47	-25.11	QP
3	0.21	9.25	30.12	10.78	10.09	53.18	-23.06	Average
4	0.21	15.86	36.73	10.78	10.09	63.18	-26.45	QP
5	0.33	24.93	45.69	10.64	10.12	49.49	-3.80	Average
6	0.33	27.95	48.71	10.64	10.12	59.49	-10.78	QP
7	0.50	17.28	37.92	10.50	10.14	46.00	-8.08	Average
8	0.50	25.41	46.05	10.50	10.14	56.00	-9.95	QP
9	2.03	8.70	29.48	10.59	10.19	46.00	-16.52	Average
10	2.03	12.51	33.29	10.59	10.19	56.00	-22.71	QP
11	11.93	8.44	29.25	10.60	10.21	50.00	-20.75	Average
12	11.93	19.83	40.64	10.60	10.21	60.00	-19.36	QP

AC 120V/60 Hz, Neutral

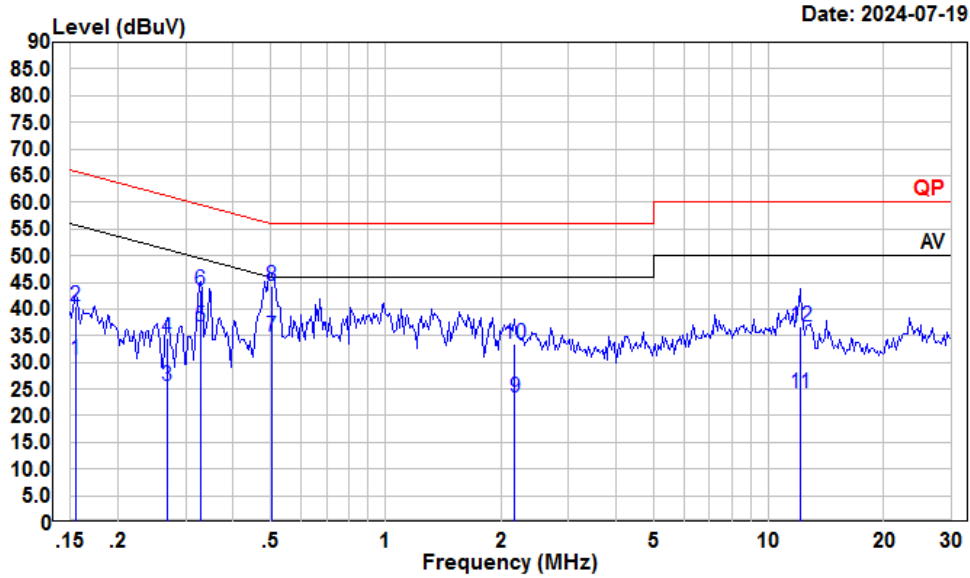

Condition: Neutral
 Project : 2401U79863E-RF
 tester : Macy.shi
 Note : BLE

	Read Freq	Read Level	LISN Level	LISN Factor	Cable Loss	Limit Line	Over Limit	Remark
	MHz	dBuV	dBuV	dB	dB	dBuV	dB	
1	0.15	9.79	30.49	10.58	10.12	55.74	-25.25	Average
2	0.15	19.78	40.48	10.58	10.12	65.74	-25.26	QP
3	0.27	4.96	25.55	10.50	10.09	51.16	-25.61	Average
4	0.27	13.96	34.55	10.50	10.09	61.16	-26.61	QP
5	0.33	16.00	36.68	10.56	10.12	49.49	-12.81	Average
6	0.33	22.70	43.38	10.56	10.12	59.49	-16.11	QP
7	0.50	13.93	34.77	10.70	10.14	46.00	-11.23	Average
8	0.50	23.59	44.43	10.70	10.14	56.00	-11.57	QP
9	2.17	2.86	23.44	10.40	10.18	46.00	-22.56	Average
10	2.17	12.94	33.52	10.40	10.18	56.00	-22.48	QP
11	12.06	3.15	24.16	10.80	10.21	50.00	-25.84	Average
12	12.06	15.72	36.73	10.80	10.21	60.00	-23.27	QP

For Model: V61W

AC 120V/60 Hz, Line

Date: 2024-07-19

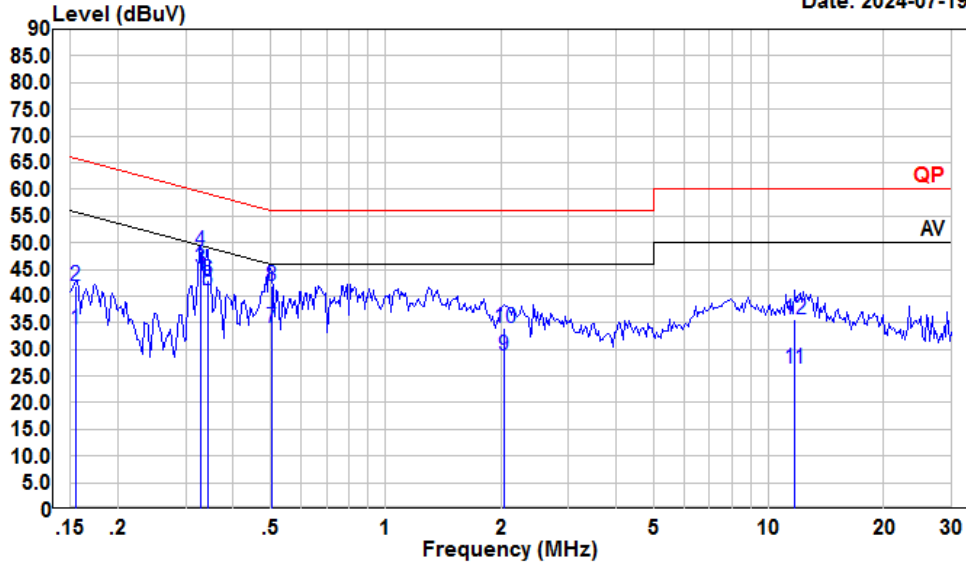

Condition: Line
 Project : 2401U79863E-RF
 tester : Macy.shi
 Note : BLE

	Read Freq	Read Level	LISN Level	LISN Factor	Cable Loss	Limit Line	Over Limit	Remark
	MHz	dBuV	dBuV	dB	dB	dBuV	dB	
1	0.15	12.63	33.64	10.89	10.12	55.74	-22.10	Average
2	0.15	20.78	41.79	10.89	10.12	65.74	-23.95	QP
3	0.33	24.51	45.27	10.64	10.12	49.49	-4.22	Average
4	0.33	27.52	48.28	10.64	10.12	59.49	-11.21	QP
5	0.34	20.30	41.04	10.62	10.12	49.13	-8.09	Average
6	0.34	22.10	42.84	10.62	10.12	59.13	-16.29	QP
7	0.50	13.38	34.02	10.50	10.14	46.00	-11.98	Average
8	0.50	21.24	41.88	10.50	10.14	56.00	-14.12	QP
9	2.03	7.95	28.73	10.59	10.19	46.00	-17.27	Average
10	2.03	13.29	34.07	10.59	10.19	56.00	-21.93	QP
11	11.68	5.68	26.49	10.60	10.21	50.00	-23.51	Average
12	11.68	14.79	35.60	10.60	10.21	60.00	-24.40	QP

AC 120V/60 Hz, Neutral

Date: 2024-07-19

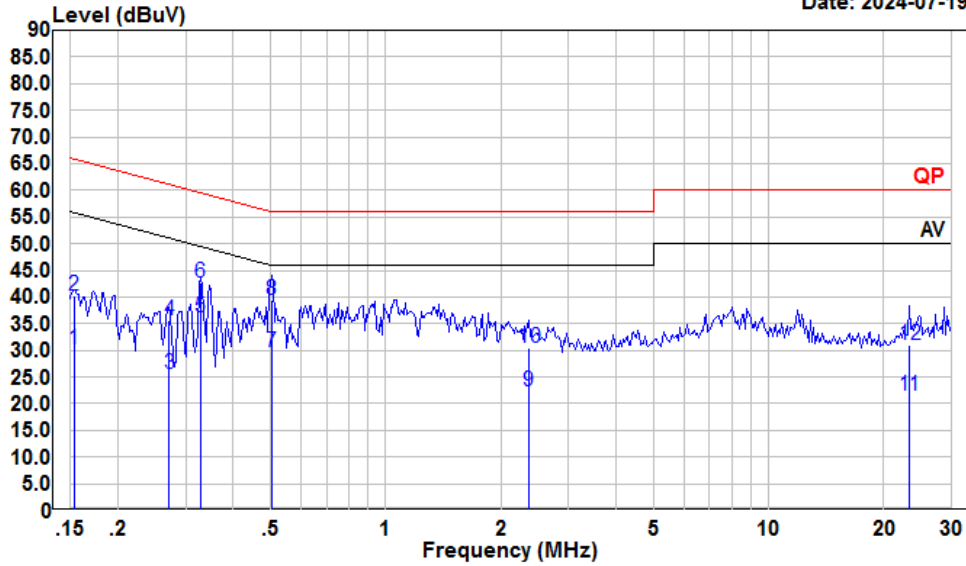

Condition: Neutral
 Project : 2401U79863E-RF
 tester : Macy.shi
 Note : BLE

	Read Freq	Read Level	LISN Level	LISN Factor	Cable Loss	Limit Line	Over Limit	Remark
	MHz	dBuV	dBuV	dB	dB	dBuV	dB	
1	0.15	9.43	30.15	10.59	10.13	55.82	-25.67	Average
2	0.15	19.56	40.28	10.59	10.13	65.82	-25.54	QP
3	0.27	4.88	25.47	10.50	10.09	51.07	-25.60	Average
4	0.27	14.94	35.53	10.50	10.09	61.07	-25.54	QP
5	0.33	15.40	36.08	10.56	10.12	49.49	-13.41	Average
6	0.33	22.10	42.78	10.56	10.12	59.49	-16.71	QP
7	0.50	8.77	29.61	10.70	10.14	46.00	-16.39	Average
8	0.50	18.72	39.56	10.70	10.14	56.00	-16.44	QP
9	2.36	1.67	22.25	10.40	10.18	46.00	-23.75	Average
10	2.36	9.85	30.43	10.40	10.18	56.00	-25.57	QP
11	23.26	0.72	21.53	10.63	10.18	50.00	-28.47	Average
12	23.26	10.10	30.91	10.63	10.18	60.00	-29.09	QP

FCC §15.209, §15.205 & §15.247(D), RSS-GEN § 8.10 & RSS-247 § 5.5 - UNWANTED EMISSION FREQUENCIES AND RESTRICTED BANDS

Applicable Standard

FCC §15.247 (d); §15.209; §15.205; RSS-247 §5.5, RSS-GEN §8.10.

EUT Setup

9 kHz-30MHz:

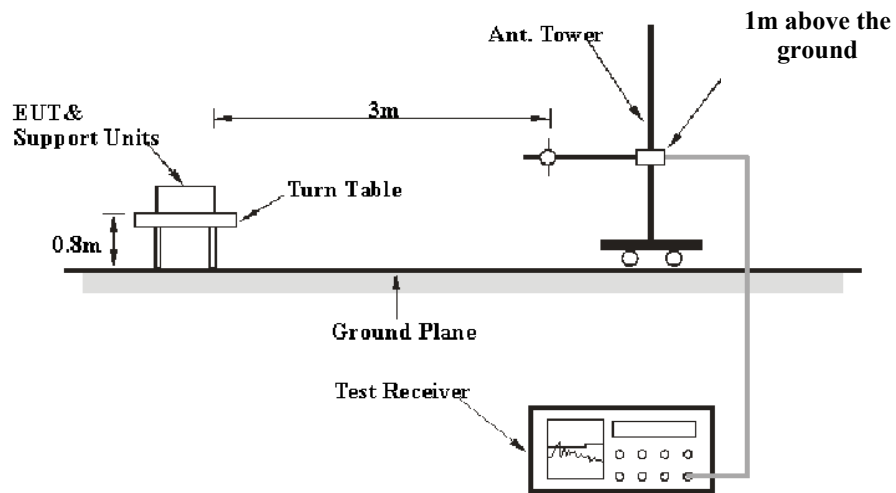

30MHz-1GHz:

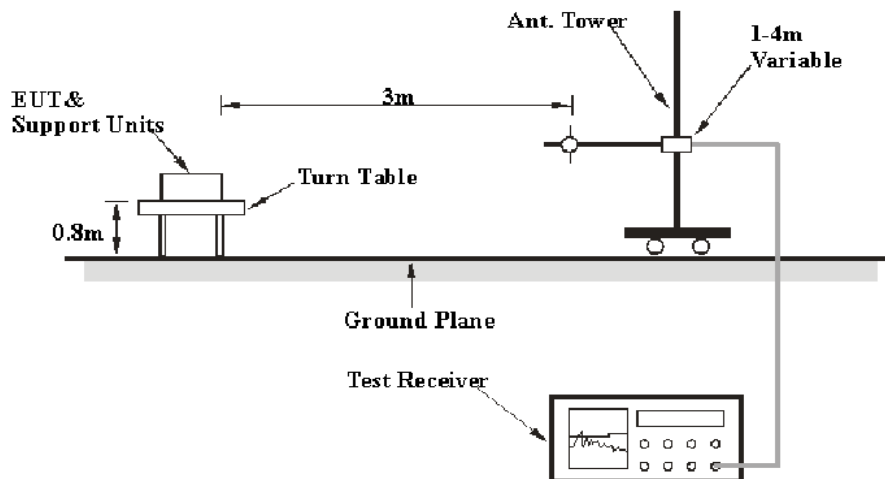

Above 1GHz:

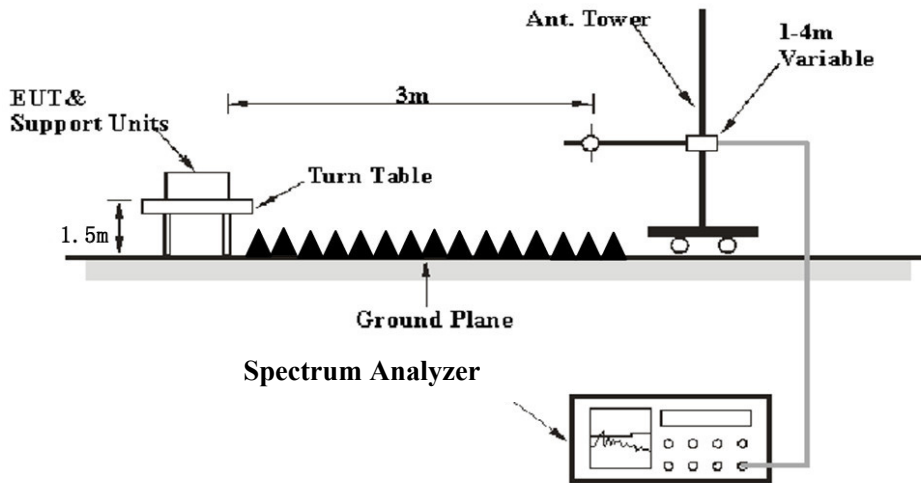

The radiated emission tests were performed in the 3meters test site, using the setup accordance with the ANSI C63.10-2013. The specification used was the FCC 15.205, FCC 15.209, FCC 15.247, RSS-Gen and RSS-247 limits.

The external I/O cables were draped along the test table and formed a bundle 30 to 40 cm long in the middle.

EMI Test Receiver & Spectrum Analyzer Setup

The system was investigated from 9 kHz to 25 GHz.

During the radiated emission test, the EMI test receiver & Spectrum Analyzer Setup were set with the following configurations:

9 kHz-1GHz:

Frequency Range	RBW	Video B/W	IF B/W	Measurement
9 kHz – 150 kHz	/	/	200 Hz	QP
	300 Hz	1 kHz	/	PK
150 kHz – 30 MHz	/	/	9 kHz	QP
	10 kHz	30 kHz	/	PK
30 MHz – 1000 MHz	/	/	120 kHz	QP
	100 kHz	300 kHz	/	PK

1-25 GHz:

Measurement	Duty cycle	RBW	Video B/W
PK	Any	1MHz	3 MHz
AV	>98%	1MHz	10 Hz
	<98%	1MHz	≥1/Ton

Note: Ton is minimum transmission duration

If the maximized peak measured value complies with under the QP/Average limit more than 6dB, then it is unnecessary to perform an QP/Average measurement.

Test Procedure

Maximizing procedure was performed on the highest emissions to ensure that the EUT complied with all installation combinations.

All final data was recorded in Quasi-peak detection mode except for the frequency bands 9–90 kHz, 110–490 kHz and above 1000 MHz, average detection modes for frequency bands 9–90 kHz and 110–490 kHz, peak and average detection modes for frequencies above 1 GHz.

For 9 kHz-30MHz, the report shall list the six emissions with the smallest margin relative to the limit, for each of the three antenna orientations (parallel, perpendicular, and ground-parallel) unless the margin is greater than 20 dB.

All emissions under the average limit and under the noise floor have not recorded in the report.

Factor & Over Limit/ Margin Calculation

The Factor is calculated by adding the Antenna Factor and Cable Loss, and subtracting the Amplifier Gain. The basic equation is as follows:

$$\text{Factor} = \text{Antenna Factor} + \text{Cable Loss} - \text{Amplifier Gain}$$

The “**Over Limit/Margin**” column of the following data tables indicates the degree of compliance with the applicable limit. For example, an Over Limit/margin of -7dB means the emission is 7dB below the limit. The equation for calculation is as follows:

$$\begin{aligned} \text{Over Limit/Margin} &= \text{Level} / \text{Corrected Amplitude} - \text{Limit} \\ \text{Level} / \text{Corrected Amplitude} &= \text{Read Level} + \text{Factor} \end{aligned}$$

Test Results Summary

According to the data in the following table, the EUT complied with the FCC 15.205, FCC 15.209, FCC 15.247, RSS-Gen and RSS-247.

Test Data

Environmental Conditions

Temperature:	22~25.6 °C
Relative Humidity:	50~54%
ATM Pressure:	101 kPa

The testing was performed by Anson Su on 2024-07-19 for below 1GHz and Sadow Tan from 2024-07-15 to 2024-08-05 for above 1GHz.

EUT operation mode: Transmitting

Note: Pre-scan in the X, Y and Z axes of orientation, the worst case z-axis of orientation was recorded;

Note: for below 1GHz range, according to the test result of BT report, the adapter 1 was worst case, so the worst case adapter 1 was tested in this report.

Note: for below 1GHz range, the POE power mode was evaluated under the worst case mode(5G wifi) according to the result of adapter, it was verified POE power mode compliance with requirement, so the POE mode not performed in this report.

9 kHz-30MHz: *(maximum output power mode BLE 1M, Low Channel)*

The amplitude of spurious emissions attenuated more than 20 dB below the limit was not recorded.

30MHz-1GHz: (maximum output power mode BLE 1M, Low Channel)

For Model: V62W

Horizontal

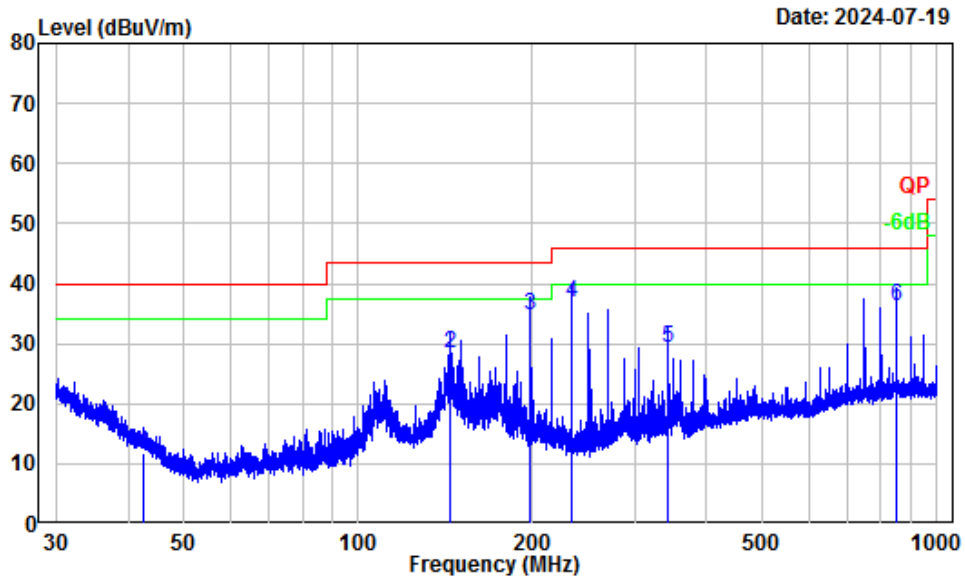

Site : Chamber A
 Condition : 3m Horizontal
 Project Number: 2401U79863E-RF
 Test Mode : BLE
 Tester : Anson Su

	Freq	Factor	Read Level	Read Level	Limit Line	Over Limit	Remark
	MHz	dB/m	dBuV	dBuV/m	dBuV/m	dB	
1	42.54	-13.14	25.00	11.86	40.00	-28.14	QP
2	144.02	-13.03	41.30	28.27	43.50	-15.23	QP
3	197.98	-13.73	48.48	34.75	43.50	-8.75	QP
4	233.96	-14.20	50.91	36.71	46.00	-9.29	QP
5	341.98	-12.11	41.29	29.18	46.00	-16.82	QP
6	850.29	-4.82	41.14	36.32	46.00	-9.68	QP

Vertical

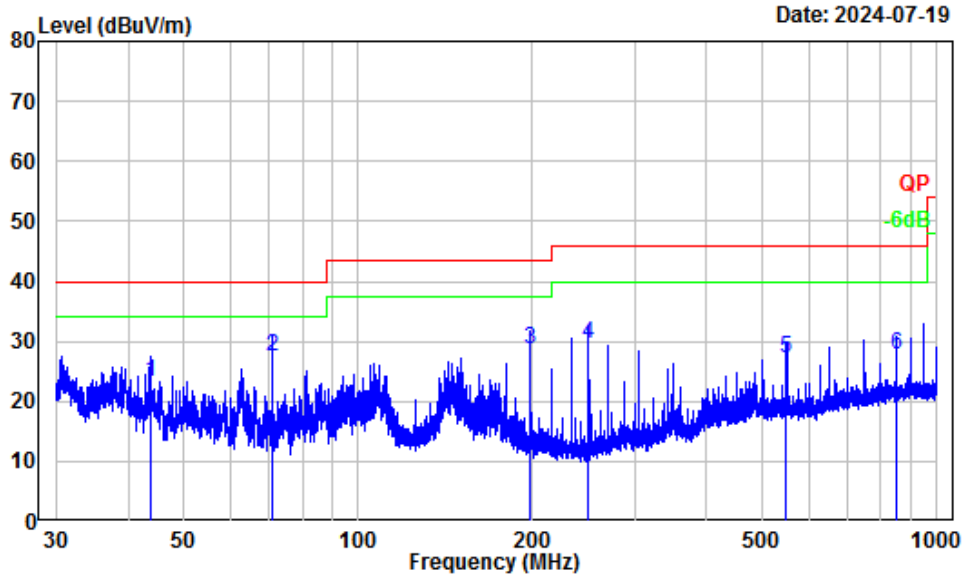

Site : Chamber A
 Condition : 3m Vertical
 Project Number: 2401U79863E-RF
 Test Mode : BLE
 Tester : Anson Su

	Freq	Factor	Read Level	Level	Limit Line	Over Limit	Remark
	MHz	dB/m	dBuV	dBuV/m	dBuV/m	dB	
1	43.81	-15.17	38.47	23.30	40.00	-16.70	QP
2	71.08	-18.66	46.19	27.53	40.00	-12.47	QP
3	197.98	-14.81	43.49	28.68	43.50	-14.82	QP
4	249.97	-14.93	44.47	29.54	46.00	-16.46	QP
5	549.98	-8.26	35.32	27.06	46.00	-18.94	QP
6	850.29	-5.12	32.78	27.66	46.00	-18.34	QP

For Model: V61W

Horizontal

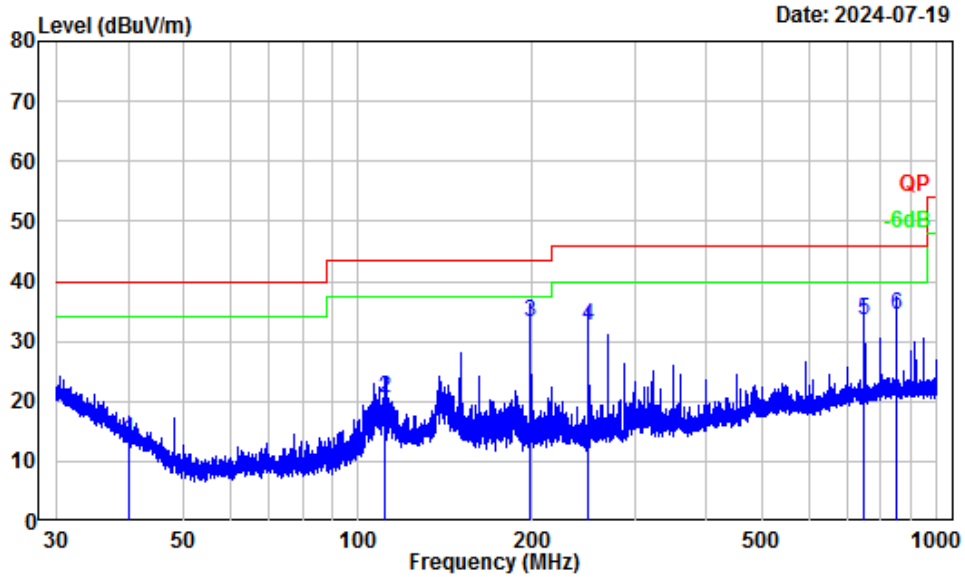

Site : Chamber A
 Condition : 3m Horizontal
 Project Number: 2401U79863E-RF
 Test Mode : BLE
 Tester : Anson Su

	Freq	Factor	Read Level	Level	Limit Line	Over Limit	Remark
	MHz	dB/m	dBuV	dBuV/m	dBuV/m	dB	
1	40.21	-11.65	25.17	13.52	40.00	-26.48	QP
2	110.81	-13.01	33.60	20.59	43.50	-22.91	QP
3	197.98	-13.73	46.79	33.06	43.50	-10.44	QP
4	249.97	-14.53	47.03	32.50	46.00	-13.50	QP
5	750.11	-5.54	38.90	33.36	46.00	-12.64	QP
6	850.29	-4.82	39.21	34.39	46.00	-11.61	QP

Vertical

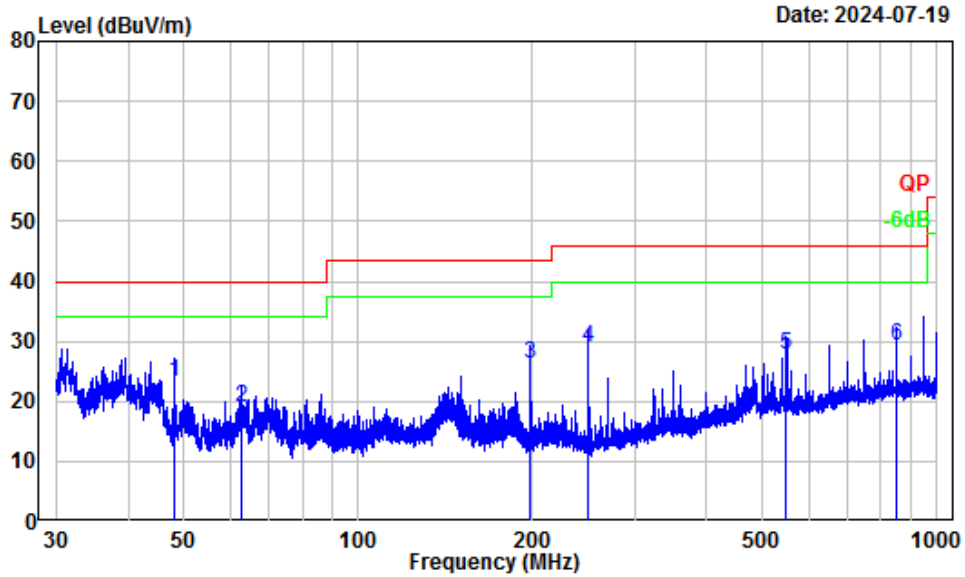

Site : Chamber A
 Condition : 3m Vertical
 Project Number: 2401U79863E-RF
 Test Mode : BLE
 Tester : Anson Su

	Freq	Factor	Read Level	Level	Limit Line	Over Limit	Remark
	MHz	dB/m	dBuV	dBuV/m	dBuV/m	dB	
1	47.99	-17.51	40.79	23.28	40.00	-16.72	QP
2	62.76	-18.80	37.75	18.95	40.00	-21.05	QP
3	197.98	-14.81	41.11	26.30	43.50	-17.20	QP
4	249.97	-14.93	43.85	28.92	46.00	-17.08	QP
5	549.98	-8.26	36.12	27.86	46.00	-18.14	QP
6	850.29	-5.12	34.38	29.26	46.00	-16.74	QP

1-25 GHz: (model V62W was tested)

Frequency (MHz)	Receiver		Polar (H/V)	Factor (dB/m)	Corrected Amplitude (dBμV/m)	Limit (dBμV/m)	Margin (dB)
	Reading (dBμV)	PK/AV					
BLE 1M							
Low Channel 2402MHz							
2339.93	45.41	PK	H	-3.03	42.38	74	-31.62
2339.93	40.23	AV	H	-3.03	37.20	54	-16.80
2388.09	45.65	PK	V	-2.93	42.72	74	-31.28
2388.09	40.28	AV	V	-2.93	37.35	54	-16.65
4804.00	56.36	PK	H	1.69	58.05	74	-15.95
4804.00	51.12	AV	H	1.69	52.81	54	-1.19
4804.00	54.14	PK	V	1.69	55.83	74	-18.17
4804.00	49.87	AV	V	1.69	51.56	54	-2.44
Middle Channel 2440MHz							
4880.00	54.67	PK	H	1.69	56.36	74	-17.64
4880.00	49.67	AV	H	1.69	51.36	54	-2.64
4880.00	53.85	PK	V	1.69	55.54	74	-18.46
4880.00	48.62	AV	V	1.69	50.31	54	-3.69
High Channel 2480MHz							
2483.51	54.66	PK	H	-3.17	51.49	74	-22.51
2483.51	41.91	AV	H	-3.17	38.74	54	-15.26
2495.49	57.21	PK	V	-3.19	54.02	74	-19.98
2495.49	47.62	AV	V	-3.19	44.43	54	-9.57
4960.00	51.84	PK	H	2.77	54.61	74	-19.39
4960.00	46.76	AV	H	2.77	49.53	54	-4.47
4960.00	51.22	PK	V	2.77	53.99	74	-20.01
4960.00	45.89	AV	V	2.77	48.66	54	-5.34

Frequency (MHz)	Receiver		Polar (H/V)	Factor (dB/m)	Corrected Amplitude (dBμV/m)	Limit (dBμV/m)	Margin (dB)
	Reading (dBμV)	PK/AV					
BLE 2M							
Low Channel 2402MHz							
2317.24	54.33	PK	H	-3.03	51.30	74	-22.70
2317.24	39.97	AV	H	-3.03	36.94	54	-17.06
2367.25	53.99	PK	V	-2.93	51.06	74	-22.94
2367.25	40.18	AV	V	-2.93	37.25	54	-16.75
4804.00	56.11	PK	H	1.69	57.80	74	-16.20
4804.00	48.54	AV	H	1.69	50.23	54	-3.77
4804.00	54.03	PK	V	1.69	55.72	74	-18.28
4804.00	45.63	AV	V	1.69	47.32	54	-6.68
Middle Channel 2440MHz							
4880.00	53.29	PK	H	1.69	54.98	74	-19.02
4880.00	44.57	AV	H	1.69	46.26	54	-7.74
4880.00	51.16	PK	V	1.69	52.85	74	-21.15
4880.00	41.17	AV	V	1.69	42.86	54	-11.14
High Channel 2480MHz							
2483.58	54.52	PK	H	-3.17	51.35	74	-22.65
2483.58	47.25	AV	H	-3.17	44.08	54	-9.92
2490.64	53.74	PK	V	-3.18	50.56	74	-23.44
2490.64	40.65	AV	V	-3.18	37.47	54	-16.53
4960.00	49.99	PK	H	2.77	52.76	74	-21.24
4960.00	39.63	AV	H	2.77	42.40	54	-11.60
4960.00	48.61	PK	V	2.77	51.38	74	-22.62
4960.00	39.09	AV	V	2.77	41.86	54	-12.14

Note:

Corrected Factor = Antenna factor (RX) + Cable Loss – Amplifier Factor

Corrected Amplitude = Corrected Factor + Reading

Margin = Corrected. Amplitude - Limit

The other spurious emission which is in the noise floor level was not recorded.

Test plots for Band Edge Measurements (Radiated):

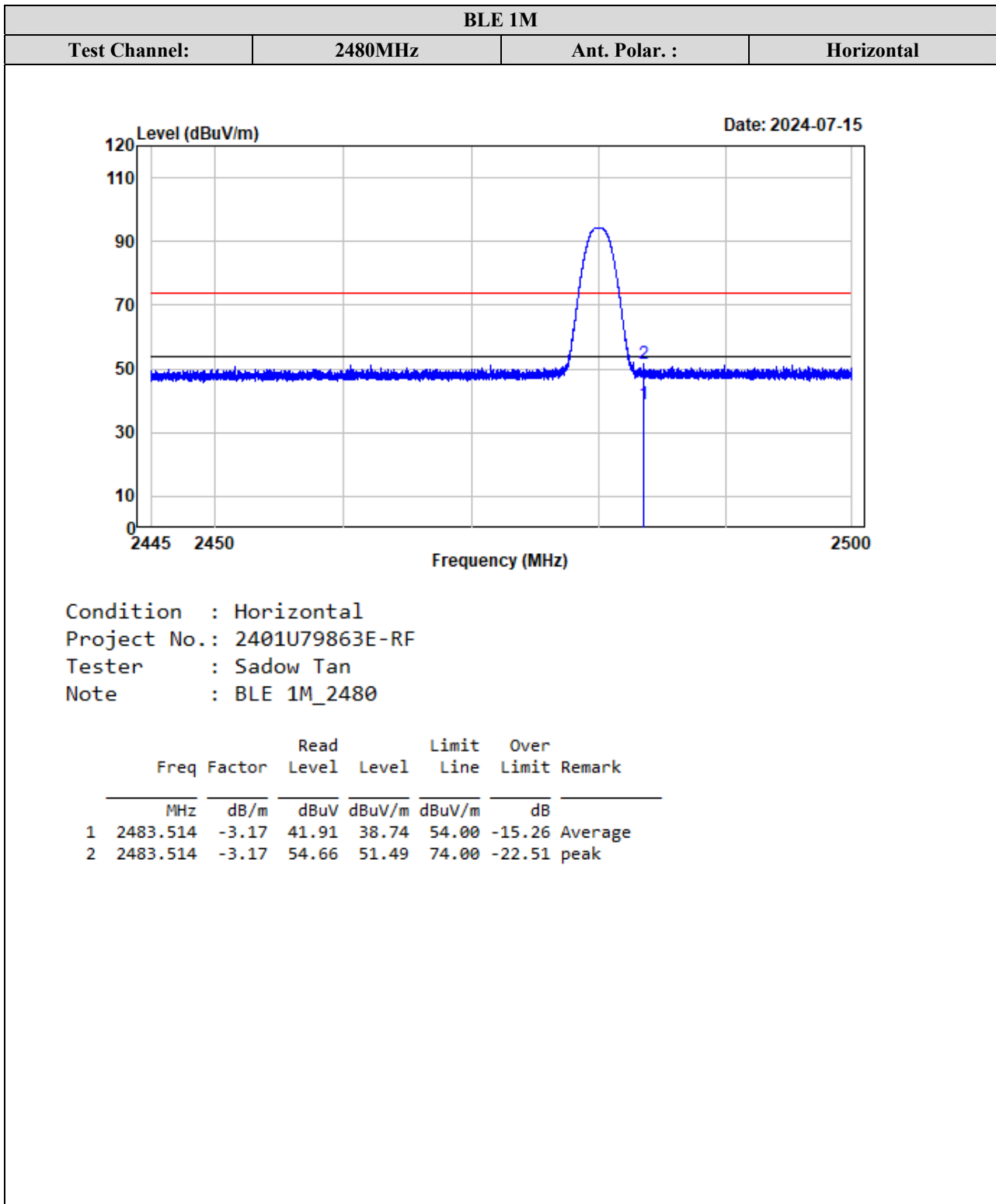

BLE 1M			
Test Channel:	2480MHz	Ant. Polar. :	Vertical

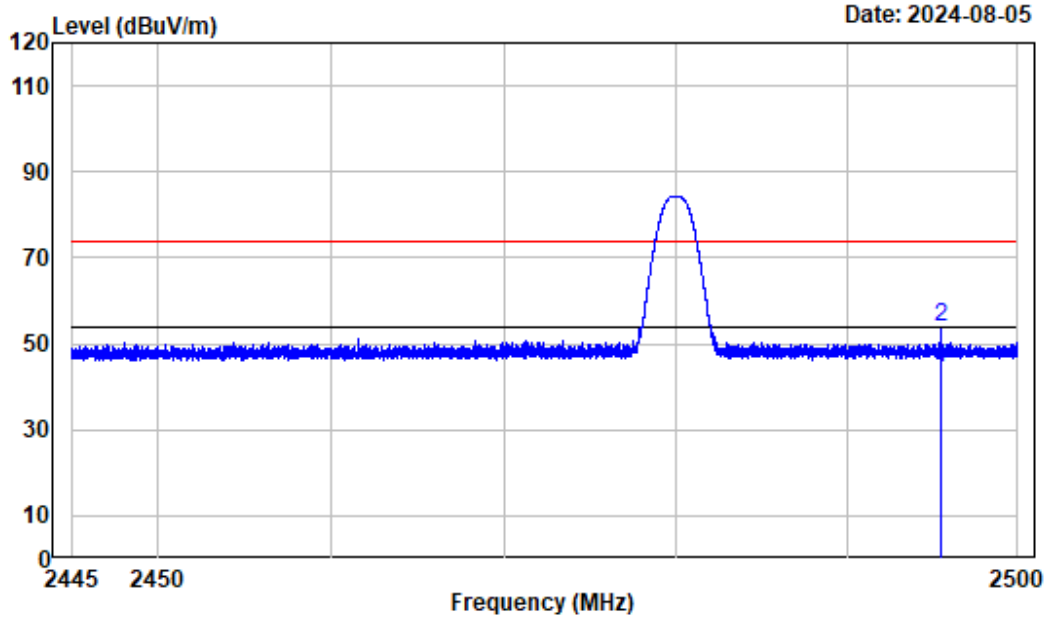

Condition : Vertical
 Project No.: 2401U79863E-RF
 Tester : Sadow Tan
 Note : BLE 1M_2480

	Freq	Factor	Read Level	Level	Limit Line	Over Limit	Remark
	MHz	dB/m	dBuV	dBuV/m	dBuV/m	dB	
1	2495.490	-3.19	47.62	44.43	54.00	-9.57	Average
2	2495.490	-3.19	57.21	54.02	74.00	-19.98	peak

BLE 2M			
Test Channel:	2480MHz	Ant. Polar. :	Horizontal

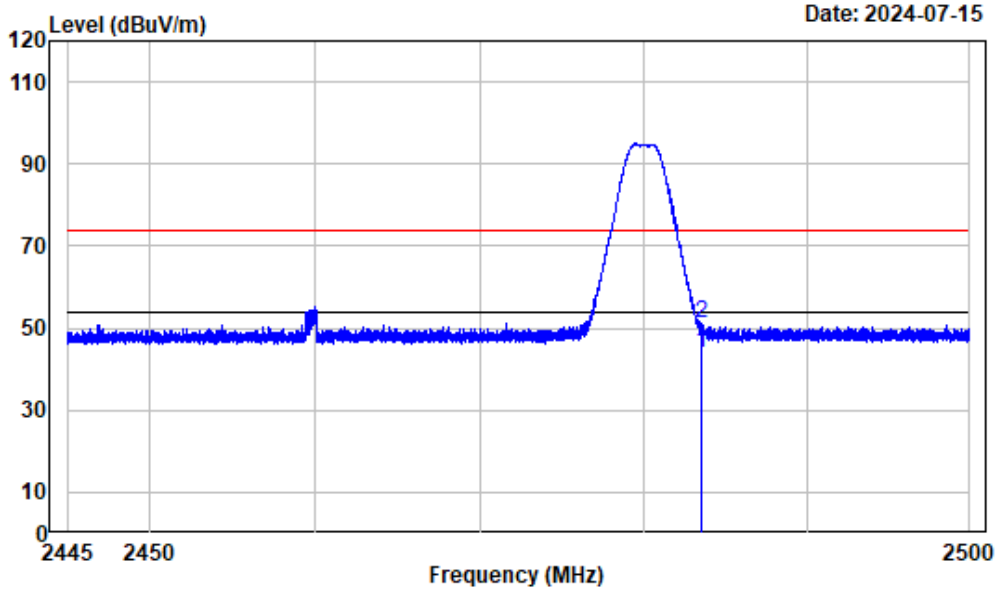

Condition : Horizontal
 Project No.: 2401U79863E-RF
 Tester : Sadow Tan
 Note : BLE 2M_2480

	Freq	Factor	Read Level	Level	Limit	Over Limit	Remark
	MHz	dB/m	dBuV	dBuV/m	dBuV/m	dB	
1	2483.576	-3.17	47.25	44.08	54.00	-9.92	Average
2	2483.576	-3.17	54.52	51.35	74.00	-22.65	peak

BLE 2M			
Test Channel:	2480MHz	Ant. Polar. :	Vertical

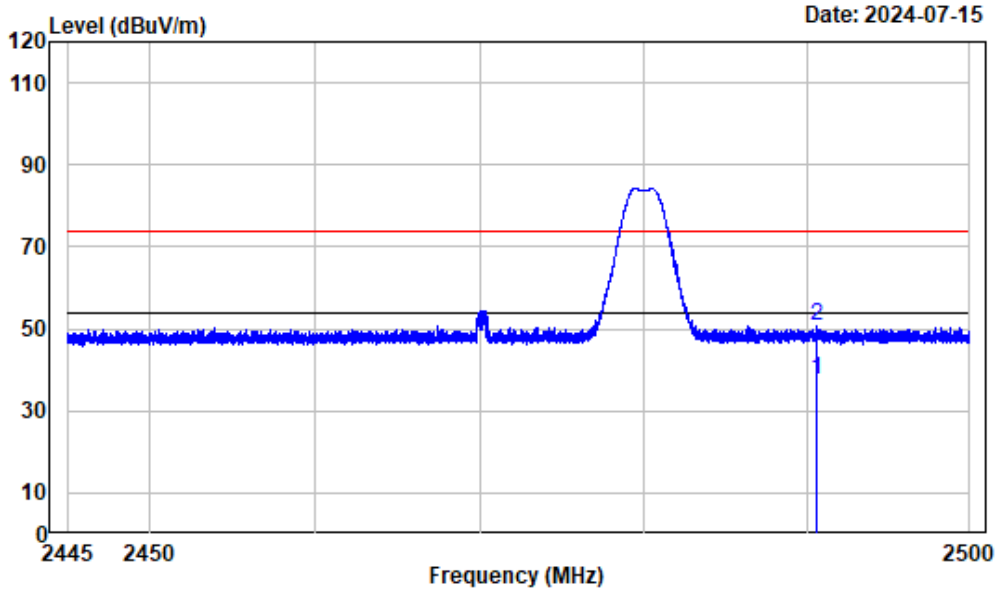

Condition : Vertical
 Project No.: 2401U79863E-RF
 Tester : Sadow Tan
 Note : BLE 2M_2480

	Freq	Factor	Read Level	Level	Limit Line	Over Limit	Remark
	MHz	dB/m	dBuV	dBuV/m	dBuV/m	dB	
1	2490.636	-3.18	40.65	37.47	54.00	-16.53	Average
2	2490.636	-3.18	53.74	50.56	74.00	-23.44	peak

Test plots for Harmonic Measurements:

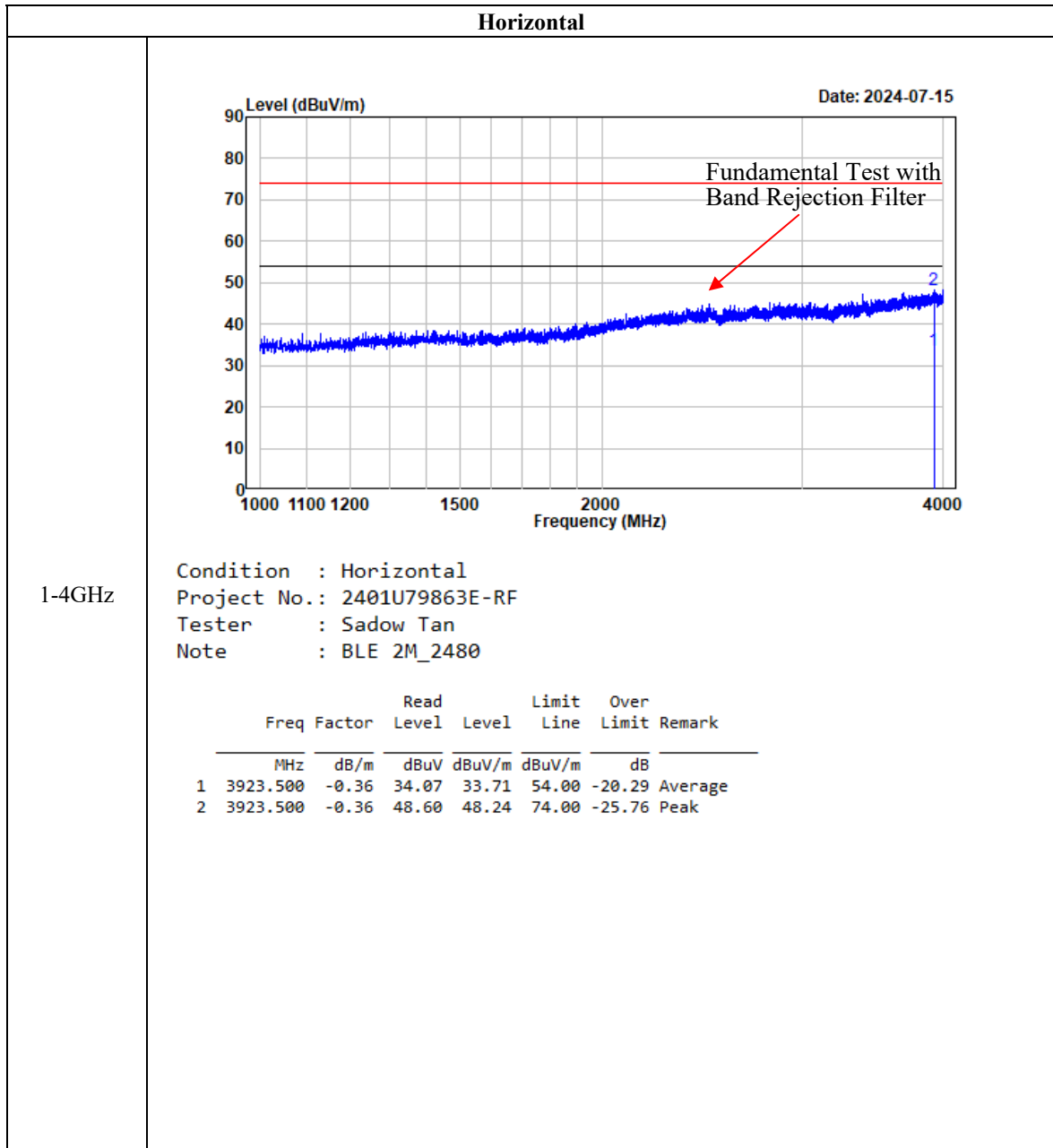

Vertical

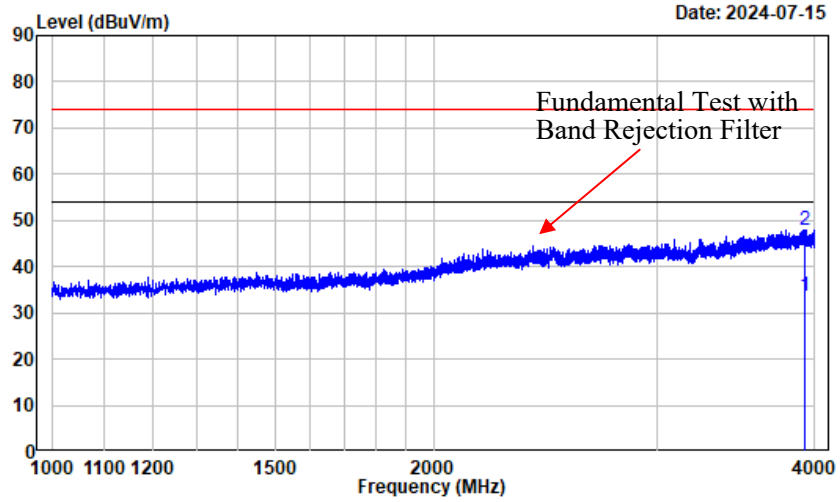

1-4GHz

Condition : Vertical
 Project No.: 2401U79863E-RF
 Tester : Sadow Tan
 Note : BLE 2M_2480

	Freq	Factor	Read Level	Level	Limit Line	Over Limit	Remark
	MHz	dB/m	dBuV	dBuV/m	dBuV/m	dB	
1	3930.625	-0.31	33.86	33.55	54.00	-20.45	Average
2	3930.625	-0.31	48.35	48.04	74.00	-25.96	Peak

Horizontal

4-18GHz

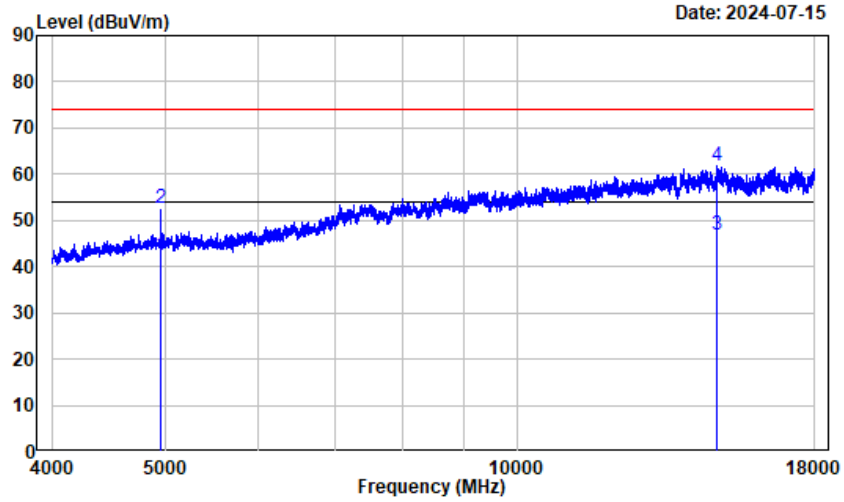

Condition : Horizontal
 Project No.: 2401U79863E-RF
 Tester : Sadow Tan
 Note : BLE 2M_2480

	Freq	Factor	Read Level	Level	Limit Line	Over Limit	Remark
	MHz	dB/m	dBuV	dBuV/m	dBuV/m	dB	
1	4960.000	2.77	39.63	42.40	54.00	-11.60	Average
2	4960.000	2.77	49.99	52.76	74.00	-21.24	Peak
3	14850.000	16.75	30.19	46.94	54.00	-7.06	Average
4	14850.000	16.75	45.21	61.96	74.00	-12.04	Peak

Vertical

4-18GHz

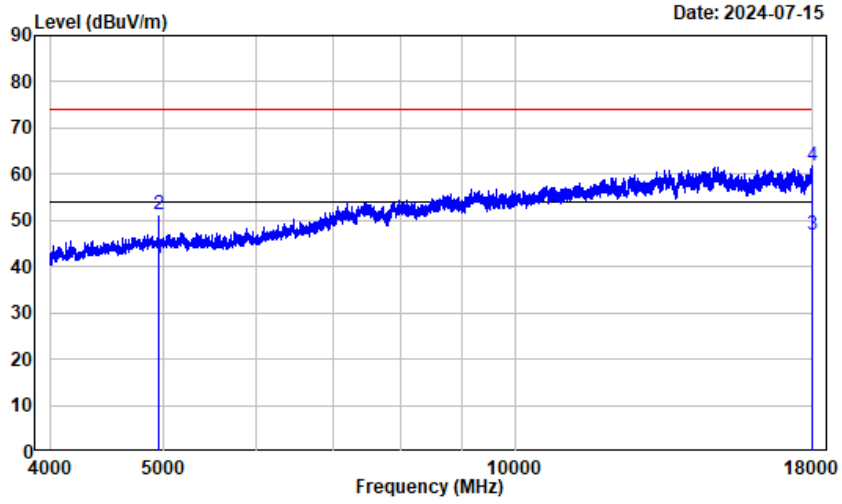

Condition : Vertical
 Project No.: 2401U79863E-RF
 Tester : Sadow Tan
 Note : BLE 2M_2480

	Freq	Factor	Read Level	Level	Limit Line	Over Limit	Remark
	MHz	dB/m	dBuV	dBuV/m	dBuV/m	dB	
1	4960.000	2.77	39.09	41.86	54.00	-12.14	Average
2	4960.000	2.77	48.61	51.38	74.00	-22.62	Peak
3	17986.000	24.52	22.48	47.00	54.00	-7.00	Average
4	17986.000	24.52	37.19	61.71	74.00	-12.29	Peak

Horizontal

18-25GHz

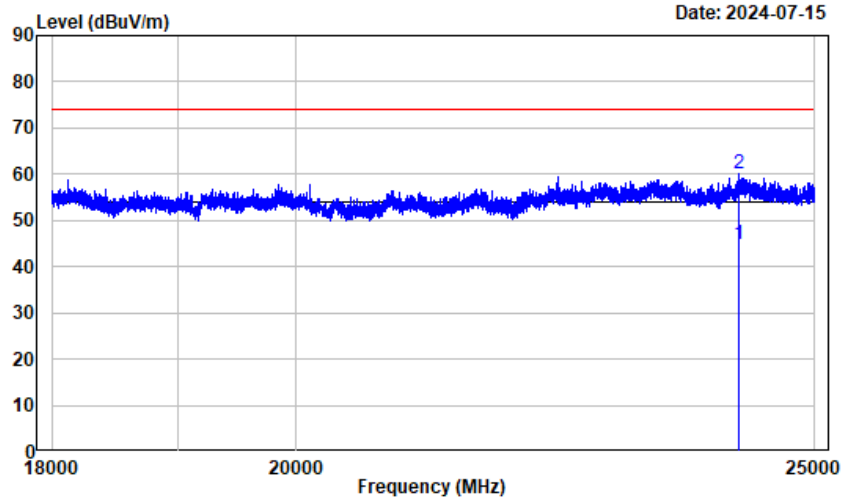

Condition : Horizontal
 Project No.: 2401U79863E-RF
 Tester : Sadow Tan
 Note : BLE 2M_2480

	Freq	Factor	Read Level	Level	Limit Line	Over Limit	Remark
	MHz	dB/m	dBuV	dBuV/m	dBuV/m	dB	
1	24203.750	18.29	26.67	44.96	54.00	-9.04	Average
2	24203.750	18.29	41.88	60.17	74.00	-13.83	peak

Vertical

18-25GHz

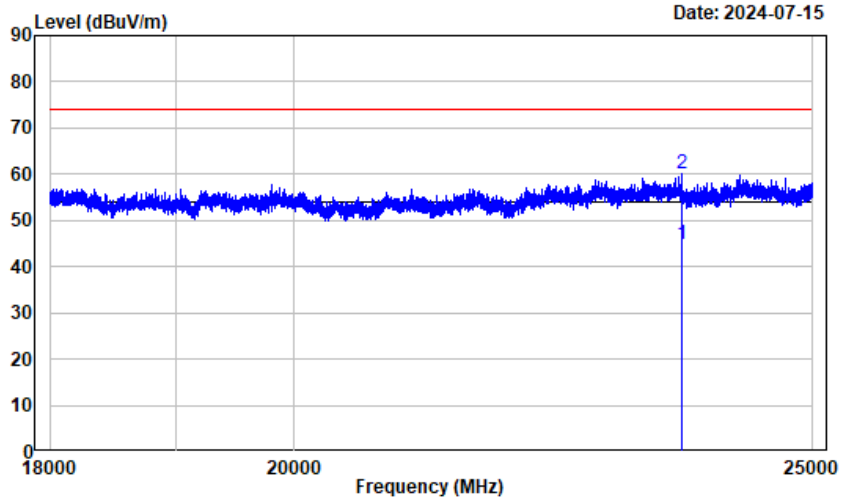

Condition : Vertical
 Project No.: 2401U79863E-RF
 Tester : Sadow Tan
 Note : BLE 2M_2480

	Read	Limit	Over				
Freq	Factor	Level	Level	Line			
MHz	dB/m	dBuV	dBuV/m	dBuV/m			
1	23631.500	17.55	27.42	44.97	54.00	-9.03	Average
2	23631.500	17.55	42.49	60.04	74.00	-13.96	peak

FCC §15.247(a) (2), RSS-GEN § 6.7 & RSS-247 § 5.2 (a) - 99% OCCUPIED BANDWIDTH & 6 dB EMISSION BANDWIDTH

Standard Applicable

According to FCC §15.247(a) (2)

Systems using digital modulation techniques may operate in the 902–928 MHz, 2400–2483.5 MHz, and 5725–5850 MHz bands. The minimum 6 dB bandwidth shall be at least 500 kHz.

According to RSS-247 §5.2 a)

The minimum 6 dB bandwidth shall be 500 kHz.

According to RSS-Gen §6.7

The occupied bandwidth or the “99% emission bandwidth” is defined as the frequency range between two points, one above and the other below the carrier frequency, within which 99% of the total transmitted power of the fundamental transmitted emission is contained. The occupied bandwidth shall be reported for all equipment in addition to the specified bandwidth required in the applicable RSSs.

In some cases, the “x dB bandwidth” is required, which is defined as the frequency range between two points, one at the lowest frequency below and one at the highest frequency above the carrier frequency, at which the maximum power level of the transmitted emission is attenuated x dB below the maximum in-band power level of the modulated signal, where the two points are on the outskirts of the in-band emission.

The following conditions shall be observed for measuring the occupied bandwidth and x dB bandwidth:

- The transmitter shall be operated at its maximum carrier power measured under normal test conditions.
- The span of the spectrum analyzer shall be set large enough to capture all products of the modulation process, including the emission skirts, around the carrier frequency, but small enough to avoid having other emissions (e.g. on adjacent channels) within the span.
- The detector of the spectrum analyzer shall be set to “Sample”. However, a peak, or peak hold, may be used in place of the sampling detector since this usually produces a wider bandwidth than the actual bandwidth (worst-case measurement). Use of a peak hold (or “Max Hold”) may be necessary to determine the occupied / x dB bandwidth if the device is not transmitting continuously.
- The resolution bandwidth (RBW) shall be in the range of 1% to 5% of the actual occupied / x dB bandwidth and the video bandwidth (VBW) shall not be smaller than three times the RBW value. Video averaging is not permitted.

Note: It may be necessary to repeat the measurement a few times until the RBW and VBW are in compliance with the above requirement.

For the 99% emission bandwidth, the trace data points are recovered and directly summed in linear power level terms. The recovered amplitude data points, beginning at the lowest frequency, are placed in a running sum until 0.5% of the total is reached, and that frequency recorded. The process is repeated for the highest frequency data points (starting at the highest frequency, at the right side of the span, and going down in frequency). This frequency is then recorded. The difference between the two recorded frequencies is the occupied bandwidth (or the 99% emission bandwidth).

Test Procedure

Test Method: ANSI C63.10-2013 Clause 11.8.1 & Clause 6.9.3& RSS-Gen §6.7

- a. Set RBW = 100 kHz.
- b. Set the VBW $\geq [3 \times \text{RBW}]$.
- c. Detector = peak.
- d. Trace mode = max hold.
- e. Sweep = auto couple.
- f. Allow the trace to stabilize.
- g. Measure the maximum width of the emission that is constrained by the frequencies associated with the two outermost amplitude points (upper and lower frequencies) that are attenuated by 6 dB relative to the maximum level measured in the fundamental emission.

The occupied bandwidth is the frequency bandwidth such that, below its lower and above its upper frequency limits, the mean powers are each equal to 0.5% of the total mean power of the given emission. Procedure as below

- a. The instrument center frequency is set to the nominal EUT channel center frequency. The frequency span for the spectrum analyzer shall be between 1.5 times and 5.0 times the OBW.
- b. The nominal IF filter bandwidth (3 dB RBW) shall be in the range of 1% to 5% of the OBW, and VBW shall be approximately three times the RBW (for RSS rules, VBW shall not be smaller than three times the RBW, unless otherwise specified by the applicable requirement).
- c. Set the reference level of the instrument as required, keeping the signal from exceeding the maximum input mixer level for linear operation. In general, the peak of the spectral envelope shall be more than $[10 \log (\text{OBW}/\text{RBW})]$ below the reference level.
- d. Step a) through step c) might require iteration to adjust within the specified range.
- e. Video averaging is not permitted. Where practical, a sample detection and single sweep mode shall be used. Otherwise, peak detection and max hold mode (until the trace stabilizes) shall be used.
- f. Use the 99% power bandwidth function of the instrument (if available) and report the measured bandwidth.
- g. If the instrument does not have a 99% power bandwidth function, then the trace data points are recovered and directly summed in linear power terms. The recovered amplitude data points, beginning at the lowest frequency, are placed in a running sum until 0.5% of the total is reached; that frequency is recorded as the lower frequency. The process is repeated until 99.5% of the total is reached; that frequency is recorded as the upper frequency. The 99% power bandwidth is the difference between these two frequencies.
- h. The occupied bandwidth shall be reported by providing plot(s) of the measuring instrument display; the plot axes and the scale units per division shall be clearly labeled. Tabular data maybe reported in addition to the plot(s).

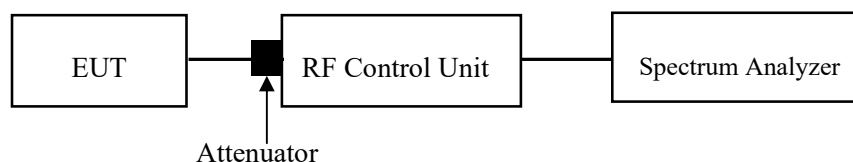

Test Data

Environmental Conditions

Temperature:	24 °C
Relative Humidity:	48 %
ATM Pressure:	101 kPa

The testing was performed by Navilite Cai on 2024-07-12.

EUT operation mode: Transmitting

Test Result: Compliant. Please refer to the Appendix.

FCC §15.247(b) (3), RSS-247 §5.4 (d) - PEAK OUTPUT POWER MEASUREMENT

Applicable Standard

According to FCC §15.247(b) (3), for systems using digital modulation in the 902-928 MHz, 2400-2483.5 MHz, and 5725-5850 MHz bands: 1 Watt. As an alternative to a peak power measurement, compliance with the one Watt limit can be based on a measurement of the maximum conducted output power. Maximum Conducted Output Power is defined as the total transmit power delivered to all antennas and antenna elements averaged across all symbols in the signaling alphabet when the transmitter is operating at its maximum power control level. Power must be summed across all antennas and antenna elements. The average must not include any time intervals during which the transmitter is off or is transmitting at a reduced power level. If multiple modes of operation are possible (e.g., alternative modulation methods), the maximum conducted output power is the highest total transmit power occurring in any mode.

According to RSS-247§5.4 d) For DTSs employing digital modulation techniques operating in the bands 902-928 MHz and 2400-2483.5 MHz, the maximum peak conducted output power shall not exceed 1 W. Except as provided in Section 5.4(e), the e.i.r.p. shall not exceed 4 W.

As an alternative to a peak power measurement, compliance can be based on a measurement of the maximum conducted output power. The maximum conducted output power is the total transmit power delivered to all antennas and antenna elements, averaged across all symbols in the signalling alphabet when the transmitter is operating at its maximum power control level. Power must be summed across all antennas and antenna elements. The average must not include any time intervals during which the transmitter is off or transmitting at a reduced power level. If multiple modes of operation are implemented, the maximum conducted output power is the highest total transmit power occurring in any mode.

Test Procedure

Test Method: ANSI C63.10-2013 Clause 11.9.1.1

1. Place the EUT on a bench and set it in transmitting mode.
2. Remove the antenna from the EUT and then connect a low loss RF cable from the antenna port to one test equipment.
3. Add a correction factor to the display.
4. Set the RBW \geq DTS bandwidth.
5. Set the VBW \geq $[3 \times \text{RBW}]$.
6. Set span \geq $[3 \times \text{RBW}]$.
7. Sweep time = auto couple.
8. Detector = peak.
9. Trace mode = max hold.
10. Allow the trace to stabilize.
11. Use peak marker function to determine the peak amplitude level.

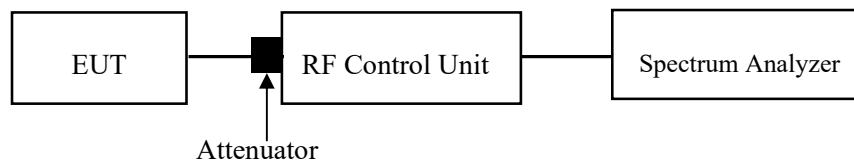

Test Data**Environmental Conditions**

Temperature:	24 °C
Relative Humidity:	48 %
ATM Pressure:	101 kPa

The testing was performed by Navilite Cai on 2024-07-12.

EUT operation mode: Transmitting

Test Result: Compliant. Please refer to the Appendix.

FCC §15.247(e), RSS-247 §5.2 (b) – POWER SPECTRAL DENSITY

Applicable Standard

According to FCC §15.247(e):

For digitally modulated systems, the power spectral density conducted from the intentional radiator to the antenna shall not be greater than 8 dBm in any 3 kHz band during any time interval of continuous transmission. This power spectral density shall be determined in accordance with the provisions of paragraph (b) of this section. The same method of determining the conducted output power shall be used to determine the power spectral density.

According to RSS-247 §5.2 b):

The transmitter power spectral density conducted from the transmitter to the antenna shall not be greater than 8 dBm in any 3 kHz band during any time interval of continuous transmission. This power spectral density shall be determined in accordance with the provisions of section 5.4(d), (i.e. the power spectral density shall be determined using the same method as is used to determine the conducted output power)

Test Procedure

Test Method: ANSI C63.10-2013 Clause 11.10.2

1. Use this procedure when the maximum peak conducted output power in the fundamental emission is used to demonstrate compliance.
2. Set analyzer center frequency to DTS channel center frequency
3. Set the span to 1.5 times the DTS bandwidth.
4. Set the RBW to: $3\text{kHz} \leq \text{RBW} \leq 100\text{ kHz}$.
5. Set the VBW $\geq 3 \times \text{RBW}$.
6. Detector = peak.
7. Sweep time = auto couple.
8. Trace mode = max hold.
9. Allow trace to fully stabilize.
10. Use the peak marker function to determine the maximum amplitude level within the RBW.
11. If measured value exceeds limit, reduce RBW (no less than 3 kHz) and repeat.

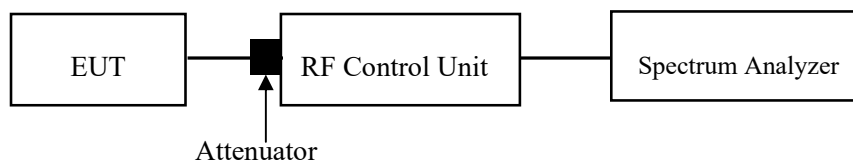

Test Data**Environmental Conditions**

Temperature:	24 °C
Relative Humidity:	48 %
ATM Pressure:	101 kPa

The testing was performed by Navilite Cai on 2024-07-12.

Test Mode: Transmitting

Test Result: Compliant. Please refer to the Appendix.

FCC §15.247(d) & RSS-247 §5.5 - 100 kHz BANDWIDTH OF FREQUENCY BAND EDGE

Applicable Standard

In any 100 kHz bandwidth outside the frequency band in which the spread spectrum or digitally modulated intentional radiator is operating, the radio frequency power that is produced by the intentional radiator shall be at least 20 dB below that in the 100 kHz bandwidth within the band that contains the highest level of the desired power, based on either an RF conducted or a radiated measurement, provided the transmitter demonstrates compliance with the peak conducted power limits. If the transmitter complies with the conducted power limits based on the use of RMS averaging over a time interval, as permitted under paragraph (b)(3) of this section, the attenuation required under this paragraph shall be 30 dB instead of 20 dB. Attenuation below the general limits specified in §15.209(a) is not required. In addition, radiated emissions which fall in the restricted bands, as defined in §15.205(a), must also comply with the radiated emission limits specified in §15.209(a) (see §15.205(c)).

In any 100 kHz bandwidth outside the frequency band in which the spread spectrum or digitally modulated device is operating, the RF power that is produced shall be at least 20 dB below that in the 100 kHz bandwidth within the band that contains the highest level of the desired power, based on either an RF conducted or a radiated measurement, provided that the transmitter demonstrates compliance with the peak conducted power limits. If the transmitter complies with the conducted power limits based on the use of root-mean-square averaging over a time interval, as permitted under section 5.4(d), the attenuation required shall be 30 dB instead of 20 dB. Attenuation below the general field strength limits specified in RSS-Gen is not required

Test Procedure

Test Method: ANSI C63.10-2013 Clause 11.11

1. Set the RBW =100 kHz.
2. Set the VBW $\geq 3 \times$ RBW.
3. Detector = peak
4. Sweep time = auto couple.
5. Trace mode=max hold
6. All trace to fully stabilize
7. Use the peak marker function to determine the maximum amplitude level.

Ensure that amplitude of all unwanted emissions outside of the authorized frequency band(excluding restricted frequency bands) is attenuated by at least the minimum requirement specified in 11.11.

Report the three highest emissions relative to the limit.

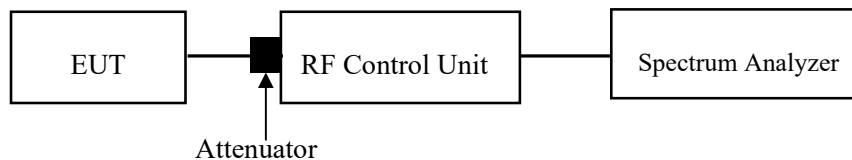

Test Data**Environmental Conditions**

Temperature:	24 °C
Relative Humidity:	48 %
ATM Pressure:	101 kPa

The testing was performed by Navilite Cai on 2024-07-12.

EUT operation mode: Transmitting

Test Result: Compliant. Please refer to the Appendix.

EUT PHOTOGRAPHS

Please refer to the attachment 2401U79863E-RF External photo and 2401U79863E-RF Internal photo.

TEST SETUP PHOTOGRAPHS

Please refer to the attachment 2401U79863E-RFA Test Setup photo.

APPENDIX**Appendix A: DTS Bandwidth****Test Result**

Test Mode	Antenna	Frequency[MHz]	DTS BW [MHz]	FL[MHz]	FH[MHz]	Limit[MHz]	Verdict
BLE_1M	Ant1	2402	0.66	2401.66	2402.33	0.5	PASS
		2440	0.66	2439.66	2440.33	0.5	PASS
		2480	0.66	2479.66	2480.33	0.5	PASS
BLE_2M	Ant1	2402	1.24	2401.35	2402.59	0.5	PASS
		2440	1.24	2439.34	2440.59	0.5	PASS
		2480	1.24	2479.34	2480.59	0.5	PASS

Test Graphs

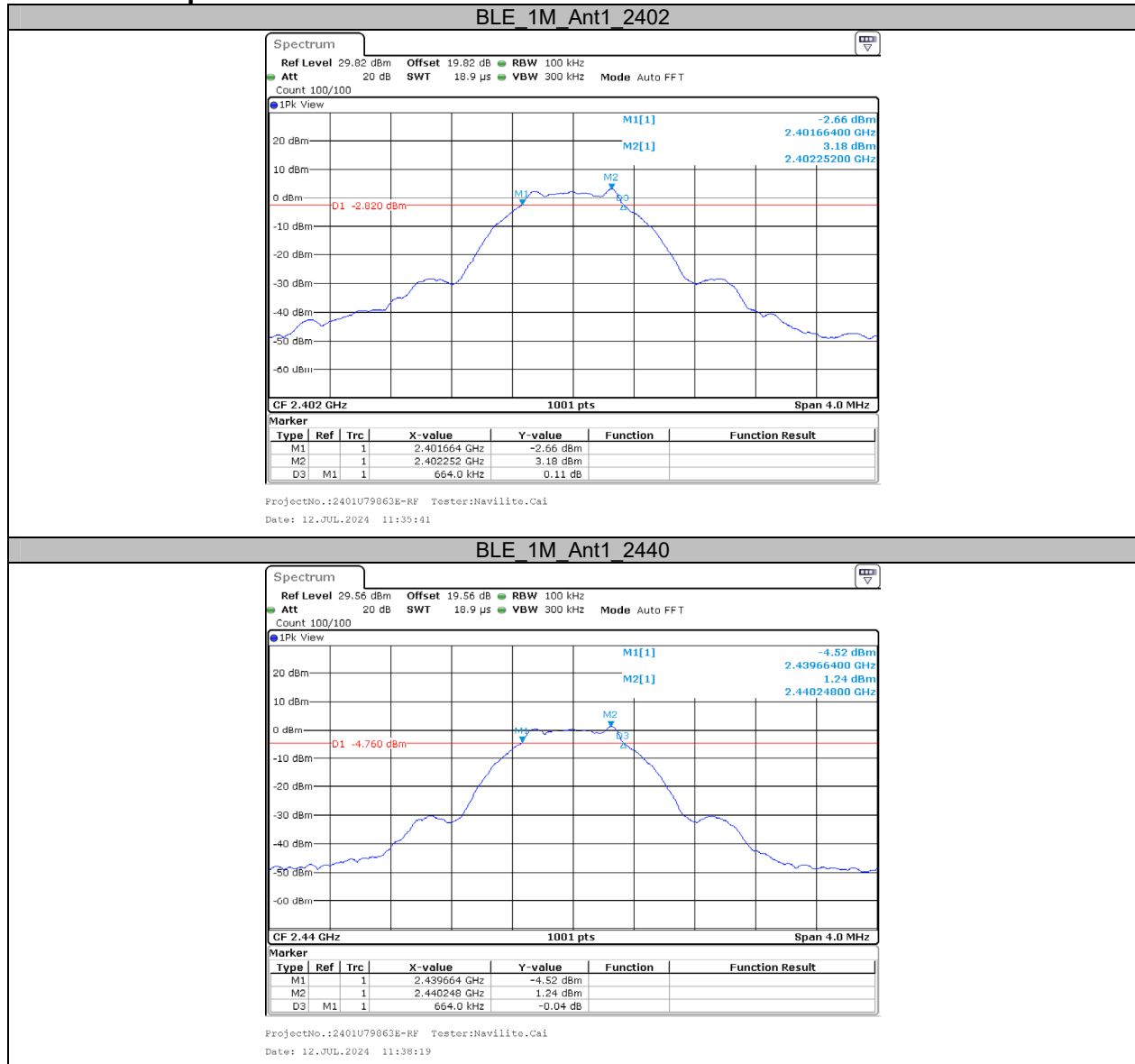

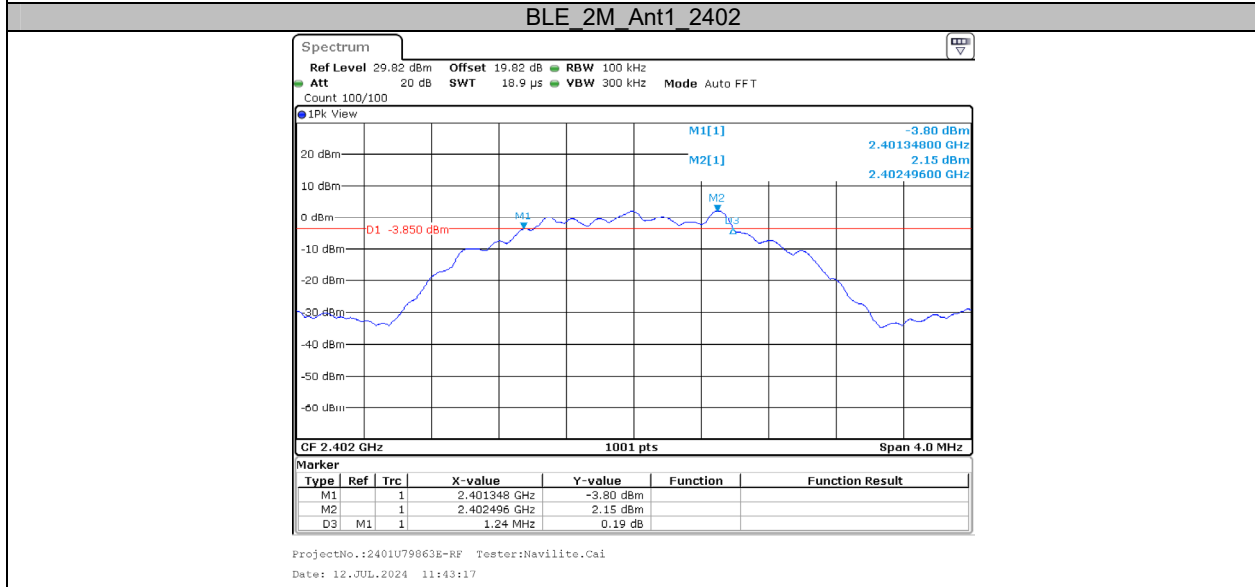
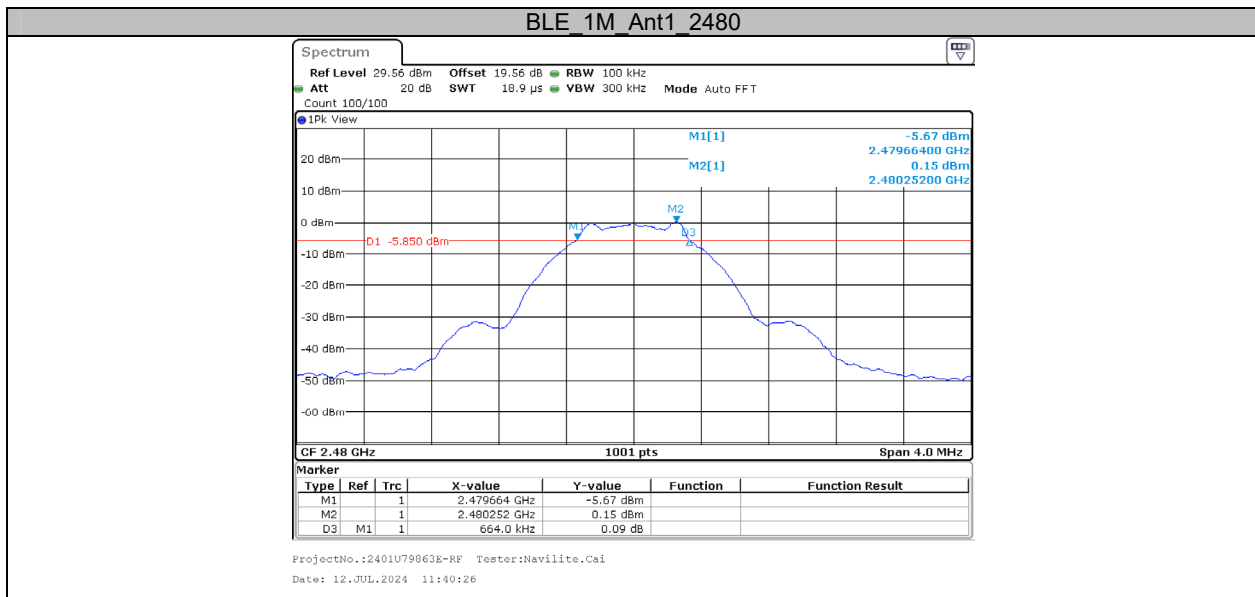

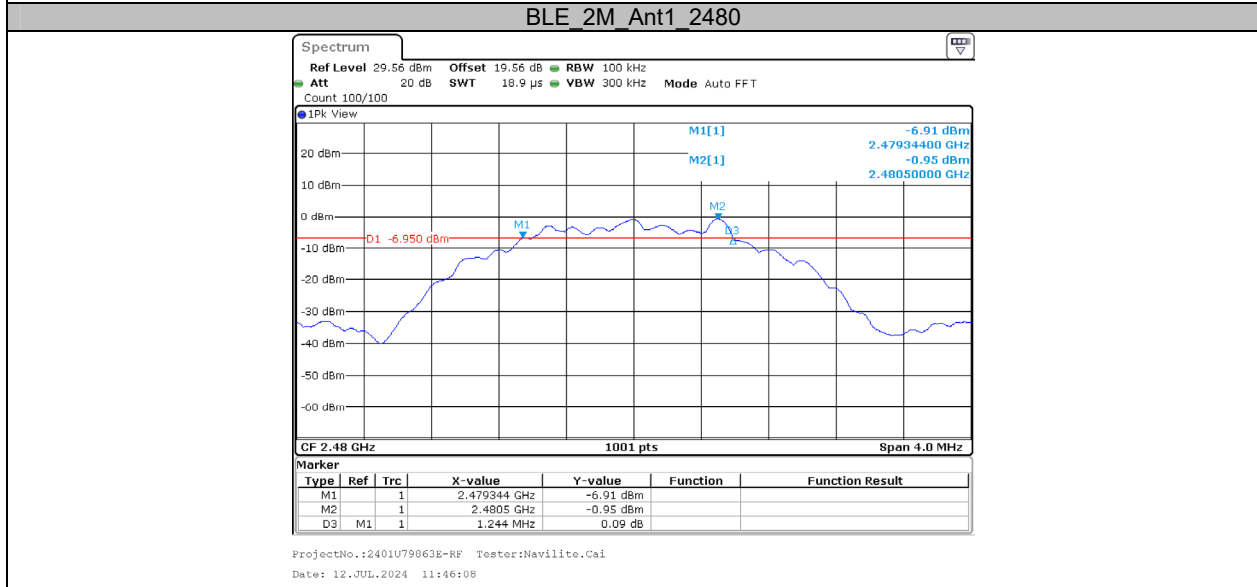
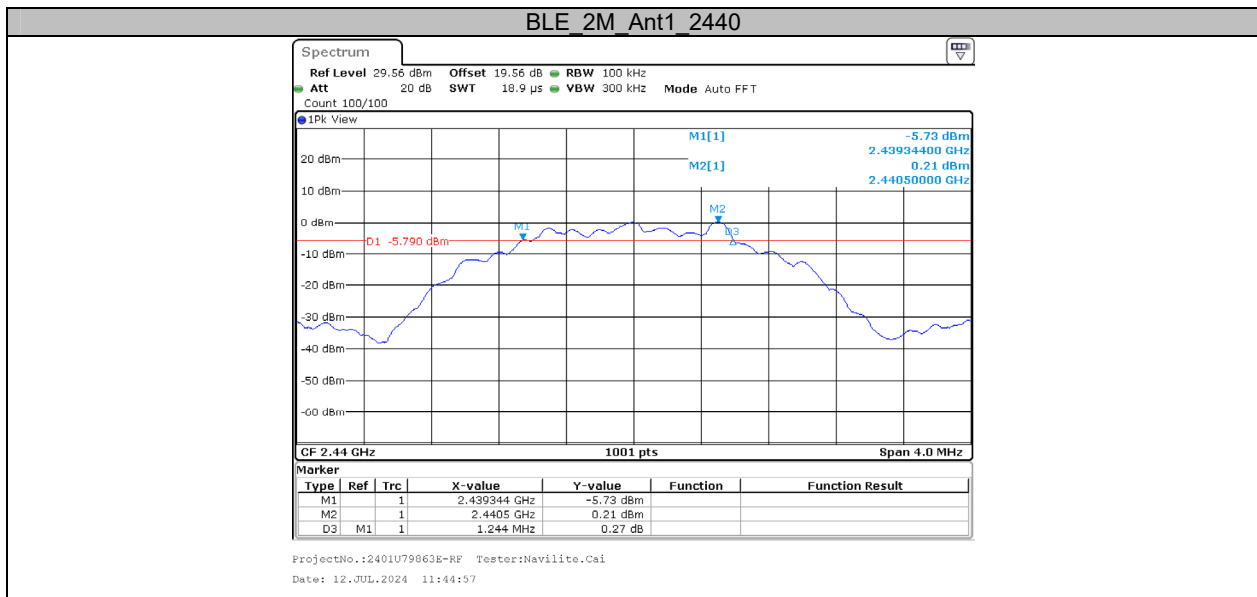

Appendix B: Occupied Channel Bandwidth**Test Result**

Test Mode	Antenna	Frequency[MHz]	OCB [MHz]	FL[MHz]	FH[MHz]	Limit[MHz]	Verdict
BLE_1M	Ant1	2402	1.023	2401.4925	2402.5155	---	---
		2440	1.019	2439.4925	2440.5115	---	---
		2480	1.019	2479.4925	2480.5115	---	---
BLE_2M	Ant1	2402	2.038	2400.9930	2403.0310	---	---
		2440	2.038	2438.9930	2441.0310	---	---
		2480	2.038	2478.9930	2481.0310	---	---

Test Graphs

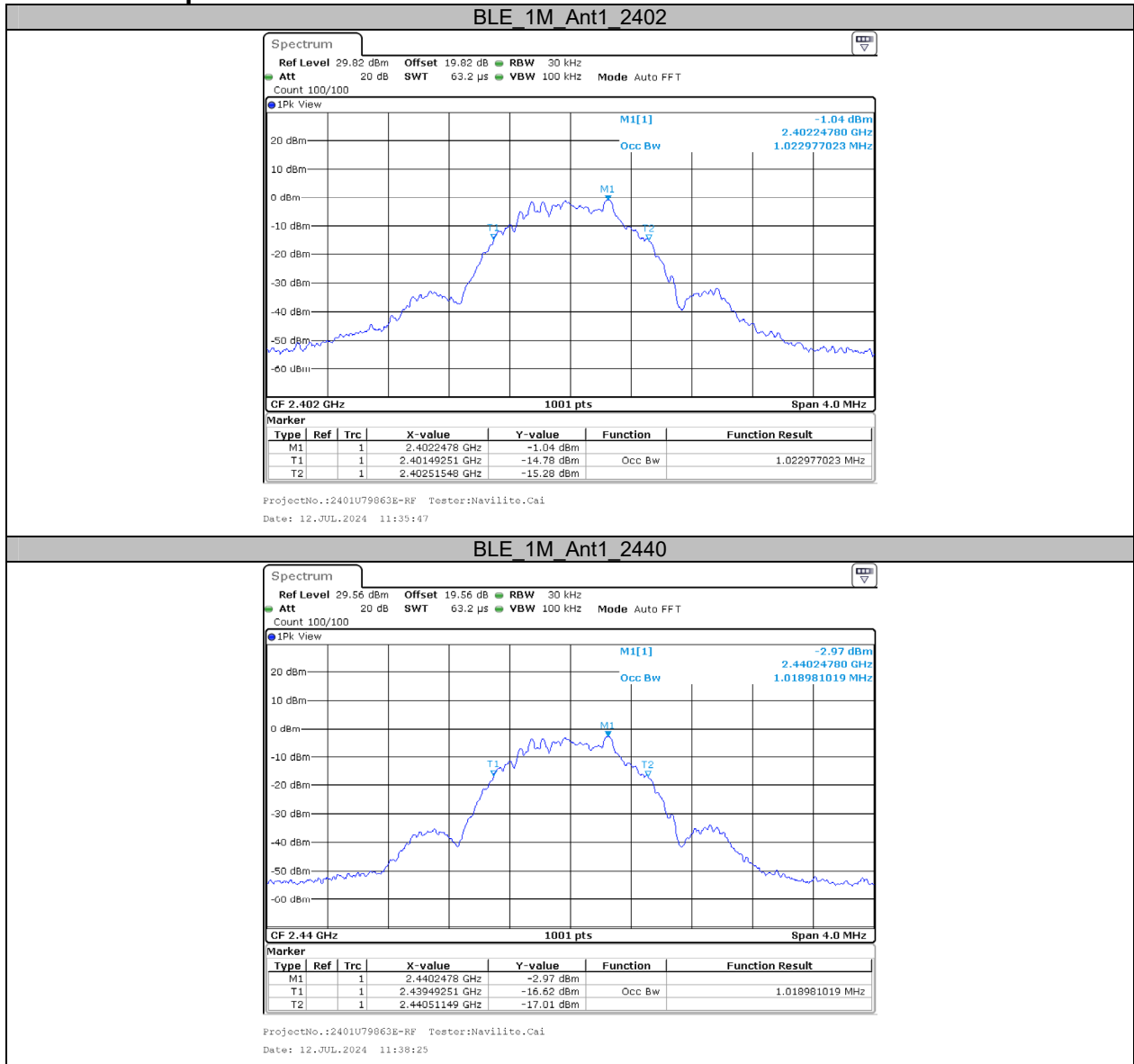

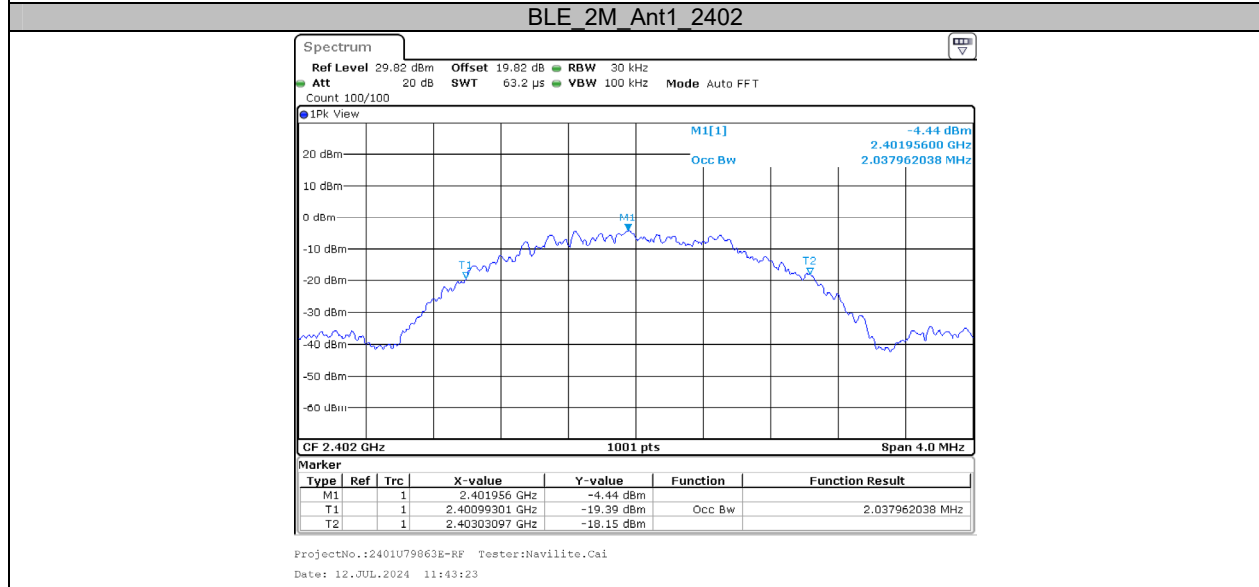
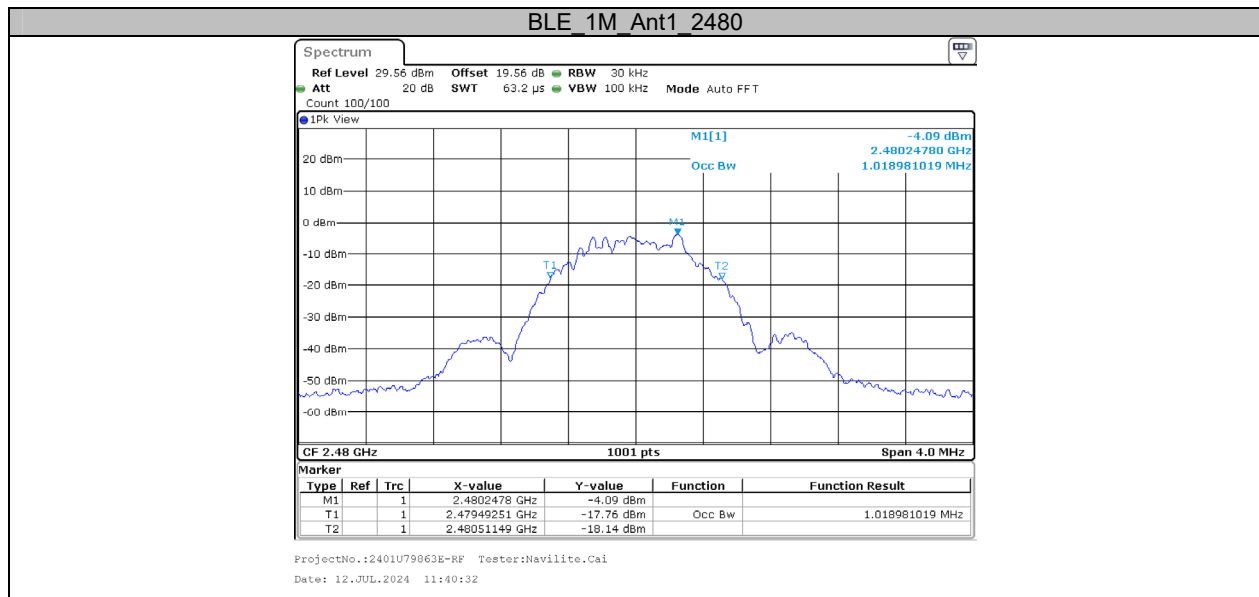

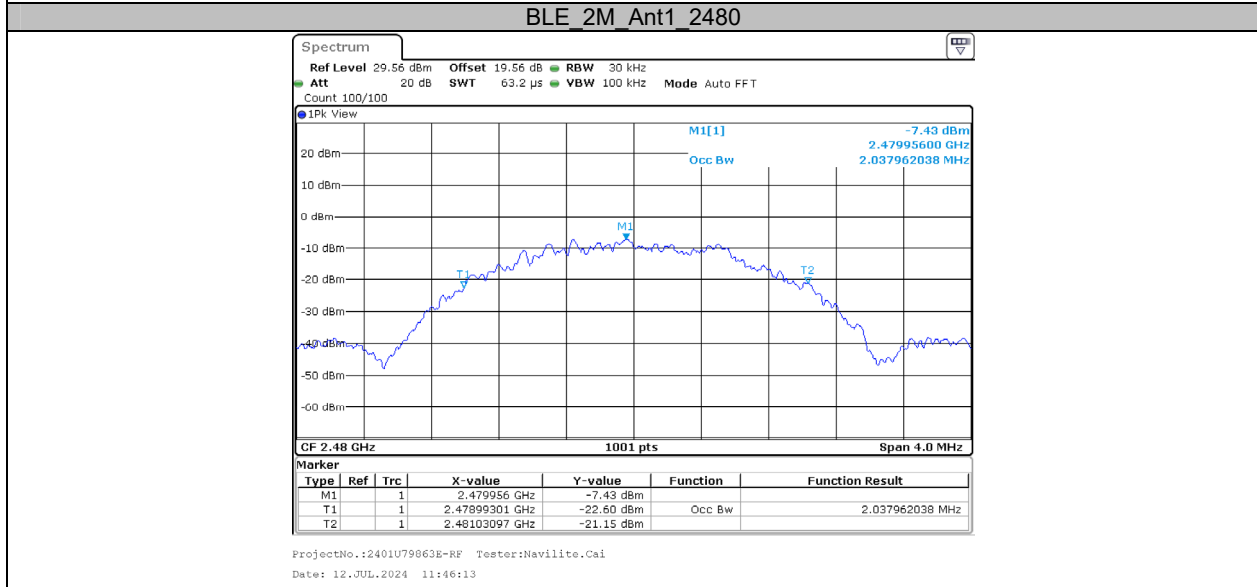
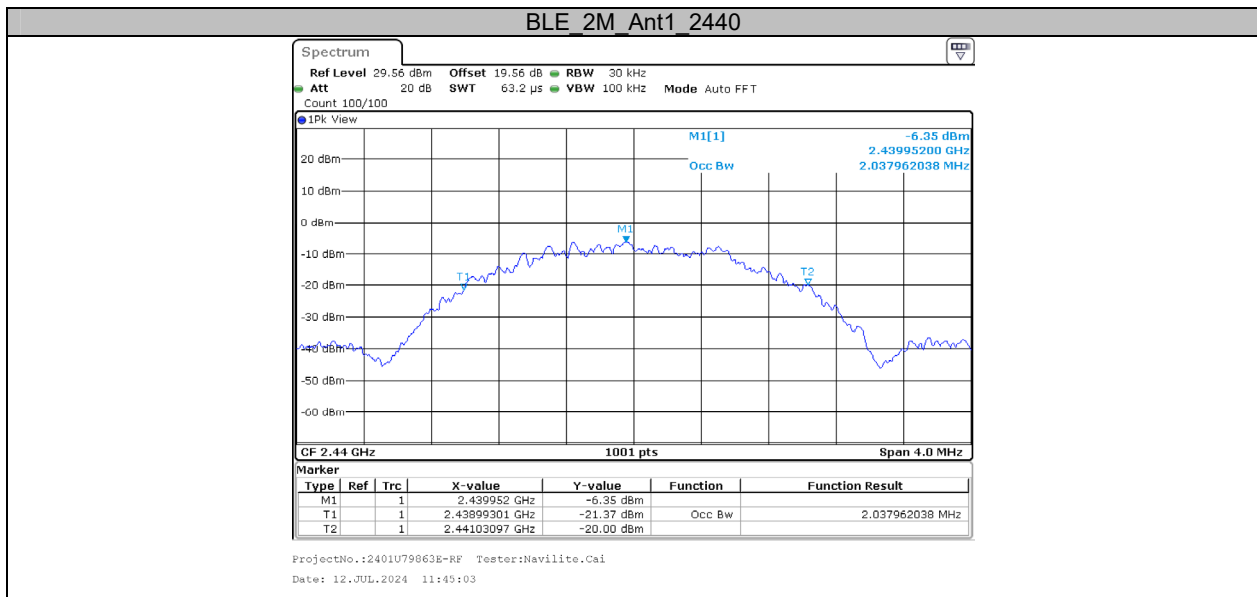

Appendix C: Maximum Conducted Output Power

Test Result Peak

Test Mode	Antenna	Frequency[MHz]	Conducted Peak Power[dBm]	Conducted Limit[dBm]	EIRP[dBm]	EIRP Limit[dBm]	Verdict
BLE_1M	Ant1	2402	3.43	≤30	8.53	≤36.00	PASS
		2440	1.57	≤30	6.67	≤36.00	PASS
		2480	0.48	≤30	5.58	≤36.00	PASS
BLE_2M	Ant1	2402	3.32	≤30	8.42	≤36.00	PASS
		2440	1.48	≤30	6.58	≤36.00	PASS
		2480	0.38	≤30	5.48	≤36.00	PASS

Test Graphs Peak

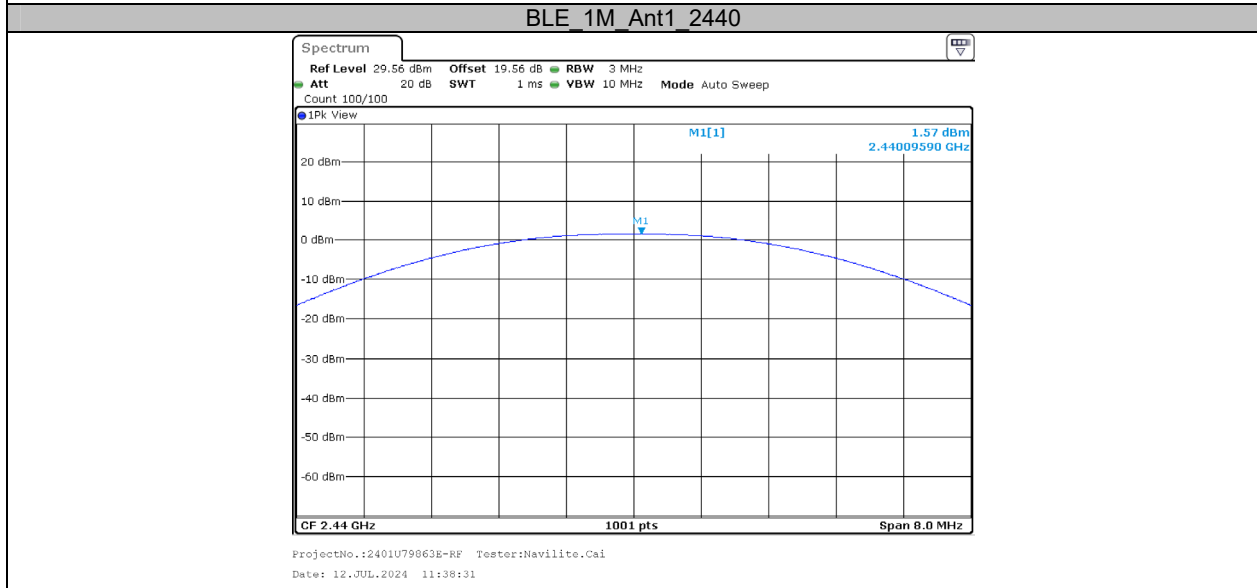
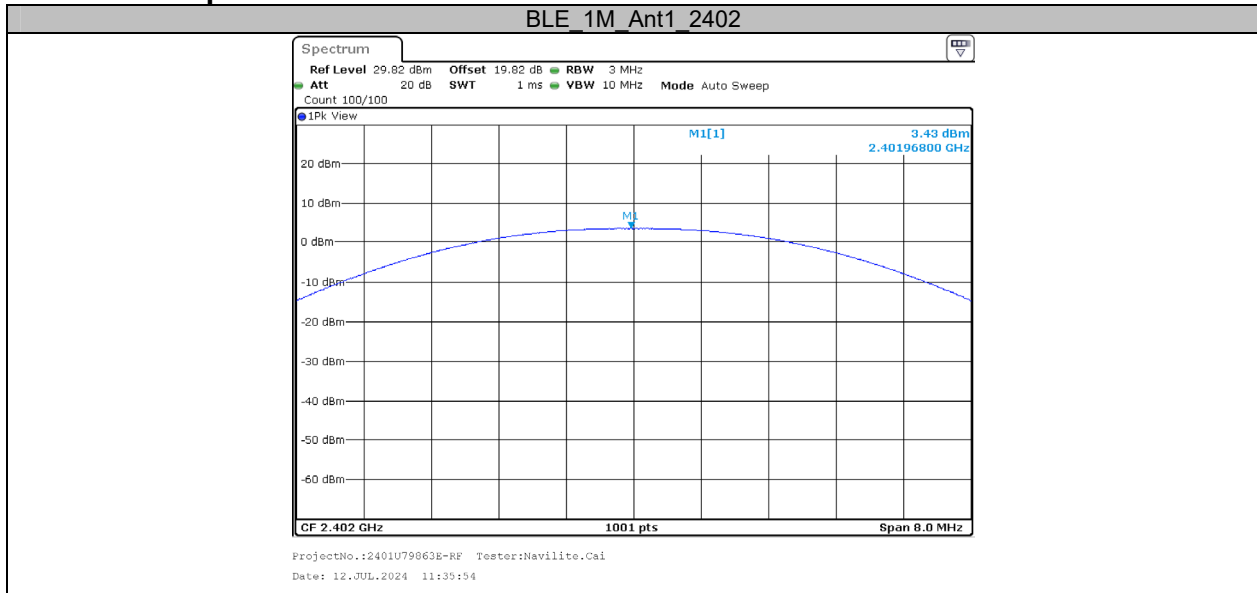

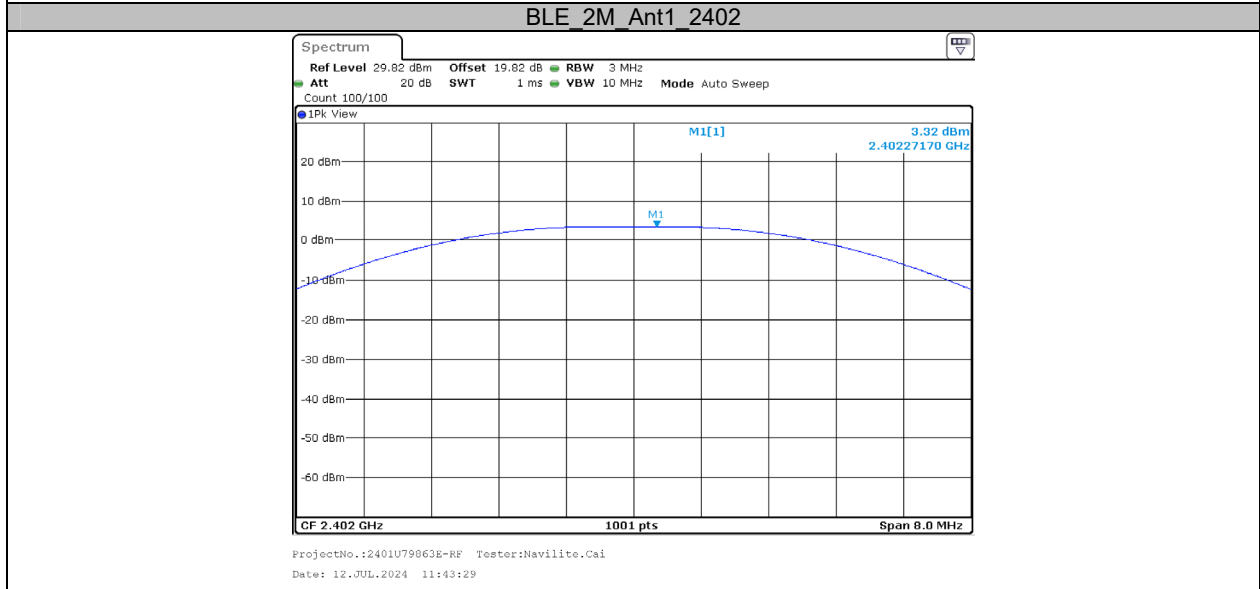
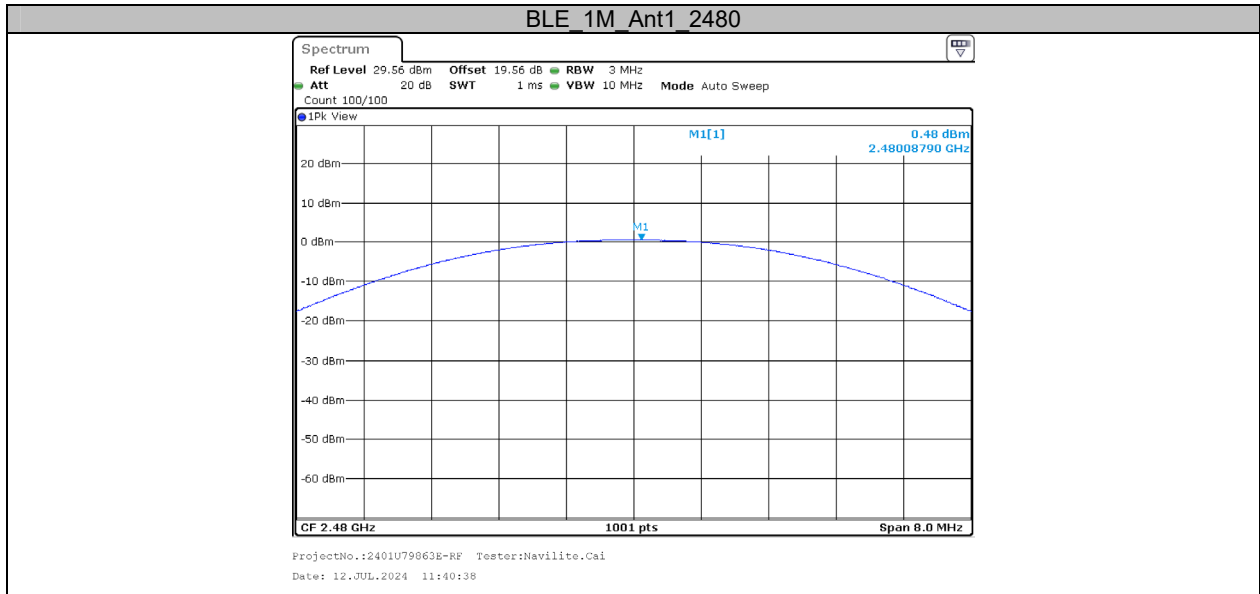

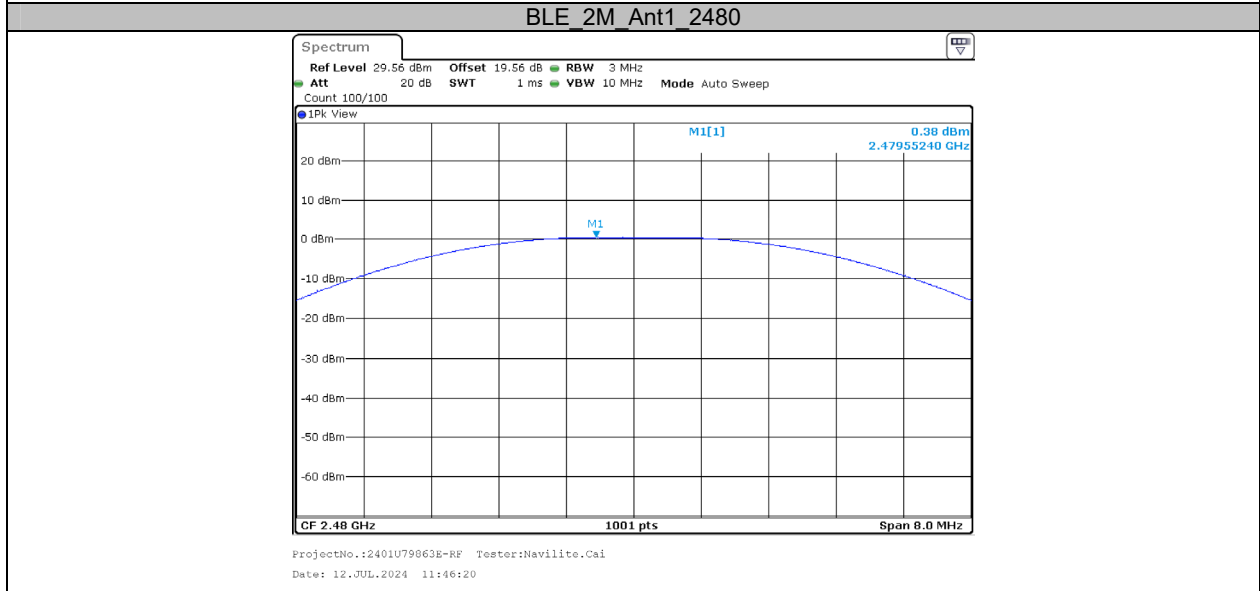
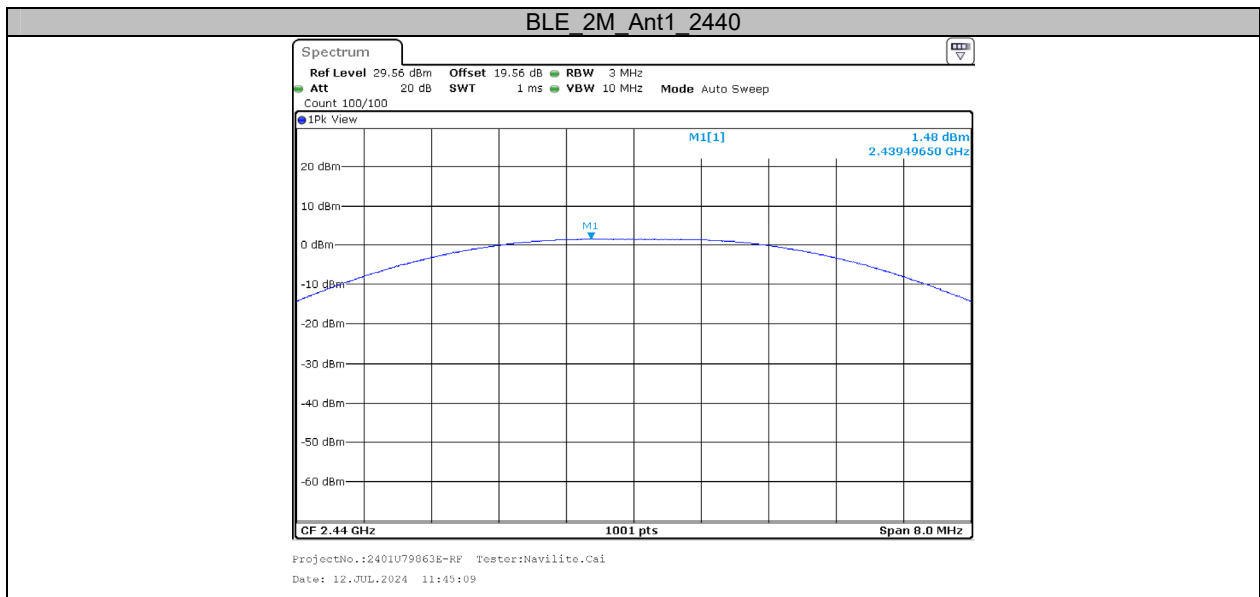

Appendix D: Maximum Power Spectral Density**Test Result**

Test Mode	Antenna	Frequency[MHz]	Result[dBm/3kHz]	Limit[dBm/3kHz]	Verdict
BLE_1M	Ant1	2402	-13.36	≤8.00	PASS
		2440	-15.25	≤8.00	PASS
		2480	-16.38	≤8.00	PASS
BLE_2M	Ant1	2402	-16.29	≤8.00	PASS
		2440	-18.14	≤8.00	PASS
		2480	-19.22	≤8.00	PASS

Test Graphs

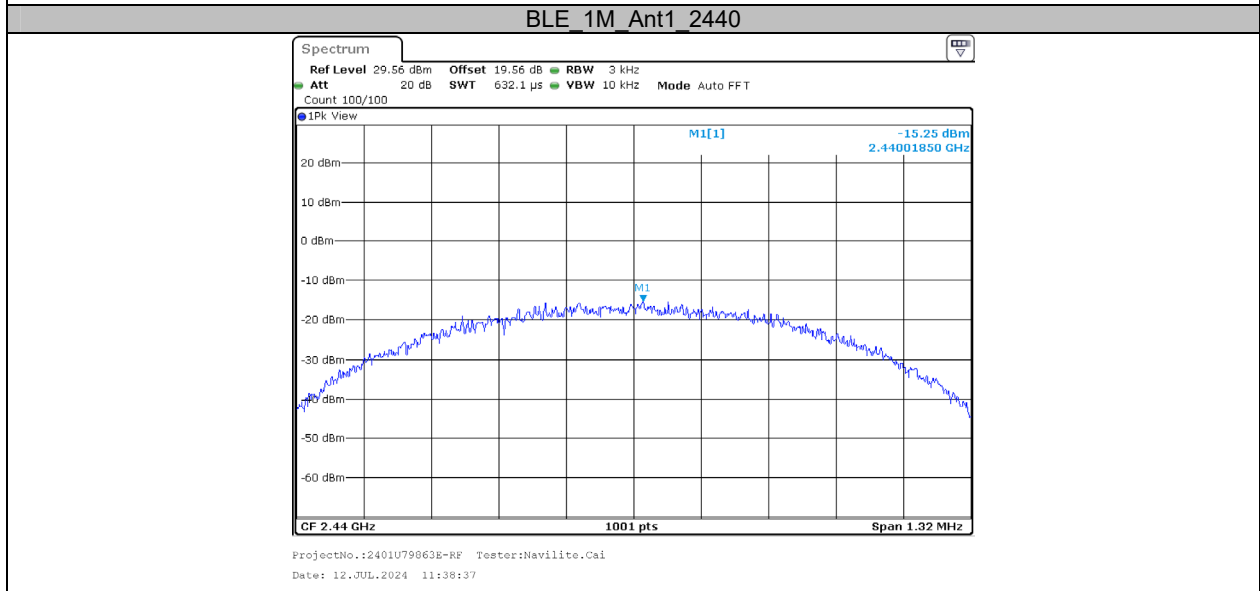
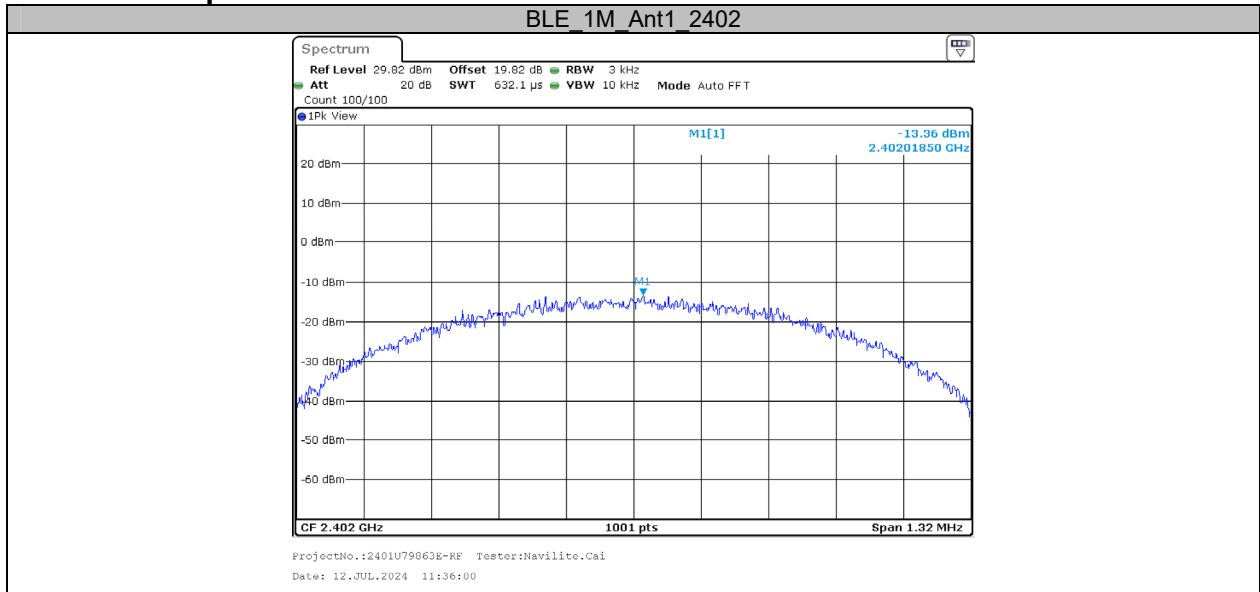

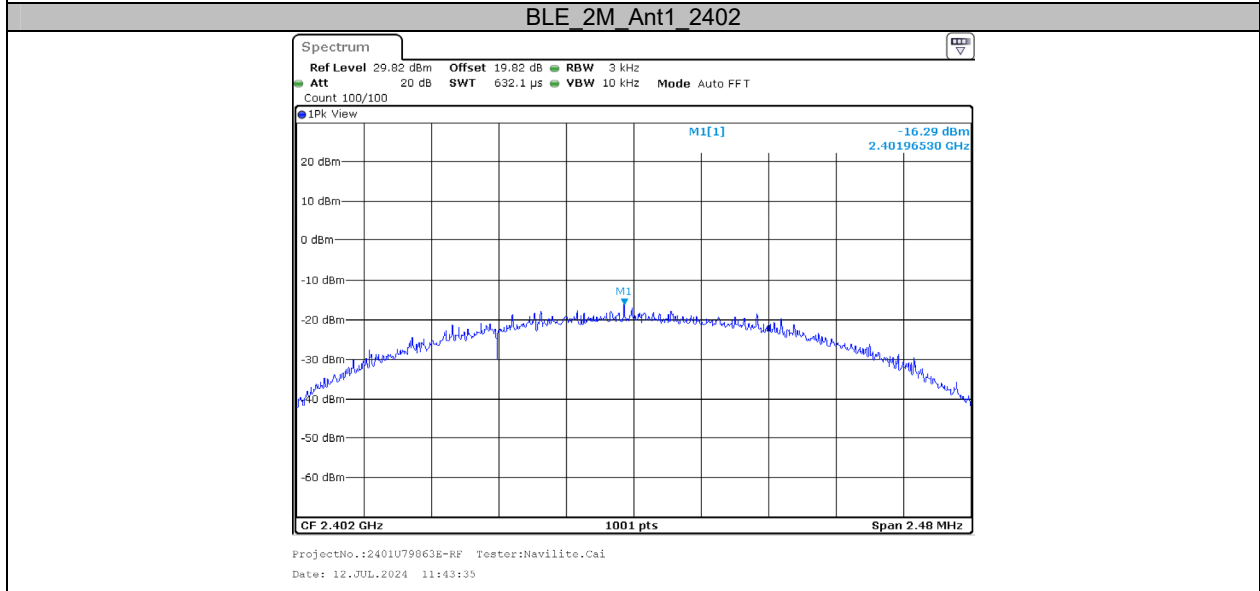
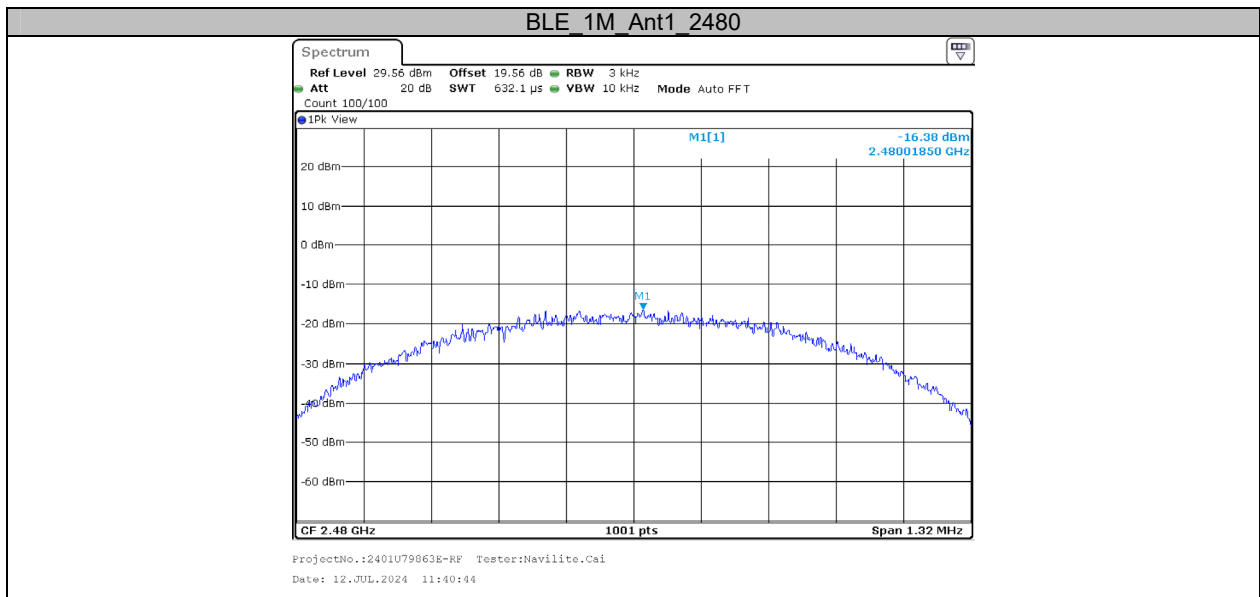

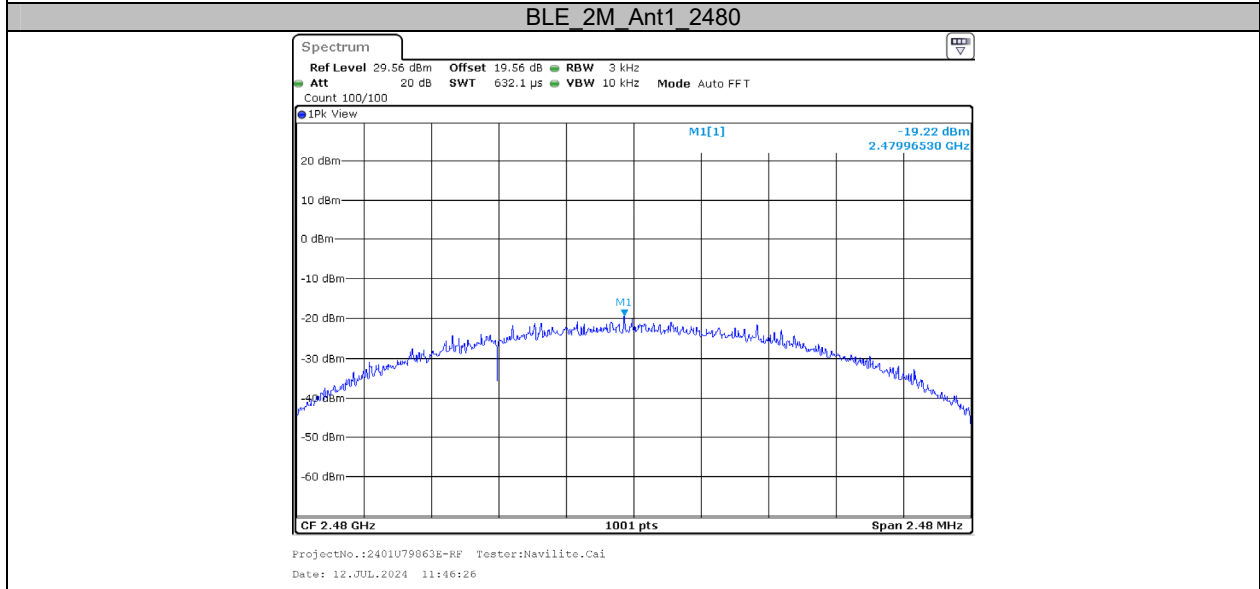
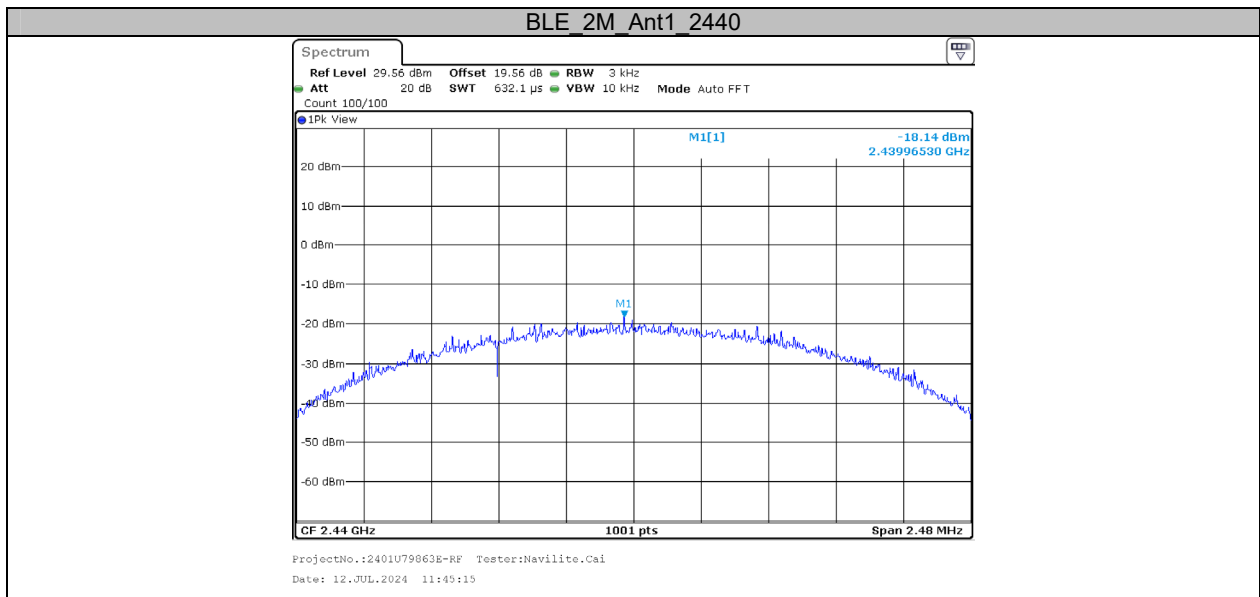

Appendix E: Band Edge Measurements

Test Graphs

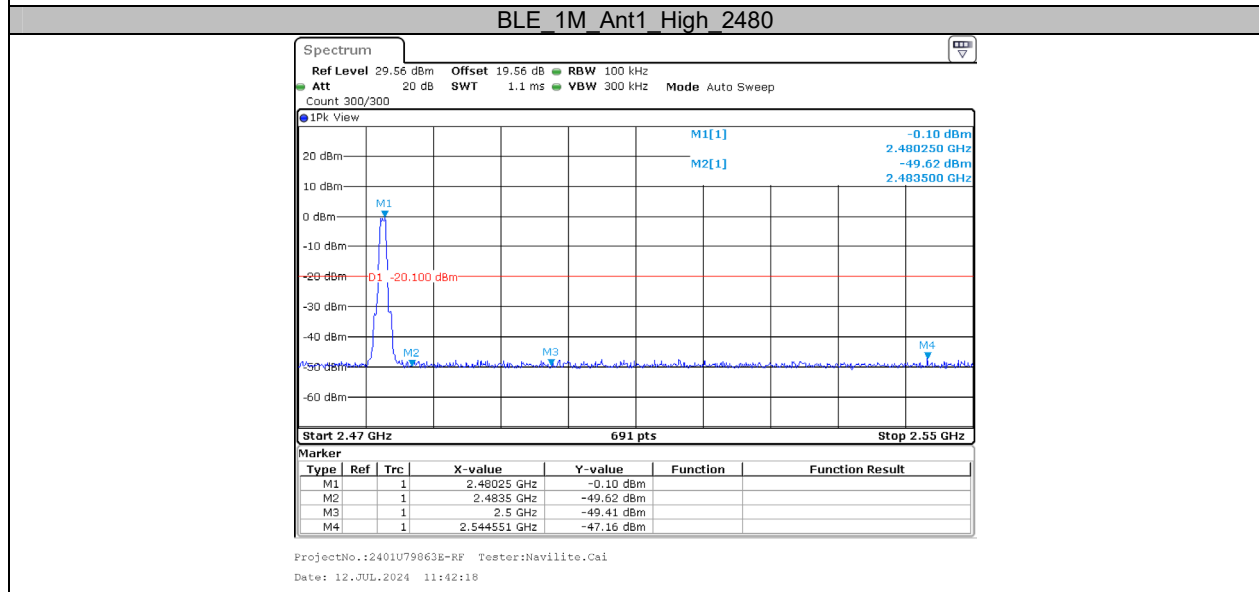
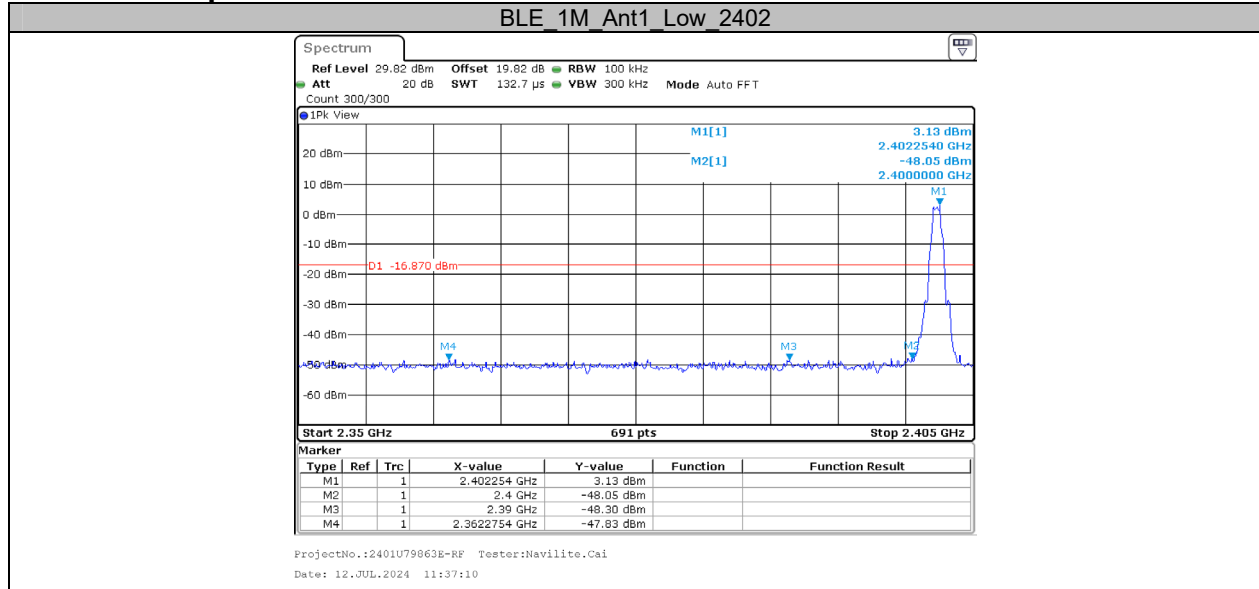

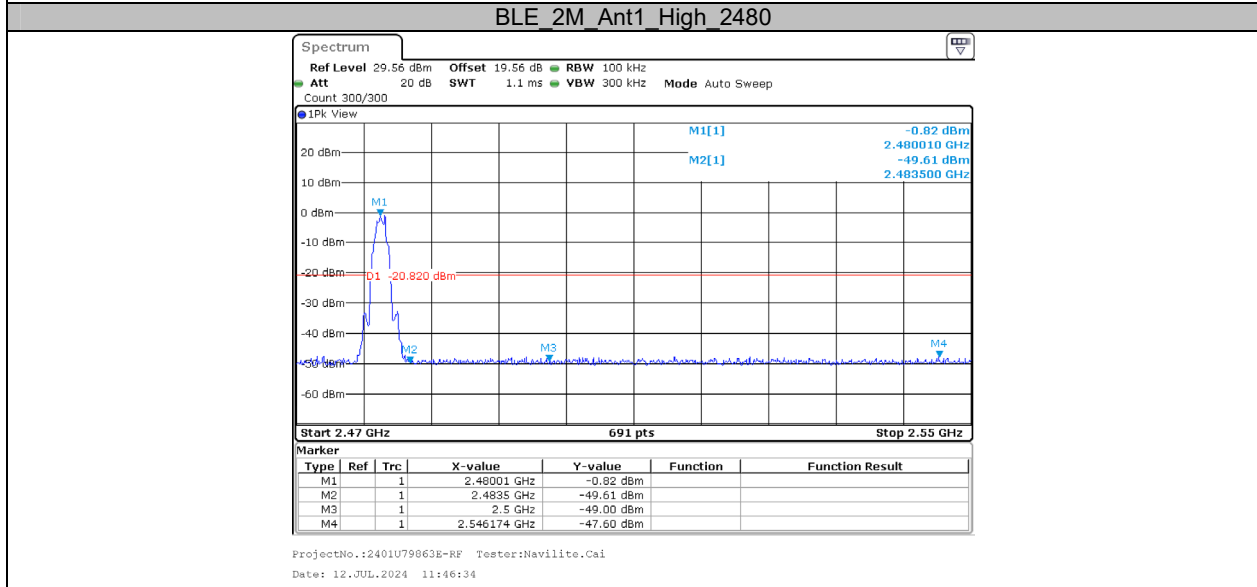
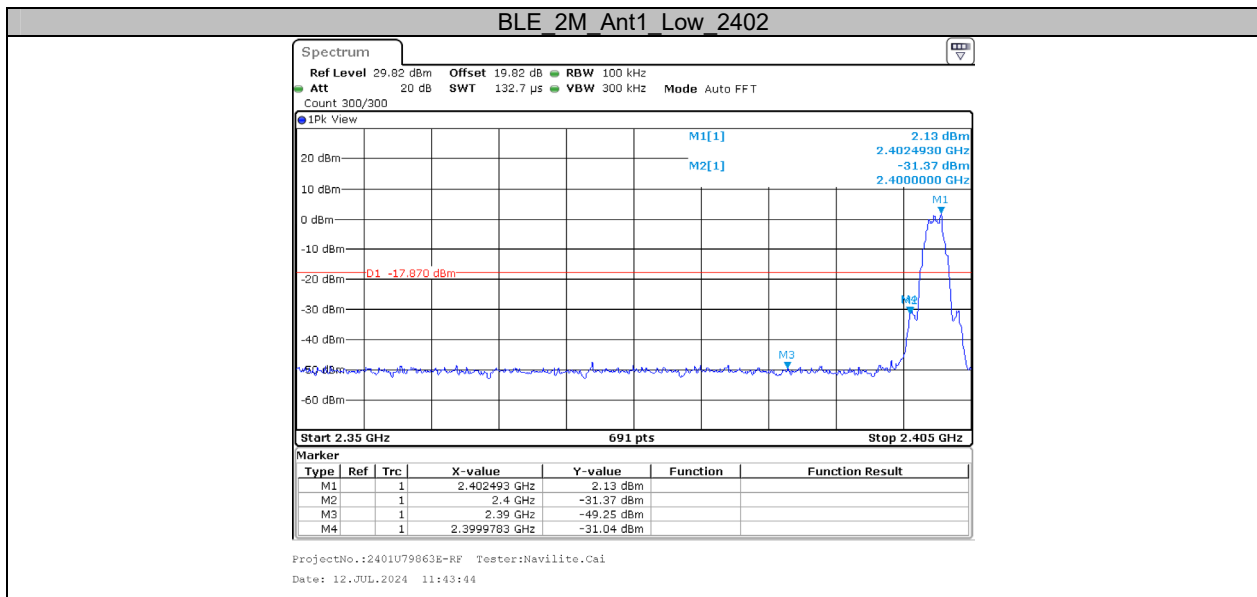

Appendix F: Duty Cycle**Test Result**

Test Mode	Antenna	Frequency [MHz]	ON Time [ms]	Period [ms]	Duty Cycle [%]	Duty Cycle Factor [dB]	1/T (Hz)	VBW setting (Hz)
BLE_1M	Ant1	2440	2.12	2.50	84.80	0.72	472	500
BLE_2M	Ant1	2440	1.06	1.87	56.68	2.47	943	1000

Test Graphs

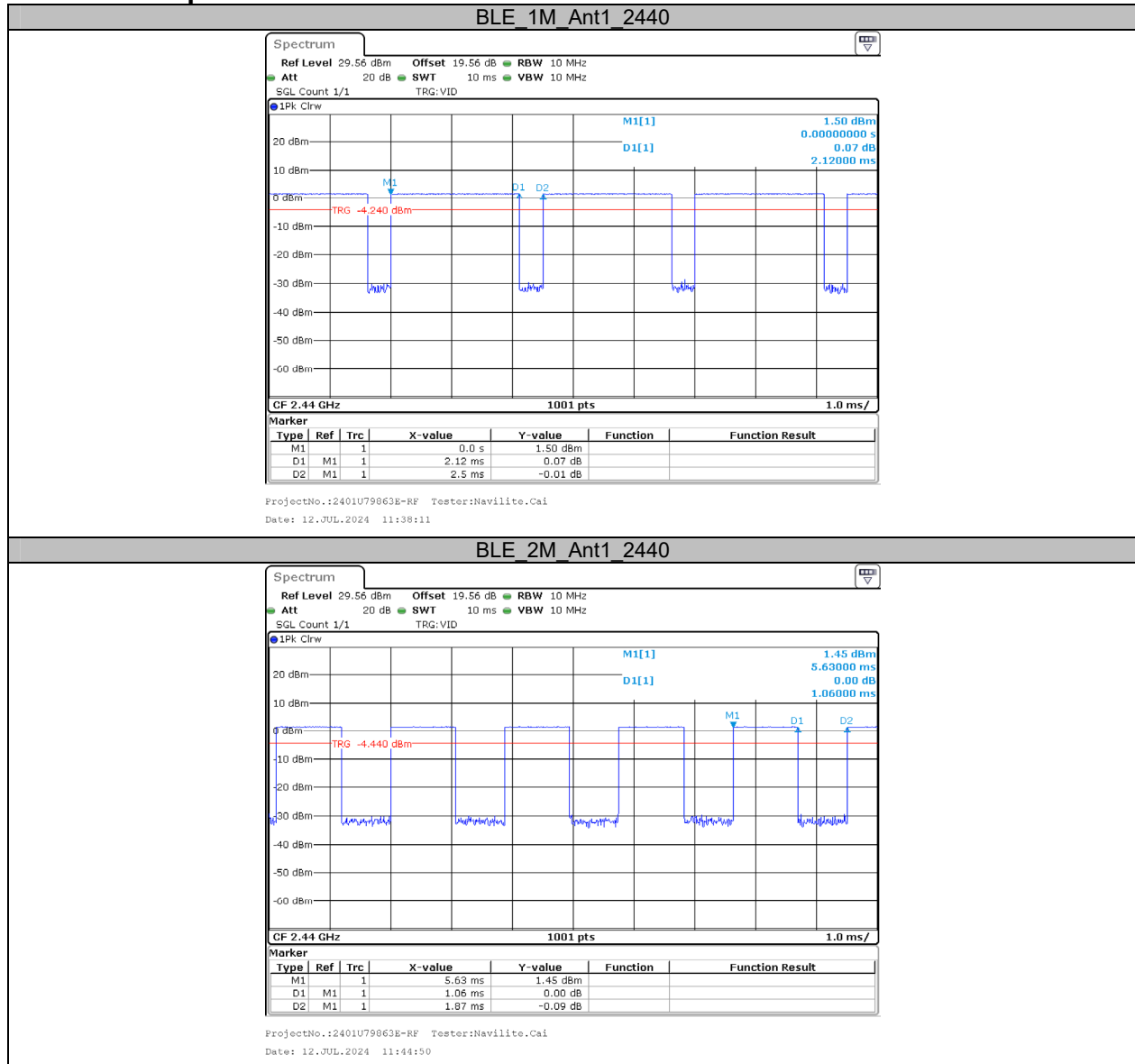

***** END OF REPORT *****