



Shenzhen CTL Testing Technology Co., Ltd.
Tel: +86-755-89486194 E-mail: ctl@ctl-lab.com

TEST REPORT

FCC Part 90S

Report Reference No. : CTL2405163031-W05

Compiled by: Happy Guo
(position+printed name+signature) (File administrators)

Tested by: Wuqiang Wu
(position+printed name+signature) (Test Engineer)

Approved by: Ivan Xie
(position+printed name+signature) (Manager)



Product Name : Portable RTK Receiver

Model/Type reference : P8 Global

List Model(s)..... : N/A

Trade Mark..... : TOKNAV

FCC ID..... : 2BCUE-P8GLOBAL

Applicant's name : Guangzhou Toksurvey Information Technology Co., Ltd

Address of applicant : No. 9, Caipin Road, Building B, Room 902-3,Huangpu District,Guangzhou, Guangdong,China

Test Firm..... : Shenzhen CTL Testing Technology Co., Ltd.

Address of Test Firm : Floor 1-A, Baisha Technology Park, No.3011, Shaheqi Road, Nanshan District, Shenzhen, China 518055

Test specification..... :

Standard : FCC CFR Title 47 Part 2, Part 90S
ANSI/TIA/EIA-603-E:2016
KDB 971168 D01

TRF Originator : Shenzhen CTL Testing Technology Co., Ltd.

Master TRF..... : Dated 2011-01

Date of receipt of test item : May 21, 2024

Date of sampling..... : May 21, 2024

Date of Test Date..... : May 21, 2024–Jun 28, 2024

Data of Issue..... : Jul 08, 2024

Result..... : Pass

Shenzhen CTL Testing Technology Co., Ltd. All rights reserved.

This publication may be reproduced in whole or in part for non-commercial purposes as long as the Shenzhen CTL Testing Technology Co., Ltd. is acknowledged as copyright owner and source of the material. Shenzhen CTL Testing Technology Co., Ltd. takes no responsibility for and will not assume liability for damages resulting from the reader's interpretation of the reproduced material due to its placement and context.

TEST REPORT

Test Report No. : CTL2405163031-W05	Jul 08, 2024
	Date of issue

Equipment under Test : Portable RTK Receiver

Sample No : CTL2405163031

Model /Type : P8 Glabal

Listed Models : N/A

Applicant : **Guangzhou Toksurvey Information Technology Co., Ltd**

Address : No. 9, Caipin Road, Building B, Room 902-3, Huangpu District, Guangzhou, Guangdong, China

Manufacturer : **Guangzhou Toksurvey Information Technology Co., Ltd**

Address : No. 9, Caipin Road, Building B, Room 902-3, Huangpu District, Guangzhou, Guangdong, China

Test result	Pass *
--------------------	---------------

*In the configuration tested, the EUT complied with the standards specified page 5.

The test results presented in this report relate only to the object tested.

This report shall not be reproduced, except in full, without the written approval of the issuing testing laboratory.

Table of Contents

Page

1. SUMMARY	5
1.1. TEST STANDARDS	5
1.2. TEST FACILITY	6
1.3. STATEMENT OF THE MEASUREMENT UNCERTAINTY	6
2. GENERAL INFORMATION	8
2.1. ENVIRONMENTAL CONDITIONS	8
2.2. GENERAL DESCRIPTION OF EUT	8
2.3. EQUIPMENTS USED DURING THE TEST	9
2.4. RELATED SUBMITTAL(S) / GRANT (S)	9
2.5. MODIFICATIONS	9
3. TEST CONDITIONS AND RESULTS	10
3.1. OUTPUT POWER	10
3.2. PEAK-TO-AVERAGE RATIO (PAR)	15
3.3. OCCUPIED BANDWIDTH AND EMISSION BANDWIDTH	16
3.4. BAND EDGE COMPLIANCE	17
3.5. SPURIOUS EMISSION	19
3.6. FREQUENCY STABILITY UNDER TEMPERATURE & VOLTAGE VARIATIONS	24
3.7. MODULATION CHARACTERISTICS	26
4. TEST SETUP PHOTOS OF THE EUT	27
5. EXTERNAL AND INTERNAL PHOTOS OF THE EUT	28

1. SUMMARY

1.1. TEST STANDARDS

The tests were performed according to following standards:

[FCC Part 90: PRIVATE LAND MOBILE RADIO SERVICES](#)

[ANSI/TIA/EIA-603-E March 2016: Land Mobile FM or PM Communications Equipment Measurement and Performance Standards.](#)

[FCC Part 2: FREQUENCY ALLOCATIONS AND RADIO TREATY MATTERS; GENERAL RULES AND REGULATIONS](#)

[KDB971168 D01:v03r01 MEASUREMENT GUIDANCE FOR CERTIFICATION OF LICENSED DIGITAL TRANSMITTERS](#)

[ANSI C63.10-2020 Methods of Measurement of Radio-Noise Emissions from Low-Voltage Electrical and Electronic Equipment in the Range of 9 kHz to 40 GHz](#)

Test Description

Test Item	Section in CFR 47	Result
Effective (Isotropic) Radiated Power Output Data	§ 90.635	Pass
Modulation Characteristics	§2.1047	Pass
Peak-to-Average Ratio (PAR)	§ 2.1046 §27.50(c)	Pass
Occupied Bandwidth	§ 2.1049 § 90.209	Pass
Band Edge compliance	§2.1051 § 90.543 (e)	Pass
Emission Mask	§90.210(n)	Pass
Spurious Emission	§2.1051 §2.1053 §90.543(c)(f)	Pass
Frequency Stability	§2.1055 Part 90.213	Pass

1.2. Test Facility

1.3.1 Address of the test laboratory

Shenzhen CTL Testing Technology Co., Ltd.

Floor 1-A, Baisha Technology Park, No.3011, Shahehexi Road, Nanshan District, Shenzhen, China 518055

There is one 3m semi-anechoic chamber and two line conducted labs for final test. The Test Sites meet the requirements in documents ANSI C63.4 and CISPR 32/EN 55032 requirements.

1.3.2 Laboratory accreditation

The test facility is recognized, certified, or accredited by the following organizations:

CNAS-Lab Code: L7497

Shenzhen CTL Testing Technology Co., Ltd. has been assessed and proved to be in compliance with CNAS-CL01 Accreditation Criteria for Testing and Calibration Laboratories (identical to ISO/IEC 17025: 2005 General Requirements) for the Competence of Testing and Calibration Laboratories.

A2LA-Lab Cert. No. 4343.01

Shenzhen CTL Testing Technology Co., Ltd, EMC Laboratory has been accredited by A2LA for technical competence in the field of electrical testing, and proved to be in compliance with ISO/IEC 17025: 2005 General Requirements for the Competence of Testing and Calibration Laboratories and any additional program requirements in the identified field of testing.

IC Registration No.: 9618B

CAB identifier: CN0041

The 3m alternate test site of Shenzhen CTL Testing Technology Co., Ltd. EMC Laboratory has been registered by Innovation, Science and Economic Development Canada to test to Canadian radio equipment requirements with Registration No.: 9618B.

FCC-Registration No.: 399832

Designation No.: CN1216

Shenzhen CTL Testing Technology Co., Ltd. EMC Laboratory has been registered and fully described in a report filed with the (FCC) Federal Communications Commission. The acceptance letter from the FCC is maintained in our files. Registration 399832.

1.3. Statement of the measurement uncertainty

The data and results referenced in this document are true and accurate. The reader is cautioned that there may be errors within the calibration limits of the equipment and facilities. The measurement uncertainty was calculated for all measurements listed in this test report acc. to CISPR 16 - 4 „Specification for radio disturbance and immunity measuring apparatus and methods – Part 4: Uncertainty in EMC Measurements“ and is documented in the Shenzhen CTL Testing Technology Co., Ltd. quality system acc. to DIN EN ISO/IEC 17025. Furthermore, component and process variability of devices similar to that tested may result in additional deviation. The manufacturer has the sole responsibility of continued compliance of the device.

Hereafter the best measurement capability for CTL laboratory is reported:

Test	Measurement Uncertainty	Notes
Transmitter power Radiated	±2.20 dB	(1)
Occupied Bandwidth	±0.02ppm	(1)
Radiated Emission 30~1000MHz	±4.10dB	(1)

Radiated Emission Above 1GHz	$\pm 4.32\text{dB}$	(1)
Conducted Disturbance 0.15~30MHz	$\pm 2.96\text{dB}$	(1)
20dB Emission Bandwidth	$\pm 1.9\%$	(1)
Carrier Frequency Separation	$\pm 1.9\%$	(1)
Maximum Power Spectral Density Level	$\pm 0.98\text{ dB}$	(1)
Number of Hopping Channel	$\pm 1.9\%$	(1)
Time of Occupancy	$\pm 0.11\%$	(1)
Max Peak Conducted Output Power	$\pm 0.98\text{ dB}$	(1)
Band-edge Spurious Emission	$\pm 1.21\text{dB}$	(1)
Conducted RF Spurious Emission	9kHz-7GHz: $\pm 1.09\text{dB}$ 7GHz-26.5GHz: $\pm 3.27\text{dB}$	(1)

1. This uncertainty represents an expanded uncertainty expressed at approximately the 95% confidence level using a coverage factor of $k=1.96$.

2. GENERAL INFORMATION

2.1. Environmental conditions

During the measurement the environmental conditions were within the listed ranges:

Normal Temperature:	25°C
Relative Humidity:	55 %
Air Pressure:	101 kPa

2.2. General Description of EUT

Product Name:	Portable RTK Receiver		
Model/Type reference:	P8 Global		
Power supply:	DC7.4V from battery & DC 5V from adapter		
Adapter information	Model : PS188120K1500UU InputL:100-240V~50/60Hz 0.5A Max Output:12V===1.5A,9V===2.0A, 5V===3A 18W Max		
LTE			
Mode:	LTE Band 26;		
Modulation Type:	QPSK 16QAM		
Operating Frequency Range(S)	Band	Tx(MHz)	Rx(MHz)
	LTE Band26	814~824	859~869
Release Version:	Release 9		
Category:	Cat 4		
Antenna type:	FPC Antenna		
Antenna gain:	Band 26: 0.94dBi		

Note: For more details, refer to the user's manual of the EUT.

Description of Test Modes

1. The EUT has been tested under typical operating condition. The CMW500 used to control the EUT staying in continuous transmitting and receiving mode for testing. Regards to the frequency band operation: the lowest, middle and highest frequency of channel were selected to perform the test, then shown on this report.

2. Test Frequencies

Test Mode	Bandwidth	RF Channel		
		Low (L)	Middle (M)	High (H)
LTE Band 26 (814~824)	1.4MHz	814.7 MHz	819MHz	823.3MHz
	3MHz	815.5 MHz	819MHz	822.5 MHz
	5MHz	816.5 MHz	819MHz	821.5 MHz
	10MHz	819 MHz		

2.3. Equipments Used during the Test

Test Equipment	Manufacturer	Model No.	Serial No.	Calibration Date	Calibration Due Date
Bilog Antenna	Sunol Sciences Corp.	JB1	A061713	2023/02/13	2026/02/12
Bilog Antenna	Sunol Sciences Corp.	JB1	A061714	2023/02/13	2026/02/12
EMI Test Receiver	R&S	ESCI	103710	2024/04/30	2025/04/29
Spectrum Analyzer	Agilent	N9020A	US46220290	2024/05/02	2025/05/01
Spectrum Analyzer	Keysight	N9020A	MY53420874	2024/05/02	2025/05/01
Horn Antenna	Sunol Sciences Corp.	DRH-118	A062013	2021/12/23	2024/12/22
Active Loop Antenna	BEIJING DA ZE TECHNOLOGY CO., LTD	ZN30900A	N/A	2024/04/30	2025/04/29
Amplifier	Agilent	8349B	3008A02306	2024/04/30	2025/04/29
Amplifier	Agilent	8447D	2944A10176	2024/04/30	2025/04/29
Temperature/Humidity Meter	Jiyu	MC501	02	2024/05/04	2025/05/03
Wideband Radio Communication Tester	R&S	CMW500	1201.0002K50-107930-CD	2024/5/1	2025/4/30
Climate Chamber	Jingbang	TLHW-64B	N/A	2024/05/04	2025/05/03
SIGNAL GENERATOR	Wiltron	68347B	657001	2024/05/01	2025/04/30
Power Sensor	Agilent	U2021XA	MY5365004	2024/05/04	2025/05/03
Power Meter	Agilent	E4419B	GB43317877	2023/08/02	2024/08/01

2.4. Related Submittal(s) / Grant (s)

This submittal(s) (test report) is intended to comply with of the Part 90 Rules.

2.5. Modifications

No modifications were implemented to meet testing criteria.

3. TEST CONDITIONS AND RESULTS

3.1. Output Power

LIMIT

According to §90.542(a) specifies “Control stations and mobile stations transmitting in the 758-768 MHz band and the 788-798 MHz band are limited to 3 watts ERP.”

TEST CONFIGURATION

Conducted Power Measurement

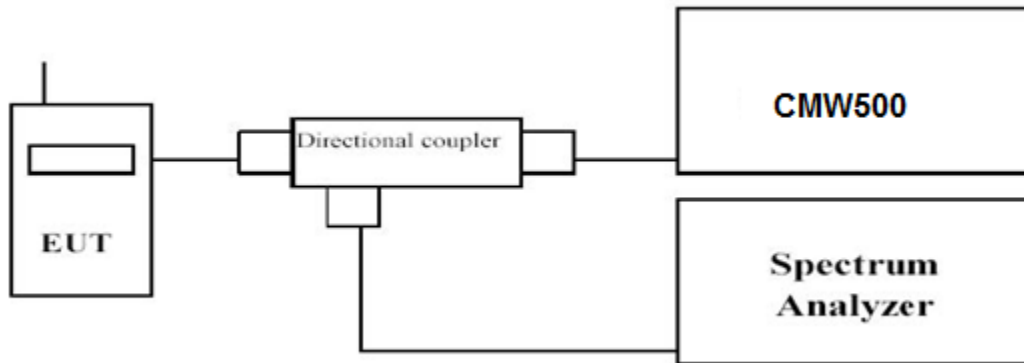

(A) Radiated Emission Test Set-Up, Frequency Below 30MHz

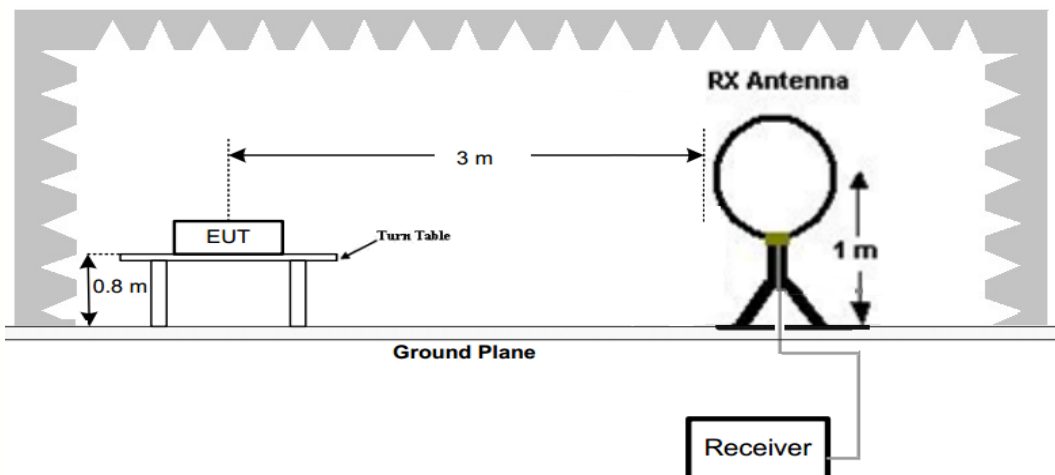

(B) Radiated Emission Test Set-Up, Frequency below 1000MHz

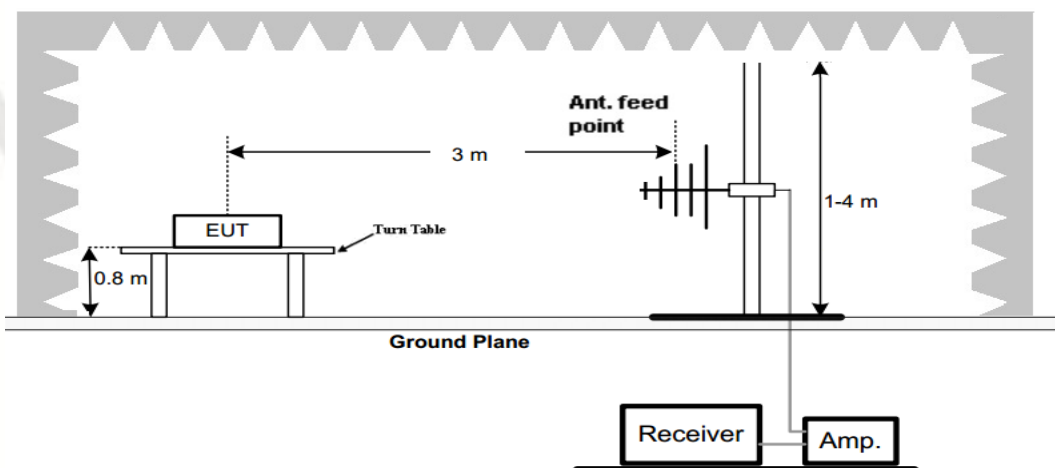

(C) Radiated Emission Test Set-Up, Frequency above 1000MHz

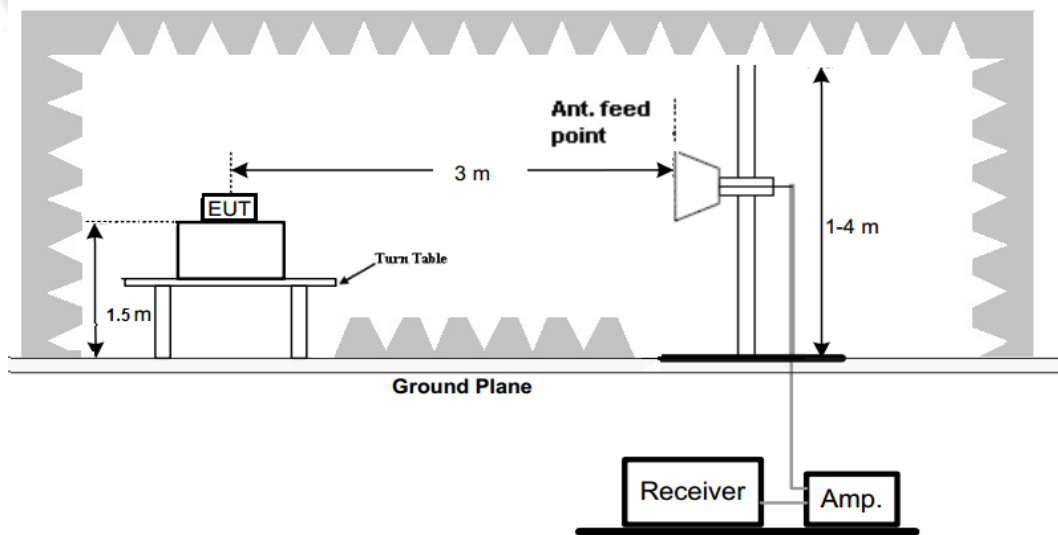

TEST PROCEDURE

The EUT was setup according to ANSI/TIA/EIA-603-E

Conducted Power Measurement:

- Place the EUT on a bench and set it in transmitting mode.
- Connect a low loss RF cable from the antenna port to a spectrum analyzer and CMW500 by a Directional Couple.
- EUT Communicate with CMW500 then selects a channel for testing.
- Add a correction factor to the display of spectrum, and then test.

Radiated Power Measurement:

- The EUT shall be placed at the specified height on a support, and in the position closest to normal use as declared by provider.
- The test antenna shall be oriented initially for vertical polarization and shall be chosen to correspond to the frequency of the transmitter
- The output of the test antenna shall be connected to the measuring receiver.
- The transmitter shall be switched on and the measuring receiver shall be tuned to the frequency of the transmitter under test.
- The test antenna shall be raised and lowered through the specified range of height until a maximum signal level is detected by the measuring receiver.
- The transmitter shall then be rotated through 360° in the horizontal plane, until the maximum signal level is detected by the measuring receiver.
- The test antenna shall be raised and lowered again through the specified range of height until a maximum signal level is detected by the measuring receiver.
- The maximum signal level detected by the measuring receiver shall be noted.
- The transmitter shall be replaced by a substitution antenna.
- The substitution antenna shall be orientated for vertical polarization and the length of the substitution antenna shall be adjusted to correspond to the frequency of the transmitter.
- The substitution antenna shall be connected to a calibrated signal generator.

- l) If necessary, the input attenuator setting of the measuring receiver shall be adjusted in order to increase the sensitivity of the measuring receiver.
- m) The test antenna shall be raised and lowered through the specified range of height to ensure that the maximum signal is received.
- n) The input signal to the substitution antenna shall be adjusted to the level that produces a level detected by the measuring receiver, that is equal to the level noted while the transmitter radiated power was measured, corrected for the change of input attenuator setting of the measuring receiver.
- o) The measurement shall be repeated with the test antenna and the substitution antenna orientated for horizontal polarization.
- p) The measure of the effective radiated power is the larger of the two levels recorded at the input to the substitution antenna, corrected for gain of the substitution antenna if necessary.
- q) Test site anechoic chamber refer to ANSI C63.4.

TEST RESULTS

Conducted Measurement:

1. please refer to Appendix for 4G_LTE_band_26_814-824MHz: Section 1

Radiated Measurement:

Remark:

1. We were tested all RB Configuration refer 3GPP TS136 521 for each Channel Bandwidth of LTE Band 2, LTE Band 26; recorded worst case for each Channel Bandwidth of LTE Band 2 and LTE Band 26
2. $EIRP = P_{Mea}(dBm) - P_{cl}(dB) + P_{Ag}(dB) + G_a(dBi)$
3. $ERP = EIRP - 2.15dBi$ as EIRP by subtracting the gain of the dipole.

LTE FDD Band 26(814~824)*LTE FDD Band 26_Channel Bandwidth 1.4MHz_QPSK*

Frequency (MHz)	P _{Mea} (dBm)	P _{cl} (dB)	G _a Antenna Gain(dB)	Correction (dB)	P _{Ag} (dB)	ERP (dBm)	Limit (dBm)	Margin (dB)
814.7	-19.65	3.58	9.62	33.79	20.18	18.03	50	-31.97
819	-18.34	3.61	9.22	34.64	21.91	19.76	50	-30.24
823.3	-19.44	3.64	9.04	34.75	20.71	18.56	50	-31.44

LTE FDD Band 26_Channel Bandwidth 3MHz_QPSK

Frequency (MHz)	P _{Mea} (dBm)	P _{cl} (dB)	G _a Antenna Gain(dB)	Correction (dB)	P _{Ag} (dB)	ERP (dBm)	Limit (dBm)	Margin (dB)
815.5	-19.45	3.58	9.62	33.79	20.38	18.23	50	-31.77
819	-18.13	3.61	9.22	34.64	22.12	19.97	50	-30.03
822.5	-19.70	3.64	9.04	34.75	20.45	18.30	50	-31.70

LTE FDD Band 26_Channel Bandwidth 5MHz_QPSK

Frequency (MHz)	P _{Mea} (dBm)	P _{cl} (dB)	G _a Antenna Gain(dB)	Correction (dB)	P _{Ag} (dB)	ERP (dBm)	Limit (dBm)	Margin (dB)
816.5	-19.81	3.58	9.62	33.79	20.02	17.87	50	-32.13
819	-18.24	3.61	9.22	34.64	22.01	19.86	50	-30.14
821.5	-19.64	3.64	9.04	34.75	20.51	18.36	50	-31.64

LTE FDD Band 26_Channel Bandwidth 10MHz_QPSK

Frequency (MHz)	P _{Mea} (dBm)	P _{cl} (dB)	G _a Antenna Gain(dB)	Correction (dB)	P _{Ag} (dB)	ERP (dBm)	Limit (dBm)	Margin (dB)
819	-19.58	3.64	9.04	34.75	20.57	18.42	50	-31.58

LTE FDD Band 26_Channel Bandwidth 1.4MHz_16QAM

Frequency (MHz)	P _{Mea} (dBm)	P _{cl} (dB)	G _a Antenna Gain(dB)	Correction (dB)	P _{Ag} (dB)	ERP (dBm)	Limit (dBm)	Margin (dB)
-19.82	-19.70	3.58	9.62	33.79	20.13	17.98	50	-32.02
-18.27	-18.29	3.61	9.22	34.64	21.96	19.81	50	-30.19
-19.55	-19.72	3.64	9.04	34.75	20.43	18.28	50	-31.72

LTE FDD Band 26_Channel Bandwidth 3MHz_16QAM

Frequency (MHz)	P _{Mea} (dBm)	P _{cl} (dB)	G _a Antenna Gain(dB)	Correction (dB)	P _{Ag} (dB)	ERP (dBm)	Limit (dBm)	Margin (dB)
815.5	-19.54	3.58	9.62	33.79	20.29	18.14	50	-31.86
819	-18.11	3.61	9.22	34.64	22.14	19.99	50	-30.01
822.5	-19.50	3.64	9.04	34.75	20.65	18.50	50	-31.50

LTE FDD Band 26_Channel Bandwidth 5MHz_16QAM

Frequency (MHz)	P _{Mea} (dBm)	P _{cl} (dB)	G _a Antenna Gain(dB)	Correction (dB)	P _{Ag} (dB)	ERP (dBm)	Limit (dBm)	Margin (dB)
816.5	-19.64	3.58	9.62	33.79	20.19	18.04	50	-31.96
819	-18.27	3.61	9.22	34.64	21.98	19.83	50	-30.17
821.5	-19.47	3.64	9.04	34.75	20.68	18.53	50	-31.47

LTE FDD Band 26_Channel Bandwidth 10MHz_16QAM

Frequency (MHz)	P _{Mea} (dBm)	P _{cl} (dB)	G _a Antenna Gain(dB)	Correction (dB)	P _{Ag} (dB)	ERP (dBm)	Limit (dBm)	Margin (dB)
819	-18.27	3.61	9.22	34.64	21.98	19.83	50	-30.17

3.2. Peak-to-Average Ratio (PAR)

LIMIT

The Peak-to-Average Ratio (PAR) of the transmission may not exceed 13 dB.in 24.232 (d)

TEST CONFIGURATION

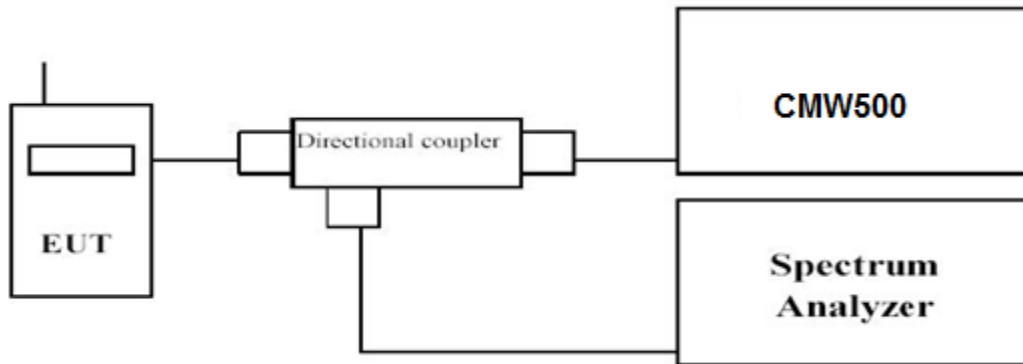

TEST PROCEDURE

1. Refer to instrument's analyzer instruction manual for details on how to use the power statistics/CCDF function;
2. Set resolution/measurement bandwidth \geq signal's occupied bandwidth;
3. Set the number of counts to a value that stabilizes the measured CCDF curve;
4. Set the measurement interval as follows:
 - 1). for continuous transmissions, set to 1 ms,
 - 2). for burst transmissions, employ an external trigger that is synchronized with the EUT burst timing sequence, or use the internal burst trigger with a trigger level that allows the burst to stabilize and set the measurement interval to a time that is less than or equal to the burst duration.
5. Record the maximum PAPR level associated with a probability of 0.1%.

TEST RESULTS

1. please refer to Appendix for 4G_LTE_band_26_814-824MHz: Section 5

3.3. Occupied Bandwidth and Emission Bandwidth

LIMIT

No specific occupied bandwidth requirements in part 2.1049.

Part 90.209 (a) Each authorization issued to a station licensed under this part will show an emission designator representing the class of emission authorized. The designator will be prefixed by a specified necessary bandwidth. This number does not necessarily indicate the bandwidth occupied by the emission at any instant. In those cases where part 2.202 of this chapter does not provide a formula for the computation of necessary bandwidth, the occupied bandwidth, as defined in part 2 of this chapter, may be used in lieu of the necessary bandwidth.

TEST CONFIGURATION

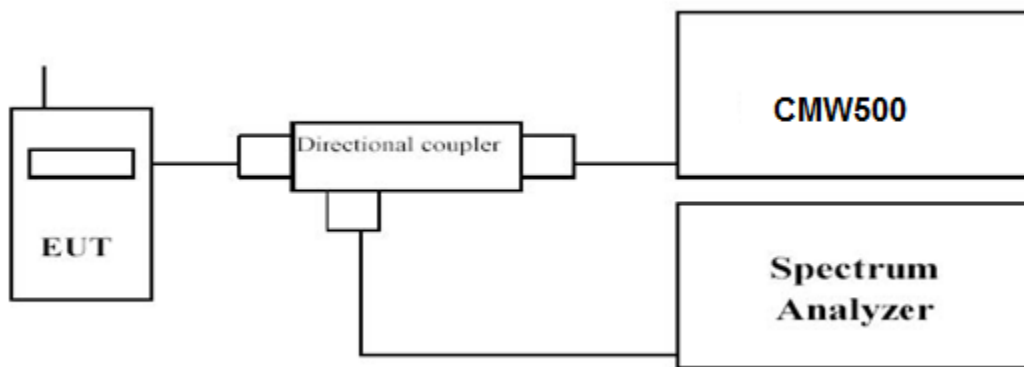

TEST PROCEDURE

The transmitter output was connected to a calibrated coaxial cable and coupler, the other end of which was connected to a spectrum analyzer. The occupied bandwidth was measured with the spectrum analyzer at low, middle and high channel in each band. The -26dBc Emission bandwidth was also measured and recorded.

Set RBW was set to about 1% of emission BW, VBW \geq 3 times RBW.

-26dBc display line was placed on the screen (or 99% bandwidth), the occupied bandwidth is the delta frequency between the two points where the display line intersects the signal trace.

TEST RESULTS

1. please refer to Appendix for 4G_LTE_band_26_814-824MHz: Section 3

3.4. Band Edge compliance

Method Measurement

The EUT was connected to Spectrum Analyzer and Base Station Simulator via power Splitter. The band edge of the lowest and highest channels were measured.

The testing follows KDB 971168 v03 Section 6.0

1. The EUT was connected to spectrum analyzer and system simulator via a power divider.
2. The band edges of low and high channels for the highest RF powers were measured. RBW is set to 10kHz, VBW is set to 30 kHz for LTE Band 14 (769MHz~775MHz). RBW is set to 100 kHz, VBW is set to 300kHz for LTE Band14 (775MHz~788MHz). RBW is set to 10kHz, VBW is set to 30 kHz for LTE Band 14 (799MHz~805MHz).
3. Set spectrum analyzer with RMS detector.
4. The RF fundamental frequency should be excluded against the limit line in the operating frequency band.
5. Checked that all the results comply with the emission limit line.

TEST CONFIGURATION

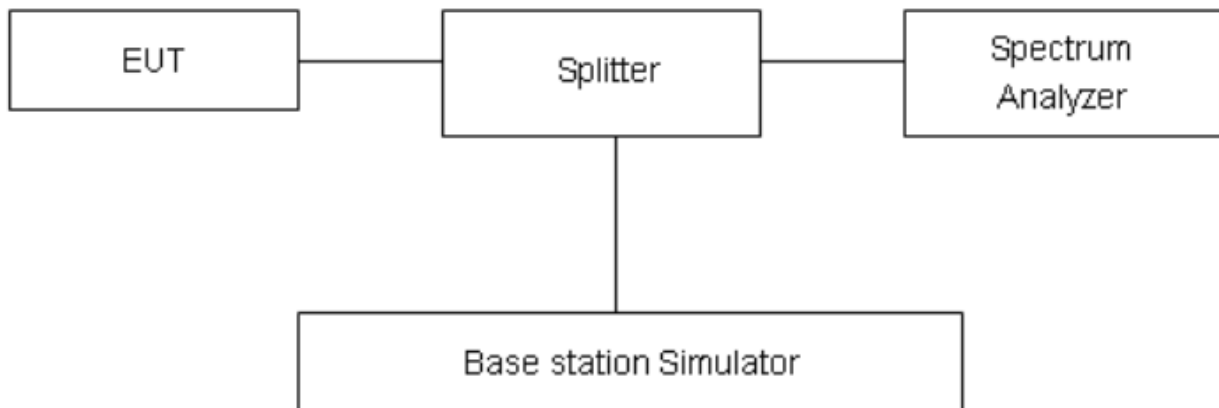

Limits

90.543 Emission limitations (e) For operations in the 758-768 MHz and the 788-798 MHz bands, the power of any emission outside the licensee's frequency band(s) of operation shall be attenuated below the transmitter power (P) within the licensed band(s) of operation, measured in watts, in accordance with the following:

- (1) On all frequencies between 769-775 MHz and 799-805 MHz, by a factor not less than $76 + 10 \log(P)$ dB in a 6.25 kHz band segment, for base and fixed stations.

(2) On all frequencies between 769-775 MHz and 799-805 MHz, by a factor not less than $65 + 10 \log (P)$ dB in a 6.25 kHz band segment, for mobile and portable stations.

(3) On any frequency between 775-788 MHz, above 805 MHz, and below 758 MHz, by at least $43 + 10 \log (P)$ dB.

(4) Compliance with the provisions of paragraphs (e)(1) and (2) of this section is based on the use of measurement instrumentation such that the reading taken with any resolution bandwidth setting should be adjusted to indicate spectral energy in a 6.25 kHz segment.

(5) Compliance with the provisions of paragraph (e)(3) of this section is based on the use of measurement instrumentation employing a resolution bandwidth of 100 kHz or greater. However, in the 100 kHz bands immediately outside and adjacent to the frequency block, a resolution bandwidth of 30 kHz may be employed.

(f) For operations in the 758-775 MHz and 788-805 MHz bands, all emissions including harmonics in the band 1559-1610 MHz shall be limited to -70 dBW/MHz equivalent isotropically radiated power (EIRP) for wideband signals, and -80 dBW EIRP for discrete emissions of less than 700 Hz bandwidth. For the purpose of equipment authorization, a transmitter shall be tested with an antenna that is representative of the type that will be used with the equipment in normal operation.

TEST RESULTS

1. please refer to Appendix for 4G_LTE_band_26_814-824MHz: Section 6

3.5. Spurious Emission

LIMIT

(1) The power of any emission outside a licensee's frequency block shall be attenuated below the transmitter power (P) by at least $43 + 10 \log_{10}(P)$ dB. The limit of emission equal to -13 dBm

(2) For operations in the 763–775 MHz and 793–805 MHz bands, all emissions including harmonics in the band 1559–1610 MHz shall be limited to -70 dBW/MHz equivalent isotropically radiated power (EIRP) for wideband signals, and -80 dBW EIRP for discrete emissions of less than 700 Hz bandwidth. For the purpose of equipment authorization, a transmitter shall be tested with an antenna that is representative of the type that will be used with the equipment in normal operation.

TEST CONFIGURATION

Conducted Spurious Measurement:

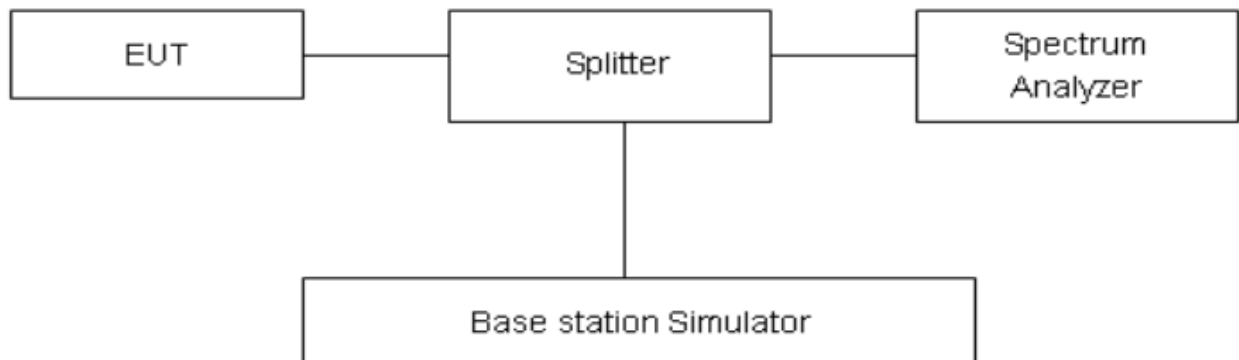

Radiated Spurious Measurement:

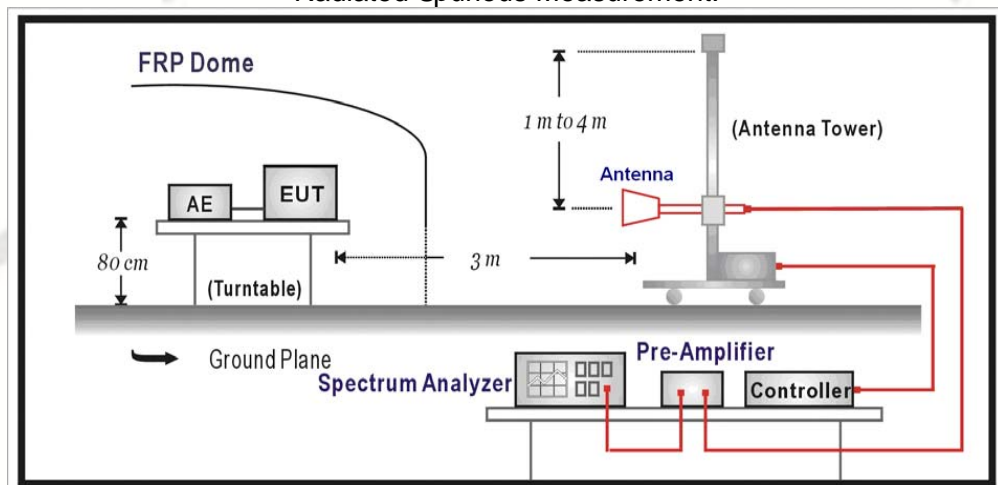

TEST PROCEDURE

The EUT was setup according to EIA/TIA 603D

Conducted Spurious Measurement:

- a. Place the EUT on a bench and set it in transmitting mode.
- b. Connect a low loss RF cable from the antenna port to a spectrum analyzer and CMW500 by a Directional Couple.
- c. EUT Communicate with CMW500 then selects a channel for testing.
- d. Add a correction factor to the display of spectrum, and then test.
- e. The resolution bandwidth of the spectrum analyzer was set sufficient scans were taken to show the out of band Emission if any up to 10th harmonic.

Radiated Spurious Measurement:

- a. The EUT shall be placed at the specified height on a support, and in the position closest to normal use as declared by provider.
- b. The test antenna shall be oriented initially for vertical polarization and shall be chosen to correspond to the frequency of the transmitter
- c. The output of the test antenna shall be connected to the measuring receiver.
- d. The transmitter shall be switched on and the measuring receiver shall be tuned to the frequency of the transmitter under test.
- e. The test antenna shall be raised and lowered through the specified range of height until a maximum signal level is detected by the measuring receiver.
- f. The transmitter shall then be rotated through 360° in the horizontal plane, until the maximum signal level is detected by the measuring receiver.
- g. The test antenna shall be raised and lowered again through the specified range of height until a maximum signal level is detected by the measuring receiver.
- h. The maximum signal level detected by the measuring receiver shall be noted.
- i. The transmitter shall be replaced by a substitution antenna.
- j. The substitution antenna shall be orientated for vertical polarization and the length of the substitution antenna shall be adjusted to correspond to the frequency of the transmitter.
- k. The substitution antenna shall be connected to a calibrated signal generator.
- l. If necessary, the input attenuator setting of the measuring receiver shall be adjusted in order to increase the sensitivity of the measuring receiver.
- m. The test antenna shall be raised and lowered through the specified range of height to ensure that the maximum signal is received.
- n. The input signal to the substitution antenna shall be adjusted to the level that produces a level detected by the measuring receiver, that is equal to the level noted while the transmitter radiated power was measured, corrected for the change of input attenuator setting of the measuring receiver.
- o. The measurement shall be repeated with the test antenna and the substitution antenna orientated for horizontal polarization.
- p. The measure of the effective radiated power is the larger of the two levels recorded at the input to the substitution antenna, corrected for gain of the substitution antenna if necessary.
- q. The resolution bandwidth of the spectrum analyzer was set at 100 kHz for Part 22 and 1MHz for Part 24. The frequency range was checked up to 10th harmonic.
- r. Test site anechoic chamber refer to ANSI C63.

TEST RESULTS**Conducted Measurement:**

1. please refer to Appendix for 4G_LTE_band_26_814-824MHz: Section 6

Radiated Measurement:

1. We were tested all RB Configuration refer 3GPP TS136 521 for each Channel Bandwidth of LTE FDD Band 5; recorded worst case for each Channel Bandwidth of LTE FDD Band 14 and FDD Band 26 QPSK
2. $EIRP = P_{Mea}(dBm) - P_{cl}(dB) + G_a(dBi)$
3. We were not recorded other points as values lower than limits.
4. Margin = EIRP- Limit

LTE FDD Band 26_Channel Bandwidth 1.4MHz_QPSK_Low Channel

Frequency (MHz)	P _{Mea} (dBm)	P _{cl} (dB)	Diatance	G _a Antenna Gain(dB)	Peak EIRP (dBm)	Limit (dBm)	Margin (dB)	Polarization
1649.4	-41.06	4.62	3.00	9.81	-35.87	-13.00	-22.87	H
2444.1	-47.55	5.94	3.00	10.86	-42.63	-13.00	-29.63	H
1649.4	-43.92	4.62	3.00	9.81	-38.73	-13.00	-25.73	V
2444.1	-50.12	5.94	3.00	10.86	-45.20	-13.00	-32.20	V

LTE FDD Band 26_Channel Bandwidth 1.4MHz_QPSK_Middle Channel

Frequency (MHz)	P _{Mea} (dBm)	P _{cl} (dB)	Diatance	G _a Antenna Gain(dB)	EIRP (dBm)	Limit (dBm)	Margin (dB)	Polarization
1638	-39.67	4.63	3.00	9.84	-34.46	-13.00	-21.46	H
2457	-47.13	5.94	3.00	10.86	-42.21	-13.00	-29.21	H
1638	-43.00	4.63	3.00	9.84	-37.79	-13.00	-24.79	V
2457	-47.35	5.94	3.00	10.86	-42.43	-13.00	-29.43	V

LTE FDD Band 26_Channel Bandwidth 1.4MHz_QPSK_High Channel

Frequency (MHz)	P _{Mea} (dBm)	P _{cl} (dB)	Diatance	G _a Antenna Gain(dB)	EIRP (dBm)	Limit (dBm)	Margin (dB)	Polarization
1646.6	-41.04	4.65	3.00	9.90	-35.79	-13.00	-22.79	H
2469.9	-47.19	5.95	3.00	10.91	-42.23	-13.00	-29.23	H
1646.6	-43.62	4.65	3.00	9.90	-38.37	-13.00	-25.37	V
2469.9	-49.52	5.95	3.00	10.91	-44.56	-13.00	-31.56	V

LTE FDD Band 26_Channel Bandwidth 3MHz_QPSK_Low Channel

Frequency (MHz)	P _{Mea} (dBm)	P _{cl} (dB)	Diatance	G _a Antenna Gain(dB)	Peak EIRP (dBm)	Limit (dBm)	Margin (dB)	Polarization
1631	-41.30	4.62	3.00	9.81	-36.11	-13.00	-23.11	H
2446.5	-47.47	5.94	3.00	10.86	-42.55	-13.00	-29.55	H
1631	-43.77	4.62	3.00	9.81	-38.58	-13.00	-25.58	V
2446.5	-50.41	5.94	3.00	10.86	-45.49	-13.00	-32.49	V

LTE FDD Band 26_Channel Bandwidth 3MHz_QPSK_Middle Channel

Frequency (MHz)	P _{Mea} (dBm)	P _{cl} (dB)	Diatance	G _a Antenna Gain(dB)	EIRP (dBm)	Limit (dBm)	Margin (dB)	Polarization
1638	-39.88	4.63	3.00	9.84	-34.67	-13.00	-21.67	H
2457	-47.25	5.94	3.00	10.86	-42.33	-13.00	-29.33	H
1638	-43.14	4.63	3.00	9.84	-37.93	-13.00	-24.93	V
2457	-47.57	5.94	3.00	10.86	-42.65	-13.00	-29.65	V

LTE FDD Band 26_Channel Bandwidth 3MHz_QPSK_High Channel

Frequency (MHz)	P _{Mea} (dBm)	P _{cl} (dB)	Diatance	G _a Antenna Gain(dB)	EIRP (dBm)	Limit (dBm)	Margin (dB)	Polarization
1645	-41.02	4.65	3.00	9.90	-35.77	-13.00	-22.77	H
2467.5	-47.02	5.95	3.00	10.91	-42.06	-13.00	-29.06	H
1645	-43.56	4.65	3.00	9.90	-38.31	-13.00	-25.31	V
2467.5	-49.34	5.95	3.00	10.91	-44.38	-13.00	-31.38	V

LTE FDD Band 26_Channel Bandwidth 5MHz_QPSK_Low Channel

Frequency (MHz)	P _{Mea} (dBm)	P _{cl} (dB)	Diatance	G _a Antenna Gain(dB)	Peak EIRP (dBm)	Limit (dBm)	Margin (dB)	Polarization
1633	-41.13	4.62	3.00	9.81	-35.94	-13.00	-22.94	H
2449.5	-47.35	5.94	3.00	10.86	-42.43	-13.00	-29.43	H
1633	-43.97	4.62	3.00	9.81	-38.78	-13.00	-25.78	V
2449.5	-50.28	5.94	3.00	10.86	-45.36	-13.00	-32.36	V

LTE FDD Band 26_Channel Bandwidth 5MHz_QPSK_Middle Channel

Frequency (MHz)	P _{Mea} (dBm)	P _{cl} (dB)	Diatance	G _a Antenna Gain(dB)	EIRP (dBm)	Limit (dBm)	Margin (dB)	Polarization
1638	-39.74	4.63	3.00	9.84	-34.53	-13.00	-21.53	H
2457	-46.99	5.94	3.00	10.86	-42.07	-13.00	-29.07	H
1638	-43.09	4.63	3.00	9.84	-37.88	-13.00	-24.88	V
2457	-47.46	5.94	3.00	10.86	-42.54	-13.00	-29.54	V

LTE FDD Band 26_Channel Bandwidth 5MHz_QPSK_High Channel

Frequency (MHz)	P _{Mea} (dBm)	P _{cl} (dB)	Diatance	G _a Antenna Gain(dB)	EIRP (dBm)	Limit (dBm)	Margin (dB)	Polarization
1643	-41.22	4.65	3.00	9.90	-35.97	-13.00	-22.97	H
2464.5	-47.08	5.95	3.00	10.91	-42.12	-13.00	-29.12	H
1643	-43.56	4.65	3.00	9.90	-38.31	-13.00	-25.31	V
2464.5	-49.25	5.95	3.00	10.91	-44.29	-13.00	-31.29	V

LTE FDD Band 26_Channel Bandwidth 10MHz_QPSK

Frequency (MHz)	P _{Mea} (dBm)	P _{cl} (dB)	Diatance	G _a Antenna Gain(dB)	Peak EIRP (dBm)	Limit (dBm)	Margin (dB)	Polarization
1638	-41.07	4.62	3.00	9.81	-35.88	-13.00	-22.88	H
2457	-47.25	5.94	3.00	10.86	-42.33	-13.00	-29.33	H
1638	-43.81	4.62	3.00	9.81	-38.62	-13.00	-25.62	V
2457	-50.39	5.94	3.00	10.86	-45.47	-13.00	-32.47	V

3.6. Frequency Stability under Temperature & Voltage Variations

LIMIT

90.539 (c) The frequency stability of mobile, portable, and control transmitters operating in the narrowband segment must be 400 parts per billion or better when AFC is locked to the base station. When AFC is not locked to the base station, the frequency stability must be at least 1.0 ppm for 6.25 kHz, 1.5 ppm for 12.5 kHz (2 channel aggregate), and 2.5 ppm for 25 kHz (4 channel aggregate).

TEST CONFIGURATION

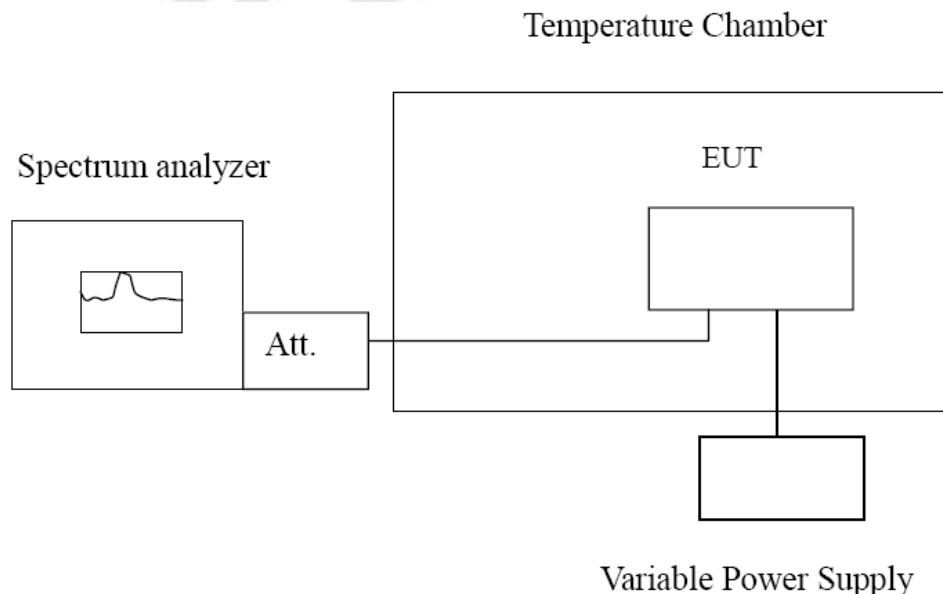

TEST PROCEDURE

The EUT was setup according to EIA/TIA 603D

Frequency Stability under Temperature Variations:

In order to measure the carrier frequency under the condition of AFC lock, it is necessary to make measurements with the EUT in a "call mode". This is accomplished with the use of R&S CMW500 DIGITAL RADIO COMMUNICATION TESTER.

1. Measure the carrier frequency at room temperature.
2. Subject the EUT to overnight soak at -30°C .
3. With the EUT, powered via nominal voltage, connected to the CMW500 and in a simulated call on middle channel for LTE Band 5, measure the carrier frequency. These measurements should be made within 2 minutes of Powering up the EUT, to prevent significant self-warming.
4. Repeat the above measurements at 10°C increments from -30°C to $+50^{\circ}\text{C}$. Allow at least 1.5 hours at each temperature, unpowered, before making measurements.
5. Re-measure carrier frequency at room temperature with nominal voltage. Vary supply voltage from minimum voltage to maximum voltage, in 0.1Volt increments re-measuring carrier frequency at each voltage. Pause at nominal voltage for 1.5 hours unpowered, to allow any self-heating to stabilize, before continuing.
6. Subject the EUT to overnight soak at $+50^{\circ}\text{C}$.
7. With the EUT, powered via nominal voltage, connected to the CMW500 and in a simulated call on the centre channel, measure the carrier frequency. These measurements should be made within 2 minutes of Powering up the EUT, to prevent significant self-warming.
8. Repeat the above measurements at 10°C increments from $+50^{\circ}\text{C}$ to -30°C . Allow at least 1.5 hours at each temperature, unpowered, before making measurements
9. At all temperature levels hold the temperature to $\pm 0.5^{\circ}\text{C}$ during the measurement procedure.

Frequency Stability under Voltage Variations:

Set chamber temperature to 20°C . Use a variable AC power supply / DC power source to power the EUT and set the voltage to rated voltage. Set the spectrum analyzer RBW low enough to obtain the

desired frequency resolution and recorded the frequency.

Reduce the input voltage to specify extreme voltage variation ($\pm 15\%$) and endpoint, record the maximum frequency change.

TEST RESULTS

1. please refer to Appendix for 4G_LTE_band_26_814-824MHz: Section 2

3.7. Modulation Characteristics

Standard Applicable

According to FCC Part 2 §2.1047:

(a) Voice modulated communication equipment. A curve or equivalent data showing the frequency response of the audio modulating circuit over a range of 100 to 5000 Hz shall be submitted. For equipment required to have an audio low-pass filter, a curve showing the frequency response of the filter, or of all circuitry installed between the modulation limiter and the modulated stage shall be submitted.

(b) Equipment which employs modulation limiting. A curve or family of curves showing the percentage of modulation versus the modulation input voltage shall be supplied. The information submitted shall be sufficient to show modulation limiting capability throughout the range of modulating frequencies and input modulating signal levels employed.

(c) Single sideband and independent sideband radiotelephone transmitters which employ a device or circuit to limit peak envelope power. A curve showing the peak envelope power output versus the modulation input voltage shall be supplied. The modulating signals shall be the same in frequency as specified in paragraph (c) of §2.1049 for the occupied bandwidth tests.

(d) Other types of equipment. A curve or equivalent data which shows that the equipment will meet the modulation requirements of the rules under which the equipment is to be licensed.

TEST RESULTS

1. please refer to Appendix for 4G_LTE_band_26_814-824MHz: Section 3

4. Test Setup Photos of the EUT

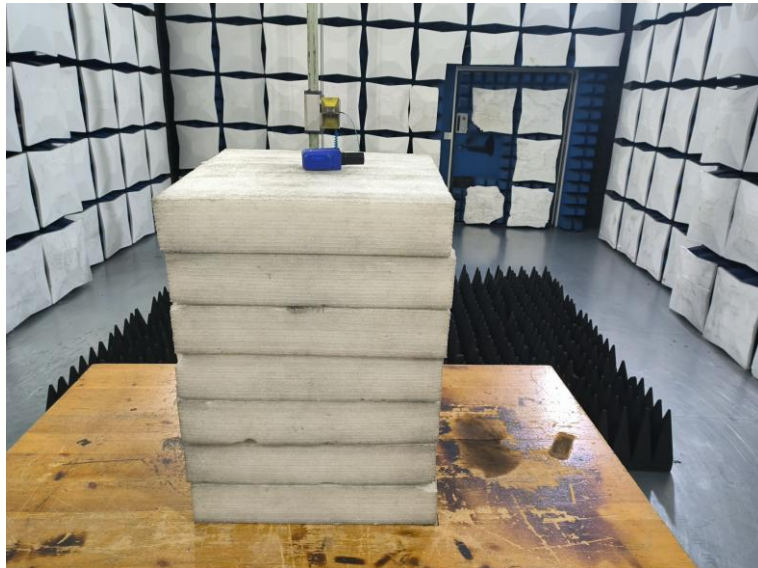

5. External and Internal Photos of the EUT

Reference to the test report No. CTL2405163031-W01

***** End of Report *****