

承认书

SPECIFICATION FOR APPROVAL

(CUSTOMER): Shenzhen Sheng Yijia gift Co., LTD

(CUSTOMER P/N) :

(DESCRIPTION) :

DATE: 2024/6/28

(SPECIFICATION) : G43.5Ultra-thin coil0.08*24*2

深圳市鸿日昇威科技有限公司

HRSW ELECTRONICS CO.,LTD

2nd Floor, Building 1, No. 48 Huanguan Middle Road, Guanlan, Longhua New District, Shenzhen

ADD: 深圳市龙华新区观澜环观中路48号1栋2楼

TEL: 15112254520 FAX: +86-0755-28015170

page: 1/2

SPECIFICATION FOR APPROVAL

1. MECHANICAL DIMENSION (UNIT:mm)

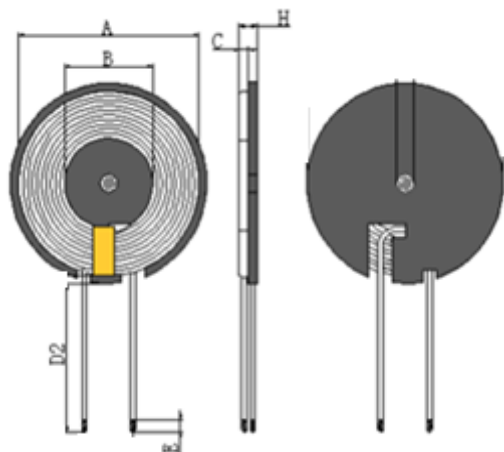

2. SCHEMATICS:

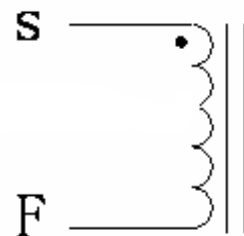

A	B	C	D2	E	H				I
43.5±0.5	20.5±0.5	0.5±0.05	60±2	4±2	1.35MAX				

3. WINDING:

STEP	START-FINISH	WIRE TYPE	TURNS	TAPE	REMARK
N1	S-F	silk-covered wire Ø0.08*24*2P 2UEW	10TS (Ref)		

4. ELECTRICAL SPECIFICATION:

ITEM	L	DCR	temperature
TEST	Coil and diskette	S-F	
CON	100KHz, 0.25V	AT 25°C	
SPEC	6.5uH±10%	67mΩ Max	0-85°C

5. BILF OF MATERIAL:

NO.	ITEM	MATERIAL SPECIFICATION	MANUFACTURER	SGS NO.
1	Silk covered thread 0.08*24*2 strands	Acetone silk-covered wire 0.08*24*2 strands	NANJINGJINNINGCO,LTD	
2	Lead-free tin strip	Lead-free tin strip	QIAODO	
3	magnetic sheet	Ø42.5*0.8	TAIYI CO.,LTD	
4	glue	9999	LIANCHENG CO.,LTD	
5	gummed paper	8mm	CUDAK CO.,LTD	
6	gum	ø41.5*0.1	CUDAK CO.,LTD	

HRSW ELECTRONICS CO.,LTD	PART NO	
	TITLE	G43.5 6.5UH
DRAWN BY	CHECKED BY	APPROVED BY
何伟华	韦立红	韦立红