

I. Plan structure diagram: unit: MM

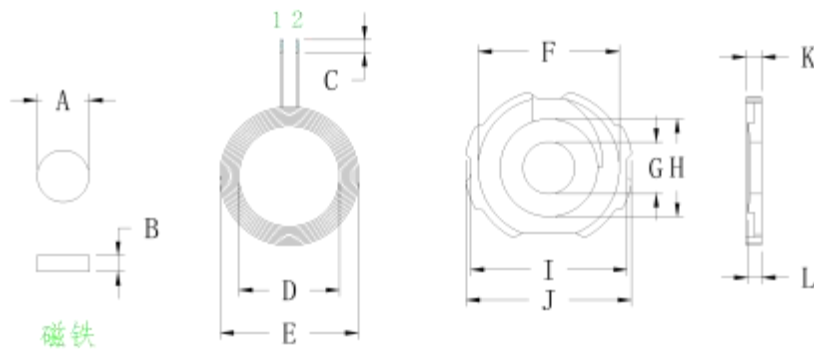

A	7.7 ± 0.05
B	2.0 ± 0.05
C	2 ± 1
D	15 ± 0.2
E	20.5 ± 0.5
F	21 ± 0.1
G	7.7 ± 0.05
H	13.5 ± 0.1
I	23.5 ± 0.2
J	25 ± 0.2
K	2.55 ± 0.1
L	2.25 ± 0.1 中柱高度
M	8 ± 1

2. Product Parameter:

foot position	Line diameter	number of turns	remarks
1 - 2	0.08*24P	12	Hot wind hanging line

3. technical requirement:

1. Fix the line head and tail to prevent line loosening and breaking
2. According to the customer requirements, the long wire shear, tin, tin depth of 2 ± 1 MM
3. Point the appropriate white glue on the soft magnetic sheet, stick the coil, and ensure that the product surface is clean and tidy in the process
4. The soft magnetic sheet used is made with a round hole without damage
5. Additional process (according to customer requirements): Install 7.7x2.0mm magnet in the middle round hole of the finished product and add 14mm

round double-sided adhesive on the back
of the finished product, and pack it back

4. Electrical activity

PIN 1 — 2 = 7.6uH ±0.2UH

parameters:

A Q-value of 35

1. Intance value, Q
value:

The above inductance value is Quanhua 1062A instrument, and 10KHZ/0.3Vrms is the
standard or equivalent instrument.

东莞市聚源精密科技有限公司

Dongguan Juyuan precision Technology Co., LTD

Fourth floor, Building K, Shijie Village Central Industrial Zone, No. 75,
Dongfeng South Road, Shijie Village, Shijie Town, Dongguan, Guangdong

Q value is Quanhua 1062A instrument, 100KHZ/0.3Vrms as the standard or equivalent instrument

V. List of Materials:

order number	name	material quality	supplier	remarks
1	Hot wind hanging line	0.08X24P	Vihan or equivalent	
2	magnetic sheet	G 25 soft substrate	Tiantong or equivalent	
3	tin	High temperature environmental protection	Thousand islands or equivalent	
4	alban	BY 882	Treasure moon or equivalent	
5	Strong magnetic force	7.7 * 2 (Strength greater than 3000GS)	United wins or equates	Additional processes , according to the customer's requirements
6	double faced adhesive tape	diameter 14mm	Honghui or d	
