

# FCC TEST REPORT

## FCC ID: 2BCQA-G65

Product	:	Phone
Model Name	:	G65
Brand	:	N/A
Report No.	:	NCT24002161E-FC07
<b>Prepared for</b>		
Clover Industrial Co.,Ltd		
Building 4, Hengchangrong High-tech Industrial Park, Shangnan East Road, Hongtian,Huangpu Community, Xinqiao Street, Baoan District, Shenzhen		
<b>Prepared by</b>		
Shenzhen NCT Testing Technology Co., Ltd.		
A101&2F B2, Fuqiao 6th Area, Xintian Community, Fuhai Street, Baoan District, Shenzhen, People's Republic of China		
TEL: 400-8868-419		
FAX: 86-755-27790922		

## 1 Test Result Certification

Applicant's name : Clover Industrial Co.,Ltd  
Address : Building 4, Hengchangrong High-tech Industrial Park, Shangnan  
East Road, Hongtian, Huangpu Community, Xinqiao Street,  
Baoan District, Shenzhen  
Manufacture's name : Clover Industrial Co.,Ltd  
Address : Building 4, Hengchangrong High-tech Industrial Park, Shangnan  
EastRoad, Hongtian, Huangpu Community, Xingjiao Street,  
Baoan District, shenzhen  
Product name : Phone  
Model name : G65  
Standards : 47 CFR FCC Part 22 Subpart H ,47 CFR FCC Part 24 Subpart E,  
47 CFR FCC Part 27, 47 CFR FCC Part 290, ANSI C63.26-2015,  
ANSI TIA-603-E-2016, KDB 971168 D01 Power Meas License Digital  
Systems v03r01  
Test Date : Nov. 23, 2023 to Dec. 18, 2023  
Date of Issue : Dec. 25, 2023  
Test Result : Pass

This device described above has been tested by NCT, and the test results show that the equipment under test (EUT) is in compliance with the FCC requirements. And it is applicable only to the tested sample identified in the report.

This report shall not be reproduced except in full, without the written approval of NCT, this document may be altered or revised by NCT, personal only, and shall be noted in the revision of the document.

Test Engineer:



Keven Wu / Engineer

Technical Manager:



Henry Wang / Manager

**TABLE OF CONTENTS**

**1 Test Result Certification ..... 2**

**2. General Description Of Eut ..... 4**

**1. Facilities and Accreditations ..... 6**

    1.1. TEST FACILITY .....6

    1.2. DESCRIPTION OF TEST CHANNELS AND TEST MODES .....7

    1.3. EQUIPMENT MODIFICATIONS .....11

**2. Summary Of Test Requirements And Results..... 12**

**3. MEASUREMENT INSTRUMENTS ..... 17**

**4. EFFECTIVE (ISOTROPIC) RADIATED POWER ..... 19**

    4.1. CONDUCTED OUTPUT POWER .....19

    4.2. EFFECTIVE (ISOTROPIC) RADIATED POWER .....19

**5. SPURIOUS EMISSION (Conducted and Radiated) ..... 20**

    5.1. MEASUREMENT RESULT (PRE-MEASUREMENT).....20

**6. Occupied Bandwidth and Emission Bandwidth ..... 29**

**7. Band Edge..... 33**

**8. Frequency Stability..... 35**

    8.1. MEASUREMENT RESULT (WORST).....36

**15 APPENDIX I -- TEST SETUP PHOTOGRAPH..... 37**

**16 APPENDIX II -- EUT PHOTOGRAPH..... 38**

## 2. General Description Of Eut

<b>Equipment Type:</b>	Phone
<b>Hardware version:</b>	K20-V2.0k
<b>Software version:</b>	N/A
<b>LTE Support Band:</b>	E-UTRA Bands: <input checked="" type="checkbox"/> E-UTRA Band 2 <input checked="" type="checkbox"/> E-UTRA Band 4 <input checked="" type="checkbox"/> E-UTRA Band 5 <input checked="" type="checkbox"/> E-UTRA Band 12 <input checked="" type="checkbox"/> E-UTRA Band 13 <input checked="" type="checkbox"/> E-UTRA Band 17 <input checked="" type="checkbox"/> E-UTRA Band 25 <input checked="" type="checkbox"/> E-UTRA Band 26 <input checked="" type="checkbox"/> E-UTRA Band 41 <input checked="" type="checkbox"/> E-UTRA Band 66 <input checked="" type="checkbox"/> E-UTRA Band 71
<b>Antenna Type:</b>	PIFA Antenna
<b>Modulation Type:</b>	<input checked="" type="checkbox"/> QPSK <input checked="" type="checkbox"/> 16QAM <input checked="" type="checkbox"/> 64QAM(Downlink Only)
<b>Antenna gain:</b>	E-UTRA Band 2: 0.94dBi E-UTRA Band 4: -0.5dBi E-UTRA Band 5: -4.76dBi E-UTRA Band 12: -3.3dBi E-UTRA Band 13: -5.13dBi E-UTRA Band 17: -4.75dBi E-UTRA Band 25: 0.94dBi E-UTRA Band 26: -5.36dBi E-UTRA Band 41: 0.19dBi E-UTRA Band 66: 0 dBi E-UTRA Band 71: -3.3dBi
<b>Adapter Information:</b>	Battery Model: 456797 3.8V by Rechargeable Li-ion Battery, 4000mAh
<b>Extreme Vol. Limits:</b>	DC 3.4V to 4.2V (Normal: DC 3.8V)

**Table 2.1 The Basic Technical Specification for Working BAND(S).**

OPERATION BAND(S)	Power Class	Mod.	Max ERP(dBm)
E-UTRA BAND 2	Class 3	QPSK	/
E-UTRA BAND 2	Class 3	16QAM	/
E-UTRA BAND 4	Class 3	QPSK	/
E-UTRA BAND 4	Class 3	16QAM	/
E-UTRA BAND 5	Class 3	QPSK	/
E-UTRA BAND 5	Class 3	16QAM	/
E-UTRA BAND 12	Class 3	QPSK	/
E-UTRA BAND 12	Class 3	16QAM	/
E-UTRA BAND 13	Class 3	QPSK	/
E-UTRA BAND 13	Class 3	16QAM	/
E-UTRA BAND 17	Class 3	QPSK	/
E-UTRA BAND 17	Class 3	16QAM	/
E-UTRA BAND 25	Class 3	QPSK	/
E-UTRA BAND 25	Class 3	16QAM	/
E-UTRA BAND 26	Class 3	QPSK	/
E-UTRA BAND 26	Class 3	16QAM	/
E-UTRA BAND 41	Class 3	QPSK	/
E-UTRA BAND 41	Class 3	16QAM	/
E-UTRA BAND 66	Class 3	QPSK	/
E-UTRA BAND 66	Class 3	16QAM	/
E-UTRA BAND 71	Class 3	QPSK	/
E-UTRA BAND 71	Class 3	16QAM	/

# 1. Facilities and Accreditations

## 1.1. Test Facility

### Site Description

EMC Lab. : Accredited by CNAS, 2022-09-27

The certificate is valid until 2028.01.07

The Laboratory has been assessed and proved to be in compliance with CNAS-CL01:2006 (identical to ISO/IEC 17025:2017)

The Certificate Registration Number is L8251

Designation Number: CN1347

Test Firm Registration Number: 894804

Accredited by A2LA, June 14, 2023

The Certificate Registration Number is 6837.01

Accredited by Industry Canada, November 09, 2018

The Conformity Assessment Body Identifier is CN0150

Company Number: 30806

Name of Firm : Shenzhen NCT Testing Technology Co., Ltd.

Site Location : A101&2F B2, Fuqiao 6th Area, Xintian Community, Fuhai Street, Baoan District, Shenzhen, People's Republic of China

## 1.2. Description Of Test Channels And Test Modes

### Test channels:

E-UTRA Band 2					
Test Frequency ID	Bandwidth[MHz]	N <sub>UL</sub>	Frequency of Uplink [MHz]	N <sub>DL</sub>	Frequency of Downlink[MHz]
Low Range	1.4	18607	1850.7	607	1930.7
	3	18615	1851.5	615	1931.5
	5	18625	1852.5	625	1932.5
	10	18650	1855	650	1935
	15	18675	1857.5	675	1937.5
	20	18700	1860	700	1940
Mid Range	1.4/3/5/10/15/20	18900	1880	900	1960
High Range	1.4	19193	1909.3	1193	1989.3
	3	19185	1908.5	1185	1988.5
	5	19175	1907.5	1175	1987.5
	10	19150	1905	1150	1985
	15	19125	1902.5	1125	1982.5
	20	19100	1900	1100	1980

E-UTRA Band 4					
Test Frequency ID	Bandwidth[MHz]	N <sub>UL</sub>	Frequency of Uplink [MHz]	N <sub>DL</sub>	Frequency of Downlink[MHz]
Low Range	1.4	19957	1710.7	1957	2110.7
	3	19965	1711.5	1965	2111.5
	5	19975	1712.5	1975	2112.5
	10	20000	1715	2000	2115
	15	20025	1717.5	2025	2117.5
	20	20050	1720	2050	2120
Mid Range	1.4/3/5/10/15/20	20175	1732.5	2175	2132.5
High Range	1.4	20393	1754.3	2393	2154.3
	3	20385	1753.5	2385	2153.5
	5	20375	1752.5	2375	2152.5
	10	20350	1750	2350	2150
	15	20325	1747.5	2325	2147.5
	20	20300	1745	2300	2145

E-UTRA Band 5					
Test Frequency ID	Bandwidth[MHz]	N <sub>UL</sub>	Frequency of Uplink [MHz]	N <sub>DL</sub>	Frequency of Downlink[MHz]
Low Range	1.4	20407	824.7	2407	869.7
	3	20415	825.5	2415	870.5
	5	20425	826.5	2425	871.5
	10	20450	829	2450	874
Mid Range	1.4/3/5/10	20525	836.5	2525	881.5
High Range	1.4	20643	848.3	2643	893.3
	3	20635	847.5	2635	892.5
	5	20625	846.5	2625	891.5
	10	20600	844	2600	889

E-UTRA Band 12					
Test Frequency ID	Bandwidth[MHz]	N <sub>UL</sub>	Frequency of Uplink [MHz]	N <sub>DL</sub>	Frequency of Downlink[MHz]
Low Range	1.4	23017	699.7	5017	729.7
	3	23025	700.5	5025	730.5
	5	23035	701.5	5035	731.5
	10	23060	704	5060	734
Mid Range	1.4/3/5/10	23095	707.5	5095	737.5
High Range	1.4	23173	715.3	5173	745.3
	3	23165	714.5	5165	744.5
	5	23155	713.5	5155	743.5
	10	23130	711	5130	741

E-UTRA Band 13					
Test Frequency ID	Bandwidth[MHz]	N <sub>UL</sub>	Frequency of Uplink [MHz]	N <sub>DL</sub>	Frequency of Downlink[MHz]
Low Range	5	23205	779.5	5205	748.5
	10	23230	782	5230	751
Mid Range	5/10	23230	782	5230	751
High Range	5	23255	784.5	5255	753.5
	10	23230	782	5230	751

E-UTRA Band 17					
Test Frequency ID	Bandwidth[MHz]	N <sub>UL</sub>	Frequency of Uplink [MHz]	N <sub>DL</sub>	Frequency of Downlink[MHz]
Low Range	5	23755	706.5	5755	736.5
	10	23780	709	5780	739
Mid Range	5/10	23790	710	5790	740
High Range	5	23825	713.5	5825	743.5
	10	23800	711	5800	741

E-UTRA Band 25					
Test Frequency ID	Bandwidth[MHz]	N <sub>UL</sub>	Frequency of Uplink [MHz]	N <sub>DL</sub>	Frequency of Downlink[MHz]
Low Range	1.4	26047	1850.7	8047	1930.7
	3	26055	1851.5	8055	1931.5
	5	26065	1852.5	8065	1932.5
	10	26090	1855	8090	1935
	15	26115	1857.5	8115	1937.5
	20	26140	1860	8140	1940
Mid Range	1.4/3/5/10/15/20	26365	1882.5	8365	1962.5
High Range	1.4	26683	1914.3	8683	1994.3
	3	26675	1913.5	8675	1993.5
	5	26665	1912.5	8665	1992.5
	10	26640	1910	8640	1990
	15	26615	1907.5	8615	1987.5
	20	26590	1905	8590	1985



E-UTRA Band 26					
Test Frequency ID	Bandwidth[MHz]	N <sub>UL</sub>	Frequency of Uplink [MHz]	N <sub>DL</sub>	Frequency of Downlink[MHz]
Low Range	1.4	26697	814.7	8697	859.7
	3	26705	815.5	8705	860.5
	5	26715	816.5	8715	861.5
	10	26740	819	8740	864
	15	26765	821.5	8765	866.5
Mid Range	1.4/3/5/10/15	26865	831.5	8865	876.5
High Range	1.4	27033	848.3	9033	893.3
	3	27025	847.5	9025	892.5
	5	27015	846.5	9015	891.5
	10	26990	844	8990	889
	15	26965	841.5	8965	886.5

E-UTRA Band 41					
Test Frequency ID	Bandwidth[MHz]	N <sub>UL</sub>	Frequency of Uplink [MHz]	N <sub>DL</sub>	Frequency of Downlink[MHz]
Low Range	5	39675	2498.5	39675	2498.5
	10	39700	2501	39700	2501
	15	39725	2503.5	39725	2503.5
	20	39750	2506	39750	2506
Mid Range	5/10/15/20	40620	2593	40620	2593
High Range	5	41565	2687.5	41565	2687.5
	10	41540	2685	41540	2685
	15	41515	2682.5	41515	2682.5
	20	41490	2680	41490	2680

Test Frequency ID	Bandwidth [MHz]	NUL	Frequency of Uplink [MHz]	NDL	Frequency of Downlink [MHz]
Low Range	1.4	131979	1710.7	66443	2110.7
	3	131987	1711.5	66451	2111.5
	5	131997	1712.5	66461	2112.5
	10	132022	1715	66486	2115
	15	132047	1717.5	66511	2117.5
	20	132072	1720	66536	
Mid Range Tx1	1.4/3/5/10/15/20	132322	1745	66786	
Mid Range	1.4/3/5/10/15/20	132422	1755	66886	2155
Paired High Range2	1.4	132665	1779.3	67129	2179.3
	3	132657	1778.5	67121	2178.5
	5	132647	1777.5	67111	2177.5
	10	132622	1775	67086	
	15	132597	1772.5	67061	2172.5
	20	132572	1770	67036	2170
High Range3	1.4	NA	NA	67329	2199.3
	3	NA	NA	67321	2198.5
	5	NA	NA	67311	2197.5
	10	NA	NA	67286	2195
	15	NA	NA	67261	2192.5
	20	NA	NA	67236	2190

Note 1: Applicable for transmitter testing.  
 Note 2: Applicable if UL is configured on the CC.  
 Note 3: Applicable if no UL is configured on the CC.

E-UTRA Band 71					
Test Frequency ID	Bandwidth[MHz]	N <sub>UL</sub>	Frequency of Uplink [MHz]	N <sub>DL</sub>	Frequency of Downlink[MHz]
Low Range	5	133147	665.5	68611	619.5
	10	133172	668	68636	622
	15	133197	670.5	68661	624.5
	20	133222	673	68686	627
Mid Range	5/10/15/20	133297	680.5	68761	634.5
High Range	5	133322	683	68786	637
	10	133447	695.5	68911	649.5
	15	133422	693	68886	647
	20	133397	690.5	68861	644.5

- Note 1.both QPSK&16QAM modulation has been measured;  
 2. The worst condition was recorded in the test report if no other modes test data.

### **1.3. Equipment Modifications**

Not available for this EUT intended for grant.

## 2. Summary Of Test Requirements And Results

### E-UTRA Band 2(Transmit: 1850 MHz -1910 MHz; Receive: 1930 MHz-1990 MHz):

Test Item	FCC Rule No.	Requirements	Judgement
Effective (Isotropic) Radiated Power	§2.1046, §24.232	EIRP $\leq$ 2W	Pass
Peak-Average Ratio	§2.1046, §24.232	FCC: Limit $\leq$ 13dB	Pass
Modulation Characteristics	§2.1047	Digital modulation	N/A
Occupied Bandwidth	§2.1049	OBW: No limit.	Pass
Emission Bandwidth	22.917(b)	EBW: No limit.	Pass
Band Edges Compliance	§2.1051 §24.238(a)	$\leq$ -13 dBm/1%*EBW, in 1 MHz bands immediately outside and adjacent to the frequency block.	Pass
Spurious Emission at Antenna Terminals	§2.1051, §24.238	FCC: $\leq$ -13 dBm/100 kHz, from 9 kHz to 10 <sup>th</sup> harmonics but outside authorized operating frequency ranges.	Pass
Field Strength of Spurious Radiation	§2.1053, §24.238	FCC: $\leq$ -13 dBm/1 MHz.	Pass
Frequency Stability	§2.1055, §22.355	the fundamental emissions stay within the authorized bands of operation. (2.5ppm)	Pass

Note: For the Judgement, the "N/A" denotes "not applicable", the "N/T"de notes "not tested".

### E-UTRA Band 4(Transmit: 1710 MHz - 1755 MHz; Receive: 2110 MHz- 2155 MHz):

Test Item	FCC Rule No.	Requirements	Judgement
Effective (Isotropic) Radiated Power	§2.1046, §27.5(d)	EIRP $\leq$ 1W	Pass
Peak-Average Ratio	§2.1046, §27.5(d)	FCC: Limit $\leq$ 13dB	Pass
Modulation Characteristics	§2.1047	Digital modulation	N/A
Occupied Bandwidth	§2.1049	OBW: No limit.	Pass
Emission Bandwidth	§2.1049	EBW: No limit.	Pass
Band Edges Compliance	§2.1051 §27.53(h)	$\leq$ -13 dBm/1%*EBW, in 1 MHz bands immediately outside and adjacent to the frequency block.	Pass
Spurious Emission at Antenna Terminals	§2.1051 §27.53(h)	FCC: $\leq$ -13 dBm/100 kHz, from 9 kHz to 10 <sup>th</sup> harmonics but outside authorized operating frequency ranges.	Pass
Field Strength of Spurious Radiation	§2.1053, §22.917	FCC: $\leq$ -13 dBm/100 kHz.	Pass
Frequency Stability	§2.1055, §22.355	the fundamental emissions stay within the authorized bands of operation. (2.5ppm)	Pass

Note: For the Judgement, the "N/A" denotes "not applicable", the "N/T"de notes "not tested".

**E-UTRA Band 5(Transmit: 824 MHz - 849 MHz; Receive: 869 MHz - 894 MHz):**

Test Item	FCC Rule No.	Requirements	Judgement
Effective (Isotropic) Radiated Power	§2.1046, §22.913	ERP ≤ 7W	Pass
Peak-Average Ratio	§2.1046, §27.5(d)	FCC: Limit ≤ 13dB	Pass
Modulation Characteristics	§2.1047	Digital modulation	N/A
Occupied Bandwidth	§2.1049	OBW: No limit.	Pass
Emission Bandwidth	§2.1049	EBW: No limit.	Pass
Band Edges Compliance	§2.1051 §22.917	≤ -13 dBm/1%*EBW, in 1 MHz bands immediately outside and adjacent to the frequency block.	Pass
Spurious Emission at Antenna Terminals	§2.1051 §22.917	FCC: ≤ -13 dBm/100 kHz, from 9 kHz to 10th harmonics but outside authorized operating frequency ranges.	Pass
Field Strength of Spurious Radiation	§2.1053, §22.917	FCC: ≤ -13 dBm/100 kHz.	Pass
Frequency Stability	§2.1055, §22.355	the fundamental emissions stay within the authorized bands of operation. (2.5ppm)	Pass

Note: For the Judgement, the "N/A" denotes "not applicable", the "N/T" denotes "not tested".

**E-UTRA Band 12(Transmit: 699 MHz – 716 MHz; Receive: 729 MHz – 746 MHz):**

Test Item	FCC Rule No.	Requirements	Judgement
Effective (Isotropic) Radiated Power	§2.1046, §27.50(c)	EIRP ≤ 3W	Pass
Peak-Average Ratio	§2.1046, §27.50(c)	FCC: Limit ≤ 13dB	Pass
Modulation Characteristics	§2.1047	Digital modulation	N/A
Occupied Bandwidth	§2.1049	OBW: No limit.	Pass
Emission Bandwidth	§2.1049	EBW: No limit.	Pass
Band Edges Compliance	§2.1051 §27.53(g)	≤ -13 dBm/1%*EBW, in 1 MHz bands immediately outside and adjacent to the frequency block.	Pass
Spurious Emission at Antenna Terminals	§2.1051 §27.53(g)	FCC: ≤ -13 dBm/100 kHz, from 9 kHz to 10th harmonics but outside authorized operating frequency ranges.	Pass
Field Strength of Spurious Radiation	§2.1053, §27.53(g)	FCC: ≤ -13 dBm/100 kHz.	Pass
Frequency Stability	§2.1055, §27.54	the fundamental emissions stay within the authorized bands of operation. (2.5ppm)	Pass

Note: For the Judgement, the "N/A" denotes "not applicable", the "N/T" denotes "not tested".

**E-UTRA Band 13(Transmit: 777 MHz - 787 MHz; Receive: 746 MHz – 756 MHz):**

Test Item	FCC Rule No.	Requirements	Judgement
Effective (Isotropic) Radiated Power	§2.1046, §27.50(b)	EIRP $\leq$ 3W	Pass
Peak-Average Ratio	§2.1046, §27.5(b)	FCC: Limit $\leq$ 13dB	Pass
Modulation Characteristics	§2.1047	Digital modulation	N/A
Occupied Bandwidth	§2.1049	OBW: No limit.	Pass
Emission Bandwidth	§2.1049	EBW: No limit.	Pass
Band Edges Compliance	§2.1051 §27.53(c)	$\leq$ -13 dBm/1%*EBW, in 1 MHz bands immediately outside and adjacent to the frequency block.	Pass
Spurious Emission at Antenna Terminals	§2.1051 §27.53(c)	FCC: $\leq$ -13 dBm/100 kHz, from 9 kHz to 10th harmonics but outside authorized operating frequency ranges.	Pass
Field Strength of Spurious Radiation	§2.1053, §27.53(c)	FCC: $\leq$ -13 dBm/100 kHz.	Pass
Frequency Stability	§2.1055, §27.54	the fundamental emissions stay within the authorized bands of operation. (2.5ppm)	Pass
Note: For the Judgement, the "N/A" denotes "not applicable", the "N/T" denotes "not tested".			

**E-UTRA Band 17(Transmit: 704 MHz - 716 MHz; Receive: 734 MHz – 746 MHz):**

Test Item	FCC Rule No.	Requirements	Judgement
Effective (Isotropic) Radiated Power	§2.1046, §27.5(d)	EIRP $\leq$ 1W	Pass
Peak-Average Ratio	§2.1046, §27.5(d)	FCC: Limit $\leq$ 13dB	Pass
Modulation Characteristics	§2.1047	Digital modulation	N/A
Occupied Bandwidth	§2.1049	OBW: No limit.	Pass
Emission Bandwidth	§2.1049	EBW: No limit.	Pass
Band Edges Compliance	§2.1051 §27.53(h)	$\leq$ -13 dBm/1%*EBW, in 1 MHz bands immediately outside and adjacent to the frequency block.	Pass
Spurious Emission at Antenna Terminals	§2.1051 §27.53(h)	FCC: $\leq$ -13 dBm/100 kHz, from 9 kHz to 10th harmonics but outside authorized operating frequency ranges.	Pass
Field Strength of Spurious Radiation	§2.1053, §22.917	FCC: $\leq$ -13 dBm/100 kHz.	Pass
Frequency Stability	§2.1055, §22.355	the fundamental emissions stay within the authorized bands of operation. (2.5ppm)	Pass
Note: For the Judgement, the "N/A" denotes "not applicable", the "N/T" denotes "not tested".			

**E-UTRA Band 25(Transmit: 1850 MHz – 1915 MHz Receive: 1930 MHz – 1995 MHz):**

Test Item	FCC Rule No.	Requirements	Judgement
Effective (Isotropic) Radiated Power	§2.1046, §24.232	EIRP $\leq$ 2W	Pass
Peak-Average Ratio	§2.1046, §24.232	FCC: Limit $\leq$ 13dB	Pass
Modulation Characteristics	§2.1047	Digital modulation	N/A
Occupied Bandwidth	§2.1049	OBW: No limit.	Pass
Emission Bandwidth	§2.1049	EBW: No limit.	Pass
Band Edges Compliance	§2.1051 §24.238	$\leq$ -13 dBm/1%*EBW, in 1 MHz bands immediately outside and adjacent to the frequency block.	Pass
Spurious Emission at Antenna Terminals	§2.1051 §24.238	FCC: $\leq$ -13 dBm/100 kHz, from 9 kHz to 10th harmonics but outside authorized operating frequency ranges.	Pass
Field Strength of Spurious Radiation	§2.1055, §24.235	FCC: $\leq$ -13 dBm/100 kHz.	Pass
Frequency Stability	§2.105, §24.238	the fundamental emissions stay within the authorized bands of operation. (2.5ppm)	Pass

Note: For the Judgement, the "N/A" denotes "not applicable", the "N/T"de notes "not tested".

**E-UTRA Band 26(Transmit: 814 MHz - 824MHz; Receive: 859 MHz – 869 MHz):**

Test Item	FCC Rule No.	Requirements	Judgement
Effective (Isotropic) Radiated Power	§2.1046, §90.635	EIRP $\leq$ 100W	Pass
Peak-Average Ratio	§2.1046	FCC: Limit $\leq$ 13dB	Pass
Modulation Characteristics	§2.1047	Digital modulation	N/A
Occupied Bandwidth	§2.1049	OBW: No limit.	Pass
Emission Bandwidth	§2.1049	EBW: No limit.	Pass
Band Edges Compliance	§2.1051 §90.669	$\leq$ -13 dBm/1%*EBW, in 1 MHz bands immediately outside and adjacent to the frequency block.	Pass
Spurious Emission at Antenna Terminals	§2.1051 §90.669	FCC: $\leq$ -13 dBm/100 kHz, from 9 kHz to 10th harmonics but outside authorized operating frequency ranges.	Pass
Field Strength of Spurious Radiation	§2.1053, §90.669	FCC: $\leq$ -13 dBm/100 kHz.	Pass
Frequency Stability	§2.1055, §90.669	the fundamental emissions stay within the authorized bands of operation. (2.5ppm)	Pass

Note: For the Judgement, the "N/A" denotes "not applicable", the "N/T"de notes "not tested".

**E-UTRA Band 41(Transmit: 2496 MHz - 2690 MHz; Receive: 2496 MHz - 2690 MHz):**

Test Item	FCC Rule No.	Requirements	Judgement
Effective (Isotropic) Radiated Power	§2.1046, §27.50(h)	EIRP ≤ 2W(33dBm)	Pass
Peak-Average Ratio	§2.1046, §27.5(d)	FCC: Limit≤ 13dB	Pass
Modulation Characteristics	§2.1047	Digital modulation	N/A
Occupied Bandwidth	§2.1049	OBW: No limit. EBW: No limit.	Pass
Emission Bandwidth	§2.1049	EBW: No limit.	Pass
Band Edges Compliance	§27.53(m)(4)	§27.53(m)(4)	Pass
Spurious Emission at Antenna Terminals	§27.53(m)(4)	-25dBm/MHz	Pass
Field Strength of Spurious Radiation	§2.1053, §27.53(m)(4)	-25dBm/MHz	Pass
Frequency Stability	§2.1055, §27.54	the fundamental emissions stay within the authorized bands of operation. (2.5ppm)	Pass

Note: For the Judgement, the "N/A" denotes "not applicable", the "N/T"de notes "not tested".

**E-UTRA Band 66(Transmit: 1710 MHz – 1780 MHz; Receive: 2110 MHz – 2200 MHz):**

Test Item	FCC Rule No.	Requirements	Judgement
Effective (Isotropic) Radiated Power	§2.1046, §27.50(h)	EIRP ≤ 2W(33dBm)	Pass
Peak-Average Ratio	§2.1046, §27.5(d)	FCC: Limit≤ 13dB	Pass
Modulation Characteristics	§2.1047	Digital modulation	N/A
Occupied Bandwidth	§2.1049	OBW: No limit. EBW: No limit.	Pass
Emission Bandwidth	§2.1049	EBW: No limit.	Pass
Band Edges Compliance	§27.53(m)(4)	§27.53(m)(4)	Pass
Spurious Emission at Antenna Terminals	§27.53(m)(4)	-25dBm/MHz	Pass
Field Strength of Spurious Radiation	§2.1053, §27.53(m)(4)	-25dBm/MHz	Pass
Frequency Stability	§2.1055, §27.54	the fundamental emissions stay within the authorized bands of operation. (2.5ppm)	Pass

Note: For the Judgement, the "N/A" denotes "not applicable", the "N/T"de notes "not tested".



**E-UTRA Band 71(Transmit:663 MHz – 698 MHz; Receive:617 MHz – 652 MHz):**

Test Item	FCC Rule No.	Requirements	Judgement
Effective (Isotropic) Radiated Power	§2.1046, §27.50(h)	EIRP ≤ 2W(33dBm)	Pass
Peak-Average Ratio	§2.1046, §27.5(d)	FCC: Limit≤ 13dB	Pass
Modulation Characteristics	§2.1047	Digital modulation	N/A
Occupied Bandwidth	§2.1049	OBW: No limit. EBW: No limit.	Pass
Emission Bandwidth	§2.1049	EBW: No limit.	Pass
Band Edges Compliance	§27.53(m)(4)	§27.53(m)(4)	Pass
Spurious Emission at Antenna Terminals	§27.53(m)(4)	-25dBm/MHz	Pass
Field Strength of Spurious Radiation	§2.1053, §27.53(m)(4)	-25dBm/MHz	Pass
Frequency Stability	§2.1055, §27.54	the fundamental emissions stay within the authorized bands of operation. (2.5ppm)	Pass

Note: For the Judgement, the "N/A" denotes "not applicable", the "N/T" denotes "not tested".

**3. Measurement Instruments**

## RF Conducted Test

Name of Equipment	Manufacturer	Model	Serial No.	Characteristics	Last Calibration	Calibration Interval
MXG Signal Analyzer	Agilent	N9020A	SER MY5111038	10Hz-30GHz	Aug.17, 2023	1 Year
Coaxial Cable	CDS	79254	46107086	10Hz-30GHz	Aug.17, 2023	1 Year
Power Meter	Anritsu	ML2495A	0949003	300MHz-40GHz	Aug.17, 2023	1 Year
Power Sensor	Anritsu	MA2411B	0917017	300MHz-40GHz	Aug.17, 2023	1 Year
Signal Analyzer 40GHZ	Rohde&Schwarz	FSV40	101456	10Hz-40GHz	Aug.17, 2023	1 Year
Wireless Communication Tester	Rohde&Schwarz	CMW500	134930	/	Aug.17, 2023	1 year

Remark: The temporary antenna connector is soldered on the PCB board in order to perform conducted tests and this temporary antenna connector is listed in the equipment list.

Name of Equipment	Manufacturer	Model	Serial No.	Characteristics	Last Calibration	Calibration Interval
EMI Test Receiver	Rohde&Schwarz	ESCI7	101671	9KHz-7GHz	Aug. 17,2023	1 Year
Loop Antenna	Schwarzbeck	FMZB 1519B	192	9 KHz -30MHz	Aug. 17,2023	1 Year
Bilog Antenna	SCHWARZBEC K	VULB9160	9160-3355	25MHz-2GHz	Aug. 17,2023	1 Year
Preamplifier (low frequency)	SCHWARZBEC K	BBV 9475	9745-0013	1MHz-1GHz	Mar. 23,2023	1 Year
Cable	Schwarzbeck	PLF-100	549489	9KHz-3GHz	Aug. 17,2023	1 Year
Spectrum Analyzer	Rohde&Schwarz	FSV40	6625-01-588-5515	9KHz-40GHz	Aug.17, 2023	1 Year
Horn Antenna	SCHWARZBEC K	9120D	9120D-1246	1GHz-18GHz	Aug. 17, 2023	1 Year
Power Amplifier	ZHINAN	ZN3380C	15002	1GHz-26.5GHz	Aug. 17, 2023	1 Year
Horn Antenna	SCHWARZBEC K	BBHA 9170	9170-1066	15GHz-40GHz	Jul. 19, 2023	1 Year
Amplifier	SCHWARZBEC K	BBV 9721	9721-205	18GHz-40GHz	Jul. 19, 2023	1 Year
Cable	H+S	CBL-26	N/A	1GHz-26.5GHz	Aug. 17,2023	1 Year
RF Cable	R&S	R204	R21X	1GHz-40GHz	Aug. 17,2023	1 Year
MXG Vector Signal Generator	Agilent	N5182A	MY49060455	-	Aug. 17,2023	1 Year
ESG Series Analog signal generator	Agilent	E4421B	GB40051240	-	Aug. 17,2023	1 Year

## 4. EFFECTIVE (ISOTROPIC) RADIATED POWER

### 4.1. Conducted Output Power

Measurement Procedure: FCC KDB 971168 D01 V03r01

The transmitter output was connected to a calibrated coaxial cable, attenuator and power meter, the other end of which was connected to a Base Station Simulator. The Base Station Simulator was set to force the EUT to its maximum power setting. The power output at the transmitter antenna port was determined by adding the value of the cable insertion loss to the power reading. The tests were performed at three frequencies (low channel, middle channel and high channel) and on the highest power levels, which can be setup on the transmitters.

### 4.2. Effective (Isotropic) Radiated Power

Measurement Procedure: FCC KDB 971168 D01 V03r01 ; C63.26 (2015).

Calculate power in dBm by the following formula:

ERP (dBm) = Conducted Power (dBm) + antenna gain (dBd)

EIRP(dBm) = Conducted Power (dBm) + antenna gain (dBi)

EIRP=ERP+2.15dB

#### Test Result:

- 1.For E-UTRA Band 2, please refer to Appendix Band 2: Section Appendix A.
2. For E-UTRA Band 4, please refer to Appendix Band 4: Section Appendix A.
- 3.For E-UTRA Band 5, please refer to Appendix Band 5: Section Appendix A.
- 4.For E-UTRA Band 12, please refer to Appendix Band12: Section Appendix A.
- 5.For E-UTRA Band 13, please refer to Appendix Band 13: Section Appendix A.
- 6.For E-UTRA Band 17, please refer to Appendix Band 17: Section Appendix A.
- 7.For E-UTRA Band 25, please refer to Appendix Band 25: Section Appendix A.
- 8.For E-UTRA Band 26, please refer to Appendix Band 26: Section Appendix A.
- 9.For E-UTRA Band 41, please refer to Appendix Band 41: Section Appendix A.
- 10.For E-UTRA Band 66, please refer to Appendix Band 66: Section Appendix A.
- 11.For E-UTRA Band 71, please refer to Appendix Band 71: Section Appendix A.

## 5. SPURIOUS EMISSION (Conducted and Radiated)

### 5.1. Measurement Result (Pre-measurement)

#### E-UTRA BANDS

#### BAND 5:

Bandwidth	UL Channel	Frequency	Modulation	RB Size	RB Offset	Judgement
1.4	20407	824.7	QPSK	6	LOW	Pass
1.4	20407	824.7	16QAM	6	LOW	Pass
1.4	20525	836.5	QPSK	6	LOW	Pass
1.4	20525	836.5	16QAM	6	LOW	Pass
1.4	20643	848.3	QPSK	6	LOW	Pass
1.4	20643	848.3	16QAM	6	LOW	Pass
3	20415	825.5	QPSK	15	LOW	Pass
3	20415	825.5	16QAM	15	LOW	Pass
3	20525	836.5	QPSK	15	LOW	Pass
3	20525	836.5	16QAM	15	LOW	Pass
3	20635	847.5	QPSK	15	LOW	Pass
3	20635	847.5	16QAM	15	LOW	Pass
5	20425	826.5	QPSK	25	LOW	Pass
5	20425	826.5	16QAM	25	LOW	Pass
5	20525	836.5	QPSK	25	LOW	Pass
5	20525	836.5	16QAM	25	LOW	Pass
5	20625	846.5	QPSK	25	LOW	Pass
5	20625	846.5	16QAM	25	LOW	Pass
10	20450	829	QPSK	50	LOW	Pass
10	20450	829	16QAM	50	LOW	Pass
10	20525	836.5	QPSK	50	LOW	Pass
10	20525	836.5	16QAM	50	LOW	Pass
10	20600	844	QPSK	50	LOW	Pass
10	20600	844	16QAM	50	LOW	Pass

#### BAND 7:

Bandwidth	UL Channel	Frequency	Modulation	RB Size	RB Offset	Judgement
5	20775	2502.5	QPSK	25	LOW	Pass
5	20775	2502.5	16QAM	25	LOW	Pass
5	21425	2567.5	QPSK	25	LOW	Pass
5	21425	2567.5	16QAM	25	LOW	Pass
5	21100	2535	QPSK	25	LOW	Pass
5	21100	2535	16QAM	25	LOW	Pass
10	20800	2505	QPSK	50	LOW	Pass
10	20800	2505	16QAM	50	LOW	Pass
10	21400	2565	QPSK	50	LOW	Pass
10	21400	2565	16QAM	50	LOW	Pass
10	21100	2535	QPSK	50	LOW	Pass
10	21100	2535	16QAM	50	LOW	Pass
15	20825	2507.5	QPSK	75	LOW	Pass
15	20825	2507.5	16QAM	75	LOW	Pass

Bandwidth	UL Channel	Frequency	Modulation	RB Size	RB Offset	Judgement
15	21375	2562.5	QPSK	75	LOW	Pass
15	21375	2562.5	16QAM	75	LOW	Pass
15	21100	2535	QPSK	75	LOW	Pass
15	21100	2535	16QAM	75	LOW	Pass
20	20850	2510	QPSK	100	LOW	Pass
20	20850	2510	16QAM	100	LOW	Pass
20	21350	2560	QPSK	100	LOW	Pass
20	21350	2560	16QAM	100	LOW	Pass
20	21100	2535	QPSK	100	LOW	Pass
20	21100	2535	16QAM	100	LOW	Pass

**Band 41:**

Bandwidth	UL Channel	Frequency	Modulation	RB Size	RB Offset	Judgement
5	39675	2498.5	QPSK	1RB#0	LOW	Pass
5	39675	2498.5	16QAM	1RB#0	LOW	Pass
5	40620	2593	QPSK	1RB#0	LOW	Pass
5	40620	2593	16QAM	1RB#0	LOW	Pass
5	41565	2687.5	QPSK	1RB#0	LOW	Pass
5	41565	2687.5	QPSK	1RB#0	LOW	Pass
10	39700	2501	QPSK	1RB#0	LOW	Pass
10	39700	2501	16QAM	1RB#0	LOW	Pass
10	40620	2593	QPSK	1RB#0	LOW	Pass
10	40620	2593	16QAM	1RB#0	LOW	Pass
10	41540	2685	QPSK	1RB#0	LOW	Pass
10	41540	2685	16QAM	1RB#0	LOW	Pass
15	39725	2503.5	QPSK	1RB#0	LOW	Pass
15	39725	2503.5	16QAM	1RB#0	LOW	Pass
15	40620	2593	QPSK	1RB#0	LOW	Pass
15	40620	2593	16QAM	1RB#0	LOW	Pass
15	41515	2682.5	QPSK	1RB#0	LOW	Pass
15	41515	2682.5	16QAM	1RB#0	LOW	Pass
20	39750	2506	QPSK	1RB#0	LOW	Pass
20	39750	2506	16QAM	1RB#0	LOW	Pass
20	40620	2593	QPSK	1RB#0	LOW	Pass
20	40620	2593	16QAM	1RB#0	LOW	Pass
20	41490	2680	QPSK	1RB#0	LOW	Pass
20	41490	2680	16QAM	1RB#0	LOW	Pass

**Note:** Radiated spurious emission, All RB configurations combined with QPSK and 16QAM all pretested and recorded the worst case.

**Test Plot(s)**  
**Conducted method**

**Test limit:**

The spurious (unwanted) emission limits specified in the individual FCC rule parts applicable to licensed digital transmitters (typically referred to under the heading 'emission limits') normally apply to any and all emissions that are present outside of the authorized frequency band/block and apply to emissions in both the out-of-band and spurious domains. In some rule parts, the unwanted emission limits are specified by an emission mask that defines the applicable limit as a function of the frequency range relative to the authorized frequency block.

Typically, unwanted emissions are required by the licensed rule parts to be attenuated below the transmitter power by a factor of at least  $X + 10\log(P)$  dB, where P represents the transmitter power expressed in watts and X is a specified scalar value (e.g., 43). This specification can be interpreted in one of two equivalent ways. First, the required attenuation can be construed to be relative to the mean carrier power, with the resultant of the equation  $X + 10\log(P)$  being expressed in dBc (dB relative to the maximum carrier power). Alternatively, the specification can be interpreted as an absolute limit when the specified attenuation is actually subtracted from the maximum permissible transmitter power [i.e.,  $10\log(P) - \{X + 10\log(P)\}$ ], resulting in an absolute level of -X dBW [or (-X + 30) dBm]. See section 4.

**Test procedure:**

The RF output of the transceiver was connected to a spectrum analyzer and simulator through appropriate attenuation. The resolution bandwidth of the spectrum analyzer was set at 100 kHz below 1 GHz and 1 MHz above 1 GHz. Sufficient scans were taken to show any out of band emissions up to 10th harmonics.

**Conducted Emission Test-Up:**

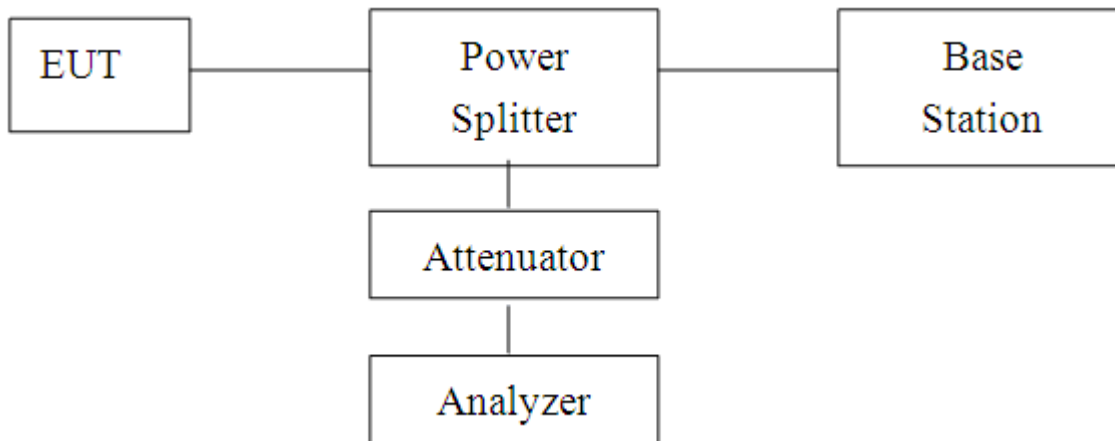

**Test data:**

1. For E-UTRA Band 2, please refer to Appendix Band 2: Section Appendix E.
2. For E-UTRA Band 4, please refer to Appendix Band 4: Section Appendix E.
3. For E-UTRA Band 5, please refer to Appendix Band 5: Section Appendix E.
4. For E-UTRA Band 12, please refer to Appendix Band 12: Section Appendix E.
5. For E-UTRA Band 13, please refer to Appendix Band 13: Section Appendix E.
6. For E-UTRA Band 17, please refer to Appendix Band 17: Section Appendix E.
7. For E-UTRA Band 25, please refer to Appendix Band 25: Section Appendix E.
8. For E-UTRA Band 26, please refer to Appendix Band 26: Section Appendix E.
9. For E-UTRA Band 41, please refer to Appendix Band 41: Section Appendix E.
10. For E-UTRA Band 66, please refer to Appendix Band 66: Section Appendix E.
11. For E-UTRA Band 71, please refer to Appendix Band 71: Section Appendix E.

## Radiated method

### Test limit:

The spurious (unwanted) emission limits specified in the individual FCC rule parts applicable to licensed digital transmitters (typically referred to under the heading 'emission limits') normally apply to any and all emissions that are present outside of the authorized frequency band/block and apply to emissions in both the out-of-band and spurious domains. In some rule parts, the unwanted emission limits are specified by an emission mask that defines the applicable limit as a function of the frequency range relative to the authorized frequency block.

Typically, unwanted emissions are required by the licensed rule parts to be attenuated below the transmitter power by a factor of at least  $X + 10\log(P)$  dB, where  $P$  represents the transmitter power expressed in watts and  $X$  is a specified scalar value (e.g., 43). This specification can be interpreted in one of two equivalent ways. First, the required attenuation can be construed to be relative to the mean carrier power, with the resultant of the equation  $X + 10\log(P)$  being expressed in dBc (dB relative to the maximum carrier power). Alternatively, the specification can be interpreted as an absolute limit when the specified attenuation is actually subtracted from the maximum permissible transmitter power [i.e.,  $10\log(P) - \{X + 10\log(P)\}$ ], resulting in an absolute level of  $-X$  dBW [or  $(-X + 30)$  dBm]. See section 4.

### Test procedure:

The radiated emission tests were performed in the 3m Semi- Anechoic Chamber test site. The resolution bandwidth of the spectrum analyzer was set at 100 kHz below 1 GHz and 1 MHz above 1 GHz. Sufficient scans were taken to show any out of band emissions up to 10th harmonics.

### Test setup:

#### (A) Radiated Emission Test-Up Frequency 30MHz~1GHz

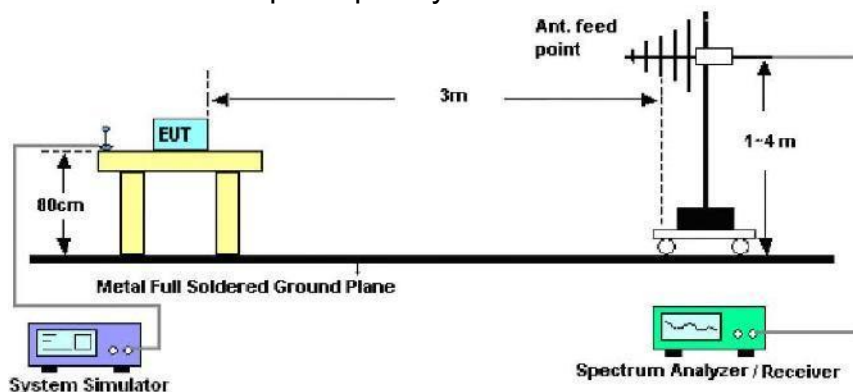

#### (B) Radiated Emission Test-Up Frequency Above 1GHz

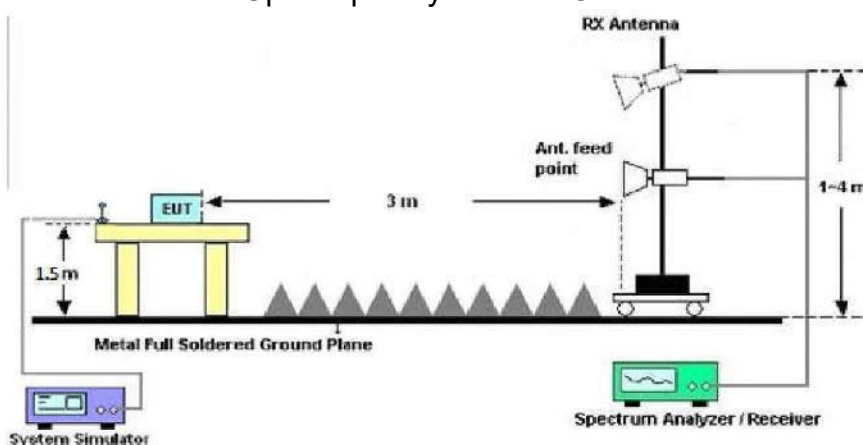

### Note:

1, Below 30MHz no Spurious found.

2, UE is positioned at 3 axis at the pre-scan stage, and only the measurement of the worst case (bandwidth: 20MHz / Full RB / QPSK) is reported in this part.



## List of final test modes:

**E-UTRA BANDS**

This is the worst pattern data

**E-UTRA Band 2:**

Mode	Bandwidth	UL Channel	Frequency	Modulation	Judgement
1	1.4	19774	1767.4	QPSK	Pass

**E-UTRA Band 4:**

Mode	Bandwidth	UL Channel	Frequency	Modulation	Judgement
1	1.4	20175	1732.5	QPSK	Pass

**E-UTRA Band 5:**

Mode	Bandwidth	UL Channel	Frequency	Modulation	Judgement
1	1.4	20525	836.5	QPSK	Pass

**E-UTRA Band 12:**

Mode	Bandwidth	UL Channel	Frequency	Modulation	Judgement
1	1.4	23095	707.5	QPSK	Pass

**E-UTRA Band 13:**

Mode	Bandwidth	UL Channel	Frequency	Modulation	Judgement
1	5	23230	782	QPSK	Pass

**E-UTRA Band 17:**

Mode	Bandwidth	UL Channel	Frequency	Modulation	Judgement
1	5	20525	836.5	QPSK	Pass

**E-UTRA Band 25:**

Mode	Bandwidth	UL Channel	Frequency	Modulation	Judgement
1	1.4	23790	710	QPSK	Pass

**E-UTRA Band 26:**

Mode	Bandwidth	UL Channel	Frequency	Modulation	Judgement
1	1.4	26697	814.7	QPSK	Pass

**E-UTRA Band 41:**

Mode	Bandwidth	UL Channel	Frequency	Modulation	Judgement
1	5	40620	2593	QPSK	Pass

**E-UTRA Band 66:**

Mode	Bandwidth	UL Channel	Frequency	Modulation	Judgement
1	1.4	132197	1732.5	QPSK	Pass

**E-UTRA Band 71:**

Mode	Bandwidth	UL Channel	Frequency	Modulation	Judgement
1	5	133297	680.5	QPSK	Pass

Test record:

**E-UTRA BANDS Radiated spurious emissions Spot-check :**  
**E-UTRA band 2 \_1.4MHz bandwidth \_Middle Channel**

Frequency(MHz)	Reading level(dBm)	Factor(dB)	Level (dBm)	Limit (dBm)	Margin (dBm)	Polarity
3760.00	-48.19	-1.05	-49.24	-13.00	36.24	Horizontal
5640.00	-43.81	7.15	-36.66	-13.00	23.66	Horizontal
7520.00	-52.82	11.45	-41.37	-13.00	28.37	Horizontal
3760.00	-49.99	1.53	-48.46	-13.00	35.46	Vertical
5640.00	-42.43	4.45	-37.99	-13.00	24.99	Vertical
7520.00	-53.59	9.96	-43.63	-13.00	30.63	Vertical

**E-UTRA band 4 \_1.4MHz bandwidth \_Middle Channel**

Frequency(MHz)	Reading level(dBm)	Factor(dB)	Level (dBm)	Limit (dBm)	Margin (dBm)	Polarity
3465.00	-48.18	-2.43	-50.61	-13.00	37.61	Horizontal
5197.50	-40.7	4.14	-36.56	-13.00	23.56	Horizontal
6930.20	-48.7	10.97	-37.73	-13.00	24.73	Horizontal
3465.00	-48.61	-2.18	-50.79	-13.00	37.79	Vertical
5197.50	-42.1	3.76	-38.34	-13.00	25.34	Vertical
6930.20	-47.95	9.52	-38.43	-13.00	25.43	Vertical

**E-UTRA band 5 \_1.4MHz bandwidth \_Middle Channel**

Frequency(MHz)	Reading level(dBm)	Factor(dB)	Level (dBm)	Limit (dBm)	Margin (dBm)	Polarity
1673.00	-47.7	-11.02	-58.72	-13	45.72	Horizontal
2509.50	-41.17	-6.13	-47.30	-13	34.30	Horizontal
3346.00	-48.92	-4.93	-53.85	-13	40.85	Horizontal
1673.00	-48.76	-11.02	-59.78	-13	46.78	Vertical
2509.50	-42.12	-6.13	-48.25	-13	35.25	Vertical
3346.00	-48.46	-4.93	-53.39	-13	40.39	Vertical

**E-UTRA band 12\_1.4MHz bandwidth\_Middle Channel**

Frequency(MHz)	Reading level(dBm)	Factor(dB)	Level (dBm)	Limit (dBm)	Margin (dBm)	Polarity
1415.00	-47.83	-12.84	-60.67	-13.00	47.67	Horizontal
2122.50	-41.04	-8.87	-49.91	-13.00	36.91	Horizontal
2830.00	-48.95	-6.03	-54.98	-13.00	41.98	Horizontal
1415.00	-49.17	-13.05	-62.22	-13.00	49.22	Vertical
2122.50	-42.06	-8.75	-50.81	-13.00	37.81	Vertical
2830.00	-48.65	-5.85	-54.50	-13.00	41.50	Vertical

**E-UTRA band 13\_5MHz bandwidth\_Middle Channel**

Frequency(MHz)	Reading level(dBm)	Factor(dB)	Level (dBm)	Limit (dBm)	Margin (dBm)	Polarity
1564.00	-47.54	-12.00	-59.54	-13.00	46.54	Horizontal
2346.00	-40.34	-7.62	-47.96	-13.00	34.96	Horizontal
3128.00	-48.95	-5.41	-54.36	-13.00	41.36	Horizontal
1564.00	-48.53	-12.14	-60.67	-13.00	47.67	Vertical
2346.00	-42.19	-7.39	-49.58	-13.00	36.58	Vertical
3128.00	-48.55	-5.34	-53.89	-13.00	40.89	Vertical

**E-UTRA band 17\_5MHz bandwidth\_Middle Channel**

Frequency(MHz)	Reading level(dBm)	Factor(dB)	Level (dBm)	Limit (dBm)	Margin (dBm)	Polarity
1420.00	-47.64	-12.81	-60.45	-13.00	47.45	Horizontal
2130.00	-40.75	-8.83	-49.58	-13.00	36.58	Horizontal
2840.00	-48.33	-6.01	-54.34	-13.00	41.34	Horizontal
1420.00	-48.52	-13.02	-61.54	-13.00	48.54	Vertical
2130.00	-42.08	-8.71	-50.79	-13.00	37.79	Vertical
2840.00	-48.45	-5.83	-54.28	-13.00	41.28	Vertical

**E-UTRA band 25\_1.4MHz bandwidth\_Middle Channel**

Frequency(MHz)	Reading level(dBm)	Factor(dB)	Level (dBm)	Limit (dBm)	Margin (dBm)	Polarity
3765.00	-47.58	-1.04	-48.62	-13.00	35.62	Horizontal
5647.50	-41.05	7.16	-33.89	-13.00	20.89	Horizontal
7530.00	-48.8	11.44	-37.36	-13.00	24.36	Horizontal
3765.00	-48.95	-1.53	-50.48	-13.00	37.48	Vertical
5647.50	-41.69	4.48	-37.21	-13.00	24.21	Vertical
7530.00	-47.93	10.03	-37.90	-13.00	24.90	Vertical

**E-UTRA band 26\_1.4MHz bandwidth\_Low Channel**

Frequency(MHz)	Reading level(dBm)	Factor(dB)	Level (dBm)	Limit (dBm)	Margin (dBm)	Polarity
1629.40	-48.48	-11.45	-59.93	-13.00	46.93	Horizontal
2444.10	-40.7	-6.78	-47.48	-13.00	34.48	Horizontal
3258.80	-48.61	-2.12	-50.73	-13.00	37.73	Horizontal
1629.40	-49.42	-11.54	-60.96	-13.00	47.96	Vertical
2444.10	-41.73	-6.49	-48.22	-13.00	35.22	Vertical
3258.80	-47.88	-1.44	-49.32	-13.00	36.32	Vertical

**E-UTRA band 41\_5MHz bandwidth\_ Middle Channel**

Frequency(MHz)	Reading level(dBm)	Factor(dB)	Level (dBm)	Limit (dBm)	Margin (dBm)	Polarity
5186.00	-50.52	4.20	-46.32	-25	21.32	Horizontal
7779.00	-49.69	11.35	-38.34	-25	13.34	Horizontal
10372.00	-52.74	18.37	-34.37	-25	9.37	Horizontal
5186.00	-50.53	3.72	-46.81	-25	21.81	Vertical
7779.00	-51.49	10.84	-40.65	-25	15.65	Vertical
10372.00	-52.45	17.09	-35.36	-25	10.36	Vertical

**E-UTRA band 66\_1.4MHz bandwidth\_ Middle Channel**

Frequency(MHz)	Reading level(dBm)	Factor(dB)	Level (dBm)	Limit (dBm)	Margin (dBm)	Polarity
3465.00	-49.56	-2.3	-51.86	-13	38.86	Horizontal
5197.50	-50.7	3.87	-46.83	-13	33.83	Horizontal
6930.00	-53.59	11.03	-42.56	-13	29.56	Horizontal
3465.00	-50.31	-2.43	-52.74	-13	39.74	Vertical
5197.50	-52.43	3.45	-48.98	-13	35.98	Vertical
6930.00	-52.28	9.58	-42.7	-13	29.7	Vertical

**E-UTRA band 71\_5MHz bandwidth\_ Middle Channel**

Frequency(MHz)	Reading level(dBm)	Factor(dB)	Level (dBm)	Limit (dBm)	Margin (dBm)	Polarity
1361.00	-49.66	-13.14	-62.8	-13.00	49.8	Horizontal
2041.50	-50.13	-7.31	-57.44	-13.00	44.44	Horizontal
2722.00	-52.77	-6.26	-59.03	-13.00	46.03	Horizontal
1361.00	-50.75	-13.38	-64.13	-13.00	51.13	Vertical
2041.50	-51.95	-7.06	-59.01	-13.00	46.01	Vertical
2722.00	-52.2	-5.11	-57.31	-13.00	44.31	Vertical

Note:1. The emission levels of below 1 GHz are lower than the limit 10dB, so not show in test report.  
2. Level= Reading level+ Factor; Margin= Limit- Level.

## 6. Occupied Bandwidth and Emission Bandwidth

Test limit:

The occupied bandwidth (OBW), that is the frequency bandwidth such that, below its lower and above its upper frequency limits, the mean powers radiated are each equal to 0.5 percent of the total mean power radiated by a given emission, shall be measured when modulated by an input signal such that its amplitude and symbol rate represent the maximum rated conditions under which the equipment will be operated. The signal shall be applied through any filter networks, pseudo-random generators or other devices required in normal service. Additionally, the occupied bandwidth shall be shown for operation with any devices used for modifying the spectrum when such devices are optional at the discretion of the user. [i2.1049(h)]

Many of the individual rule parts specify a relative OBW in lieu of the 99% OBW. In such cases, the OBW is defined as the width of the signal between two points, one below the carrier center frequency and one above the carrier center frequency, outside of which all emissions are attenuated by at least X dB below the transmitter power, where the value of X is typically specified as 26.

The relative OBW must be measured and reported when it is specified in the applicable rule part; otherwise, the 99% OBW shall be measured and reported. The test report shall specify which OBW is reported.

A spectrum/signal analyzer or other instrument providing a spectral display is recommended for these measurements and the video bandwidth shall be set to a value at least three times greater than the IF/resolution bandwidth to avoid any amplitude smoothing. Video filtering shall not be used during occupied bandwidth tests.

The OBW shall be measured for all operating conditions that will affect the bandwidth results (e.g. variable modulations, coding, or channel bandwidth settings). See section 4.

Test procedure:

Occupied bandwidth – relative measurement procedure

The reference value is the highest level of the spectral envelope of the modulated signal.

a) The spectrum analyzer center frequency is set to the nominal EUT channel center frequency. The span range for the spectrum analyzer shall be between two and five times the anticipated OBW.

b) The nominal resolution bandwidth (RBW) shall be in the range of 1 to 5 % of the anticipated OBW, and the VBW shall be at least 3 times the RBW.

c) Set the reference level of the instrument as required to prevent the signal from exceeding the maximum input mixer level for linear operation. In general, the peak of the spectral envelope must be at least  $10\log(\text{OBW} / \text{RBW})$  below the reference level.

d) NOTE—Steps a) through c) may require iteration to adjust within the specified tolerances.

e) The dynamic range of the spectrum analyzer at the selected RBW shall be at least 10 dB below the target “-X dB down” requirement (i.e., if the requirement calls for measuring the -26 dB OBW, the spectrum analyzer noise floor at the selected RBW shall be at least 36 dB below the reference value).

f) Set the detection mode to peak, and the trace mode to max hold.

g) Determine the reference value: Set the EUT to transmit a modulated signal. Allow the trace to stabilize. Set the spectrum analyzer marker to the highest level of the displayed

trace (this is the reference value).

h) Determine the “-X dB down amplitude” as equal to (Reference Value – X). Alternatively, this calculation can be performed by the analyzer by using the marker-delta function.

i) Place two markers, one at the lowest and the other at the highest frequency of the envelope of the spectral display such that each marker is at or slightly below the “-X dB down amplitude” determined in step g). If a marker is below this “-X dB down amplitude” value it shall be placed as close as possible to this value. The OBW is the positive frequency difference between the two markers.

j) The occupied bandwidth shall be reported by providing plot(s) of the measuring instrument display. The frequency and amplitude axes and scale shall be clearly labeled. Tabular data may be reported in addition to the plot(s).

Occupied bandwidth – power bandwidth (99%) measurement procedure

The following procedure shall be used for measuring (99 %) power bandwidth

a) The spectrum analyzer center frequency is set to the nominal EUT channel center frequency. The frequency span for the spectrum analyzer shall be set wide enough to capture all modulation products including the emission skirts (i.e., two to five times the OBW).

b) The nominal IF filter bandwidth (3 dB RBW) shall be in the range of 1 to 5 % of the anticipated OBW, and the VBW shall be at least 3 times the RBW.

c) Set the reference level of the instrument as required to keep the signal from exceeding the maximum input mixer level for linear operation. In general, the peak of the spectral envelope must be at least  $10\log(\text{OBW} / \text{RBW})$  below the reference level.

d) NOTE—Steps a) through c) may require iteration to adjust within the specified tolerances.

e) Set the detection mode to peak, and the trace mode to max hold..

f) Use the 99 % power bandwidth function of the spectrum analyzer (if available) and report the measured bandwidth.

g) If the instrument does not have a 99 % power bandwidth function, the trace data points are to be recovered and directly summed in linear power terms. The recovered amplitude data points, beginning at the lowest frequency, are placed in a running sum until 0.5 % of the total is reached; that frequency is recorded as the lower frequency. The process is repeated until 99.5 % of the total is reached; that frequency is recorded as the upper frequency. The 99 % power bandwidth is the difference between these two frequencies.

h) The OBW shall be reported by providing plot(s) of the measuring instrument display. The frequency and amplitude axes and scale shall be clearly labeled. Tabular data may be reported in addition to the plot(s).

Test setup:

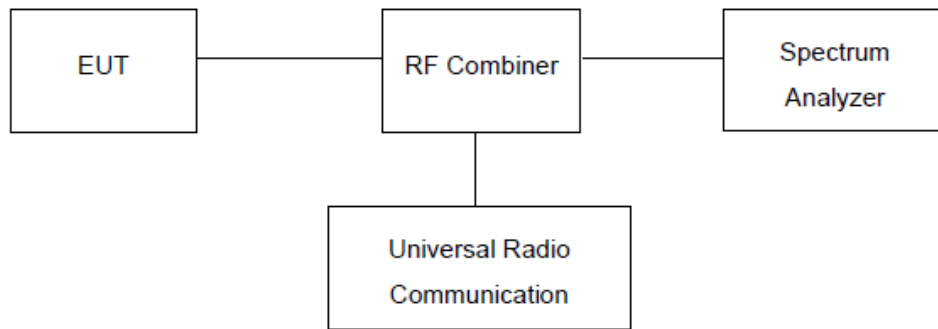

**Measurement Result:**

1. For E-UTRA Band 2, please refer to Appendix Band 2: Section Appendix C.
2. For E-UTRA Band 4, please refer to Appendix Band 4: Section Appendix C.
3. For E-UTRA Band 5, please refer to Appendix Band 5: Section Appendix C.
4. For E-UTRA Band 12, please refer to Appendix Band 12: Section Appendix C.
5. For E-UTRA Band 13, please refer to Appendix Band 13: Section Appendix C.
6. For E-UTRA Band 17, please refer to Appendix Band 17: Section Appendix C.
7. For E-UTRA Band 25, please refer to Appendix Band 25: Section Appendix C.
8. For E-UTRA Band 26, please refer to Appendix Band 26: Section Appendix C.
9. For E-UTRA Band 41, please refer to Appendix Band 41: Section Appendix C.
10. For E-UTRA Band 66, please refer to Appendix Band 66: Section Appendix C.
11. For E-UTRA Band 71, please refer to Appendix Band 71: Section Appendix C.



## 7. Band Edge

### Test Limit:

The radio frequency voltage or powers generated within the equipment and appearing on a spurious frequency shall be checked at the equipment output terminals when properly loaded with a suitable artificial antenna. Curves or equivalent data shall show the magnitude of each harmonic and other spurious emission that can be detected when the equipment is operated under the conditions specified in §2.1049 as appropriate. The magnitude of spurious emissions which are attenuated more than 20 dB below the permissible value need not be specified. See section 4.

### Test procedure:

The RF output of the transmitter was connected to the input of the spectrum analyzer through sufficient attenuation.

### Test setup:

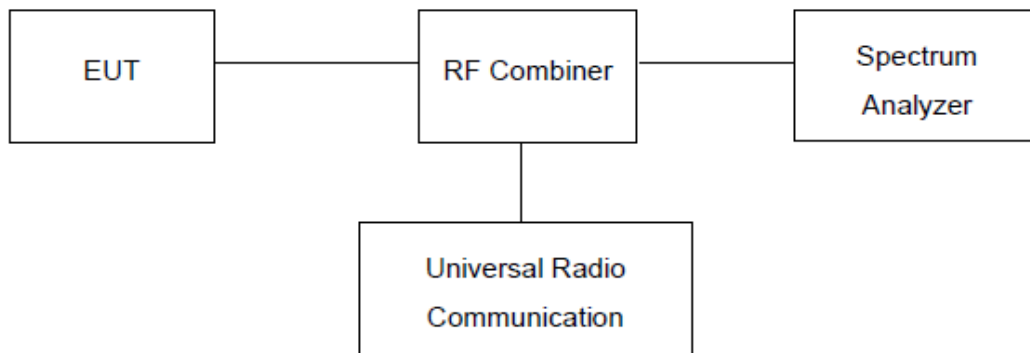

## Measurement Result

- 1.For E-UTRA Band 2, please refer to Appendix Band 2: Section Appendix D.
2. For E-UTRA Band 4, please refer to Appendix Band 4: Section Appendix D.
- 3.For E-UTRA Band 5, please refer to Appendix Band 5: Section Appendix D.
- 4.For E-UTRA Band 12, please refer to Appendix Band12: Section Appendix D.
- 5.For E-UTRA Band 13, please refer to Appendix Band 13: Section Appendix D.
- 6.For E-UTRA Band 17, please refer to Appendix Band 17: Section Appendix D.
- 7.For E-UTRA Band 25, please refer to Appendix Band 25: Section Appendix D.
- 8.For E-UTRA Band 26, please refer to Appendix Band 26: Section Appendix D.
- 9.For E-UTRA Band 41, please refer to Appendix Band 41: Section Appendix D.
- 10.For E-UTRA Band 66, please refer to Appendix Band 66: Section Appendix D.
- 11.For E-UTRA Band 71, please refer to Appendix Band 71: Section Appendix D.

## 8. Frequency Stability

### Test limit:

The frequency stability of the transmitter shall be measured while varying the ambient temperatures and supply voltages over the ranges specified in §2.1055. The specific frequency stability limits are provided in the relevant rules section(s). see section 4.

### Test procedure:

Frequency Stability vs. Temperature: The equipment under test was connected to an external DC power supply and the RF output was connected to communication test set via feed-through attenuators. The EUT was placed inside the temperature chamber. The DC leads and RF output cable exited the chamber through an opening made for the purpose.

### Test setup:

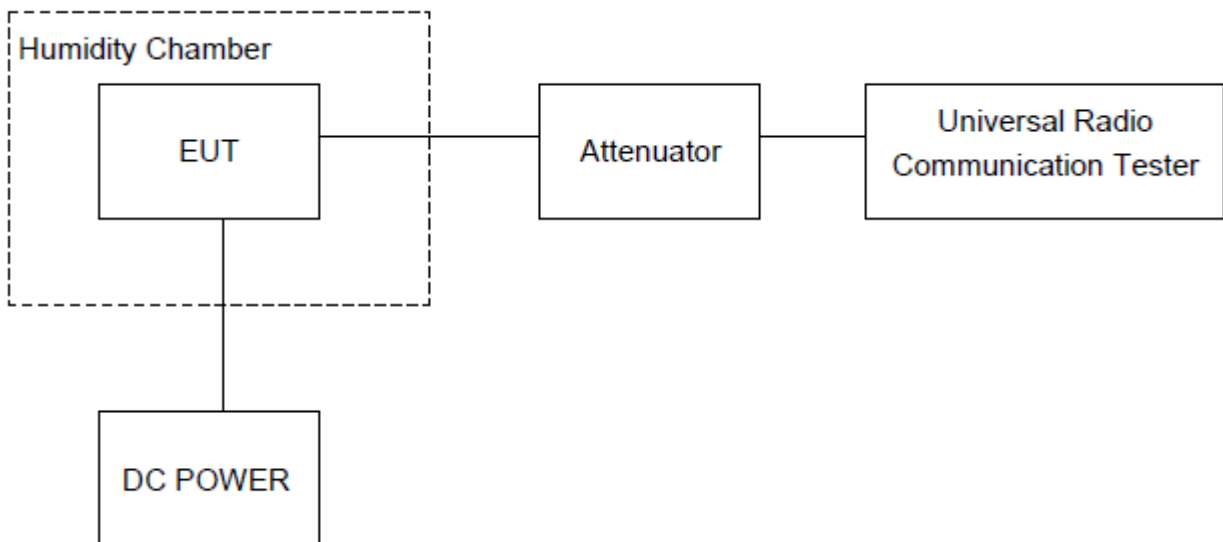

## **8.1. Measurement Result (Worst)**

- 1.For E-UTRA Band 2, please refer to Appendix Band 2: Section Appendix F.
2. For E-UTRA Band 4, please refer to Appendix Band 4: Section Appendix F.
- 3.For E-UTRA Band 5, please refer to Appendix Band 5: Section Appendix F.
- 4.For E-UTRA Band 12, please refer to Appendix Band12: Section Appendix F.
- 5.For E-UTRA Band 13, please refer to Appendix Band 13: Section Appendix F.
- 6.For E-UTRA Band 17, please refer to Appendix Band 17: Section Appendix F.
- 7.For E-UTRA Band 25, please refer to Appendix Band 25: Section Appendix F.
- 8.For E-UTRA Band 26, please refer to Appendix Band 26: Section Appendix F.
- 9.For E-UTRA Band 41, please refer to Appendix Band 41: Section Appendix F.
- 10.For E-UTRA Band 66, please refer to Appendix Band 66: Section Appendix F.
- 11.For E-UTRA Band 71, please refer to Appendix Band 71: Section Appendix F.

## **15 APPENDIX I -- TEST SETUP PHOTOGRAPH**

Refer to "Test Setup Photos".

## 16 APPENDIX II -- EUT PHOTOGRAPH

Refer to " External Photos" and "Internal Photos".

**\*\*\*\*\*THE END REPORT\*\*\*\*\***