

# FCC TEST REPORT

## FCC ID: 2BCQA-G65

Product	:	Phone
Model Name	:	G65
Brand	:	N/A
Report No.	:	NCT24002161E-FC06
<b>Prepared for</b>		
Clover Industrial Co.,Ltd		
Building 4, Hengchangrong High-tech Industrial Park, Shangnan East Road, Hongtian,Huangpu Community, Xinqiao Street, Baoan District, Shenzhen		
<b>Prepared by</b>		
Shenzhen NCT Testing Technology Co., Ltd.		
A101&2F B2, Fuqiao 6th Area, Xintian Community, Fuhai Street, Baoan District, Shenzhen, People's Republic of China		
TEL: 400-8868-419		
FAX: 86-755-27790922		

## 1 Test Result Certification

Applicant's name : Clover Industrial Co.,Ltd  
Address : Building 4, Hengchangrong High-tech Industrial Park, Shangnan  
East Road, Hongtian, Huangpu Community, Xinqiao Street,  
Baoan District, Shenzhen  
Manufacture's name : Clover Industrial Co.,Ltd  
Address : Building 4, Hengchangrong High-tech Industrial Park, Shangnan  
EastRoad, Hongtian, Huangpu Community, Xingiao Street,  
Baoan District, shenzhen  
Product name : Phone  
Model name : G65  
Standards : 47 CFR FCC Part 22 Subpart H, 47 CFR FCC Part 24 Subpart E,  
ANSI C63.26-2015,  
KDB 971168 D01 Power Meas License Digital Systems v03r01  
Test Date : Nov. 23, 2023 to Dec. 30, 2023  
Date of Issue : Dec. 30, 2023  
Test Result : Pass

This device described above has been tested by NCT, and the test results show that the equipment under test (EUT) is in compliance with the FCC requirements. And it is applicable only to the tested sample identified in the report.

This report shall not be reproduced except in full, without the written approval of NCT, this document may be altered or revised by NCT, personal only, and shall be noted in the revision of the document.

Test Engineer:



Keven Wu / Engineer

Technical Manager:



Henry Wang / Manager

**TABLE OF CONTENTS**

**1 Test Result Certification ..... 2**

**1. General Description Of Eut ..... 4**

**2. Facilities And Accreditations..... 6**

    2.1. TEST FACILITY .....6

    2.2. DESCRIPTION OF TEST CHANNELS AND TEST MODES .....7

    2.3. EQUIPMENT MODIFICATIONS .....8

**3. Summary Of Test Requirements And Results..... 9**

**4. Measurement Instruments ..... 10**

**5. Effective (Isotropic) Radiated Power and Conducted Output Power 12**

    5.1. CONDUCTED OUTPUT POWER .....12

    5.2. EFFECTIVE (ISOTROPIC) RADIATED POWER .....12

**6. Spurious Emission (Conducted and Radiated) ..... 16**

    6.1. MEASUREMENT RESULT (PRE-MEASUREMENT).....16

**7. Occupied Bandwidth and Emission Bandwidth ..... 32**

**8. Band Edge..... 37**

**9. Peak-to-Average Ratio(PAR)..... 41**

**10. Frequency Stability..... 45**

    10.1. MEASUREMENT RESULT (WORST).....46

**15 APPENDIX I -- TEST SETUP PHOTOGRAPH ..... 48**

**16 APPENDIX II -- EUT PHOTOGRAPH..... 49**

## 1. General Description Of Eut

<b>Equipment Type:</b>	POS SYSTEM
<b>Hardware version:</b>	K20-V2.0k
<b>Software version:</b>	N/A
<b>Frequency Bands:</b>	WCDMA: <input checked="" type="checkbox"/> WCDMA Band II <input checked="" type="checkbox"/> WCDMA Band V
<b>Antenna Type:</b>	FPC Antenna
<b>Antenna gain:</b>	WCDMA Band II : 0.94dBi WCDMA Band V : -4.76dBi
<b>Type of Modulation:</b>	<input checked="" type="checkbox"/> RMC(QPSK) <input checked="" type="checkbox"/> HSUPA(QPSK) <input checked="" type="checkbox"/> HSDPA(QPSK,16QAM)
<b>Adapter Information:</b>	Battery Model: 456797 3.8V by Rechargeable Li-ion Battery, 4000mAh
<b>Max power:</b>	See Table 2.1
<b>Extreme Vol. Limits:</b>	DC 3.4V to 4.2V (Normal: DC 3.8V)
<b>Test sample No.</b>	NCT24002161E-1/2,NCT24002161E-2/2.

**Table 2.1 The Basic Technical Specification for Working BAND(S).**

OPERATION BAND(S)	Power Class	Mod.	Max Peak Power (dBm)
WCDMA BAND II	Class 3	QPSK	23.14
WCDMA Band V	Class 3	QPSK	15.19

## 2. Facilities And Accreditations

### 2.1. Test Facility

#### Site Description

EMC Lab. : Accredited by CNAS, 2022-09-27

The certificate is valid until 2028.01.07

The Laboratory has been assessed and proved to be in compliance with CNAS-CL01:2006 (identical to ISO/IEC 17025:2017)

The Certificate Registration Number is L8251

Designation Number: CN1347

Test Firm Registration Number: 894804

Accredited by A2LA, June 14, 2023

The Certificate Registration Number is 6837.01

Accredited by Industry Canada, November 09, 2018

The Conformity Assessment Body Identifier is CN0150

Company Number: 30806

Name of Firm : Shenzhen NCT Testing Technology Co., Ltd.

Site Location : A101&2F B2, Fuqiao 6th Area, Xintian Community, Fuhai Street, Baoan District, Shenzhen, People's Republic of China

## 2.2. Description Of Test Channels And Test Modes

### Test channels:

WCDMA BAND II			
Test Channel	BW(MHz)	UL Channel	Frequency(MHz)
Low Range	5	9262	1852.4
Mid Range	5	9400	1880
High Range	5	9538	1907.6

WCDMA BAND V			
Test Channel	BW(MHz)	UL Channel	Frequency(MHz)
Low Range	5	4132	826.4
Mid Range	5	4182	836.4
High Range	5	4233	846.6

Note 1: The worst condition was recorded in the test report if no other modes test data.

## **2.3. Equipment Modifications**

Not available for this EUT intended for grant.



### 3. Summary Of Test Requirements And Results

#### WCDMA Band V:

Test Item	FCC Rule No.	Requirements	Judgement
Effective (Isotropic) Radiated Power	§2.1046, §2.913(a)	EIRP $\leq$ 7W(38.5dBm)	Pass
Occupied Bandwidth	§2.1049	OBW: No limit.	Pass
Emission Bandwidth	22.917(b)	EBW: No limit.	Pass
Band Edges Compliance	§2.1051 §22.917(a)	$\leq$ -13 dBm/1%*EBW, in 1 MHz bands immediately outside and adjacent to the frequency block.	Pass
Spurious Emission at Antenna Terminals	§2.1051, §22.917	FCC: $\leq$ -13 dBm/100 kHz, from 9 kHz to 10th harmonics but outside authorized operating frequency ranges.	Pass
Field Strength of Spurious Radiation	§2.1053, §22.917	FCC: $\leq$ -13 dBm/100 kHz.	Pass
Frequency Stability	§2.1055, §22.355	the fundamental emissions stay within the authorized bands of operation. (2.5ppm)	Pass

#### WCDMA Band II:

Test Item	FCC Rule No.	Requirements	Judgement
Effective (Isotropic) Radiated Power	§2.1046, §24.232(c)	EIRP $\leq$ 2W(33dBm)	Pass
Bandwidth	§2.1049	OBW: No limit. EBW: No limit.	Pass
Band Edges	§2.1051, §24.238	$\leq$ -13 dBm/1%*EBW, in 1 MHz bands immediately outside and adjacent to the frequency block.	Pass
Spurious Emission at Antenna Terminals	§2.1051, §24.238	FCC: $\leq$ -13 dBm/100 kHz, from 9 kHz to 10th harmonics but outside authorized operating frequency ranges.	Pass
Field Strength of Spurious Radiation	§2.1053, §24.238(a)	-13dBm/1MHz	Pass
Frequency Stability	§2.1055, §24.235	the fundamental emission stays within the authorized frequency block. $\leq$ ±2.5ppm.	Pass
Peak to average ratio	§2.1046 §24.232	$\leq$ 13dB	Pass

## 4. Measurement Instruments

### RF Conducted Test

Name of Equipment	Manufacturer	Model	Serial No.	Characteristics	Last Calibration	Calibration Interval
MXG Signal Analyzer	Agilent	N9020A	SER MY5111038	10Hz-30GHz	Aug.17, 2023	1 Year
Coaxial Cable	CDS	79254	46107086	10Hz-30GHz	Aug.17, 2023	1 Year
Power Meter	Anritsu	ML2495A	0949003	300MHz-40GHz	Aug.17, 2023	1 Year
Power Sensor	Anritsu	MA2411B	0917017	300MHz-40GHz	Aug.17, 2023	1 Year
Signal Analyzer 40GHZ	Rohde&Schwarz	FSV40	101456	10Hz-40GHz	Aug.17, 2023	1 Year
Wireless Communication Tester	Rohde&Schwarz	CMW500	134930	/	Aug.17, 2023	1 year

Remark: The temporary antenna connector is soldered on the PCB board in order to perform conducted tests and this temporary antenna connector is listed in the equipment list.

Name of Equipment	Manufacturer	Model	Serial No.	Characteristics	Last Calibration	Calibration Interval
EMI Test Receiver	Rohde&Schwarz	ESC17	101671	9KHz-7GHz	Aug. 17,2023	1 Year
Loop Antenna	Schwarzbeck	FMZB 1519B	192	9 KHz -30MHz	Aug. 17,2023	1 Year
Bilog Antenna	SCHWARZBECK	VULB9160	9160-3355	25MHz-2GHz	Aug. 17,2023	1 Year
Preamplifier (low frequency)	SCHWARZBECK	BBV 9475	9745-0013	1MHz-1GHz	Mar. 23,2023	1 Year
Cable	Schwarzbeck	PLF-100	549489	9KHz-3GHz	Aug. 17,2023	1 Year
Spectrum Analyzer	Rohde&Schwarz	FSV40	6625-01-588-5515	9KHz-40GHz	Aug.17, 2023	1 Year
Horn Antenna	SCHWARZBECK	9120D	9120D-1246	1GHz-18GHz	Aug. 17, 2023	1 Year
Power Amplifier	ZHINAN	ZN3380C	15002	1GHz-26.5GHz	Aug. 17, 2023	1 Year
Horn Antenna	SCHWARZBECK	BBHA 9170	9170-1066	15GHz-40GHz	Jul. 19, 2023	1 Year

Amplifier	SCHWARZBECK	BBV 9721	9721-205	18GHz-40GHz	Jul. 19, 2023	1 Year
Cable	H+S	CBL-26	N/A	1GHz-26.5GHz	Aug. 17,2023	1 Year
RF Cable	R&S	R204	R21X	1GHz-40GHz	Aug. 17,2023	1 Year
MXG Vector Signal Generator	Agilent	N5182A	MY49060455	-	Aug. 17,2023	1 Year
ESG Series Analog signal generator	Agilent	E4421B	GB40051240	-	Aug. 17,2023	1 Year

## **5. Effective (Isotropic) Radiated Power and Conducted Output Power**

### **5.1. Conducted Output Power**

Measurement Procedure: FCC KDB 971168 D01 V03r01

The transmitter output was connected to a calibrated coaxial cable, attenuator and power meter, the other end of which was connected to a Base Station Simulator. The Base Station Simulator was set to force the EUT to its maximum power setting. The power output at the transmitter antenna port was determined by adding the value of the cable insertion loss to the power reading. The tests were performed at three frequencies (low channel, middle channel and high channel) and on the highest power levels, which can be setup on the transmitters.

### **5.2. Effective (Isotropic) Radiated Power**

Measurement Procedure: FCC KDB 971168 D01 V03r01 ; C63.26 (2015).

Calculate power in dBm by the following formula:

ERP (dBm) = Conducted Power (dBm) + antenna gain (dBd)

EIRP(dBm) = Conducted Power (dBm) + antenna gain (dBi)

EIRP=ERP+2.15dB

**Test result:****WCDMA Band 2 and Band 5 RMC:**

Band	Channel	Conducted Power(dBm)	ERP/EIRP(dBm)	Limit(dBm)	Verdict
Band2	9262	21.86	22.80	33	PASS
Band2	9400	21.97	22.91	33	PASS
Band2	9538	22.20	<b>23.14</b>	33	PASS
Band5	4132	22.10	<b>15.19</b>	38.5	PASS
Band5	4182	21.97	15.06	38.5	PASS
Band5	4233	22.07	15.16	38.5	PASS

**WCDMA Band 2 and Band 5 HSDPA :**

Band	Channel	SubTest	Conducted Power(dBm)	ERP/EIRP(dBm)	Limit(dBm)	Verdict
Band2	9262	1	20.89	21.83	33	PASS
Band2	9262	2	20.38	21.32	33	PASS
Band2	9262	3	20.39	21.33	33	PASS
Band2	9262	4	20.37	21.31	33	PASS
Band2	9400	1	21.01	21.95	33	PASS
Band2	9400	2	20.50	21.44	33	PASS
Band2	9400	3	20.50	21.44	33	PASS
Band2	9400	4	20.48	21.42	33	PASS
Band2	9538	1	21.23	<b>22.17</b>	33	PASS
Band2	9538	2	20.72	21.66	33	PASS
Band2	9538	3	20.73	21.67	33	PASS
Band2	9538	4	20.70	21.64	33	PASS
Band5	4132	1	21.15	14.24	38.5	PASS
Band5	4132	2	20.72	13.81	38.5	PASS
Band5	4132	3	20.66	13.75	38.5	PASS
Band5	4132	4	20.61	13.70	38.5	PASS
Band5	4182	1	21.02	14.11	38.5	PASS
Band5	4182	2	20.57	13.66	38.5	PASS
Band5	4182	3	20.49	13.58	38.5	PASS
Band5	4182	4	20.47	13.56	38.5	PASS
Band5	4233	1	21.15	<b>14.24</b>	38.5	PASS
Band5	4233	2	20.74	13.83	38.5	PASS
Band5	4233	3	20.64	13.73	38.5	PASS
Band5	4233	4	20.63	13.72	38.5	PASS

**WCDMA Band 2 and Band 5 HSUPA :**

Band	Channel	Sub Test	Conducted Power(dBm)	ERP/EIRP(dBm)	Limit(dBm)	Verdict
Band2	9262	1	18.93	14.17	33	PASS
Band2	9262	2	19.40	14.64	33	PASS
Band2	9262	3	19.90	15.14	33	PASS
Band2	9262	4	18.90	14.14	33	PASS
Band2	9262	5	20.94	16.18	33	PASS
Band2	9400	1	19.07	14.31	33	PASS
Band2	9400	2	19.53	14.77	33	PASS
Band2	9400	3	20.02	15.26	33	PASS
Band2	9400	4	19.07	14.31	33	PASS
Band2	9400	5	21.06	16.30	33	PASS
Band2	9538	1	19.26	14.50	33	PASS
Band2	9538	2	19.73	14.97	33	PASS
Band2	9538	3	20.28	14.17	33	PASS
Band2	9538	4	19.27	14.64	33	PASS
Band2	9538	5	21.26	15.14	33	PASS
Band5	4132	1	19.10	19.97	38.5	PASS
Band5	4132	2	19.62	20.49	38.5	PASS
Band5	4132	3	20.12	20.99	38.5	PASS
Band5	4132	4	19.15	20.02	38.5	PASS
Band5	4132	5	21.12	21.99	38.5	PASS
Band5	4182	1	19.00	19.87	38.5	PASS
Band5	4182	2	19.46	20.33	38.5	PASS
Band5	4182	3	19.96	20.83	38.5	PASS
Band5	4182	4	18.98	19.85	38.5	PASS
Band5	4182	5	20.99	21.86	38.5	PASS
Band5	4233	1	19.13	20.00	38.5	PASS
Band5	4233	2	19.63	20.50	38.5	PASS
Band5	4233	3	20.11	19.97	38.5	PASS

Band5	4233	4	19.13	20.49	38.5	PASS
Band5	4233	5	21.14	20.99	38.5	PASS

**Note:**

For getting the EIRP (Efficient Isotropic Radiated Power), the following formula The following formula is used for calculation:

1. ERP [dBm] = Conducted Power [dBm] + Gain [dBd]

2. EIRP [dBm] = Conducted Power [dBm] + Gain [dBi]

## 6. Spurious Emission (Conducted and Radiated)

### 6.1. Measurement Result (Pre-measurement)

#### WCDMA BANDS

##### Band 2:

Test Channel	BW(MHz)	UL Channel	Frequency(MHz)	Judgment
Low Range	0.2	9262	1852.4	Pass
Middle Range	0.2	9400	1880.0	Pass
High Range	0.2	9538	1907.6	Pass

##### BAND 5:

Test Channel	BW(MHz)	UL Channel	Frequency(MHz)	Judgment
Low Range	5	4132	826.4	Pass
Middle Range	5	4182	836.4	Pass
High Range	5	4233	846.6	Pass



**Test Plot(s)**  
**Conducted method**

**Test limit:**

The spurious (unwanted) emission limits specified in the individual FCC rule parts applicable to licensed digital transmitters (typically referred to under the heading 'emission limits') normally apply to any and all emissions that are present outside of the authorized frequency band/block and apply to emissions in both the out-of-band and spurious domains. In some rule parts, the unwanted emission limits are specified by an emission mask that defines the applicable limit as a function of the frequency range relative to the authorized frequency block.

Typically, unwanted emissions are required by the licensed rule parts to be attenuated below the transmitter power by a factor of at least  $X + 10\log(P)$  dB, where P represents the transmitter power expressed in watts and X is a specified scalar value (e.g., 43). This specification can be interpreted in one of two equivalent ways. First, the required attenuation can be construed to be relative to the mean carrier power, with the resultant of the equation  $X + 10\log(P)$  being expressed in dBc (dB relative to the maximum carrier power). Alternatively, the specification can be interpreted as an absolute limit when the specified attenuation is actually subtracted from the maximum permissible transmitter power [i.e.,  $10\log(P) - \{X + 10\log(P)\}$ ], resulting in an absolute level of -X dBW [or  $(-X + 30)$  dBm]. See section 4.

**Test procedure:**

The RF output of the transceiver was connected to a spectrum analyzer and simulator through appropriate attenuation. The resolution bandwidth of the spectrum analyzer was set at 100 kHz below 1 GHz and 1 MHz above 1 GHz. Sufficient scans were taken to show any out of band emissions up to 10th harmonics.

**Conducted Emission Test-Up:**

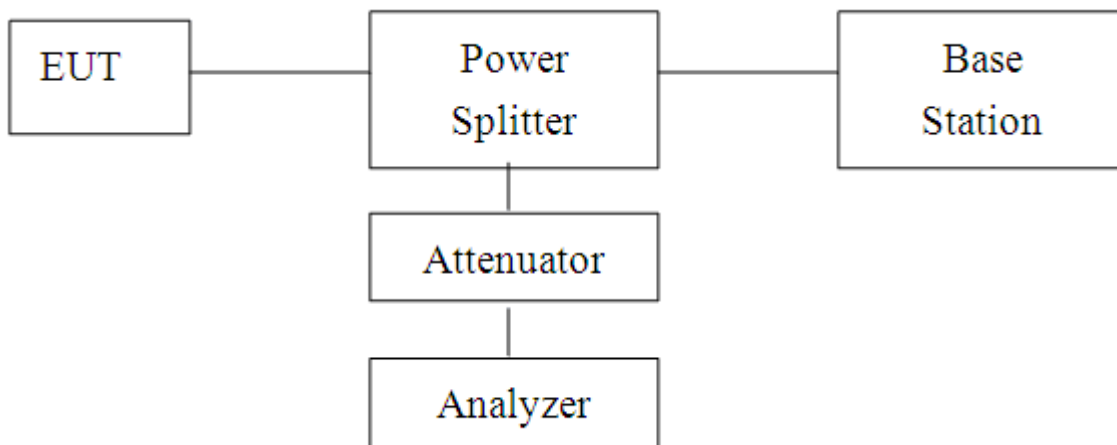

**Test Result:**

Band	Channel	Frequency Range (Mhz)	Frequency (dBm)	Result (dBm)	Limit (dBm)	Verdict
Band2	9262	0.009~0.15MHz	0.01	-67.19	-43	PASS
Band2	9262	0.15~30MHz	0.16	-53.28	-23	PASS
Band2	9262	30~1000MHz	940.8	-57.1	-13	PASS
Band2	9262	1000~3000MHz	2676.8	-52.36	-13	PASS
Band2	9262	3000~20000MHz	17010.27	-40.83	-13	PASS
Band2	9400	0.009~0.15MHz	0.01	-66.9	-43	PASS
Band2	9400	0.15~30MHz	0.15	-53.31	-23	PASS
Band2	9400	30~1000MHz	491.04	-57.79	-13	PASS
Band2	9400	1000~3000MHz	2684.67	-52.3	-13	PASS
Band2	9400	3000~20000MHz	17015.37	-40.84	-13	PASS
Band2	9538	0.009~0.15MHz	0.01	-66.46	-43	PASS
Band2	9538	0.15~30MHz	0.15	-52.58	-23	PASS
Band2	9538	30~1000MHz	782.78	-57.44	-13	PASS
Band2	9538	1000~3000MHz	2679.67	-52.34	-13	PASS
Band2	9538	3000~20000MHz	17028.4	-40.85	-13	PASS
Band5	4132	0.009~0.15MHz	0.01	-66.79	-33	PASS
Band5	4132	0.15~30MHz	0.15	-52.75	-13	PASS
Band5	4132	30~1000MHz	974.52	-66.33	-13	PASS
Band5	4132	1000~10000MHz	3186.7	-48.99	-13	PASS
Band5	4182	0.009~0.15MHz	0.01	-66.21	-33	PASS
Band5	4182	0.15~30MHz	0.15	-54.34	-13	PASS
Band5	4182	30~1000MHz	970.51	-66.17	-13	PASS
Band5	4182	1000~10000MHz	3178.3	-48.98	-13	PASS
Band5	4233	0.009~0.15MHz	0.01	-66.2	-33	PASS
Band5	4233	0.15~30MHz	0.15	-54.7	-13	PASS
Band5	4233	30~1000MHz	534.79	-67.5	-13	PASS
Band5	4233	1000~10000MHz	3180.7	-48.96	-13	PASS

Test Graphs:

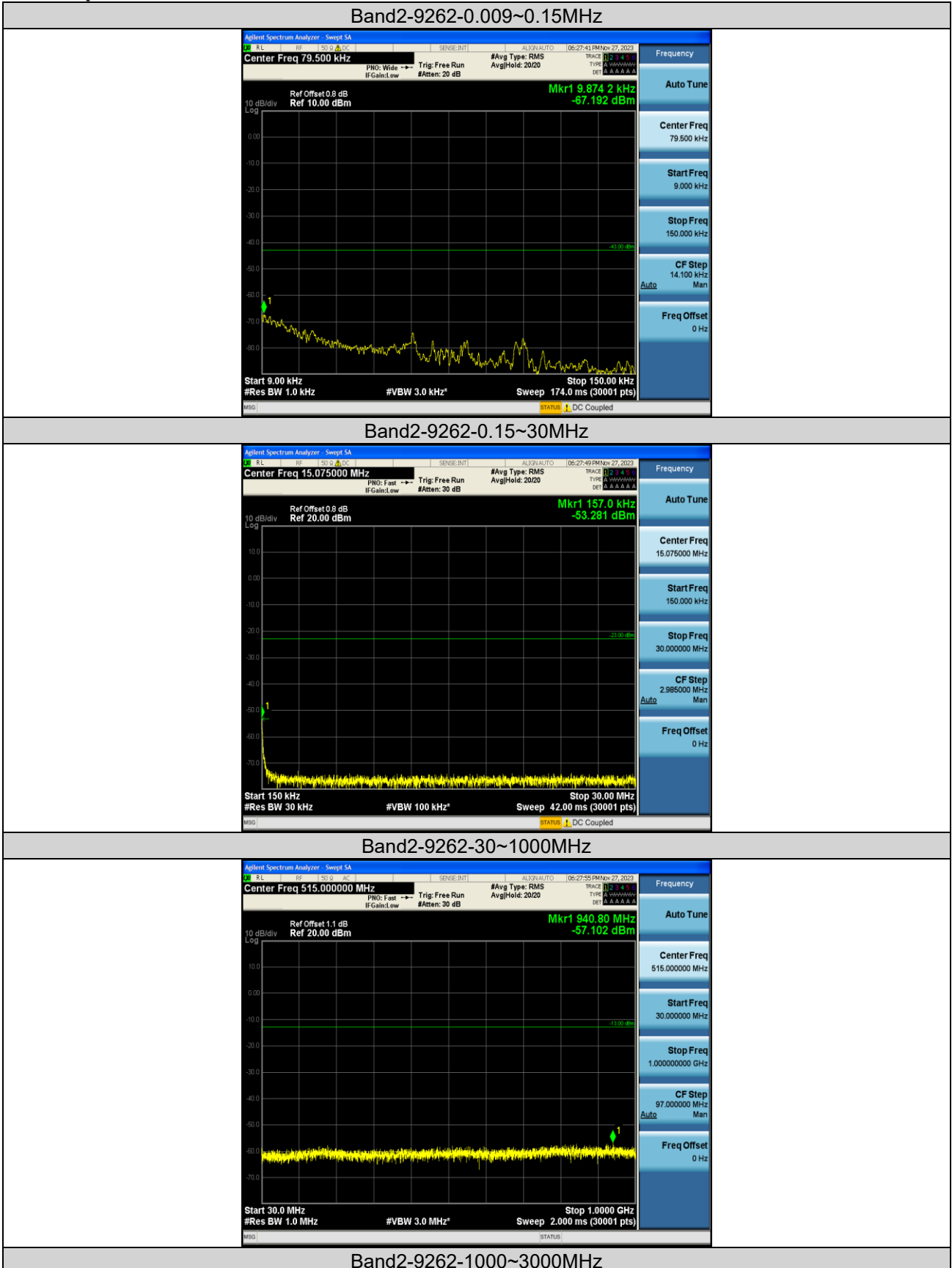

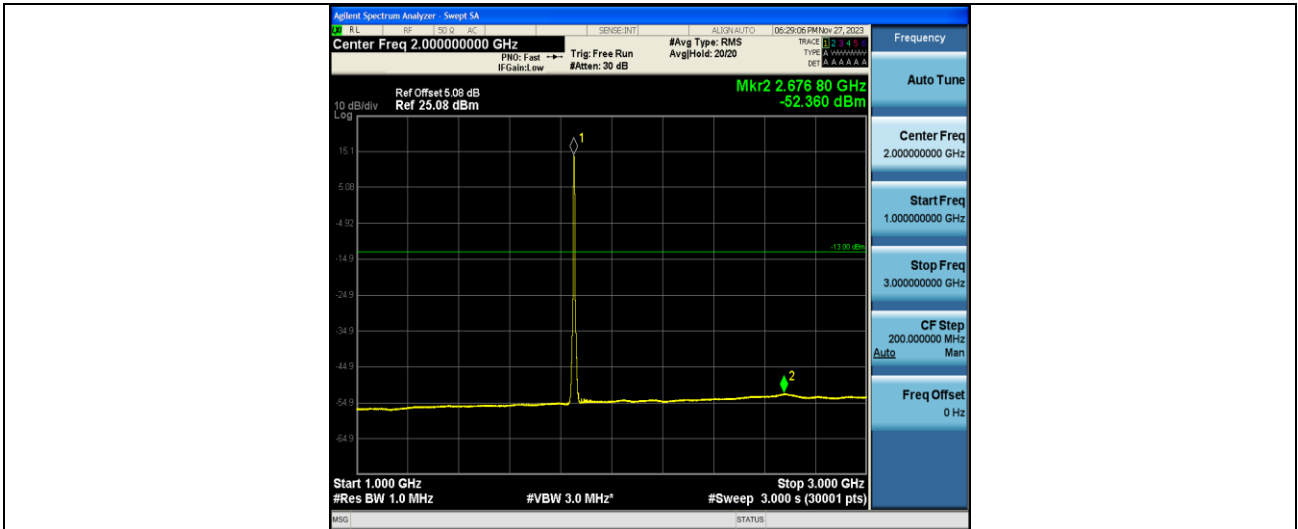

Band2-9262-3000~20000MHz



Band2-9400-0.009~0.15MHz



Band2-9400-0.15~30MHz

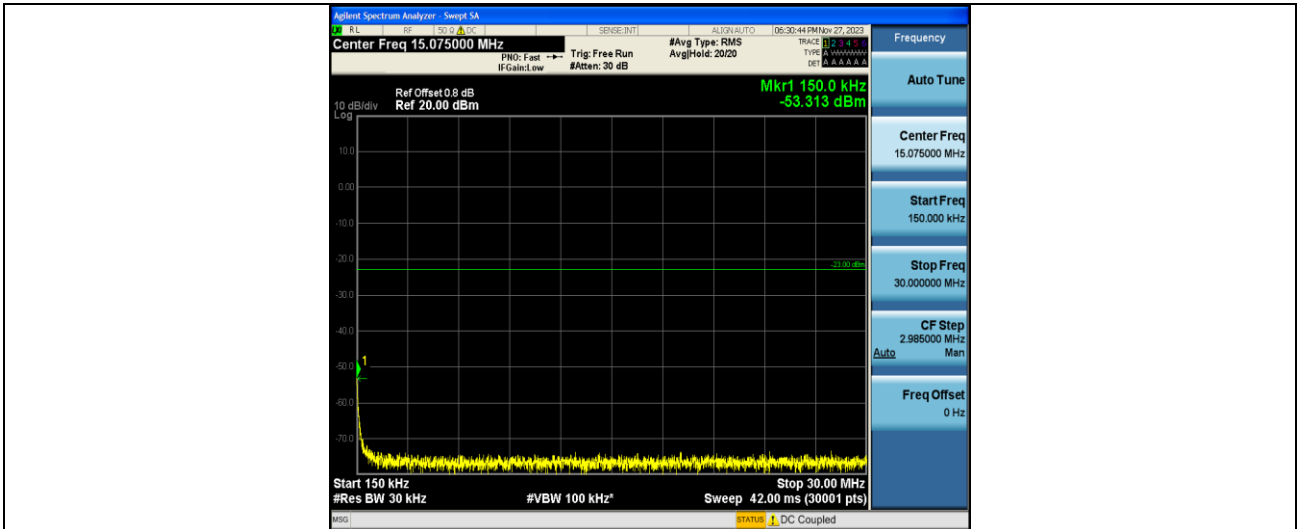

Band2-9400-30~1000MHz

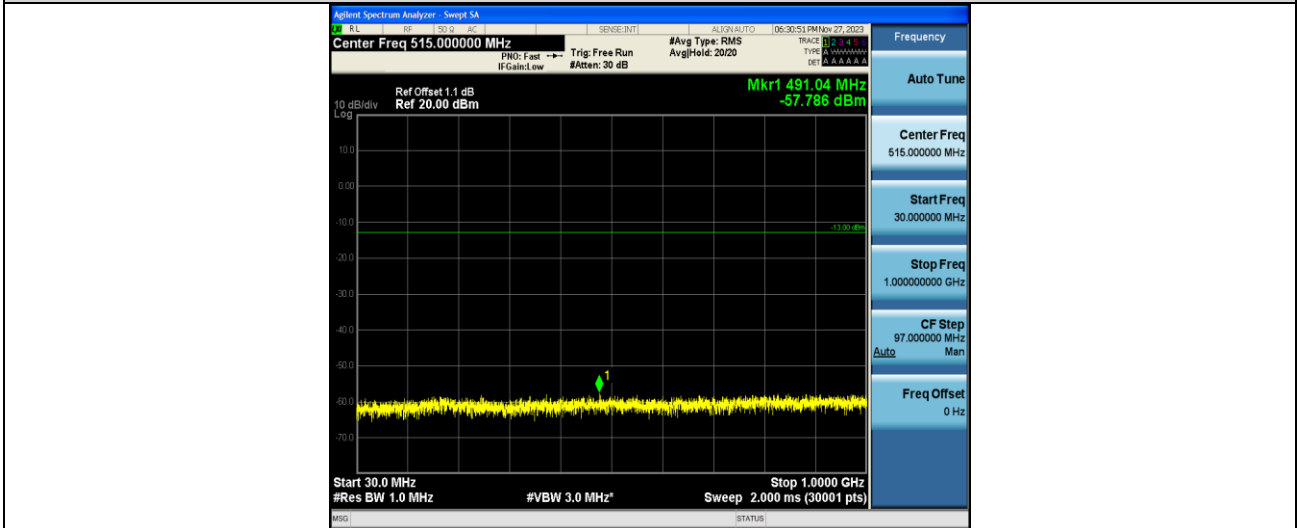

Band2-9400-1000~3000MHz

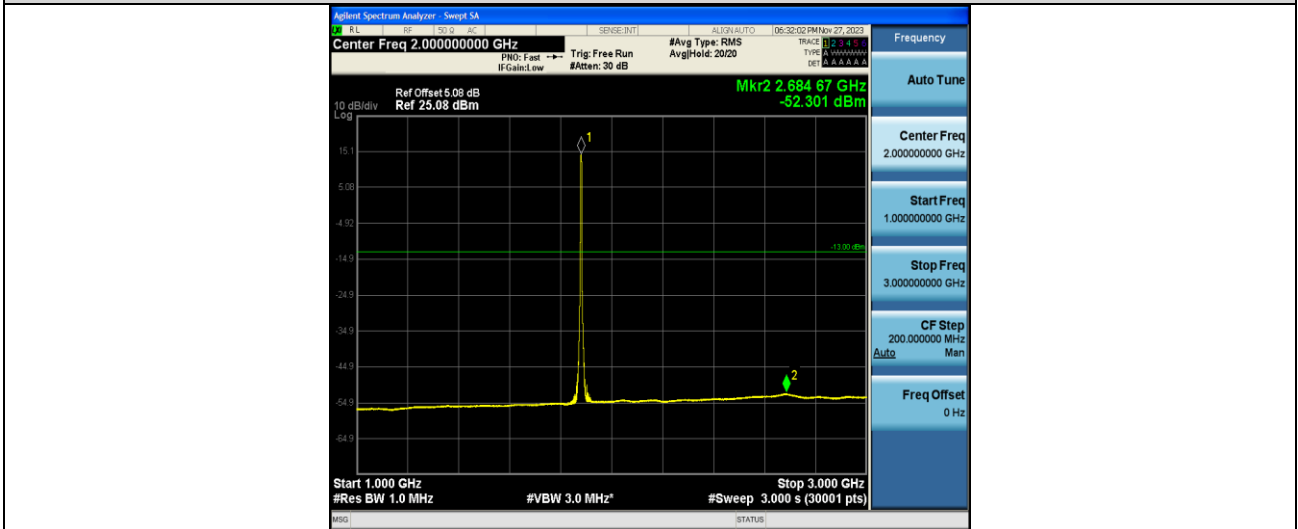

Band2-9400-3000~20000MHz



Band2-9538-0.009~0.15MHz



Band2-9538-0.15~30MHz

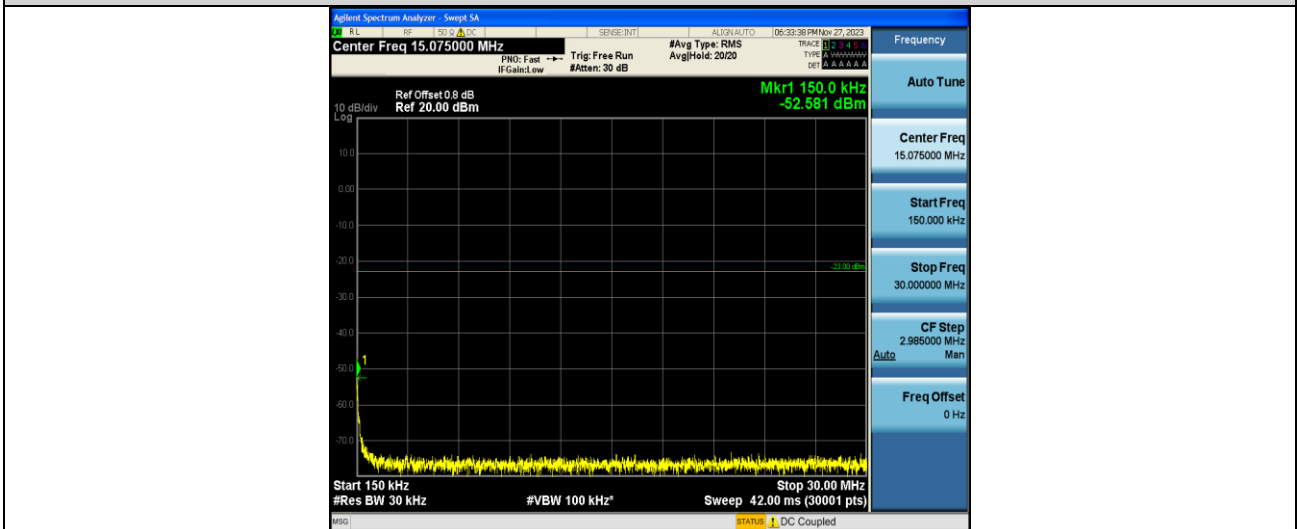

Band2-9538-30~1000MHz

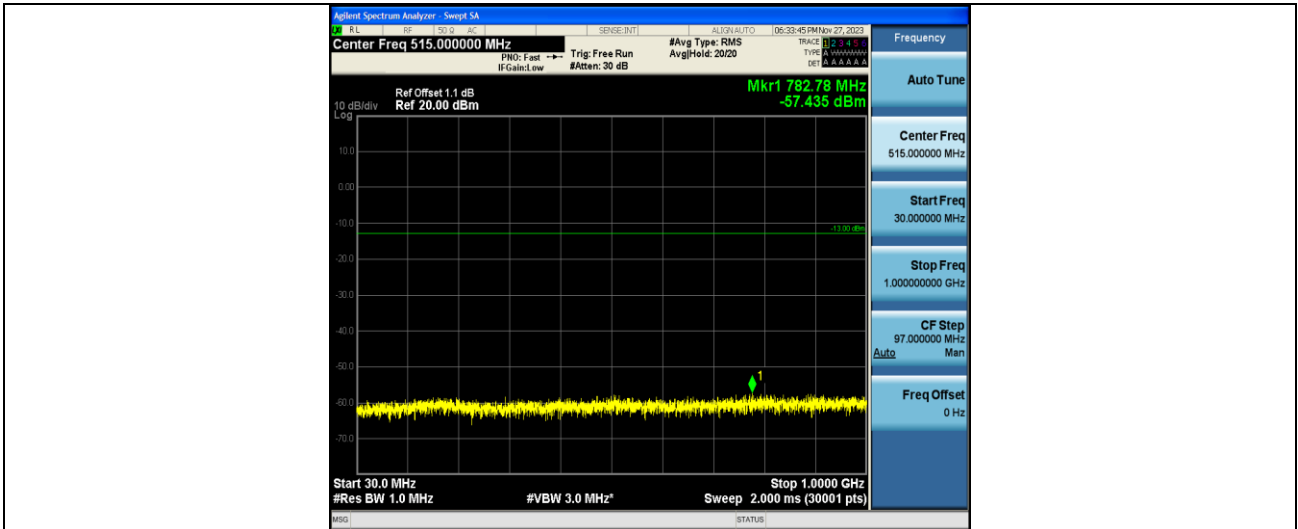

Band2-9538-1000~3000MHz

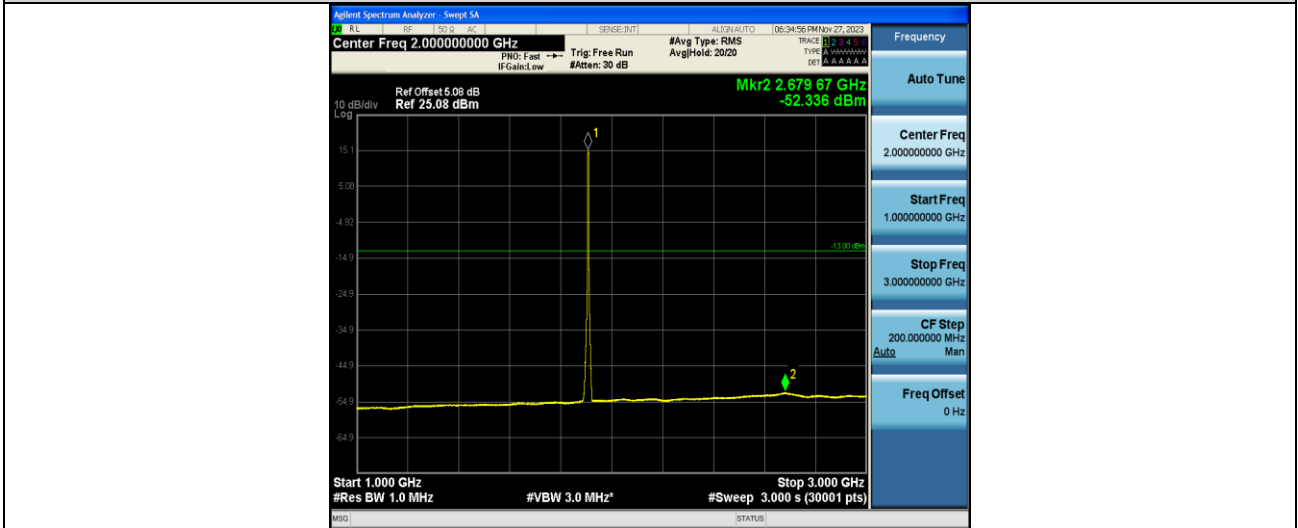

Band2-9538-3000~20000MHz



Band5-4132-0.009~0.15MHz



Band5-4132-0.15~30MHz

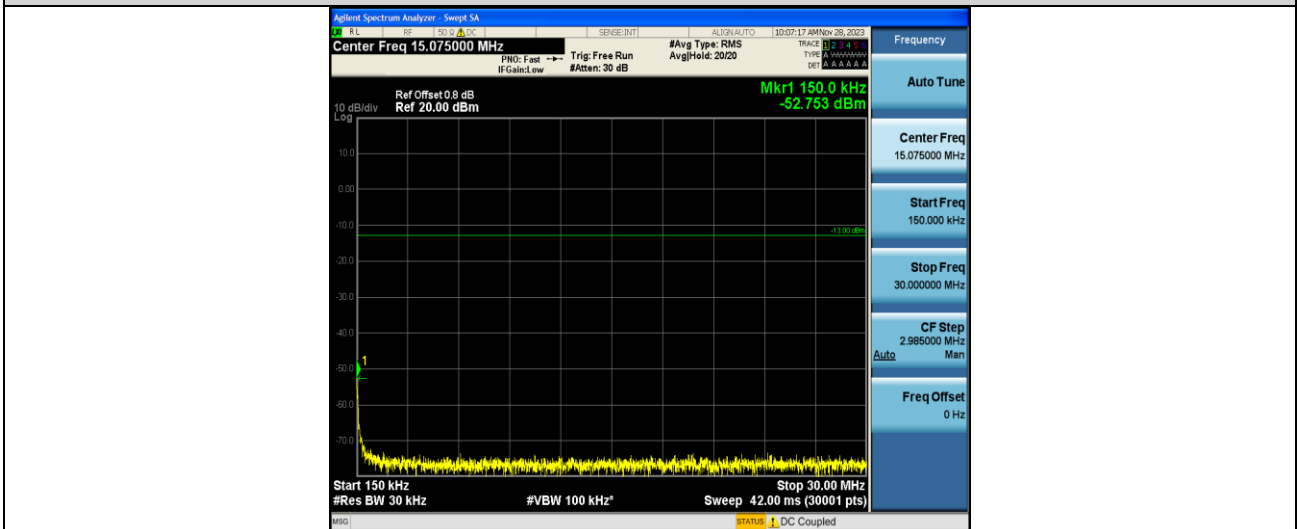

Band5-4132-30~1000MHz

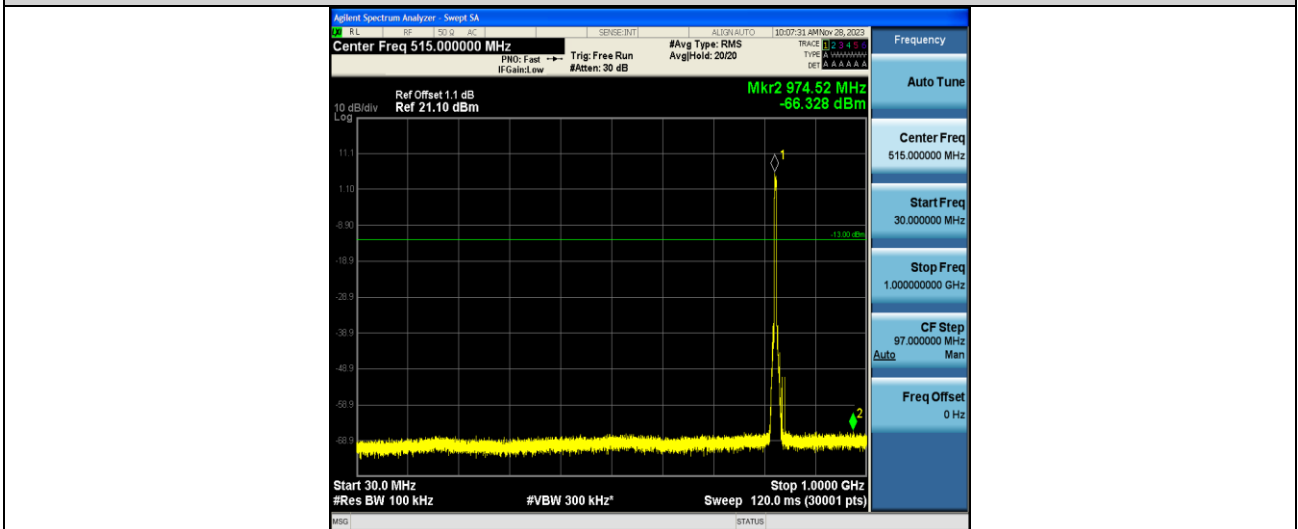

Band5-4132-1000~10000MHz





Band5-4182-0.009~0.15MHz



Band5-4182-0.15~30MHz

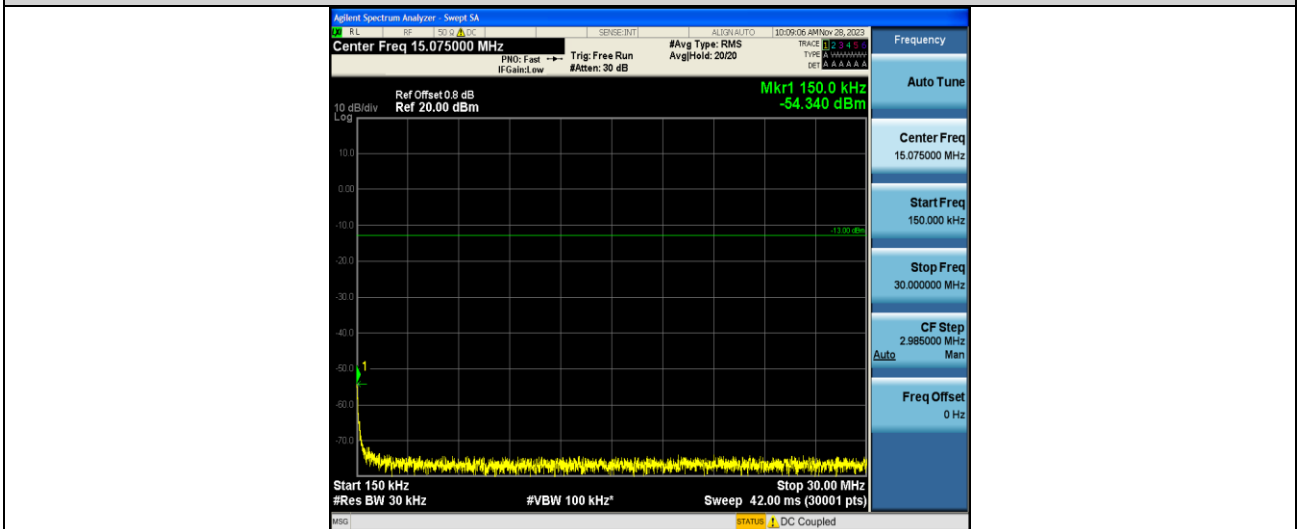

Band5-4182-30~1000MHz

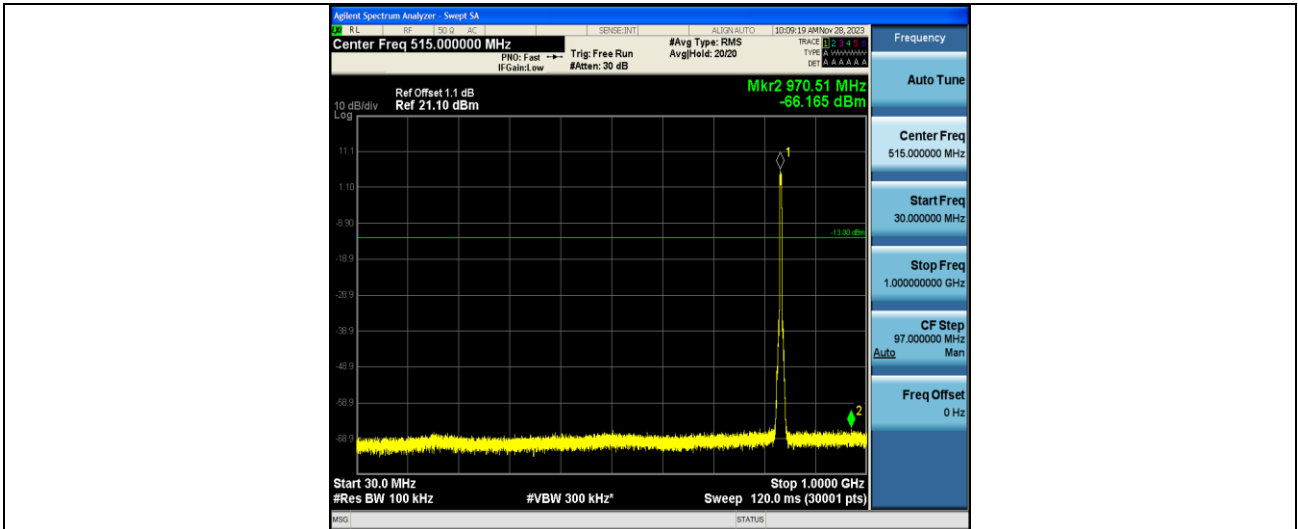

Band5-4182-1000~10000MHz



Band5-4233-0.009~0.15MHz



Band5-4233-0.15~30MHz

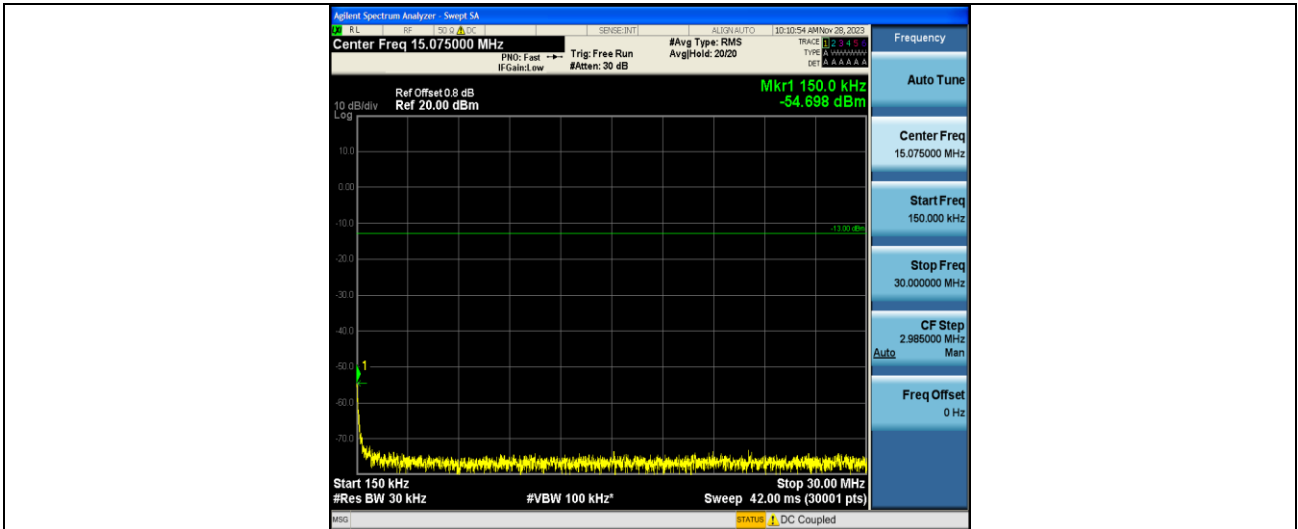

Band5-4233-30~1000MHz

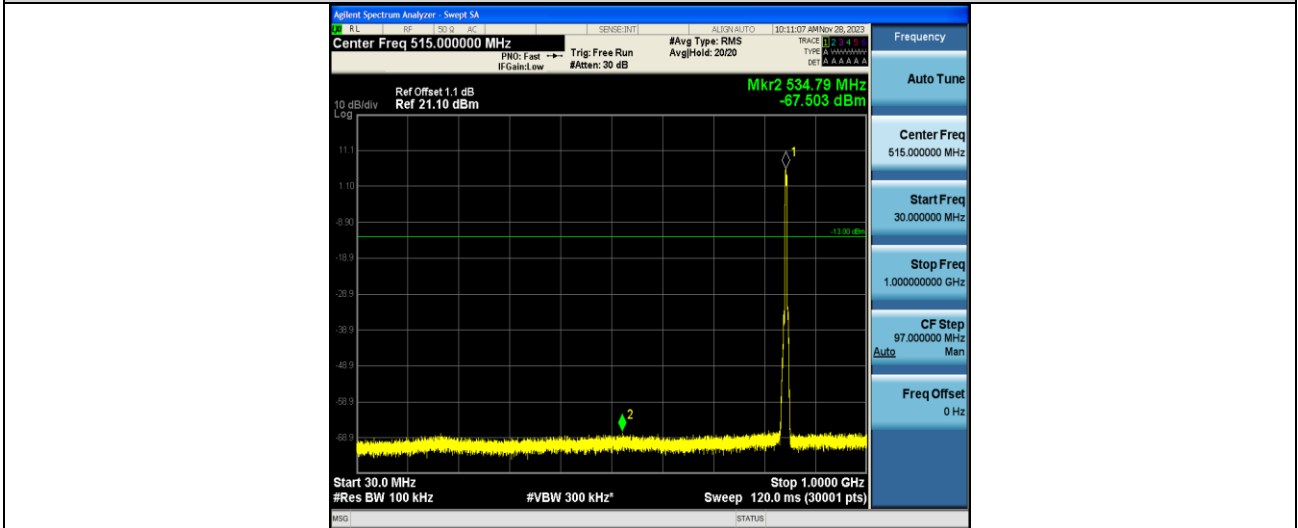

Band5-4233-1000~10000MHz

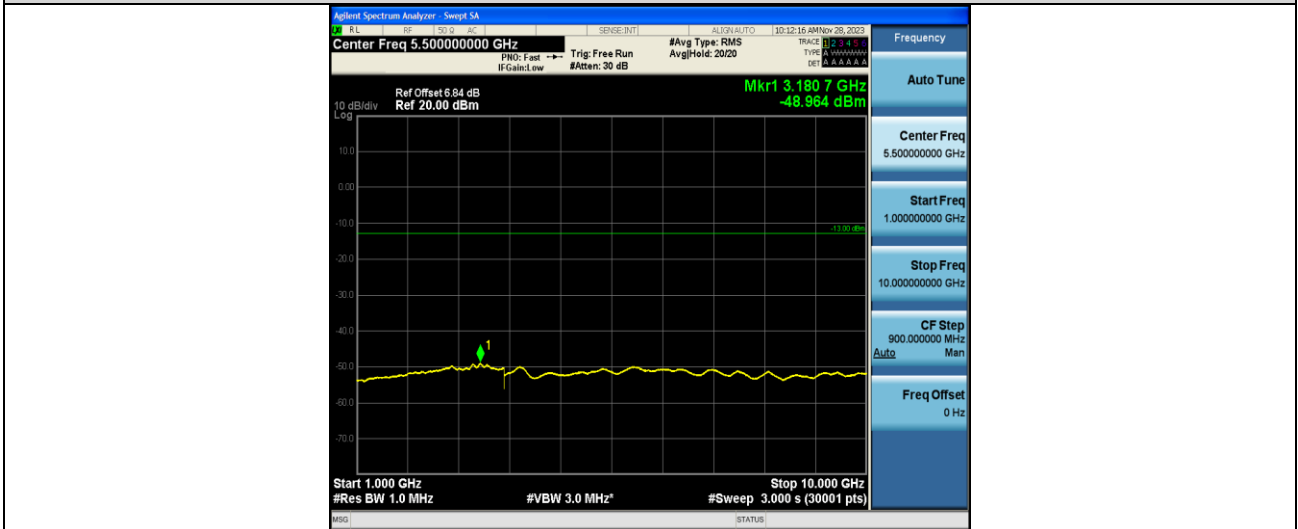

**Radiated method**

**Test limit:**

The spurious (unwanted) emission limits specified in the individual FCC rule parts applicable to licensed digital transmitters (typically referred to under the heading 'emission limits') normally apply to any and all emissions that are present outside of the authorized frequency band/block and apply to emissions in both the out-of-band and spurious domains. In some rule parts, the unwanted emission limits are specified by an emission mask that defines the applicable limit as a function of the frequency range relative to the authorized frequency block.

Typically, unwanted emissions are required by the licensed rule parts to be attenuated below the transmitter power by a factor of at least  $X + 10\log(P)$  dB, where P represents the transmitter power expressed in watts and X is a specified scalar value (e.g., 43). This specification can be interpreted in one of two equivalent ways. First, the required attenuation can be construed to be relative to the mean carrier power, with the resultant of the equation  $X + 10\log(P)$  being expressed in dBc (dB relative to the maximum carrier power). Alternatively, the specification can be interpreted as an absolute limit when the specified attenuation is actually subtracted from the maximum permissible transmitter power [i.e.,  $10\log(P) - \{X + 10\log(P)\}$ ], resulting in an absolute level of -X dBW [or  $(-X + 30)$  dBm]. See section 4.

**Test procedure:**

The radiated emission tests were performed in the 3m Semi- Anechoic Chamber test site. The resolution bandwidth of the spectrum analyzer was set at 100 kHz below 1 GHz and 1 MHz above 1 GHz. Sufficient scans were taken to show any out of band emissions up to 10th harmonics.

**Test setup:**

(A) Radiated Emission Test-Up Frequency 30MHz~1GHz

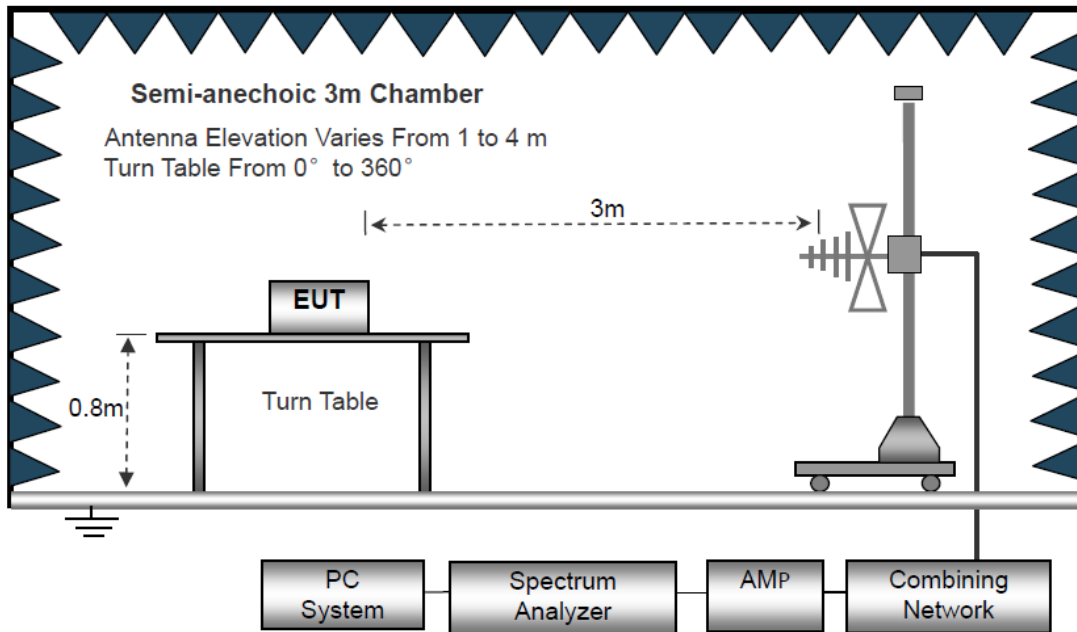

(B) Radiated Emission Test-Up Frequency Above 1GHz

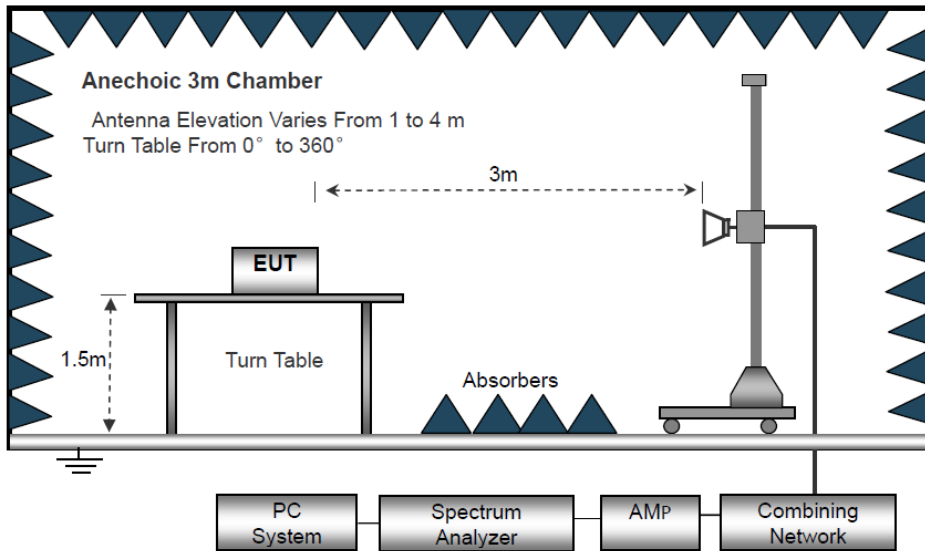

**Note:**

1, Below 30MHz no Spurious found.

2, UE is positioned at 3 axis at the pre-scan stage, and only the measurement of the worst case is reported in this part.

**List of final test modes:  
WCDMA band II:**

Mode	UL Channel	Frequency	Judgement
1	9262	1852.4	Pass
2	9400	1880.0	Pass
3	9538	1907.6	Pass

**WCDMA band V:**

Mode	UL Channel	Frequency	Judgement
1	4132	826.4	Pass
2	4183	836.6	Pass
3	4233	846.6	Pass

**Note:** All modes have been tested and only the worst modes are recorded in the report.

**Test record:****WCDMA band II:****Middle Channel**

Frequency(MHz)	Reading level(dBm)	Factor(dB)	Level (dBm)	Limit (dBm)	Margin (dBm)	Polarity
3760.00	-49.97	-1.04	-51.01	-13.00	38.01	Horizontal
5640.00	-50.75	6.05	-44.70	-13.00	31.70	Horizontal
3760.00	-49.71	-1.04	-50.75	-13.00	37.75	Vertical
5640.00	-50.40	6.05	-44.35	-13.00	31.35	Vertical

**Note:**1. Level= Reading level+ Factor. Margin=Limit-Level.

2. The emission levels of below 1 GHz are lower than the limit 10dB, so not show in test report.

**WCDMA band V:****Highest Channel**

Frequency(MHz)	Reading level(dBm)	Factor(dB)	Level (dBm)	Limit (dBm)	Margin (dBm)	Polarity
1693.20	-48.53	-11.08	-59.61	-13.00	46.61	Horizontal
2546.40	-40.29	-6.35	-46.64	-13.00	33.64	Horizontal
3386.40	-47.21	-5.17	-52.38	-13.00	39.38	Horizontal
1693.20	-49.43	-11.08	-60.51	-13.00	47.51	Vertical
2546.40	-30.62	-6.35	-36.97	-13.00	23.97	Vertical
3386.40	-46.98	-5.17	-52.15	-13.00	39.15	Vertical

**Note:**1. Level= Reading level+ Factor. Margin=Limit-Level.

2. The emission levels of below 1 GHz are lower than the limit 10dB, so not show in test report.

## 7. Occupied Bandwidth and Emission Bandwidth

### Test limit:

The occupied bandwidth (OBW), that is the frequency bandwidth such that, below its lower and above its upper frequency limits, the mean powers radiated are each equal to 0.5 percent of the total mean power radiated by a given emission, shall be measured when modulated by an input signal such that its amplitude and symbol rate represent the maximum rated conditions under which the equipment will be operated. The signal shall be applied through any filter networks, pseudo-random generators or other devices required in normal service. Additionally, the occupied bandwidth shall be shown for operation with any devices used for modifying the spectrum when such devices are optional at the discretion of the user. [i2.1049(h)]

Many of the individual rule parts specify a relative OBW in lieu of the 99% OBW. In such cases, the OBW is defined as the width of the signal between two points, one below the carrier center frequency and one above the carrier center frequency, outside of which all emissions are attenuated by at least X dB below the transmitter power, where the value of X is typically specified as 26.

The relative OBW must be measured and reported when it is specified in the applicable rule part; otherwise, the 99% OBW shall be measured and reported. The test report shall specify which OBW is reported.

A spectrum/signal analyzer or other instrument providing a spectral display is recommended for these measurements and the video bandwidth shall be set to a value at least three times greater than the IF/resolution bandwidth to avoid any amplitude smoothing. Video filtering shall not be used during occupied bandwidth tests.

The OBW shall be measured for all operating conditions that will affect the bandwidth results (e.g. variable modulations, coding, or channel bandwidth settings). See section 4.

### Test procedure:

#### Occupied bandwidth – relative measurement procedure

The reference value is the highest level of the spectral envelope of the modulated signal.

a) The spectrum analyzer center frequency is set to the nominal EUT channel center frequency. The span range for the spectrum analyzer shall be between two and five times the anticipated OBW.

b) The nominal resolution bandwidth (RBW) shall be in the range of 1 to 5 % of the anticipated OBW, and the VBW shall be at least 3 times the RBW.

c) Set the reference level of the instrument as required to prevent the signal from exceeding the maximum input mixer level for linear operation. In general, the peak of the spectral envelope must be at least  $10\log(\text{OBW} / \text{RBW})$  below the reference level.

d) NOTE—Steps a) through c) may require iteration to adjust within the specified tolerances.

e) The dynamic range of the spectrum analyzer at the selected RBW shall be at least 10 dB below the target “-X dB down” requirement (i.e., if the requirement calls for measuring the -26 dB OBW, the spectrum analyzer noise floor at the selected RBW shall be at least 36 dB below the reference value).

f) Set the detection mode to peak, and the trace mode to max hold.

g) Determine the reference value: Set the EUT to transmit a modulated signal. Allow the trace to stabilize. Set the spectrum analyzer marker to the highest level of the displayed trace (this is the reference value).

h) Determine the “-X dB down amplitude” as equal to (Reference Value – X). Alternatively,



this calculation can be performed by the analyzer by using the marker-delta function.

i) Place two markers, one at the lowest and the other at the highest frequency of the envelope of the spectral display such that each marker is at or slightly below the “-X dB down amplitude” determined in step g). If a marker is below this “-X dB down amplitude” value it shall be placed as close as possible to this value. The OBW is the positive frequency difference between the two markers.

j) The occupied bandwidth shall be reported by providing plot(s) of the measuring instrument display. The frequency and amplitude axes and scale shall be clearly labeled. Tabular data may be reported in addition to the plot(s).

Occupied bandwidth – power bandwidth (99%) measurement procedure

The following procedure shall be used for measuring (99 %) power bandwidth

a) The spectrum analyzer center frequency is set to the nominal EUT channel center frequency. The frequency span for the spectrum analyzer shall be set wide enough to capture all modulation products including the emission skirts (i.e., two to five times the OBW).

b) The nominal IF filter bandwidth (3 dB RBW) shall be in the range of 1 to 5 % of the anticipated OBW, and the VBW shall be at least 3 times the RBW.

c) Set the reference level of the instrument as required to keep the signal from exceeding the maximum input mixer level for linear operation. In general, the peak of the spectral envelope must be at least  $10\log(\text{OBW} / \text{RBW})$  below the reference level.

d) NOTE—Steps a) through c) may require iteration to adjust within the specified tolerances.

e) Set the detection mode to peak, and the trace mode to max hold..

f) Use the 99 % power bandwidth function of the spectrum analyzer (if available) and report the measured bandwidth.

g) If the instrument does not have a 99 % power bandwidth function, the trace data points are to be recovered and directly summed in linear power terms. The recovered amplitude data points, beginning at the lowest frequency, are placed in a running sum until 0.5 % of the total is reached; that frequency is recorded as the lower frequency. The process is repeated until 99.5 % of the total is reached; that frequency is recorded as the upper frequency. The 99 % power bandwidth is the difference between these two frequencies.

h) The OBW shall be reported by providing plot(s) of the measuring instrument display. The frequency and amplitude axes and scale shall be clearly labeled. Tabular data may be reported in addition to the plot(s).

Test setup:

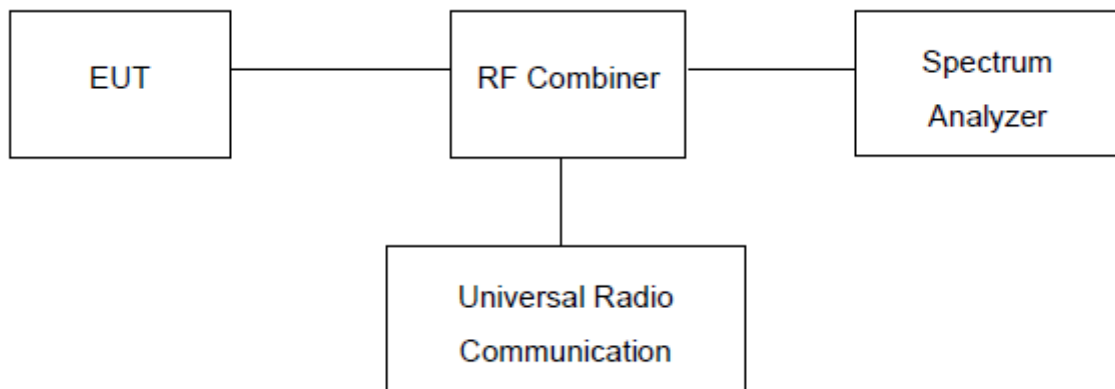

### Measurement Result

Band	Channel	Occupied Bandwidth (kHz)	26dB Bandwidth (kHz)	Limit(kHz)	Verdict
Band2	9262	4.2006	4.737	---	PASS
Band2	9400	4.1966	4.746	---	PASS
Band2	9538	4.1867	4.729	---	PASS
Band5	4132	4.1872	4.710	---	PASS
Band5	4182	4.1804	4.722	---	PASS
Band5	4233	4.1859	4.733	---	PASS

### Test Graphs:

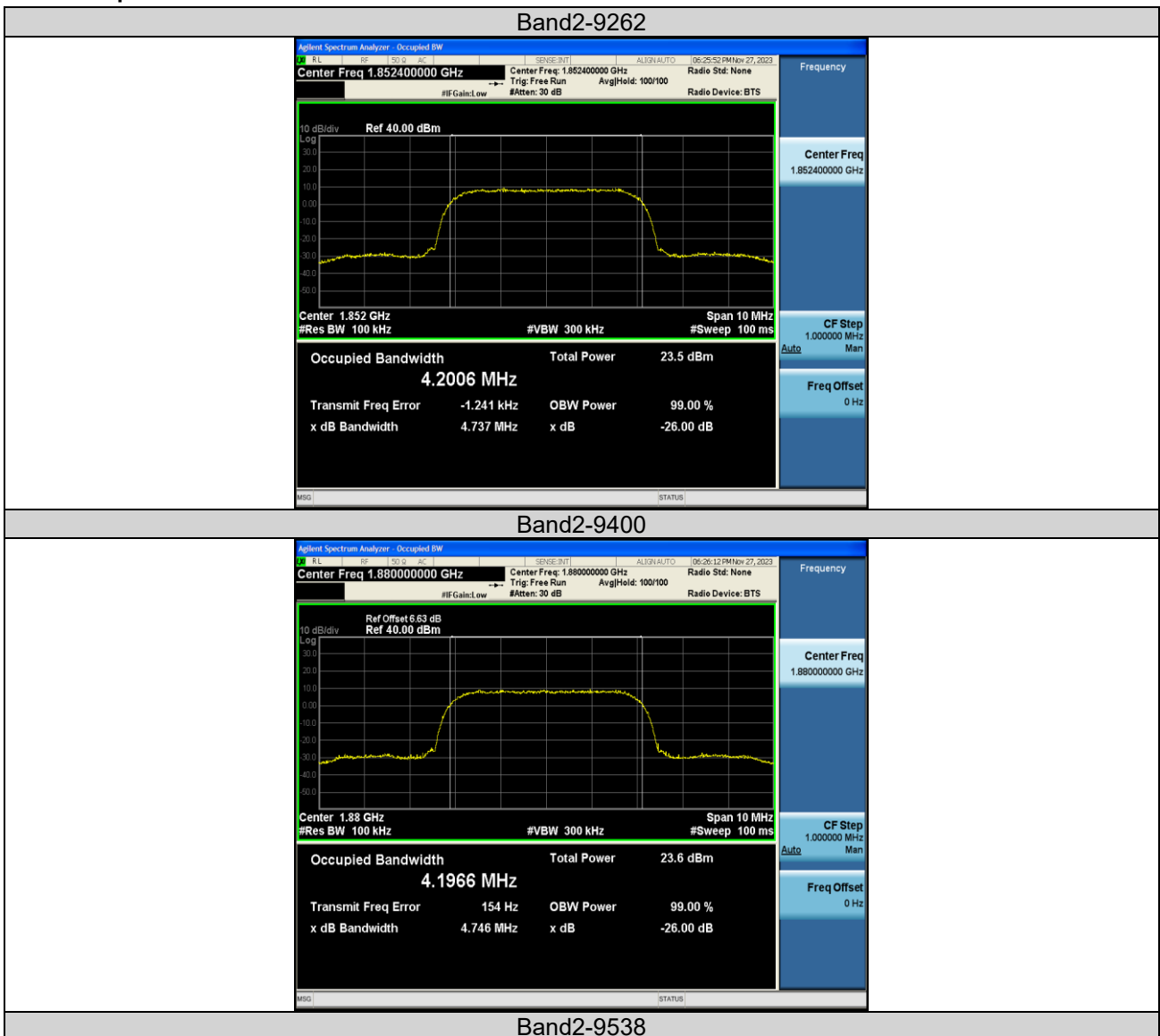

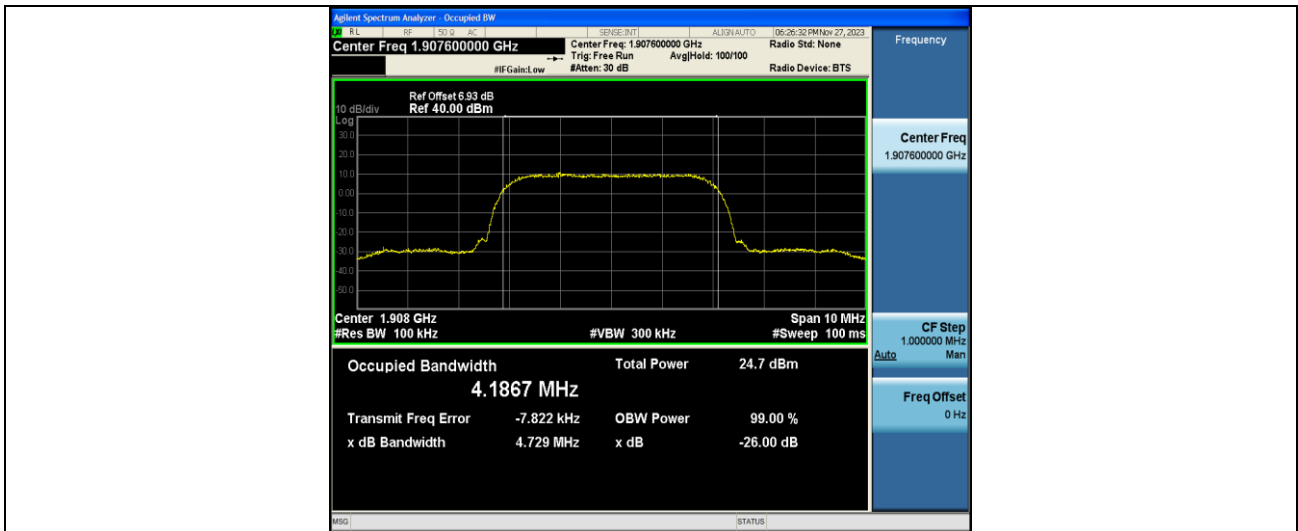

Band5-4132

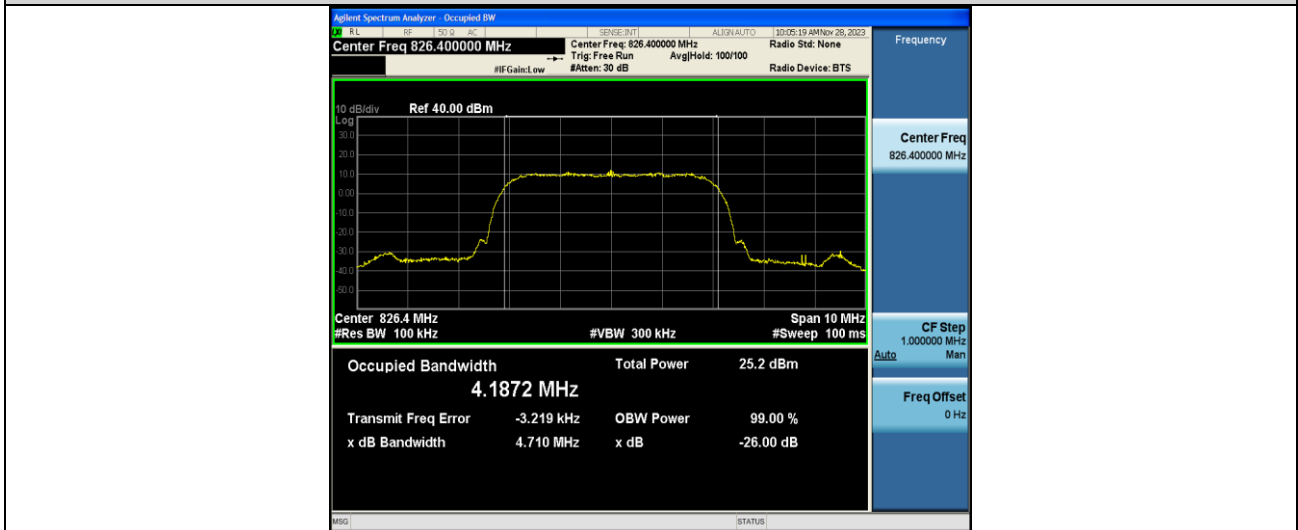

Band5-4182

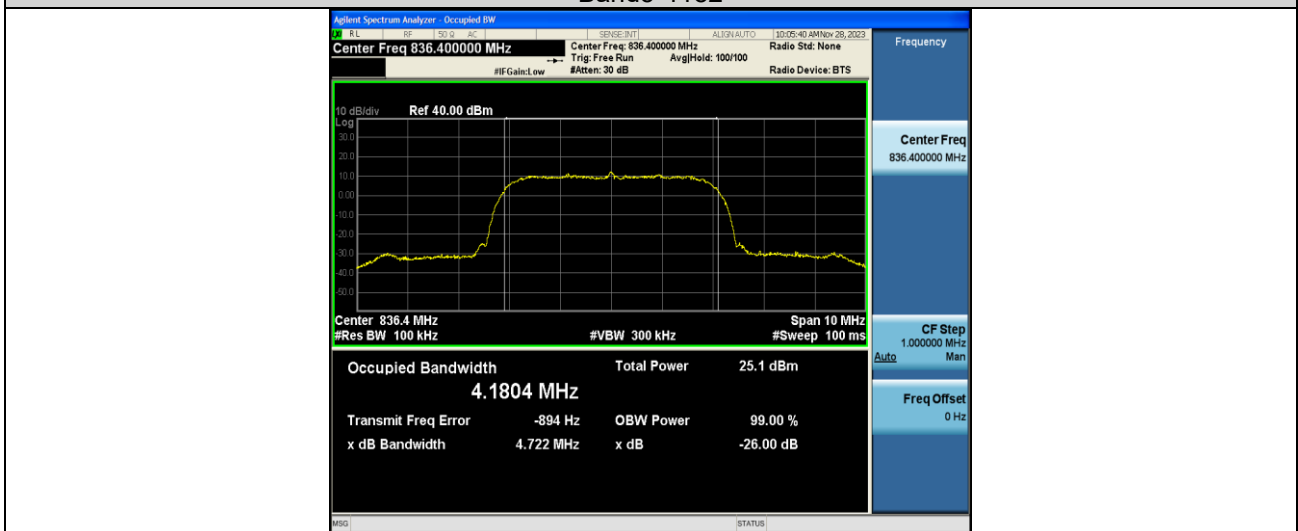

Band5-4233

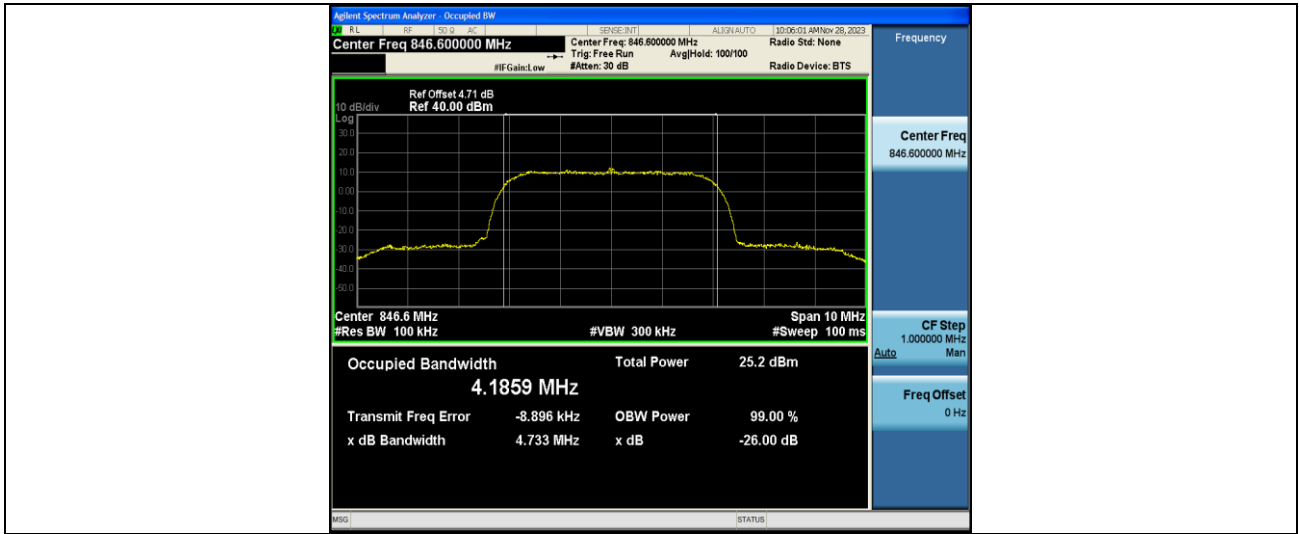

## 8. Band Edge

Test Limit:

The radio frequency voltage or powers generated within the equipment and appearing on a spurious frequency shall be checked at the equipment output terminals when properly loaded with a suitable artificial antenna. Curves or equivalent data shall show the magnitude of each harmonic and other spurious emission that can be detected when the equipment is operated under the conditions specified in §2.1049 as appropriate. The magnitude of spurious emissions which are attenuated more than 20 dB below the permissible value need not be specified. See section 4.

Test procedure:

The RF output of the transmitter was connected to the input of the spectrum analyzer through sufficient attenuation.

Test setup:

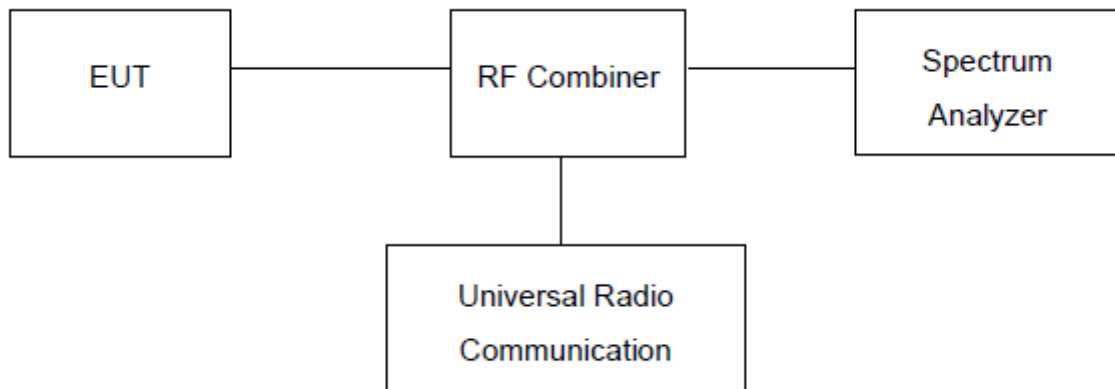

**Measurement Result:**

Band	Channel	Frequency (MHz)	Result (dBm)	Limit(dBm)	Verdict
Band2	9262	1850.00	-25.66	-13	PASS
Band2	9538	1910.01	-24.85	-13	PASS
Band5	4132	824.00	-25.38	-13	PASS
Band5	4233	849.00	-24.02	-13	PASS

Test Graphs:

Band2-9262

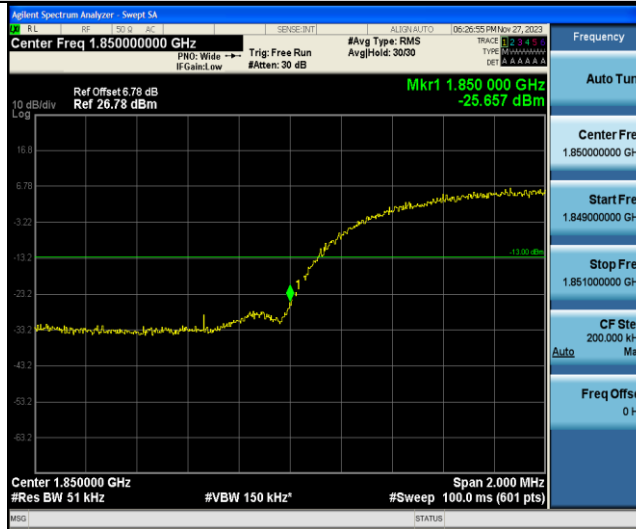

Band2-9538



Band5-4132

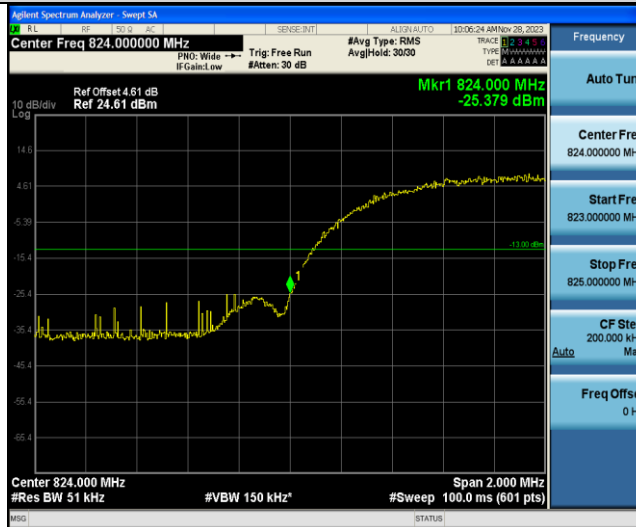

Band5-4233





## 9. Peak-to-Average Ratio(PAR)

### Limit

The Peak-to-Average Ratio (PAR) of the transmission may not exceed 13 dB.

### Test Configuration:

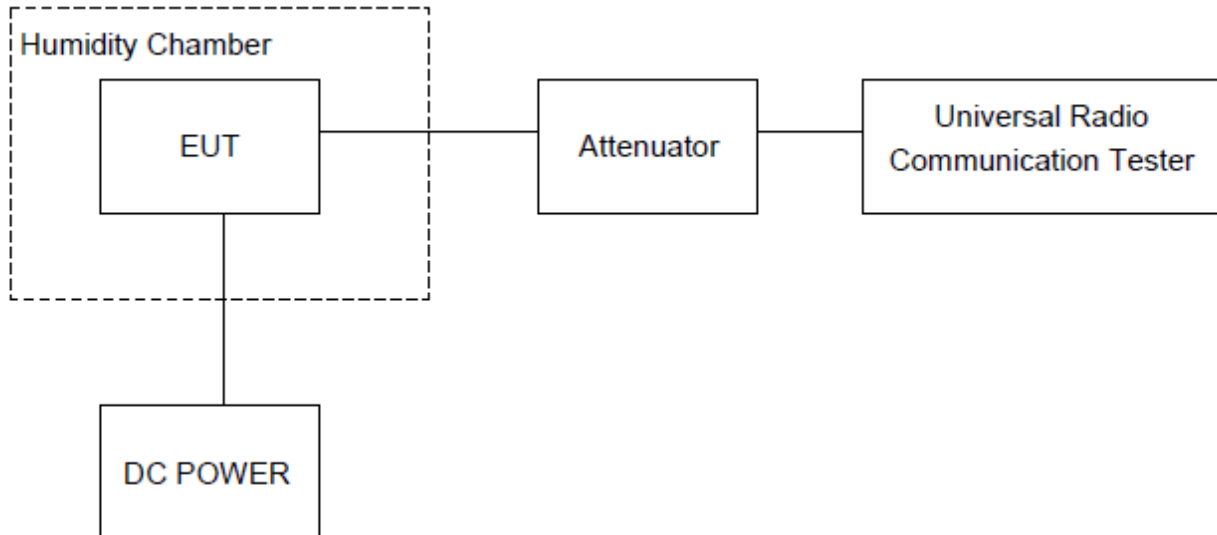

### Test Procedure:

1. Refer to instrument's analyzer instruction manual for details on how to use the power statistics/CCDF function;
2. Set resolution/measurement bandwidth  $\geq$  signal's occupied bandwidth;
3. Set the number of counts to a value that stabilizes the measured CCDF curve;
4. Set the measurement interval as follows:
  - 1). for continuous transmissions, set to 1 ms,
  - 2). for burst transmissions, employ an external trigger that is synchronized with the EUT burst timing sequence, or use the internal burst trigger with a trigger level that allows the burst to stabilize and set the measurement interval to a time that is less than or equal to the burst duration.
5. Record the maximum PAPR level associated with a probability of 01%

**Test Result:**

Band	Channel	Peak-to-Average Ratio(dB)	Limit(dBm)	Verdict
Band2	9262	2.85	13	PASS
Band2	9400	2.86	13	PASS
Band2	9538	2.92	13	PASS
Band5	4132	2.98	13	PASS
Band5	4182	2.82	13	PASS
Band5	4233	2.69	13	PASS

Test Graphs:

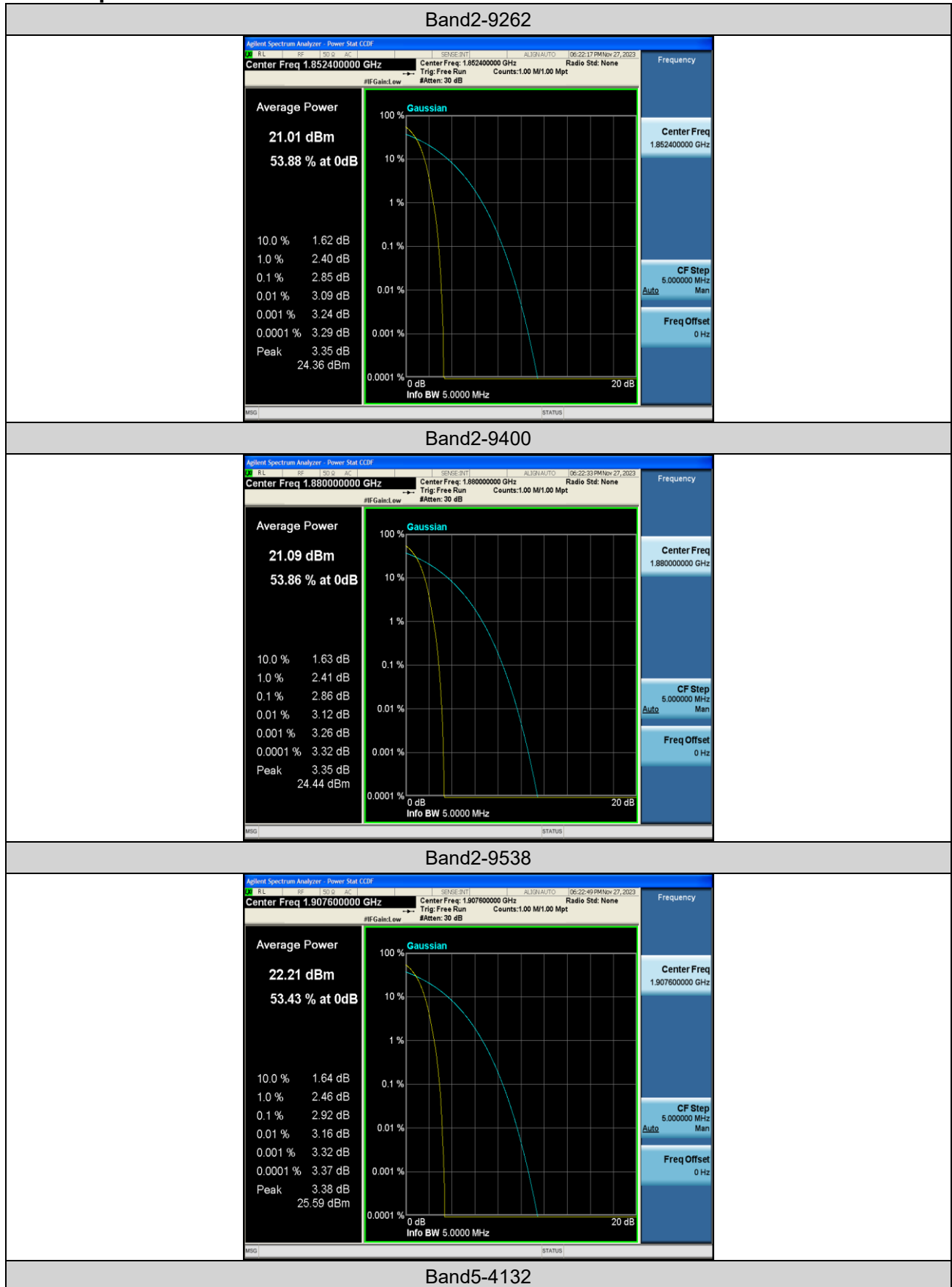

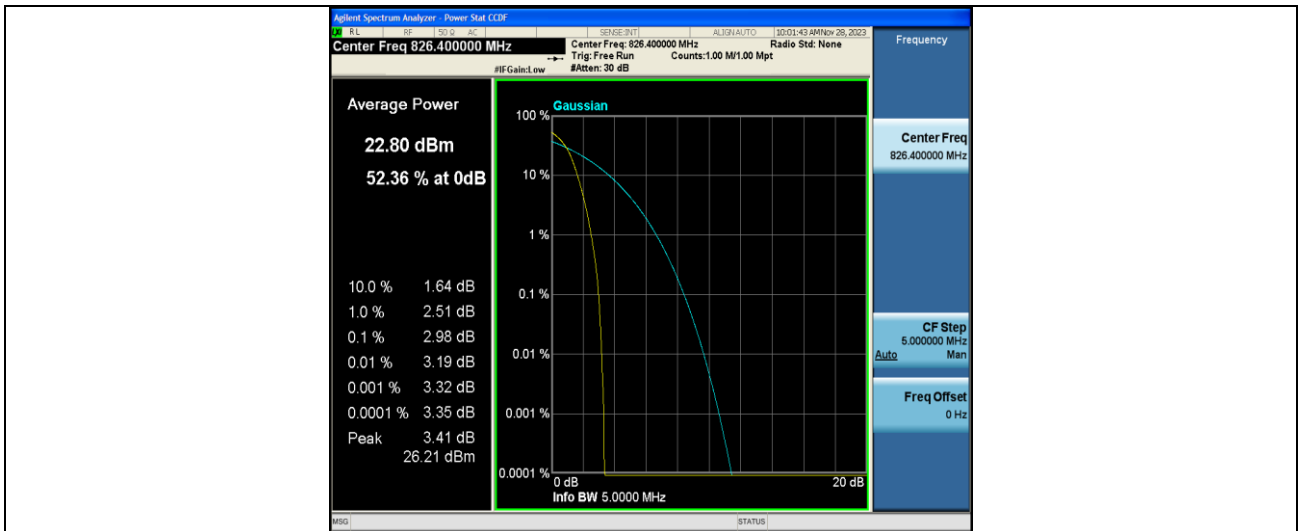

Band5-4182

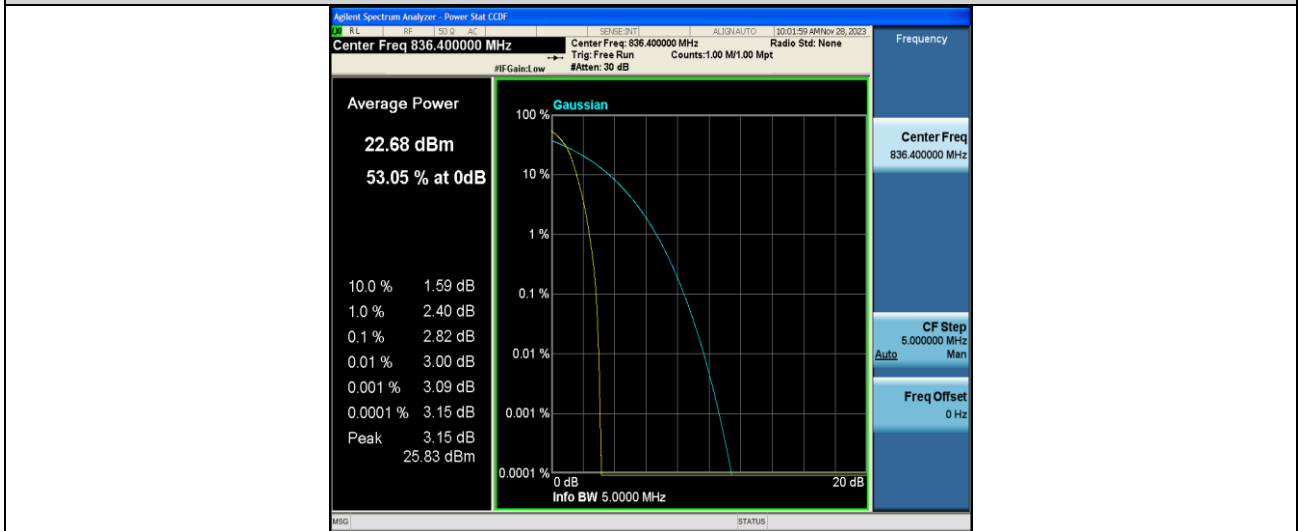

Band5-4233

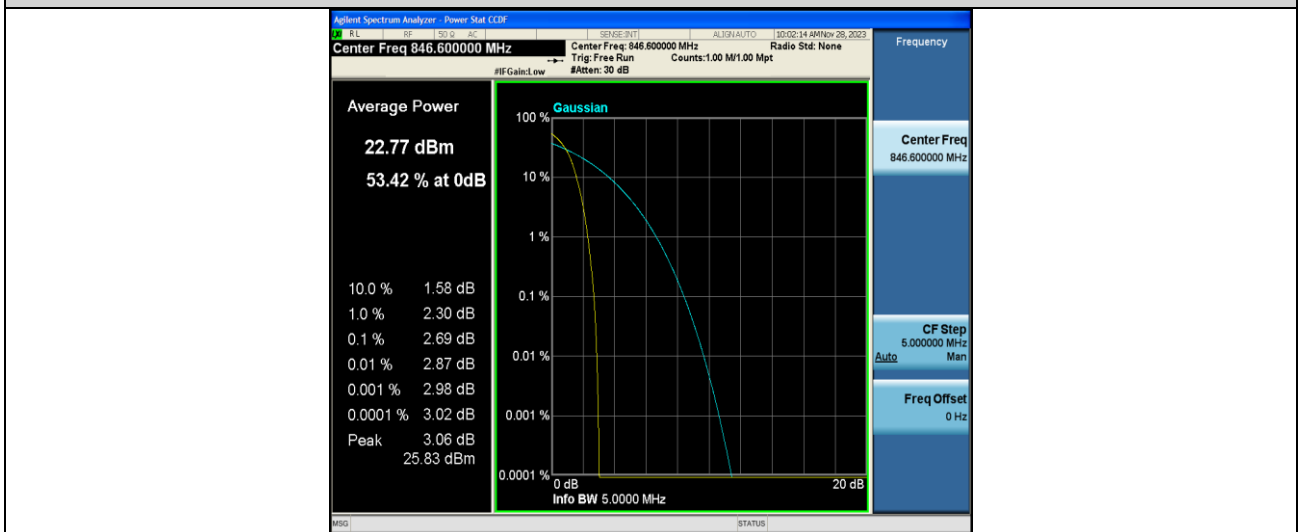

## 10. Frequency Stability

### Test limit:

The frequency stability of the transmitter shall be measured while varying the ambient temperatures and supply voltages over the ranges specified in §2.1055. The specific frequency stability limits are provided in the relevant rules section(s), see section 4.

### Test procedure:

Frequency Stability vs. Temperature: The equipment under test was connected to an external DC power supply and the RF output was connected to communication test set via feed-through attenuators. The EUT was placed inside the temperature chamber. The DC leads and RF output cable exited the chamber through an opening made for the purpose.

### Test setup:

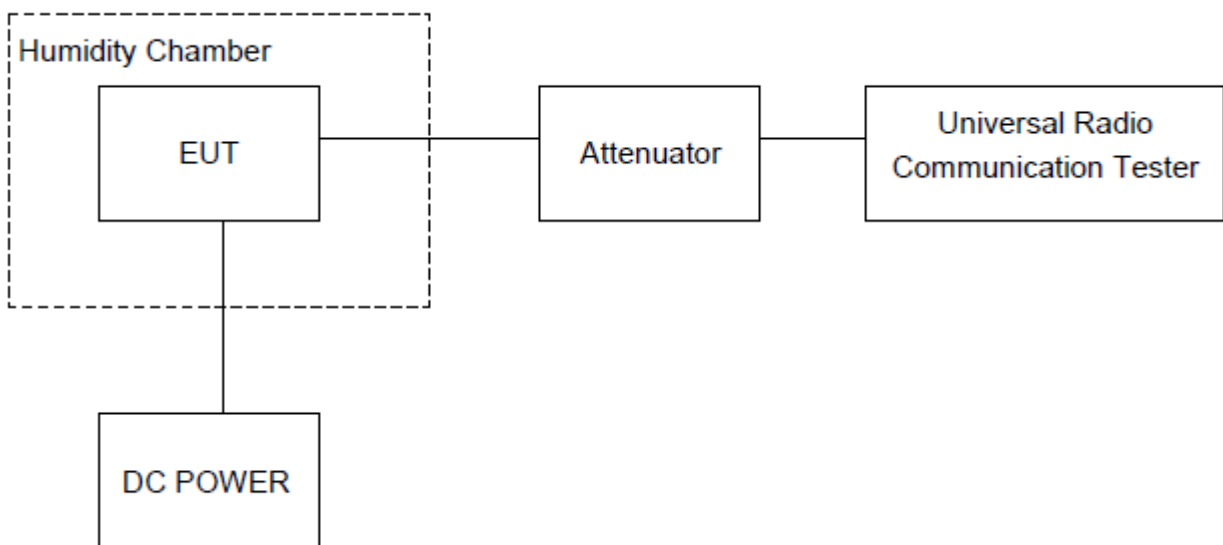

## 10.1. Measurement Result (Worst)

Voltage							
Band	Channel	Voltage (Vdc)	Temperature (°C)	Deviation (Hz)	Deviation (ppm)	Limit (ppm)	Verdict
Band2	9262	VL	NT	-6.77	-0.003655	±2.5	PASS
Band2	9262	VN	NT	-8.05	-0.004346	±2.5	PASS
Band2	9262	VH	NT	-8.14	-0.004394	±2.5	PASS
Band2	9400	VL	NT	-8.28	-0.004404	±2.5	PASS
Band2	9400	VN	NT	-5.64	-0.003000	±2.5	PASS
Band2	9400	VH	NT	-12.21	-0.006495	±2.5	PASS
Band2	9538	VL	NT	-13.35	-0.006998	±2.5	PASS
Band2	9538	VN	NT	-13.68	-0.007171	±2.5	PASS
Band2	9538	VH	NT	-7.87	-0.004126	±2.5	PASS
Band5	4132	VL	NT	-9.41	-0.011387	±2.5	PASS
Band5	4132	VN	NT	-11.78	-0.014255	±2.5	PASS
Band5	4132	VH	NT	-10.22	-0.012367	±2.5	PASS
Band5	4182	VL	NT	-8.69	-0.010390	±2.5	PASS
Band5	4182	VN	NT	-5.19	-0.006205	±2.5	PASS
Band5	4182	VH	NT	-6.69	-0.007999	±2.5	PASS
Band5	4233	VL	NT	-8.74	-0.010324	±2.5	PASS
Band5	4233	VN	NT	-10.52	-0.012426	±2.5	PASS
Band5	4233	VH	NT	-8.43	-0.009957	±2.5	PASS

Temperature							
Band	Channel	Voltage (Vdc)	Temperature (°C)	Deviation (Hz)	Deviation (ppm)	Limit (ppm)	Verdict
Band2	9262	NV	-30	-8.35	-0.004508	±2.5	PASS
Band2	9262	NV	-20	-7.86	-0.004243	±2.5	PASS
Band2	9262	NV	0	-11.66	-0.006295	±2.5	PASS
Band2	9262	NV	10	-8.95	-0.004832	±2.5	PASS
Band2	9262	NV	20	-10.36	-0.005593	±2.5	PASS
Band2	9400	NV	-30	-8.63	-0.004590	±2.5	PASS
Band2	9400	NV	-20	-9.34	-0.004968	±2.5	PASS
Band2	9400	NV	0	-8.38	-0.004457	±2.5	PASS
Band2	9400	NV	10	-12.92	-0.006872	±2.5	PASS
Band2	9400	NV	20	-11.17	-0.005941	±2.5	PASS
Band2	9538	NV	-30	-8.25	-0.004325	±2.5	PASS
Band2	9538	NV	-20	-8.44	-0.004424	±2.5	PASS
Band2	9538	NV	0	-6.98	-0.003659	±2.5	PASS
Band2	9538	NV	10	-9.05	-0.004744	±2.5	PASS
Band2	9538	NV	20	-9.84	-0.005158	±2.5	PASS
Band5	4132	NV	-30	-9.45	-0.011435	±2.5	PASS
Band5	4132	NV	-20	-11.77	-0.014242	±2.5	PASS
Band5	4132	NV	0	-9.97	-0.012064	±2.5	PASS
Band5	4132	NV	10	-9.19	-0.011121	±2.5	PASS
Band5	4132	NV	20	-12.33	-0.014920	±2.5	PASS
Band5	4182	NV	-30	-10.99	-0.013140	±2.5	PASS

Band5	4182	NV	-20	-10.21	-0.012207	±2.5	PASS
Band5	4182	NV	0	-9.75	-0.011657	±2.5	PASS
Band5	4182	NV	10	-12.19	-0.014574	±2.5	PASS
Band5	4182	NV	20	-13.72	-0.016404	±2.5	PASS
Band5	4233	NV	-30	-8.75	-0.010335	±2.5	PASS
Band5	4233	NV	-20	-13.87	-0.016383	±2.5	PASS
Band5	4233	NV	0	-12.36	-0.014600	±2.5	PASS
Band5	4233	NV	10	-3.87	-0.004571	±2.5	PASS
Band5	4233	NV	20	-6.11	-0.007217	±2.5	PASS

## **15 APPENDIX I -- TEST SETUP PHOTOGRAPH**

Refer to "Test Setup Photos".



## 16 APPENDIX II -- EUT PHOTOGRAPH

Refer to " External Photos" and "Internal Photos".

**\*\*\*\*\*THE END REPORT\*\*\*\*\***