

File Number **23/36401334\_M1**

## TEST REPORT

### FCC/ICES Test Report

#### Petitioner's Reference: PVHARDWARE SOLUTIONS

Customer Address: Av. de la Transacción Española, 32  
Parque Empresarial Omega, edificio A, 3ª planta  
28108 Alcobendas, Madrid

#### Equipment:

Brand:	PV HARDWARE	Model:	DBOX 5
S/N:	Not provided	Applus Id:	14113-00001

#### Result: complies

It has been tested and complies the standard specifications Applicable / s.  
See specifications applied on page 8.

#### Applicable Standards

#### FCC 47 CFR Part 15 Subpart B (October 2021)<sup>1</sup>

#### Emission standard/s:

<sup>1</sup>The latest modifications of the standard, published at the date of the tests reported in this document, have been considered

#### ICES-003 Issue 7 – 2020 (updated October 2020)

**Date of issue:** Bellaterra, June 26, 2023

**M1:** This report replaces and annuls the report with certificate number 23/36401334 dated 11-05-2023.

**Modifications performed:** According to customer, brand is modified (PV HARDWARE instead of DEEPTRACK) on pages 1, 3 and 8. It is responsibility of the petitioner to replace the previous version with this one.

EMC & Wireless Technical Manager  
Electrical and Electronics  
LGAI Technological Center S.A.

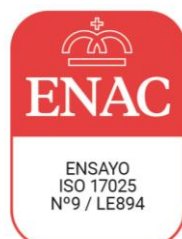

The results refer only and exclusively to the sample, product or material delivered for testing in "Received Material" section below. The equipment has been tested under conditions stipulated by standard(s) quoted in this document.  
This document will not be reproduced otherwise than in full.  
This is the first page of the document, which consists of 20 pages.

Tests marked with \* are not covered by ENAC accreditation

**INDEX**

- 1. EQUIPMENT RECEIVED AND TESTED ..... 3**
  - 1.1. TEST CONFIGURATION ..... 4
  - 1.2. AUXILIARY AND CONTROL EQUIPMENT ..... 4
  - 1.3. INPUT/OUTPUT WIRES ..... 4
  - 1.4. MODIFICATION PERFORMED ..... 4
  
- 2. APPLICABLE STANDARDS ..... 5**
  - 2.1. TEST APPLICABLE STANDARDS ..... 5
    - 2.1.1. Acceptance criteria for the test ..... 5
    - 2.1.2. Test facilities ID ..... 5
    - 2.1.3. Competences and Guarantees ..... 5
    - 2.1.4. Measuring uncertainties ..... 6
  - 2.2. USED EQUIPMENT ..... 7
  - 2.3. ENVIRONMENTAL CONDITIONS ..... 7
  
- 3. RESULT ..... 8**
  
- 4. ANNEXES ..... 9**
  - 4.1 TEST RESULTS ..... 9
    - 4.1.1 Radio-frequency radiated emissions ..... 9
  - 4.2. TEST SETUP CONFIGURATION ..... 18
  - 4.3. IDENTIFICATION PICTURES ..... 19

## 1. EQUIPMENT RECEIVED AND TESTED

### EQUIPMENT SPECIFICATIONS:

<b>Brand:</b>	PV HARDWARE	<b>Model:</b>	DBOX 5
<b>s/n:</b>	Not provided	<b>Power Supply Range:</b>	Internal battery (24 VDC)
<b>HW version:</b>	DB-DB5-WL	<b>FW version:</b>	5.X.X.X
<b>Maximum internal frequency:</b>	927.8 MHz		

### Product description:

*(Information declared by the manufacturer, Applus + is not responsible)*

*The DBox 5 controls the DC motor of the tracker directly from the box and communicates with the network plant controller through LoRa protocol to obtain maximum power. The device also monitors the actual tilt position of the tracker thanks to the inclinometer provided, which ensures and improves solar tracking.*

### RF FEATURES:

LoRa Module	
Radio chipset	SX1262
Brand	MURATA
Module model	LBAA0QB1SJ-296
Peak gain antenna internal	0.7 dBi
FCC ID	VPYLBAA0QB1SJ
ISED ID	772C-LBAA0QB1SJ

<b>Test product reception:</b>	13/04/2023
<b>Test initial date:</b>	13/04/2023
<b>Test final date:</b>	13/04/2023

### **1.1. Test configuration**

<b>Power Supply:</b>	Internal battery (24 VDC) but externally powered at 36 VDC.
<b>Set-up:</b>	Table-top The device under test is supplied at 36 VDC (limited at 1 A) and its I/O ports are charged as intended. The DC motor is not set to rotate during the testing.
<b>Test exercise:</b>	
<b>Equipment size:</b>	265 mm x 165 mm x 125 mm

---

### **1.2. Auxiliary and control equipment**

- The equipment under test does not have any auxiliary or control equipment.
- 

### **1.3. Input/output wires**

- DC power supply cable, shorter than 3 m.
  - DC motor output cable, shorter than 3 m.
- 

### **1.4. Modification performed**

No modifications were performed.

---

## 2. APPLICABLE STANDARDS

### 2.1. TEST APPLICABLE STANDARDS

**Standard: ANSI C63.4:2014 and ICES-003 issue 7**

**Basic standard: ANSI C63.4:2014**

Radio-frequency radiated emissions (30 MHz – 6 GHz)<sup>1</sup> : FCC Part 15.109, ICES-003 Issue 7(3.2.2)  
<sup>1</sup>Upper limit according to the fifth harmonic of the maximum internal frequency declared by the manufacturer or to 40 GHz, whichever is lower.

**Basic standard: ANSI C63.4:2014**

Power line conducted emissions (150 kHz – 30 MHz): FCC Part 15.107, ICES-003 Issue 7(3.2.1)

**Note:** The device is supplied by internal battery (36VDC). Therefore, this test is not applicable.

#### 2.1.1. Acceptance criteria for the test

According to standard **FCC 47 CFR Part 15 Subpart B and ICES-003 Issue 7**

#### 2.1.2. Test facilities ID

FCC Test Firm Registration Number:	507478
ISED Assigned Code:	5766A

#### 2.1.3. Competences and Guarantees

LGAI Technological Center, S.A. is a testing laboratory accredited by the National Accreditation Body (ENAC -Entidad Nacional de Acreditación), to perform the tests indicated in the Certificate No. 9/LE894. In order to assure the traceability to other national and international laboratories, Applus+ Laboratories has a calibration and maintenance program for its measurement equipment.

Applus+ Laboratories guarantees the reliability of the data presented in this report, which is the result of the measurements and the tests performed to the item under test on the date and under the conditions stated on the report and, it is based on the knowledge and technical facilities available at Applus+ Laboratories at the time of performance of the test.

Applus+ Laboratories is liable to the client for the maintenance of the confidentiality of all information related to the item under test and the results of the test. The results presented in this Test Report apply only to the particular item under test established in this document.

**IMPORTANT:** No parts of this report may be reproduced or quoted out of context, in any form or by any means, except in full, without the previous written permission of Applus+ Laboratories.

#### General conditions:

1. This report is only referred to the item that has undergone the test.
2. This report does not constitute or imply on its own an approval of the product by the Certification Bodies or competent Authorities.
3. This document is only valid if complete; no partial reproduction can be made without previous written permission of Applus+ Laboratories.
4. This test report cannot be used partially or in full for publicity and/or promotional purposes without previous written permission of Applus+ Laboratories and the Accreditation Bodies.

#### **2.1.4. Measuring uncertainties**

Radio-frequency radiated emissions 30 MHz - 1 GHz:	$\pm 5.2$ dB
Radio-frequency radiated emissions 1 GHz - 6 GHz:	$\pm 5.2$ dB

---

Expanded uncertainty measurement is obtained multiplying the typical uncertainty measurement with a coverage factor  $k=2$ , which corresponds to a confidence level of 95% for a normal distribution.

## 2.2. Used Equipment

RADIO-FREQUENCY RADIATED EMISSIONS (SAC2)					
EQUIPMENT	BRAND	MODEL	NUMBER	LAST CALIBRATION	NEXT CALIBRATION
EMI RECEIVER	R&S	ESW 26	1041791	19/12/2022	19/12/2023
TRILOG ANTENNA	SCHWARZBECK	VULB 9164	1042740	08/11/2022	08/11/2023
HORN ANTENNA	EMCO	3115	05-ER-182	04/11/2022	04/11/2023
ATENUADOR 3 DB	HUBER/SUHNER	6803.17.B	1042020	01/08/2022	01/08/2023
CABLE	HUBER/SUHNER	SF103/11N/16N/4000MM	1041909	10/02/2023	10/02/2024
CABLE	HUBER/SUHNER	SF126E	1042729	23/08/2022	23/08/2023
RF CABLE (WALL PANEL),	--	--	104572	01/08/2022	01/08/2023
SEMIANECHOIC CHAMBER SAC2	EUROSHIELD	TC2	104563	17/09/2021	17/09/2023
TEST SOFTWARE	ROHDE & SCHWARZ	EMC32 v.10.50.00	104624		
AUTOMATIC ANTENNA MAST	MATURO		1042591		
MAST-TABLE CONTROLLER	MATURO	NCD/052/8931211	1042758		

## 2.3. Environmental conditions

See results sheets

---

### 3. RESULT

PRODUCT:			
<b>Brand:</b>	PV HARDWARE	<b>Model:</b>	DBOX 5
<b>S/N:</b>	Not provided	<b>Internal Id:</b>	14113-00001
<b>Class:</b>	B		
TESTING	RESULTS	NOTES	
Radio-frequency radiated emissions. (FCC Part 15.109, ICES-003 Issue 7 (3.2.2))	Pass	Note: 4	
<p>The criteria to give conformity in those cases where it is not implicit in the standard or specification will be, for EMC emissions tests, a non-simple binary decision rule will be followed with a safety zone equal to the value of the uncertainty (<math>w = U</math>).</p> <p>In this case, the upper limit of the value of the probability of false acceptance, according to ILAC G8, is 2.5% and the criteria notes are:</p> <p><b>1:</b> The measured results are above the upper limit, even considering the uncertainty interval.</p> <p><b>2:</b> The measured results are above the specified limits, but within the uncertainty interval. It is therefore not possible to state compliance based on the 95% level of confidence. However, the results indicate that non-compliance is more probable than compliance</p> <p><b>3:</b> The measured results are below the specified limits, but within the uncertainty interval. It is therefore not possible to state compliance based on the 95% level of confidence. However, the results indicate that compliance is more probable than non-compliance</p> <p><b>4:</b> The measured results are within the limits, including the uncertainty interval.</p>			

#### Service Quality Assurance

**Applus+**, guarantees that this work has been made in accordance with our Quality and Sustainability System, fulfilling the contractual conditions and legal norms.

Within our improvement program we would be grateful if you would send us any commentary that you consider opportune, to the person in charge who signs this document, or to the Quality Manager of Applus+, in the following e-mail address:

[satisfaccion.cliente@applus.com](mailto:satisfaccion.cliente@applus.com)



## 4. ANNEXES

### 4.1 Test Results

#### 4.1.1 Radio-frequency radiated emissions

##### Test Procedures:

The test site, 3 or 10 m semi-anechoic chamber, has met the requirement of NSA tolerance 4 dB according to the standards: ANSI C63.4-2014

The radiated measurements are performed in vertical and horizontal plane in the frequency range from 30 MHz to 1 GHz in semi-anechoic chambers. The receiving antennas are conform to specifications ANSI C63. These antennas can be moved over the height range between 1.0 m and 4.0 m in order to search for maximum field strength emitted from EUT. The measurement distances between EUT and receiving antennas are indicated in the test setups for the various frequency ranges. For each measurement, the EUT is rotated in all three axes until the maximum field strength is received.

##### EMI Receiver configuration:

During the radiated emission test, the EMI receiver was set with the following configurations:

Frequency band (MHz)	Function	Resolution Bandwidth	Video Bandwidth
30 to 1000	QP	120 kHz	300 kHz
Above 1000	Peak	1 MHz	3 MHz
	Average	1 MHz	10 Hz

##### Pre-measurement

- The turntable rotates from 0° to 315° using 45° steps
- The antenna is polarized vertical and horizontal
- The antenna height changes from 1 m to 4 m
- At each turntable position, antenna polarization and height the receiver finds the maximum of all emissions

##### Final measurement

- The final measurement is performed for at least six highest peaks according to the requirements of the ANSI C63.4
- Based on antenna and turntable positions at which the peak values are measured the software maximize the peaks by changing turntable position 360 ° and antenna height between 1 and 4 m
- The final measurement is done with quasi-peak detector (as described in ANSI C63.4) for 30MHz to 1GHz emissions test
- The final measurement is done in the position (azimuth, height and antenna polarization) causing the highest emissions with Peak and RMS detector (as described in ANSI C63.4) for 1GHz to 18GHz test
- Final levels, frequency, measuring time, bandwidth, antenna height, antenna polarization, turntable angle, correction factors, margin to the limit and limit are recorded. A plot with the graph of the premeasurement with marked maximum final results and the limit is shown

##### Correction Factor:

Emission Level = Read Level + Corrections (Ant.Factor + Cable Loss – Ampli.Gain (if applies) + Attenuator (if applies))

**Limits:**

According to FCC Part 15.109:

- Limits of Radiated Emission Measurement (Below 1000 MHz)

Frequency (MHz)	Class B (dB $\mu$ V/m) (at 3 m)
	QuasiPeak
30 – 88	40
88 – 216	43.5
216 – 960	46
960 – 1000	54

Frequency (MHz)	Class A (dB $\mu$ V/m) (at 10 m)
	QuasiPeak
30 – 88	39
88 – 216	43.5
216 – 960	46.4
960 – 1000	49.5

- Limits of Radiated Emission Measurement (Above 1000 MHz)

Frequency (MHz)	Class B (dB $\mu$ V/m) (at 3 m)	
	Peak	Average
Above 1000	74	54

Frequency (MHz)	Class A (dB $\mu$ V/m) (at 10 m)	
	Peak	Average
Above 1000	69.5	49.5

According to ICES-003 Issue 7 (3.2.2):

- Limits of Radiated Emission Measurement (Below 1000 MHz)

Frequency range (MHz)	Class A (3 m) Quasi-peak (dB $\mu$ V/m)	Class A (10 m) Quasi-peak (dB $\mu$ V/m)	Class B (3 m) Quasi-peak (dB $\mu$ V/m)	Class B (10 m) Quasi-peak (dB $\mu$ V/m)
30 – 88	50.0	40.0	40.0	30.0
88 – 216	54.0	43.5	43.5	33.1
216 – 230	56.9	46.4	46.0	35.6
230 – 960	57.0	47.0	47.0	37.0
960 – 1000	60.0	49.5	54.0	43.5

- Limits of Radiated Emission Measurement (Above 1000 MHz)

Frequency range (GHz)	Class A (3 m) Average dB( $\mu$ V/m)	Class A (3 m) Peak dB( $\mu$ V/m)	Class B (3 m) Average dB( $\mu$ V/m)	Class B (3 m) Peak dB( $\mu$ V/m)
1 - 6	60	80	54	74

If using a different measurement distance, the measured levels shall be extrapolated using a factor of 20 dB per decade of distance. The measurement distance shall place the measurement antenna in the far field of the ITE or digital apparatus under test.

**Test Setup (depending on the EUT arrangement):**

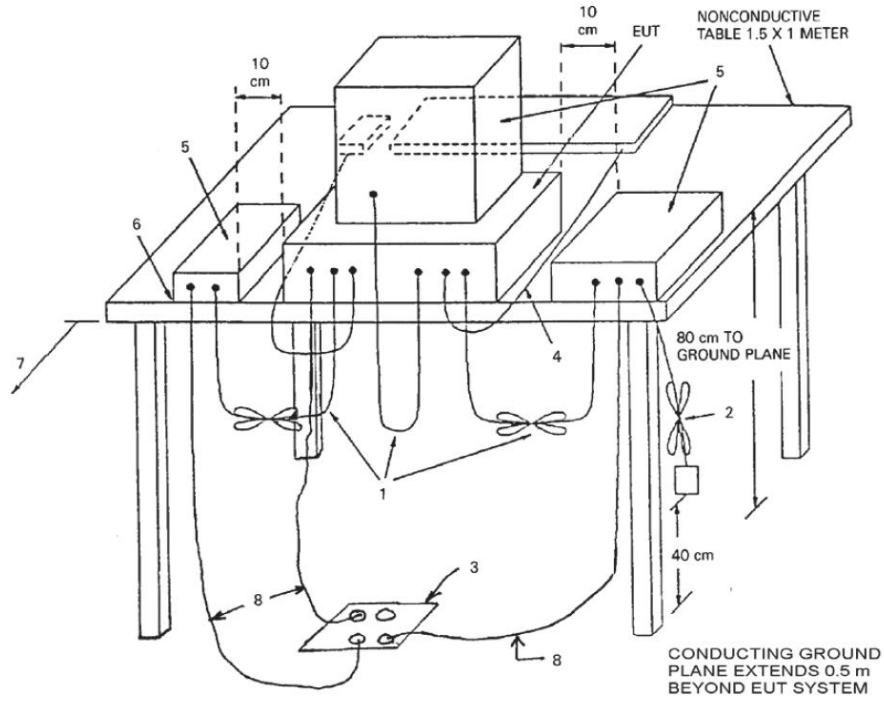

**Radio-frequency radiated emissions of tabletop equipment.**

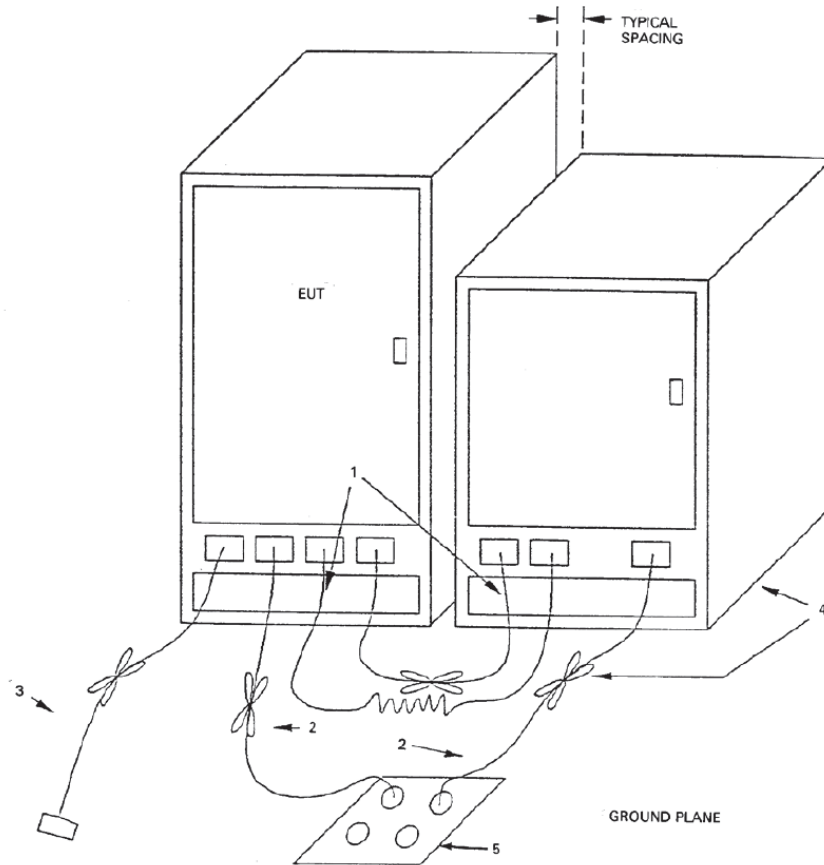

**Radio-frequency radiated emissions of floor-standing equipment.**

**Test Configuration (depending on the EUT arrangement):**

- **For radiated emissions from 30 MHz to 1000 MHz:**

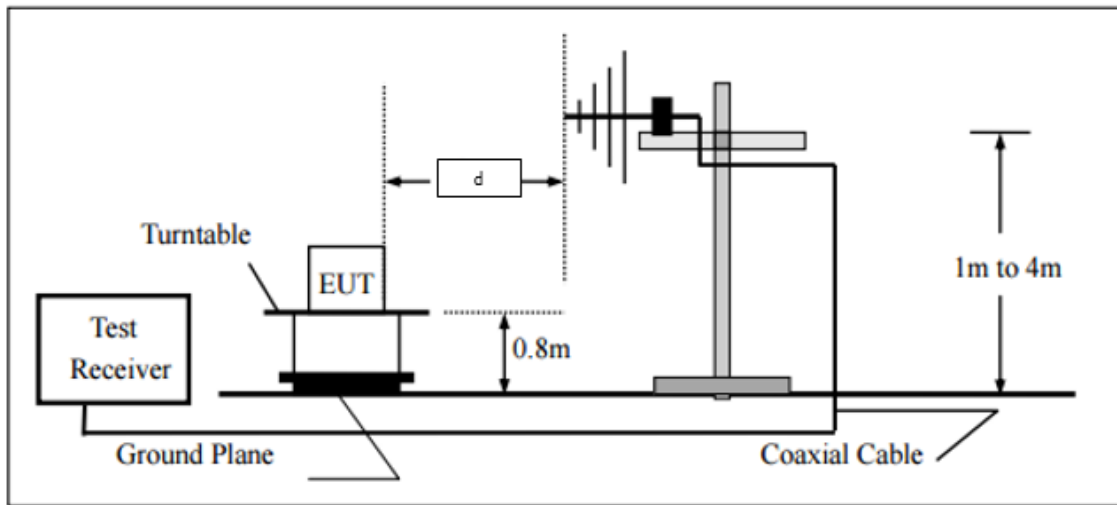

**Radio-frequency radiated emissions of tabletop equipment.**

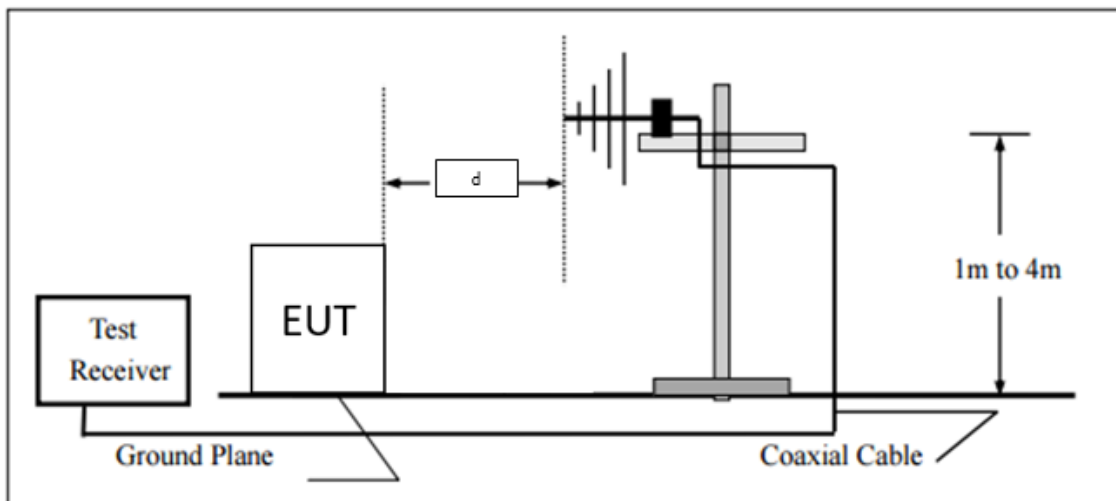

**Radio-frequency radiated emissions of floor-standing equipment.**

Distance "d" depends on test chamber.

- For radiated emissions above 1000 MHz:

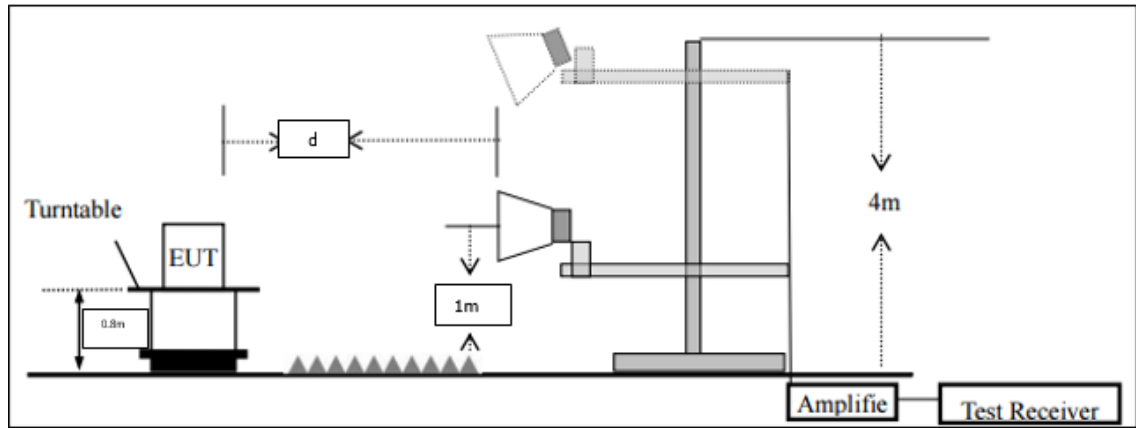

**Radio-frequency radiated emissions of tabletop equipment.**

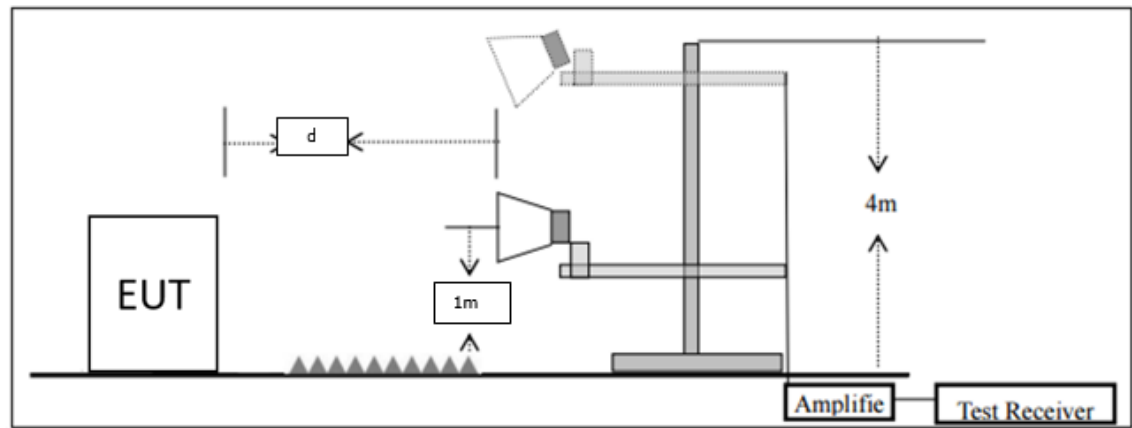

**Radio-frequency radiated emissions of floor-standing equipment.**

Distance "d" depends on test chamber.

RADIO-FREQUENCY RADIATED EMISSIONS (below 1 GHz)														
<b>Technician:</b> Ignacio Serrano / D. Sibajas / O.Merchan			<b>Frequency range:</b> 30 MHz – 1 GHz											
<b>Test date:</b> 13/04/2023			<input checked="" type="checkbox"/> with supervision: N/A											
<b>Basic standard:</b> ANSI C63.4:2014														
<table border="1" style="width: 100%;"> <tr> <td><b>Temperature:</b></td> <td>20.2</td> <td>°C</td> </tr> <tr> <td><b>Humidity:</b></td> <td>29.4</td> <td>%</td> </tr> <tr> <td><b>Atm. Pressure:</b></td> <td>993.4</td> <td>hPa</td> </tr> </table>						<b>Temperature:</b>	20.2	°C	<b>Humidity:</b>	29.4	%	<b>Atm. Pressure:</b>	993.4	hPa
<b>Temperature:</b>	20.2	°C												
<b>Humidity:</b>	29.4	%												
<b>Atm. Pressure:</b>	993.4	hPa												
EUT:	Class	Test Area	Distance	PreScan	Evaluation									
Table-top	B	SAC2	3 m (30 MHz – 1 GHz)	8 faces (45° step)	Individual									
<b>RESULTS:</b> Pass														
Identification	Emissions		Main emission source and type											
DUT: Device under test BB: Broadband NB: Narrowband SPU: Spurs QP: Quasi-peak U: Uncertainty	QP < Limit - U		DUT, NB											
<b>Comments</b>														
<i>The EUT is charged externally with the FA (Applus) 05 ER - 142, with 36V and limited to 1A.</i>														

**RADIO-FREQUENCY RADIATED EMISSIONS (below 1 GHz)**

**PRESCAN 30 MHz – 1 GHz**

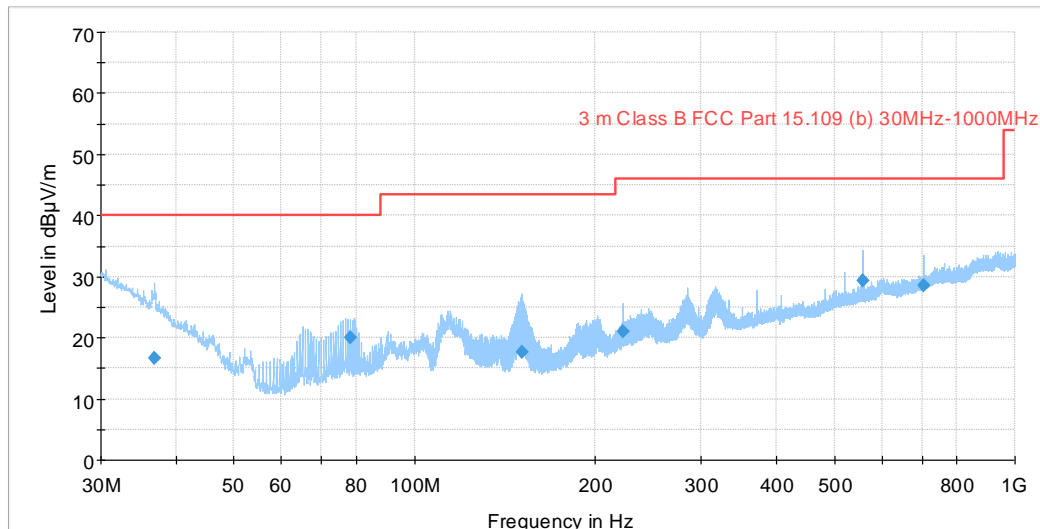

- Preview Result 1-PK+
- \* Critical\_Freqs AVG
- 3 m Class B FCC Part 15.109 (b) 30MHz-1000MHz
- ◆ Final\_Result QPK

**FINAL MEASUREMENTS**

Frequency (MHz)	QuasiPeak (dBµV/m)	Limit (dBµV/m)	Margin (dB)	Height (cm)	Pol	Azimuth (deg)	Corr. (dB/m)
36.840	16.56	40.00	23.44	104.0	V	283.0	22.0
78.060	20.04	40.00	19.96	105.0	V	223.0	12.5
150.630	17.68	43.50	25.82	110.0	V	235.0	13.0
222.750	20.96	46.00	25.04	197.0	H	139.0	16.8
556.860	29.38	46.00	16.62	365.0	V	342.0	24.6
705.390	28.58	46.00	17.42	167.0	H	191.0	26.3

**Comments:**

*Emission Level = Read Level + Corrections (Ant.Factor + Cable Loss + Attenuator)*

Note: radiated emissions from 30 MHz to 1 GHz has been done at 3 meters of distance from EUT to antenna. The limits has been modified according to the standard using the following formula:  $L_2 = L_1 + 20\log(d_1/d_2)$ , where:

L<sub>2</sub>: New limit

L<sub>1</sub>: Limit at 10 meters

d<sub>1</sub>: 10 meters (standard distance)

d<sub>2</sub>: 3 meters (new measurement distance)

RADIO-FREQUENCY RADIATED EMISSIONS (above 1 GHz)														
<b>Technician:</b> Ignacio Serrano / D. Sibajas		<b>Frequency range:</b> 1 GHz – 6 GHz												
<b>Test date:</b> 13/04/2023		<input type="checkbox"/> with supervision: N/A												
<b>Basic standard:</b> ANSI C63.4:2014														
<table border="1" style="width: 100%;"> <tr> <td><b>Temperature:</b></td> <td>20.2</td> <td>°C</td> </tr> <tr> <td><b>Humidity:</b></td> <td>29.4</td> <td>%</td> </tr> <tr> <td><b>Atm. Pressure:</b></td> <td>993.4</td> <td>hPa</td> </tr> </table>						<b>Temperature:</b>	20.2	°C	<b>Humidity:</b>	29.4	%	<b>Atm. Pressure:</b>	993.4	hPa
<b>Temperature:</b>	20.2	°C												
<b>Humidity:</b>	29.4	%												
<b>Atm. Pressure:</b>	993.4	hPa												
EUT:	Class	Test Area	Distance	PreScan	Evaluation									
Table-top	B	SAC2	3 m (1 GHz – 6 GHz)	8 faces (45° step)	Individual									
<b>RESULTS:</b> Pass														
Identification	Emissions	Main emission source and type												
DUT: Device under test BB: Broadband NB: Narrowband SPU: Spurs QP: Quasi-peak U: Uncertainty	AVG < Limit – U PK < Limit – U	DUT, NB												
Comments														



**RADIO-FREQUENCY RADIATED EMISSIONS (above 1 GHz)**

**PRESCAN 1 GHz – 6 GHz**

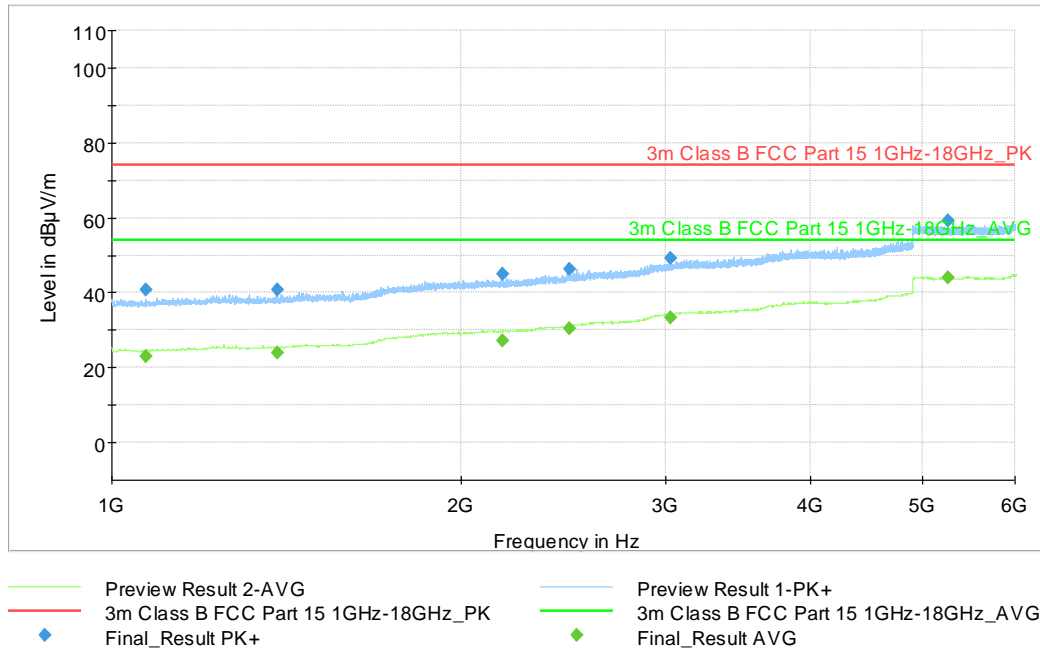

**FINAL MEASUREMENTS**

Frequency (MHz)	MaxPeak (dBµV/m)	Limit (dBµV/m)	Margin (dB)	Average (dBµV/m)	Limit (dBµV/m)	Margin (dB)	Height (cm)	Pol	Azimuth (deg)
1069.750	40.69	74.00	33.31	22.96	54.00	31.04	263.0	H	7.0
1388.250	40.80	74.00	33.20	24.06	54.00	29.94	304.0	H	147.0
2171.250	45.10	74.00	28.90	27.16	54.00	26.84	154.0	H	245.0
2478.250	46.28	74.00	27.72	30.32	54.00	23.68	292.0	H	146.0
3029.250	49.11	74.00	24.89	33.29	54.00	20.71	225.0	V	155.0
5247.750	59.15	74.00	14.85	44.17	54.00	9.83	285.0	V	34.0

**Comments:**

*Emission Level = Read Level + Corrections (Ant.Factor + Cable Loss + Attenuator)*

## 4.2. Test Setup Configuration

From file number: 23/36401334\_M1

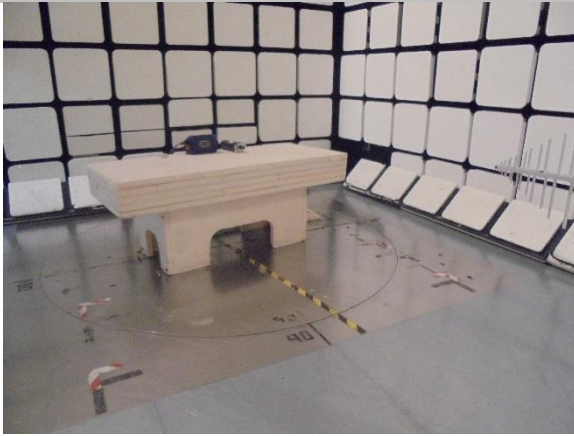

Radio-frequency radiated emissions 30 MHz to 1 GHz

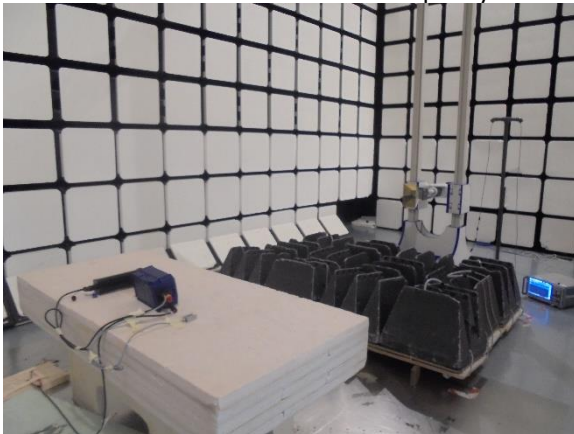

Radio-frequency radiated emissions 1 GHz to 6 GHz

### 4.3. Identification pictures

From file number: 23/36401334\_M1



Frontal view



Top view



Left view

Applus<sup>+</sup>  
laboratories

ID Submuestra: 14113-00001



Ciente: DEEPTRACK, S.L.U.

Código Oferta: YT-2212122ALF-1

Fecha Recepción: 13-04-2023

Marca Muestra: DEEPTRACK Modelo: DBOX 5

Nº de Serie:



AUX. Top view



AUX. Left view



AUX. Left view



AUX. Manufacturer Label



AUX. Frontal view



AUX. Top view



AUX. Frontal view



AUX. Top view