

SPECIFICATION FOR APPROVAL

1. MECHANICAL DIMENSION (UNIT:mm)

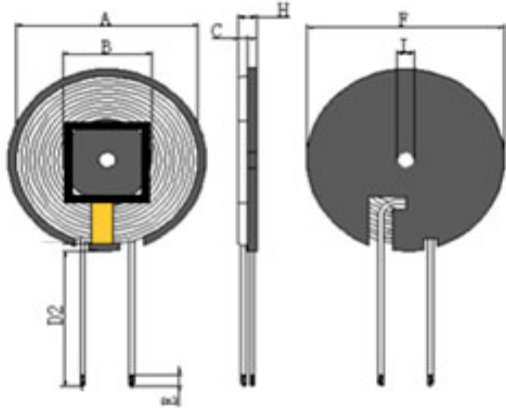

2. SCHEMATICS:

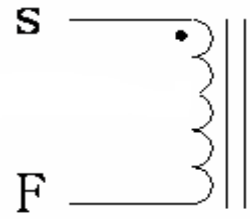

A	B	C	D2	E	F	I
50±1.0	20.5±0.5	1.2±0.2	15±3	3ref	50±1.0	5.0ref

3. WINDING:

STEP	START-FINISH	WIRE TYPE	TURNS	TAPE	REMARK
N1	S-F	∅0.08*105mm 2UEW	12TS (Ref)		

4. ELECTRICAL SPECIFICATION:

ITEM	L	DCR	IDC	Q值	HI-POT
TEST	S-F	S-F			
CON	100KHz, 0.25V	AT 25°C			
SPEC	10uH±10%	60mΩ Max			

5. BILF OF MATERIAL:

NO.	ITEM	MATERIAL SPECIFICATION	MANUFACTURER	SGS NO.
1	CORE	G50L N95	NANJINGJINNINGCO,LTD	
2	CORE		NANJINGJINNINGCO,LTD	
3	WIRE	∅0.08mm*105 2UEW	TAIYI CO.,LTD	
4	TUBE	10mm	LIANCHENG CO.,LTD	
5	EPOXY	9999	CUDAK CO.,LTD	

HRSW ELECTRONICS CO.,LTD	PART NO	
	TITLE	G50开槽15WAP2
DRAWN BY	CHECKED BY	APPROVED BY
谢超	何伟华	韦立红

SPECIFICATION FOR APPROVAL

CUSTOMER: _____

ROHS

CUSTOMER P/N: _____

TITLE: SMD INDUCTANCE

DATE: 2020/12/30

HRSW MODLE : 15W

REV. NO. : A0

PLEASE RETURN TO US COPY OF "SPECIFICATION FOR APPROVAL "WITH YOUR APPROVED

APPROVED <input type="checkbox"/>	REJECTED <input type="checkbox"/>	“ ✓ ”
CUSTOMER'S SIGNATURE _____		

REV	DATE	CHANGED CONTENTENTS &CHANGED REASONS	DRAWN	CHECKED	APPROVED
A0	2020/12/30	NEW RELEASE	谢超	何伟华	韦立红

鸿日升威科 技 有 限 公 司

HRSW ELECTRONICS CO.,LTD

ADD: 深圳市龙华新区观澜环观中路48号3栋1楼
1st Floor, Building 3, No. 48, Guanlan Huanguan Middle Road, Longhua New District,
Shenzhen
TEL: +86-755-23461055 FAX: +86-0755-28015170