

RF TEST REPORT

Applicant	Cognition Controls Co.
FCC ID	2BCO5CC301
Product	Smart Commercial Control
Brand	Cognition Controls
Model	CC-301
Report No.	R2312A1440-R3
Issue Date	March 4, 2024

TA Technology (Shanghai) Co., Ltd. tested the above equipment in accordance with the requirements in **FCC CFR47 Part 2 (2023)/ FCC CFR47 Part 27C (2023)**. The test results show that the equipment tested is capable of demonstrating compliance with the requirements as documented in this report.

Prepared by: Zhu Chentao

Approved by: Xu Kai

TA Technology (Shanghai) Co., Ltd.

Building 3, No.145, Jintang Rd, Pudong Shanghai, P.R.China

TEL: +86-021-50791141/2/3

FAX: +86-021-50791141/2/3-8000

TABLE OF CONTENT

1	Test Laboratory	4
1.1	Notes of the Test Report.....	4
1.2.	Test facility	4
1.3	Testing Location.....	4
2	General Description of Equipment under Test	5
2.1	Applicant and Manufacturer Information	5
2.2	General information	5
3	Applied Standards	7
4	Test Configuration	8
5	Test Case	9
5.1	Radiated Spurious Emission	9
6	Test Results	13
6.1	Radiated Spurious Emission	13
7	Main Test Instruments	20
	ANNEX A: The EUT Appearance	21
	ANNEX B: Test Setup Photos	22

Summary of Measurement Results

Number	Test Case	Clause in FCC rules	Verdict
1	Radiated Spurious Emission	2.1053 /27.53(h) /27.53(g) /27.53(f) /27.53(c)	PASS
Date of Testing: January 3, 2024 ~ February 5, 2024 Date of Sample Received: December 25, 2023			
Note: PASS: The EUT complies with the essential requirements in the standard. FAIL: The EUT does not comply with the essential requirements in the standard. All indications of Pass/Fail in this report are opinions expressed by TA Technology (Shanghai) Co., Ltd. based on interpretations and/or observations of test results. Measurement Uncertainties were not taken into account and are published for informational purposes only.			

Only Radiated Spurious Emission is tested for CC-301 in this report.

Other test items refer to the Module report (Report No.: R2004A0250-R3V3, FCC ID: XMR2020BG95M1).

1 Test Laboratory

1.1 Notes of the Test Report

This report shall not be reproduced in full or partial, without the written approval of **TA Technology (Shanghai) Co., Ltd.** The results documented in this report apply only to the tested sample, under the conditions and modes of operation as described herein. Measurement Uncertainties were not taken into account and are published for informational purposes only. This report is written to support regulatory compliance of the applicable standards stated above.

1.2. Test facility

FCC (Designation number: CN1179, Test Firm Registration Number: 446626)

TA Technology (Shanghai) Co., Ltd. has been listed on the US Federal Communications Commission list of test facilities recognized to perform measurements.

A2LA (Certificate Number: 3857.01)

TA Technology (Shanghai) Co., Ltd. has been listed by American Association for Laboratory Accreditation to perform measurement.

1.3 Testing Location

Company: TA Technology (Shanghai) Co., Ltd.

Address: Building 3, No.145, Jintang Rd, Pudong Shanghai, P.R.China

City: Shanghai

Post code: 201201

Country: P. R. China

Contact: Xu Kai

Telephone: +86-021-50791141/2/3

Fax: +86-021-50791141/2/3-8000

Website: <https://www.eurofins.com/electrical-and-electronics>

E-mail: Kain.Xu@cpt.eurofinscn.com

2 General Description of Equipment under Test

2.1 Applicant and Manufacturer Information

Applicant	Cognition Controls Co.
Applicant address	68 Harrison Ave. #605, Boston, MASSACHUSETTS, USA
Manufacturer	Cognition Controls Co.
Manufacturer address	68 Harrison Ave. #605, Boston, MASSACHUSETTS, USA

2.2 General information

EUT Description			
Model	CC-301		
SN	CCTHR3000073		
Hardware Version	V1		
Software Version	1.0.0		
Power Supply	External power supply		
Antenna Type	External Antenna		
Antenna Gain	LTE-M Band 4: 1.9 dBi LTE-M Band 12: 4.0 dBi LTE-M Band 13: 4.5 dBi LTE-M Band 66: 2.0 dBi LTE-M Band 85: 4.0 dBi		
Test Mode(s)	LTE-M Band 4/12/13/66/85;		
Test Modulation	(LTE-M) QPSK, 16QAM;		
LTE-M Category	M1		
Rated Power Supply Voltage	24V		
Operating Voltage	Minimum: 16V Maximum: 32V		
Operating Temperature	Lowest: 5°C Highest: +60°C		
Testing Temperature	Lowest: -30°C Highest: +50°C		
Frequency Range(s)	Mode	Tx (MHz)	Rx (MHz)
	LTE-M Band 4	1710 ~ 1755	2110 ~ 2155
	LTE-M Band 12	699 ~ 716	729 ~ 746
	LTE-M Band 13	777 ~ 787	746 ~ 756
	LTE-M Band 66	1710 ~ 1780	2110 ~ 2180
	LTE-M Band 85	698 ~ 716	728 ~ 746

EUT Accessory	
Battery	Manufacturer: NuEnergy (Backup Battery) Model: NUE11SYY902535X78A DC 3.7V, 780mAh
Auxiliary test equipment	
Adapter	Manufacturer: Multiple, Not supplied with sale of thermostat. It is part of the HVAC unit. Model: For testing I will provide PWS-2440
Note: 1. The EUT is sent from the applicant to TA and the information of the EUT is declared by the applicant.	

3 Applied Standards

According to the specifications of the manufacturer, it must comply with the requirements of the following standards:

Test standards:

FCC CFR47 Part 27C (2023)

FCC CFR47 Part 2 (2023)

Reference standard:

ANSI C63.26-2015

KDB 971168 D01 Power Meas License Digital Systems v03r01

4 Test Configuration

Radiated measurements are performed by rotating the EUT in three different orthogonal test planes. EUT stand-up position (Z axis), lie-down position (X, Y axis). Receiver antenna polarization (horizontal and vertical), the worst emission was found in position (Z axis, vertical polarization) and the worst case was recorded.

All mode and data rates and positions and RB size and modulations were investigated. Subsequently, only the worst case emissions are reported.

The following testing in LTE-M is set based on the maximum RF Output Power.

The following testing in different Bandwidth is set to detail in the following table:

Test modes are chosen to be reported as the worst case configuration below for LTE-M Band 4/12/13/66/85:

Test items	Modes	Bandwidth (MHz)						Modulation		RB			Test Channel		
		1.4	3	5	10	15	20	QPSK	16QAM	1	50%	100%	L	M	H
Radiated Spurious Emission	LTE 4	O	-	O	-	-	O	O	-	O	-	-	-	O	-
	LTE 12	O	-	O	O	-	-	O	-	O	-	-	-	O	-
	LTE 13	-	-	O	O	-	-	O	-	O	-	-	-	O	-
	LTE 66	O	-	O	-	-	O	O	-	O	-	-	-	O	-
	LTE 85	-	-	O	O	-	-	O	-	O	-	-	-	O	-
Note	1. The mark "O" means that this configuration is chosen for testing. 2. The mark "-" means that this configuration is not testing.														

5 Test Case

5.1 Radiated Spurious Emission

Ambient condition

Temperature	Relative humidity	Pressure
15°C ~ 35°C	20% ~ 80%	86 kPa ~ 106 kPa

Method of Measurement

1. The testing follows FCC KDB 971168 D01 v03r01 Section 5.8 and ANSI C63.26-2015.
2. Below 1GHz: The EUT is placed on a turntable 0.8 meters above the ground in the chamber, 3 meter away from the antenna. The maximal emission value is acquired by adjusting the antenna height, polarisation and turntable azimuth. Normally, the height range of antenna is 1 m to 4 m, the azimuth range of turntable is 0° to 360°, and the receive antenna has two polarizations Vertical (V) and Horizontal (H). Above 1GHz: (Note: the FCC's permission to use 1.5m as an alternative per TCBC Conf call of Dec. 2, 2014.) The EUT is placed on a turntable 1.5 meters above the ground in the chamber, 3 meter away from the antenna. The maximal emission value is acquired by adjusting the antenna height, polarisation and turntable azimuth. Normally, the height range of antenna is 1 m to 4 m, the azimuth range of turntable is 0° to 360°, and the receive antenna has two polarizations Vertical (V) and Horizontal (H).
3. A loop antenna, A log-periodic antenna or horn antenna shall be substituted in place of the EUT. The log-periodic antenna will be driven by a signal generator and the level will be adjusted till the same power value on the spectrum analyzer or receiver. The level of the spurious emissions can be calculated through the level of the signal generator, cable loss, the gain of the substitution antenna and the reading of the spectrum analyzer or receiver.
4. The EUT is then put into continuously transmitting mode at its maximum power level during the test. Set Test Receiver or Spectrum RBW=100kHz, VBW=300kHz for 30MHz to 1GHz and RBW=1MHz, VBW=3MHz for above 1GHz, and the maximum value of the receiver should be recorded as (Pr).
5. The EUT shall be replaced by a substitution antenna. In the chamber, an substitution antenna for the frequency band of interest is placed at the reference point of the chamber. An RF Signal source for the frequency band of interest is connected to the substitution antenna with a cable that has been constructed to not interfere with the radiation pattern of the antenna. A power (PMea) is applied to the input of the substitution antenna, and adjust the level of the signal generator output until the value of the receiver reach the previously recorded (Pr). The power of signal source (PMea) is recorded. The test should be performed by rotating the test item and adjusting the receiving antenna polarization.
6. A amplifier should be connected to the Signal Source output port. And the cable should be connect between the Amplifier and the Substitution Antenna. The cable loss (Pcl) ,the Substitution Antenna Gain (Ga) and the Amplifier Gain (PAg) should be recorded after test.
7. The measurement results are obtained as described below:

Power(EIRP)=PMea- PAg - Pcl + Ga

The measurement results are amend as described below:

Power(EIRP)=P_{Mea}- P_{cl} + G_a

8. This value is EIRP since the measurement is calibrated using an antenna of known gain (2.15 dB) and known input power. ERP can be calculated from EIRP by subtracting the gain of the dipole, ERP = EIRP-2.15dB.

The modulation mode and RB allocation refer to section 5.1, using the maximum output power configuration.

Test setup

9KHz~ 30MHz

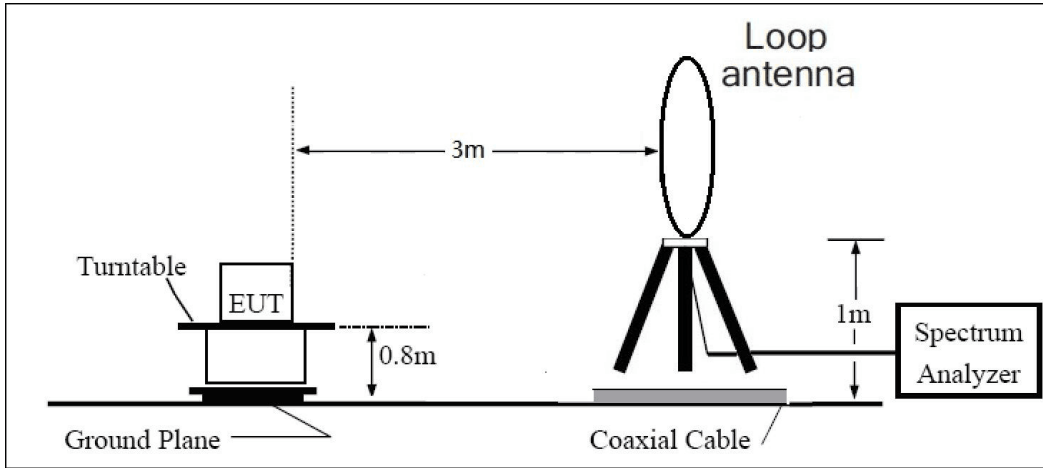

30MHz~ 1GHz

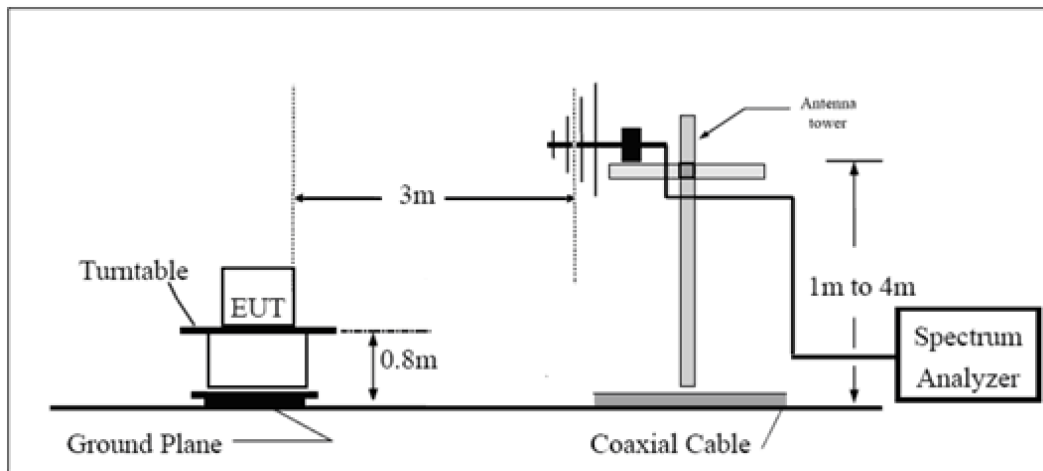

Above 1GHz

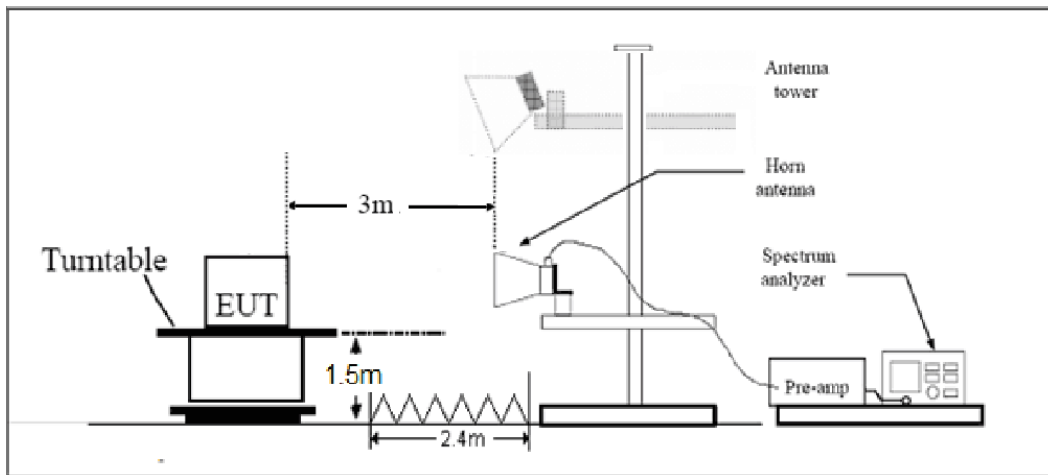

Note: Area side:2.4mX3.6m

Limits

Rule Part 27.53(h) specifies that “for operations in the 1695-1710 MHz, 1710-1755 MHz, 1755-1780 MHz, 1915-1920 MHz, 1995-2000 MHz, 2000-2020 MHz, 2110-2155 MHz, 2155-2180 MHz, and 2180-2200 bands, the power of any emission outside a licensee's frequency block shall be attenuated below the transmitter power (P) in watts by at least $43 + 10 \log_{10}(P)$ dB.”

Rule Part 27.53 (g) For operations in the 600 MHz band and the 698-746 MHz band, the power of any emission outside a licensee's frequency band(s) of operation shall be attenuated below the transmitter power (P) within the licensed band(s) of operation, measured in watts, by at least $43 + 10 \log(P)$ dB. Compliance with this provision is based on the use of measurement instrumentation employing a resolution bandwidth of 100 kilohertz or greater. However, in the 100 kilohertz bands immediately outside and adjacent to a licensee's frequency block, a resolution bandwidth of at least 30 kHz may be employed.

Rule Part 27.53(f) For operations in the 746-758 MHz, 775-788 MHz, and 805-806 MHz bands, emissions in the band 1559-1610 MHz shall be limited to -70 dBW/MHz equivalent isotropically radiated power (EIRP) for wideband signals, and -80 dBW EIRP for discrete emissions of less than 700 Hz bandwidth. For the purpose of equipment authorization, a transmitter shall be tested with an antenna that is representative of the type that will be used with the equipment in normal operation.

Part 27.53 (c) For operations in the 746-758 MHz band and the 776-788 MHz band, the power of any emission outside the licensee's frequency band(s) of operation shall be attenuated below the transmitter power (P) within the licensed band(s) of operation, measured in watts, in accordance with the following:

- (1) On any frequency outside the 746-758 MHz band, the power of any emission shall be attenuated outside the band below the transmitter power (P) by at least $43 + 10 \log(P)$ dB;
- (2) On any frequency outside the 776-788 MHz band, the power of any emission shall be attenuated outside the band below the transmitter power (P) by at least $43 + 10 \log(P)$ dB;
- (3) On all frequencies between 763-775 MHz and 793-805 MHz, by a factor not less than $76 + 10 \log(P)$ dB in a 6.25 kHz band segment, for base and fixed stations;
- (4) On all frequencies between 763-775 MHz and 793-805 MHz, by a factor not less than $65 + 10 \log(P)$ dB in a 6.25 kHz band segment, for mobile and portable stations;
- (5) Compliance with the provisions of paragraphs (c)(1) and (c)(2) of this section is based on the use of measurement instrumentation employing a resolution bandwidth of 100 kHz or greater. However, in the 100 kHz bands immediately outside and adjacent to the frequency block, a resolution bandwidth of at least 30 kHz may be employed;

Part 27.53 (h)/(g) Limit		-13 dBm
Part 27.53(f) Limit	Limit out of the band 1559-1610 MHz	-13 dBm
	Limit in the band 1559-1610 MHz	-40 dBm

Measurement Uncertainty

The assessed measurement uncertainty to ensure 95% confidence level for the normal distribution is with the coverage factor $k = \pm 1.96$, $U = \pm 3.55$ dB.

Test Results

Refer to the section 6.1 of this report for test data.

6 Test Results

6.1 Radiated Spurious Emission

Sweep the whole frequency band through the range from 9kHz to the 10th harmonic of the carrier, the emissions below the noise floor will not be recorded in the report.

LTE-M Band 4 QPSK 1.4MHz CH-Middle, RB 1

Harmonic	Frequency (MHz)	SG (dBm)	Cable Loss (dB)	Gain (dBi)	Antenna Polarization	EIRP Level (dBm)	Limit (dBm)	Margin (dB)	Azimuth (deg)
2	3464.25	-67.67	2.70	12.70	Vertical	-57.67	-13.00	44.67	249
3	5197.50	-75.77	3.20	12.50	Vertical	-66.47	-13.00	53.47	11
4	6930.00	-70.36	4.20	11.80	Vertical	-62.76	-13.00	49.76	3
5	8662.50	-63.62	4.40	12.50	Vertical	-55.52	-13.00	42.52	0
6	10395.00	-59.55	4.70	11.30	Vertical	-52.95	-13.00	39.95	168
7	12127.50	-64.27	5.20	13.80	Vertical	-55.67	-13.00	42.67	46
8	13860.00	-58.83	5.70	11.30	Vertical	-53.23	-13.00	40.23	315
9	15592.50	-66.96	6.10	16.80	Vertical	-56.26	-13.00	43.26	14
10	17325.00	-62.68	6.10	14.20	Vertical	-54.58	-13.00	41.58	16

Note: 1. The other Spurious RF Radiated emissions level is no more than noise floor.
 2. The worst emission was found in the antenna is Vertical position.

LTE-M Band 4 QPSK 5MHz CH-Middle, RB 1

Harmonic	Frequency (MHz)	SG (dBm)	Cable Loss (dB)	Gain (dBi)	Antenna Polarization	EIRP Level (dBm)	Limit (dBm)	Margin (dB)	Azimuth (deg)
2	3460.50	-68.39	2.70	12.70	Vertical	-58.39	-13.00	45.39	95
3	5191.50	-75.39	3.20	12.50	Vertical	-66.09	-13.00	53.09	146
4	6930.00	-70.51	4.20	11.80	Vertical	-62.91	-13.00	49.91	156
5	8662.50	-63.53	4.40	12.50	Vertical	-55.43	-13.00	42.43	22
6	10380.00	-60.40	4.70	11.30	Vertical	-53.80	-13.00	40.80	13
7	12110.00	-63.71	5.20	13.80	Vertical	-55.11	-13.00	42.11	305
8	13840.00	-58.30	5.70	11.30	Vertical	-52.70	-13.00	39.70	69
9	15570.00	-67.31	6.10	16.80	Vertical	-56.61	-13.00	43.61	4
10	17300.00	-61.99	6.10	14.20	Vertical	-53.89	-13.00	40.89	49

Note: 1.The other Spurious RF Radiated emissions level is no more than noise floor.
2. The worst emission was found in the antenna is Vertical position.

LTE-M Band 4 QPSK 20MHz CH-Middle, RB 1

Harmonic	Frequency (MHz)	SG (dBm)	Cable Loss (dB)	Gain (dBi)	Antenna Polarization	EIRP Level (dBm)	Limit (dBm)	Margin (dB)	Azimuth (deg)
2	3447.75	-71.55	2.70	12.70	Vertical	-61.55	-13.00	48.55	98
3	5170.88	-74.56	3.20	12.50	Vertical	-65.26	-13.00	52.26	246
4	6930.00	-70.13	4.20	11.80	Vertical	-62.53	-13.00	49.53	146
5	8662.50	-62.84	4.40	12.50	Vertical	-54.74	-13.00	41.74	97
6	10395.00	-60.23	4.70	11.30	Vertical	-53.63	-13.00	40.63	86
7	12127.50	-63.73	5.20	13.80	Vertical	-55.13	-13.00	42.13	155
8	13860.00	-57.77	5.70	11.30	Vertical	-52.17	-13.00	39.17	315
9	15592.50	-67.70	6.10	16.80	Vertical	-57.00	-13.00	44.00	315
10	17325.00	-62.07	6.10	14.20	Vertical	-53.97	-13.00	40.97	46

Note: 1.The other Spurious RF Radiated emissions level is no more than noise floor.
2. The worst emission was found in the antenna is Vertical position.

LTE-M Band 12 QPSK 1.4MHz CH-Middle, RB 1

Harmonic	Frequency (MHz)	SG (dBm)	Cable Loss (dB)	Gain (dBi)	Antenna Polarization	ERP Level (dBm)	Limit (dBm)	Margin (dB)	Azimuth (deg)
2	1413.60	-52.52	1.70	8.70	Vertical	-47.67	-13.00	34.67	14
3	2120.40	-58.88	2.10	11.10	Vertical	-52.03	-13.00	39.03	22
4	2827.20	-66.32	2.30	13.10	Vertical	-57.67	-13.00	44.67	142
5	3537.50	-65.22	2.60	12.70	Vertical	-57.27	-13.00	44.27	3
6	4245.00	-62.92	3.30	12.50	Vertical	-55.87	-13.00	42.87	49
7	4952.50	-61.83	3.40	12.50	Vertical	-54.88	-13.00	41.88	305
8	5660.00	-60.68	3.30	12.50	Vertical	-53.63	-13.00	40.63	226
9	6367.50	-58.23	3.80	11.50	Vertical	-52.68	-13.00	39.68	60
10	7075.00	-54.56	4.20	11.80	Vertical	-49.11	-13.00	36.11	135

Note: 1.The other Spurious RF Radiated emissions level is no more than noise floor.
2. The worst emission was found in the antenna is Vertical position.

LTE-M Band 12 QPSK 5MHz CH-Middle, RB 1

Harmonic	Frequency (MHz)	SG (dBm)	Cable Loss (dB)	Gain (dBi)	Antenna Polarization	ERP Level (dBm)	Limit (dBm)	Margin (dB)	Azimuth (deg)
2	1410.60	-69.83	1.70	8.70	Vertical	-64.98	-13.00	51.98	285
3	2115.90	-67.64	2.10	11.10	Vertical	-60.79	-13.00	47.79	96
4	2820.00	-66.40	2.30	13.10	Vertical	-57.75	-13.00	44.75	78
5	3525.00	-63.89	2.60	12.70	Vertical	-55.94	-13.00	42.94	149
6	4230.00	-62.15	3.30	12.50	Vertical	-55.10	-13.00	42.10	315
7	4935.00	-63.64	3.40	12.50	Vertical	-56.69	-13.00	43.69	0
8	5640.00	-61.58	3.30	12.50	Vertical	-54.53	-13.00	41.53	49
9	6345.00	-57.56	3.80	11.50	Vertical	-52.01	-13.00	39.01	226
10	7050.00	-54.92	4.20	11.80	Vertical	-49.47	-13.00	36.47	146

Note: 1.The other Spurious RF Radiated emissions level is no more than noise floor.
2. The worst emission was found in the antenna is Vertical position.

LTE-M Band 12 QPSK 10MHz CH-Middle, RB 1

Harmonic	Frequency (MHz)	SG (dBm)	Cable Loss (dB)	Gain (dBi)	Antenna Polarization	ERP Level (dBm)	Limit (dBm)	Margin (dB)	Azimuth (deg)
2	1405.00	-56.78	1.70	8.70	Vertical	-51.93	-13.00	38.93	156
3	2107.50	-60.85	2.10	11.10	Vertical	-54.00	-13.00	41.00	27
4	2810.00	-65.77	2.30	13.10	Vertical	-57.12	-13.00	44.12	163
5	3512.50	-63.51	2.60	12.70	Vertical	-55.56	-13.00	42.56	17
6	4215.00	-61.95	3.30	12.50	Vertical	-54.90	-13.00	41.90	269
7	4917.50	-64.46	3.40	12.50	Vertical	-57.51	-13.00	44.51	225
8	5620.00	-62.34	3.30	12.50	Vertical	-55.29	-13.00	42.29	146
9	6322.50	-57.45	3.80	11.50	Vertical	-51.90	-13.00	38.90	89
10	7025.00	-55.26	4.20	11.80	Vertical	-49.81	-13.00	36.81	6

Note: 1.The other Spurious RF Radiated emissions level is no more than noise floor.
 2. The worst emission was found in the antenna is Vertical position.

LTE-M Band 13 QPSK 5MHz CH-Middle, RB 1

Harmonic	Frequency (MHz)	SG (dBm)	Cable Loss (dB)	Gain (dBi)	Antenna Polarization	EIRP Level (dBm)	Limit (dBm)	Margin (dB)	Azimuth (deg)
2	1559.85	-83.52	1.70	8.70	Vertical	-76.52	-40.00	36.52	142
Harmonic	Frequency (MHz)	SG (dBm)	Cable Loss (dB)	Gain (dBi)	Antenna Polarization	ERP Level (dBm)	Limit (dBm)	Margin (dB)	Azimuth (deg)
3	2616.53	-61.89	2.10	12.00	Vertical	-54.14	-13.00	41.14	79
4	3118.00	-66.20	2.30	13.10	Vertical	-57.55	-13.00	44.55	184
5	3897.50	-58.95	2.90	12.50	Vertical	-51.50	-13.00	38.50	65
6	4677.00	-63.54	3.10	12.50	Vertical	-56.29	-13.00	43.29	22
7	5456.50	-61.34	3.30	12.50	Vertical	-54.29	-13.00	41.29	134
8	6236.00	-59.44	3.50	12.80	Vertical	-52.29	-13.00	39.29	18
9	7015.50	-55.71	4.20	11.80	Vertical	-50.26	-13.00	37.26	94
10	7795.00	-54.37	4.40	12.30	Vertical	-48.62	-13.00	35.62	156

Note: 1.The other Spurious RF Radiated emissions level is no more than noise floor.
 2. The worst emission was found in the antenna is Vertical position.

LTE-M Band 13 QPSK 10MHz CH-Middle, RB 1

Harmonic	Frequency (MHz)	SG (dBm)	Cable Loss (dB)	Gain (dBi)	Antenna Polarization	ERP Level (dBm)	Limit (dBm)	Margin (dB)	Azimuth (deg)
2	1555.65	-70.74	1.70	8.70	Vertical	-65.89	-13.00	52.89	14
3	2617.05	-56.42	2.10	12.00	Vertical	-48.67	-13.00	35.67	48
4	3108.00	-66.39	2.30	13.10	Vertical	-57.74	-13.00	44.74	146
5	3885.00	-62.09	2.90	12.50	Vertical	-54.64	-13.00	41.64	15
6	4662.00	-63.82	3.10	12.50	Vertical	-56.57	-13.00	43.57	308
7	5439.00	-63.78	3.30	12.50	Vertical	-56.73	-13.00	43.73	79
8	6216.00	-60.10	3.50	12.80	Vertical	-52.95	-13.00	39.95	4
9	6993.00	-58.36	4.20	11.80	Vertical	-52.91	-13.00	39.91	30
10	7770.00	-54.59	4.40	12.30	Vertical	-48.84	-13.00	35.84	146

Note: 1.The other Spurious RF Radiated emissions level is no more than noise floor.
2. The worst emission was found in the antenna is Vertical position.

LTE-M Band 66 QPSK 1.4MHz CH-Middle, RB 1

Harmonic	Frequency (MHz)	SG (dBm)	Cable Loss (dB)	Gain (dBi)	Antenna Polarization	EIRP Level (dBm)	Limit (dBm)	Margin (dB)	Azimuth (deg)
2	3509.25	-66.14	2.70	12.70	Vertical	-56.14	-13.00	43.14	3
3	5262.50	-71.58	3.20	12.50	Vertical	-62.28	-13.00	49.28	13
4	7018.00	-67.63	4.20	11.80	Vertical	-60.03	-13.00	47.03	256
5	8772.50	-65.17	4.40	12.50	Vertical	-57.07	-13.00	44.07	9
6	10527.00	-63.17	4.70	11.80	Vertical	-56.07	-13.00	43.07	149
7	12281.50	-64.60	5.20	13.80	Vertical	-56.00	-13.00	43.00	226
8	14036.00	-60.48	5.70	13.20	Vertical	-52.98	-13.00	39.98	11
9	15790.50	-67.18	6.10	16.80	Vertical	-56.48	-13.00	43.48	315
10	17545.00	-63.35	6.10	14.20	Vertical	-55.25	-13.00	42.25	135

Note: 1.The other Spurious RF Radiated emissions level is no more than noise floor.
2. The worst emission was found in the antenna is Vertical position.

LTE-M Band 66 QPSK 5MHz CH-Middle, RB 1

Harmonic	Frequency (MHz)	SG (dBm)	Cable Loss (dB)	Gain (dBi)	Antenna Polarization	EIRP Level (dBm)	Limit (dBm)	Margin (dB)	Azimuth (deg)
2	3486.00	-65.86	2.70	12.70	Vertical	-55.86	-13.00	42.86	135
3	5229.00	-75.40	3.20	12.50	Vertical	-66.10	-13.00	53.10	315
4	6972.00	-70.06	4.20	11.80	Vertical	-62.46	-13.00	49.46	46
5	8715.00	-63.99	4.40	12.50	Vertical	-55.89	-13.00	42.89	225
6	10458.00	-60.93	4.70	11.80	Vertical	-53.83	-13.00	40.83	147
7	12201.00	-63.39	5.20	13.80	Vertical	-54.79	-13.00	41.79	90
8	13944.00	-61.68	5.70	13.20	Vertical	-54.18	-13.00	41.18	122
9	15687.00	-66.72	6.10	16.80	Vertical	-56.02	-13.00	43.02	226
10	17430.00	-64.47	6.10	14.20	Vertical	-56.37	-13.00	43.37	1

Note: 1.The other Spurious RF Radiated emissions level is no more than noise floor.
2. The worst emission was found in the antenna is Vertical position.

LTE-M Band 66 QPSK 20MHz CH-Middle, RB 1

Harmonic	Frequency (MHz)	SG (dBm)	Cable Loss (dB)	Gain (dBi)	Antenna Polarization	EIRP Level (dBm)	Limit (dBm)	Margin (dB)	Azimuth (deg)
2	3472.88	-70.72	2.70	12.70	Vertical	-60.72	-13.00	47.72	304
3	5209.00	-74.83	3.20	12.50	Vertical	-65.53	-13.00	52.53	79
4	6945.75	-70.45	4.20	11.80	Vertical	-62.85	-13.00	49.85	26
5	8682.00	-63.48	4.40	12.50	Vertical	-55.38	-13.00	42.38	114
6	10418.63	-61.12	4.70	11.80	Vertical	-54.02	-13.00	41.02	305
7	12455.00	-65.91	5.20	13.80	Vertical	-57.31	-13.00	44.31	97
8	13891.50	-61.61	5.70	13.20	Vertical	-54.11	-13.00	41.11	134
9	15627.00	-67.07	6.10	16.80	Vertical	-56.37	-13.00	43.37	6
10	17364.38	-62.88	6.10	14.20	Vertical	-54.78	-13.00	41.78	99

Note: 1.The other Spurious RF Radiated emissions level is no more than noise floor.
2. The worst emission was found in the antenna is Vertical position.

LTE-M Band 85 QPSK 5MHz CH-Middle, RB 1

Harmonic	Frequency (MHz)	SG (dBm)	Cable Loss (dB)	Gain (dBi)	Antenna Polarization	EIRP Level (dBm)	Limit (dBm)	Margin (dB)	Azimuth (deg)
2	1410.00	-63.86	2.70	12.70	Vertical	-53.86	-13.00	40.86	14
3	2114.26	-68.19	3.20	12.50	Vertical	-58.89	-13.00	45.89	25
4	2818.00	-68.49	4.20	11.80	Vertical	-60.89	-13.00	47.89	117
5	3522.50	-66.15	4.40	12.50	Vertical	-58.05	-13.00	45.05	305
6	4227.00	-61.08	4.70	11.80	Vertical	-53.98	-13.00	40.98	24
7	4931.50	-63.26	5.20	13.80	Vertical	-54.66	-13.00	41.66	156
8	5636.00	-61.85	5.70	13.20	Vertical	-54.35	-13.00	41.35	114
9	6340.50	-63.09	6.10	16.80	Vertical	-52.39	-13.00	39.39	93
10	7045.00	-57.97	6.10	14.20	Vertical	-49.87	-13.00	36.87	26

Note: 1.The other Spurious RF Radiated emissions level is no more than noise floor.
 2. The worst emission was found in the antenna is Vertical position.

LTE-M Band 85 QPSK 10MHz CH-Middle, RB 1

Harmonic	Frequency (MHz)	SG (dBm)	Cable Loss (dB)	Gain (dBi)	Antenna Polarization	EIRP Level (dBm)	Limit (dBm)	Margin (dB)	Azimuth (deg)
2	1405.40	-61.22	2.70	12.70	Vertical	-51.22	-13.00	38.22	49
3	2108.06	-70.12	3.20	12.50	Vertical	-60.82	-13.00	47.82	29
4	2808.00	-68.30	4.20	11.80	Vertical	-60.70	-13.00	47.70	36
5	3510.00	-64.90	4.40	12.50	Vertical	-56.80	-13.00	43.80	224
6	4212.00	-62.55	4.70	11.80	Vertical	-55.45	-13.00	42.45	66
7	4914.00	-63.63	5.20	13.80	Vertical	-55.03	-13.00	42.03	46
8	5616.00	-62.13	5.70	13.20	Vertical	-54.63	-13.00	41.63	305
9	6318.00	-62.72	6.10	16.80	Vertical	-52.02	-13.00	39.02	13
10	7020.00	-57.93	6.10	14.20	Vertical	-49.83	-13.00	36.83	135

Note: 1.The other Spurious RF Radiated emissions level is no more than noise floor.
 2. The worst emission was found in the antenna is Vertical position.

7 Main Test Instruments

Name	Manufacturer	Type	Serial Number	Calibration Date	Expiration Date
Spectrum Analyzer	R&S	FSV30	100815	2023-12-05	2024-12-04
Loop Antenna	SCHWARZBECK	FMZB1519	1519-047	2023-04-16	2026-04-15
TRILOG Broadband Antenna	SCHWARZBECK	VULB 9163	01439	2021-06-30	2024-06-29
Horn Antenna	SCHWARZBECK	BBHA 9120D	1594	2023-12-05	2026-12-04
Software	R&S	EMC32	10.35.10	/	/

ANNEX A: The EUT Appearance

The EUT Appearance are submitted separately.

ANNEX B: Test Setup Photos

The Test Setup Photos are submitted separately.

***** END OF REPORT *****