

Features

- SOC features
 - Built-in Tensilica L106 ultra-low power consumption 32-bit cpu, the main frequency can be 80MHz and 160MHz, also support RTOS;
 - Built-in TCP/IP protocol stack;
 - Built-in 1 channel 10-bit high precision ADC;
 - Interfaces include HSPI, UART, I2C, I2S, IR Remote Control, PWM, GPIO;
 - 20uA deep-sleep current, less than 5uA cut-off current;
 - 2ms wake-up time;
 - 1.0mW consume power (DTIM3 and standby state);
- Wi-Fi features
 - Support 802.11 b/g/n/e/i
 - Support three modes: Station, SoftAP, and SoftAP+STA;
 - Support Wi-Fi Direct (P2P);
 - Support hardware acceleration for CCMP (CBC-MAC, computation mode), TKIP (MIC, RC4), WAPI(SMS4), WEP(RC4), CRC;
 - P2P detection, P2P GO mode/GC mode and P2P power management;
 - WPA/PA2 PSK and WPS;
 - Support 802.11 i security: pre-certification and TSN;
 - Support 802.11n (2.4 GHz);
 - 802.1h/RFC1042 frame encapsulation;
 - Support seamless roam;
 - Support AT remote upgrade and cloud OTA upgrade;
 - Support SmartConfig function for Android and iOS device.

Module Interface

- 2xUART
- 1xADC
- 1xEn
- 1xWakeup pin
- 1xHSPI
- 1xI2C
- 1xI2S
- 11xGPIOs
- 4M SPI Flash
- **Working temperature:** -40°C-105°C
- **Module size:** 16mm×24mm

Applications

- Serial transparent transmission;
- WiFi prober;
- Smart power plug/Smart LED light;
- Mesh networks;
- Sensor networks;
- Wireless location recognition; ● Wireless location system beacon;
- Industrial wireless control.

Module Type

Name	Antenna Type
XH-S3E	PCB Antenna

Module Structure

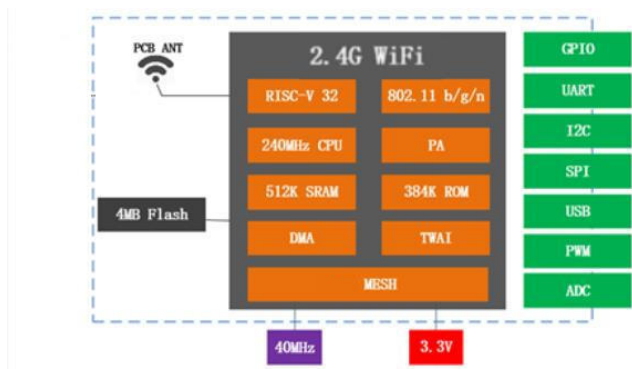

Update Record

Date	Version	Update
2017-3-14	V1.0	Initial version
2017-3-18	V1.1	Add system design

Table of Contents

1. Introduction	4
2. Interface Definition.....	6
3. Shape and Size.....	7
4. Electronical Characteristics	10
5. Power Consumption	10
6. Wi-Fi RF Characteristics	11
8. Module Schematic	13
9. The Recommended PCB Design (Take XH-S3E as an example).....	14
10. Peripheral Design Suggestion.....	15

1. Introduction

The WiFi module XH-S3E is manufactured by using a high-performance chip named ESP8684. This small chip is encapsulated an enhanced Tensilica’s L106 diamond series 32-bit kernel CPU with a SRAM. Thus, ESP8684 has the complete function Wi-Fi function; it can be applied independently, and also can be used as a slaver working with other host CPU. When ESP8684 is applied as a slaver, it can start from the onboard flash. The built-in high-speed buffer is not only benefit to improve the system performance, but optimize the store system. In addition, XH-S3E WiFi module can be used as Wi-Fi adapter by SPI/SDIO or I2C/UART interface, when it is applied to other MCU design.

The XH-S3E WiFi module supports the standard IEEE802.11 b/g/n/e/i protocol and the complete TCP/IP protocol stack. User can use it to add the WiFi function for the installed devices, and also can be viewed as a independent network controller. Anyway, XH-S3E module provides many probabilities with the best price.

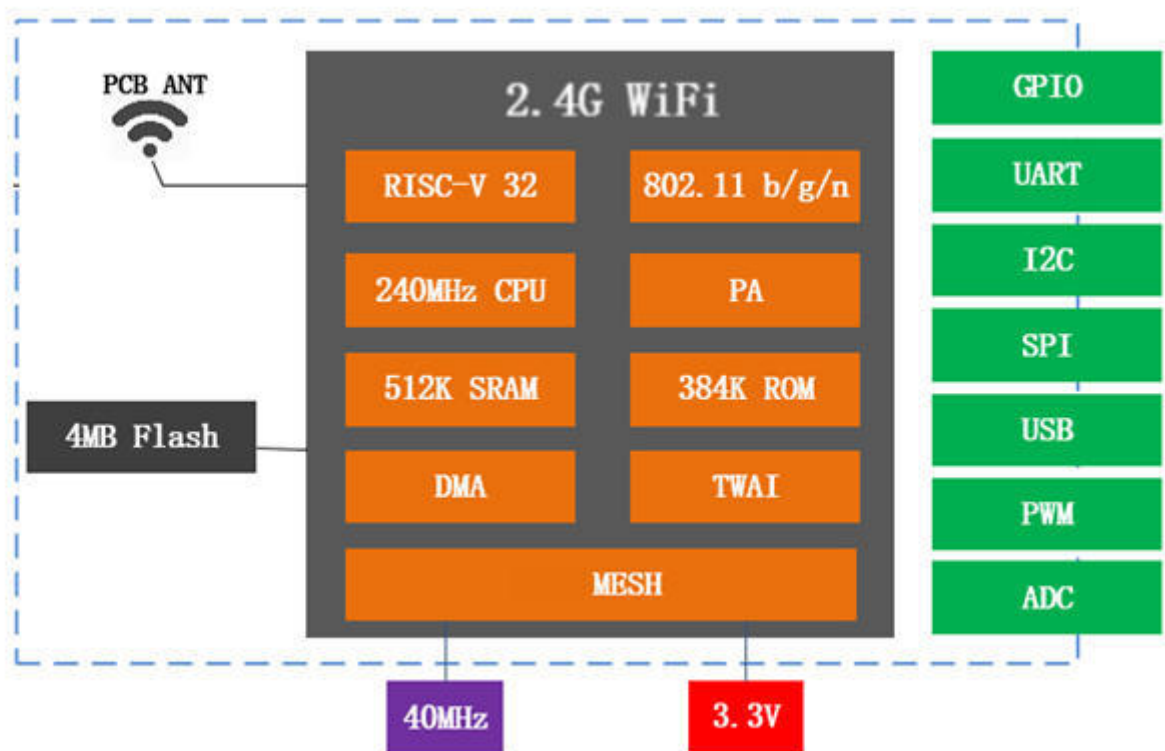

Fig. 1.1 XH-S3E Module Structure

Technical parameters for XH-S3E are listed as follows.

Table 1.1 XH-S3E Parameters

Types	Items	Parameters
Wi-Fi	Frequency	2.4G~2.5G(2400M~2483.5M)
	Transmit power	802.11b: +16 dBm
		802.11g: +15 dBm
		802.11n: +14 dBm
	Receiver sensitivity	802.11b: -91 dbm (11Mbps)
		802.11g: -75 dbm (54Mbps)
802.11n: -72 dbm (MCS7)		
Antenna	PCB antenna / U.F.L antenna	
Hardware	CPU	Tensilica L106 32 bit MCU
	Interface	UART/SDIO/SPI/I2C/I2S/IR control
		GPIO/ADC/PWM/SPI/I2C/I2S
	Working voltage	2.5V ~ 3.6V
	Working current	Average current: 80 mA,Peak current: >200mA
	Working temperature	-40°C ~105°C
	Environment temperature	-40°C ~ 105°C
Shape	16*24*3mm	
Software Types	Wi-Fi working mode	Station/SoftAP/SoftAP+Station
	Security mode	WPA/WPA2
	Encryption type	WEP/TKIP/AES
	Update firmware	UART Download/OTA
	Software develop	Non-RTOS/RTOS/Arduino IDE etc.
	Network protocol	IPv4, TCP/UDP/HTTP/FTP/MQTT

2. Interface Definition

XH-S3E module interface definition is shown as below.

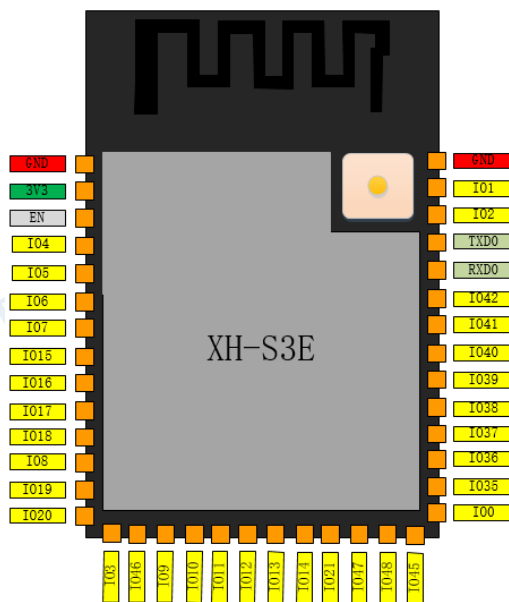

Fig. 2.1 XH-S3E Pin Definition

Working mode and pin function is shown in Table 2.1.

Table 2.1 Working mode

Mode	GPIO
UART Download Mode	Low
Flash Boot Mode	High

Table 2.2 Pin Function Definition

name	Serial number	type	Feature
GND	1	P	Ground connection
3V3	2	P	Power supply
EN	3	I	High: chip enabled; Low: chip off; Make sure the EN pin does not float.
IO4	4	I/O/T	RTC_GPIO4, GPIO4, TOUCH4, ADC1_CH3
IO5	5	I/O/T	RTC_GPIO5, GPIO5, TOUCH5, ADC1_CH4
IO6	6	I/O/T	RTC_GPIO6, GPIO6, TOUCH6, ADC1_CH5
IO7	7	I/O/T	RTC_GPIO7, GPIO7, TOUCH7, ADC1_CH6
IO15	8	I/O/T	RTC_GPIO15, GPIO15, U0RTS, ADC2_CH4, XTAL_32K_P
IO16	9	I/O/T	RTC_GPIO16, GPIO16, U0CTS, ADC2_CH5, XTAL_32K_N
IO17	10	I/O/T	RTC_GPIO17, GPIO17, U1TXD, ADC2_CH6
IO18	11	I/O/T	RTC_GPIO18, GPIO18, U1RXD, ADC2_CH7, CLK_OUT3
IO8	12	I/O/T	RTC_GPIO8, GPIO8, TOUCH8, ADC1_CH7, SUBSPICS1
IO19	13	I/O/T	RTC_GPIO19, GPIO19, U1RTS, ADC2_CH8, CLK_OUT2, USB_D-
IO20	14	I/O/T	RTC_GPIO20, GPIO20, U1CTS, ADC2_CH9, CLK_OUT1, USB_D+
IO3	15	I/O/T	RTC_GPIO3, GPIO3, TOUCH3, ADC1_CH2
IO46	16	I/O/T	GPIO4 6
IO9	17	I/O/T	RTC_GPIO9, GPIO9, TOUCH9, ADC1_CH8, FSPiHD, SUBSPiHD
IO10	18	I/O/T	RTC_GPIO10, GPIO10, TOUCH10, ADC1_CH9, FSPiCS0, FSPiIO4, SUBSPiCS0
IO11	19	I/O/T	RTC_GPIO11, GPIO11, TOUCH11, ADC2_CH0, FSPiD, FSPiIO5, SUBSPiD
IO12	20	I/O/T	RTC_GPIO12, GPIO12, TOUCH12, ADC2_CH1, FSPiCLK, FSPiIO6, SUBSPiCLK
IO13	21	I/O/T	RTC_GPIO13, GPIO13, TOUCH13, ADC2_CH2, FSPiQ, FSPiIO7, SUBSPiQ
IO14	22	I/O/T	RTC_GPIO14, GPIO14, TOUCH14, ADC2_CH3, FSPiWP, FSPiDQS, SUBSPiWP
IO21	23	I/O/T	RTC_GPIO21, GPIO21
IO47	24	I/O/T	SPiCLK_P_DIFF, GPIO47, SUBSPiCLK_P_DIFF
IO48	25	I/O/T	SPiCLK_N_DIFF, GPIO48, SUBSPiCLK_N_DIFF
IO45	26	I/O/T	GPIO4 5
IO0	27	I/O/T	RTC_GPIO0, GPIO0
IO35 ^b	28	I/O/T	SPiIO6, GPIO35, FSPiD, SUBSPiD
IO36 ^b	29	I/O/T	SPiIO7, GPIO36, FSPiCLK, SUBSPiCLK
IO37 ^b	30	I/O/T	SPiDQS, GPIO37, FSPiQ, SUBSPiQ
IO38	31	I/O/T	GPIO38, FSPiWP, SUBSPiWP
IO39	32	I/O/T	MTCK, GPIO39, CLK_OUT3, SUBSPiCS1
IO40	33	I/O/T	MTDO, GPIO40, CLK_OUT2

IO41	34	I/O/T	MTDI, GPIO41, CLK_OUT1
------	----	-------	------------------------

名称	序号	类型 ^a	功能
IO42	35	I/O/T	MTMS, GPIO42
RXD0	36	I/O/T	U0RXD, GPIO44, CLK_OUT2
TXD0	37	I/O/T	U0TXD, GPIO43, CLK_OUT1
IO2	38	I/O/T	RTC_GPIO2, GPIO2, TOUCH2, ADC1_CH1
IO1	39	I/O/T	RTC_GPIO1, GPIO1, TOUCH1, ADC1_CH0
GND	40	P	Ground connection
EPAD	41	P	Ground connection

3. Shape and Size

Shape and size for XH-S3E can be shown as follows. The Flash of XH-S3E is 32 Mbits (4M Bytes) .

Fig.3.1 Shape for XH-S3E



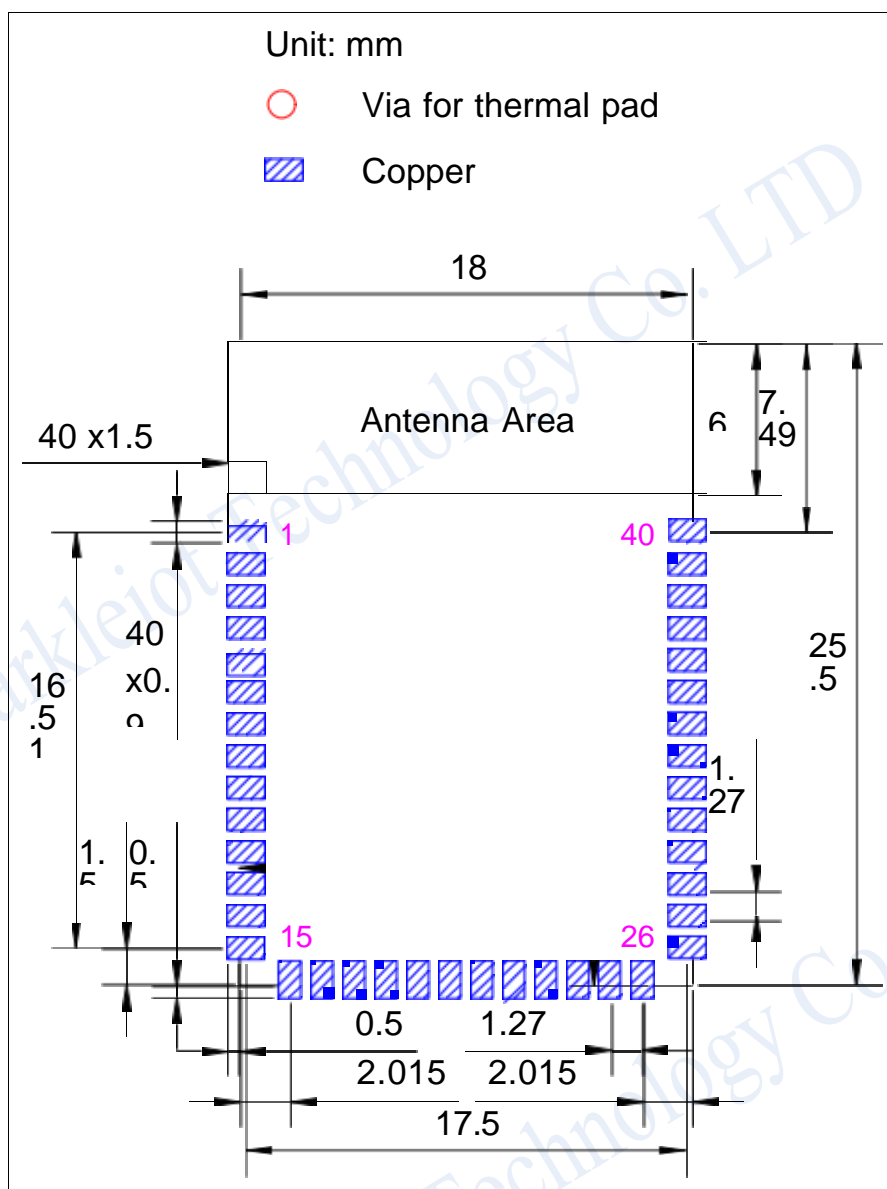

(a) Vertical View



(b) Side View

Fig. 3.1 Size for XH-S3E

Table 3.1 Size for XH-S3E

Length	Width	Height	PAD Size (bottom)	Distance between Pins
25.5 mm	18 mm	3 mm	0.45 mm x 0.9 mm	0.8 ± 0.1 mm

4. Electrical Characteristics

Table 4.1 Electrical Characteristics

Parameters	Condition	Min	Classical	Max	Unit	
Store Temperature	-	-40	Normal	125	°C	
Sold Temperature	IPC/JEDEC J-STD-020	-	-	260	°C	
Working Voltage	-	2.5	3.3	3.6	V	
I/O	V _{IL} /V _{IH}	-	-0.3/0.75V _{IO}	-	0.25V _{IO} /3.6	I/O
	V _{OL} /V _{OH}	-	N/0.8V _{IO}	-	0.1V _{IO} /N	
	I _{MAX}	-	-	-	12	
Electrostatic release quantity (Human model)	TAMB=25°C	-	-	2	KV	
Electrostatic release quantity (Human model)	TAMB=25°C	-	-	0.5	KV	

5. Power Consumption

Table 5.1 Power Consumption

Parameters	Min	Classical	Max	Unit
Tx802.11b, CCK 11Mbps, POUT=+17dBm	-	170	-	mA
Tx802.11g, OFDM 54 Mbps, POUT =+15dBm	-	140	-	mA
Tx802.11n,MCS7,POUT =+13dBm	-	120	-	mA
Rx 802.11b, 1024 Bytes, -80dBm	-	50	-	mA
Rx 802.11g, 1024 Bytes, -70dBm	-	56	-	mA
Rx 802.11n, 1024 Bytes, -65dBm	-	56	-	mA
Modem-sleep①	-	15	-	mA
Light-sleep②	-	0.9	-	mA
Deep-sleep③	-	20	-	µA

Note

①: Modem-Sleep mode can be used for the case that CPU is always working, e.g., PWM or I2S etc. If WiFi is connected and no data is to transmitted, in this case, WiFi modem can be closed to save power energy. For example, if at DTIM3 status, keep asleep at 300ms, Then, the module can wake up to receive the Beacon package within 3ms and the current being 15mA.

②: Light-Sleep mode can used for the case that CUP can stop the application temporally, e.g., Wi-Fi Switch . If Wi-Fi is connected and there is no data packet to transmitted, by the 802.11 standard (e.g., U-APSD), module can close Wi-Fi Modem and stop CPU to save power. For example, at DTIM3, keep up sleeping at 300ms, it would receive the Beacon package from AP after each 3ms, then the whole average current is about 0.9mA.

③ Deep-Sleep mode is applied to the case that Wi-Fi is not necessary to connect all the time, just send a data packet after a long time (e.g., transmit one temperate data each 100s) . it just need 0.3s-1s to connect AP after each 300s, and the whole average current is much smaller 1mA.

6. Wi-Fi RF Characteristics

The data in the following Table is gotten when voltage is 3.3V and 1.1V in the indoor temperature environment.

Table 6.1 Wi-Fi RF Characteristics

Parameters	Min	Classical	Max	Unite
Input frequency	2412	-	2484	MHz
Input impedance	-	50	-	Ω
Input reflection	-	-	-10	dB
At 72.2Mbps, output power consumption for PA	15.5	16.5	17.5	dBm
At 11b mode, output power consumption for PA	19.5	20.5	21.5	dBm
Sensibility	-	-	-	-
DSSS, 1Mbps	-	-98	-	dBm
CCK11, Mbps	-	-91	-	dBm
6Mbps(1/2 BPSK)	-	-93	-	dBm
54Mbps(3/4 64-QAM)	-	-75	-	dBm
HT20, MCS7(65 Mbps, 72.2 Mbps)	-	-72	-	dBm
Adjacent Inhibition				
OFDM, 6Mbps	-	37	-	dB
OFDM, 54Mbps	-	21	-	dB
HT20, MCS0	-	37	-	dB
HT20, MCS7	-	20	-	dB

7. The Recommended Sold Temperature Curve



图 7.1 Temperature Curve when sold

8. Module Schematic

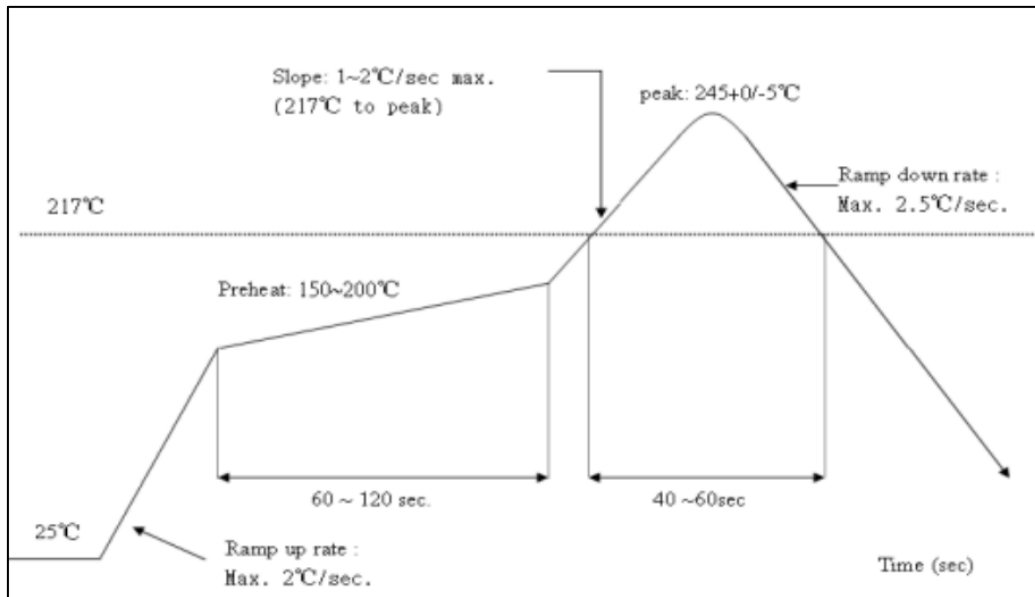
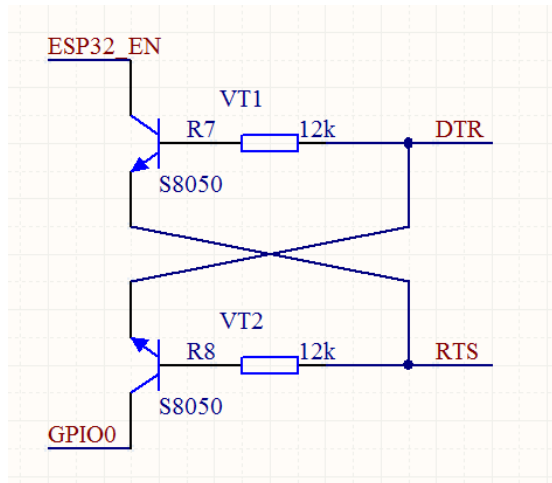
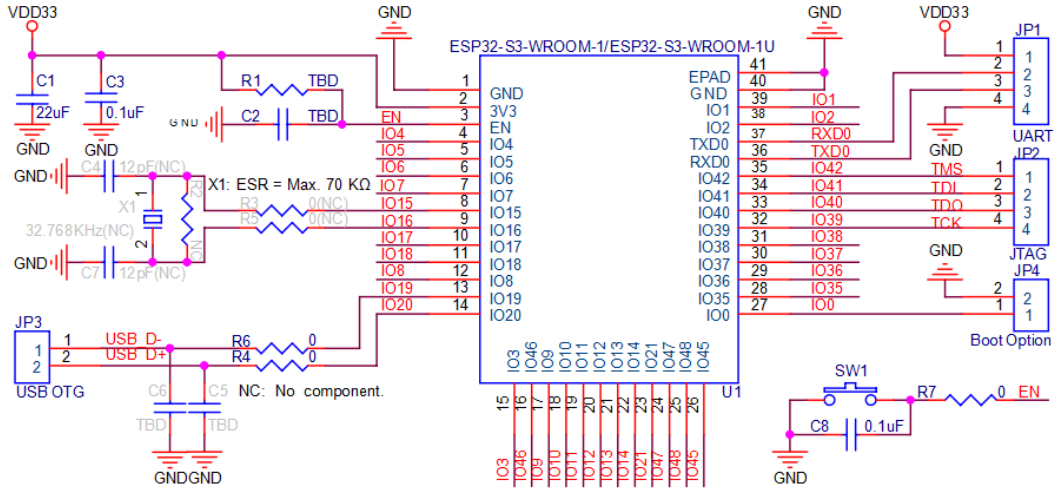

Note

- (1) the working voltage for module is DC 3.3V;
- (2) the max current from IO of this module is 12mA;
- (3) RST Pin is enabled when it is low level; and EN pin is enabled when it is high level;
- (4) WiFi module is at update mode: GPIO0 is low level, then module reset to power; Wi-Fi module is at working mode: GPIO0 is at high level, and then reset to power;
- (5) Wi-Fi module is connected to RXD of the other MCU, and TXD is connected to RXD of the other MCU.

9. The Recommended PCB Design (Take XH-C2F as an example)

XH-C2F Wi-Fi module can be sold on PCB board directly. For the high RF performance for the device, please notice the placement of the module. There are three ways to use the module.

Solution 1:optical solution. The WiFi module is placed on the side of the board, and the antennas are all exposed, and there is no metal material around the antenna, including wires, metal casings, weight plates, and the like.

Solution 2:suboptical solution. The WiFi module is placed on the side of the board, and the antenna below is hollowed out. There is a gap of not less than 5 mm reserved with the PCB, and there is no metal material around the antenna, including wires, metal casings, weight plates, and the like.

Solution 3: The WiFi module is placed on the side of the board, and the PCB area under the antenna is empty, and copper cannot be laid.

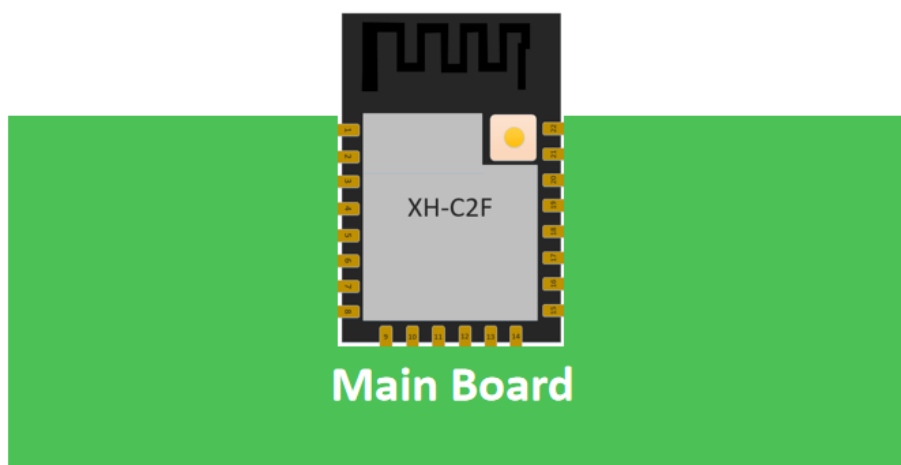

Fig.10.1 Solution 1

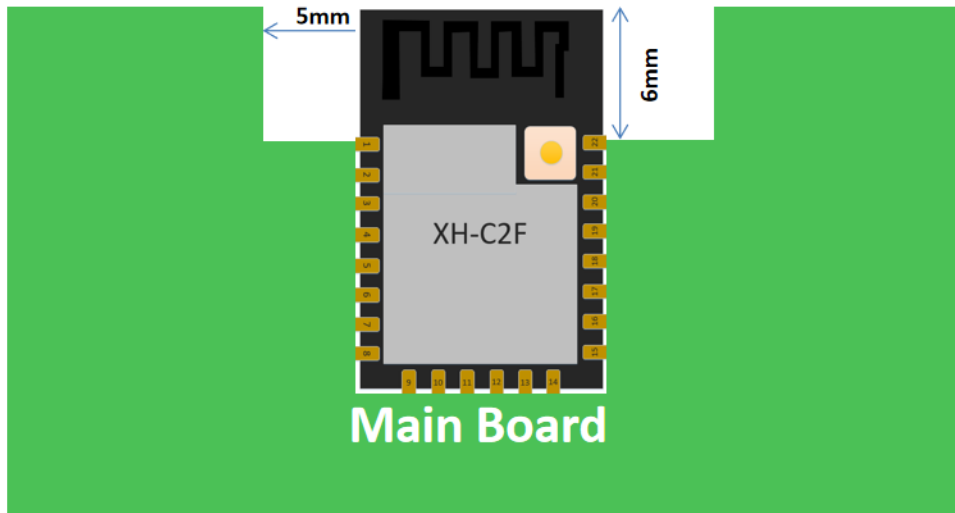

Fig.10.2 Solution 2

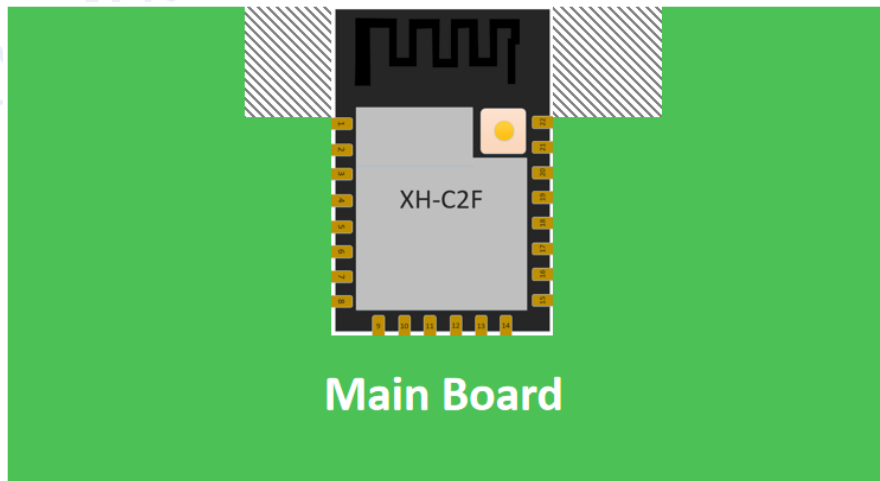

Fig.10.3 Solution 3

10. Peripheral Design Suggestion

Wi-Fi module is already integrated into high-speed GPIO and Peripheral interface, which may be generated the switch noise. If there is a high request for the power consumption and EMI characteristics, it is suggested to connect a serial 10~100 ohm resistance, which can suppress overshoot when switching power supply, and can smooth signal. At the same time, it also can prevent electrostatic discharge (ESD).

Disclaimer and Copyright Notice

The information in this article, including the URL for reference, if there is any change, without prior notice.

Documents are provided by the current version without any guarantee responsibility, including merchantability, suitable for any particular purpose or non-infringement guarantees, and any guarantees presented by any proposal, specification, or sample mentioned elsewhere. This document has no any responsibility, including the use of the information within this document produced by the infringement of any patent rights. This document in this, by estoppel or otherwise, grant any intellectual property licensing, whether express or implied license.

The Wi-Fi alliance marks shall be owned by the Wi-Fi alliance.

All the mentioned brand names, trademarks and registered trademarks presented in this document are the property of their respective owners, and hereby declare.

Shenzhen Sparkleiot Technology Co., Ltd. is a national-level high-tech and innovative technology enterprise, focusing on R&D, production and sales of smart home and IOT products.

The company was established in 2014. At the beginning of its establishment, it was adhering to the concept of "science and technology change lives, and products enter thousands of households". After just a few years, the company has continuously launched the market's cost-effective 2.4G WiFi module, 2.4G WiFi module, 4GWiFi module, and quickly won unanimous praise in the market.

In 2018, the company established a smart home department, focusing on the smart electrical lighting industry. The company's products are exported to the Americas, Europe and other regions, and continue to receive praise from customers.

FCC Statement

This device complies with part 15 of the FCC rules. Operation is subject to the following two conditions: (1) this device may not cause harmful interference, and (2) this device must accept any interference received, including interference that may cause undesired operation.

Changes or modifications not expressly approved by the party responsible for compliance could void the user's authority to operate the equipment.

NOTE: This equipment has been tested and found to comply with the limits for a Class B digital device, pursuant to part 15 of the FCC Rules. These limits are designed to provide reasonable protection against harmful interference in a residential installation. This equipment generates uses and can radiate radio frequency energy and, if not installed and used in accordance with the instructions, may cause harmful interference to radio communications. However, there is no guarantee that interference will not occur in a particular installation. If this equipment does cause harmful interference to radio or television reception, which can be determined by turning the equipment off and on, the user is encouraged to try to correct the interference by one or more of the following measures:

- Reorient or relocate the receiving antenna.
- Increase the separation between the equipment and receiver.
- Connect the equipment into an outlet on a circuit different from that to which the receiver is connected.
- Consult the dealer or an experienced radio/TV technician for help important announcement

Important Note:

Radiation Exposure Statement

This equipment complies with FCC radiation exposure limits set forth for an uncontrolled environment. This equipment should be installed and operated with minimum distance 20cm between the radiator and your body.

This transmitter must not be co-located or operating in conjunction with any other antenna or transmitter.

Country Code selection feature to be disabled for products marketed to the US/Canada.

This device is intended only for OEM integrators under the following conditions:

1. The antenna must be installed such that 20 cm is maintained between the antenna and users, and
2. The transmitter module may not be co-located with any other transmitter or antenna,
3. For all products market in US, OEM has to limit the operation channels in CH1 to CH11 for 2.4G band by supplied firmware programming tool. OEM shall not supply any tool or info to the end-user regarding to Regulatory Domain change. (if modular only test Channel 1-11)

As long as the three conditions above are met, further transmitter testing will not be required. However, the OEM integrator is still responsible for testing their end-product for any additional compliance requirements required with this module installed.

Important Note:

In the event that these conditions cannot be met (for example certain laptop configurations or co-location with another transmitter), then the FCC authorization is no longer considered valid and the FCC ID cannot be used on the final product. In these circumstances, the OEM integrator will be responsible for re-evaluating the end product (including the transmitter) and obtaining a separate FCC authorization.

End Product Labeling

The final end product must be labeled in a visible area with the following" Contains FCC ID: **2BCLR-XH-S3E**"

Manual Information to the End User

The OEM integrator has to be aware not to provide information to the end user regarding how to install or remove this RF module in the user's manual of the end product which integrates this module.

The end user manual shall include all required regulatory information/warning as show in this manual.

**Integration instructions for host product manufacturers according to KDB 996369 D03
OEM Manual v01**

2.2 List of applicable FCC rules

CFR 47 FCC PART 15 SUBPART C has been investigated. It is applicable to the modular transmitter

2.3 Specific operational use conditions

This module is stand-alone modular. If the end product will involve the Multiple simultaneously transmitting condition or different operational conditions for a stand-alone modular transmitter in a host, host manufacturer have to consult with module manufacturer for the installation method in end system.

2.4 Limited module procedures

Not applicable

2.5 Trace antenna designs

Not applicable

2.6 RF exposure considerations

This equipment complies with FCC radiation exposure limits set forth for an uncontrolled environment. This equipment should be installed and operated with minimum distance 20cm between the radiator & your body.

2.7 Antennas

This radio transmitter **FCC ID:2BCLR-XH-S3E** has been approved by Federal Communications Commission to operate with the antenna types listed below, with the maximum permissible gain indicated. Antenna types not included in this list that have a gain greater than the maximum gain indicated for any type listed are strictly prohibited for use with this device.

Antenna No.	Model No. of antenna:	Type of antenna:	Gain of the antenna (Max.)	Frequency range:
2.4GWiFi	/	PCB Antenna	0.76dBi for 2412-2462MHz;	

2.8 Label and compliance information

The final end product must be labeled in a visible area with the following" Contains **FCC ID:2BCLR-XH-S3E**".

2.9 Information on test modes and additional testing requirements

Host manufacturer is strongly recommended to confirm compliance with FCC requirements for the transmitter when the module is installed in the host.

2.10 Additional testing, Part 15 Subpart B disclaimer

Host manufacturer is responsible for compliance of the host system with module installed with all other applicable requirements for the system such as Part 15 B.