



HUAK TESTING

FCC TEST REPORT

Prepared for :

Shenzhen Yidian International Digital Co., LTD

**Floor 3, Block B, Gushu Runfeng Industrial Park, Xixiang Street, Bao 'an
District, Shenzhen, China**

Product Name: Camera Detector

Trade Mark: N/A

**Product Model (S): X13, S100, S200, S300, S400, S500, S600,
S700, S800, X14, X15, X16, X17, X18, X19,
X20, X21, X22, X23, X24, X25, X26, X27,
X28, X29, X30**

FCC ID: 2BCLC-X13

Date of Test: May 06, 2024 – May 11, 2024

Date of Report: May 11, 2024

Report Number: HK2405062179-1ER

Prepared By :

Shenzhen HUAK Testing Technology Co., Ltd.

1-2/F., Building B2, Junfeng Zhongcheng Zhizao Innovation Park, Heping,

Fuhai Street, Bao'an District, Shenzhen, Guangdong, China

TEL: +86-755-2302 9901 FAX: +86-755-2302 9901

E-mail: service@cer-mark.com <http://www.cer-mark.com>

The results shown in this test report refer only to the sample(s) tested unless otherwise stated and the sample(s) are retained for 30 days only. The document is issued by HUAK, this document cannot be reproduced except in full with our prior written permission. The more details and the authenticity of the report will be confirmed at <http://www.cer-mark.com>.

TEL : +86-755 2302 9901 FAX : +86-755 2302 9901 E-mail : service@cer-mark.com

Add: 1-2F., Building B2, Junfeng Zhongcheng Zhizao Innovation Park, Heping Community, Fuhai Street, Bao'an District, Shenzhen, Guangdong, China



TEST REPORT VERIFICATION

Applicant : Shenzhen Yidian International Digital Co., LTD

Address : Floor 3, Block B, Gushu Runfeng Industrial Park, Xixiang Street, Bao 'an District, Shenzhen, China

Manufacturer : Shenzhen Yidian International Digital Co., LTD

Address : Floor 3, Block B, Gushu Runfeng Industrial Park, Xixiang Street, Bao 'an District, Shenzhen, China

Product Name : Camera Detector

(A) Product Model : X13

(B) Series Model : S100, S200, S300, S400, S500, S600, S700, S800, X14, X15, X16, X17, X18, X19, X20, X21, X22, X23, X24, X25, X26, X27, X28, X29, X30

(C) Power Supply : DC 5V From Type-C or DC 3.7V From Battery

Standards FCC Part 15 Subpart B
 ANSI C63.4:2019

This device described above has been tested by HUAKE, and the test results show that the equipment under test (EUT) is in compliance with Part 15 of FCC Rules. And it is applicable only to the tested sample identified in the report.

This report shall not be reproduced except in full, without the written approval of HUAKE, this document may be altered or revised by HUAKE, personal only, and shall be noted in the revision of the document.

Test Result **Pass**

Date of Test: May 06, 2024 – May 11, 2024

Prepared by: Kevin Pan
 Project Engineer

Reviewed by: Stiver Wom
 Project Supervisor

Approved by: Jason Zhou
 Technical Director



1 . TEST SUMMARY	5
1.1 TEST FACILITY	6
1.2 MEASUREMENT UNCERTAINTY	6
2 . GENERAL INFORMATION	7
2.1 GENERAL DESCRIPTION OF EUT	7
2.2 DESCRIPTION OF TEST MODES	8
2.3 DESCRIPTION OF TEST SETUP	9
2.4 DESCRIPTION TEST PERIPHERAL AND EUT PERIPHERAL	10
2.5 MEASUREMENT INSTRUMENTS LIST	11
3 . EMC EMISSION TEST	12
3.1 CONDUCTED EMISSION MEASUREMENT	12
3.1.1 POWER LINE CONDUCTED EMISSION	12
3.1.2 TEST PROCEDURE	13
3.1.3 TEST SETUP	13
3.1.4 EUT OPERATING CONDITIONS	13
3.1.5 TEST RESULTS	14
3.2 RADIATED EMISSION MEASUREMENT	16
3.2.1 LIMITS OF RADIATED EMISSION MEASUREMENT	16
3.2.2 TEST PROCEDURE	16
3.2.3 TEST SETUP	17
3.2.4 EUT OPERATING CONDITIONS	17
3.2.5 TEST RESULTS	18
3.2.6 TEST RESULTS(Above 1GHz)	20
4 . EUT TEST PHOTOS	22



**** Modified History ****

Revision	Description	Issued Data	Remark
Revision 1.0	Initial Test Report Release	2024/05/11	Jason Zhou



1. TEST SUMMARY

Test procedures according to the technical standards:

EMC Emission				
Standard	Test Item	Limit	Judgment	Remark
FCC Part 15 Subpart B ANSI C63.4:2019	Conducted Emission	Class B	PASS	
	Radiated Emission	Class B	PASS	

NOTE:

- (1) 'N/A' denotes test is not applicable in this Test Report
- (2) For client's request and manual description, the test will not be executed.



1.1 TEST FACILITY

Shenzhen HUAKE Testing Technology Co., Ltd.
Add. : 1-2/F., Building B2, Junfeng Zhongcheng Zhizao Innovation Park, Heping, Fuhai Street, Bao'an District, Shenzhen, Guangdong, China

Testing Laboratory Authorization:
A2LA Accreditation Code is 4781.01.
FCC Designation Number is CN1229.
Canada IC CAB identifier is CN0045.
CNAS Registration Number is L9589.

1.2 MEASUREMENT UNCERTAINTY

The reported uncertainty of measurement y ± U, where expanded uncertainty U is based on a standard uncertainty multiplied by a coverage factor of k=2, providing a level of confidence of approximately 95 %.

A. Conducted Measurement :

Table with 3 columns: Measurement Frequency Range, Uncertainty, NOTE. Row 1: 150 KHz ~ 30MHz, ±2.71dB

B. Radiated Measurement :

Table with 3 columns: Measurement Frequency Range, Uncertainty, NOTE. Row 1: 30MHz ~ 1000MHz, ±3.90dB. Row 2: 1GHz ~6GHz, ±4.28dB



2. GENERAL INFORMATION

2.1 GENERAL DESCRIPTION OF EUT

Product Name	Camera Detector				
Product Model	X13				
Series Model	S100, S200, S300, S400, S500, S600, S700, S800, X14, X15, X16, X17, X18, X19, X20, X21, X22, X23, X24, X25, X26, X27, X28, X29, X30				
Model Difference	All model's the function, software and electric circuit are the same, only with product model named different. Test sample model: X13.				
Product Description	The EUT is a Camera Detector.				
	<table border="1"> <tr> <td>Operating frequency:</td> <td>N/A</td> </tr> <tr> <td>Connecting I/O port:</td> <td>N/A</td> </tr> </table>	Operating frequency:	N/A	Connecting I/O port:	N/A
	Operating frequency:	N/A			
Connecting I/O port:	N/A				
Based on the application, features, or specification exhibited in User's Manual, the EUT is considered as an ITE/Computing Device. More details of EUT technical specification, please refer to the User's Manual.					
Power Source	DC Voltage				
Power Rating	DC 5V From Type-C or DC 3.7V From Battery				



2.2 DESCRIPTION OF TEST MODES

To investigate the maximum EMI emission characteristics generates from EUT, the test system was pre-scanning tested base on the consideration of following EUT operation mode or test configuration mode which possible have effect on EMI emission level. Each of these EUT operation mode(s) or test configuration mode(s) mentioned above was evaluated respectively.

Pretest Mode	Description
Mode 1	Charging and Working
Mode 2	Charging
Mode 3	Working

For Conducted Test	
Final Test Mode	Description
Mode 1	Charging and Working
Mode 2	Charging
Mode 3	N/A

For Radiated Test	
Final Test Mode	Description
Mode 1	Charging and Working
Mode 2	Charging
Mode 3	Working



2.3 DESCRIPTION OF TEST SETUP

Mode 1:

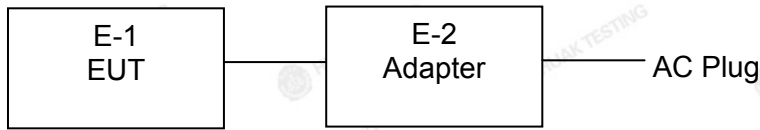

Mode 2:

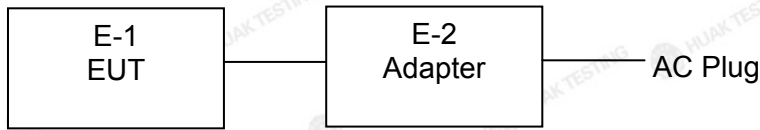

Mode 3:

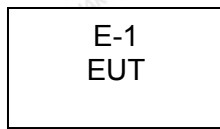



2.4 DESCRIPTION TEST PERIPHERAL AND EUT PERIPHERAL

The EUT has been tested as an independent unit together with other necessary accessories or support units. The following support units or accessories were used to form a representative test configuration during the tests.

Item	Equipment	Trade Mark	Model/Type No.	Series No.	Note
E-1	Camera Detector	N/A	X13	N/A	EUT
E-2	Adapter	HUAWEI	HW-050450C00	N/A	

Item	Shielded Type	Ferrite Core	Length	Note

Note:

- (1) The support equipment was authorized by Declaration of Confirmation.
- (2) For detachable type I/O cable should be specified the length in cm in 『Length』 column.
- (3) “YES” is means “shielded” “with core”; “NO” is means “unshielded” “without core”.



2.5 MEASUREMENT INSTRUMENTS LIST

Item	Equipment	Manufacturer	Model No.	Serial No.	Last Cal.	Cal. Interval
1.	L.I.S.N.	R&S	ENV216	HKE-002	Feb. 20, 2024	1 Year
2.	L.I.S.N.	R&S	ENV216	HKE-059	Feb. 20, 2024	1 Year
3.	EMI Test Receiver	R&S	ESR	HKE-005	Feb. 20, 2024	1 Year
4.	Spectrum analyzer	Agilent	N9020A	HKE-048	Feb. 20, 2024	1 Year
5.	Spectrum analyzer	R&S	FSV3044	HKE-126	Feb. 20, 2024	1 Year
6.	Preamplifier	EMCI	EMC05184 5S	HKE-006	Feb. 20, 2024	1 Year
7.	Preamplifier	Schwarzbeck	BBV 9743	HKE-016	Feb. 20, 2024	1 Year
8.	Preamplifier	A.H. Systems	SAS-574	HKE-182	Feb. 20, 2024	1 Year
9.	6dB Attenuator	Pasternack	6db	HKE-184	Feb. 20, 2024	1 Year
10.	EMI Test Receiver	Rohde & Schwarz	ESR-7	HKE-010	Feb. 20, 2024	1 Year
11.	Broadband Antenna	Schwarzbeck	VULB9168	HKE-167	Feb. 21, 2024	2 Year
12.	Loop Antenna	COM-POWER	AL-130R	HKE-014	Feb. 21, 2024	2 Year
13.	Horn Antenna	Schwarzbeck	9120D	HKE-013	Feb. 21, 2024	2 Year
14.	EMI Test Software	Tonscend	JS32-CE 2.5.0.6	HKE-081	/	/
15.	EMI Test Software	Tonscend	JS32-RE 5.0.0	HKE-082	/	/

The results shown in this test report refer only to the sample(s) tested unless otherwise stated and the sample(s) are retained for 30 days only. The document is issued by HUAK, this document cannot be reproduced except in full with our prior written permission. The more details and the authenticity of the report will be confirmed at <http://www.cer-mark.com>.

TEL : +86-755 2302 9901 FAX : +86-755 2302 9901 E-mail : service@cer-mark.com

Add: 1-2F., Building B2, Junfeng Zhongcheng Zhizao Innovation Park, Heping Community, Fuhai Street, Bao'an District, Shenzhen, Guangdong, China



3. EMC EMISSION TEST

3.1 CONDUCTED EMISSION MEASUREMENT

3.1.1 POWER LINE CONDUCTED EMISSION (Frequency Range 150KHz-30MHz)

FREQUENCY (MHz)	Class A (dBuV)		Class B (dBuV)	
	Quasi-peak	Average	Quasi-peak	Average
0.15 -0.5	79.00	66.00	66 - 56 *	56 - 46 *
0.50 -5.0	73.00	60.00	56.00	46.00
5.0 -30.0	73.00	60.00	60.00	50.00

Note:

- (1) The tighter limit applies at the band edges.
- (2) The limit of " * " marked band means the limitation decreases linearly with the logarithm of the frequency in the range.

The following table is the setting of the receiver

Receiver Parameters	Setting
Attenuation	10 dB
Start Frequency	0.15 MHz
Stop Frequency	30 MHz
IF Bandwidth	9 kHz

3.1.2 TEST PROCEDURE

- a. The EUT was placed 0.4 meters from the horizontal ground plane with EUT being connected to the power mains through a line impedance stabilization network (LISN). All other support equipments powered from additional LISN(s). The LISN provide 50 Ohm/ 50uH of coupling impedance for the measuring instrument.
- b. Interconnecting cables that hang closer than 40 cm to the ground plane shall be folded back and forth in the center forming a bundle 30 to 40 cm long.
- c. I/O cables that are not connected to a peripheral shall be bundled in the center. The end of the cable may be terminated, if required, using the correct terminating impedance. The overall length shall not exceed 1 m.
- d. LISN at least 80 cm from nearest part of EUT chassis.
- e. For the actual test configuration, please refer to the related Item –EUT Test Photos.

3.1.3 TEST SETUP

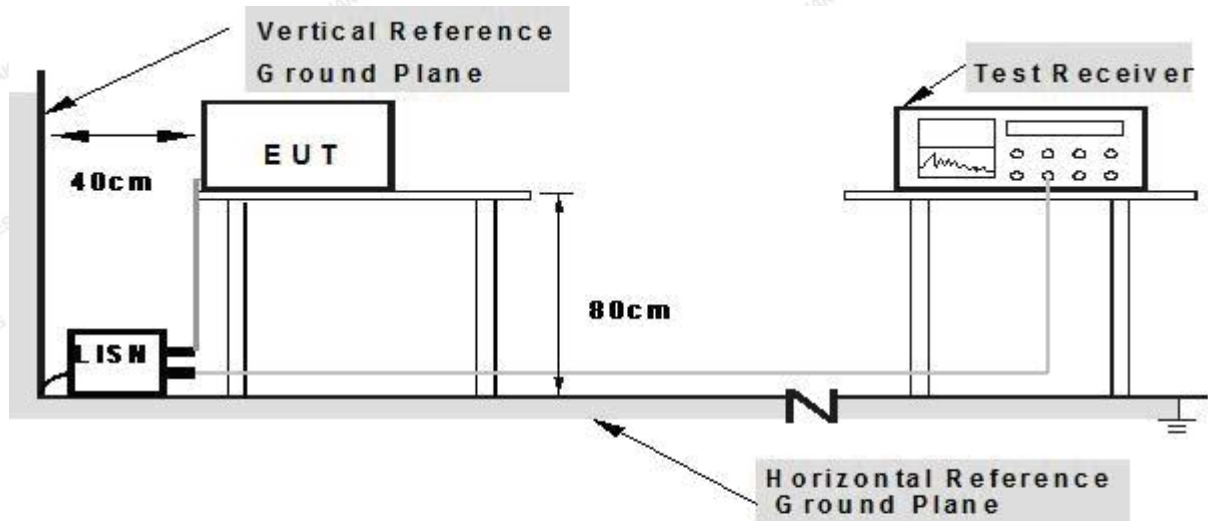

Note: 1. Support units were connected to second LISN.

2. Both of LISNs (AMN) are 80 cm from EUT and at least 80 from other units and other metal planes

3.1.4 EUT OPERATING CONDITIONS

The EUT tested system was configured as the statements of 2.3 Unless otherwise a special operating condition is specified in the follows during the testing.



3.1.5 TEST RESULTS

Note:

All the test modes completed for test. only the worst result of was reported.

EUT :	Camera Detector	Model Name. :	X13
Temperature :	24 °C	Relative Humidity :	54%
Pressure :	1010 hPa	Test Date :	2024-05-07
Test Mode :	Mode 1	Polarization :	L
Test Voltage :	DC 5V From Type-C		

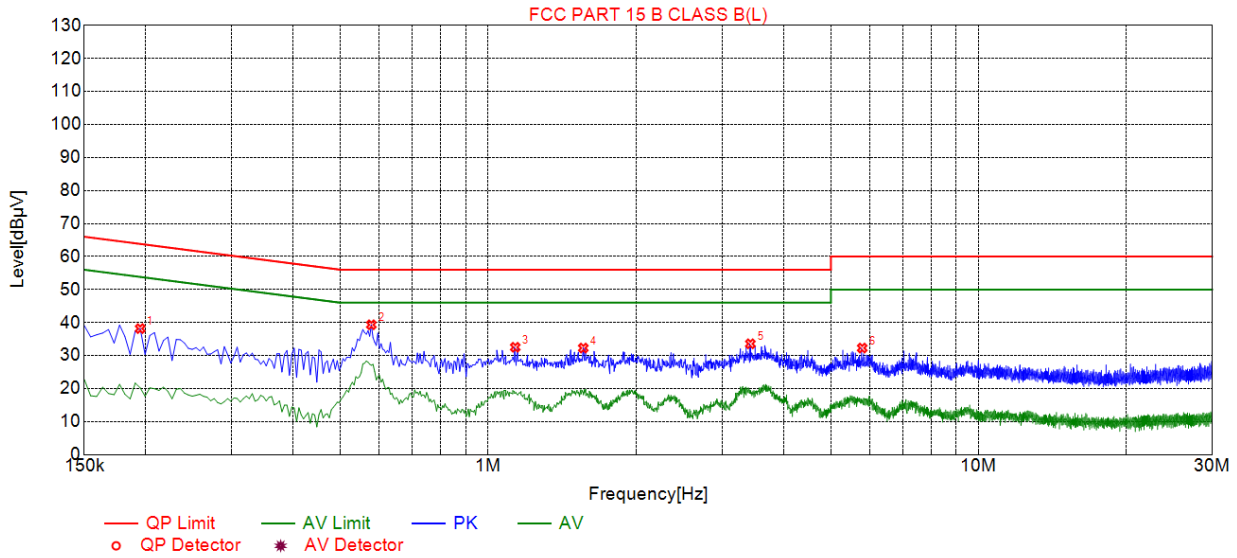

Suspected List								
NO.	Freq. [MHz]	Level [dBµV]	Factor [dB]	Limit [dBµV]	Margin [dB]	Reading [dBµV]	Detector	Type
1	0.1950	38.17	20.03	63.82	25.65	18.14	PK	L
2	0.5775	39.33	20.05	56.00	16.67	19.28	PK	L
3	1.1355	32.52	20.09	56.00	23.48	12.43	PK	L
4	1.5630	32.28	20.11	56.00	23.72	12.17	PK	L
5	3.4280	33.57	20.24	56.00	22.43	13.33	PK	L
6	5.7930	32.28	20.24	60.00	27.72	12.04	PK	L

Remark: Margin = Limit – Level

Correction factor = Cable lose + LISN insertion loss

Level=Test receiver reading + correction factor



EUT :	Camera Detector	Model Name. :	X13
Temperature :	24 °C	Relative Humidity :	54%
Pressure :	1010 hPa	Test Date :	2024-05-07
Test Mode :	Mode 1	Polarization :	N
Test Voltage :	DC 5V From Type-C		

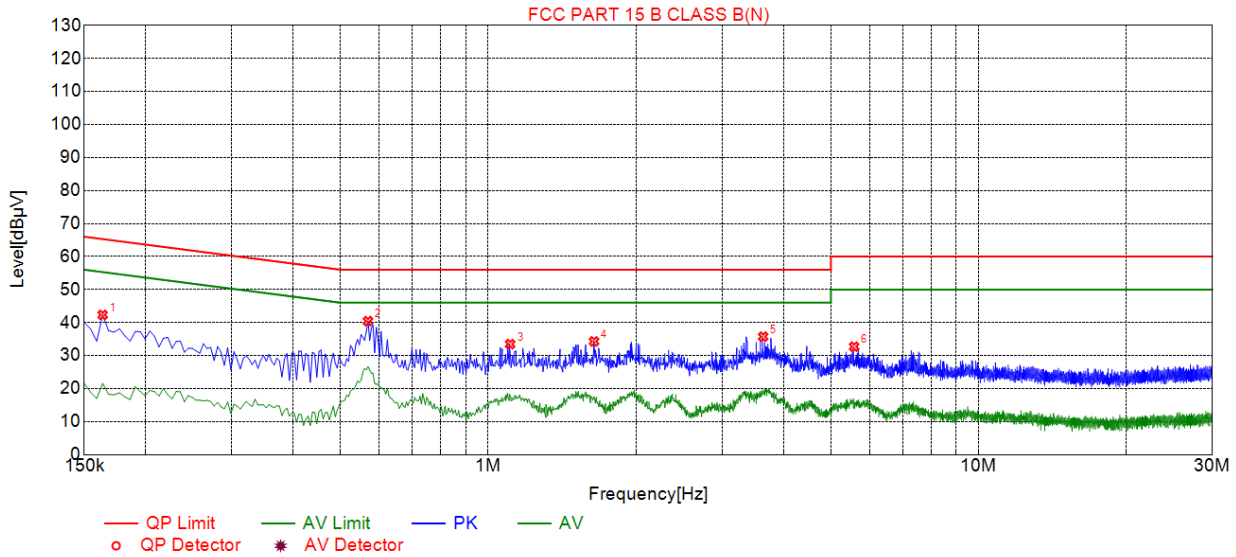

Suspected List								
NO.	Freq. [MHz]	Level [dBµV]	Factor [dB]	Limit [dBµV]	Margin [dB]	Reading [dBµV]	Detector	Type
1	0.1635	42.33	19.98	65.28	22.95	22.35	PK	N
2	0.5685	40.44	20.05	56.00	15.56	20.39	PK	N
3	1.1085	33.47	20.08	56.00	22.53	13.39	PK	N
4	1.6440	34.29	20.12	56.00	21.71	14.17	PK	N
5	3.6375	35.73	20.25	56.00	20.27	15.48	PK	N
6	5.5770	32.69	20.25	60.00	27.31	12.44	PK	N

Remark: Margin = Limit – Level

Correction factor = Cable lose + LISN insertion loss

Level=Test receiver reading + correction factor



3.2 RADIATED EMISSION MEASUREMENT

3.2.1 LIMITS OF RADIATED EMISSION MEASUREMENT

FREQUENCY (MHz)	Class A (at 10m)	Class B (at 3m)
	dBuV/m	dBuV/m
30 ~ 88	39.0	40.0
88 ~ 216	43.5	43.5
216 ~ 960	46.5	46.0
Above 960	49.5	54.0

Notes:

- (1) The limit for radiated test was performed according to as following:
FCC PART 15B /ICES-003.
- (2) The tighter limit applies at the band edges.
- (3) Emission level (dBuV/m)=20log Emission level (uV/m).

3.2.2 TEST PROCEDURE

- a. The measuring distance of at 3 m shall be used for measurements at frequency up to 1GHz. For frequencies above 1GHz, any suitable measuring distance may be used.
- b. The EUT was placed on the top of a rotating table 0.8 meters above the ground at a 3 meter open area test site. The table was rotated 360 degrees to determine the position of the highest radiation.
- c. The height of the equipment or of the substitution antenna shall be 0.8 m; the height of the test antenna shall vary between 1 m to 4 m. Both horizontal and vertical polarizations of the antenna are set to make the measurement.
- d. The initial step in collecting conducted emission data is a spectrum analyzer peak detector mode pre-scanning the measurement frequency range. Significant peaks are then marked and then Quasi Peak detector mode re-measured, above 1G Average detector mode will be instead.
- e. If the Peak Mode measured value compliance with and lower than Quasi Peak Mode Limit, the EUT shall be deemed to meet QP(AV) Limits and then no additional QP Mode measurement performed.
- f. For the actual test configuration, please refer to the related Item –EUT Test Photos.

3.2.3 TEST SETUP

(A) Radiated Emission Test Set-Up Frequency Below 1 GHz

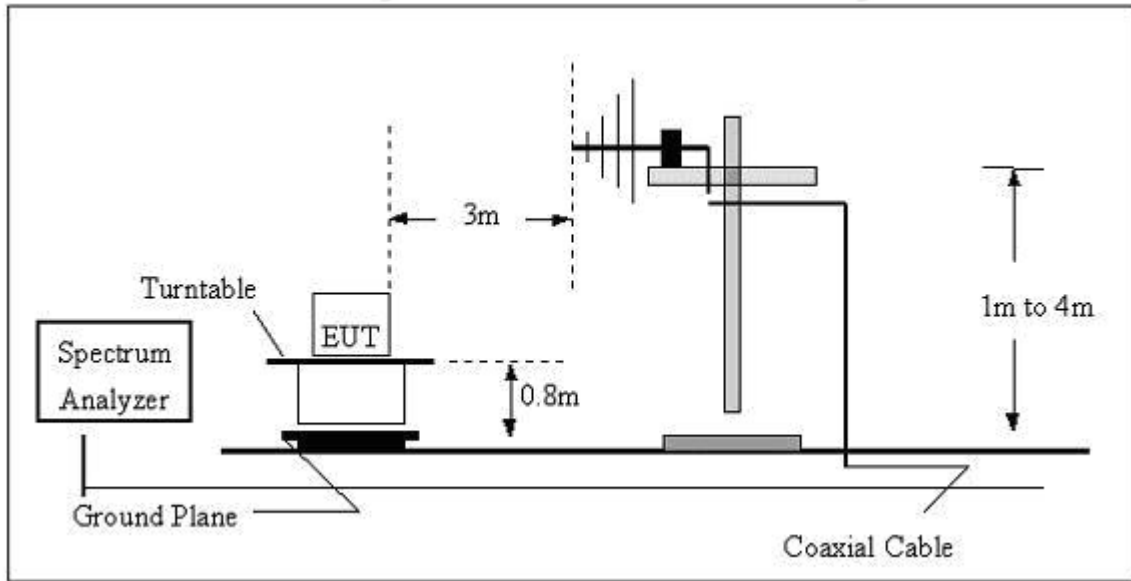

(B) Radiated Emission Test Set-Up Frequency Above 1GHz

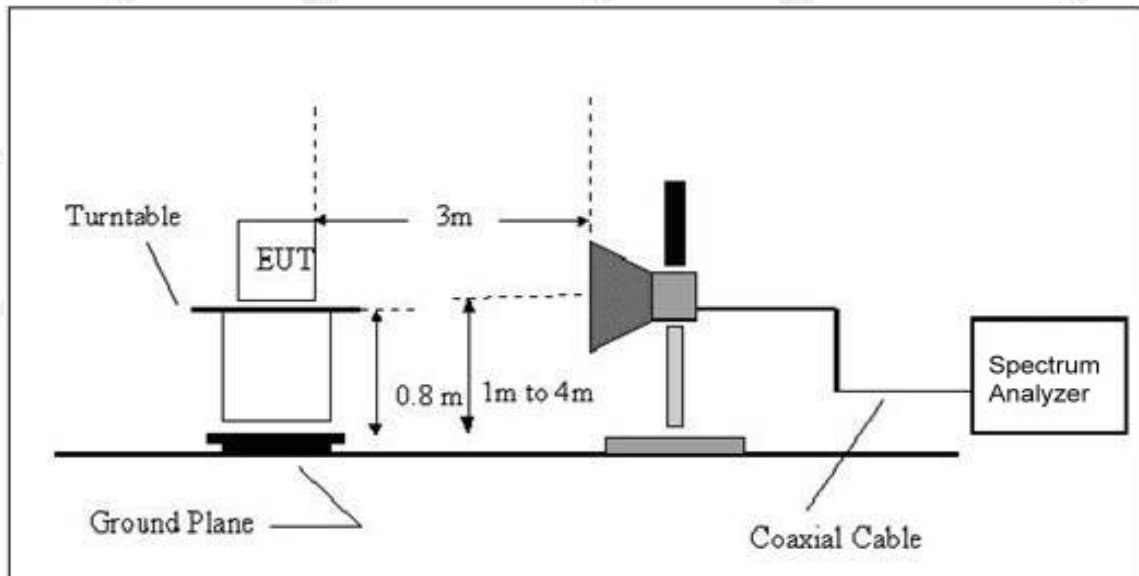

3.2.4 EUT OPERATING CONDITIONS

The EUT tested system was configured as the statements of 2.3 Unless otherwise a special operating condition is specified in the follows during the testing.



3.2.5 TEST RESULTS

Note:

All the test modes completed for test. only the worst result of was reported.

EUT :	Camera Detector	Model Name :	X13
Temperature :	24 °C	Relative Humidity :	54%
Pressure :	1010 hPa	Test Date :	2024-05-07
Test Mode :	Mode 1	Polarization :	Horizontal
Test Power :	DC 5V From Type-C		

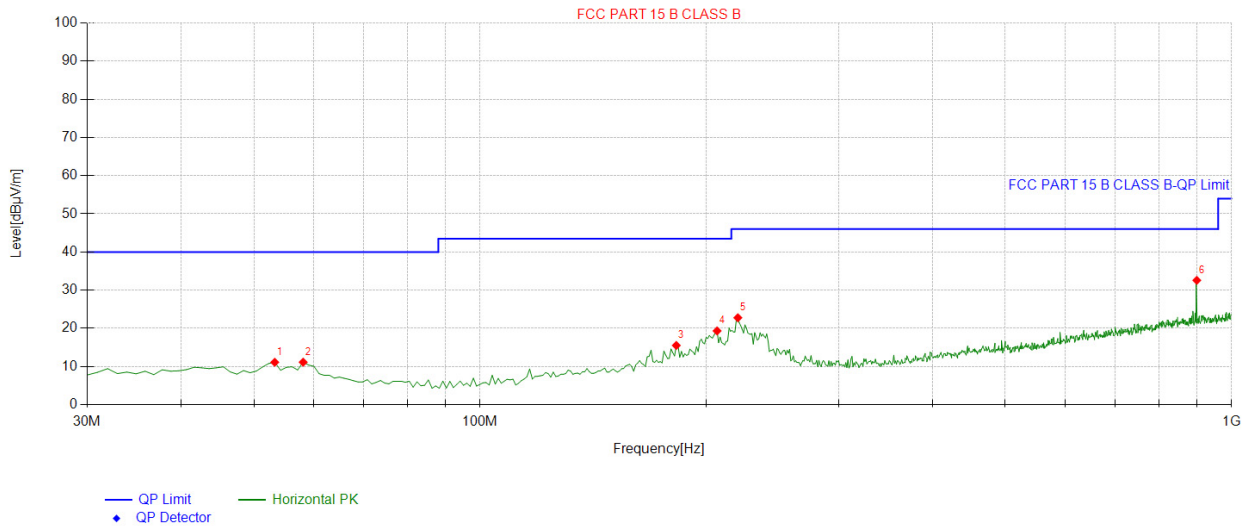

Suspected List									
NO.	Freq. [MHz]	Factor [dB]	Reading [dBµV/m]	Level [dBµV/m]	Limit [dBµV/m]	Margin [dB]	Height [cm]	Angle [°]	Polarity
1	53.303303	-17.52	28.63	11.11	40.00	28.89	100	147	Horizontal
2	58.158158	-18.07	29.21	11.14	40.00	28.86	100	233	Horizontal
3	182.44244	-19.34	34.86	15.52	43.50	27.98	100	167	Horizontal
4	206.71671	-20.49	39.82	19.33	43.50	24.17	100	180	Horizontal
5	220.31031	-20.19	42.96	22.77	46.00	23.23	100	175	Horizontal
6	899.01901	-6.69	39.27	32.58	46.00	13.42	100	296	Horizontal

Remark: Factor = Cable loss + Antenna factor + Attenuator – Preamplifier; Level = Reading + Factor; Margin = Limit – Level;



EUT :	Camera Detector	Model Name :	X13
Temperature :	24 °C	Relative Humidity :	54%
Pressure :	1010 hPa	Test Date :	2024-05-07
Test Mode :	Mode 1	Polarization :	Vertical
Test Power :	DC 5V From Type-C		

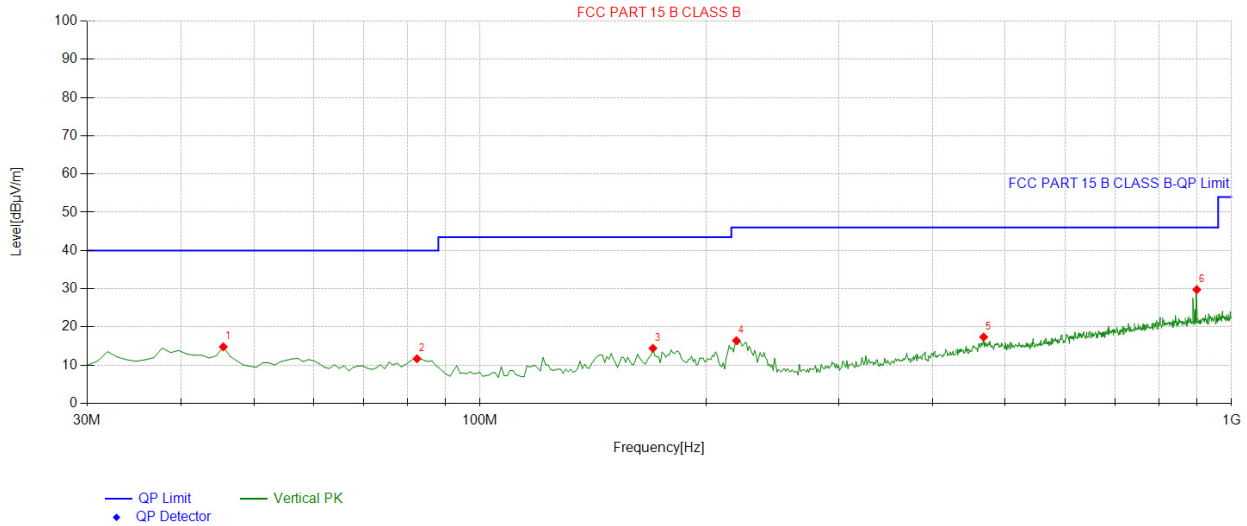

Suspected List									
NO.	Freq. [MHz]	Factor [dB]	Reading [dBµV/m]	Level [dBµV/m]	Limit [dBµV/m]	Margin [dB]	Height [cm]	Angle [°]	Polarity
1	45.535536	-17.20	32.01	14.81	40.00	25.19	100	211	Vertical
2	82.432432	-21.74	33.43	11.69	40.00	28.31	100	316	Vertical
3	169.81982	-17.43	31.86	14.43	43.50	29.07	100	9	Vertical
4	219.33933	-20.22	36.64	16.42	46.00	29.58	100	59	Vertical
5	467.90790	-13.66	31.03	17.37	46.00	28.63	100	231	Vertical
6	899.01901	-6.69	36.47	29.78	46.00	16.22	100	20	Vertical

Remark: Factor = Cable loss + Antenna factor + Attenuator – Preamplifier; Level = Reading + Factor; Margin = Limit – Level;



3.2.6 TEST RESULTS(Above 1GHz)

EUT :	Camera Detector	Model Name :	X13
Temperature :	24 °C	Relative Humidity :	54%
Pressure :	1010 hPa	Test Date :	2024-05-07
Test Mode :	Mode 3	Polarization :	Horizontal
Test Power :	DC3.7V from battery		

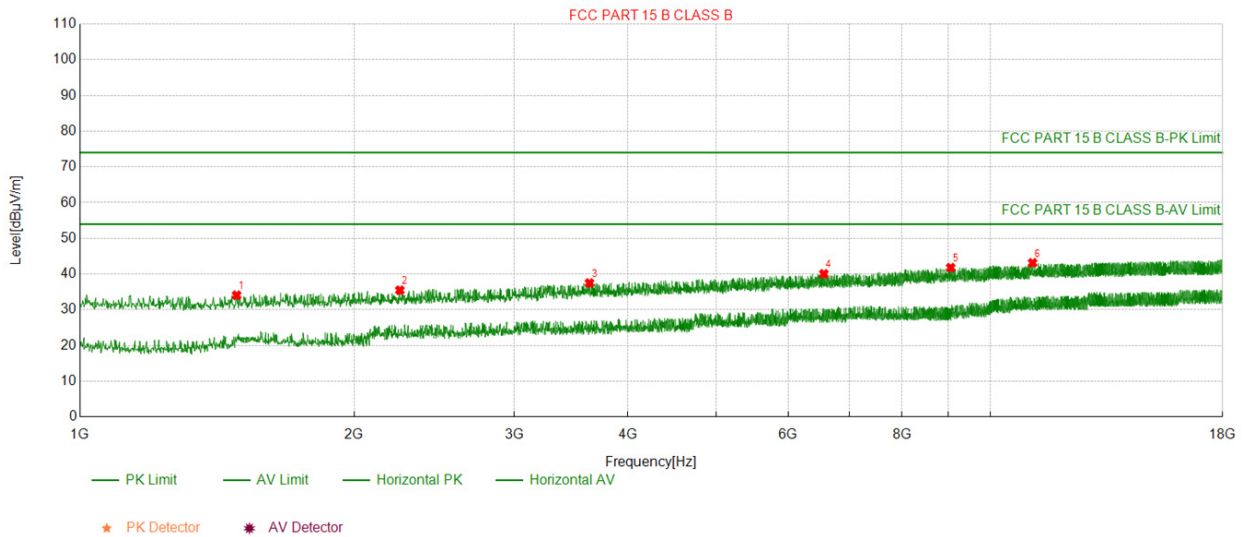

Suspected List									
NO.	Freq. [MHz]	Factor [dB]	Reading [dBµV/m]	Level [dBµV/m]	Limit [dBµV/m]	Margin [dB]	Height [cm]	Angle [°]	Polarity
1	1486.2486	-20.45	54.52	34.07	74.00	39.93	100	170	Horizontal
2	2246.2246	-17.68	53.15	35.47	74.00	38.53	100	80	Horizontal
3	3628.4628	-13.41	50.89	37.48	74.00	36.52	100	290	Horizontal
4	6564.6564	-6.73	46.79	40.06	74.00	33.94	100	140	Horizontal
5	9046.9046	-2.10	43.88	41.78	74.00	32.22	100	160	Horizontal
6	11129.612	1.34	41.79	43.13	74.00	30.87	100	90	Horizontal

Remark: Factor = Cable loss + Antenna factor + Attenuator – Preamplifier; Level = Reading + Factor; Margin = Limit – Level;



EUT :	Camera Detector	Model Name :	X13
Temperature :	24 °C	Relative Humidity :	54%
Pressure :	1010 hPa	Test Date :	2024-05-07
Test Mode :	Mode 3	Polarization :	Vertical
Test Power :	DC3.7V from battery		

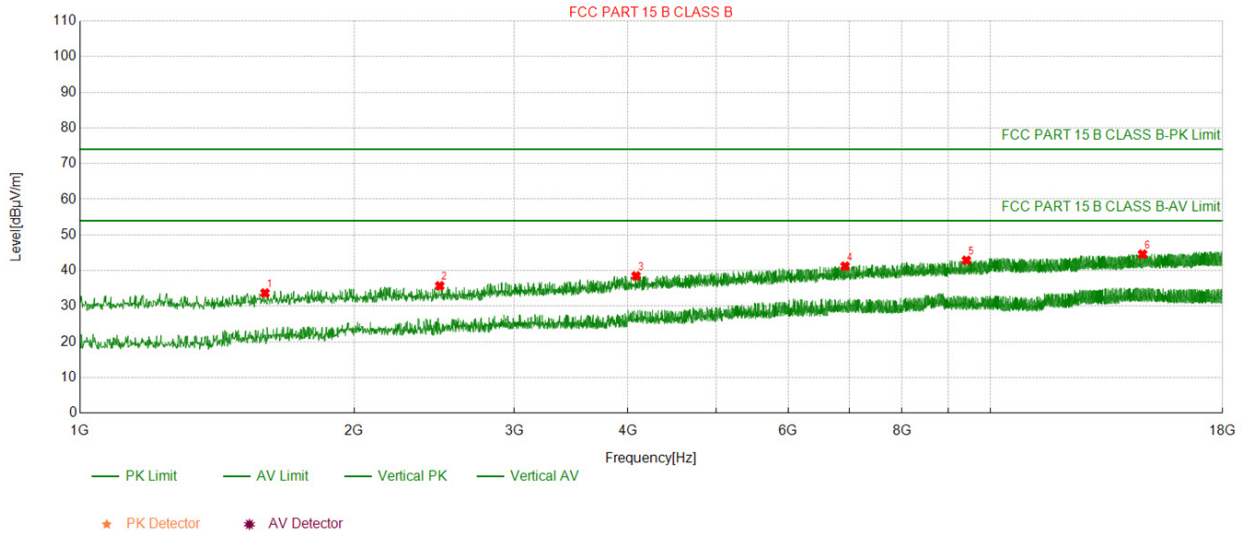

Suspected List									
NO.	Freq. [MHz]	Factor [dB]	Reading [dBµV/m]	Level [dBµV/m]	Limit [dBµV/m]	Margin [dB]	Height [cm]	Angle [°]	Polarity
1	1596.7596	-20.49	54.18	33.69	74.00	40.31	100	130	Vertical
2	2484.2484	-16.74	52.44	35.70	74.00	38.30	100	230	Vertical
3	4082.4082	-12.05	50.51	38.46	74.00	35.54	100	190	Vertical
4	6926.7926	-5.56	46.76	41.20	74.00	32.80	100	40	Vertical
5	9414.1414	-1.66	44.52	42.86	74.00	31.14	100	210	Vertical
6	14699.969	5.88	38.70	44.58	74.00	29.42	100	160	Vertical

Remark: Factor = Cable loss + Antenna factor + Attenuator – Preamplifier; Level = Reading + Factor; Margin = Limit – Level;



4. EUT TEST PHOTOS

Radiated Emission

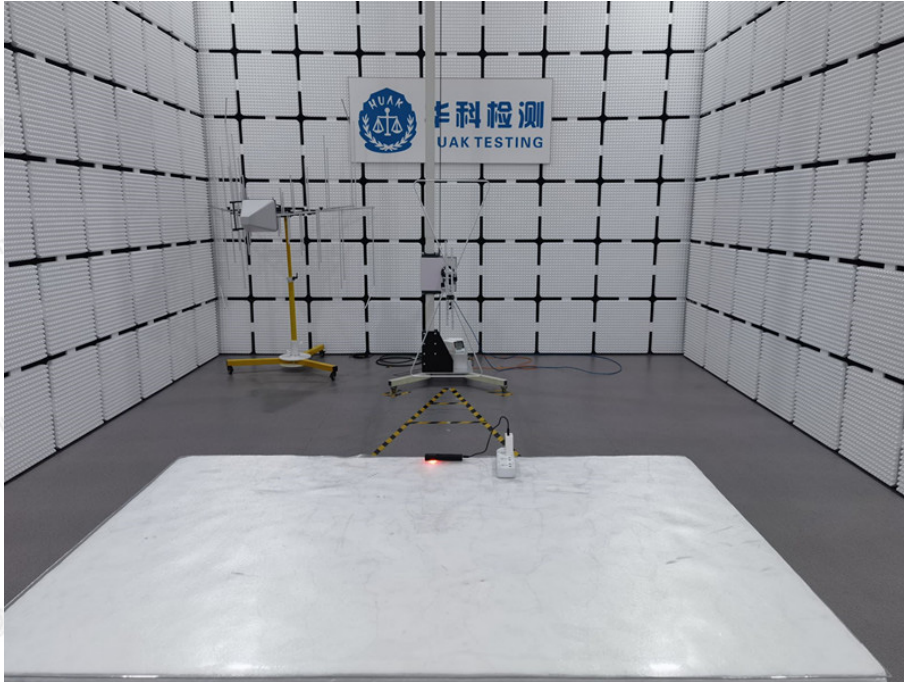

The results shown in this test report refer only to the sample(s) tested unless otherwise stated and the sample(s) are retained for 30 days only. The document is issued by HUAK, this document cannot be reproduced except in full with our prior written permission. The more details and the authenticity of the report will be confirmed at <http://www.cer-mark.com>.

TEL : +86-755 2302 9901 FAX : +86-755 2302 9901 E-mail : service@cer-mark.com

Addr: 1-2F., Building B2, Junfeng Zhongcheng Zhizao Innovation Park, Heping Community, Fuhai Street, Bao'an District, Shenzhen, Guangdong, China



Conducted Emission

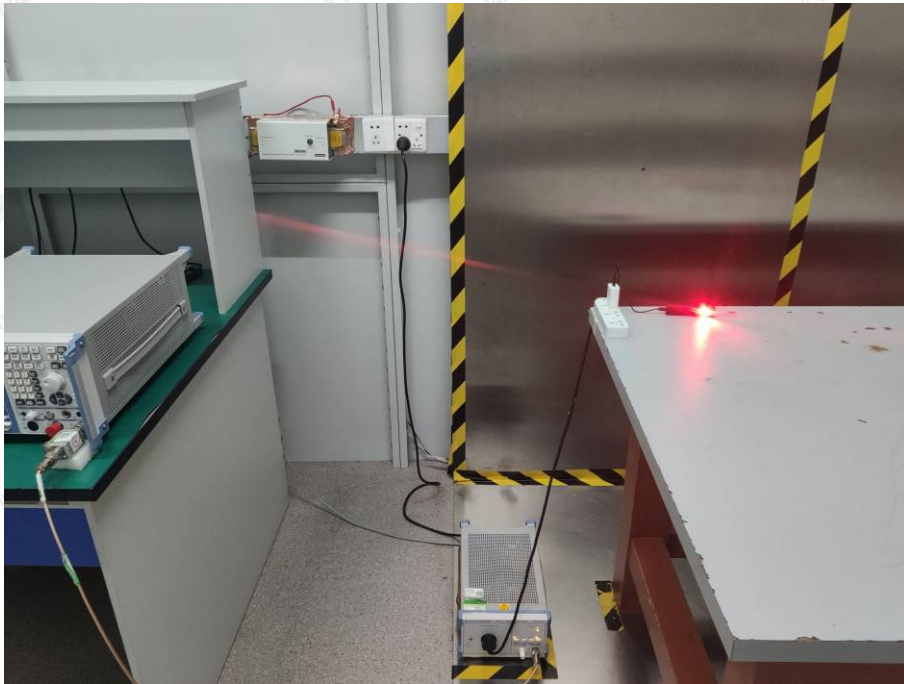

The results shown in this test report refer only to the sample(s) tested unless otherwise stated and the sample(s) are retained for 30 days only. The document is issued by HUAK, this document cannot be reproduced except in full with our prior written permission. The more details and the authenticity of the report will be confirmed at <http://www.cer-mark.com>.

TEL : +86-755 2302 9901 FAX : +86-755 2302 9901 E-mail : service@cer-mark.com

Addr: 1-2F., Building B2, Junfeng Zhongcheng Zhizao Innovation Park, Heping Community, Fuhai Street, Bao'an District, Shenzhen, Guangdong, China



ATTACHMENT PHOTOGRAPHS OF EUT

Photo 1



Photo 2





Photo 3

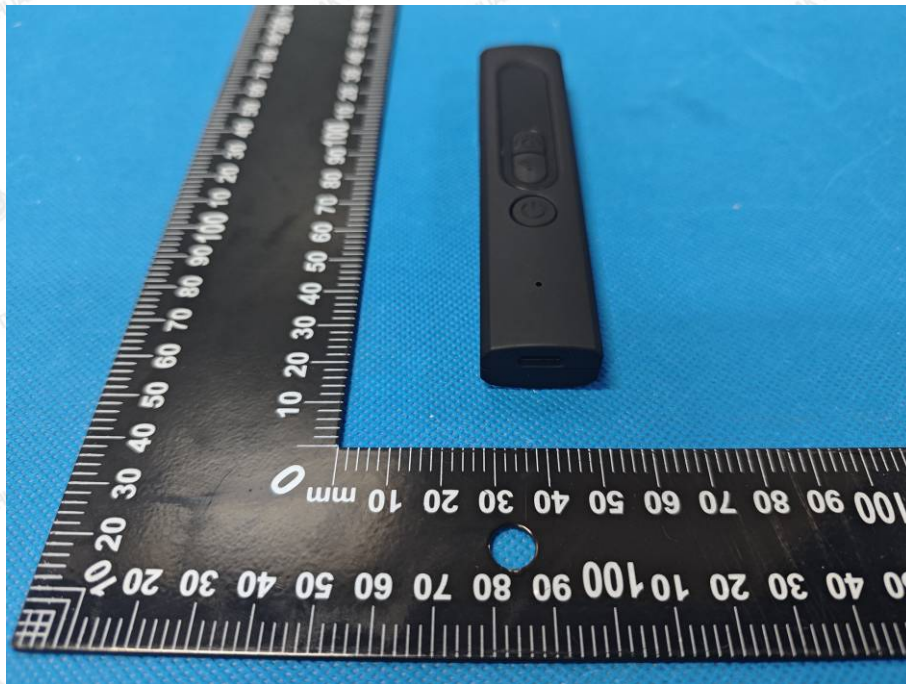

Photo 4





Photo 5



Photo 6





Photo 7



Photo 8

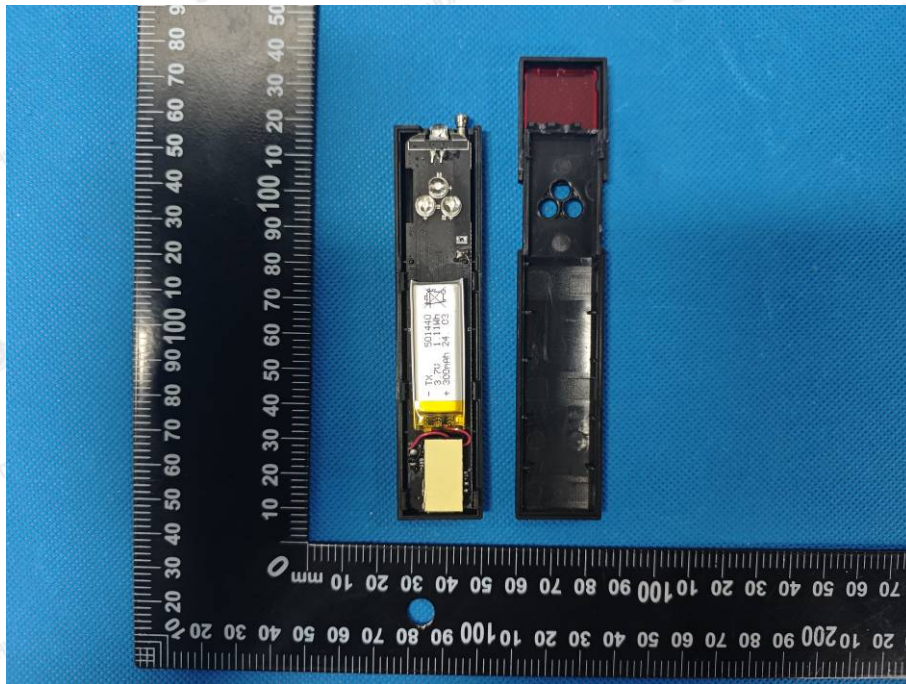



Photo 9

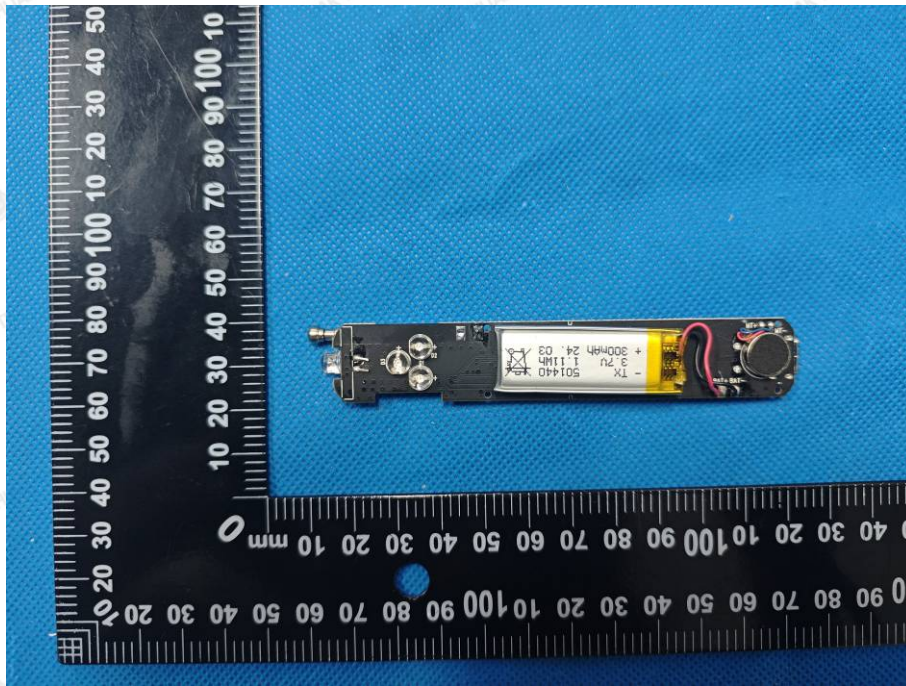
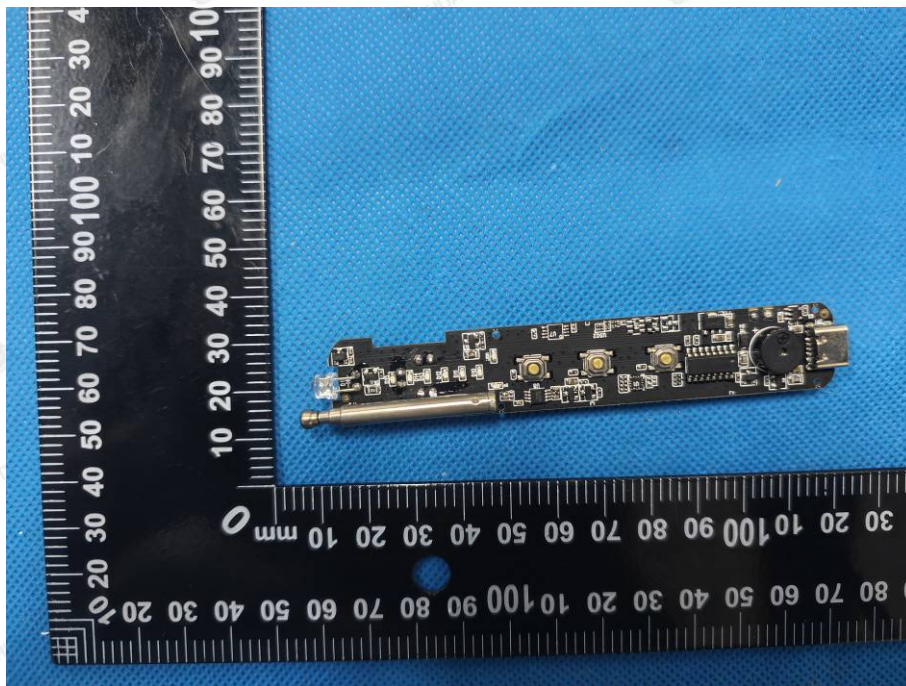

Photo 10



-----End of report-----