



# RF TEST REPORT

For

**Guangdong Sanenshi Intelligent Technology Co., Ltd.**

**Product Name: Benchtop Spectrophotometers**

**Model(s): TS8500**

**Report Reference No.** : POCE230803052BRW

**FCC ID** : 2BCI9-TS8500

**Applicant's Name** : Guangdong Sanenshi Intelligent Technology Co., Ltd.

**Address** : 6-8/F, Building B33, Low-Carbon Headquarters Park, 400 Xincheng Avenue, Zengcheng District, Guangzhou, P.R. China.

**Testing Laboratory** : Shenzhen POCE Technology Co., Ltd.

**Address** : 102 Building H1 & 1/F., Building H, Hongfa Science & Technology Park, Tangtou, Shiyuan, Bao'an District, Shenzhen, Guangdong, China

**Test Specification Standard** : 47 CFR Part 15.247

**Date of Receipt** : August 3, 2023

**Date of Test** : August 3, 2023 to August 17, 2023

**Date of Issue** : August 17, 2023

**Result** : Pass

Note: This report shall not be reproduced except in full, without the written approval of Shenzhen POCE Technology Co., Ltd. This document may be altered or revised by Shenzhen POCE Technology Co., Ltd. personnel only, and shall be noted in the revision section of the document. The test results in the report only apply to the tested sample



## Revision History Of Report

Version	Description	REPORT No.	Issue Date
V1.0	Original	POCE230803052BRW	August 17, 2023

**NOTE1:**

The manufacturer should ensure that all products in series production are in conformity with the product sample detailed in this report. If the product in this report is used in any configuration other than that detailed in the report, the manufacturer must ensure the new system complies with all relevant standards.

Compiled by:

Amy Zhu / File administrators

Supervised by:

Stone Yin / Technique principal

Approved by:

Machael Mo / Manager

# CONTENTS

<b>1 TEST SUMMARY</b> .....	<b>5</b>
1.1 TEST STANDARDS .....	5
1.2 SUMMARY OF TEST RESULT .....	5
<b>2 GENERAL INFORMATION</b> .....	<b>6</b>
2.1 CLIENT INFORMATION .....	6
2.2 DESCRIPTION OF DEVICE (EUT) .....	6
2.3 DESCRIPTION OF TEST MODES .....	7
2.4 DESCRIPTION OF SUPPORT UNITS .....	7
2.5 EQUIPMENTS USED DURING THE TEST .....	7
2.6 STATEMENT OF THE MEASUREMENT UNCERTAINTY .....	9
2.7 IDENTIFICATION OF TESTING LABORATORY .....	9
2.8 ANNOUNCEMENT .....	9
<b>3 EVALUATION RESULTS (EVALUATION)</b> .....	<b>10</b>
3.1 ANTENNA REQUIREMENT .....	10
3.1.1 Conclusion: .....	10
<b>4 RADIO SPECTRUM MATTER TEST RESULTS (RF)</b> .....	<b>11</b>
4.1 CONDUCTED EMISSION AT AC POWER LINE .....	11
4.1.1 E.U.T. Operation: .....	11
4.1.2 Test Setup Diagram: .....	11
4.1.3 Test Data: .....	12
4.2 OCCUPIED BANDWIDTH .....	14
4.2.1 E.U.T. Operation: .....	14
4.2.2 Test Setup Diagram: .....	14
4.2.3 Test Data: .....	14
4.3 MAXIMUM CONDUCTED OUTPUT POWER .....	15
4.3.1 E.U.T. Operation: .....	15
4.3.2 Test Setup Diagram: .....	15
4.3.3 Test Data: .....	15
4.4 POWER SPECTRAL DENSITY .....	16
4.4.1 E.U.T. Operation: .....	16
4.4.2 Test Setup Diagram: .....	16
4.4.3 Test Data: .....	16
4.5 EMISSIONS IN NON-RESTRICTED FREQUENCY BANDS .....	17
4.5.1 E.U.T. Operation: .....	17
4.5.2 Test Setup Diagram: .....	17
4.5.3 Test Data: .....	17
4.6 BAND EDGE EMISSIONS (RADIATED) .....	18
4.6.1 E.U.T. Operation: .....	18
4.6.2 Test Setup Diagram: .....	18
4.6.3 Test Data: .....	19
4.7 EMISSIONS IN RESTRICTED FREQUENCY BANDS (BELOW 1GHZ) .....	23
4.7.1 E.U.T. Operation: .....	24
4.7.2 Test Data: .....	25
4.8 EMISSIONS IN RESTRICTED FREQUENCY BANDS (ABOVE 1GHZ) .....	27
4.8.1 E.U.T. Operation: .....	28
4.8.2 Test Setup Diagram: .....	28
4.8.3 Test Data: .....	29
<b>5 TEST SETUP PHOTOS</b> .....	<b>35</b>
<b>6 PHOTOS OF THE EUT</b> .....	<b>35</b>



**APPENDIX** ..... 36

1. -6DB BANDWIDTH ..... 37

2. BANEDGE ..... 40

3. PEAK OUTPUT POWER ..... 44

4. POWER SPECTRAL DENSITY ..... 47

5. SPURIOUS EMISSION ..... 50



# 1 TEST SUMMARY

## 1.1 Test Standards

The tests were performed according to following standards:

**47 CFR Part 15.247:** Operation within the bands 902-928 MHz, 2400-2483.5 MHz, and 5725-5850 MHz

## 1.2 Summary of Test Result

Item	Standard	Method	Requirement	Result
Antenna requirement	47 CFR Part 15.247		47 CFR 15.203	Pass
Conducted Emission at AC power line	47 CFR Part 15.247	ANSI C63.10-2013 section 6.2	47 CFR 15.207(a)	Pass
Occupied Bandwidth	47 CFR Part 15.247	ANSI C63.10-2013, section 11.8 KDB 558074 D01 15.247 Meas Guidance v05r02	47 CFR 15.247(a)(2)	Pass
Maximum Conducted Output Power	47 CFR Part 15.247	ANSI C63.10-2013, section 11.9.1 KDB 558074 D01 15.247 Meas Guidance v05r02	47 CFR 15.247(b)(3)	Pass
Power Spectral Density	47 CFR Part 15.247	ANSI C63.10-2013, section 11.10 KDB 558074 D01 15.247 Meas Guidance v05r02	47 CFR 15.247(e)	Pass
Emissions in non-restricted frequency bands	47 CFR Part 15.247	ANSI C63.10-2013 section 11.11 KDB 558074 D01 15.247 Meas Guidance v05r02	47 CFR 15.247(d)	Pass
Band edge emissions (Radiated)	47 CFR Part 15.247	ANSI C63.10-2013 section 6.10 KDB 558074 D01 15.247 Meas Guidance v05r02	47 CFR 15.247(d)	Pass
Emissions in restricted frequency bands (below 1GHz)	47 CFR Part 15.247	ANSI C63.10-2013 section 6.6.4 KDB 558074 D01 15.247 Meas Guidance v05r02	47 CFR 15.247(d)	Pass
Emissions in restricted frequency bands (above 1GHz)	47 CFR Part 15.247	ANSI C63.10-2013 section 6.6.4 KDB 558074 D01 15.247 Meas Guidance v05r02	47 CFR 15.247(d)	Pass

## 2 GENERAL INFORMATION

### 2.1 Client Information

**Applicant's Name** : Guangdong Sanenshi Intelligent Technology Co., Ltd.  
**Address** : 6-8/F,Building B33,Low-Carbon Headquarters Park,400 Xincheng Avenue,Zengcheng District,Guangzhou,P.R.China.

**Manufacturer** : Guangdong Sanenshi Intelligent Technology Co., Ltd.  
**Address** : 6-8/F,Building B33,Low-Carbon Headquarters Park,400 Xincheng Avenue,Zengcheng District,Guangzhou,P.R.China.

### 2.2 Description of Device (EUT)

Product Name:	Benchtop Spectrophotometers
Model/Type reference:	TS8500
Series Model:	TS8500S, TS8510, TS8520, TS8560
Model Difference:	The product has many models, only the model name is different, and the other parts such as the circuit principle, pcb and electrical structure are the same.
Trade Mark:	N/A
Power Supply:	DC24V/3A/Power from Adapter
Power Adaptor:	MODEL:B06240300 INPOU:100-240VAC 50/60Hz 1.5A Max OUTPUT:DC24V/3A
Operation Frequency:	2402MHz to 2480MHz
Number of Channels:	40
Modulation Type:	GFSK
Antenna Type:	Ceramic Antenna
Antenna Gain:	1.34 dBi
Sample number:	230803003
Hardware Version:	V1.0
Software Version:	V1.0

#### Operation Frequency each of channel

Channel	Frequency	Channel	Frequency	Channel	Frequency	Channel	Frequency
1	2402 MHz	11	2422 MHz	21	2442 MHz	31	2462 MHz
2	2404 MHz	12	2424 MHz	22	2444 MHz	32	2464 MHz
3	2406 MHz	13	2426 MHz	23	2446 MHz	33	2466 MHz
4	2408 MHz	14	2428 MHz	24	2448 MHz	34	2468 MHz
5	2410 MHz	15	2430 MHz	25	2450 MHz	35	2470 MHz
6	2412 MHz	16	2432 MHz	26	2452 MHz	36	2472 MHz
7	2414 MHz	17	2434 MHz	27	2454 MHz	37	2474 MHz
8	2416 MHz	18	2436 MHz	28	2456 MHz	38	2476 MHz
9	2418 MHz	19	2438 MHz	29	2458 MHz	39	2478 MHz
10	2420 MHz	20	2440 MHz	30	2460 MHz	40	2480 MHz

Note:

In section 15.31(m), regards to the operating frequency range over 10 MHz, the Lowest frequency, the middle frequency, and the highest frequency of channel were selected to perform the test, and the selected channel see below:

Test channel	Frequency (MHz)
	BLE
Lowest channel	2402MHz
Middle channel	2440MHz
Highest channel	2480MHz

### 2.3 Description of Test Modes

No	Title	Description
TM1	Lowest channel	Keep the EUT works in continuously transmitting mode with GFSK modulation.(Duty cycle>=98%)
TM2	Middle channel	Keep the EUT works in continuously transmitting mode with GFSK modulation.(Duty cycle>=98%)
TM3	Highest channel	Keep the EUT works in continuously transmitting mode with GFSK modulation.(Duty cycle>=98%)
Remark:Only the data of the worst mode would be recorded in this report.		

### 2.4 Description of Support Units

The EUT was tested as an independent device.

### 2.5 Equipments Used During The Test

Conducted Emission at AC power line					
Equipment	Manufacturer	Model No	Inventory No	Cal Date	Cal Due Date
loop antenna	EVERFINE	LLA-2	80900L-C	2023-02-27	2024-02-26
Power absorbing clamp	SCHWARZ BECK	MESS-ELEKTRONIK	/	2023-02-28	2024-02-27
Electric Network	SCHWARZ BECK	CAT5 8158	CAT5 8158#207	/	/
Cable	SCHWARZ BECK	/	/	2022-12-27	2023-12-27
Pulse Limiter	SCHWARZ BECK	VTSD 9561-F Pulse limiter 10dB Ateennator	561-G071	2023-02-27	2024-02-26
50ΩCoaxial Switch	Anritsu	MP59B	M20531	/	/
Test Receiver	Rohde & Schwarz	ESPI TEST RECEIVER	ID:1164.6607 K03-102109-MH	2023-06-13	2024-06-12
L.I.S.N	R&S	ESH3-Z5	831.5518.52	2022-12-29	2023-12-28



**Maximum Conducted Output Power  
Power Spectral Density  
Emissions in non-restricted frequency bands  
Occupied Bandwidth**

Equipment	Manufacturer	Model No	Inventory No	Cal Date	Cal Due Date
RF Test Software	TACHOY	RTS-01	V2.0.0.0	/	/
High Pass filter	ZHINAN	OQHPF1-M1.5-18G-224	6210075	/	/
Power divider	MIDEWEST	PWD-2533	SMA-79	2023-05-11	2026-05-10
DC power	HP	66311B	38444359	/	/
RF Sensor Unit	Tachoy Information Technology(she n zhen) Co.,Ltd.	TR1029-2	000001	/	/
Wideband radio communication tester	R&S	CMW500	113410	2023-06-13	2024-06-12
Vector signal generator	Keysight	N5181A	MY48180415	2022-12-10	2023-12-09
Signal generator	Keysight	N5182A	MY50143455	2022-12-29	2023-12-28
Spectrum Analyzer	Keysight	N9020A	MY53420323	2022-12-29	2023-12-28

**Band edge emissions (Radiated)  
Emissions in restricted frequency bands (below 1GHz)  
Emissions in restricted frequency bands (above 1GHz)**

Equipment	Manufacturer	Model No	Inventory No	Cal Date	Cal Due Date
EMI Test software	Farad	EZ -EMC	V1.1.42	/	/
Positioning Controller	/	MF-7802	/	/	/
High Pass filter	ZHINAN	OQHPF1-M1.5-18G-224	6210075	/	/
Amplifier(18-40G)	COM-POWER	AH-1840	10100008-1	2022-04-05	2025-04-04
Horn antenna	COM-POWER	AH-1840 (18-40G)	10100008	2023-04-05	2025-04-04
Loop antenna	ZHINAN	ZN30900C	ZN30900C	2021-07-05	2024-07-04
Cable(LF)#2	Schwarzbeck	/	/	2023-02-27	2024-02-26
Cable(LF)#1	Schwarzbeck	/	/	2023-02-27	2024-02-26
Cable(HF)#2	Schwarzbeck	AK9515E	96250	2023-02-28	2024-02-27
Cable(HF)#1	Schwarzbeck	SYV-50-3-1	/	2023-02-27	2024-02-26
Power amplifier(LF)	Schwarzbeck	BBV9743	9743-151	2023-06-13	2024-06-12
Power amplifier(HF)	Schwarzbeck	BBV9718	9718-282	2023-06-13	2024-06-12
Wideband radio communication tester	R&S	CMW500	113410	2023-06-13	2024-06-12
Spectrum Analyzer	R&S	FSP30	1321.3008K40-101729-jR	2023-06-14	2024-06-13
Horn Antenna	Sunol Sciences	DRH-118	A091114	2023-05-13	2025-05-12
Broadband Antenna	Sunol Sciences	JB6 Antenna	A090414	2023-05-21	2025-05-20
Test Receiver	R&S	ESCI	102109	2023-06-13	2024-06-12



## 2.6 Statement Of The Measurement Uncertainty

Test Item	Measurement Uncertainty
Conducted Disturbance (0.15~30MHz)	±3.41dB
Occupied Bandwidth	±3.63%
RF conducted power	±0.733dB
RF power density	±0.234%
Conducted Spurious emissions	±1.98dB
Radiated Emission (Above 1GHz)	±5.46dB
Radiated Emission (Below 1GHz)	±5.79dB

Note: (1) This uncertainty represents an expanded uncertainty expressed at approximately the 95% confidence level using a coverage factor of k=2.

## 2.7 Identification of Testing Laboratory

Company Name:	Shenzhen POCE Technology Co., Ltd.
Address:	101-102 Building H5 & 1/F., Building H, Hongfa Science & Technology Park, Tangtou, Shiyan, Bao'an District, Shenzhen, Guangdong, China
Phone Number:	+86-13267178997
Fax Number:	86-755-29113252

### Identification of the Responsible Testing Location

Company Name:	Shenzhen POCE Technology Co., Ltd.
Address:	101-102 Building H5 & 1/F., Building H, Hongfa Science & Technology Park, Tangtou, Shiyan, Bao'an District, Shenzhen, Guangdong, China
Phone Number:	+86-13267178997
Fax Number:	86-755-29113252
FCC Registration Number:	0032847402
Designation Number:	CN1342
Test Firm Registration Number:	778666
A2LA Certificate Number:	6270.01

## 2.8 Announcement

- (1) The test report reference to the report template version v0.
- (2) The test report is invalid if not marked with the signatures of the persons responsible for preparing, reviewing and approving the test report.
- (3) The test report is invalid if there is any evidence and/or falsification.
- (4) This document may not be altered or revised in any way unless done so by POCE and all revisions are duly noted in the revisions section.
- (5) Content of the test report, in part or in full, cannot be used for publicity and/or promotional purposes without prior written approval from the laboratory.
- (6) The laboratory is only responsible for the data released by the laboratory, except for the part provided by the applicant.

### 3 Evaluation Results (Evaluation)

#### 3.1 Antenna requirement

Test Requirement:	An intentional radiator shall be designed to ensure that no antenna other than that furnished by the responsible party shall be used with the device. The use of a permanently attached antenna or of an antenna that uses a unique coupling to the intentional radiator shall be considered sufficient to comply with the provisions of this section.
-------------------	--------------------------------------------------------------------------------------------------------------------------------------------------------------------------------------------------------------------------------------------------------------------------------------------------------------------------------------------------------

##### 3.1.1 Conclusion:

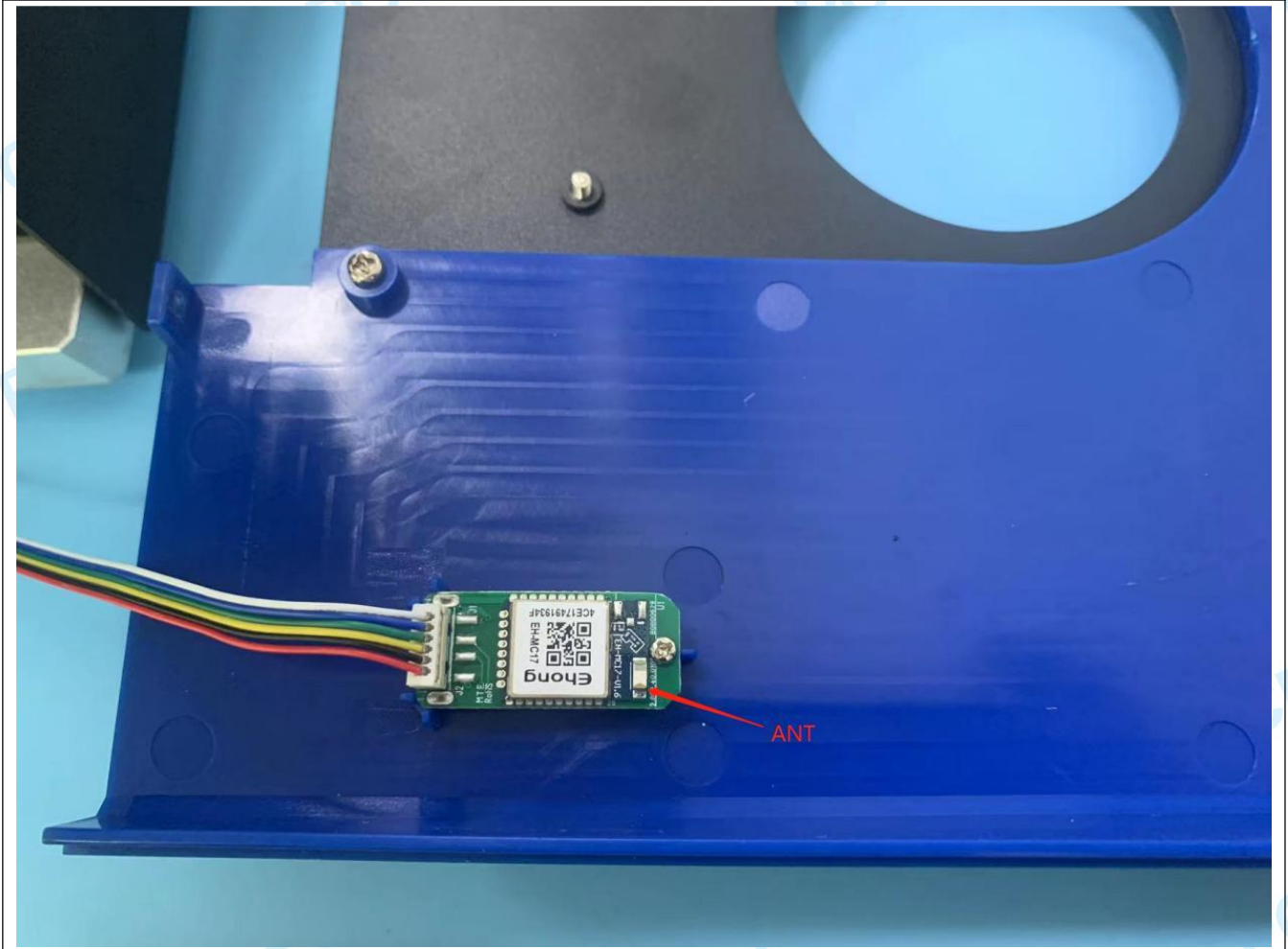

## 4 Radio Spectrum Matter Test Results (RF)

### 4.1 Conducted Emission at AC power line

Test Requirement:	Refer to 47 CFR 15.207(a), Except as shown in paragraphs (b) and (c) of this section, for an intentional radiator that is designed to be connected to the public utility (AC) power line, the radio frequency voltage that is conducted back onto the AC power line on any frequency or frequencies, within the band 150 kHz to 30 MHz, shall not exceed the limits in the following table, as measured using a 50 μH/50 ohms line impedance stabilization network (LISN).		
Test Limit:	Frequency of emission (MHz)	Conducted limit (dBμV)	
		Quasi-peak	Average
	0.15-0.5	66 to 56*	56 to 46*
	0.5-5	56	46
	5-30	60	50
	*Decreases with the logarithm of the frequency.		
Test Method:	ANSI C63.10-2013 section 6.2		
Procedure:	Refer to ANSI C63.10-2013 section 6.2, standard test method for ac power-line conducted emissions from unlicensed wireless devices		

#### 4.1.1 E.U.T. Operation:

Operating Environment:					
Temperature:	23.4 °C	Humidity:	50.8 %	Atmospheric Pressure:	101 kPa
Pre test mode:	TM1				
Final test mode:	TM1				

#### 4.1.2 Test Setup Diagram:

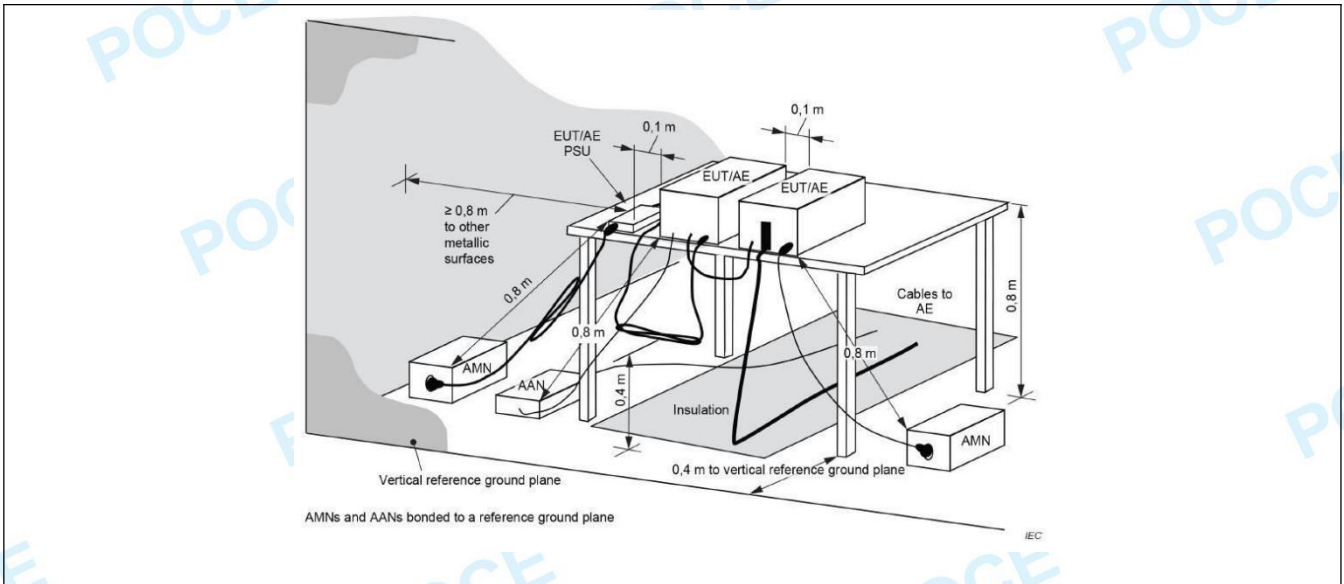



**4.1.3 Test Data:**

TM1 / Line: Line / Band: 2.4G / BW: 1 / CH: L  
 Power: AC120V60Hz

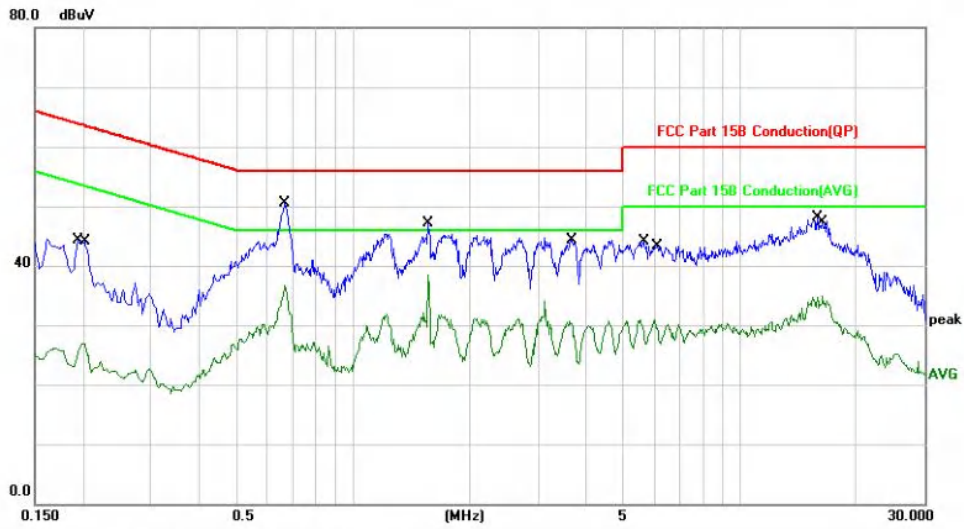

No. Mk.	Freq. MHz	Reading Level dBuV	Correct Factor dB	Measurement dBuV	Limit dBuV	Over dB	Detector	Comment
1	0.1940	23.55	20.71	44.26	63.86	-19.60	QP	
2	0.2020	6.21	20.74	26.95	53.52	-26.57	AVG	
3 *	0.6660	29.86	20.66	50.52	56.00	-5.48	QP	
4	0.6660	16.00	20.66	36.66	46.00	-9.34	AVG	
5	1.5660	26.38	20.75	47.13	56.00	-8.87	QP	
6	1.5660	17.65	20.75	38.40	46.00	-7.60	AVG	
7	3.6380	9.83	20.83	30.66	46.00	-15.34	AVG	
8	3.6660	23.56	20.83	44.39	56.00	-11.61	QP	
9	5.6380	22.97	21.08	44.05	60.00	-15.95	QP	
10	6.0460	9.84	21.13	30.97	50.00	-19.03	AVG	
11	15.8420	25.29	22.79	48.08	60.00	-11.92	QP	
12	16.3380	11.96	22.87	34.83	50.00	-15.17	AVG	



TM1 / Line: Neutral / Band: 2.4G / BW: 1 / CH: L  
 Power: AC120V60Hz

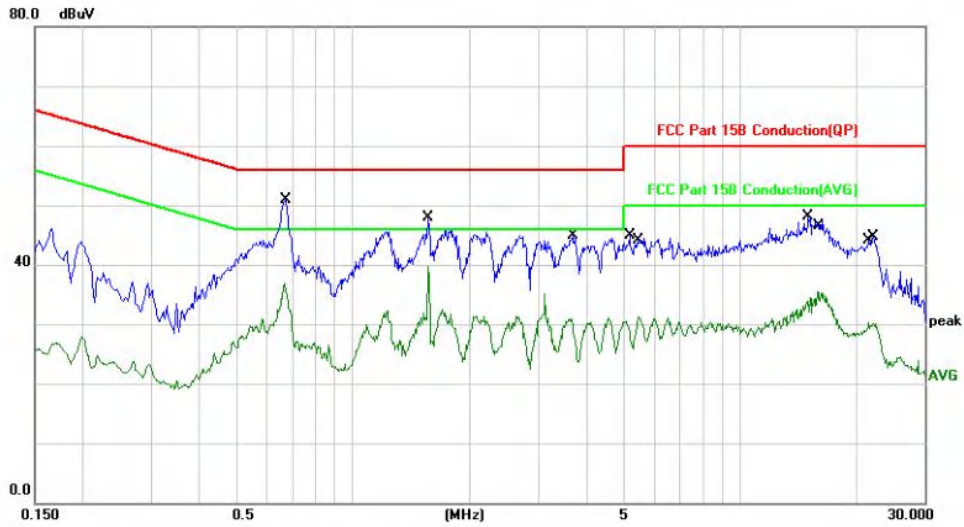

No. Mk.	Freq. MHz	Reading Level dBuV	Correct Factor dB	Measurement dBuV	Limit dBuV	Over dB	Detector	Comment
1	0.6660	16.25	20.66	36.91	46.00	-9.09	AVG	
2 *	0.6700	30.14	20.67	50.81	56.00	-5.19	QP	
3	1.5660	27.25	20.75	48.00	56.00	-8.00	QP	
4	1.5660	18.96	20.75	39.71	46.00	-6.29	AVG	
5	3.6700	10.08	20.83	30.91	46.00	-15.09	AVG	
6	3.6900	24.11	20.83	44.94	56.00	-11.06	QP	
7	5.1700	23.79	21.01	44.80	60.00	-15.20	QP	
8	5.4740	10.23	21.05	31.28	50.00	-18.72	AVG	
9	15.0580	25.35	22.68	48.03	60.00	-11.97	QP	
10	15.8460	12.62	22.80	35.42	50.00	-14.58	AVG	
11	21.5140	6.62	23.61	30.23	50.00	-19.77	AVG	
12	22.0780	20.95	23.68	44.63	60.00	-15.37	QP	

1. An initial pre-scan was performed on the line and neutral lines with peak detector.
2. Quasi-Peak and Average measurement were performed at the frequencies with maximized peak emission.
3. Measurement Level = Reading level + Correct Factor, Over = Limit - Measurement
4. Remark: During the test, pre-scan the 1Mbps, 2 Mbps rate, and found the 1Mbps rate which it is worse case.

### 4.2 Occupied Bandwidth

Test Requirement:	47 CFR 15.247(a)(2)
Test Limit:	Refer to 47 CFR 15.247(a)(2), Systems using digital modulation techniques may operate in the 902-928 MHz, and 2400-2483.5 MHz bands. The minimum 6 dB bandwidth shall be at least 500 kHz.
Test Method:	ANSI C63.10-2013, section 11.8 KDB 558074 D01 15.247 Meas Guidance v05r02
Procedure:	<ul style="list-style-type: none"> <li>a) Set RBW = 100 kHz.</li> <li>b) Set the VBW &gt;= [3 × RBW].</li> <li>c) Detector = peak.</li> <li>d) Trace mode = max hold.</li> <li>e) Sweep = auto couple.</li> <li>f) Allow the trace to stabilize.</li> <li>g) Measure the maximum width of the emission that is constrained by the frequencies associated with the two outermost amplitude points (upper and lower frequencies) that are attenuated by 6 dB relative to the maximum level measured in the fundamental emission.</li> </ul>

#### 4.2.1 E.U.T. Operation:

Operating Environment:					
Temperature:	23.4 °C	Humidity:	50.8 %	Atmospheric Pressure:	101 kPa
Pre test mode:	TM1				
Final test mode:	TM1				

#### 4.2.2 Test Setup Diagram:

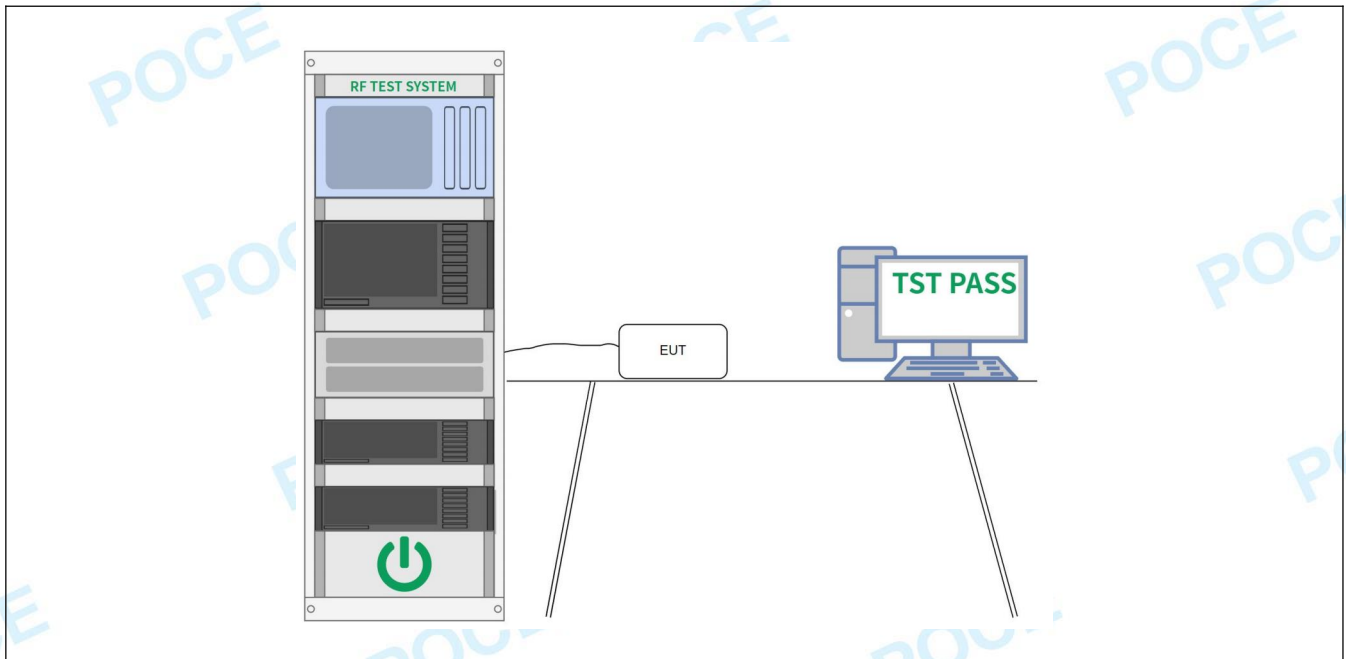

#### 4.2.3 Test Data:

Please Refer to Appendix for Details.

### 4.3 Maximum Conducted Output Power

Test Requirement:	47 CFR 15.247(b)(3)
Test Limit:	Refer to 47 CFR 15.247(b)(3), For systems using digital modulation in the 902-928 MHz, 2400-2483.5 MHz, and 5725-5850 MHz bands: 1 Watt. As an alternative to a peak power measurement, compliance with the one Watt limit can be based on a measurement of the maximum conducted output power. Maximum Conducted Output Power is defined as the total transmit power delivered to all antennas and antenna elements averaged across all symbols in the signaling alphabet when the transmitter is operating at its maximum power control level. Power must be summed across all antennas and antenna elements. The average must not include any time intervals during which the transmitter is off or is transmitting at a reduced power level. If multiple modes of operation are possible (e.g., alternative modulation methods), the maximum conducted output power is the highest total transmit power occurring in any mode.
Test Method:	ANSI C63.10-2013, section 11.9.1 KDB 558074 D01 15.247 Meas Guidance v05r02
Procedure:	ANSI C63.10-2013, section 11.9.1 Maximum peak conducted output power

#### 4.3.1 E.U.T. Operation:

Operating Environment:					
Temperature:	23.4 °C	Humidity:	50.8 %	Atmospheric Pressure:	101 kPa
Pre test mode:	TM1				
Final test mode:	TM1				

#### 4.3.2 Test Setup Diagram:

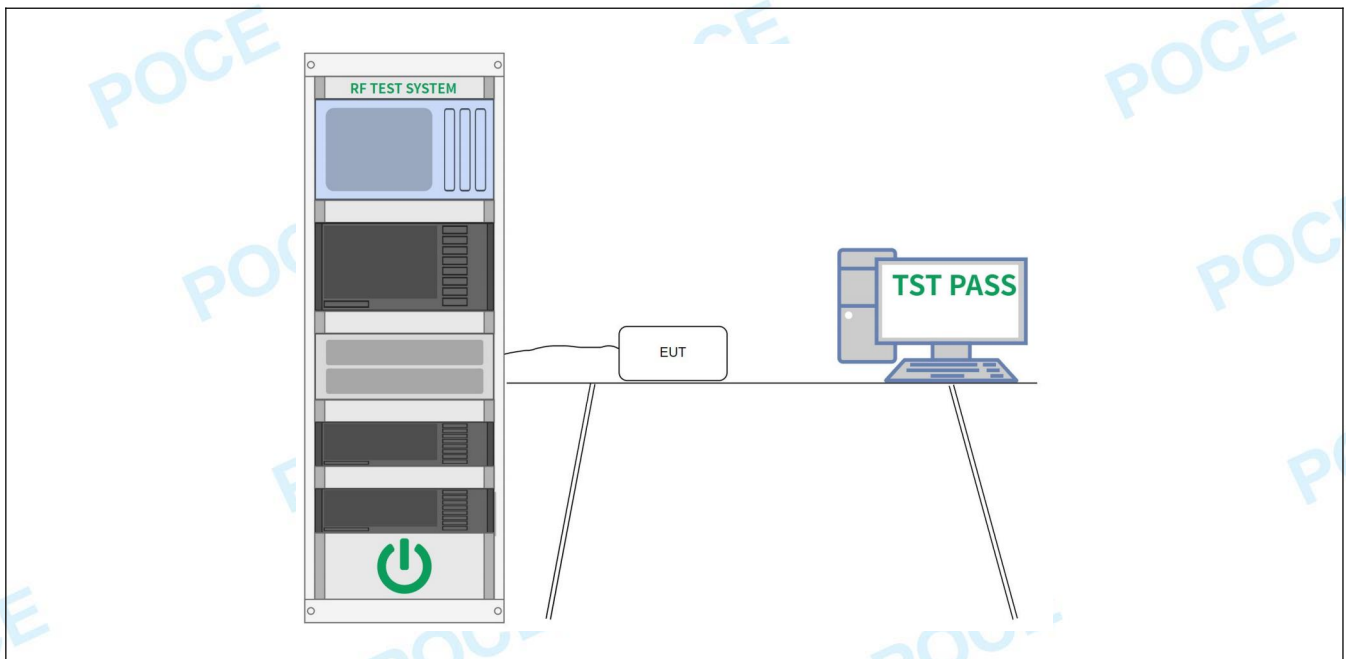

#### 4.3.3 Test Data:

Please Refer to Appendix for Details.

### 4.4 Power Spectral Density

Test Requirement:	47 CFR 15.247(e)
Test Limit:	Refer to 47 CFR 15.247(e), For digitally modulated systems, the power spectral density conducted from the intentional radiator to the antenna shall not be greater than 8 dBm in any 3 kHz band during any time interval of continuous transmission. This power spectral density shall be determined in accordance with the provisions of paragraph (b) of this section. The same method of determining the conducted output power shall be used to determine the power spectral density.
Test Method:	ANSI C63.10-2013, section 11.10 KDB 558074 D01 15.247 Meas Guidance v05r02
Procedure:	ANSI C63.10-2013, section 11.10, Maximum power spectral density level in the fundamental emission

#### 4.4.1 E.U.T. Operation:

Operating Environment:					
Temperature:	23.4 °C	Humidity:	50.8 %	Atmospheric Pressure:	101 kPa
Pre test mode:	TM1				
Final test mode:	TM1				

#### 4.4.2 Test Setup Diagram:

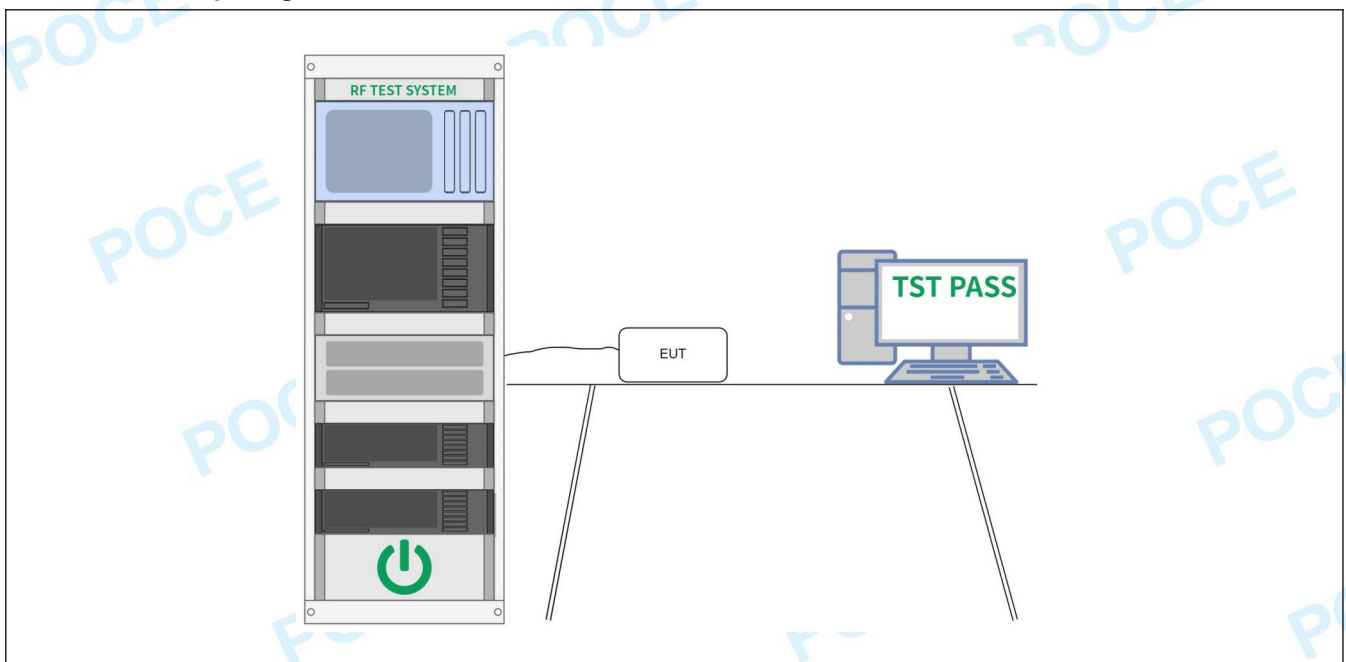

#### 4.4.3 Test Data:

Please Refer to Appendix for Details.



### 4.5 Emissions in non-restricted frequency bands

Test Requirement:	47 CFR 15.247(d)
Test Limit:	Refer to 47 CFR 15.247(d), In any 100 kHz bandwidth outside the frequency band in which the spread spectrum or digitally modulated intentional radiator is operating, the radio frequency power that is produced by the intentional radiator shall be at least 20 dB below that in the 100 kHz bandwidth within the band that contains the highest level of the desired power, based on either an RF conducted or a radiated measurement, provided the transmitter demonstrates compliance with the peak conducted power limits. If the transmitter complies with the conducted power limits based on the use of RMS averaging over a time interval, as permitted under paragraph (b)(3) of this section, the attenuation required under this paragraph shall be 30 dB instead of 20 dB. Attenuation below the general limits specified in § 15.209(a) is not required.
Test Method:	ANSI C63.10-2013 section 11.11 KDB 558074 D01 15.247 Meas Guidance v05r02
Procedure:	ANSI C63.10-2013 Section 11.11.1, Section 11.11.2, Section 11.11.3

#### 4.5.1 E.U.T. Operation:

Operating Environment:					
Temperature:	23.4 °C	Humidity:	50.8 %	Atmospheric Pressure:	101 kPa
Pre test mode:	TM1				
Final test mode:	TM1				

#### 4.5.2 Test Setup Diagram:

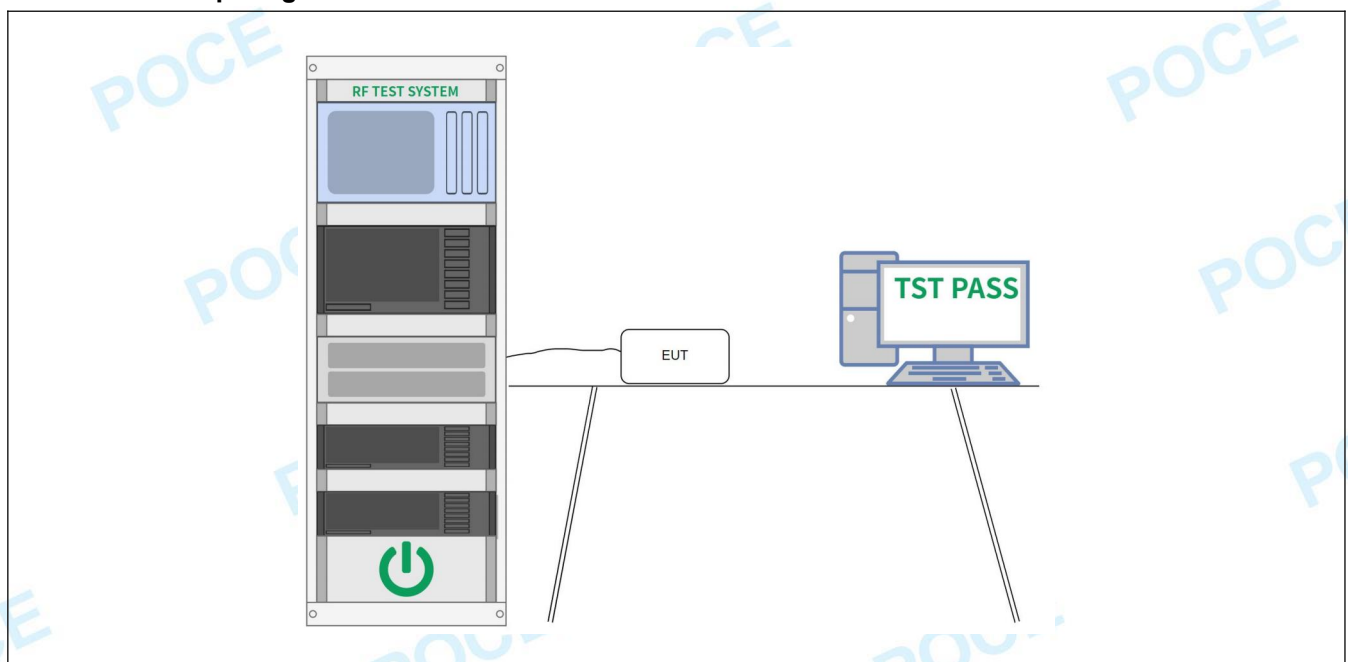

#### 4.5.3 Test Data:

Please Refer to Appendix for Details.

### 4.6 Band edge emissions (Radiated)

Test Requirement:	Refer to 47 CFR 15.247(d), In addition, radiated emissions which fall in the restricted bands, as defined in § 15.205(a), must also comply with the radiated emission limits specified in § 15.209(a)(see § 15.205(c)).		
Test Limit:	Frequency (MHz)	Field strength (microvolts/meter)	Measurement distance (meters)
	0.009-0.490	2400/F(kHz)	300
	0.490-1.705	24000/F(kHz)	30
	1.705-30.0	30	30
	30-88	100 **	3
	88-216	150 **	3
	216-960	200 **	3
	Above 960	500	3
** Except as provided in paragraph (g), fundamental emissions from intentional radiators operating under this section shall not be located in the frequency bands 54-72 MHz, 76-88 MHz, 174-216 MHz or 470-806 MHz. However, operation within these frequency bands is permitted under other sections of this part, e.g., §§ 15.231 and 15.241.			
Test Method:	ANSI C63.10-2013 section 6.10 KDB 558074 D01 15.247 Meas Guidance v05r02		
Procedure:	ANSI C63.10-2013 section 6.10.5.2		

#### 4.6.1 E.U.T. Operation:

Operating Environment:					
Temperature:	23.4 °C	Humidity:	50.8 %	Atmospheric Pressure:	101 kPa
Pre test mode:	TM1				
Final test mode:	TM1				

#### 4.6.2 Test Setup Diagram:

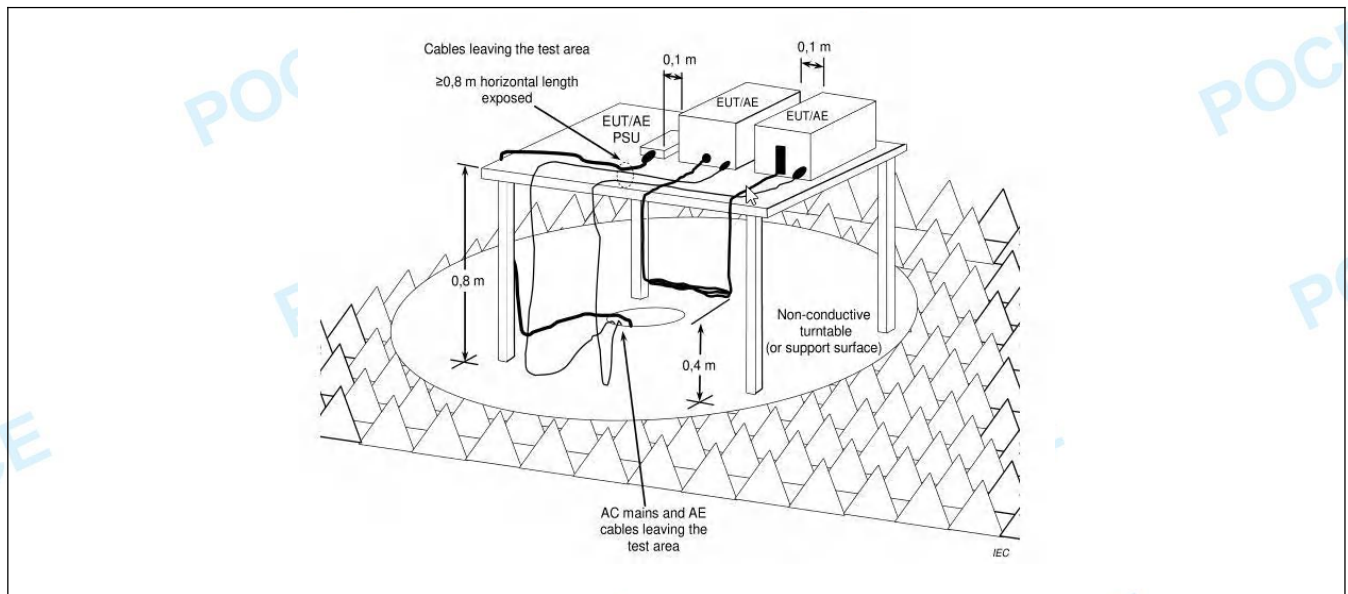

**4.6.3 Test Data:**

Remark: During the test, pre-scan the 1Mbps, 2 Mbps rate, and found the 1Mbps rate which it is worse case.

TM1 / Polarization: Horizontal / Band: 2.4G / BW: 1 / CH: L

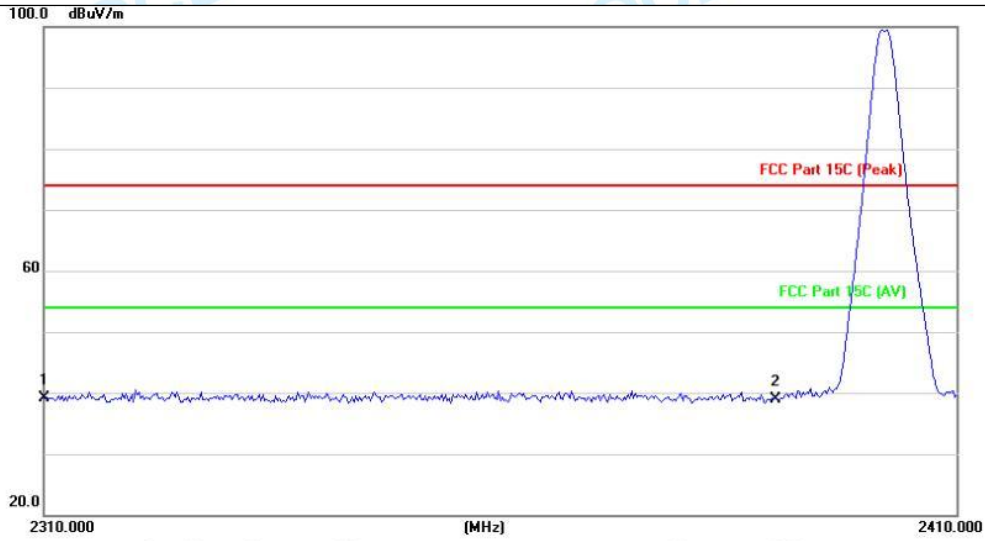

No.	Mk.	Freq.	Reading Level	Correct Factor	Measurement	Limit	Over	Antenna Height	Table Degree	
		MHz	dBuV	dB	dBuV/m	dB/m	dB	cm	degree	Comment
1	*	2310.000	42.95	-3.93	39.02	74.00	-34.98	peak		
2		2390.000	42.61	-3.72	38.89	74.00	-35.11	peak		

TM1 / Polarization: Vertical / Band: 2.4G / BW: 1 / CH: L

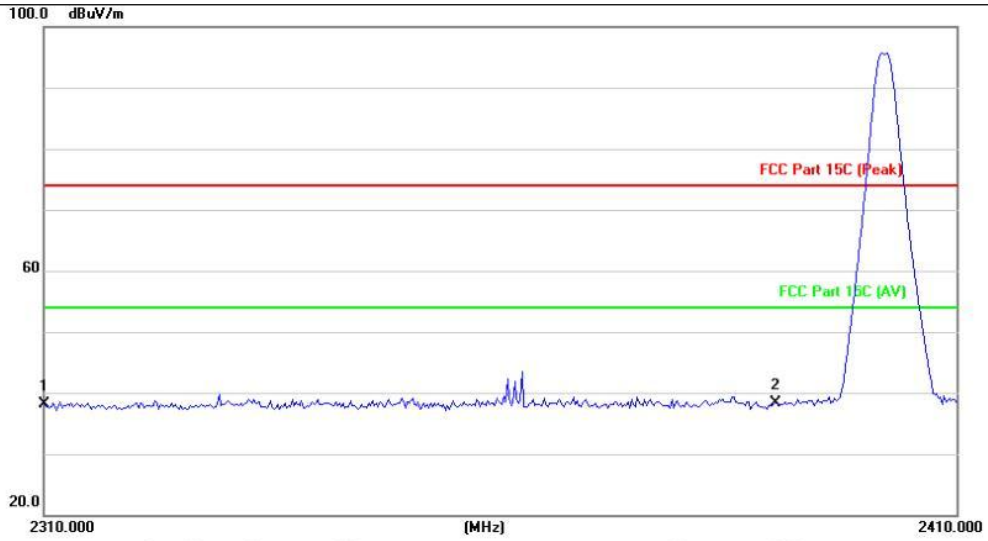

No.	Mk.	Freq. MHz	Reading Level dBuV	Correct Factor dB	Measure- ment dBuV/m	Limit dB/m	Over dB	Antenna Height cm	Table Degree	Comment
1		2310.000	43.34	-5.23	38.11	74.00	-35.89	peak		
2	*	2390.000	43.16	-4.91	38.25	74.00	-35.75	peak		



TM3 / Polarization: Horizontal / Band: 2.4G / BW: 1 / CH: H

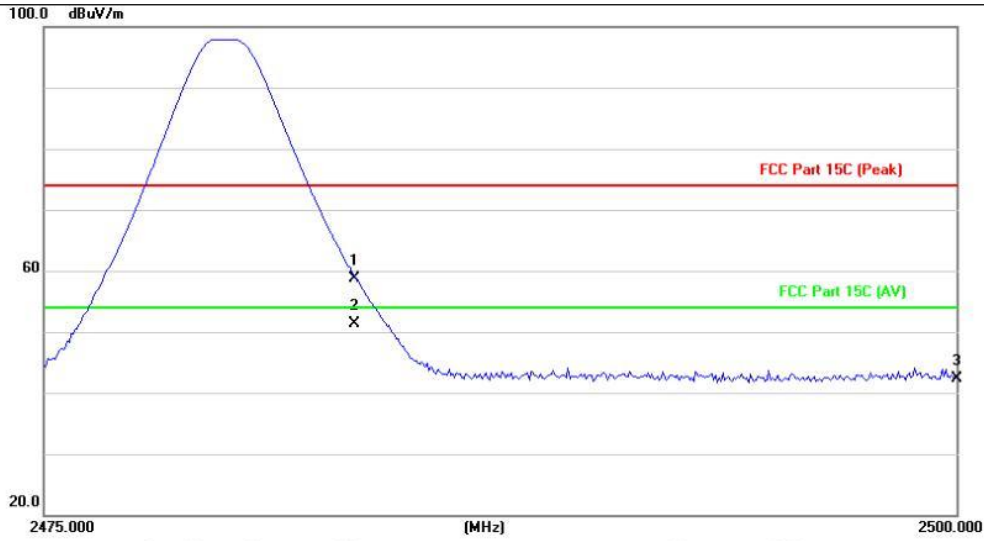

No. Mk.	Freq. MHz	Reading Level dBuV	Correct Factor dB	Measurement dBuV/m	Limit dB/m	Over dB	Detector	Antenna Height cm	Table Degree	Comment
1	2483.500	62.26	-3.47	58.79	74.00	-15.21	peak	100	147	
2	* 2483.500	54.81	-3.47	51.34	54.00	-2.66	AVG	100	147	
3	2500.000	45.78	-3.43	42.35	74.00	-31.65	peak	100	147	

TM3 / Polarization: Vertical / Band: 2.4G / BW: 1 / CH: H

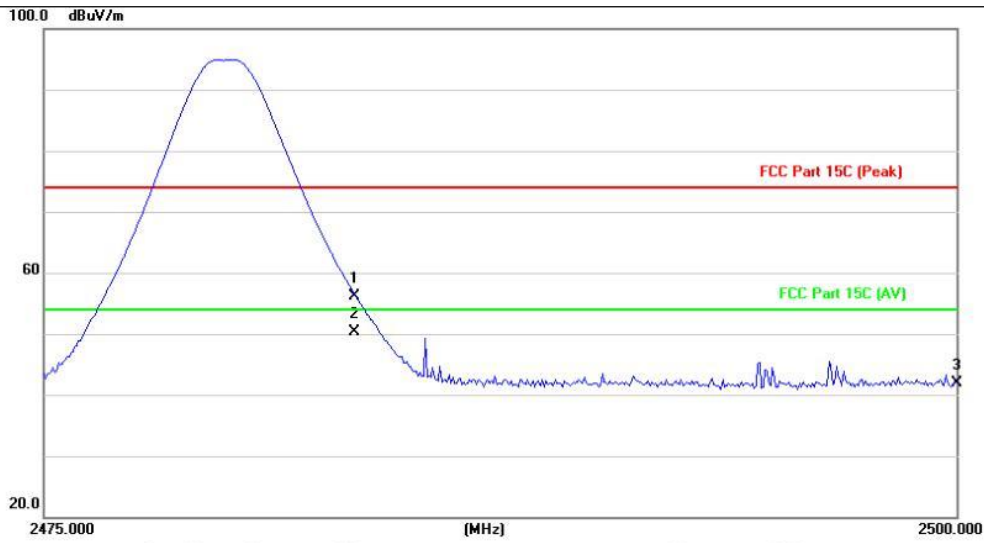

No.	Mk.	Freq. MHz	Reading Level dBuV	Correct Factor dB	Measure- ment dBuV/m	Limit dB/m	Over dB	Antenna Height cm	Table Degree	Comment
1		2483.500	60.64	-4.54	56.10	74.00	-17.90	peak	100	240
2	*	2483.500	54.78	-4.54	50.24	54.00	-3.76	AVG	100	240
3		2500.000	46.30	-4.48	41.82	74.00	-32.18	peak	100	240

Remark:

1. Quasi-Peak and Average measurement were performed at the frequencies with maximized peak emission.
2. Measurement Level = Reading level + Correct Factor, Over=Limit- Measurement  
Correction Factor= Antenna Factor + Cable loss – Pre-amplifier

### 4.7 Emissions in restricted frequency bands (below 1GHz)

Test Requirement:	Refer to 47 CFR 15.247(d), In addition, radiated emissions which fall in the restricted bands, as defined in § 15.205(a), must also comply with the radiated emission limits specified in § 15.209(a)(see § 15.205(c)).		
Test Limit:	Frequency (MHz)	Field strength (microvolts/meter)	Measurement distance (meters)
	0.009-0.490	2400/F(kHz)	300
	0.490-1.705	24000/F(kHz)	30
	1.705-30.0	30	30
	30-88	100 **	3
	88-216	150 **	3
	216-960	200 **	3
	Above 960	500	3
	** Except as provided in paragraph (g), fundamental emissions from intentional radiators operating under this section shall not be located in the frequency bands 54-72 MHz, 76-88 MHz, 174-216 MHz or 470-806 MHz. However, operation within these frequency bands is permitted under other sections of this part, e.g., §§ 15.231 and 15.241.		
Test Method:	ANSI C63.10-2013 section 6.6.4 KDB 558074 D01 15.247 Meas Guidance v05r02		
Procedure:	<p>a. For below 1GHz, the EUT was placed on the top of a rotating table 0.8 meters above the ground at a 3 or 10 meter semi-anechoic chamber. The table was rotated 360 degrees to determine the position of the highest radiation.</p> <p>b. For above 1GHz, the EUT was placed on the top of a rotating table 1.5 meters above the ground at a 3 meter fully-anechoic chamber. The table was rotated 360 degrees to determine the position of the highest radiation.</p> <p>c. The EUT was set 3 or 10 meters away from the interference-receiving antenna, which was mounted on the top of a variable-height antenna tower.</p> <p>d. The antenna height is varied from one meter to four meters above the ground to determine the maximum value of the field strength. Both horizontal and vertical polarizations of the antenna are set to make the measurement.</p> <p>e. For each suspected emission, the EUT was arranged to its worst case and then the antenna was tuned to heights from 1 meter to 4 meters (for the test frequency of below 30MHz, the antenna was tuned to heights 1 meter) and the rotatable table was turned from 0 degrees to 360 degrees to find the maximum reading.</p> <p>f. The test-receiver system was set to Peak Detect Function and Specified Bandwidth with Maximum Hold Mode.</p> <p>g. If the emission level of the EUT in peak mode was 10dB lower than the limit specified, then testing could be stopped and the peak values of the EUT would be reported. Otherwise the emissions that did not have 10dB margin would be re-tested one by one using peak, quasi-peak or average method as specified and then reported in a data sheet.</p> <p>h. Test the EUT in the lowest channel, the middle channel, the Highest channel.</p> <p>i. The radiation measurements are performed in X, Y, Z axis positioning for Transmitting mode, and found the X axis positioning which it is the worst case.</p> <p>j. Repeat above procedures until all frequencies measured was complete.</p> <p>Remark:</p> <p>1) For emission below 1GHz, through pre-scan found the worst case is the lowest channel. Only the worst case is recorded in the report.</p> <p>2) The field strength is calculated by adding the Antenna Factor, Cable Factor &amp; Preamplifier. The basic equation with a sample calculation is as follows: Final Test Level =Receiver Reading + Antenna Factor + Cable Factor + Preamplifier Factor</p> <p>3) Scan from 9kHz to 25GHz, the disturbance above 12.75GHz and below 30MHz was very low. The points marked on above plots are the highest emissions could be found when testing, so only above points had been displayed. The amplitude of spurious emissions from the radiator which are attenuated more than 20dB below</p>		



the limit need not be reported. Fundamental frequency is blocked by filter, and only spurious emission is shown.

#### 4.7.1 E.U.T. Operation:

Operating Environment:					
Temperature:	23.4 °C	Humidity:	50.8 %	Atmospheric Pressure:	101 kPa
Pre test mode:	TM1				
Final test mode:	TM1				



**4.7.2 Test Data:**

TM1 / Polarization: Horizontal / Band: 2.4G / BW: 1 / CH: L



No.	Mk.	Freq. MHz	Reading Level dBuV	Correct Factor dB	Measure- ment dBuV/m	Limit dB/m	Over dB	Antenna Height cm	Table Degree	Comment
1		193.0945	39.06	-6.87	32.19	43.50	-11.31	QP 100	354	
2	*	300.3672	46.04	-3.97	42.07	46.00	-3.93	QP 100	289	
3		400.4318	40.37	-1.80	38.57	46.00	-7.43	QP 100	135	
4		501.1789	37.59	0.58	38.17	46.00	-7.83	QP 100	256	
5		701.7609	29.47	3.56	33.03	46.00	-12.97	QP 100	54	
6		916.0687	24.65	7.58	32.23	46.00	-13.77	QP 100	277	

TM1 / Polarization: Vertical / Band: 2.4G / BW: 1 / CH: L

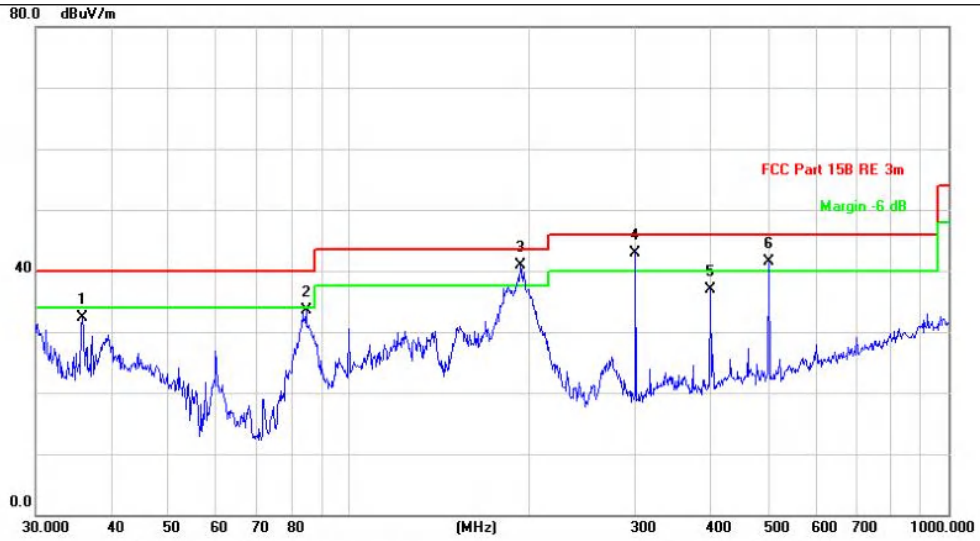

No. Mk.	Freq. MHz	Reading Level dBuV	Correct Factor dB	Measurement dBuV/m	Limit dB/m	Over dB	Antenna Height cm	Table Degree	Comment
1	35.8746	33.71	-1.47	32.24	40.00	-7.76	QP 100	147	
2	84.7018	45.12	-11.56	33.56	40.00	-6.44	QP 100	25	
3	* 193.0945	47.77	-6.87	40.90	43.50	-2.60	QP 100	341	
4	! 300.3672	46.88	-3.97	42.91	46.00	-3.09	QP 100	125	
5	400.4318	38.74	-1.80	36.94	46.00	-9.06	QP 100	246	
6	! 501.1789	40.93	0.58	41.51	46.00	-4.49	QP 100	89	

Remark: Over= Measurement Level - Limit  
 Measurement Level=Test receiver reading + correction factor  
 Correction Factor= Antenna Factor + Cable loss – Pre-amplifier

### 4.8 Emissions in restricted frequency bands (above 1GHz)

Test Requirement:	In addition, radiated emissions which fall in the restricted bands, as defined in § 15.205(a), must also comply with the radiated emission limits specified in § 15.209(a)(see § 15.205(c)).`		
Test Limit:	Frequency (MHz)	Field strength (microvolts/meter)	Measurement distance (meters)
	0.009-0.490	2400/F(kHz)	300
	0.490-1.705	24000/F(kHz)	30
	1.705-30.0	30	30
	30-88	100 **	3
	88-216	150 **	3
	216-960	200 **	3
	Above 960	500	3
	** Except as provided in paragraph (g), fundamental emissions from intentional radiators operating under this section shall not be located in the frequency bands 54-72 MHz, 76-88 MHz, 174-216 MHz or 470-806 MHz. However, operation within these frequency bands is permitted under other sections of this part, e.g., §§ 15.231 and 15.241.		
Test Method:	ANSI C63.10-2013 section 6.6.4 KDB 558074 D01 15.247 Meas Guidance v05r02		
Procedure:	<p>a. For below 1GHz, the EUT was placed on the top of a rotating table 0.8 meters above the ground at a 3 or 10 meter semi-anechoic chamber. The table was rotated 360 degrees to determine the position of the highest radiation.</p> <p>b. For above 1GHz, the EUT was placed on the top of a rotating table 1.5 meters above the ground at a 3 meter fully-anechoic chamber. The table was rotated 360 degrees to determine the position of the highest radiation.</p> <p>c. The EUT was set 3 or 10 meters away from the interference-receiving antenna, which was mounted on the top of a variable-height antenna tower.</p> <p>d. The antenna height is varied from one meter to four meters above the ground to determine the maximum value of the field strength. Both horizontal and vertical polarizations of the antenna are set to make the measurement.</p> <p>e. For each suspected emission, the EUT was arranged to its worst case and then the antenna was tuned to heights from 1 meter to 4 meters (for the test frequency of below 30MHz, the antenna was tuned to heights 1 meter) and the rotatable table was turned from 0 degrees to 360 degrees to find the maximum reading.</p> <p>f. The test-receiver system was set to Peak Detect Function and Specified Bandwidth with Maximum Hold Mode.</p> <p>g. If the emission level of the EUT in peak mode was 10dB lower than the limit specified, then testing could be stopped and the peak values of the EUT would be reported. Otherwise the emissions that did not have 10dB margin would be re-tested one by one using peak, quasi-peak or average method as specified and then reported in a data sheet.</p> <p>h. Test the EUT in the lowest channel, the middle channel, the Highest channel.</p> <p>i. The radiation measurements are performed in X, Y, Z axis positioning for Transmitting mode, and found the X axis positioning which it is the worst case.</p> <p>j. Repeat above procedures until all frequencies measured was complete.</p> <p>Remark:</p> <p>1) For emission below 1GHz, through pre-scan found the worst case is the lowest channel. Only the worst case is recorded in the report.</p> <p>2) The field strength is calculated by adding the Antenna Factor, Cable Factor &amp; Pre-amplifier. The basic equation with a sample calculation is as follows: Final Test Level =Receiver Reading + Antenna Factor + Cable Factor +C Pre-amplifier Factor</p> <p>3) Scan from 9kHz to 25GHz, the disturbance above 12.75GHz and below 30MHz was very low. The points marked on above plots are the highest emissions could be found when testing, so only above points had been displayed. The amplitude of spurious emissions from the radiator which are attenuated more than 20dB below</p>		

the limit need not be reported. Fundamental frequency is blocked by filter, and only spurious emission is shown.

**4.8.1 E.U.T. Operation:**

Operating Environment:					
Temperature:	23.4 °C	Humidity:	50.8 %	Atmospheric Pressure:	101 kPa
Pre test mode:	TM1				
Final test mode:	TM1				

**4.8.2 Test Setup Diagram:**

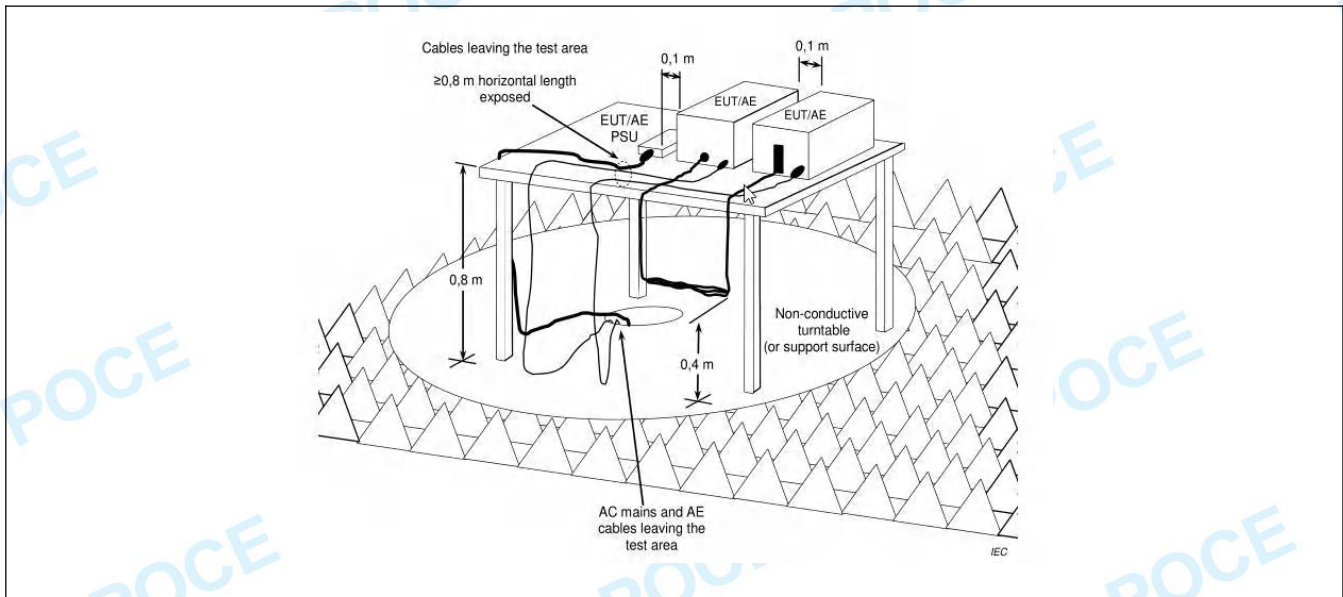



**4.8.3 Test Data:**

Remark: During the test, pre-scan the 1Mbps, 2 Mbps rate, and found the 1Mbps rate which it is worse case.

TM1 / Polarization: Horizontal / Band: 2.4G / BW: 1 / CH: L

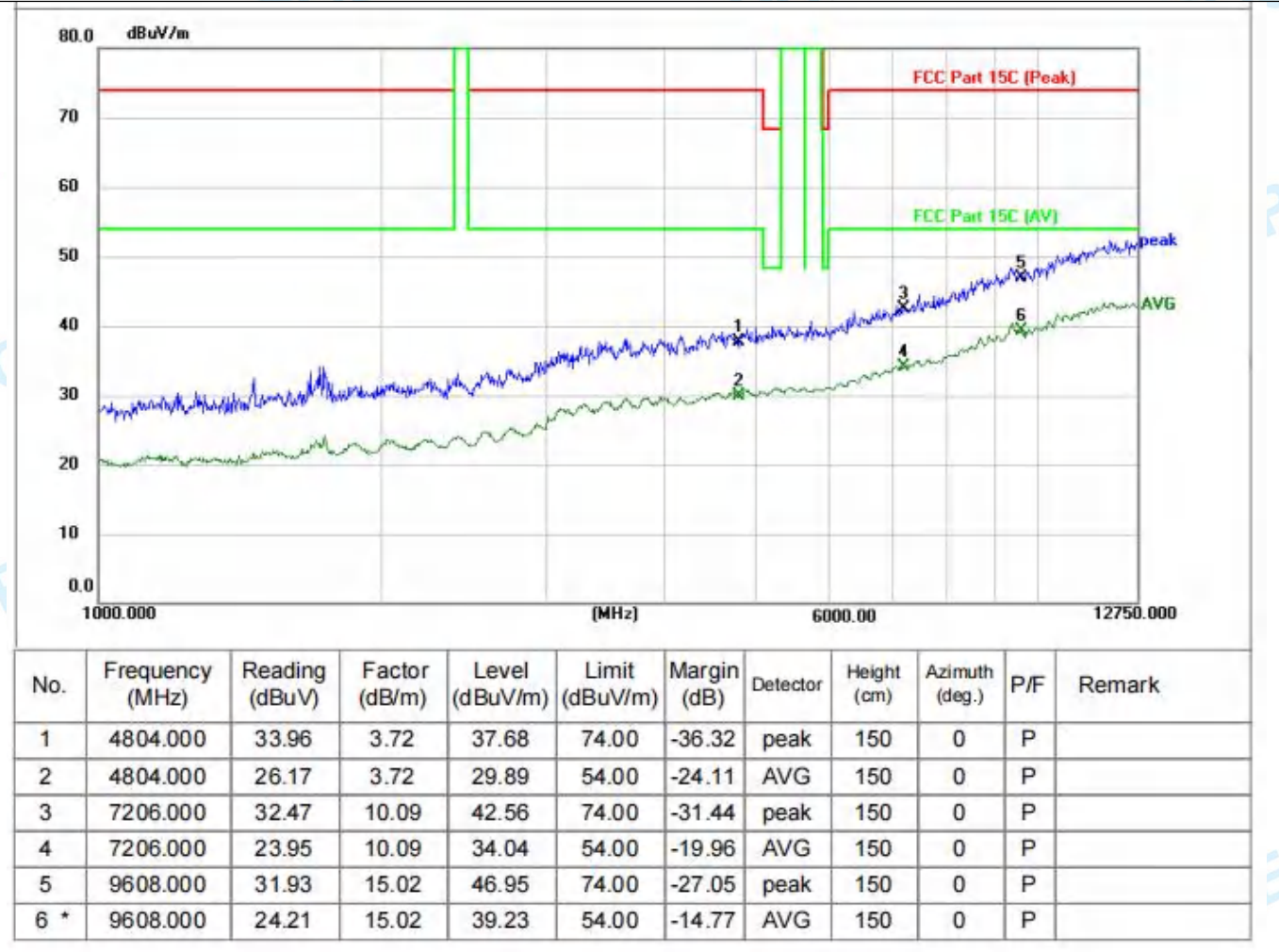

TM1 / Polarization: Vertical / Band: 2.4G / BW: 1 / CH: L

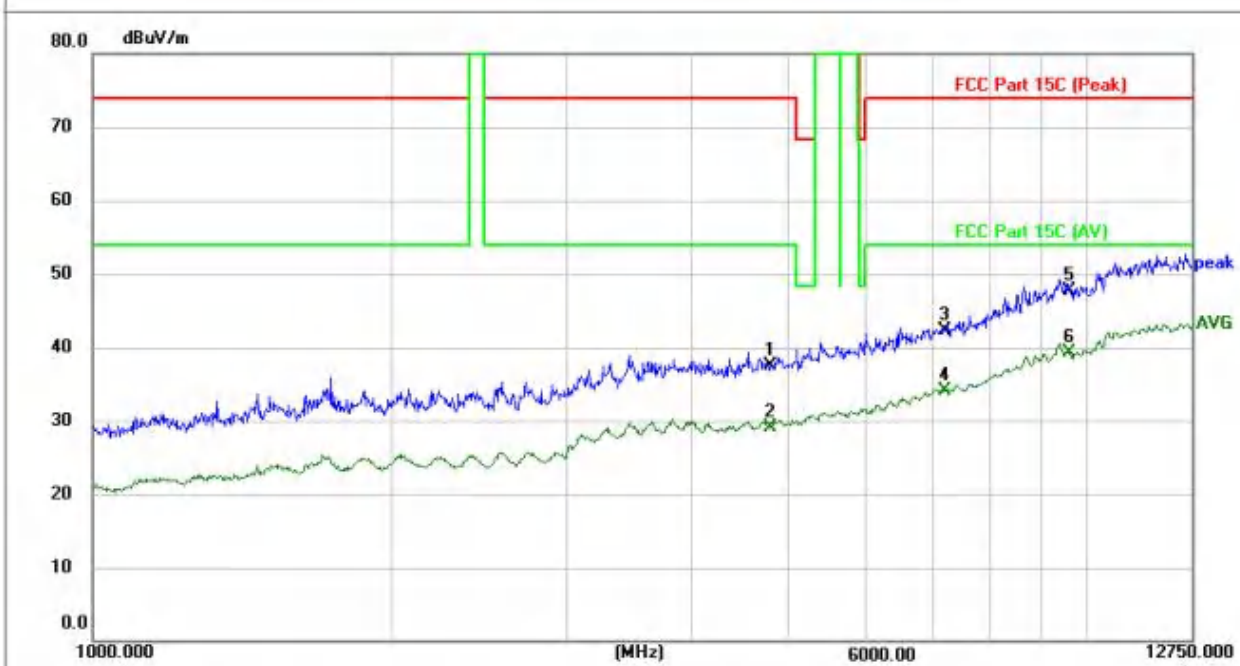

No.	Frequency (MHz)	Reading (dBuV)	Factor (dB/m)	Level (dBuV/m)	Limit (dBuV/m)	Margin (dB)	Detector	Height (cm)	Azimuth (deg.)	P/F	Remark
1	4804.000	34.45	3.10	37.55	74.00	-36.45	peak	150	0	P	
2	4804.000	26.06	3.10	29.16	54.00	-24.84	AVG	150	0	P	
3	7206.000	32.18	10.13	42.31	74.00	-31.69	peak	150	0	P	
4	7206.000	23.92	10.13	34.05	54.00	-19.95	AVG	150	0	P	
5	9608.000	32.65	15.09	47.74	74.00	-26.26	peak	150	0	P	
6 *	9608.000	24.24	15.09	39.33	54.00	-14.67	AVG	150	0	P	

TM2 / Polarization: Horizontal / Band: 2.4G / BW: 1 / CH: M

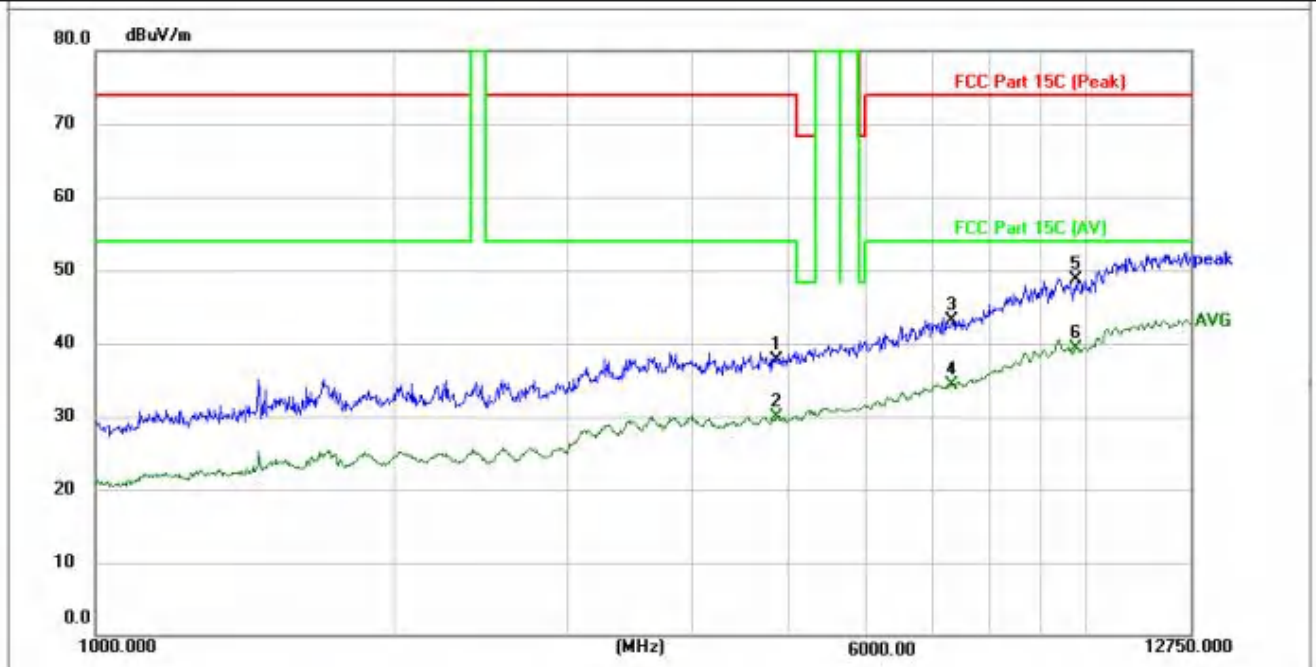

No.	Frequency (MHz)	Reading (dBuV)	Factor (dB/m)	Level (dBuV/m)	Limit (dBuV/m)	Margin (dB)	Detector	Height (cm)	Azimuth (deg.)	P/F	Remark
1	4880.000	34.35	3.35	37.70	74.00	-36.30	peak	150	0	P	
2	4880.000	26.58	3.35	29.93	54.00	-24.07	AVG	150	0	P	
3	7320.000	32.72	10.31	43.03	74.00	-30.97	peak	150	0	P	
4	7320.000	24.00	10.31	34.31	54.00	-19.69	AVG	150	0	P	
5	9760.000	33.68	15.09	48.77	74.00	-25.23	peak	150	0	P	
6 *	9760.000	24.18	15.09	39.27	54.00	-14.73	AVG	150	0	P	



TM2 / Polarization: Vertical / Band: 2.4G / BW: 1 / CH: M

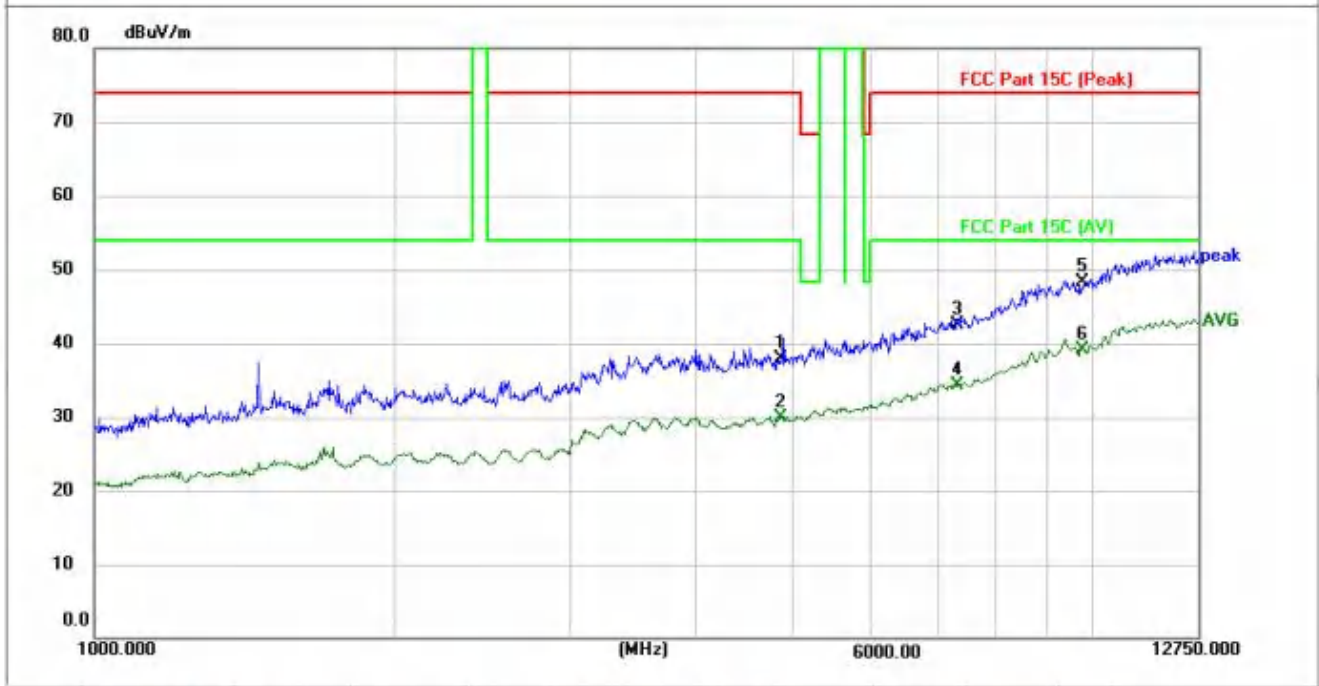

No.	Frequency (MHz)	Reading (dBuV)	Factor (dB/m)	Level (dBuV/m)	Limit (dBuV/m)	Margin (dB)	Detector	Height (cm)	Azimuth (deg.)	P/F	Remark
1	4880.000	33.99	3.97	37.96	74.00	-36.04	peak	150	0	P	
2	4880.000	26.01	3.97	29.98	54.00	-24.02	AVG	150	0	P	
3	7320.000	32.05	10.36	42.41	74.00	-31.59	peak	150	0	P	
4	7320.000	23.88	10.36	34.24	54.00	-19.76	AVG	150	0	P	
5	9760.000	33.18	15.12	48.30	74.00	-25.70	peak	150	0	P	
6 *	9760.000	24.07	15.12	39.19	54.00	-14.81	AVG	150	0	P	



TM3 / Polarization: Horizontal / Band: 2.4G / BW: 1 / CH: H

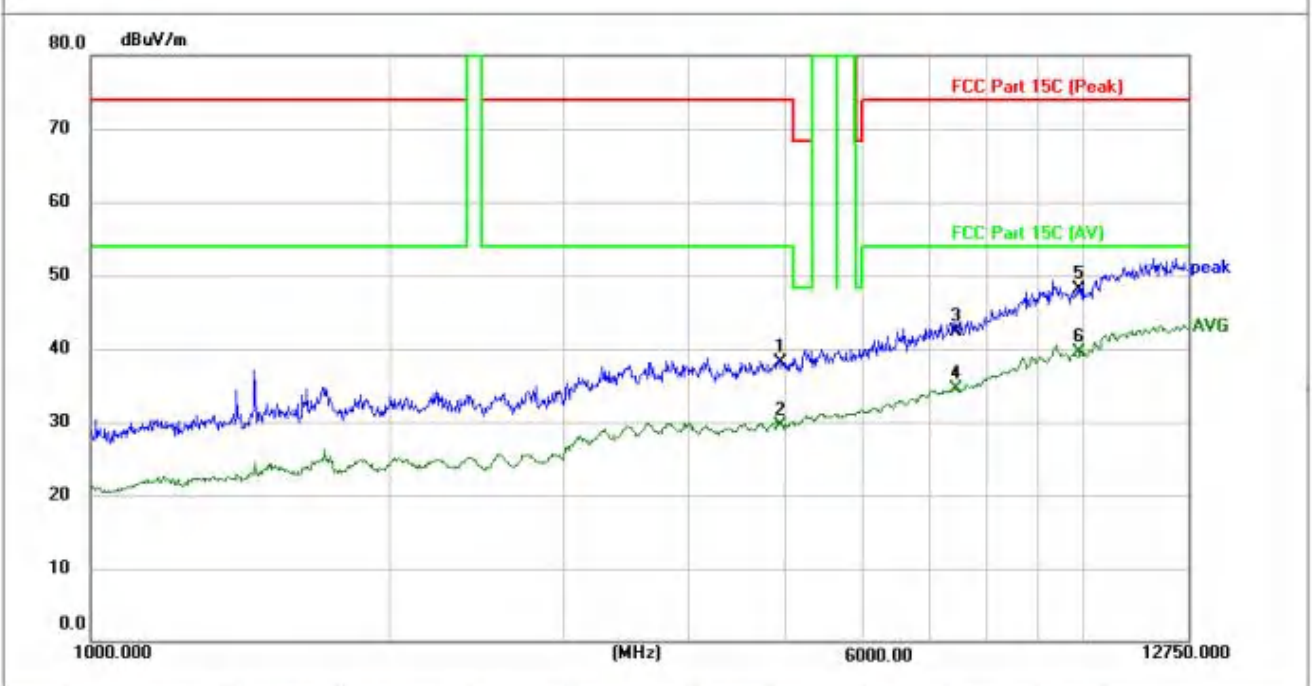

No.	Frequency (MHz)	Reading (dBuV)	Factor (dB/m)	Level (dBuV/m)	Limit (dBuV/m)	Margin (dB)	Detector	Height (cm)	Azimuth (deg.)	P/F	Remark
1	4960.000	33.84	4.23	38.07	74.00	-35.93	peak	150	0	P	
2	4960.000	25.27	4.23	29.50	54.00	-24.50	AVG	150	0	P	
3	7440.000	31.61	10.64	42.25	74.00	-31.75	peak	150	0	P	
4	7440.000	23.90	10.64	34.54	54.00	-19.46	AVG	150	0	P	
5	9920.000	32.81	15.23	48.04	74.00	-25.96	peak	150	0	P	
6 *	9920.000	24.30	15.23	39.53	54.00	-14.47	AVG	150	0	P	

TM3 / Polarization: Vertical / Band: 2.4G / BW: 1 / CH: H

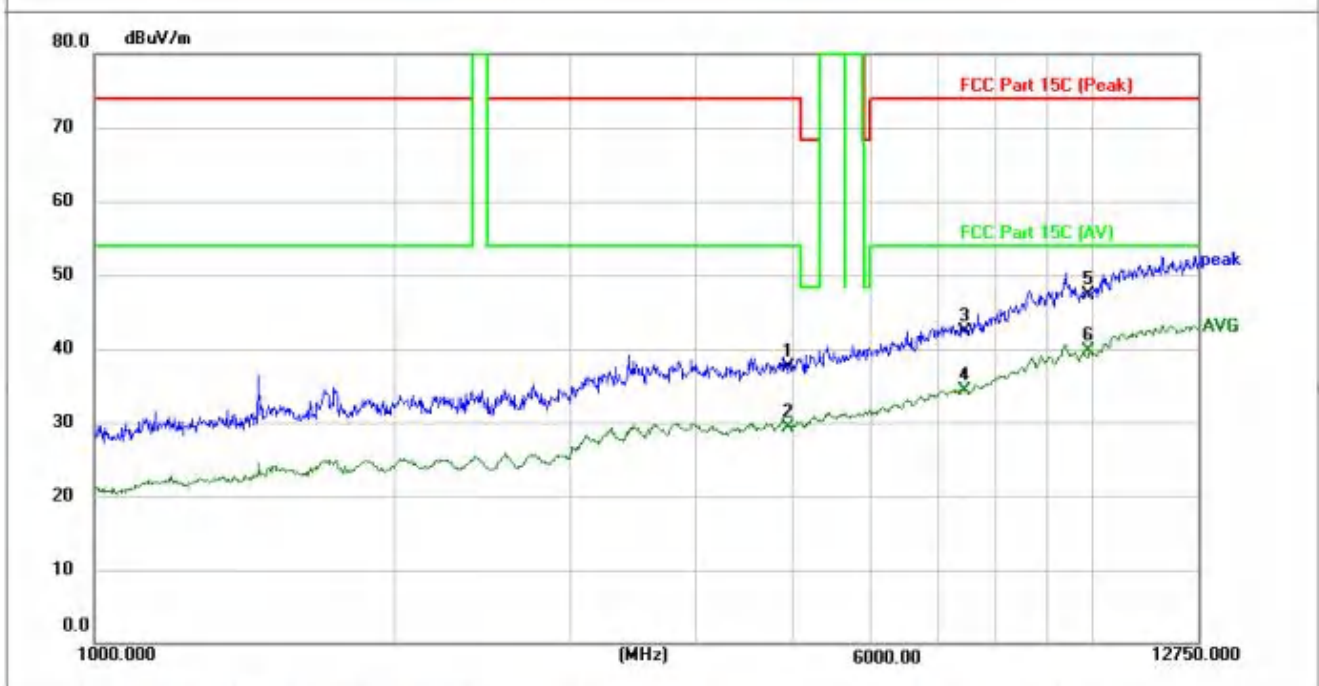

No.	Frequency (MHz)	Reading (dBuV)	Factor (dB/m)	Level (dBuV/m)	Limit (dBuV/m)	Margin (dB)	Detector	Height (cm)	Azimuth (deg.)	P/F	Remark
1	4960.000	33.84	3.63	37.47	74.00	-36.53	peak	150	0	P	
2	4960.000	25.75	3.63	29.38	54.00	-24.62	AVG	150	0	P	
3	7440.000	31.77	10.49	42.26	74.00	-31.74	peak	150	0	P	
4	7440.000	23.89	10.49	34.38	54.00	-19.62	AVG	150	0	P	
5	9920.000	32.27	15.08	47.35	74.00	-26.65	peak	150	0	P	
6 *	9920.000	24.55	15.08	39.63	54.00	-14.37	AVG	150	0	P	

Remark: Over= Measurement Level - Limit  
 Measurement Level=Test receiver reading + correction factor  
 Correction Factor= Antenna Factor + Cable loss – Pre-amplifier



## 5 TEST SETUP PHOTOS

Please refer to Setup Photo file

## 6 PHOTOS OF THE EUT

Please refer to external photos file and internal photos file



# Appendix



### 1. -6dB Bandwidth

Condition	Antenna	Rate	Frequency (MHz)	-6dB BW(kHz)	limit(kHz)	Result
NVNT	ANT1	1Mbps	2402.00	680.09	500	Pass
NVNT	ANT1	1Mbps	2440.00	696.58	500	Pass
NVNT	ANT1	1Mbps	2480	677.41	500	Pass
NVNT	ANT1	2Mbps	2402.00	1371.28	500	Pass
NVNT	ANT1	2Mbps	2440.00	1408.65	500	Pass
NVNT	ANT1	2Mbps	2480	1378.32	500	Pass

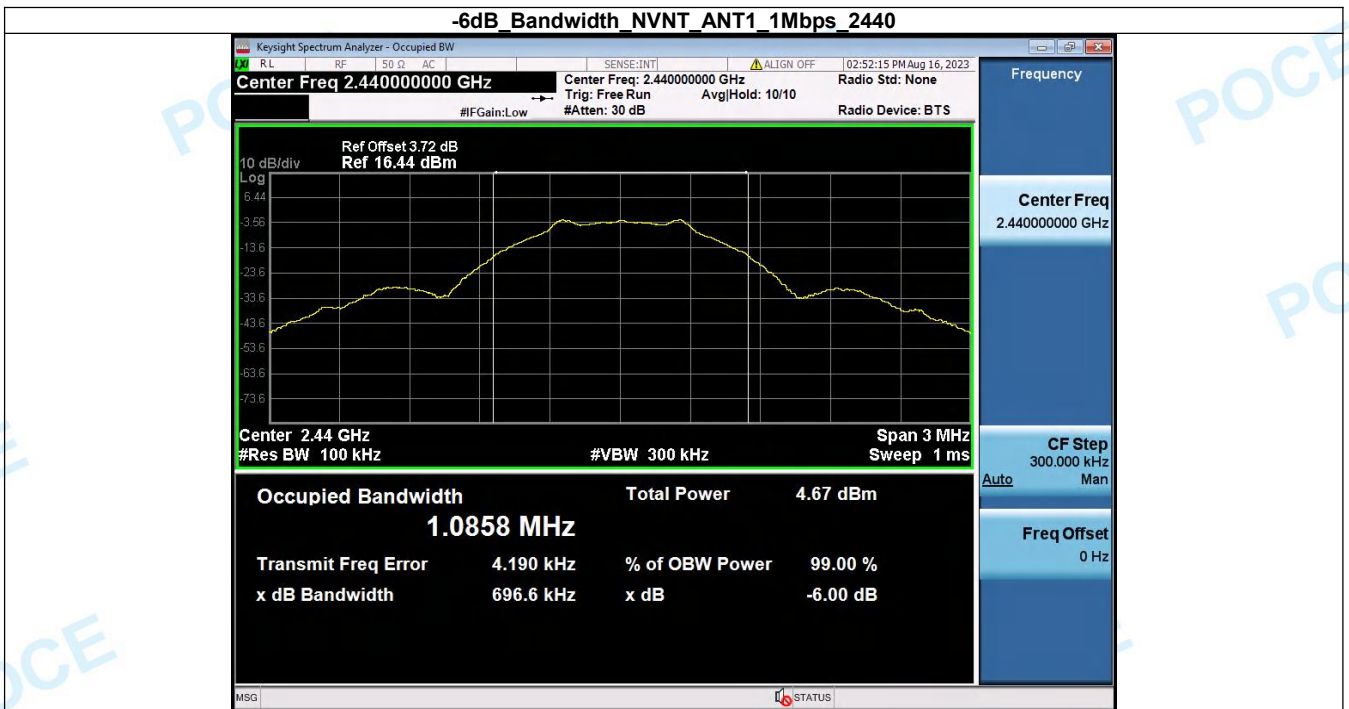
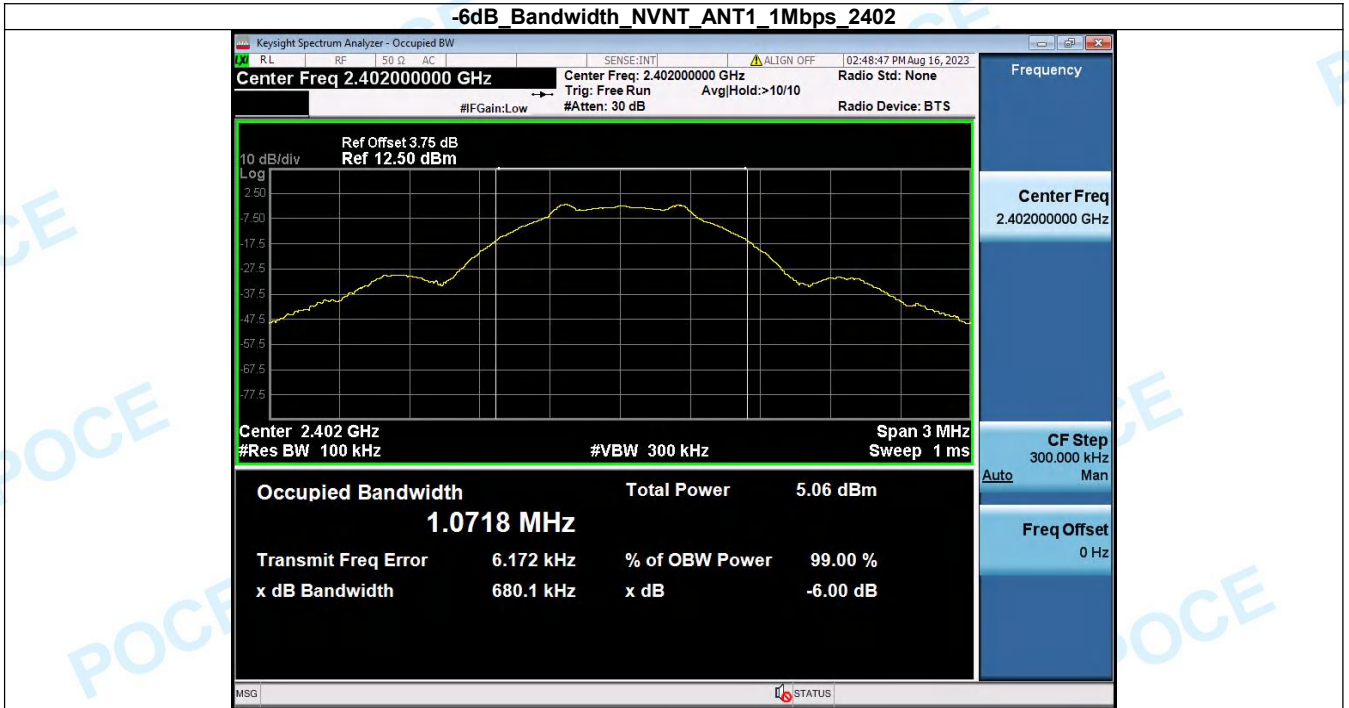

**-6dB Bandwidth\_NVNT\_ANT1\_1Mbps\_2480**

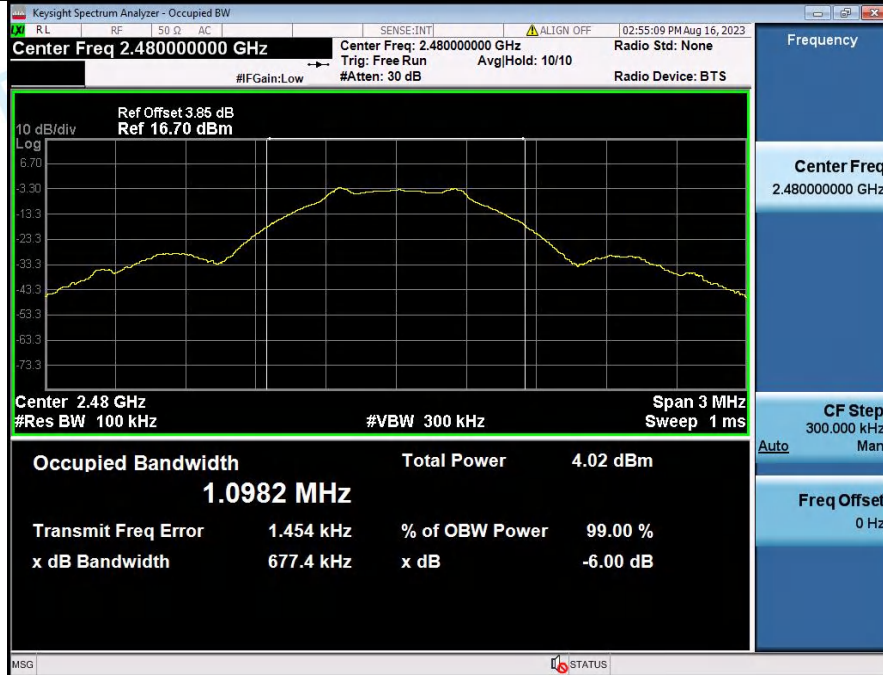

**-6dB Bandwidth\_NVNT\_ANT1\_2Mbps\_2402**



**-6dB Bandwidth\_NVNT\_ANT1\_2Mbps\_2440**



**-6dB Bandwidth\_NVNT\_ANT1\_2Mbps\_2480**

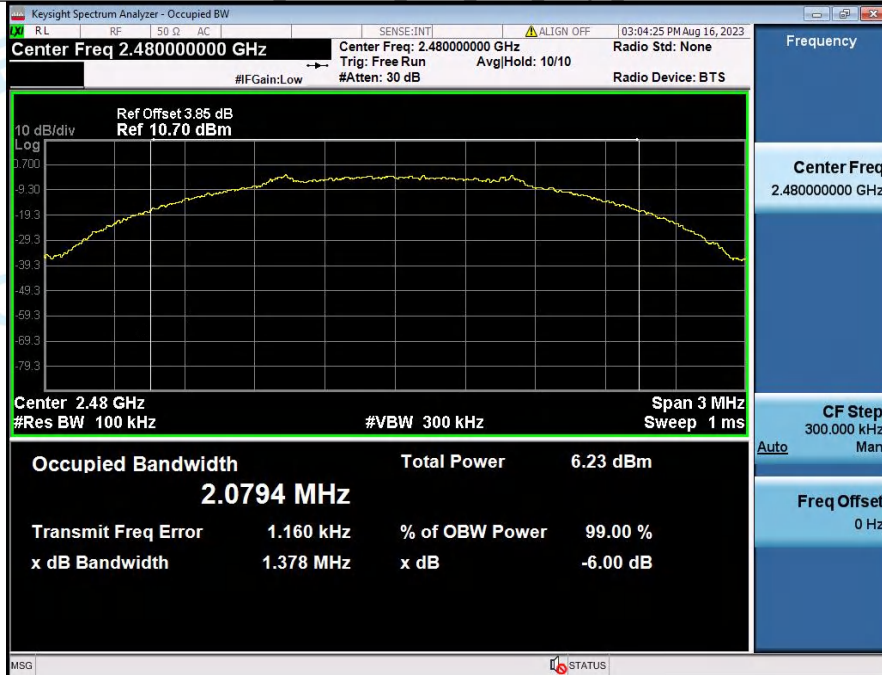



## 2. Bandedge

Condition	Antenna	Rate	TX_Frequency (MHz)	Max. Mark Frequency (MHz)	Spurious level(dBm)	limit(dBm)	Result
NVNT	ANT1	1Mbps	2402.00	2399.965	-54.436	-22.174	Pass
NVNT	ANT1	1Mbps	2480	2486.675	-62.987	-22.970	Pass
NVNT	ANT1	2Mbps	2402.00	2399.965	-34.590	-23.554	Pass
NVNT	ANT1	2Mbps	2480	2483.575	-63.600	-24.438	Pass

1 Reference Level\_NVNT\_ANT1\_1Mbps\_2402



2 Bandedge\_NVNT\_ANT1\_1Mbps\_2402

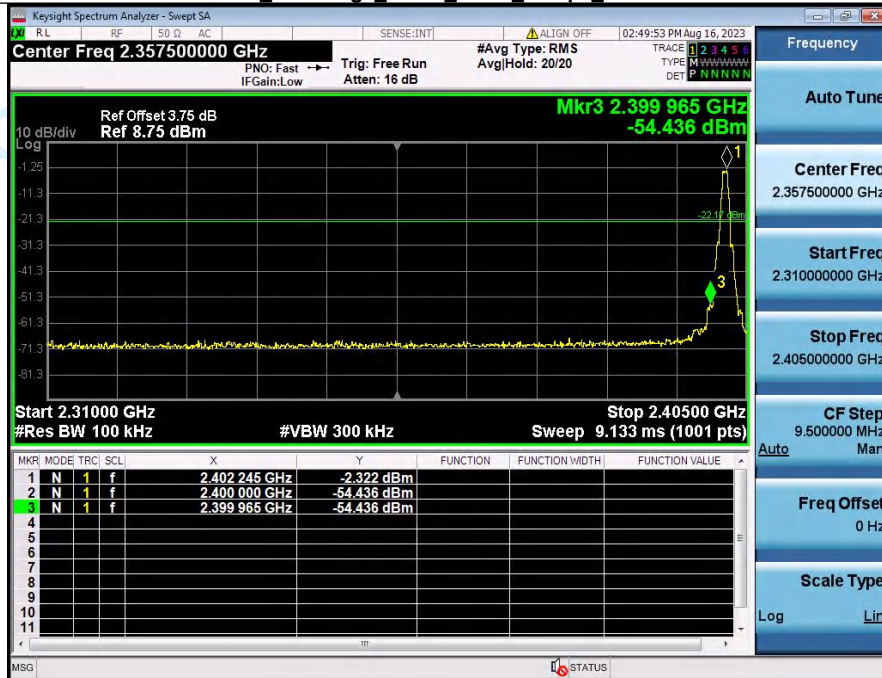



1 Reference Level NVNT ANT1 1Mbps 2480



2 Bandedge NVNT ANT1 1Mbps 2480

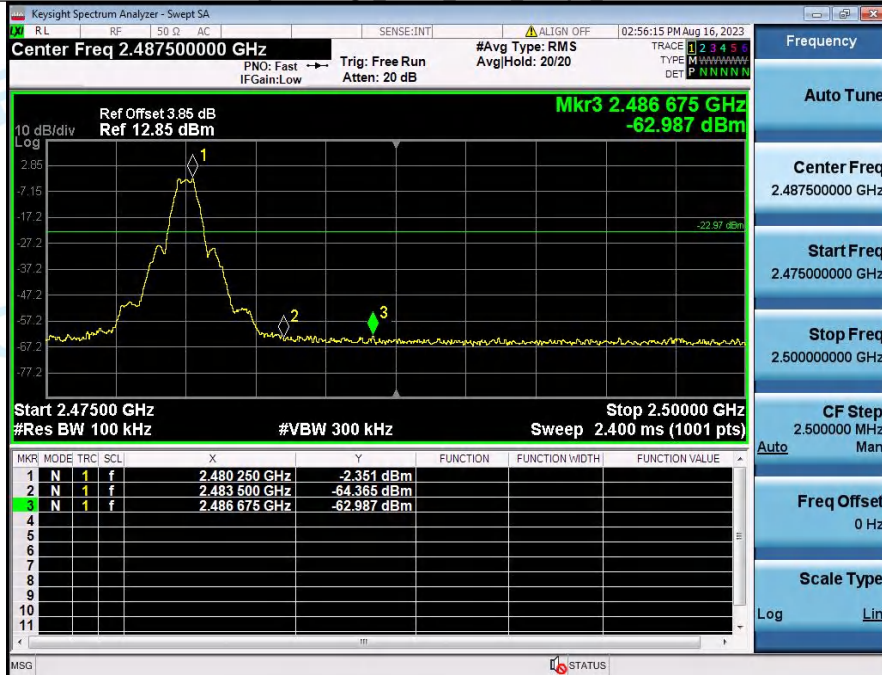

1 Reference Level NVNT ANT1 2Mbps 2402



2 Bandedge NVNT ANT1 2Mbps 2402

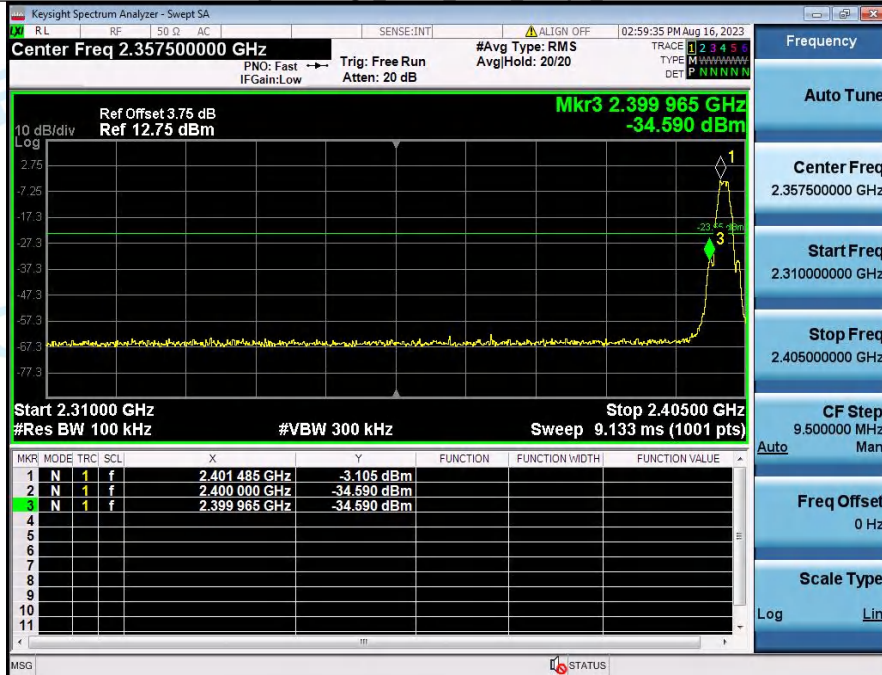

1 Reference Level NVNT ANT1 2Mbps 2480



2 Bandedge NVNT ANT1 2Mbps 2480

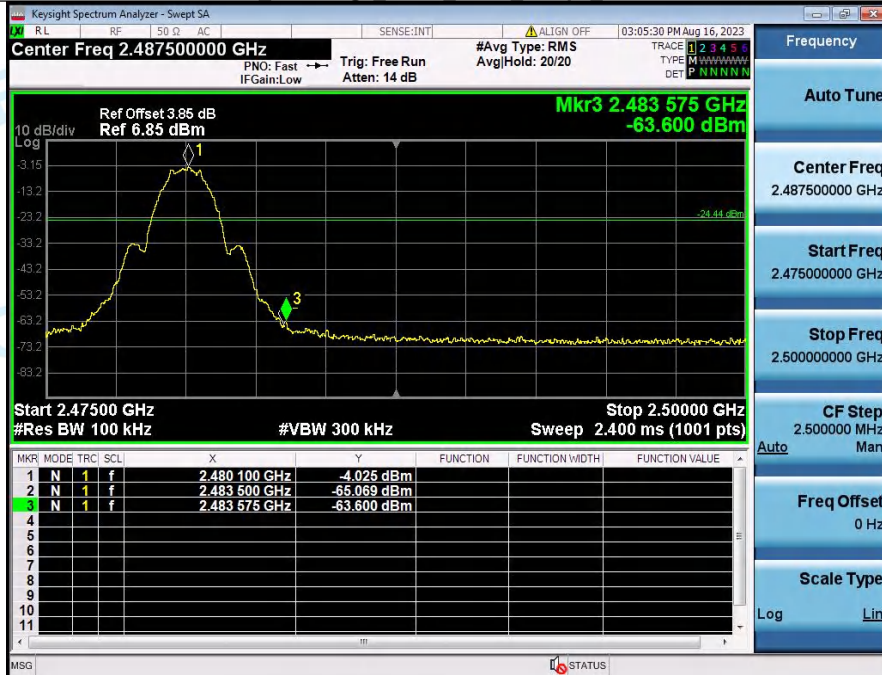



### 3. Peak Output Power

Condition	Antenna	Rate	Frequency (MHz)	Max. Conducted Power(dBm)	Max. Conducted Power(mW)	Limit(mW)	Result
NVNT	ANT1	1Mbps	2402.00	-2.26	0.59	1000	Pass
NVNT	ANT1	1Mbps	2440.00	-1.56	0.70	1000	Pass
NVNT	ANT1	1Mbps	2480	-2.81	0.52	1000	Pass
NVNT	ANT1	2Mbps	2402.00	-2.86	0.52	1000	Pass
NVNT	ANT1	2Mbps	2440.00	-2.02	0.63	1000	Pass
NVNT	ANT1	2Mbps	2480	-2.12	0.61	1000	Pass

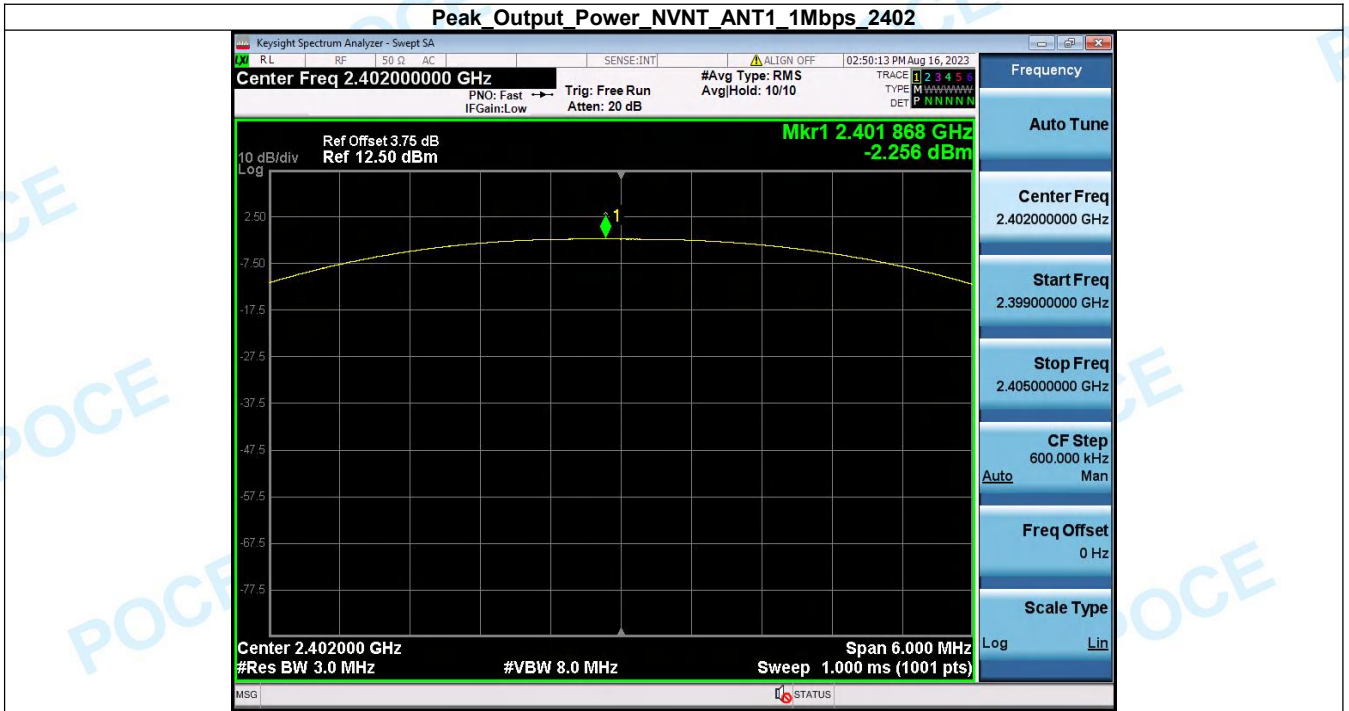



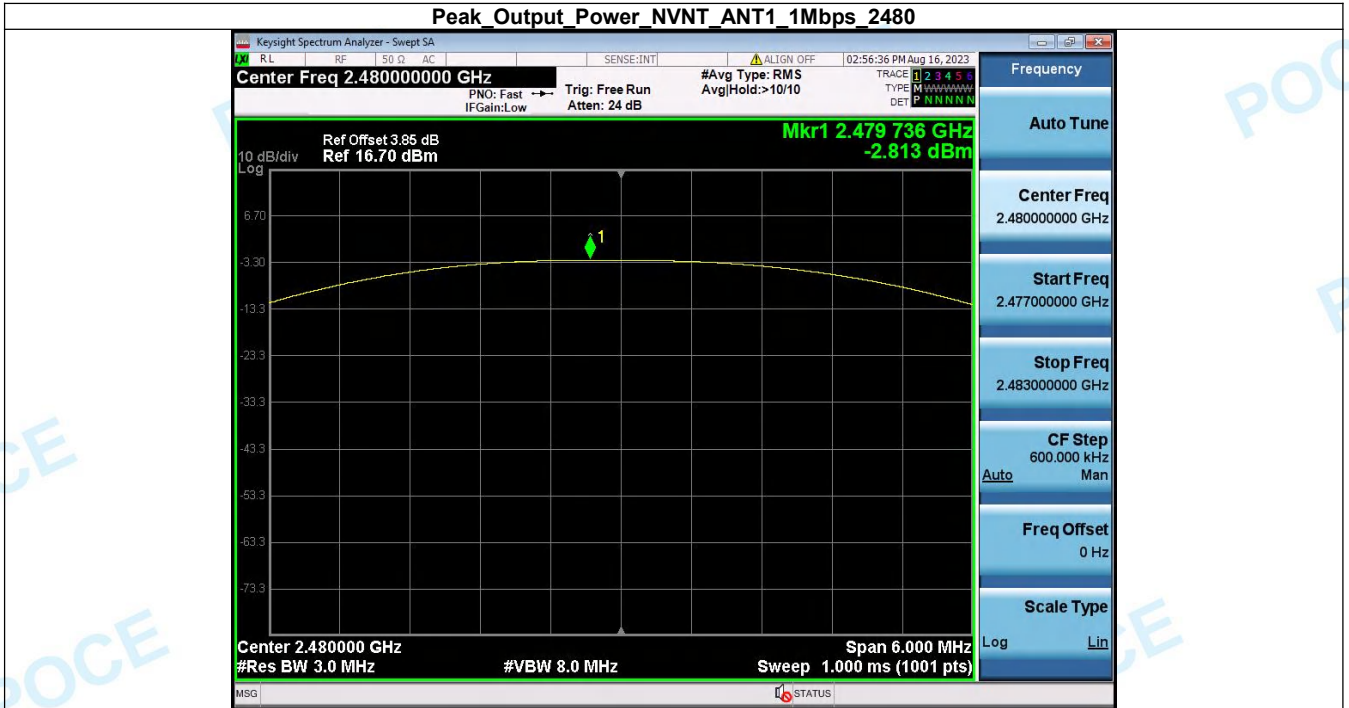

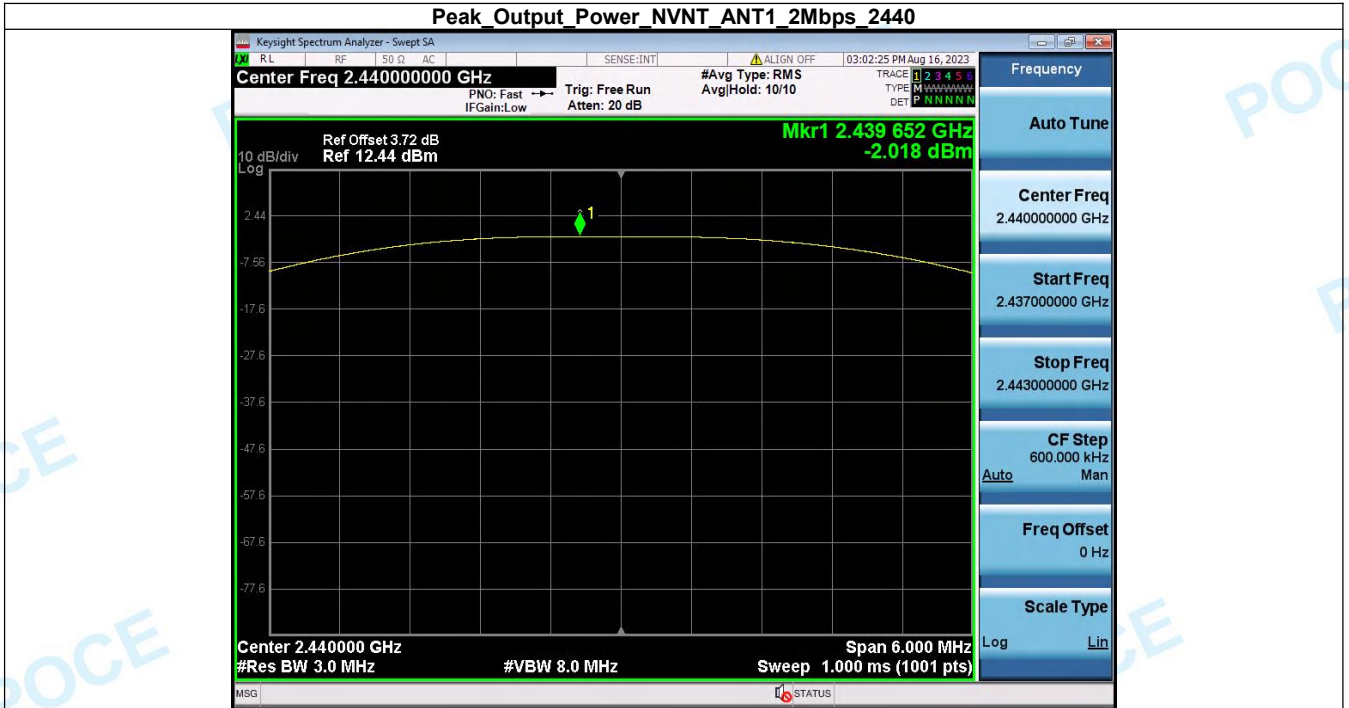

### 4. Power Spectral Density

Condition	Antenna	Rate	Frequency (MHz)	Power Spectral Density(dBm)	Limit(dBm/3kHz)	Result
NVNT	ANT1	1Mbps	2402.00	-14.16	8	Pass
NVNT	ANT1	1Mbps	2440.00	-14.30	8	Pass
NVNT	ANT1	1Mbps	2480	-14.94	8	Pass
NVNT	ANT1	2Mbps	2402.00	-18.59	8	Pass
NVNT	ANT1	2Mbps	2440.00	-17.16	8	Pass
NVNT	ANT1	2Mbps	2480	-16.72	8	Pass

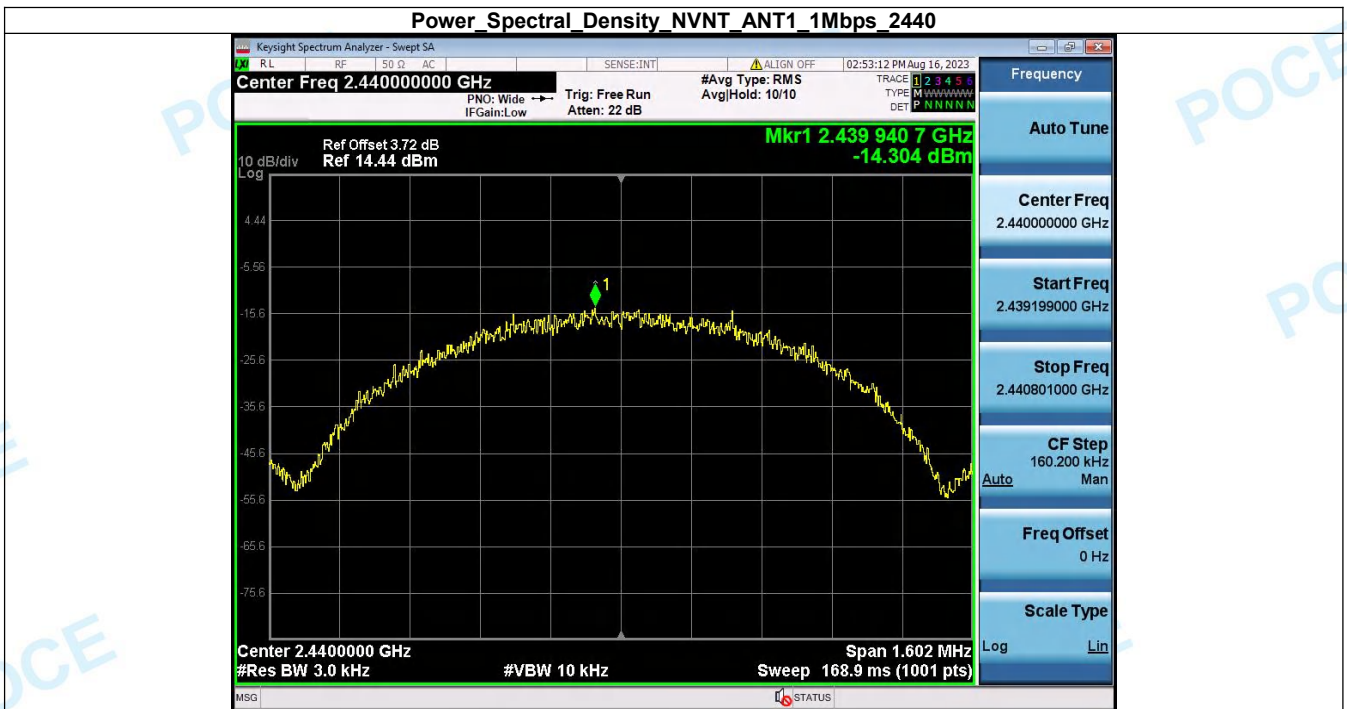
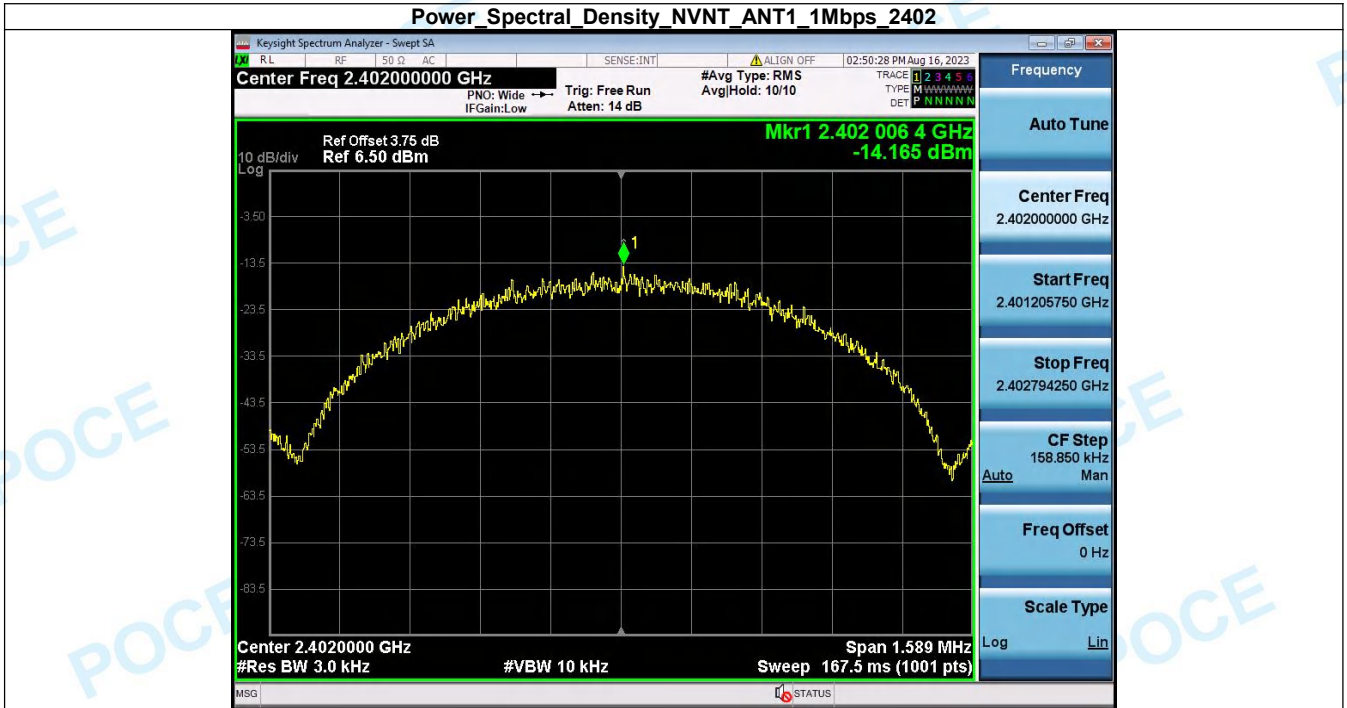



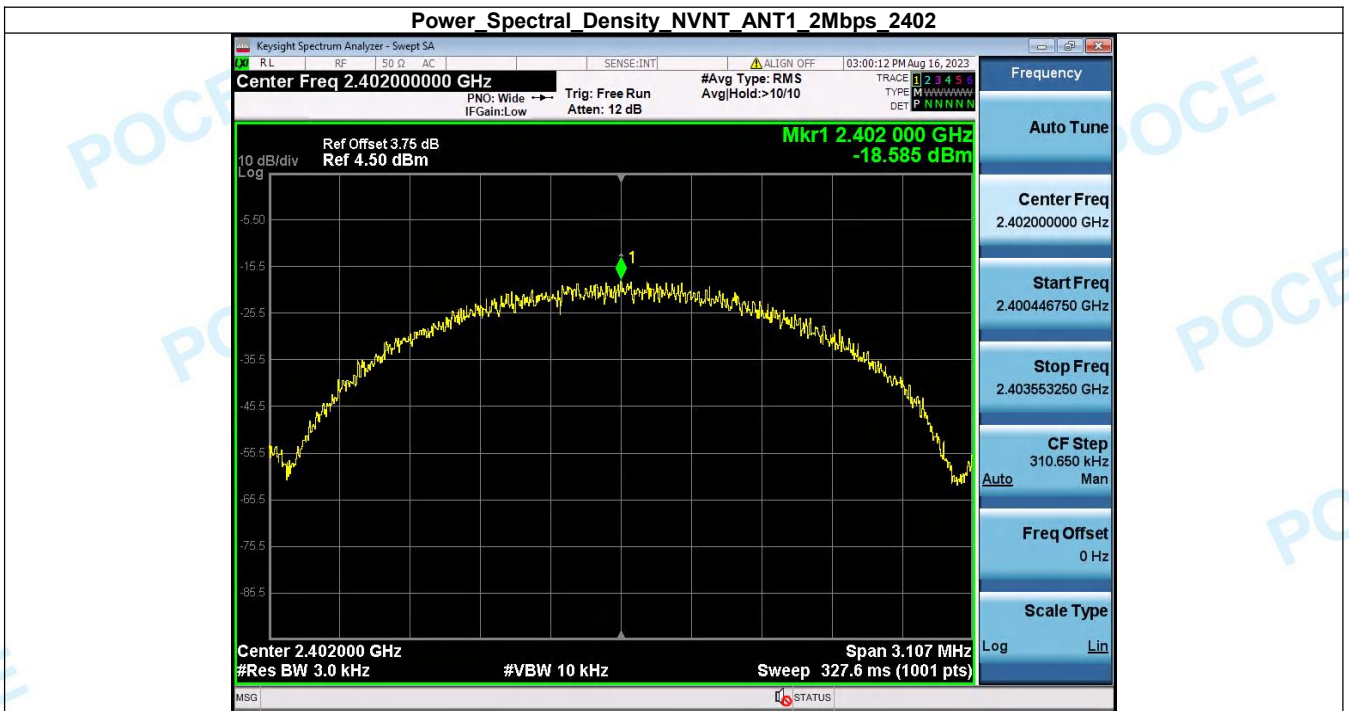
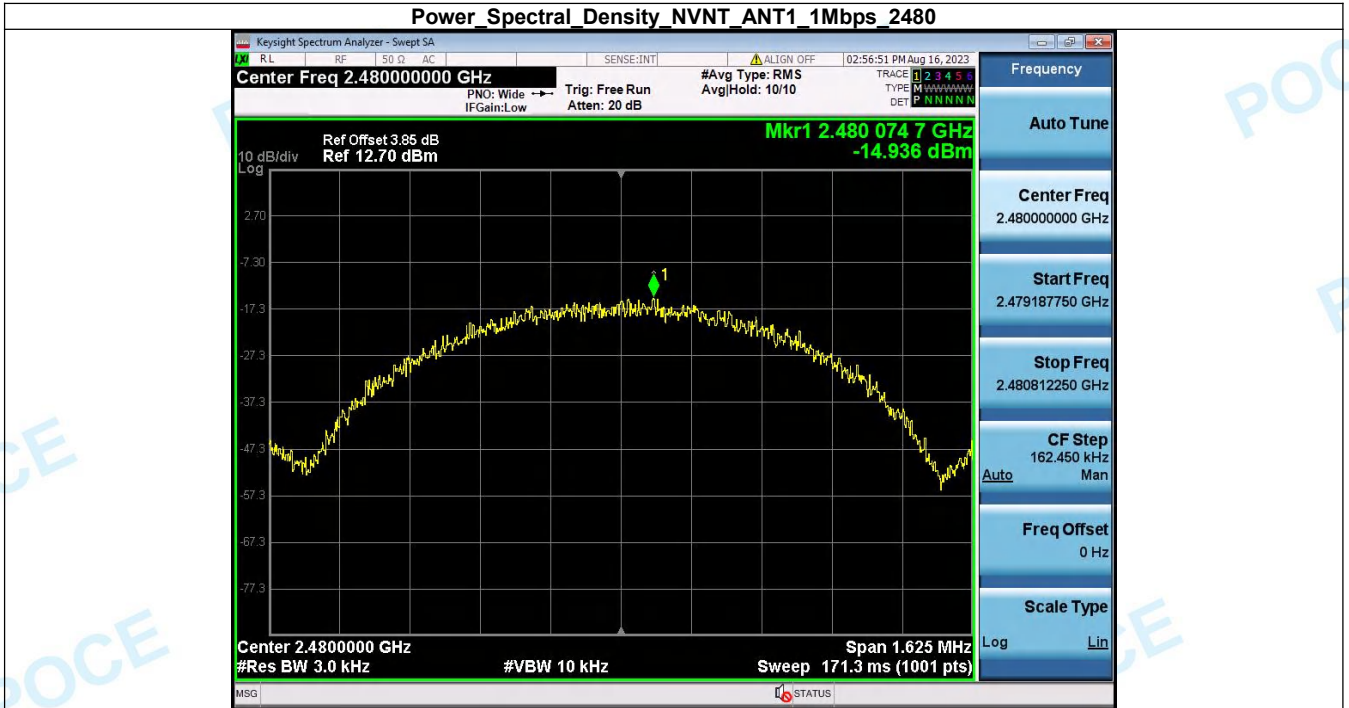



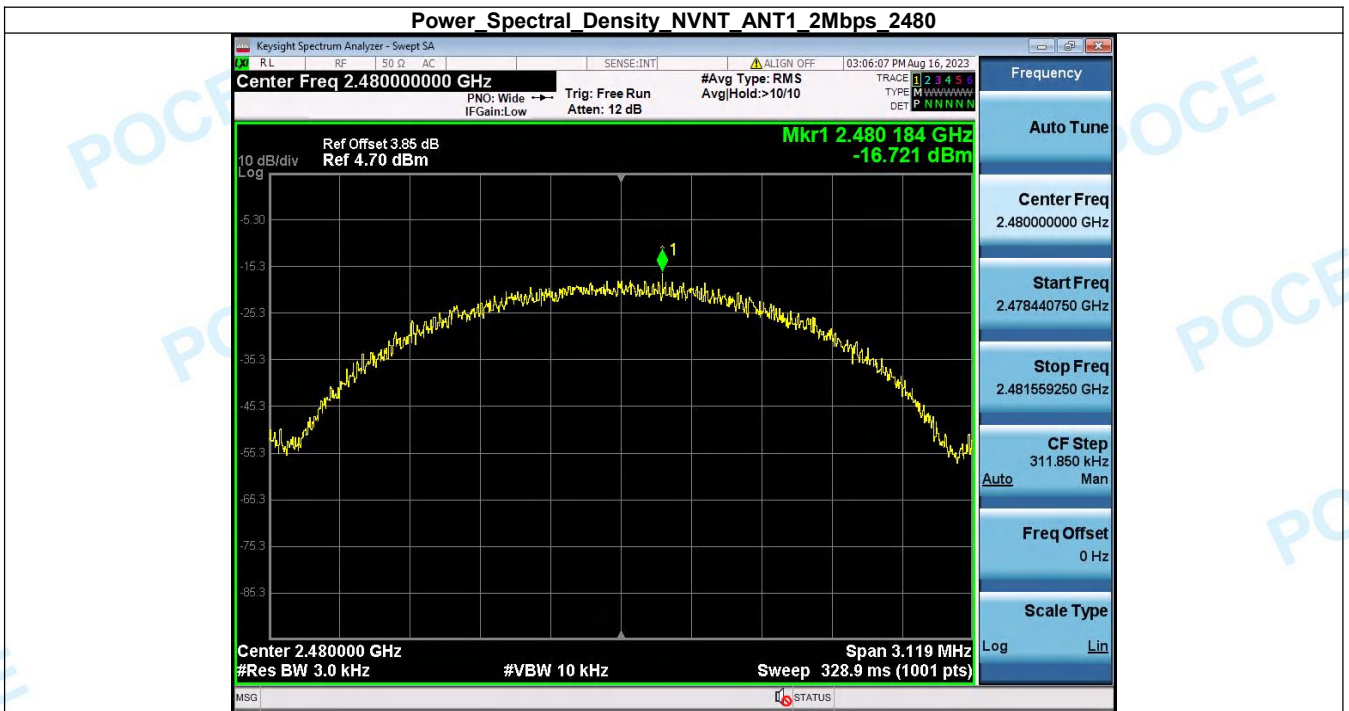
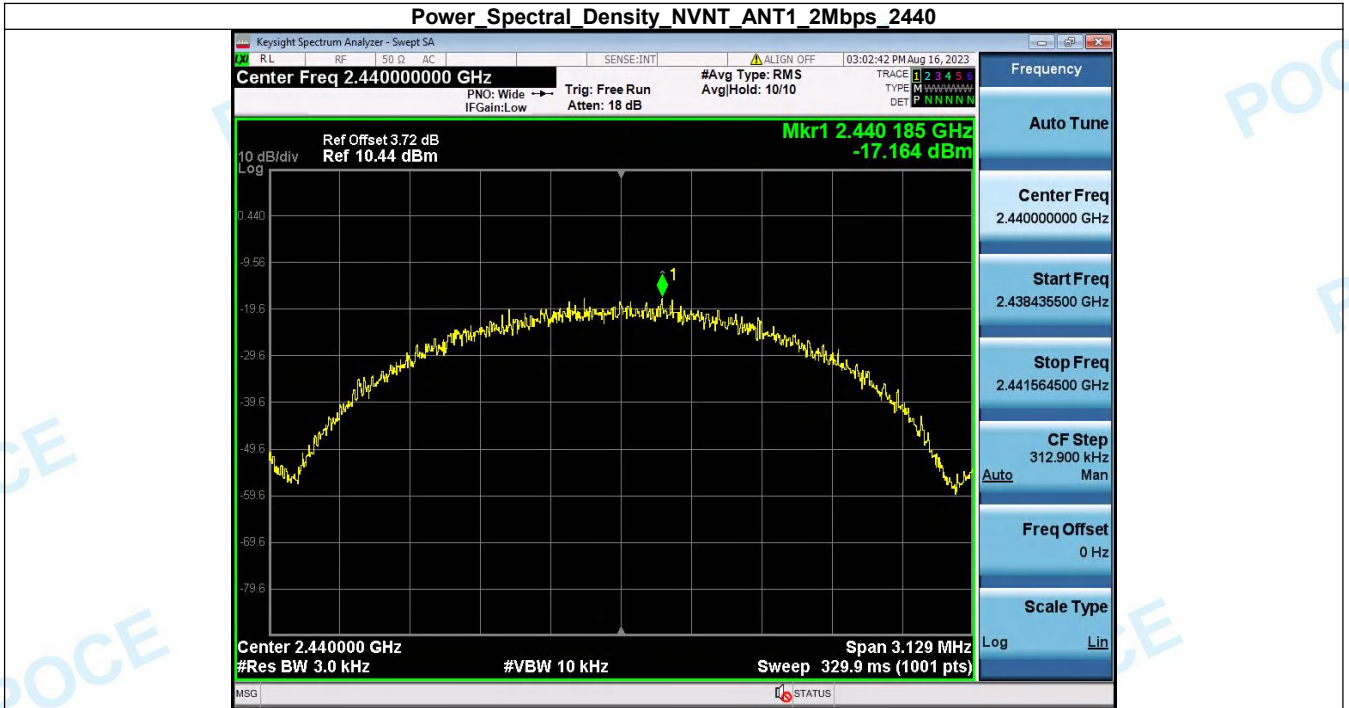

### 5. Spurious Emission

Condition	Antenna	Rate	TX_Frequency(MHz)	Spurious MAX.Value(dBm)	Limit	Result
NVNT	ANT1	1Mbps	2402.00	-55.192	-22.174	Pass
NVNT	ANT1	1Mbps	2440.00	-50.496	-22.683	Pass
NVNT	ANT1	1Mbps	2480	-51.059	-22.970	Pass
NVNT	ANT1	2Mbps	2402.00	-50.855	-23.554	Pass
NVNT	ANT1	2Mbps	2440.00	-57.030	-23.651	Pass
NVNT	ANT1	2Mbps	2480	-53.107	-24.438	Pass

1 Reference Level NVNT\_ANT1\_1Mbps\_2402



2 Spurious Emission NVNT\_ANT1\_1Mbps\_2402

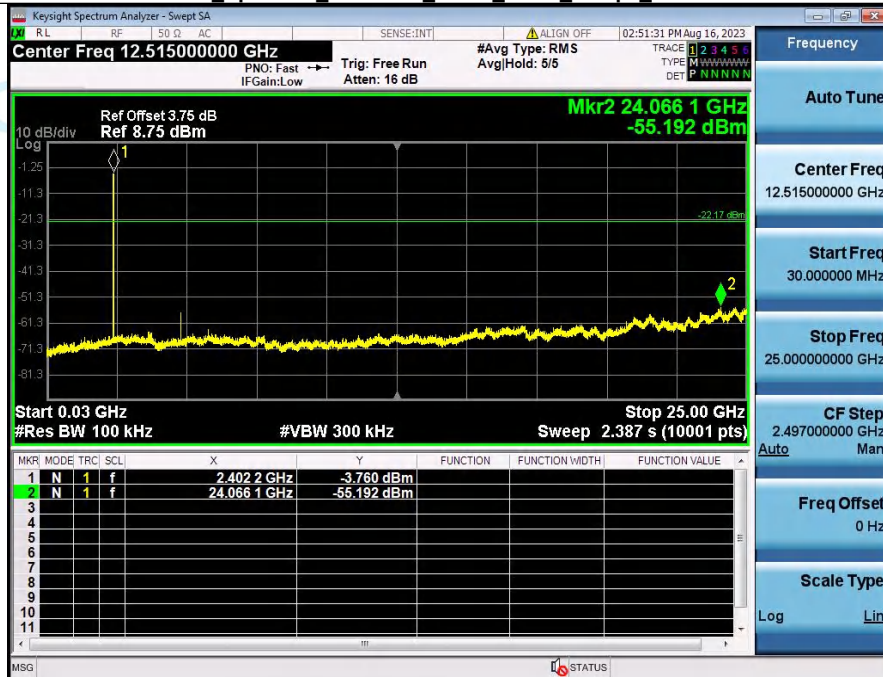

1 Reference Level NVNT ANT1 1Mbps 2440



2 Spurious Emission NVNT ANT1 1Mbps 2440

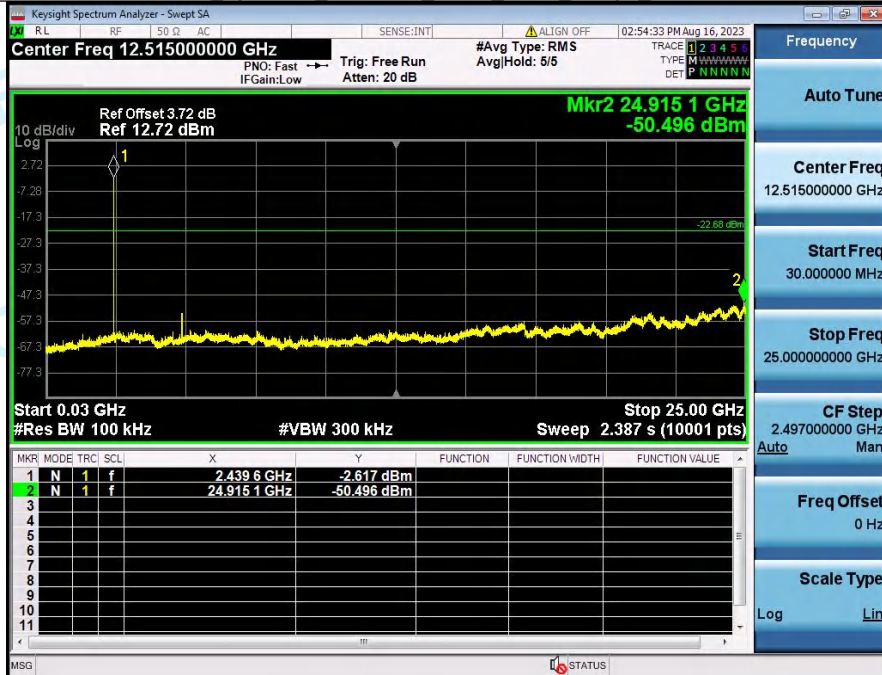



1 Reference Level NVNT ANT1 1Mbps 2480



2 Spurious Emission NVNT ANT1 1Mbps 2480

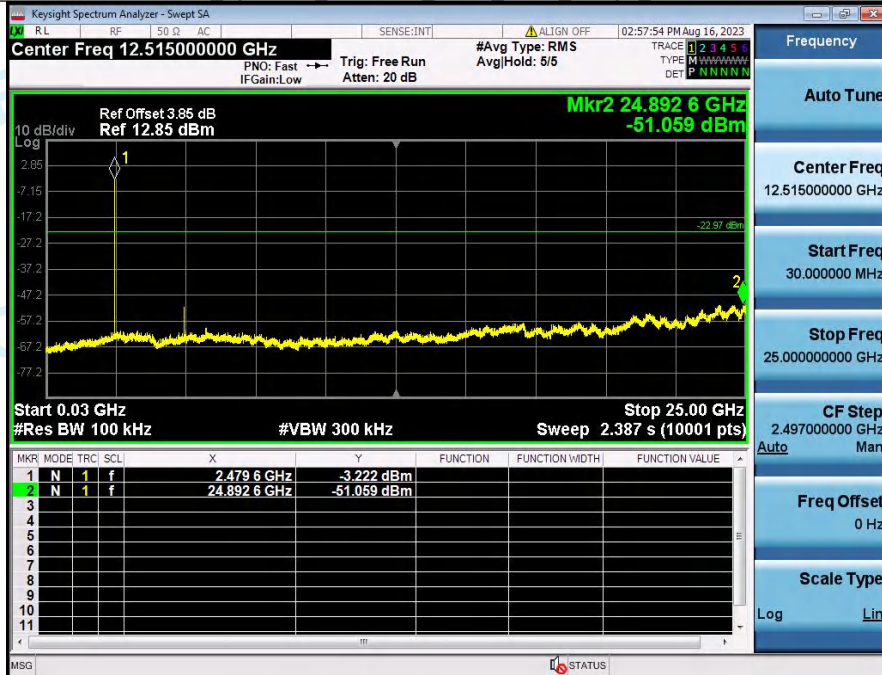



1 Reference Level NVNT ANT1 2Mbps 2402



2 Spurious Emission NVNT ANT1 2Mbps 2402

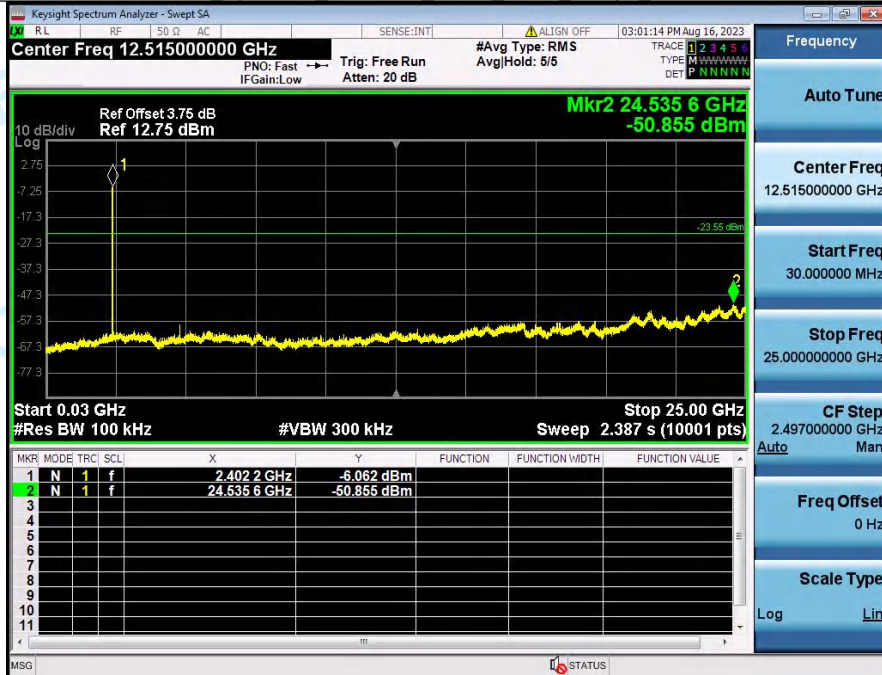

1 Reference Level NVNT ANT1 2Mbps 2440



2 Spurious Emission NVNT ANT1 2Mbps 2440

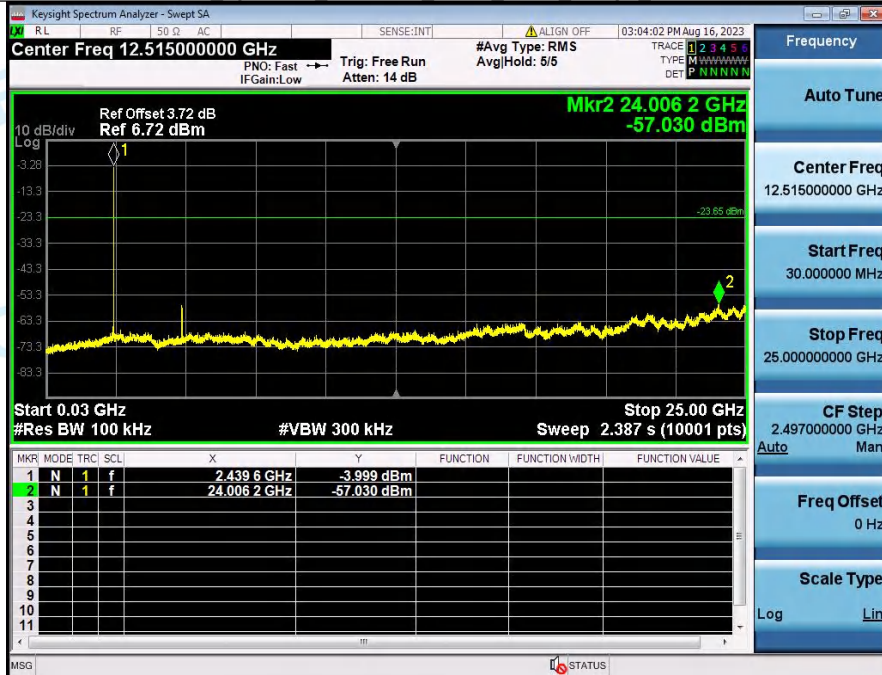

**1 Reference Level NVNT ANT1 2Mbps 2480**



**2 Spurious Emission NVNT ANT1 2Mbps 2480**

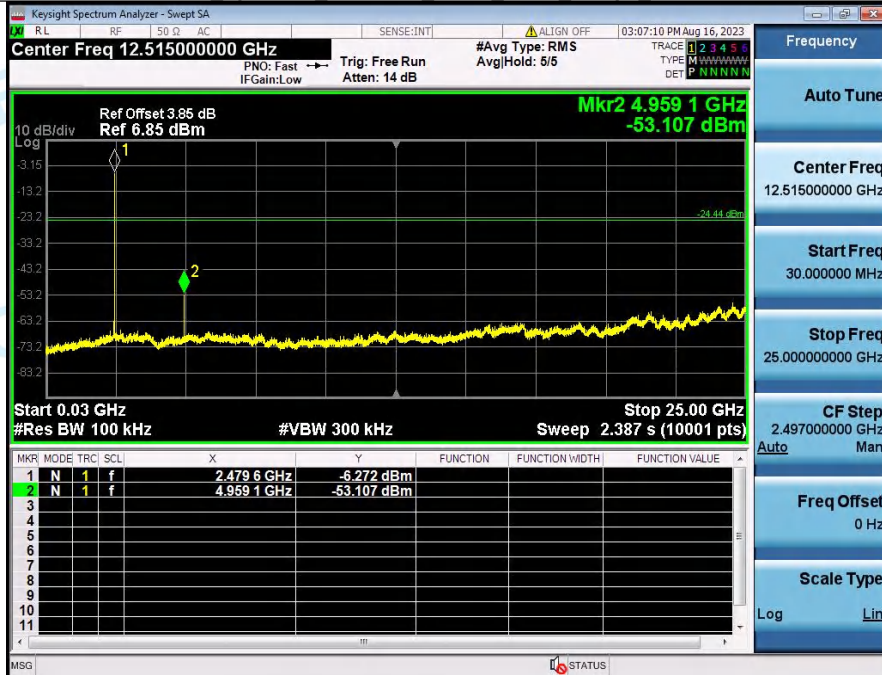

\*\*\*\*\* End of Report \*\*\*\*\*