

FCC Radio Test Report

FCC ID: 2BCGWHS220BLE

Report No. : eLab-FCCP-1-2310G047
Equipment : Kasa Smart Wi-Fi Light Switch Dimmer
Model Name : HS220-LA
Series Model : HS220-BL
Brand Name : tp-link, kasa
Applicant : TP-LINK CORPORATION PTE. LTD.
Address : 7 Temasek Boulevard #29-03 Suntec Tower One, Singapore 038987
Manufacturer : TP-LINK CORPORATION PTE. LTD.
Address : 7 Temasek Boulevard #29-03 Suntec Tower One, Singapore 038987

Radio Function : Bluetooth Low Energy

FCC Rule Part(s) : FCC CFR Title 47, Part 15, Subpart C (15.247)
Measurement Procedure(s) : ANSI C63.10-2013

Date of Receipt : 2023/10/17
Date of Test : 2023/11/14 ~ 2023/11/20
2024/1/6
Issued Date : 2024/1/16

The above equipment has been tested and found in compliance with the requirement of the above standards by eLab Inc.

Prepared by : 
Hunter Chiang, Engineer

Approved by : 
Sam Chuang, Supervisor



eLab Inc.
10F., No. 167, Sec. 2, Datong Rd., Xizhi Dist., New Taipei City 221, Taiwan
Tel: +886-2-8692-6160 Fax: +886-2-8692-6170

Declaration

eLab represents to the client that testing is done in accordance with standard procedures as applicable and that test instruments used has been calibrated with standards traceable to international standard(s) and/or national standard(s).

eLab's reports apply only to the specific samples tested under conditions. It is manufacture's responsibility to ensure that additional production units of this model are manufactured with the identical electrical and mechanical components. **eLab** shall have no liability for any declarations, inferences or generalizations drawn by the client or others from **eLab** issued reports.

This report is the confidential property of the client. As a mutual protection to the clients, the public and ourselves, the test report shall not be reproduced, except in full, without our written approval.

eLab's laboratory quality assurance procedures are in compliance with the **ISO/IEC 17025** requirements, and accredited by the conformity assessment authorities listed in this test report.

eLab is not responsible for the sampling stage, so the results only apply to the sample as received.

The information, data and test plan are provided by manufacturer which may affect the validity of results, so it is manufacturer's responsibility to ensure that the apparatus meets the essential requirements of applied standards and in all the possible configurations as representative of its intended use.

Limitation

For the use of the authority's logo is limited unless the Test Standard(s)/Scope(s)/Item(s) mentioned in this test report is (are) included in the conformity assessment authorities acceptance respective.

Please note that the measurement uncertainty is provided for informational purpose only and are not use in determining the Pass/Fail results.

CONTENTS

REVISION HISTORY	5
1 SUMMARY OF TEST RESULTS	6
1.1 TEST FACILITY	7
1.2 MEASUREMENT UNCERTAINTY	7
1.3 TEST ENVIRONMENT CONDITIONS	7
1.4 TABLE OF PARAMETERS OF TEXT SOFTWARE SETTING	8
2 GENERAL INFORMATION	9
2.1 DESCRIPTION OF EUT	9
2.2 TEST MODES	11
2.3 BLOCK DIAGRAM SHOWING THE CONFIGURATION OF SYSTEM TESTED	12
2.4 SUPPORT UNITS	12
3 AC POWER LINE CONDUCTED EMISSIONS TEST	13
3.1 LIMIT	13
3.2 TEST PROCEDURE	13
3.3 TEST SETUP	14
3.4 TEST RESULT	14
4 RADIATED EMISSIONS TEST	15
4.1 LIMIT	15
4.2 TEST PROCEDURE	16
4.3 TEST SETUP	16
4.4 EUT OPERATING CONDITIONS	18
4.5 TEST RESULT – BELOW 30 MHZ	18
4.6 TEST RESULT – 30 MHZ TO 1 GHZ	18
4.7 TEST RESULT – ABOVE 1 GHZ	18
5 BANDWIDTH TEST	19
5.1 APPLIED PROCEDURES / LIMIT	19
5.2 TEST PROCEDURE	19
5.3 TEST SETUP	19
5.4 EUT OPERATION CONDITIONS	19
5.5 TEST RESULTS	19
6 OUTPUT POWER TEST	20
6.1 APPLIED PROCEDURES / LIMIT	20
6.2 TEST PROCEDURE	20
6.3 TEST SETUP	20
6.4 EUT OPERATION CONDITIONS	20
6.5 TEST RESULTS	20
7 POWER SPECTRAL DENSITY TEST	21
7.1 APPLIED PROCEDURES / LIMIT	21
7.2 TEST PROCEDURE	21
7.3 TEST SETUP	21
7.4 EUT OPERATION CONDITIONS	21
7.5 TEST RESULTS	21
8 ANTENNA CONDUCTED SPURIOUS EMISSION	22
8.1 APPLIED PROCEDURES / LIMIT	22
8.2 TEST PROCEDURE	22
8.3 TEST SETUP	22
8.4 EUT OPERATION CONDITIONS	22

8.5	TEST RESULTS	22
9	LIST OF MEASURING EQUIPMENTS	23
10	EUT TEST PHOTO	25
11	EUT PHOTOS	25
APPENDIX A	AC POWER LINE CONDUCTED EMISSIONS	26
APPENDIX B	RADIATED EMISSIONS - 30 MHZ TO 1 GHZ	31
APPENDIX C	ADIATED EMISSIONS - ABOVE 1 GHZ	34
APPENDIX D	BANDWIDTH	43
APPENDIX E	OUTPUT POWER	45
APPENDIX F	POWER SPECTRAL DENSITY TEST	47
APPENDIX G	ANTENNA CONDUCTED SPURIOUS EMISSION	49

REVISION HISTORY

Report No.	Version	Description	Issued Date	Note
eLab-FCCP-1-2310G047	R00	Original Report.	2023/12/14	Invalid
eLab-FCCP-1-2310G047	R01	1. Added note 3 in page 6. 2. Updated the section 6.3.	2023/12/27	Invalid
eLab-FCCP-1-2310G047	R02	1. Updated the test address. 2. Updated the output power.	2024/1/8	Invalid
eLab-FCCP-1-2310G047	R03	Updated applicant and manufacturer information.	2024/1/16	Valid

1 SUMMARY OF TEST RESULTS

Test procedures according to the technical standards.

Standard(s) Section	Description	Result	Remark
15.207	AC Power Line Conducted Emissions	Pass	-----
15.205 15.209 15.247(d)	Radiated Emissions	Pass	-----
15.247(a)(2)	Bandwidth	Pass	-----
15.247(b)(3)	Output Power	Pass	-----
15.247(e)	Power Spectral Density	Pass	-----
15.247(d)	Antenna conducted Spurious Emission	Pass	-----
15.203	Antenna Requirement	Pass	Note(3)

NOTE:

- (1) "N/A" denotes test is not applicable in this Test Report.
- (2) The report format version is FR15CBT4.0_V1.0
- (3) The device what use a permanently attached antenna were considered sufficient to comply with the provisions of 15.203.

1.1 TEST FACILITY

The test facilities used to collect the test data in this report:

No.64, Ln. 169, Sec. 2, Datong Rd., Xizhi Dist., New Taipei City

The test sites and facilities are covered under FCC RN: 681248 and DN: TW4045.

C01 CB01 TR01

1.2 MEASUREMENT UNCERTAINTY

The reported uncertainty of measurement $y \pm U$, where expanded uncertainty U is based on a standard uncertainty multiplied by a coverage factor of $k = 2$, providing a level of confidence of approximately **95 %**.

The measurement instrumentation uncertainty considerations contained in CISPR 16-4-2. The eLab measurement uncertainty is less than the CISPR 16-4-2 U_{cispr} requirement.

A. AC power line conducted emissions test:

Test Site	Method	Measurement Frequency Range	U (dB)
C01	CISPR	150 kHz ~ 30MHz	3.44

B. Radiated emissions test :

Test Site	Measurement Frequency Range	U,(dB)
CB01	0.03 GHz ~ 0.2 GHz	4.4417
	0.2 GHz ~ 1 GHz	4.5567
	1 GHz ~ 6 GHz	3.9930
	6 GHz ~ 18 GHz	4.4555
	18 GHz ~ 26 GHz	3.8333
	26 GHz ~ 40 GHz	3.8241

C. Conducted test :

Test Item	U,(dB)
Occupied Bandwidth	1.0502
Output power	1.0406
Power Spectral Density	1.0502
Conducted Spurious emissions	1.1484
Conducted Band edges	1.0518

NOTE:

Unless specifically mentioned, the uncertainty of measurement has not been taken into account to declare the compliance or non-compliance to the specification.

1.3 TEST ENVIRONMENT CONDITIONS

Test Item	Environment Condition	Test Voltage	Tested by
AC Power Line Conducted Emissions	25 °C, 60 %	DC 5V	Hunter Chiang
Radiated emissions (30MHz TO 1000MHz)	Refer to data	DC 5V	Hunter Chiang
Radiated emissions (Above 1GHz)	Refer to data	DC 5V	Hunter Chiang
Bandwidth	24 °C, 60 %	DC 5V	Hunter Chiang
Output Power	24 °C, 60 %	DC 5V	Hunter Chiang
Power Spectral Density	24 °C, 60 %	DC 5V	Hunter Chiang
Antenna conducted Spurious Emission	24 °C, 60 %	DC 5V	Hunter Chiang

1.4 TABLE OF PARAMETERS OF TEXT SOFTWARE SETTING

Test Software	RTLBTAPP 5.2.2.40			
Modulation Mode	2402 MHz	2440 MHz	2480 MHz	Data Rate
BLE	0x2F	0x2F	0x2F	1 Mbps

2 GENERAL INFORMATION

2.1 DESCRIPTION OF EUT

Equipment	Kasa Smart Wi-Fi Light Switch Dimmer
Model Name	HS220-LA
Series Model	HS220-BL
Model Difference(s)	Only differ in model name and colour, HS220-LA is light apricot, HS220-BL is black, and everything else is exactly the same.
Brand Name	tp-link, kasa
Serial Number	N/A
Power Source	AC Mains.
Power Rating	120V ~ 60Hz 300W Incandescent/Halogen 150W LED
Operation Band	2400 MHz ~ 2483.5 MHz
Operation Frequency	2402 MHz ~ 2480 MHz
Modulation Technology	GFSK
Transfer Rate	1 Mbps
Output Power Max.	1 Mbps: 7.50 dBm (0.0056 W)

NOTE:

- (1) The above EUT information is declared by manufacturer and for more detailed features description, please refers to the manufacturer's specifications or user's manual.

(2) Channel List:

Channel	Frequency (MHz)	Channel	Frequency (MHz)
00	2402	20	2442
01	2404	21	2444
02	2406	22	2446
03	2408	23	2448
04	2410	24	2450
05	2412	25	2452
06	2414	26	2454
07	2416	27	2456
08	2418	28	2458
09	2420	29	2460
10	2422	30	2462
11	2424	31	2464
12	2426	32	2466
13	2428	33	2468
14	2430	34	2470
15	2432	35	2472
16	2434	36	2474
17	2436	37	2476
18	2438	38	2478
19	2440	39	2480

(3) Table for Filed Antenna:

Manufacturer	P/N	Type	Frequency (MHz)	Gain (dBi)
BIG FIELD GLOBAL PTE. LTD	6035500141	PIFA	2400-2500	2.98

(4) The above Antenna information are derived from the antenna data sheet provided by manufacturer and for more detailed features description, please refer to the manufacturer's specifications, the laboratory shall not be held responsible.

2.2 TEST MODES

Test Items	Test mode	Channel	Note
AC power line conducted emissions	Normal/Idle	-	-
Transmitter Radiated Emissions (below 1GHz)	1 Mbps	19	-
Transmitter Radiated Emissions (above 1GHz)	1 Mbps	00/39	Bandedge
	1 Mbps	00/19/39	Harmonic
Bandwidth	1 Mbps	00/19/39	-
Output Power	1 Mbps	00/19/39	-
Power Spectral Density	1 Mbps	00/19/39	-
Antenna conducted Spurious Emission	1 Mbps	00/19/39	-

NOTE:

- (1) For radiated emission band edge test, both Vertical and Horizontal are evaluated, but only the worst case (Horizontal) is recorded.

2.3 BLOCK DIAGRAM SHOWING THE CONFIGURATION OF SYSTEM TESTED

Equipment letters and Cable numbers refer to item numbers described in the tables of clause 2.4.

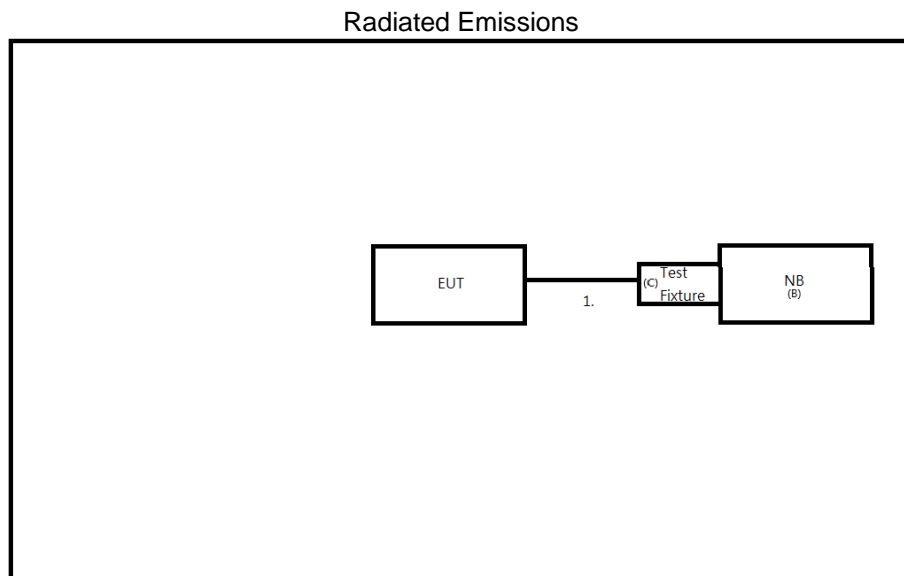
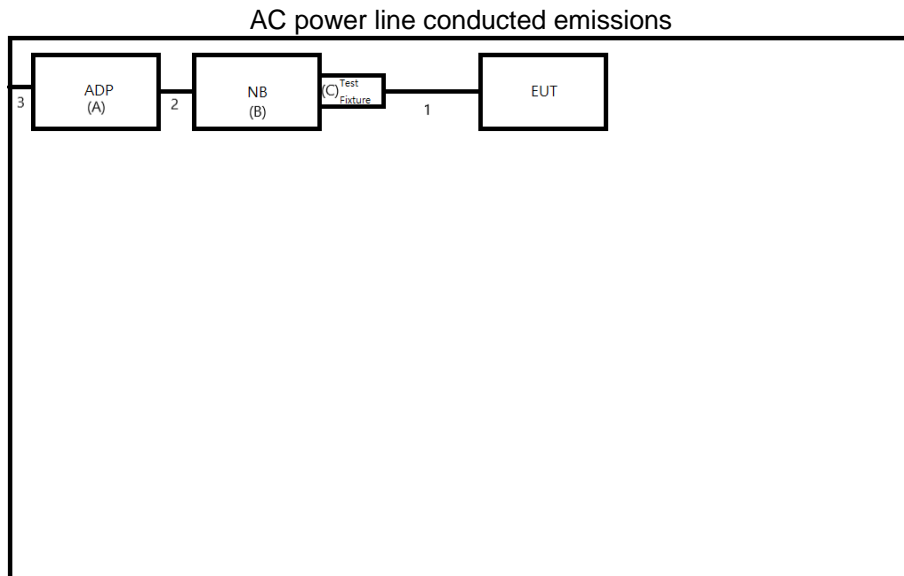

2.4 SUPPORT UNITS

Item	Equipment	Brand	Model No.	Remarks
A	ADP	TOSHIBA	PA5279E-1AC3	Supplied by test lab.
B	NB	Dynabook	TECRA A40-J	Supplied by test lab.
C	Test Fixture	N/A	FT232RL	Supplied by test lab.

Item	Cable Type	Ferrite Core	Length	Shielded	Remarks
1	USB Cable	NO	0.1m	NO	Supplied by test lab.
2	DC Cable	YES	1.5m	NO	Supplied by test lab.
3	AC Cable	NO	1m	NO	Supplied by test lab.

3 AC POWER LINE CONDUCTED EMISSIONS TEST

3.1 LIMIT

Frequency (MHz)	Limit (dB μ V)	
	Quasi-peak	Average
0.15 - 0.5	66 - 56 *	56 - 46 *
0.50 - 5.0	56	46
5.0 - 30.0	60	50

NOTE:

- (1) The tighter limit applies at the band edges.
- (2) The limit of " * " marked band means the limitation decreases linearly with the logarithm of the frequency in the range.
- (3) The test result calculated as following:
 Measurement Value = Reading Level + Correct Factor
 Correct Factor = Insertion Loss + Cable Loss + Attenuator Factor (if use)
 Margin Level = Measurement Value – Limit Value
 Calculation example:

Reading Level		Correct Factor		Measurement Value
38.22	+	3.45	=	41.67

Measurement Value		Limit Value		Margin Level
41.67	-	60	=	-18.33

The following table is the setting of the receiver.

Receiver Parameter	Setting
Attenuation	10 dB
Start Frequency	0.15 MHz
Stop Frequency	30 MHz
IF Bandwidth	9 KHz

3.2 TEST PROCEDURE

- a. The EUT was placed 0.8 m above the horizontal ground plane with the EUT being connected to the power mains through a line impedance stabilization network (LISN).
 All other support equipment were powered from an additional LISN(s).
 The LISN provides 50 Ohm/50uH of impedance for the measuring instrument.
- b. Interconnecting cables that hang closer than 40 cm to the ground plane shall be folded back and forth in the center forming a bundle to keep the cable above 40 cm.
- c. Excess I/O cables that are not connected to a peripheral shall be bundled in the center.
 The end of the cable will be terminated, using the correct terminating impedance.
 The overall length shall not exceed 1 m.
- d. The LISN is spaced at least 80 cm from the nearest part of the EUT chassis.
- e. For the actual test configuration, please refer to the related Item – EUT TEST PHOTO.

NOTE:

- (1) In the results, each reading is marked as Peak, QP or AVG per the detector used.
 BW=9 kHz (6 dB Bandwidth)
- (2) All readings are Peak unless otherwise stated QP or AVG in column of Note. Both the QP and the AVG readings must be less than the limit for compliance.

3.3 TEST SETUP

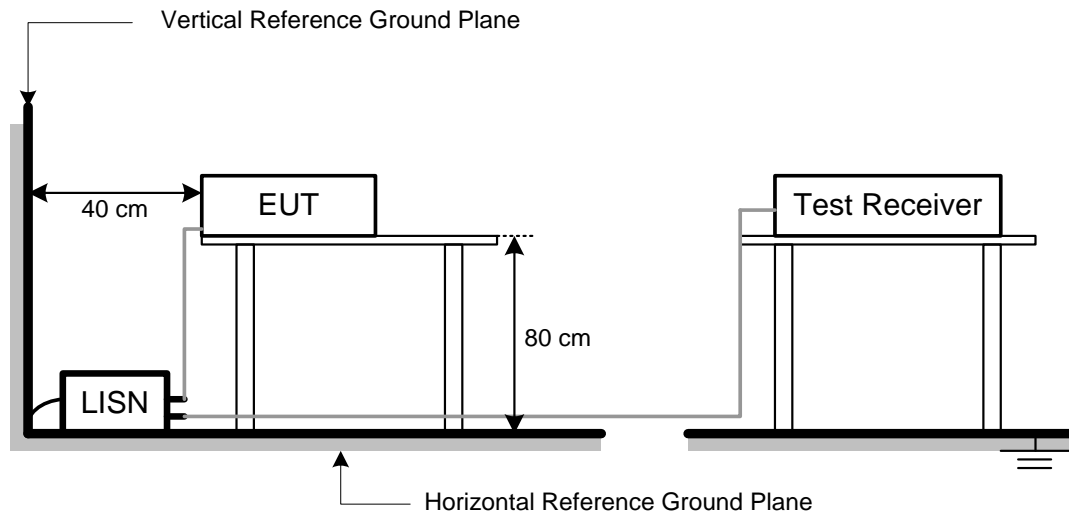

3.4 TEST RESULT

Please refer to the **APPENDIX A**.

4 RADIATED EMISSIONS TEST

4.1 LIMIT

In case the emission fall within the restricted band specified on 15.205, then the 15.209 limit in the table below has to be followed.

LIMITS OF RADIATED EMISSIONS MEASUREMENT (9 kHz to 1000 MHz)

Frequency (MHz)	Field Strength (microvolts/meter)	Measurement Distance (meters)
0.009~0.490	2400/F(KHz)	300
0.490~1.705	24000/F(KHz)	30
1.705~30.0	30	30
30~88	100	3
88~216	150	3
216~960	200	3
960~1000	500	3

LIMITS OF RADIATED EMISSIONS MEASUREMENT (Above 1000 MHz)

Frequency (MHz)	Radiated Emissions (dBuV/m)		Measurement Distance (meters)
	Peak	Average	
Above 1000	74	54	3

NOTE:

- (1) The limit for radiated test was performed according to FCC CFR Title 47, Part 15, Subpart C.
- (2) The tighter limit applies at the band edges.
- (3) Emission level (dBuV/m)=20log Emission level (uV/m).
- (4) The test result calculated as following:
 Measurement Value = Reading Level + Correct Factor
 Correct Factor = Antenna Factor + Cable Loss - Amplifier Gain(if use)
 Margin Level = Measurement Value - Limit Value
 Calculation example:

Reading Level		Correct Factor		Measurement Value
41.91	+	-8.36	=	33.55

Measurement Value		Limit Value		Margin Level
33.55	-	43.50	=	-9.95

Spectrum Parameter	Setting
Attenuation	Auto
Start Frequency	1000 MHz
Stop Frequency	10th carrier harmonic
RBW / VBW (Emission in restricted band)	1MHz / 3MHz for Peak, 1MHz / 1/T for Average

Spectrum Parameter	Setting
Attenuation	Auto
Start ~ Stop Frequency	9KHz~90KHz for PK/AVG detector
Start ~ Stop Frequency	90KHz~110KHz for QP detector
Start ~ Stop Frequency	110KHz~490KHz for PK/AVG detector
Start ~ Stop Frequency	490KHz~30MHz for QP detector
Start ~ Stop Frequency	30MHz~1000MHz for QP detector

4.2 TEST PROCEDURE

- a. The measuring distance of 3 m shall be used for measurements. The EUT was placed on the top of a rotating table 0.8 meter above the ground at a 3 meter semi-anechoic chamber. The table was rotated 360 degrees to determine the position of the highest radiation.(below 1GHz)
- b. The measuring distance of 3 m shall be used for measurements. The EUT was placed on the top of a rotating table 1.5 meter above the ground at a 3 meter semi-anechoic chamber. The table was rotated 360 degrees to determine the position of the highest radiation.(above 1GHz)
- c. The height of the equipment or of the substitution antenna shall be 0.8 m or 1.5 m, the height of the test antenna shall vary between 1 m to 4 m. Both horizontal and vertical polarizations of the antenna are set to make the measurement.
- d. For each suspected emission, the EUT was arranged to its worst case and then the antenna was tuned to heights find the maximum reading (used Bore sight function).
- e. The receiver system was set to peak and average detect function and specified bandwidth with maximum hold mode when the test frequency is above 1GHz.
- f. The initial step in collecting radiated emission data is a receiver peak detector mode pre-scanning the measurement frequency range. Significant peaks are then marked and then Quasi Peak detector mode re-measured.
- g. All readings are Peak unless otherwise stated QP in column of Note. Peak denotes that the Peak reading compliance with the QP Limits and then QP Mode measurement didn't perform. (below 1GHz)
- h. All readings are Peak Mode value unless otherwise stated AVG in column of Note. If the Peak Mode Measured value compliance with the Peak Limits and lower than AVG Limits, the EUT shall be deemed to meet both Peak & AVG Limits and then only Peak Mode was measured, but AVG Mode didn't perform. (above 1GHz)
- i. For the actual test configuration, please refer to the related Item – EUT TEST PHOTO.

4.3 TEST SETUP

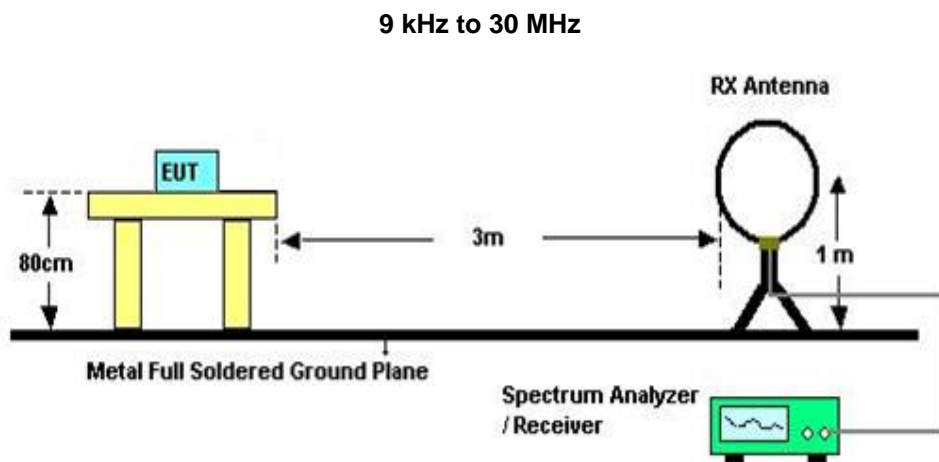

30 MHz to 1 GHz

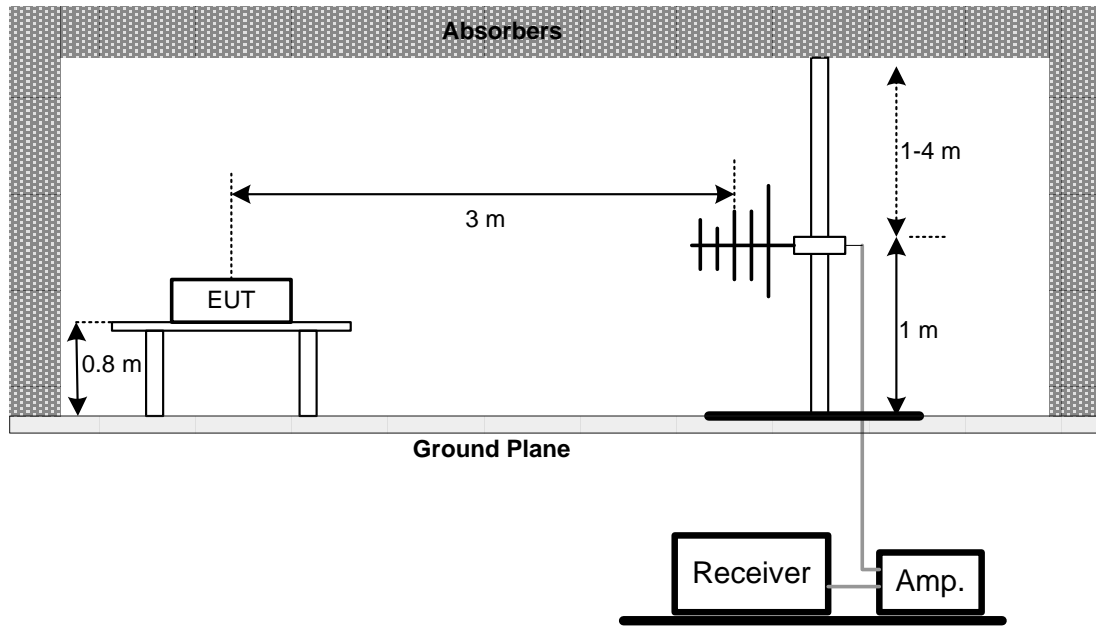

Above 1 GHz

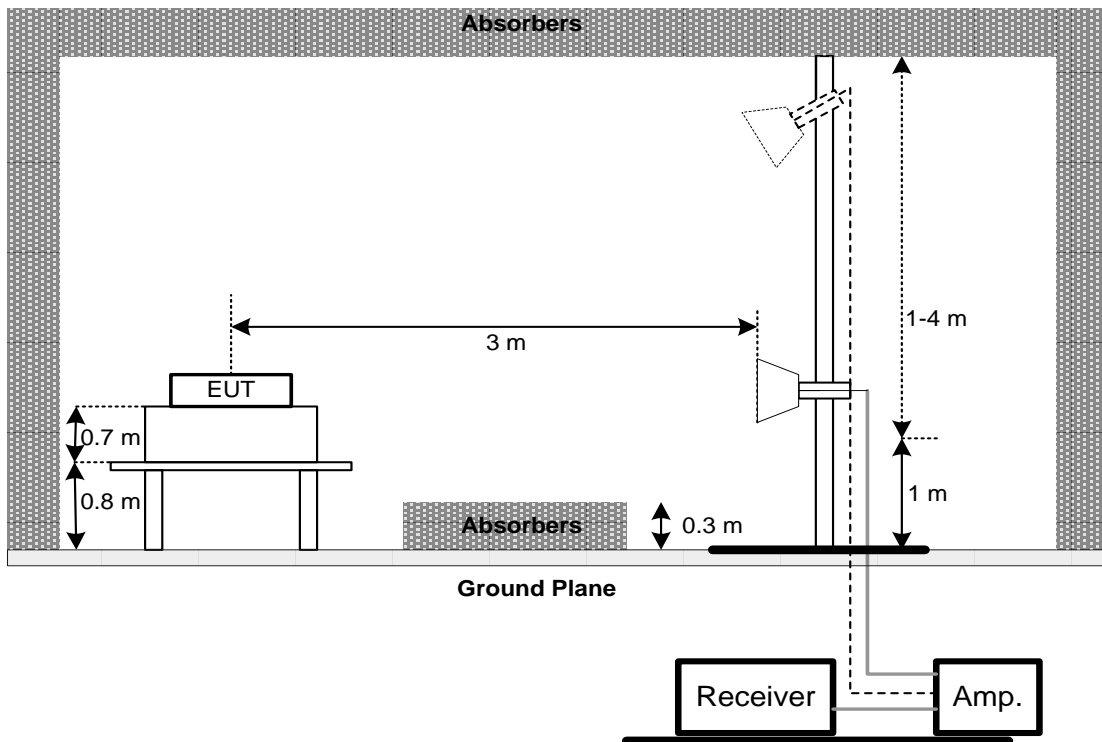

4.4 EUT OPERATING CONDITIONS

The EUT was programmed to be in continuously transmitting mode.

4.5 TEST RESULT – BELOW 30 MHZ

There were no emissions found below 30 MHz within 20 dB of the limit.

4.6 TEST RESULT – 30 MHZ TO 1 GHZ

Please refer to the APPENDIX B.

4.7 TEST RESULT – ABOVE 1 GHZ

Please refer to the APPENDIX C.

NOTE:

- (1) No limit: This is fundamental signal, the judgment is not applicable.
For fundamental signal judgment was referred to Peak output test.

5 BANDWIDTH TEST

5.1 APPLIED PROCEDURES / LIMIT

FCC Part15 (15.247) , Subpart C				
Section	Test Item	Limit	Frequency Range (MHz)	Result
15.247(a)(2)	Bandwidth	$\geq 500\text{KHz}$ (6dB bandwidth)	2400-2483.5	PASS

5.2 TEST PROCEDURE

- a. The EUT was directly connected to the spectrum analyzer and antenna output port as show in the block diagram below,
- b. Spectrum Setting : RBW= 100KHz, VBW=300KHz, Sweep time = 2.5 ms.

5.3 TEST SETUP



5.4 EUT OPERATION CONDITIONS

The EUT was programmed to be in continuously transmitting mode.

5.5 TEST RESULTS

Please refer to the APPENDIX D.

6 OUTPUT POWER TEST

6.1 APPLIED PROCEDURES / LIMIT

FCC Part15 (15.247) , Subpart C				
Section	Test Item	Limit	Frequency Range (MHz)	Result
15.247(b)(3)	Maximum Output Power	1 watt or 30dBm	2400-2483.5	PASS

6.2 TEST PROCEDURE

- a. The EUT was directly connected to the spectrum analyzer and antenna output port as show in the block diagram below.
- b. The maximum peak conducted output power was performed in accordance with FCC KDB 558074 D01 15.247 Meas Guidance.

6.3 TEST SETUP



6.4 EUT OPERATION CONDITIONS

The EUT was programmed to be in continuously transmitting mode.

6.5 TEST RESULTS

Please refer to the APPENDIX E.

7 POWER SPECTRAL DENSITY TEST

7.1 APPLIED PROCEDURES / LIMIT

FCC Part15 (15.247) , Subpart C				
Section	Test Item	Limit	Frequency Range (MHz)	Result
15.247(e)	Power Spectral Density	8 dBm (in any 3KHz)	2400-2483.5	PASS

7.2 TEST PROCEDURE

- a. The EUT was directly connected to the spectrum analyzer and antenna output port as show in the block diagram below,
- b. Spectrum Setting: RBW=3KHz, VBW=10 KHz, Sweep time = auto.

7.3 TEST SETUP



7.4 EUT OPERATION CONDITIONS

The EUT was programmed to be in continuously transmitting mode.

7.5 TEST RESULTS

Please refer to the APPENDIX F.

8 ANTENNA CONDUCTED SPURIOUS EMISSION

8.1 APPLIED PROCEDURES / LIMIT

In any 100 kHz bandwidth outside the frequency band in which the spread spectrum or digitally modulated device is operating, the RF power that is produced shall be at least 30 dB below that in the 100 kHz bandwidth within the band that contains the highest level of the desired power, based on either an RF conducted or a radiated measurement, provided that the transmitter demonstrates compliance with the peak conducted power limits.

8.2 TEST PROCEDURE

- a. The EUT was directly connected to the spectrum analyzer and antenna output port as show in the block diagram below,
- b. Spectrum Setting : RBW= 100KHz, VBW=300KHz, Sweep time = 10 ms.

8.3 TEST SETUP

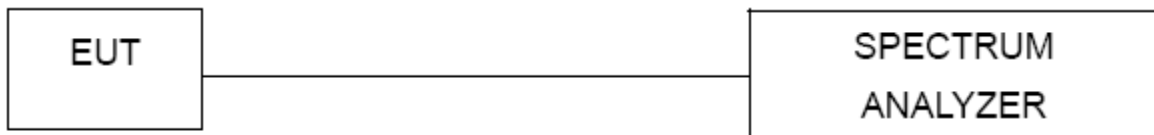

8.4 EUT OPERATION CONDITIONS

The EUT was programmed to be in continuously transmitting mode.

8.5 TEST RESULTS

Please refer to the APPENDIX G.

9 LIST OF MEASURING EQUIPMENTS

AC Power Line Conducted Emissions						
Item	Kind of Equipment	Manufacturer	Type No.	Serial No.	Calibrated Date	Calibrated Until
1	TWO-LINE V-NETWORK	R&S	ENV216	101051	2023/7/21	2024/7/20
2	Test Cable	EMCI	EMCRG58-BM-B M-9000	210501	2022/12/15	2023/12/14
3	MXE EMI Receiver	Agilent	N9038A	MY54130009	2023/06/26	2024/06/25
4	Measurement Software	EZ	EZ EMC (Version NB-03A1-01)	N/A	N/A	N/A

Radiated Emissions						
Item	Kind of Equipment	Manufacturer	Type No.	Serial No.	Calibrated Date	Calibrated Until
1	Preamplifier	EMCI	EMC051845SE	980779	2022/12/19	2023/12/18
2	Preamplifier	EMCI	EMC184045SE	980512	2022/12/02	2023/12/01
3	Preamplifier	EMCI	EMC001340	980555	2022/12/05	2023/12/04
4	Test Cable	EMCI	EMCCFD400-NM -NM-8000	200343	2023/11/14	2024/11/13
5	Test Cable	EMCI	EMC105-SM-SM-3000	210118	2022/12/08	2023/12/07
6	Test Cable	EMCI	EMC105-SM-SM-7000	210117	2023/11/14	2024/11/13
7	Test Cable	EMCI	EMCCFD400-NM -NM-3300	200348	2023/11/14	2024/11/13
8	EXA Signal Analyzer	keysight	N9010A	MY56480554	2023/9/12	2024/9/11
9	Loop Ant	Electro-Metrics	EMCI-LPA600	274	2023/06/28	2024/06/27
10	Horn Antenna	RFSPIN	DRH18-E	BBHA9170340	2023/02/10	2024/02/09
11	Horn Ant	Schwarzbeck	BBHA 9170D	210109A18E	2023/06/29	2024/06/28
12	Log-bicon Antenna	Schwarzbeck	VULB9168	9168-1207	2023/01/13	2024/01/12
13	6dB Attenuator	EMCI	EMCI-N-6-06	AT-N0690	2023/01/13	2024/01/12
14	Measurement Software	EZ	EZ EMC (Version NB-03A1-01)	N/A	N/A	N/A

Bandwidth						
Item	Kind of Equipment	Manufacturer	Type No.	Serial No.	Calibrated Date	Calibrated Until
1	Spectrum Analyzer	R&S	FSP30	100854	2023/06/26	2024/06/25

Output Power						
Item	Kind of Equipment	Manufacturer	Type No.	Serial No.	Calibrated Date	Calibrated Until
1	Spectrum Analyzer	R&S	FSP30	100854	2023/06/26	2024/06/25

Power Spectral Density						
Item	Kind of Equipment	Manufacturer	Type No.	Serial No.	Calibrated Date	Calibrated Until
1	Spectrum Analyzer	R&S	FSP30	100854	2023/06/26	2024/06/25

Antenna conducted Spurious Emission						
Item	Kind of Equipment	Manufacturer	Type No.	Serial No.	Calibrated Date	Calibrated Until
1	Spectrum Analyzer	R&S	FSP30	100854	2023/06/26	2024/06/25

Remark: "N/A" denotes no model name, no serial no. or no calibration specified.
All calibration period of equipment list is one year.

10 EUT TEST PHOTO

Please refer to APPENDIX-TEST PHOTOS.

11 EUT PHOTOS

Please refer to APPENDIX-EUT PHOTOS.

APPENDIX A AC POWER LINE CONDUCTED EMISSIONS

Test Mode	Normal	Tested Date	2023/11/16
Test Frequency	-	Phase	Line

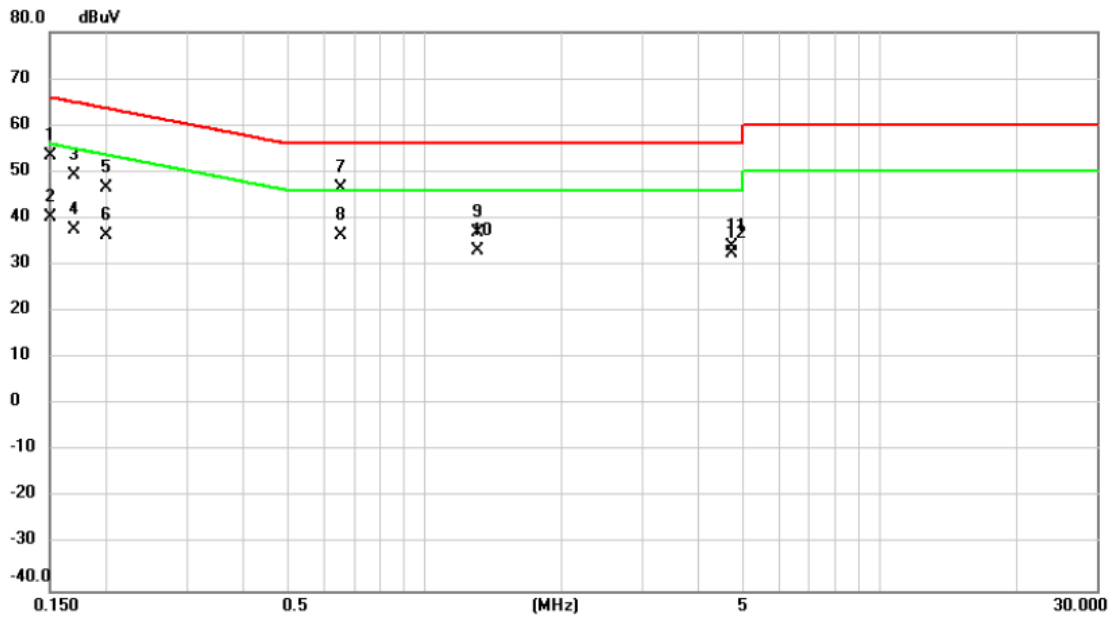

No.	Mk.	Freq. MHz	Reading Level dBuV	Correct Factor dB	Measure- ment dBuV	Limit dBuV	Margin dB	Detector	Comment
1		0.1503	43.65	9.67	53.32	65.98	-12.66	QP	
2		0.1503	30.44	9.67	40.11	55.98	-15.87	AVG	
3		0.1700	39.49	9.67	49.16	64.96	-15.80	QP	
4		0.1700	27.81	9.67	37.48	54.96	-17.48	AVG	
5		0.1997	36.88	9.67	46.55	63.62	-17.07	QP	
6		0.1997	26.53	9.67	36.20	53.62	-17.42	AVG	
7	*	0.6530	36.88	9.70	46.58	56.00	-9.42	QP	
8		0.6530	26.60	9.70	36.30	46.00	-9.70	AVG	
9		1.3055	27.26	9.75	37.01	56.00	-18.99	QP	
10		1.3055	23.33	9.75	33.08	46.00	-12.92	AVG	
11		4.7255	24.14	9.89	34.03	56.00	-21.97	QP	
12		4.7255	22.43	9.89	32.32	46.00	-13.68	AVG	

REMARKS:

- (1) Measurement Value = Reading Level + Correct Factor.
- (2) Margin Level = Measurement Value - Limit Value.

Test Mode	Normal	Tested Date	2023/11/16
Test Frequency	-	Phase	Neutral

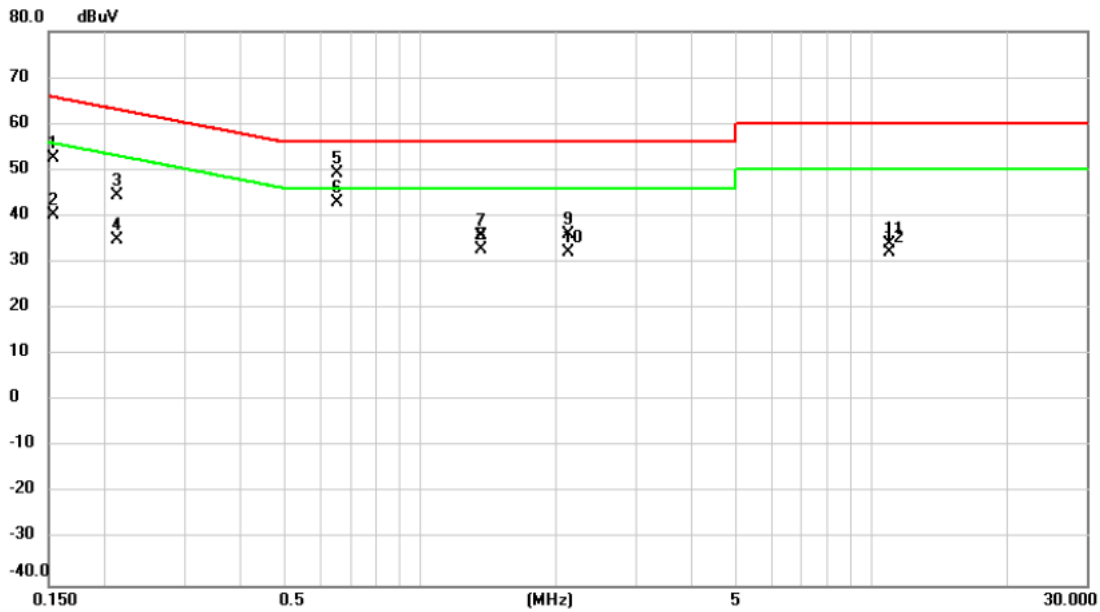

No.	Mk.	Freq. MHz	Reading Level dBuV	Correct Factor dB	Measure- ment dBuV	Limit dBuV	Margin dB	Detector	Comment
1		0.1538	42.91	9.67	52.58	65.79	-13.21	peak	
2		0.1538	30.62	9.67	40.29	65.79	-25.50	peak	
3		0.2123	34.76	9.66	44.42	63.11	-18.69	peak	
4		0.2123	25.11	9.66	34.77	63.11	-28.34	peak	
5	*	0.6530	39.51	9.70	49.21	56.00	-6.79	peak	
6		0.6530	33.20	9.70	42.90	56.00	-13.10	peak	
7		1.3595	26.05	9.75	35.80	56.00	-20.20	peak	
8		1.3595	22.87	9.75	32.62	56.00	-23.38	peak	
9		2.1290	26.17	9.81	35.98	56.00	-20.02	peak	
10		2.1290	22.45	9.81	32.26	56.00	-23.74	peak	
11		10.9250	23.70	10.11	33.81	60.00	-26.19	peak	
12		10.9250	21.96	10.11	32.07	60.00	-27.93	peak	

REMARKS:

- (1) Measurement Value = Reading Level + Correct Factor.
- (2) Margin Level = Measurement Value - Limit Value.

Test Mode	Idle	Tested Date	2023/11/16
Test Frequency	-	Phase	Line

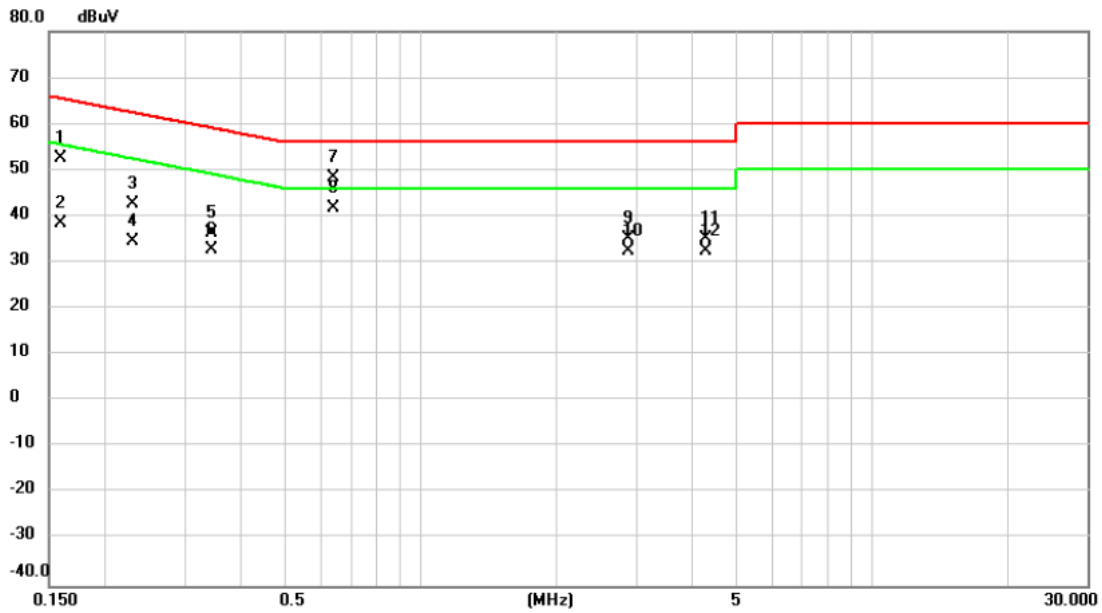

No.	Mk.	Freq. MHz	Reading Level dBuV	Correct Factor dB	Measure- ment dBuV	Limit dBuV	Margin dB	Detector	Comment
1		0.1594	42.79	9.67	52.46	65.50	-13.04	QP	
2		0.1594	28.87	9.67	38.54	55.50	-16.96	AVG	
3		0.2305	33.05	9.67	42.72	62.43	-19.71	QP	
4		0.2305	24.78	9.67	34.45	52.43	-17.98	AVG	
5		0.3438	26.61	9.66	36.27	59.11	-22.84	QP	
6		0.3438	23.04	9.66	32.70	49.11	-16.41	AVG	
7		0.6394	38.51	9.70	48.21	56.00	-7.79	QP	
8	*	0.6394	32.16	9.70	41.86	46.00	-4.14	AVG	
9		2.8850	25.42	9.83	35.25	56.00	-20.75	QP	
10		2.8850	22.67	9.83	32.50	46.00	-13.50	AVG	
11		4.2890	25.42	9.88	35.30	56.00	-20.70	QP	
12		4.2890	22.68	9.88	32.56	46.00	-13.44	AVG	

REMARKS:

- (1) Measurement Value = Reading Level + Correct Factor.
- (2) Margin Level = Measurement Value - Limit Value.

Test Mode	Idle	Tested Date	2023/11/16
Test Frequency	-	Phase	Neutral

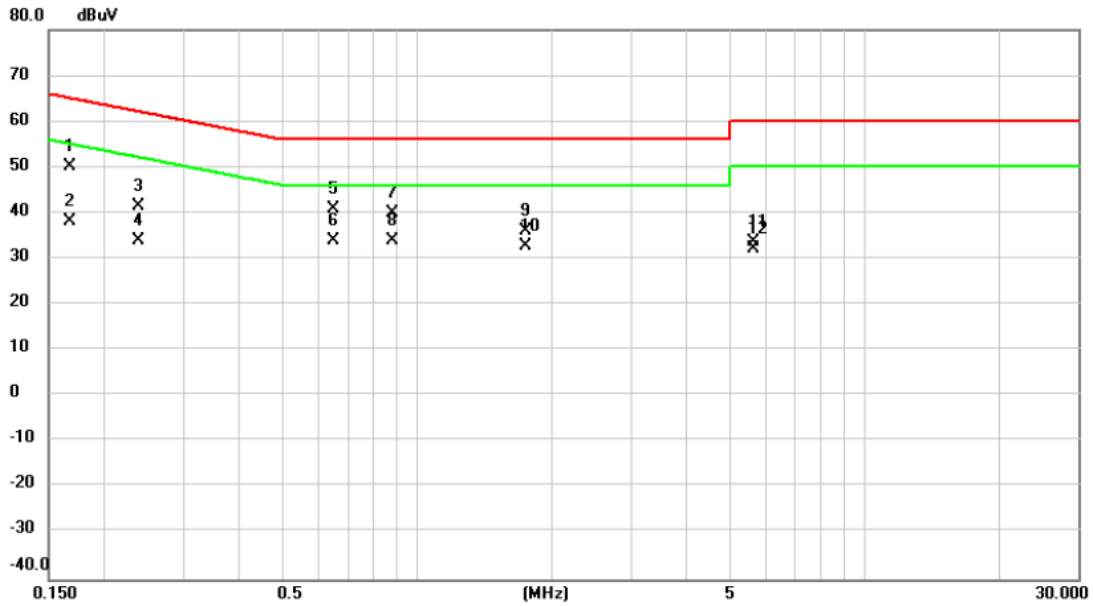

No.	Mk.	Freq. MHz	Reading Level dBuV	Correct Factor dB	Measure- ment dBuV	Limit dBuV	Margin dB	Detector	Comment
1		0.1675	40.60	9.67	50.27	65.08	-14.81	QP	
2		0.1675	28.45	9.67	38.12	55.08	-16.96	AVG	
3		0.2378	31.79	9.66	41.45	62.17	-20.72	QP	
4		0.2378	24.26	9.66	33.92	52.17	-18.25	AVG	
5		0.6485	31.18	9.70	40.88	56.00	-15.12	QP	
6	*	0.6485	24.26	9.70	33.96	46.00	-12.04	AVG	
7		0.8780	30.16	9.72	39.88	56.00	-16.12	QP	
8		0.8780	24.09	9.72	33.81	46.00	-12.19	AVG	
9		1.7510	26.14	9.79	35.93	56.00	-20.07	QP	
10		1.7510	22.99	9.79	32.78	46.00	-13.22	AVG	
11		5.6250	23.72	9.93	33.65	60.00	-26.35	QP	
12		5.6250	22.21	9.93	32.14	50.00	-17.86	AVG	

REMARKS:

- (1) Measurement Value = Reading Level + Correct Factor.
- (2) Margin Level = Measurement Value - Limit Value.

APPENDIX B RADIATED EMISSIONS - 30 MHZ TO 1 GHZ

Test Mode	BLE (1 Mbps)	Test Date	2023/11/15
Test Frequency	2440MHz	Polarization	Vertical
Temp	25°C	Hum.	60%

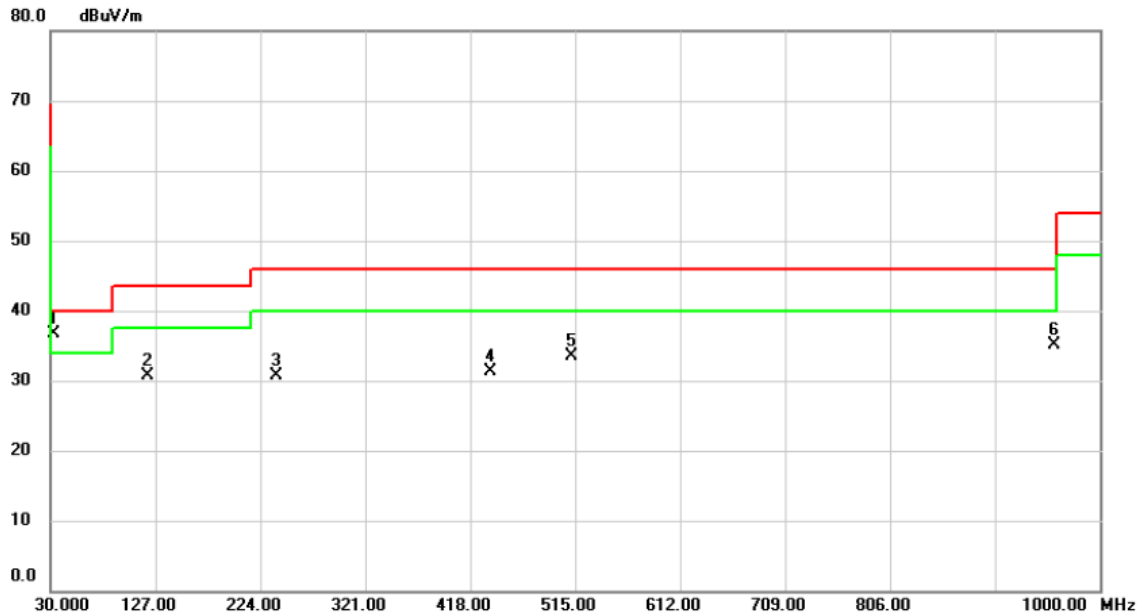

No.	Mk.	Freq.	Reading Level	Correct Factor	Measurement	Limit	Margin	Antenna Height	Table Degree	
		MHz	dBuV	dB	dBuV/m	dBuV/m	dB	cm	degree	Comment
1	*	32.9100	50.21	-13.42	36.79	40.00	-3.21	100	84	
2		120.2100	44.78	-14.02	30.76	43.50	-12.74	100	93	
3		238.5500	43.13	-12.50	30.63	46.00	-15.37	100	45	
4		436.4300	37.96	-6.63	31.33	46.00	-14.67	100	102	
5		512.0900	38.55	-5.09	33.46	46.00	-12.54	100	162	
6		957.3200	32.87	2.30	35.17	46.00	-10.83	100	166	

REMARKS:

- (1) Measurement Value = Reading Level + Correct Factor.
- (2) Margin Level = Measurement Value - Limit Value.

Test Mode	BLE (1 Mbps)	Test Date	2023/11/15
Test Frequency	2440MHz	Polarization	Horizontal
Temp	24°C	Hum.	46%

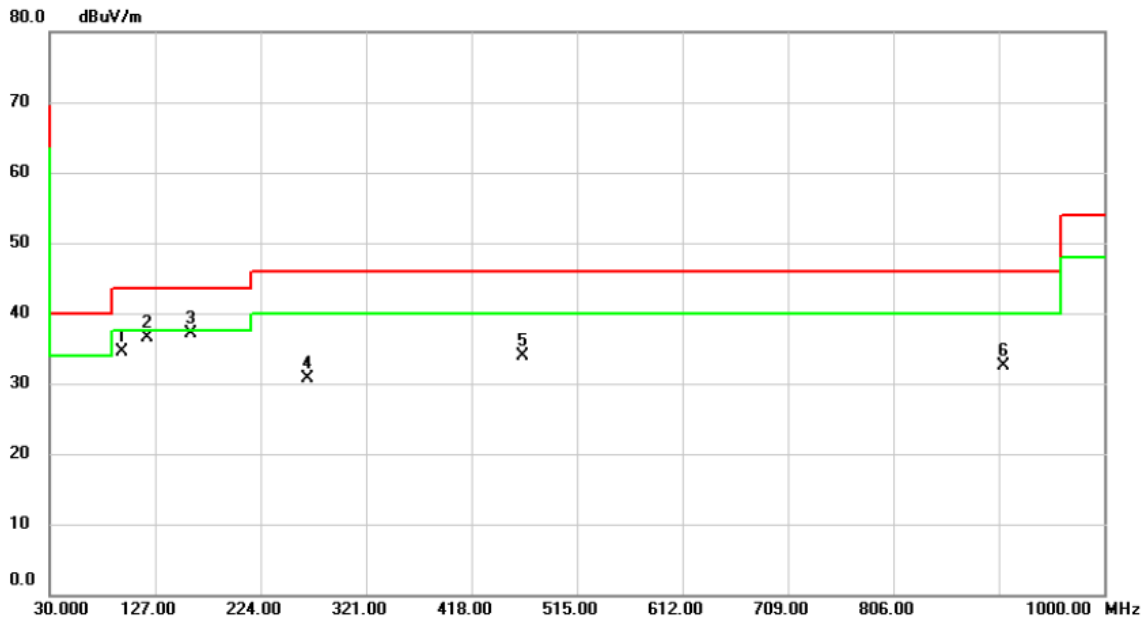

No.	Mk.	Freq. MHz	Reading Level dBuV	Correct Factor dB	Measure- ment dBuV/m	Limit dBuV/m	Margin dB	Detector	Antenna Height cm	Table Degree	Comment
1		95.9600	51.07	-16.60	34.47	43.50	-9.03	peak	200	46	
2		120.2100	50.59	-14.02	36.57	43.50	-6.93	peak	200	19	
3	*	159.9800	48.33	-11.30	37.03	43.50	-6.47	peak	200	193	
4		266.6800	42.18	-11.39	30.79	46.00	-15.21	peak	100	83	
5		464.5600	39.95	-5.97	33.98	46.00	-12.02	peak	100	270	
6		906.8800	30.87	1.54	32.41	46.00	-13.59	peak	100	252	

REMARKS:

- (1) Measurement Value = Reading Level + Correct Factor.
- (2) Margin Level = Measurement Value - Limit Value.

APPENDIX C ADIATED EMISSIONS - ABOVE 1 GHZ

Test Mode	BLE (1 Mbps)	Test Date	2023/11/15
Test Frequency	2402MHz	Polarization	Horizontal
Temp	25°C	Hum.	60%

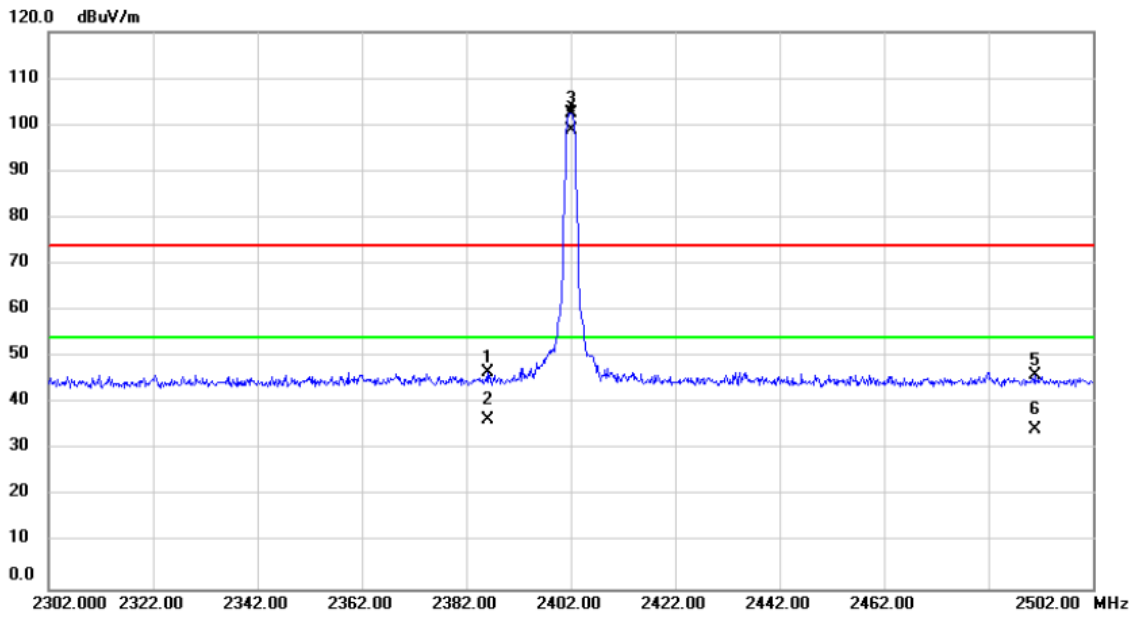

No.	Mk.	Freq. MHz	Reading Level dBuV	Correct Factor dB	Measure- ment dBuV/m	Limit dBuV/m	Margin dB	Antenna Height cm	Table Degree	Comment
1		2386.000	42.52	4.10	46.62	74.00	-27.38			peak
2		2386.000	32.46	4.10	36.56	54.00	-17.44			AVG
3	X	2402.000	98.39	4.11	102.50	74.00	28.50			No Limit
4	*	2402.000	94.72	4.11	98.83	54.00	44.83			No Limit
5		2490.800	41.78	4.20	45.98	74.00	-28.02			peak
6		2490.800	30.02	4.20	34.22	54.00	-19.78			AVG

REMARKS:

- (1) Measurement Value = Reading Level + Correct Factor.
- (2) Margin Level = Measurement Value - Limit Value.

Test Mode	BLE (1 Mbps)	Test Date	2023/11/15
Test Frequency	2480MHz	Polarization	Horizontal
Temp	25°C	Hum.	60%

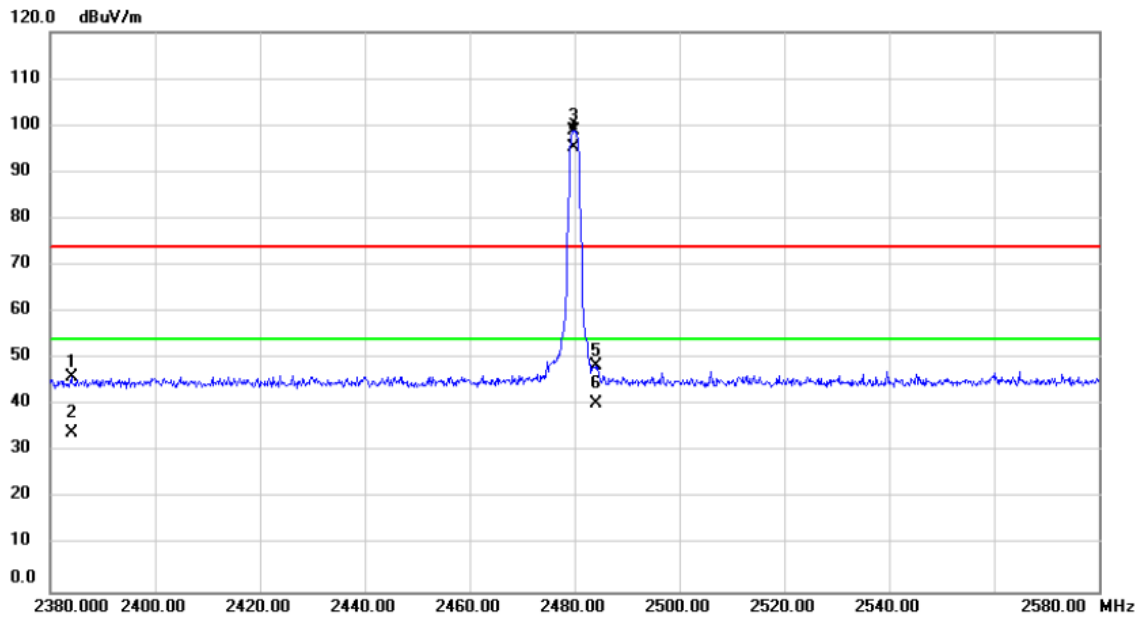

No.	Mk.	Freq.	Reading Level	Correct Factor	Measurement	Limit	Margin	Antenna Height	Table Degree	
		MHz	dBuV	dB	dBuV/m	dBuV/m	dB	cm	degree	Comment
1		2384.000	41.83	4.10	45.93	74.00	-28.07			peak
2		2384.000	30.01	4.10	34.11	54.00	-19.89			AVG
3	X	2479.800	94.62	4.20	98.82	74.00	24.82			No Limit
4	*	2479.800	90.94	4.20	95.14	54.00	41.14			No Limit
5		2484.200	44.33	4.21	48.54	74.00	-25.46			peak
6		2484.200	36.24	4.21	40.45	54.00	-13.55			AVG

REMARKS:

- (1) Measurement Value = Reading Level + Correct Factor.
- (2) Margin Level = Measurement Value - Limit Value.

Test Mode	BLE (1 Mbps)	Test Date	2023/11/15
Test Frequency	2402MHz	Polarization	Vertical
Temp	25°C	Hum.	60%

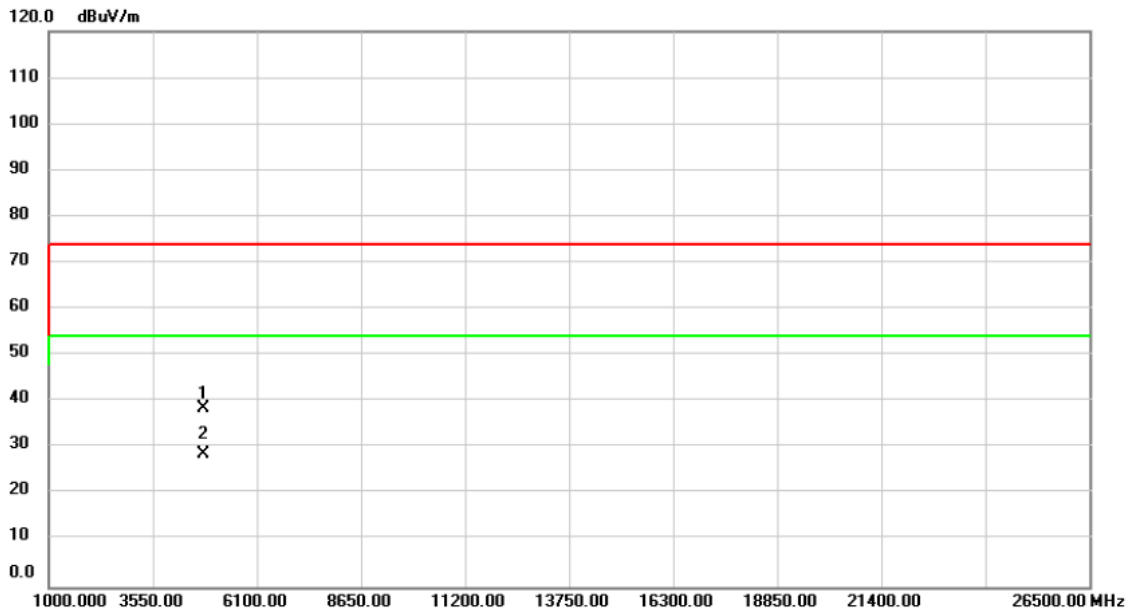

No.	Mk.	Freq. MHz	Reading Level dBuV	Correct Factor dB	Measure- ment dBuV/m	Limit dBuV/m	Margin dB	Detector	Antenna Height cm	Table Degree	Comment
1		4804.000	37.74	0.70	38.44	74.00	-35.56	peak			
2	*	4804.000	27.98	0.70	28.68	54.00	-25.32	AVG			

REMARKS:

- (1) Measurement Value = Reading Level + Correct Factor.
- (2) Margin Level = Measurement Value - Limit Value.

Test Mode	BLE (1 Mbps)	Test Date	2023/11/15
Test Frequency	2402MHz	Polarization	Horizontal
Temp	25°C	Hum.	60%

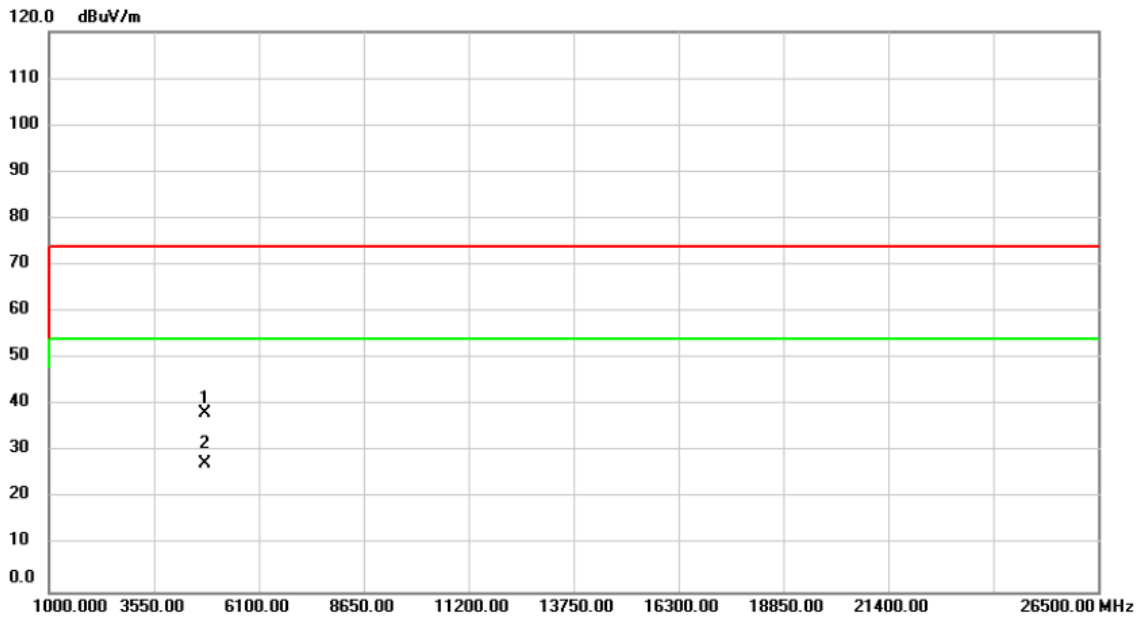

No.	Mk.	Freq.	Reading Level	Correct Factor	Measurement	Limit	Margin	Antenna Height	Table Degree	
		MHz	dBuV	dB	dBuV/m	dBuV/m	dB	cm	degree	Comment
1		4804.000	37.61	0.70	38.31	74.00	-35.69			peak
2	*	4804.000	26.67	0.70	27.37	54.00	-26.63			AVG

REMARKS:

- (1) Measurement Value = Reading Level + Correct Factor.
- (2) Margin Level = Measurement Value - Limit Value.

Test Mode	BLE (1 Mbps)	Test Date	2023/11/15
Test Frequency	2440MHz	Polarization	Vertical
Temp	25°C	Hum.	60%

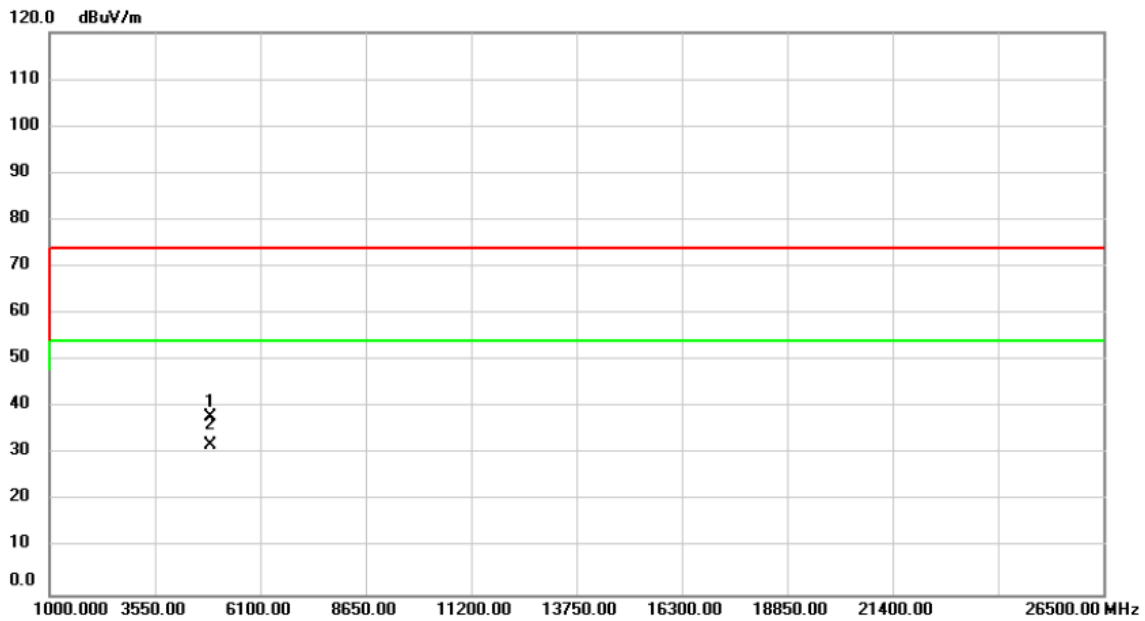

No.	Mk.	Freq.	Reading Level	Correct Factor	Measurement	Limit	Margin	Antenna Height	Table Degree	Comment
		MHz	dBuV	dB	dBuV/m	dBuV/m	dB	cm	degree	
1		4880.000	37.08	0.92	38.00	74.00	-36.00			peak
2	*	4880.000	31.10	0.92	32.02	54.00	-21.98			AVG

REMARKS:

- (1) Measurement Value = Reading Level + Correct Factor.
- (2) Margin Level = Measurement Value - Limit Value.

Test Mode	BLE (1 Mbps)	Test Date	2023/11/15
Test Frequency	2440MHz	Polarization	Horizontal
Temp	25°C	Hum.	60%

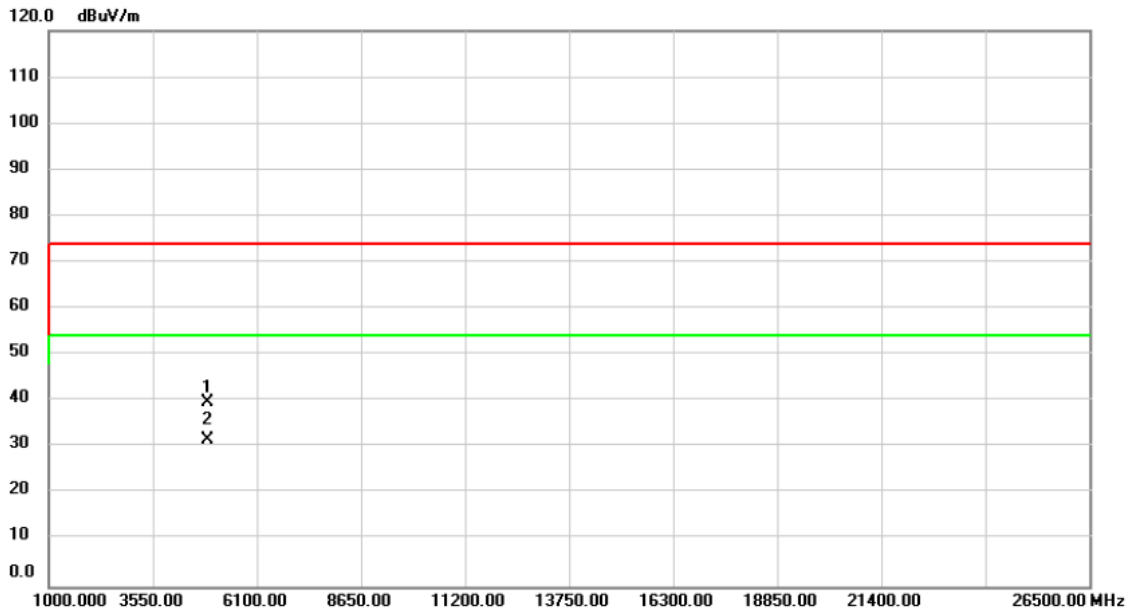

No.	Mk.	Freq.	Reading Level	Correct Factor	Measurement	Limit	Margin	Antenna Height	Table Degree	Comment
		MHz	dBuV	dB	dBuV/m	dBuV/m	dB	cm	degree	
1		4880.000	38.70	0.92	39.62	74.00	-34.38	peak		
2	*	4880.000	30.70	0.92	31.62	54.00	-22.38	AVG		

REMARKS:

- (1) Measurement Value = Reading Level + Correct Factor.
- (2) Margin Level = Measurement Value - Limit Value.

Test Mode	BLE (1 Mbps)	Test Date	2023/11/15
Test Frequency	2480MHz	Polarization	Vertical
Temp	25°C	Hum.	60%

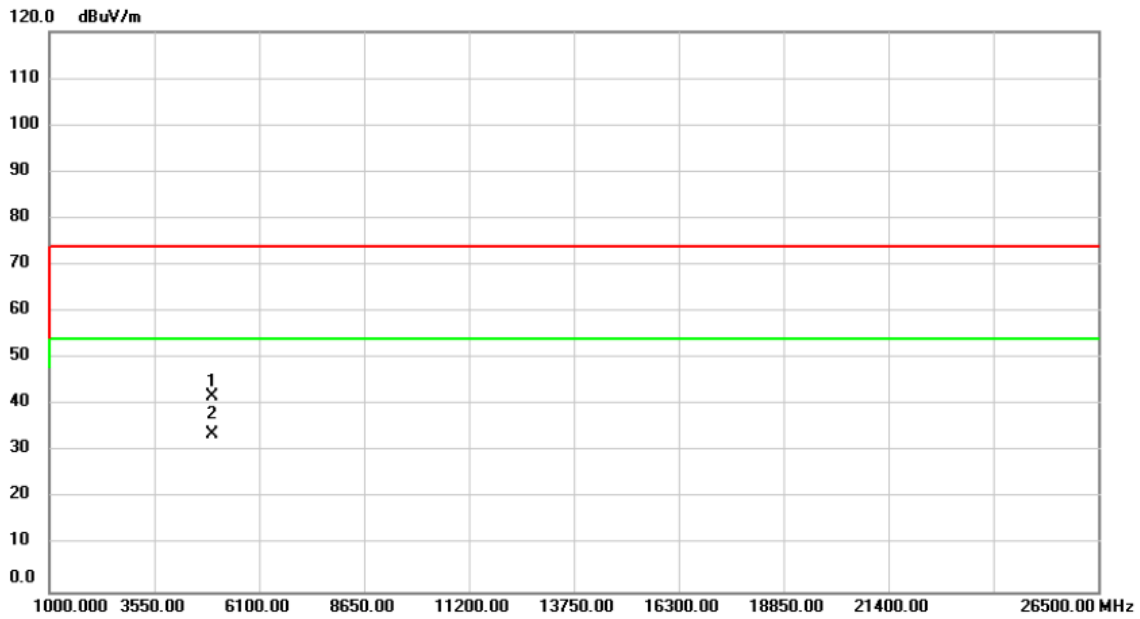

No.	Mk.	Freq. MHz	Reading Level dBuV	Correct Factor dB	Measure- ment dBuV/m	Limit dBuV/m	Margin dB	Antenna Height cm	Table Degree degree	Comment
1		4960.000	40.75	1.15	41.90	74.00	-32.10			peak
2	*	4960.000	32.47	1.15	33.62	54.00	-20.38			AVG

REMARKS:

- (1) Measurement Value = Reading Level + Correct Factor.
- (2) Margin Level = Measurement Value - Limit Value.

Test Mode	BLE (1 Mbps)	Test Date	2023/11/15
Test Frequency	2480MHz	Polarization	Horizontal
Temp	25°C	Hum.	60%

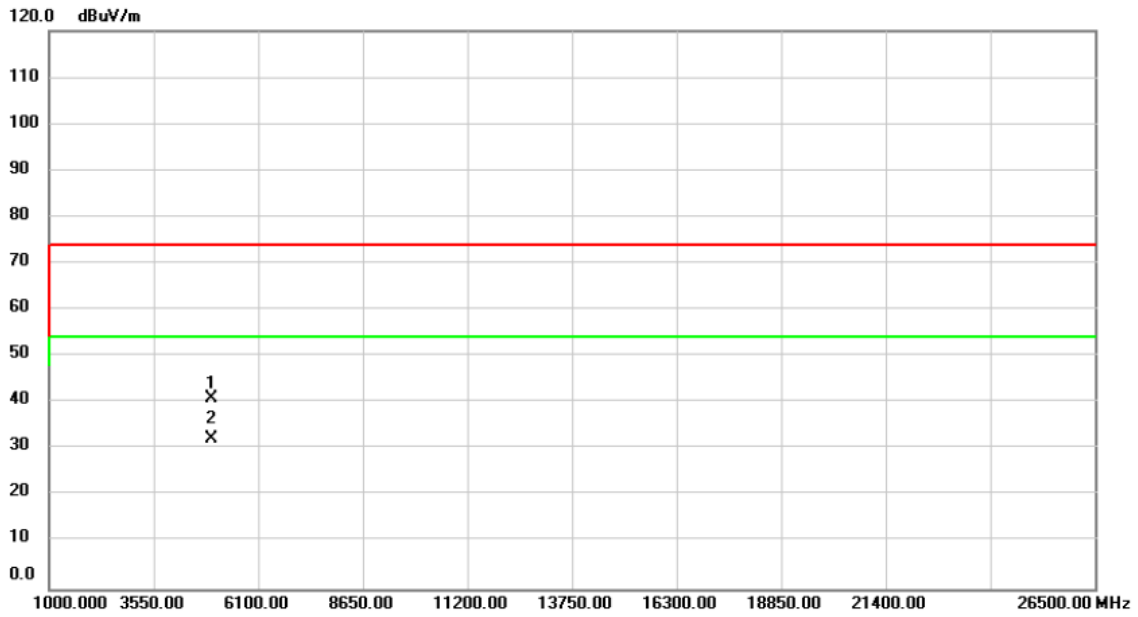

No.	Mk.	Freq.	Reading Level	Correct Factor	Measurement	Limit	Margin	Antenna Height	Table Degree	
		MHz	dBuV	dB	dBuV/m	dBuV/m	dB	cm	degree	Comment
1		4960.000	39.81	1.15	40.96	74.00	-33.04			peak
2	*	4960.000	31.19	1.15	32.34	54.00	-21.66			AVG

REMARKS:

- (1) Measurement Value = Reading Level + Correct Factor.
- (2) Margin Level = Measurement Value - Limit Value.

APPENDIX D BANDWIDTH

Test Mode: 1Mbps

Frequency (MHz)	6dB Bandwidth (MHz)	99% Occupied BW (MHz)	Min. Limit (kHz)	Test Result
2402	0.658	1.036	500	Pass
2440	0.659	1.036	500	Pass
2480	0.648	1.028	500	Pass

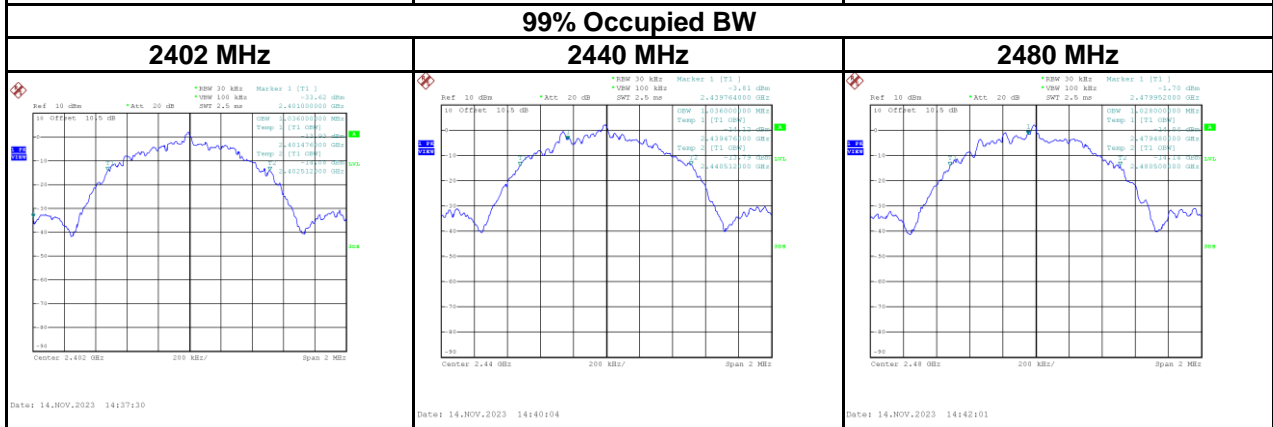
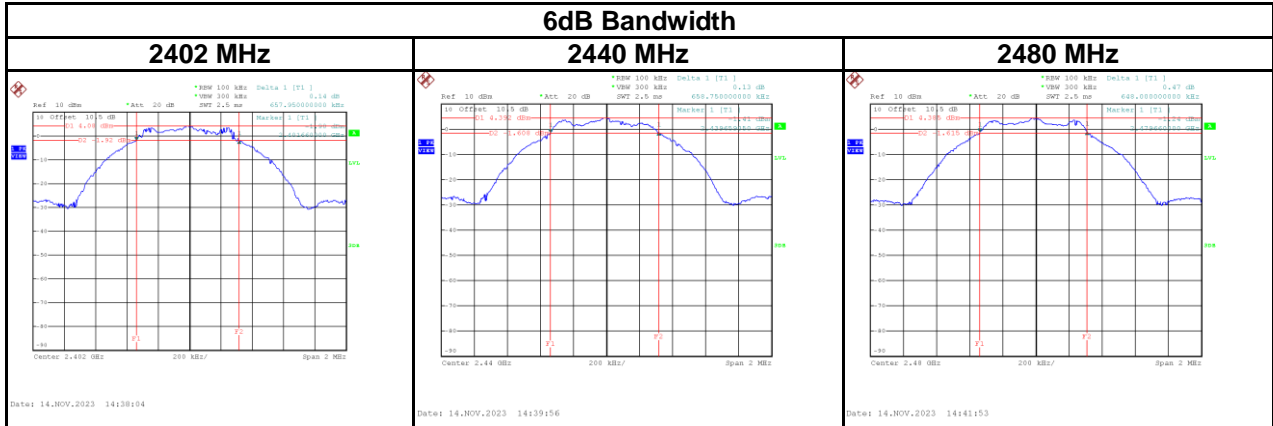

APPENDIX E OUTPUT POWER

Test Mode :	1Mbps	Tested Date	2024/1/6
-------------	-------	-------------	----------

Frequency (MHz)	Conducted Power (dBm)	Conducted Power (W)	Max. Limit (dBm)	Max. Limit (W)	Test Result
2402	7.05	0.0051	30.00	1.0000	Pass
2440	7.50	0.0056	30.00	1.0000	Pass
2480	7.21	0.0053	30.00	1.0000	Pass

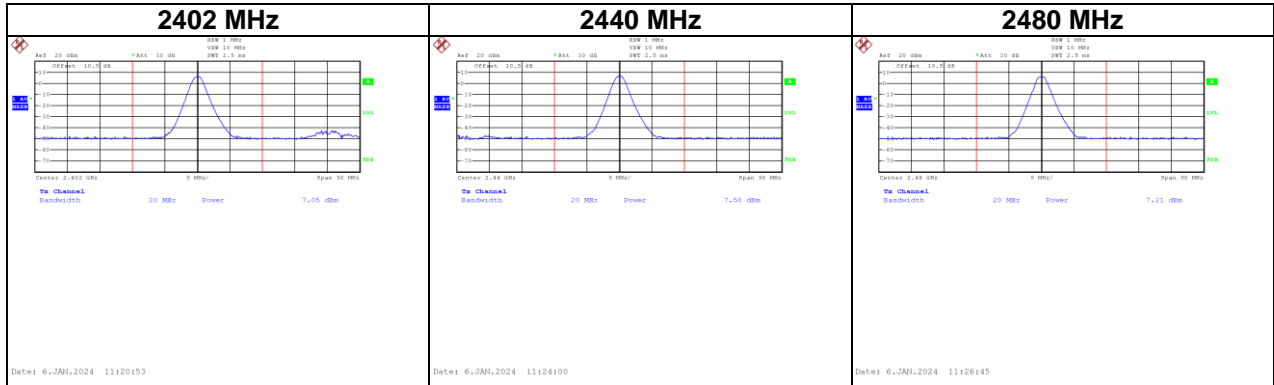

APPENDIX F POWER SPECTRAL DENSITY TEST

Test Mode : 1Mbps

Frequency (MHz)	Power Density (dBm/3kHz)	Max. Limit (dBm/3kHz)	Test Result
2402	-12.27	8	Pass
2440	-10.41	8	Pass
2480	-12.29	8	Pass

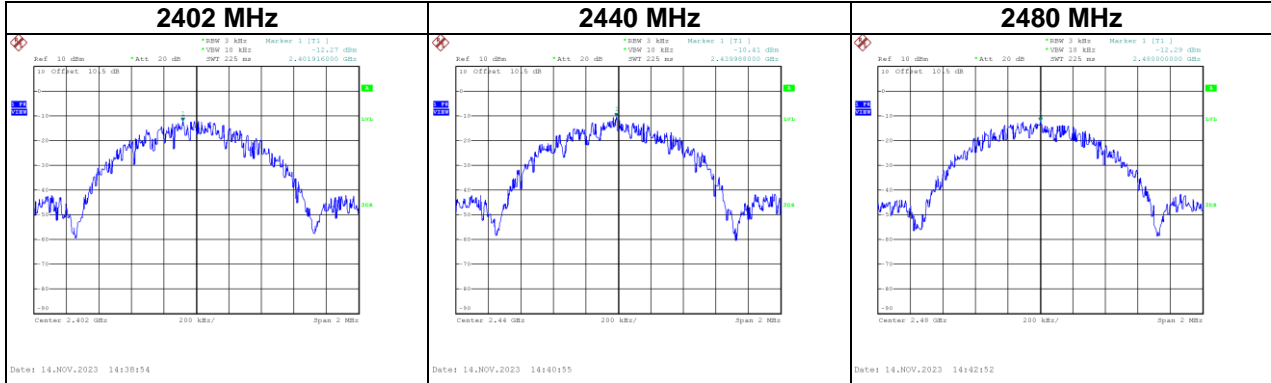

APPENDIX G ANTENNA CONDUCTED SPURIOUS EMISSION

Test Mode : 1Mbps

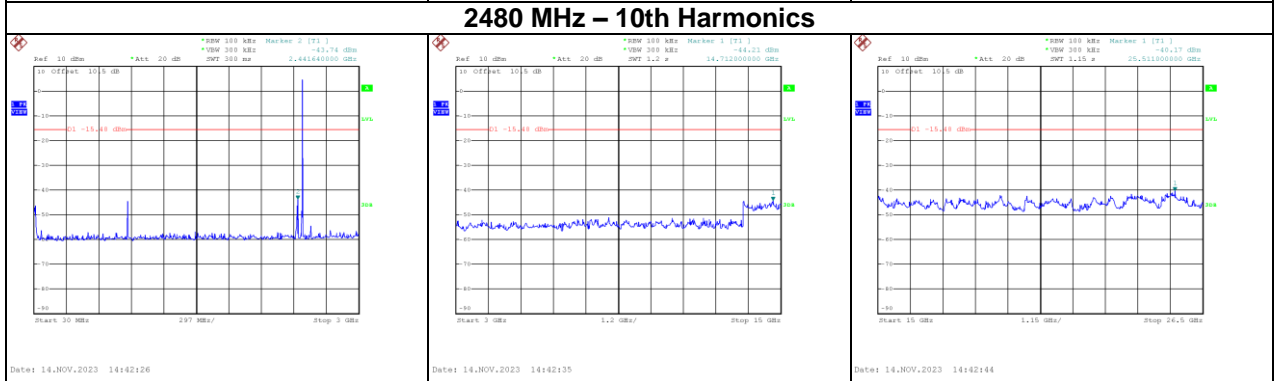
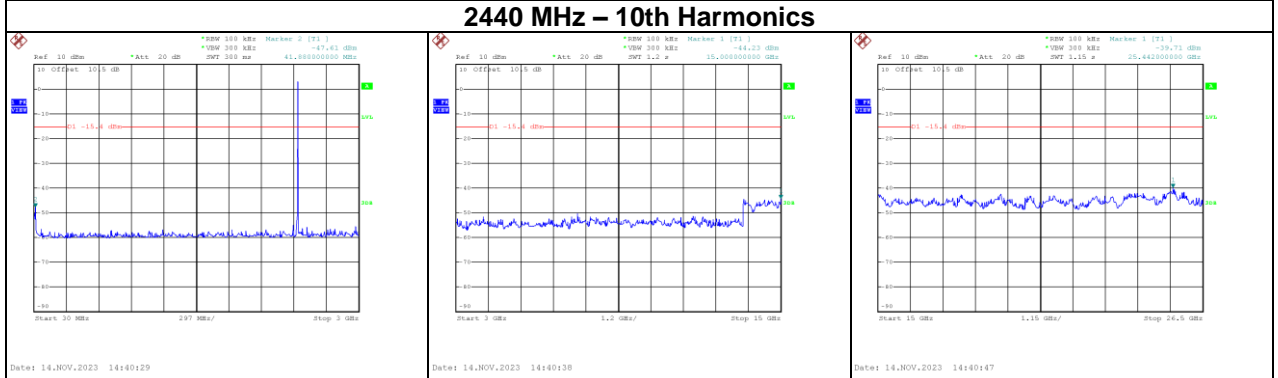
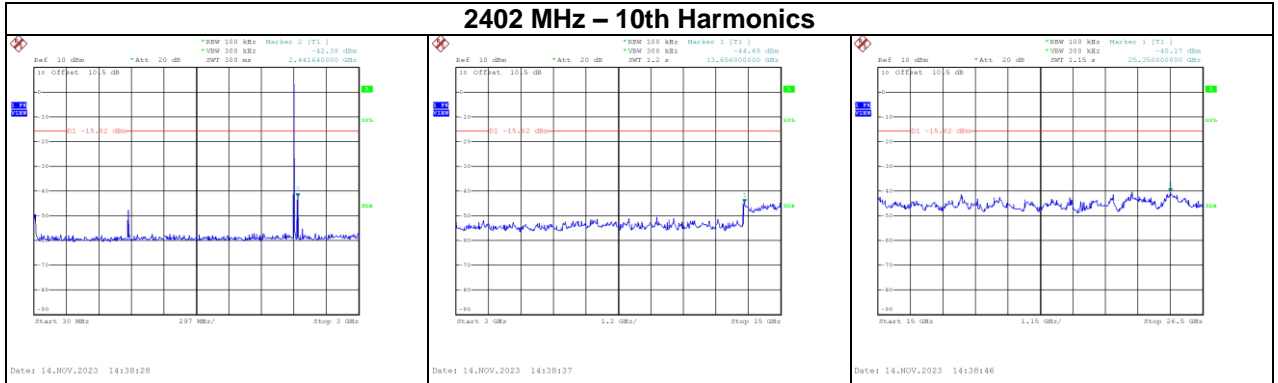
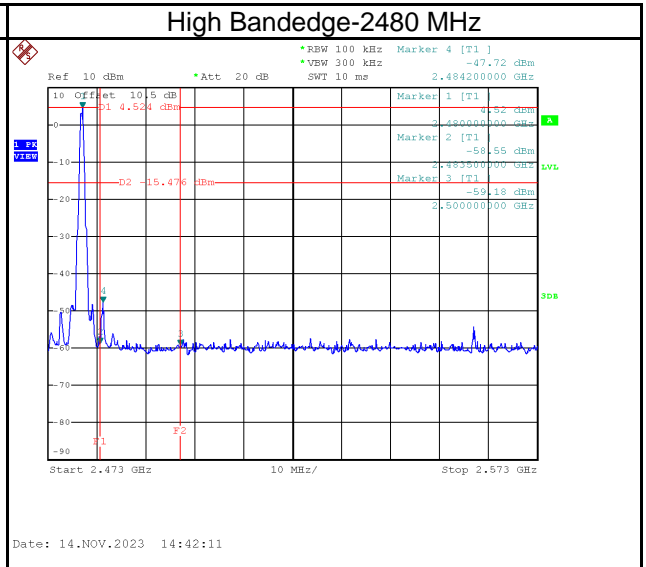
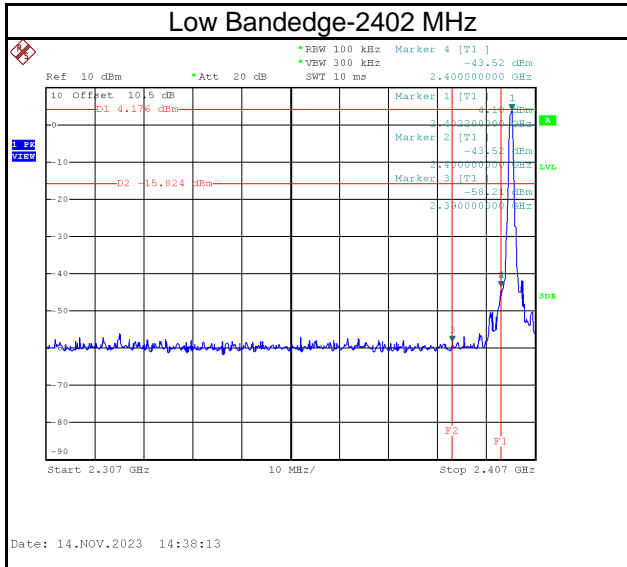

End of Test Report