

802.11ax-HE160 - Ant 1 (Nss = 2)

Channel 15 (6025MHz)

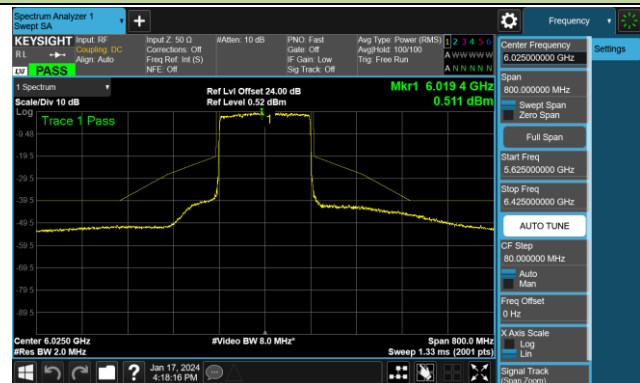

Channel 47 (6185MHz)

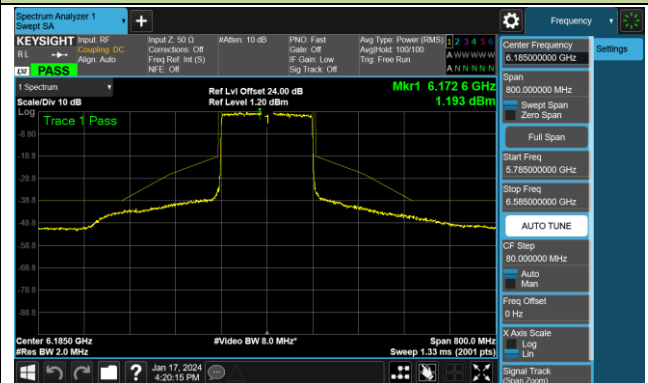

Channel 79 (6345MHz)

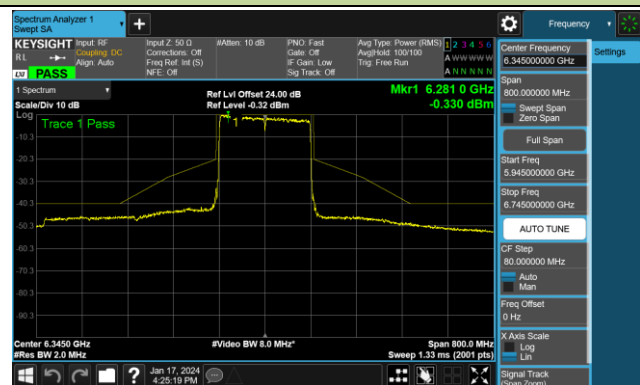

Channel 111 (6505MHz)

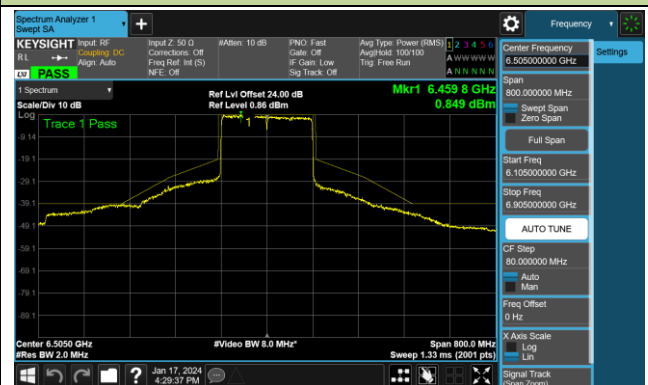

Channel 143 (6665MHz)

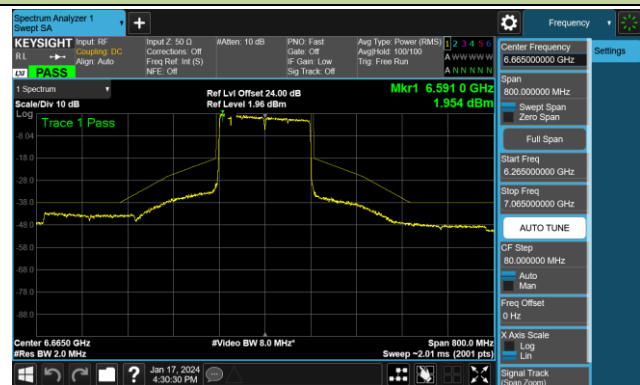

Channel 175 (6825MHz)

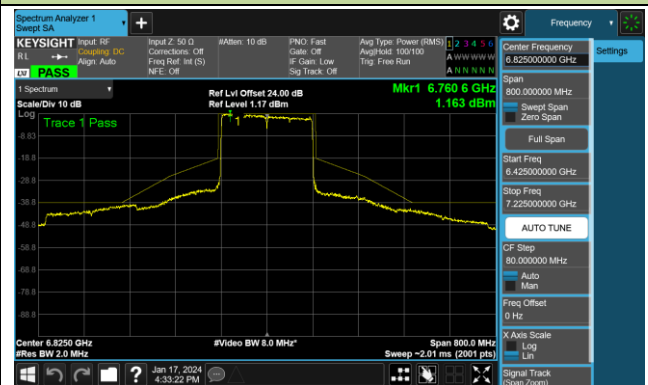

Channel 207 (6985MHz)

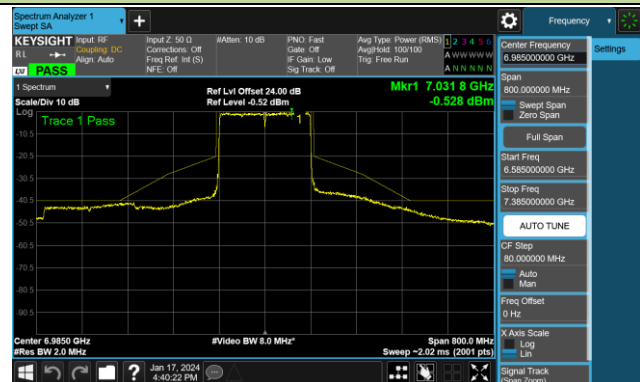

802.11be-EHT20 - Ant 1 (Nss = 2)

Channel 01 (5955MHz)

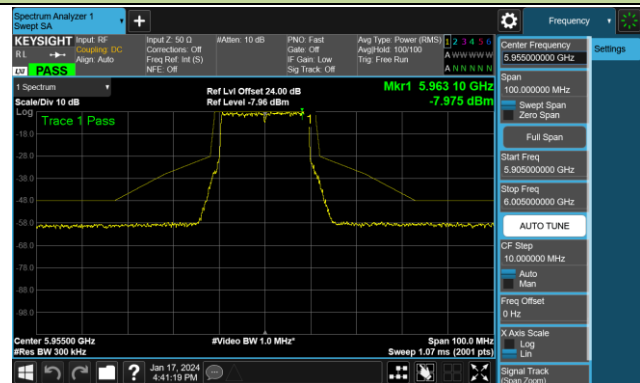

Channel 45 (6175MHz)

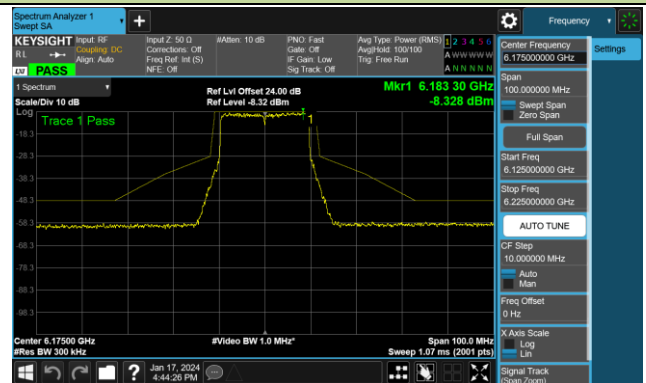

Channel 93 (6415MHz)

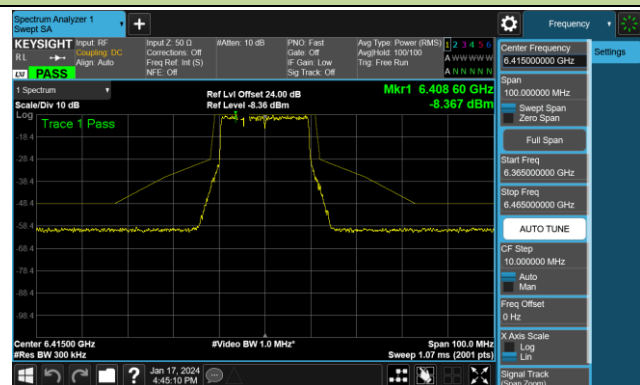

Channel 97 (6435MHz)

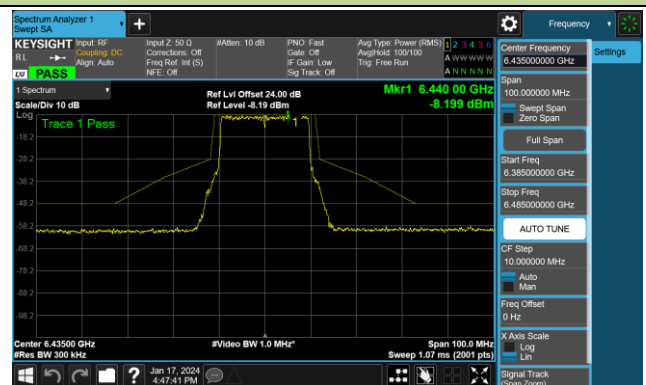

Channel 105 (6475MHz)

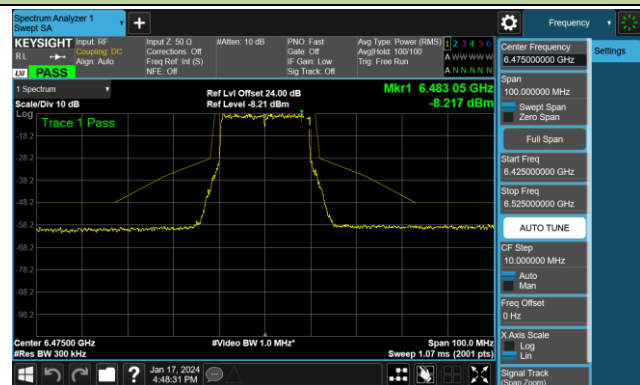

Channel 113 (6515MHz)

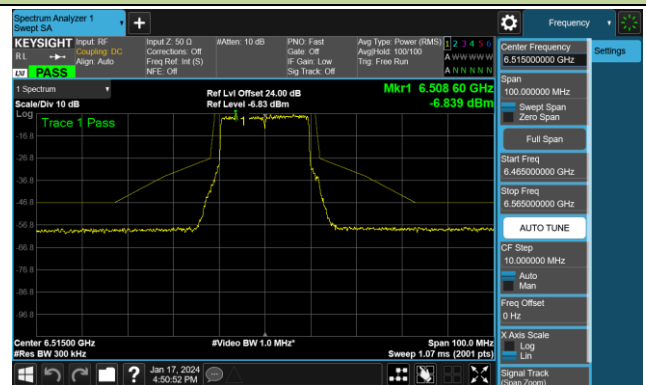

802.11be-EHT20 - Ant 1 (Nss = 1)

Channel 117 (6535MHz)

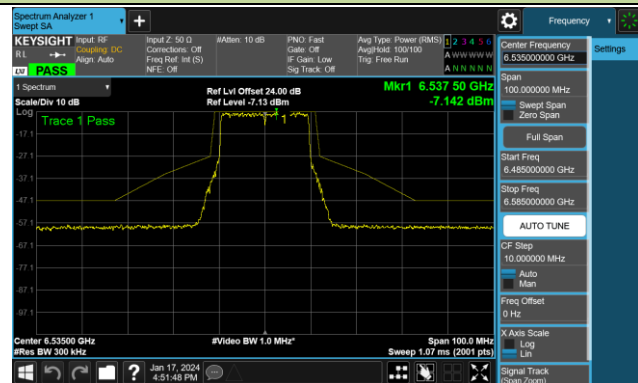

Channel 149 (6695MHz)

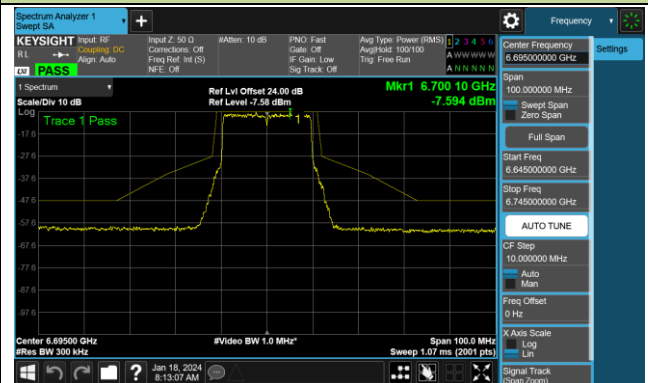

Channel 181 (6855MHz)

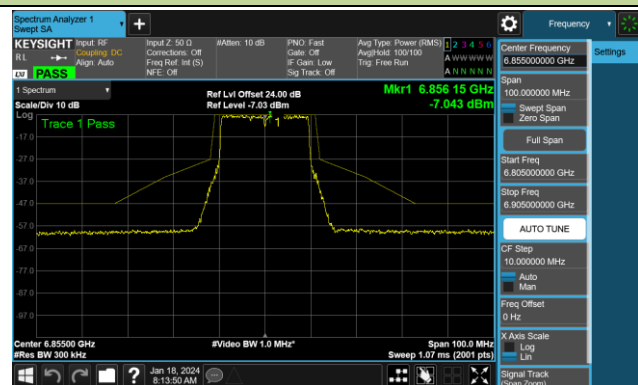

Channel 185 (6875MHz)

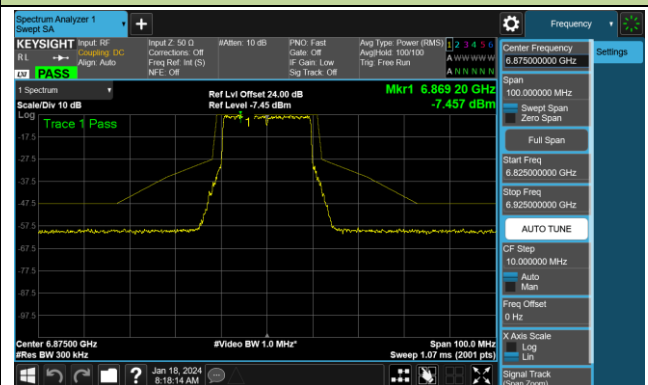

Channel 189 (6895MHz)

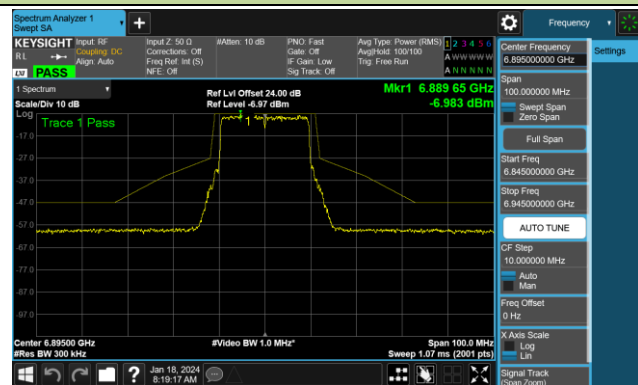

Channel 213 (7015MHz)

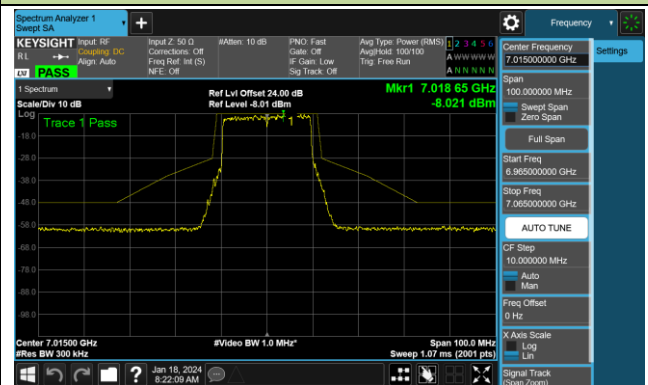

Channel 229 (7095MHz)

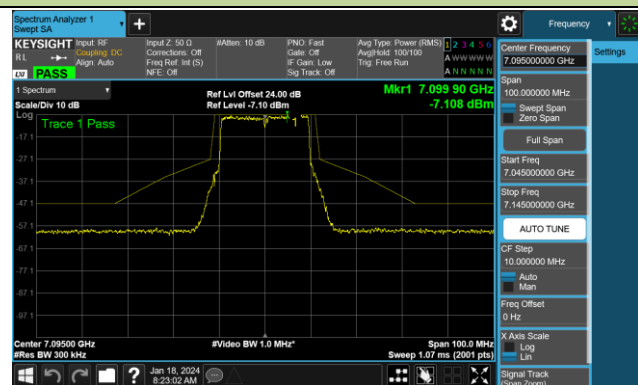

802.11be-EHT40 - Ant 1 (Nss = 2)

Channel 03 (5965MHz)

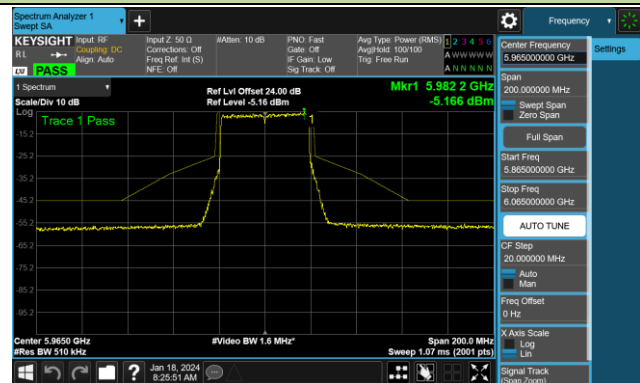

Channel 43 (6165MHz)

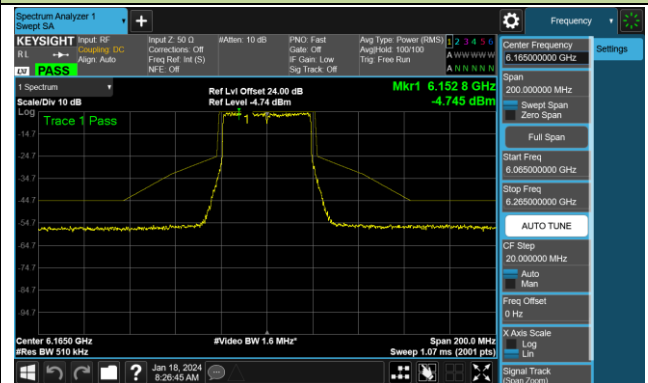

Channel 91 (6405MHz)

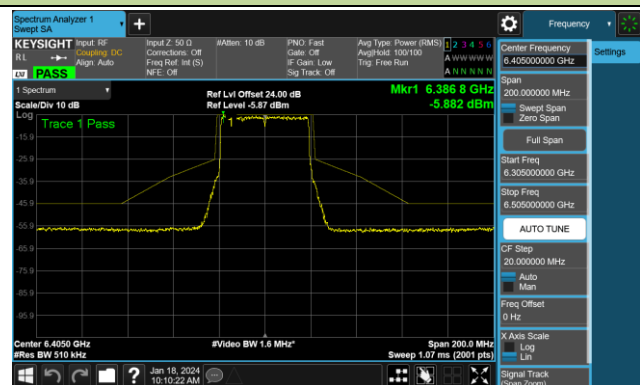

Channel 99 (6445MHz)

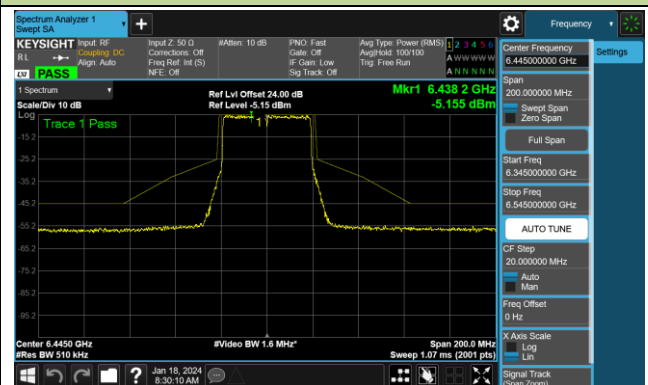

Channel 107 (6485MHz)

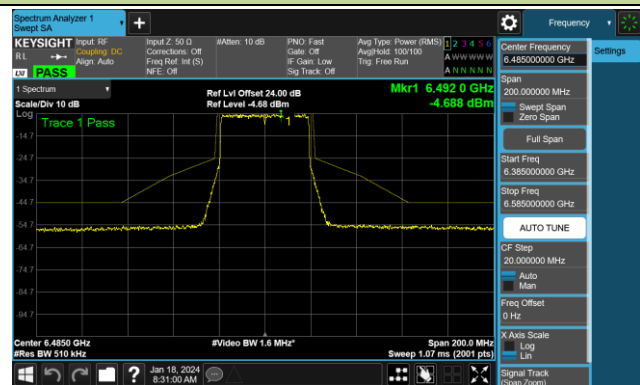

Channel 115 (6525MHz)

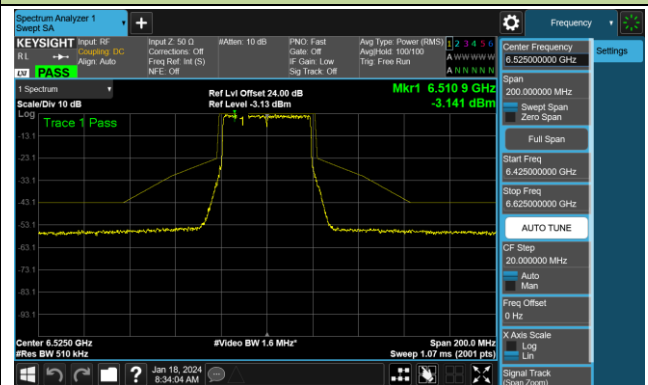

Channel 123 (6565MHz)

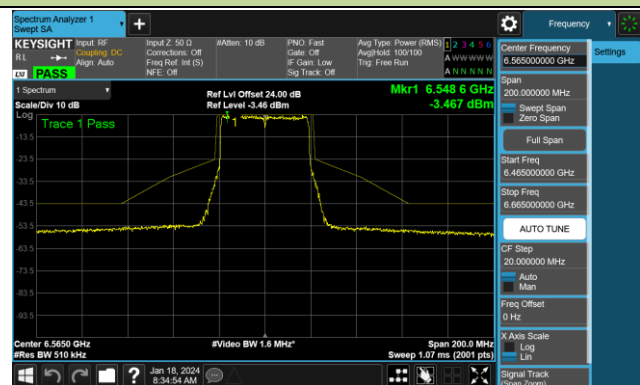

Channel 147 (6685MHz)

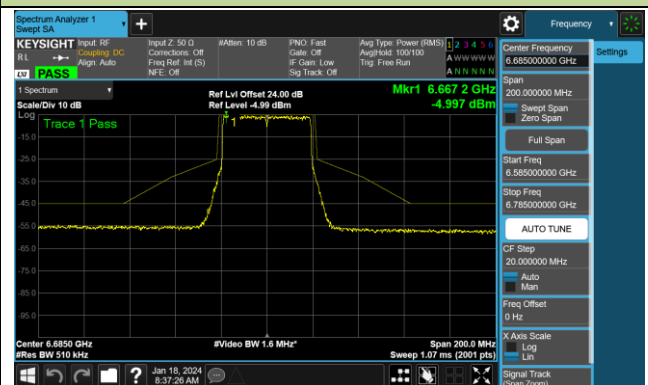

802.11be-EHT40 - Ant 1 (Nss = 2)

Channel 179 (6845MHz)

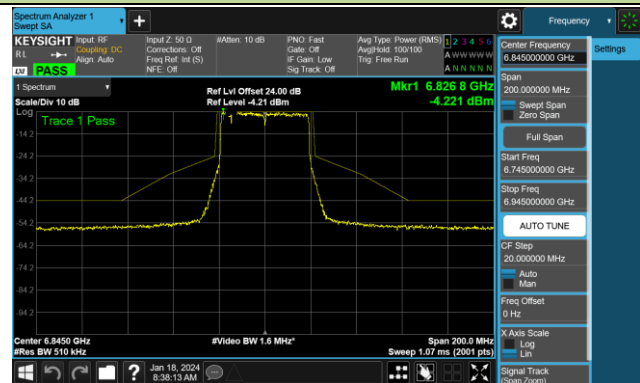

Channel 187 (6885MHz)

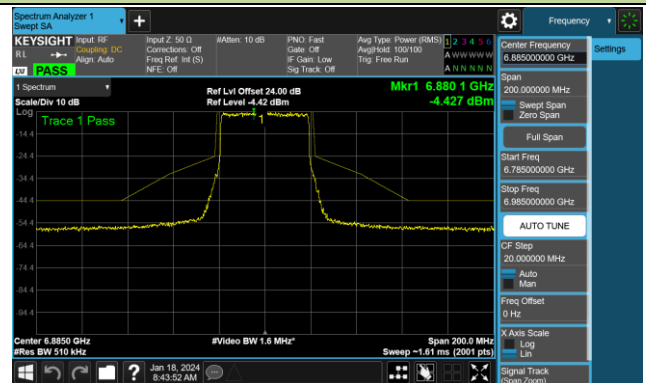

Channel 195 (6925MHz)

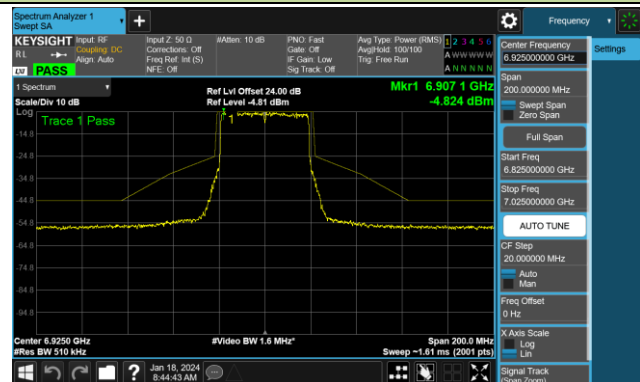

Channel 211 (7005MHz)

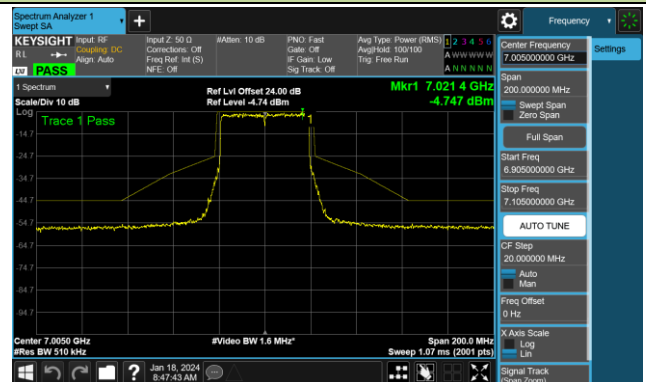

Channel 227 (7085MHz)

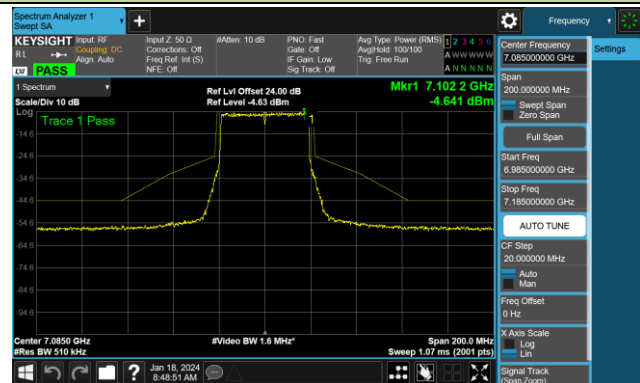

802.11be-EHT80 - Ant 1 (Nss = 2)

Channel 07 (5985MHz)

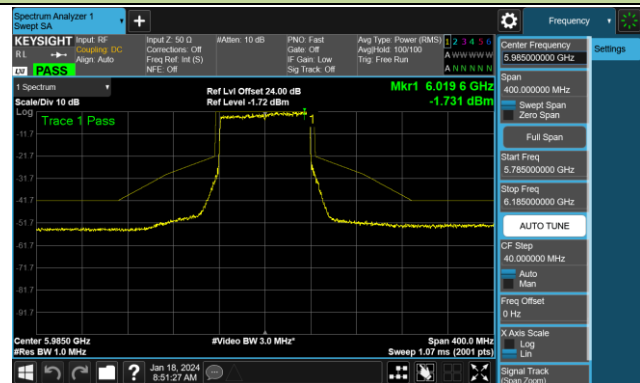

Channel 39 (6145MHz)

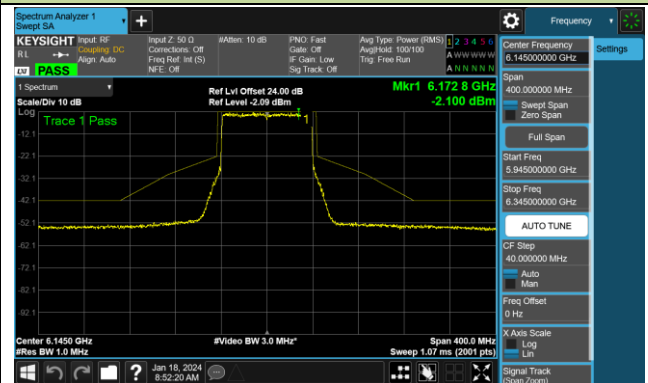

Channel 87 (6385MHz)

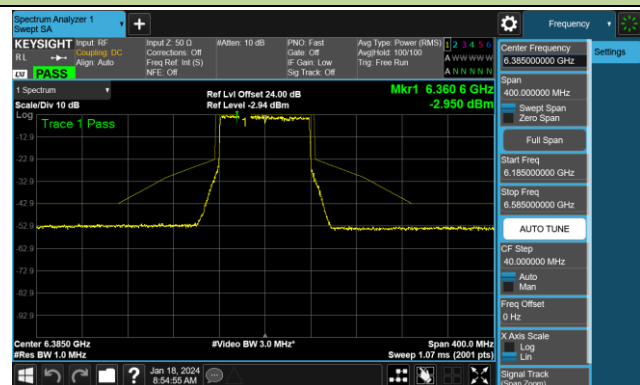

Channel 103 (6465MHz)

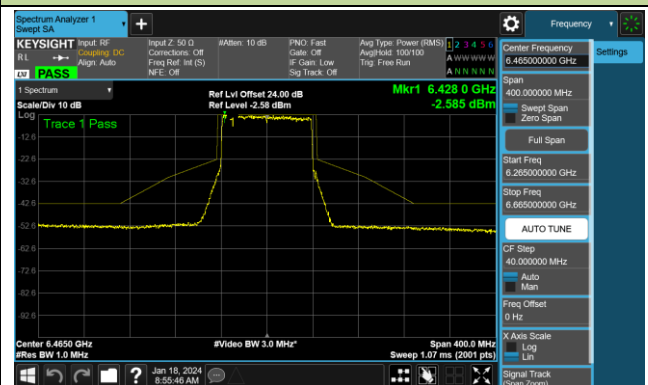

Channel 119 (6545MHz)

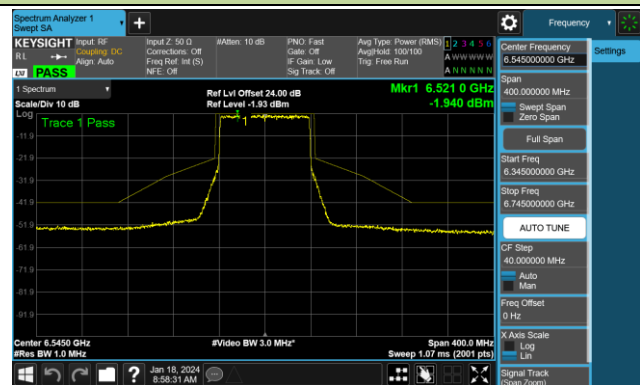

Channel 135 (6625MHz)

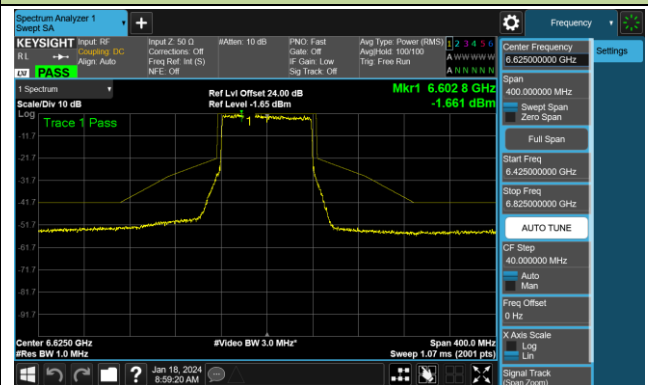

Channel 151 (6705MHz)

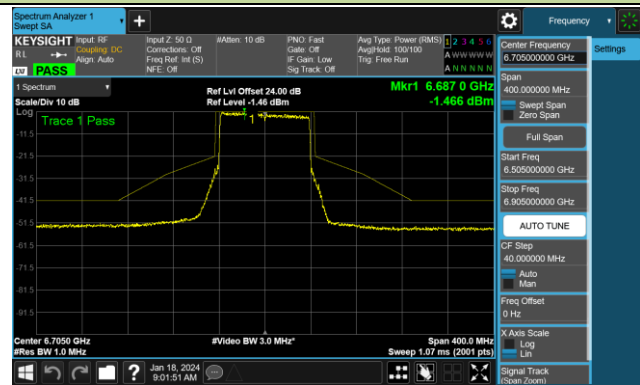

Channel 167 (6785MHz)

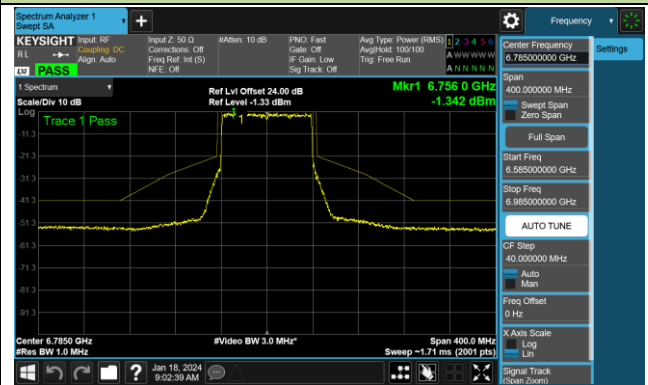

802.11be-EHT80 - Ant 1 (Nss = 2)

Channel 183 (6865MHz)

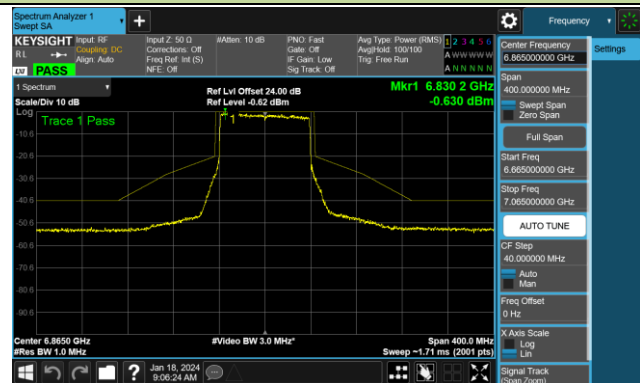

Channel 199 (6945MHz)

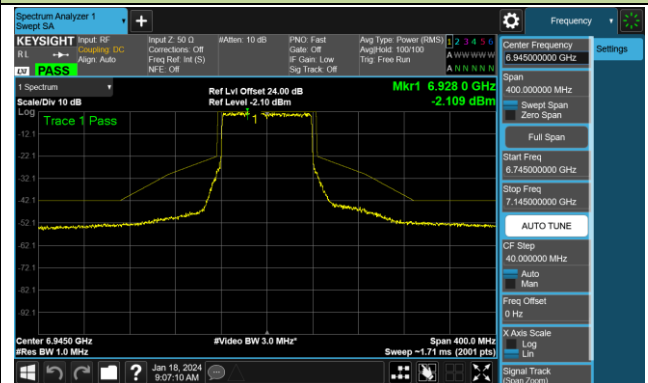

Channel 215 (7025MHz)

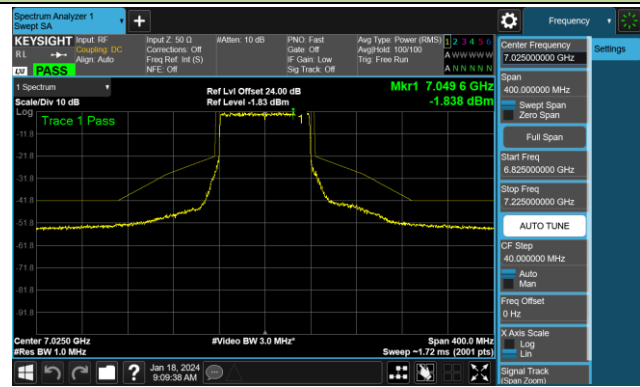

802.11be-EHT160 - Ant 1 (Nss = 2)

Channel 15 (6025MHz)

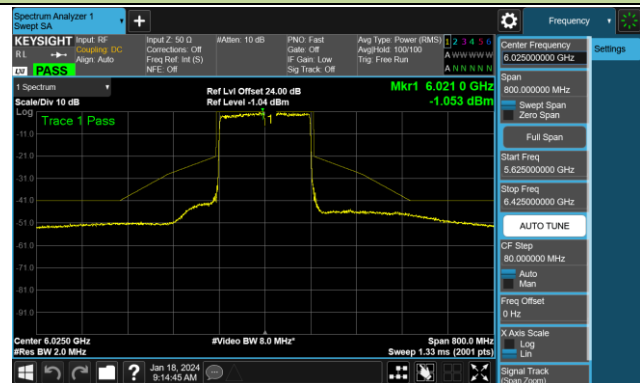

Channel 47 (6185MHz)

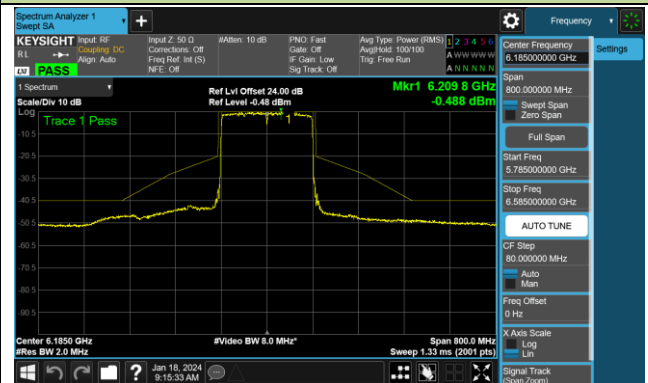

Channel 79 (6345MHz)

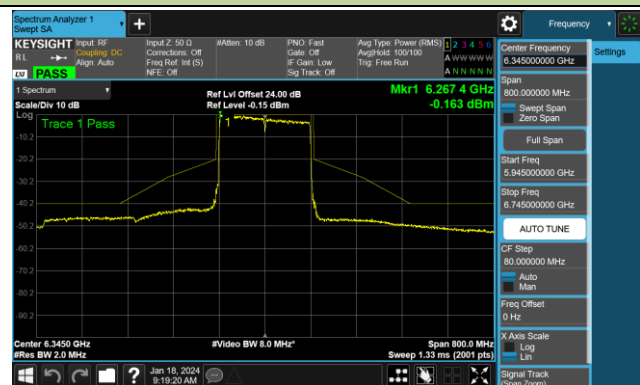

Channel 111 (6505MHz)

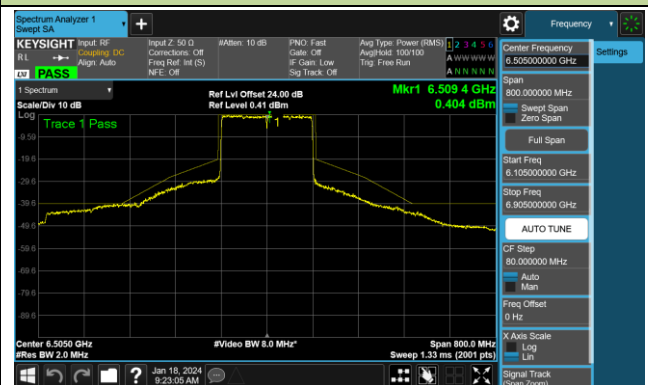

Channel 143 (6665MHz)

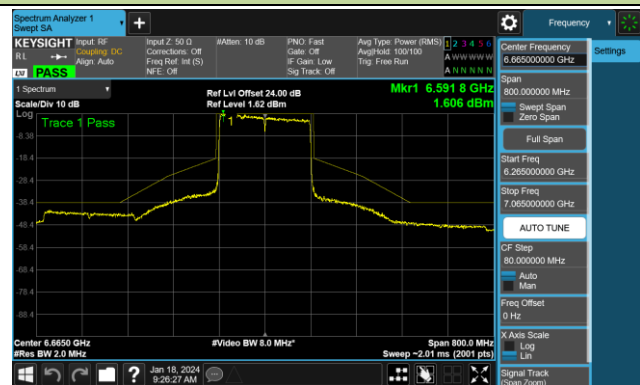

Channel 175 (6825MHz)

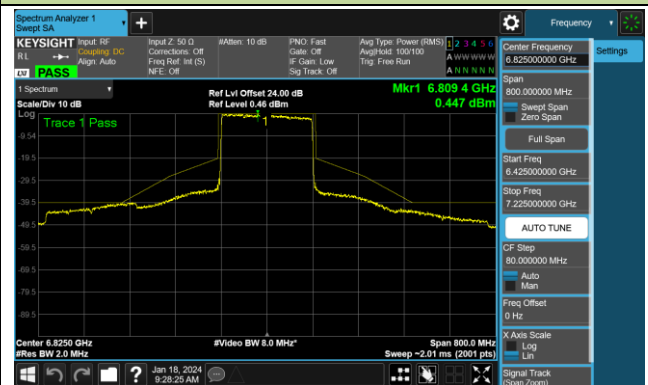

Channel 207 (6985MHz)

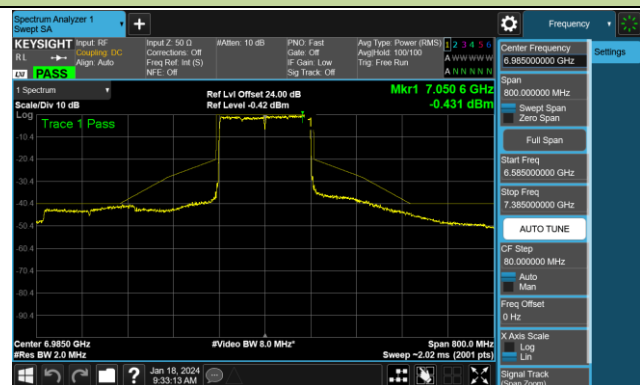

802.11be-EHT320 - Ant 1 (Nss = 2)

Channel 31 (6105MHz)

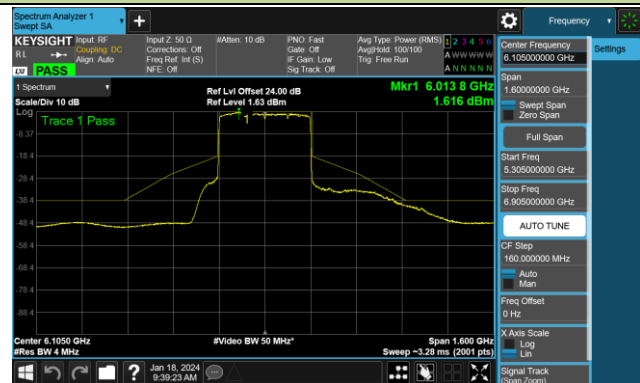

Channel 63 (6265MHz)



Channel 95 (6425MHz)

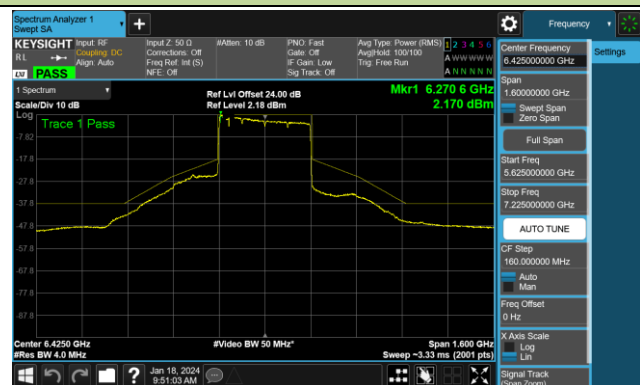

Channel 127 (6585MHz)

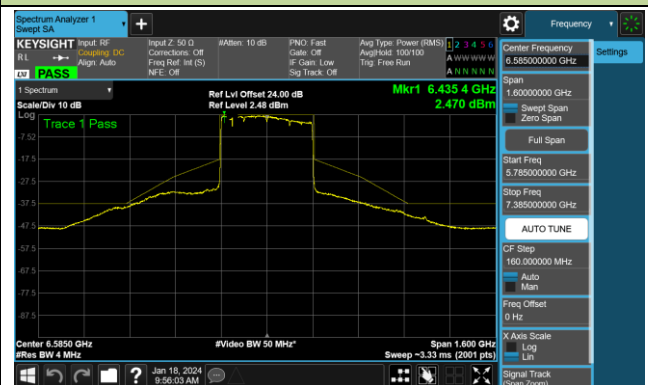

Channel 159 (6745MHz)

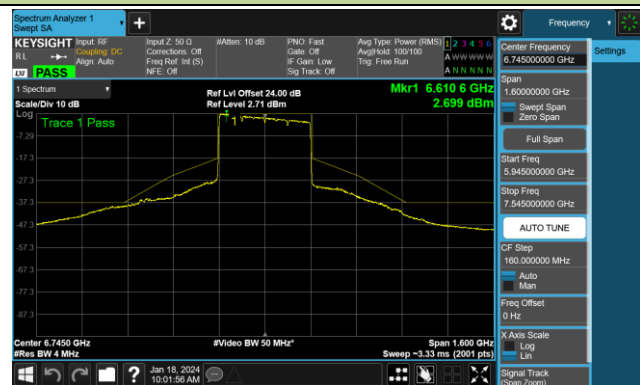

Channel 191 (6905MHz)

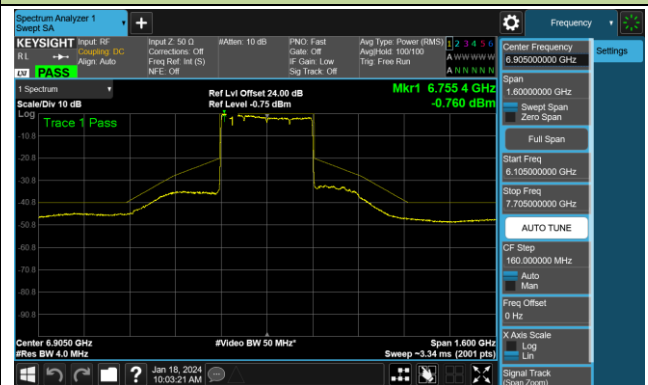

6.6. Frequency Stability Measurement

6.6.1. Test Limit

Manufacturers of U-NII devices are responsible for ensuring frequency stability such that an emission is maintained within the band of operation under all conditions of normal operation as specified in the user's manual.

6.6.2. Test Procedure

Frequency Stability Under Temperature Variations:

The equipment under test was connected to an external AC or DC power supply and input rated voltage. RF output was connected to a frequency counter or spectrum analyzer via feed through attenuators. The EUT was placed inside the temperature chamber. Set the spectrum analyzer RBW low enough to obtain the desired frequency resolution and measure EUT 20°C operating frequency as reference frequency. Turn EUT off and set the chamber temperature to highest. After the temperature stabilized for approximately 30 minutes recorded the frequency. Repeat step measure with 10°C decreased per stage until the lowest temperature reached.

Frequency Stability Under Voltage Variations:

Set chamber temperature to 20°C. Use a variable AC power supply / DC power source to power the EUT and set the voltage to rated voltage. Set the spectrum analyzer RBW low enough to obtain the desired frequency resolution and recorded the frequency.

Reduce the input voltage to specify extreme voltage variation ($\pm 15\%$) and endpoint, record the maximum frequency change.

6.6.3. Test Setup

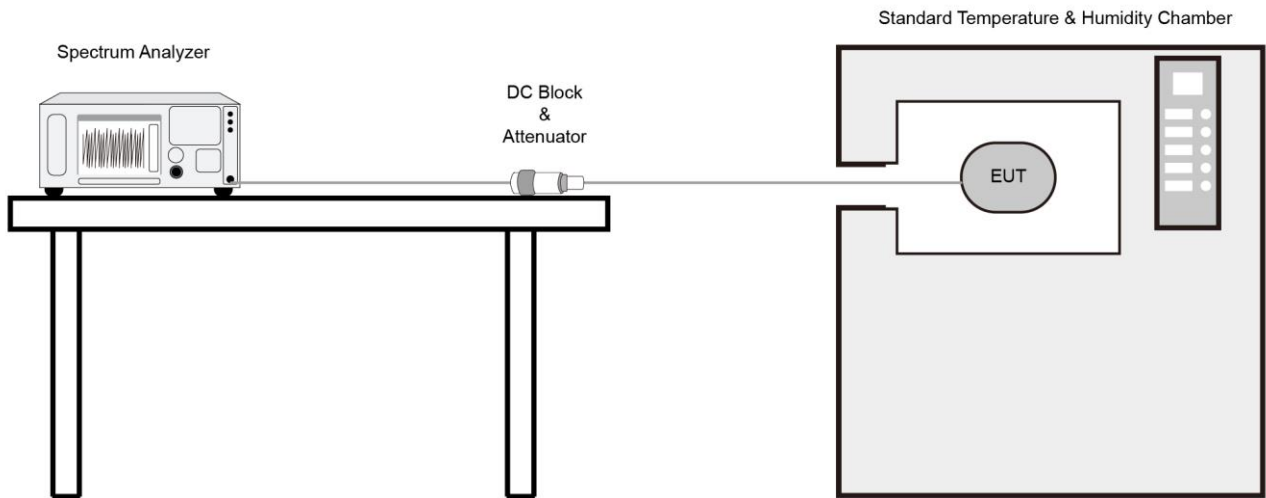

6.6.4. Test Result

Test Site	SR3	Test Engineer	Owen
Test Date	2024/1/15		
Test Mode	6115MHz (Carrier Mode)		

Voltage (%)	Power (VAC)	Temp (°C)	Frequency Tolerance (ppm)			
			0 minutes	2 minutes	5 minutes	10 minutes
100	120	- 30	4.65	4.80	4.82	4.85
		- 20	8.70	8.93	9.08	9.14
		- 10	9.50	9.61	9.62	9.64
		0	9.07	8.61	8.51	8.43
		+ 10	6.73	6.08	5.86	5.68
		+ 20	0.18	0.12	0.10	0.10
		+ 30	-2.54	-2.49	-2.49	-2.49
		+ 40	-4.89	-4.79	-4.74	-4.70
		+ 50	-4.38	-4.57	-4.63	-4.65
115	138	+ 20	0.07	0.07	0.07	0.07
85	102	+ 20	0.08	0.08	0.08	0.08

Note: Frequency Tolerance (ppm) = {[Measured Frequency (Hz) - Declared Frequency (Hz)] / Declared Frequency (Hz)} *10⁶.

6.7. Contention Based Protocol

6.7.1. Test Limit

Unlicensed indoor low power device must detect co-channel radio frequency power that is at least -62dBm (The threshold is referenced to a 0dBi antenna gain.) or low.

Indoor low power device must detect an AWGN signal with 90% (or better) level of certainty.

6.7.2. Test Procedure Used

KDB 987594 D02v02r01- Section I

6.7.3. Test Setting

1. Configure the EUT to transmit with a constant duty cycle.
2. Set the operating parameters of the EUT including power level, operating frequency, modulation and bandwidth.
3. Set the signal analyzer center frequency to the nominal EUT channel center frequency. The span range of the signal analyzer shall be between two times and five times the OBW of the EUT.
Connect the output port of the EUT to the signal analyzer 2. Ensure that the attenuator 2 provides enough attenuation to not overload the signal analyzer 2 receiver.
4. Monitoring the signal analyzer 2, verify the EUT is operating and transmitting with the parameters set at step two.
5. Using an AWGN signal source, generate a 10 MHz-wide AWGN signal. Use Table 1 of KDB 987594 to determine the center frequency of the 10 MHz AWGN signal relative to the EUT's channel bandwidth and center frequency.
6. Set the AWGN signal power to an extremely low level. Connect the AWGN signal source, via a 3-dB splitter, to the signal analyzer 1 and the EUT as shown in below figure.
7. Transmit the AWGN signal (RF ON) and verify its characteristics on the signal analyzer 1.
8. Monitor the signal analyzer 2 to verify if the AWGN signal has been detected and the EUT has ceased transmission. If the EUT continues to transmit, then incrementally increase the AWGN signal power level until the EUT stops transmitting.

9. Determine and record the AWGN signal power level (at the EUT's antenna port) at which the EUT ceased transmission. Repeat the procedure at least 10 times to verify the EUT can detect an AWGN signal with 90% (or better) level of certainty.

10. Refer to Table 1 to determine number of times the detection threshold testing needs to be repeated. If testing is required more than once, then go back to step 5, choose a different center frequency for the AWGN signal and repeat the process.

6.7.4. Test Setup

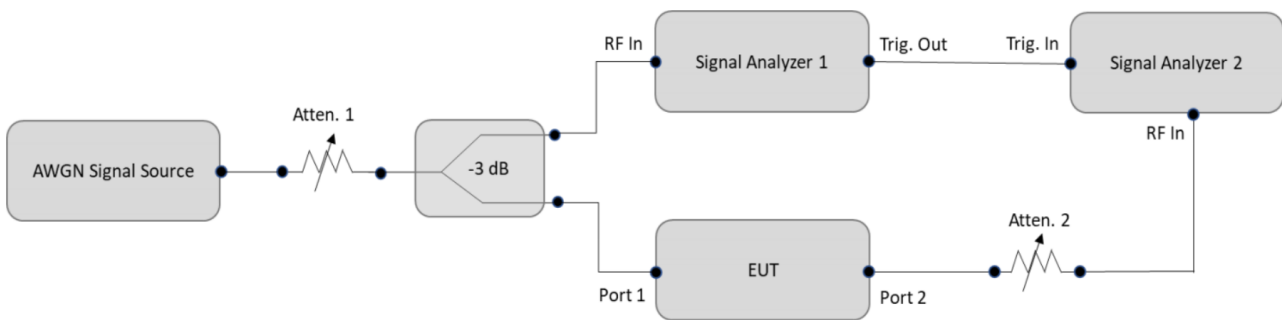

6.7.5. Test Result

Please refer to the report number: 2405RSU009-U1 for Contention Based Protocol test results.

6.8. Radiated Spurious Emission

6.8.1. Test Limit

For 15.407(b)(5) requirement

For transmitters operating within the 5.925-7.125 GHz band: Any emissions outside of the 5.925-7.125 GHz band must not exceed an e.i.r.p. of -27 dBm/MHz.

Refer to 987594 D02 U-NII 6GHz EMC Measurement v01 clause G

Use guidance in KDB 789033 for measurements below 1000 MHz and above 1000 MHz. Unwanted emissions outside of restricted bands are measured with a RMS detector. In addition, 15.35(b) applies where the peak emissions must be limited to no more than 20 dB above the average limit.

All out of band emissions appearing in a restricted band as specified in Section 15.205 of the Title 47CFR must not exceed the limits shown in Table per Section 15.209.

FCC Part 15 Subpart C Paragraph 15.209		
Frequency [MHz]	Field Strength [uV/m]	Measured Distance [Meters]
0.009 - 0.490	2400/F (kHz)	300
0.490 - 1.705	24000/F (kHz)	30
1.705 - 30	30	30
30 - 88	100	3
88 - 216	150	3
216 - 960	200	3
Above 960	500	3

6.8.2. Test Procedure Used

KDB 789033 D02v02r01- Section G

6.8.3. Test Setting

Table 1 - RBW as a function of frequency

Frequency	RBW
9 ~ 150 kHz	200 ~ 300 Hz
0.15 ~ 30 MHz	9 ~ 10 kHz
30 ~ 1000 MHz	100 ~ 120 kHz
> 1000MHz	1MHz

Quasi-Peak Measurements below 1GHz

1. Analyzer center frequency was set to the frequency of the radiated spurious emission of interest
2. Span was set greater than 1MHz
3. RBW = as specified in Table 1
4. Detector = CISPR quasi-peak
5. Sweep time = auto couple
6. Trace was allowed to stabilize

Peak Measurements above 1GHz

1. Analyzer center frequency was set to the frequency of the radiated spurious emission of interest
2. RBW = 1MHz
3. VBW = 3MHz
4. Detector = peak
5. Sweep time = auto couple
6. Trace mode = max hold
7. Trace was allowed to stabilize

Average Measurements above 1GHz (Method VB)

1. Analyzer center frequency was set to the frequency of the radiated spurious emission of interest
2. RBW = 1MHz
3. VBW; If the EUT is configured to transmit with duty cycle $\geq 98\%$, set VBW = 10 Hz.
If the EUT duty cycle is $< 98\%$, set VBW $\geq 1/T$. T is the minimum transmission duration.
4. Detector = Peak
5. Sweep time = auto
6. Trace mode = max hold
7. Trace was allowed to stabilize

6.8.4. Test Setup

Below 1GHz Test Setup:

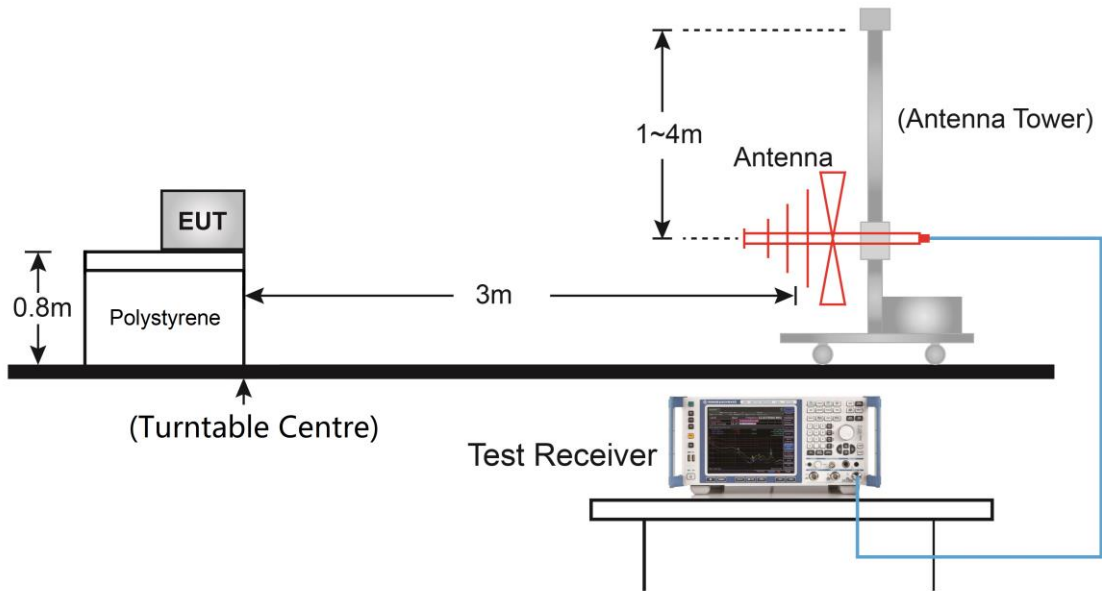

Above 1GHz Test Setup:

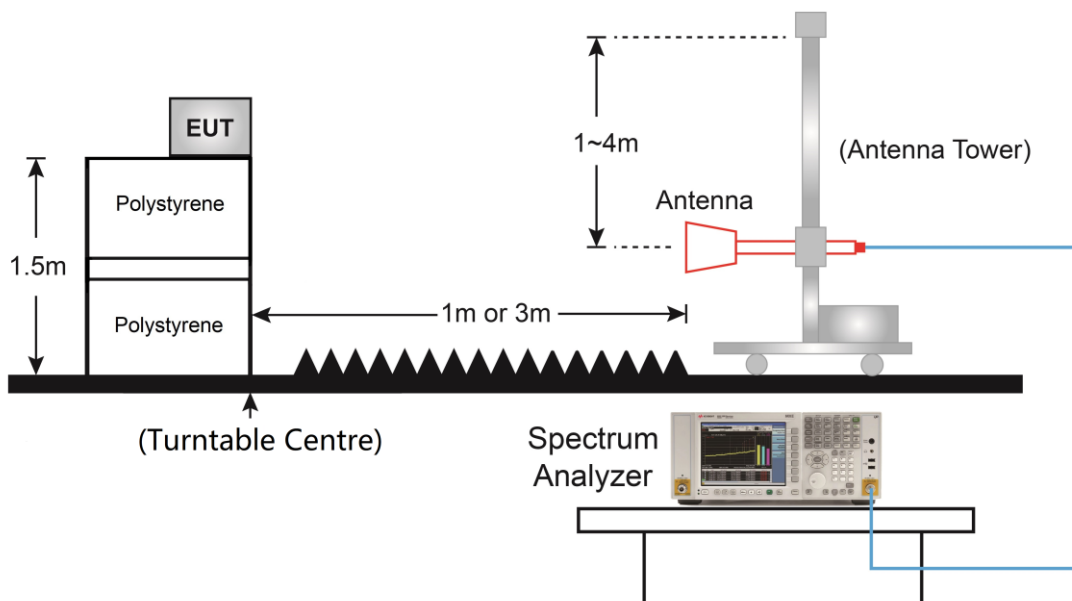

6.8.5. Test Result

EUT	BE11000 Tri-Band Wi-Fi 7 Gaming Router	Date of Test	2024-01-09
Factor	VULB 9162	Temp. / Humidity	21°C /63%
Polarity	Horizontal	Site / Test Engineer	AC2 / Stanley
Test Mode	802.11ax-20MHz_TX_Band5_CH 1_ANT 0+1_NSS1	Test Voltage	AC 120V/60Hz

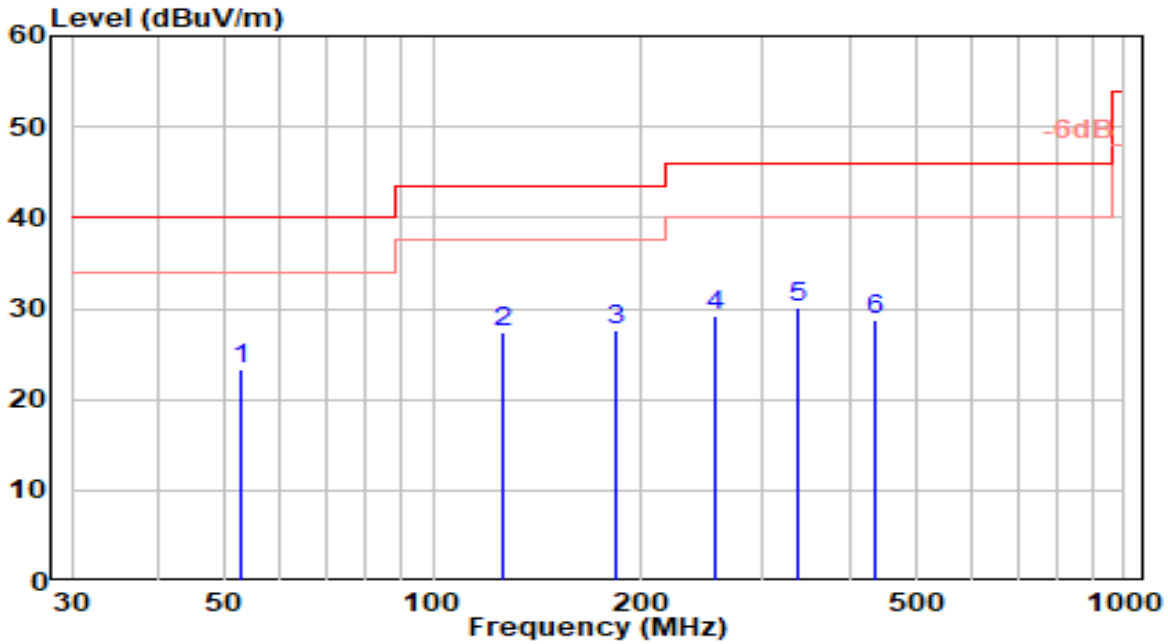

No	Frequency (MHz)	Reading (dBuV)	C.F (dB/m)	Measurement (dBuV/m)	Margin (dB)	Limit (dBuV/m)	Height (cm)	Angle (deg)	Remark (QP/PK/AV)
1	52.710	3.15	20.11	23.27	-16.73	40.00	150	102	QP
2	125.750	11.43	15.96	27.39	-16.11	43.50	150	242	QP
3	* 184.200	10.81	16.83	27.64	-15.86	43.50	100	42	QP
4	254.970	9.25	19.96	29.21	-16.79	46.00	200	189	QP
5	337.780	8.06	22.01	30.07	-15.93	46.00	100	42	QP
6	434.650	5.07	23.66	28.73	-17.27	46.00	150	182	QP

Note:

- "*", means this data is the worst emission level.
- C.F (Correction Factor) = Antenna Factor (dB/m) + Cable Loss (dB).
- Measurement (dBuV/m) = Reading(dBuV) + C.F (Correction Factor).
- The emission levels of other frequencies are very lower than the limit and not show in test report.
- The amplitude of radiated emissions (frequency range from 9kHz to 30MHz) is that proximity to ambient noise, which also are attenuated more than 20dB below the permissible value. Therefore, the data is not presented in the report.

EUT	BE11000 Tri-Band Wi-Fi 7 Gaming Router	Date of Test	2024-01-09
Factor	VULB 9162	Temp. / Humidity	21°C /63%
Polarity	Vertical	Site / Test Engineer	AC2 / Stanley
Test Mode	802.11ax-20MHz_TX_Band5_CH 1_ANT 0+1_NSS1	Test Voltage	AC 120V/60Hz

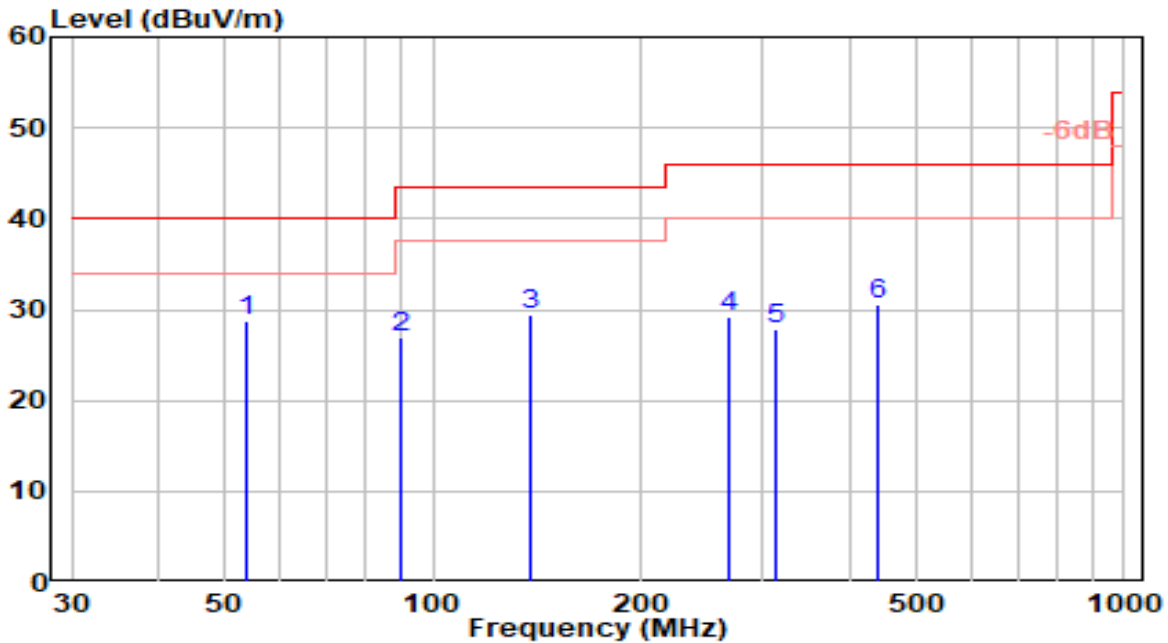

No	Frequency (MHz)	Reading (dBuV)	C.F (dB/m)	Measurement (dBuV/m)	Margin (dB)	Limit (dBuV/m)	Height (cm)	Angle (deg)	Remark (QP/PK/AV)	
1	*	53.640	8.70	20.00	28.70	-11.30	40.00	200	232	QP
2		89.780	10.23	16.76	26.99	-16.51	43.50	200	7	QP
3		138.220	14.56	14.84	29.40	-14.10	43.50	100	7	QP
4		268.610	9.41	19.90	29.31	-16.69	46.00	150	268	QP
5		314.390	6.61	21.14	27.75	-18.25	46.00	150	94	QP
6		438.670	6.95	23.70	30.65	-15.35	46.00	200	7	QP

Note:

- "*", means this data is the worst emission level.
- C.F (Correction Factor) = Antenna Factor (dB/m) + Cable Loss (dB).
- Measurement (dBuV/m) = Reading(dBuV) + C.F (Correction Factor).
- The emission levels of other frequencies are very lower than the limit and not show in test report.
- The amplitude of radiated emissions (frequency range from 9kHz to 30MHz) is that proximity to ambient noise, which also are attenuated more than 20dB below the permissible value. Therefore, the data is not presented in the report.

EUT	BE11000 Tri-Band Wi-Fi 7 Gaming Router	Date of Test	2024-01-09
Factor	VULB 9162	Temp. / Humidity	21°C /63%
Polarity	Horizontal	Site / Test Engineer	AC2 / Stanley
Test Mode	802.11ax-20MHz_TX_Band5_CH 1_ANT 0+1_NSS2	Test Voltage	AC 120V/60Hz

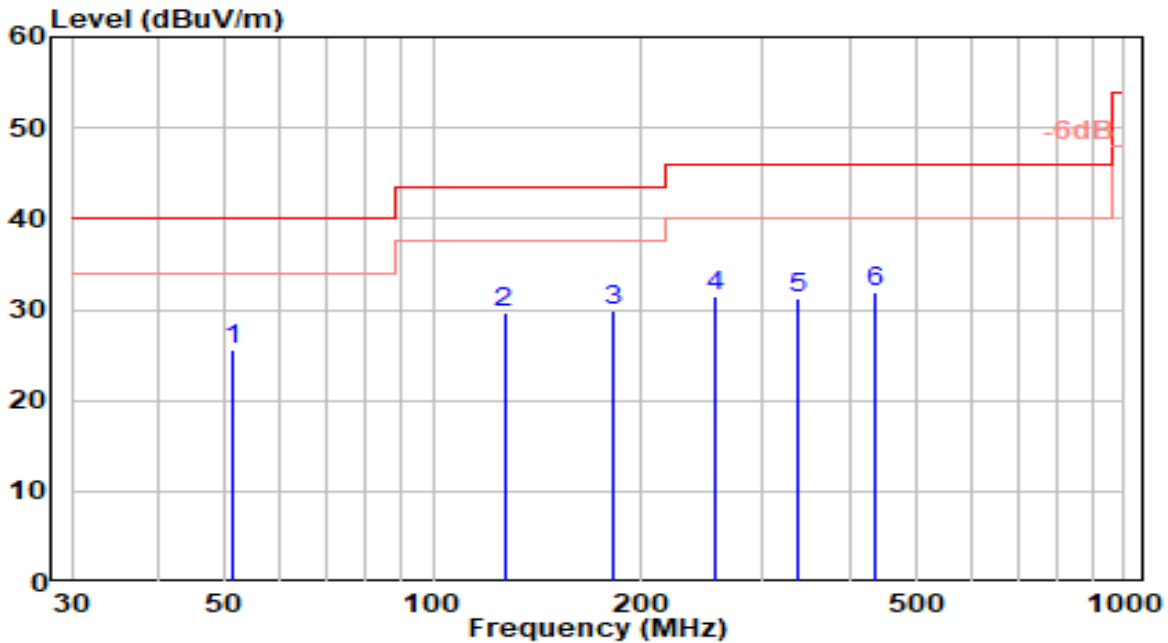

No	Frequency (MHz)	Reading (dBuV)	C.F (dB/m)	Measurement (dBuV/m)	Margin (dB)	Limit (dBuV/m)	Height (cm)	Angle (deg)	Remark (QP/PK/AV)
1	51.380	5.27	20.27	25.54	-14.46	40.00	190	112	QP
2	126.760	13.86	15.80	29.66	-13.84	43.50	160	223	QP
3	* 182.680	13.25	16.66	29.91	-13.59	43.50	110	39	QP
4	255.950	11.51	19.98	31.48	-14.52	46.00	200	201	QP
5	336.630	9.37	21.97	31.34	-14.66	46.00	100	78	QP
6	435.320	8.34	23.67	32.00	-14.00	46.00	150	202	QP

Note:

- "*", means this data is the worst emission level.
- C.F (Correction Factor) = Antenna Factor (dB/m) + Cable Loss (dB).
- Measurement (dBuV/m) = Reading(dBuV) + C.F (Correction Factor).
- The emission levels of other frequencies are very lower than the limit and not show in test report.
- The amplitude of radiated emissions (frequency range from 9kHz to 30MHz) is that proximity to ambient noise, which also are attenuated more than 20dB below the permissible value. Therefore, the data is not presented in the report.

EUT	BE11000 Tri-Band Wi-Fi 7 Gaming Router	Date of Test	2024-01-09
Factor	VULB 9162	Temp. / Humidity	21°C /63%
Polarity	Vertical	Site / Test Engineer	AC2 / Stanley
Test Mode	802.11ax-20MHz_TX_Band5_CH 1_ANT 0+1_NSS2	Test Voltage	AC 120V/60Hz

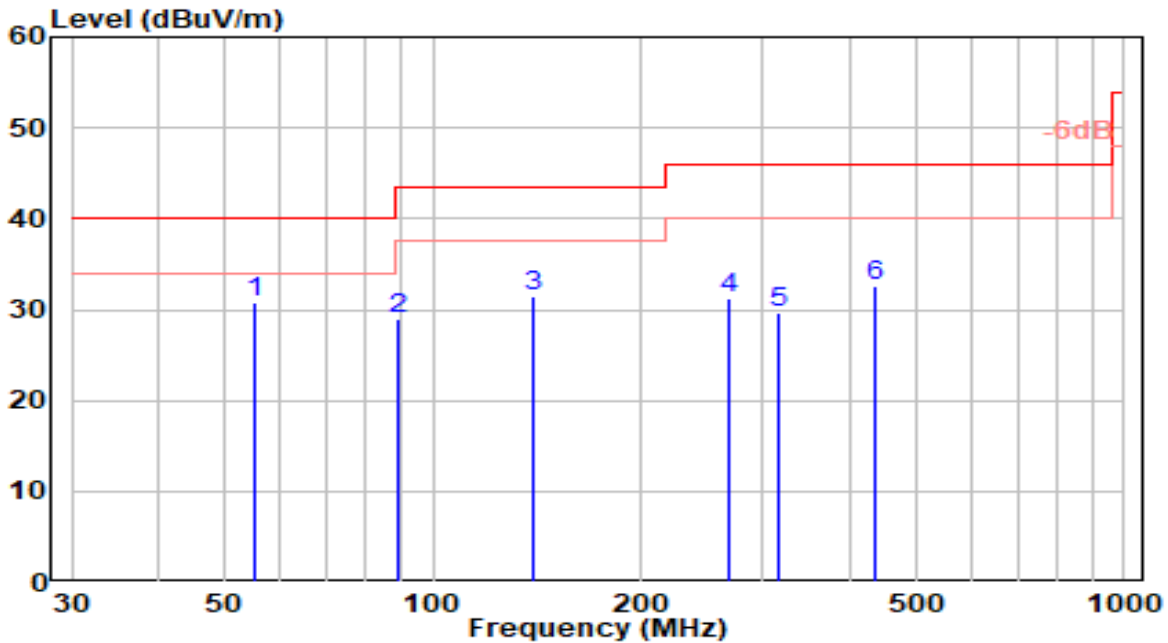

No	Frequency (MHz)	Reading (dBUV)	C.F (dB/m)	Measurement (dBUV/m)	Margin (dB)	Limit (dBUV/m)	Height (cm)	Angle (deg)	Remark (QP/PK/AV)	
1	*	54.970	10.86	19.84	30.70	-9.30	40.00	200	246	QP
2		88.770	12.53	16.46	28.99	-14.51	43.50	100	16	QP
3		139.740	16.64	14.75	31.40	-12.10	43.50	100	20	QP
4		267.630	11.39	19.91	31.31	-14.69	46.00	160	260	QP
5		315.540	8.56	21.19	29.75	-16.25	46.00	200	100	QP
6		438.000	8.95	23.70	32.65	-13.35	46.00	200	31	QP

Note:

1. " *", means this data is the worst emission level.
2. C.F (Correction Factor) = Antenna Factor (dB/m) + Cable Loss (dB).
3. Measurement (dBUV/m) = Reading(dBUV) + C.F (Correction Factor).
4. The emission levels of other frequencies are very lower than the limit and not show in test report.
5. The amplitude of radiated emissions (frequency range from 9kHz to 30MHz) is that proximity to ambient noise, which also are attenuated more than 20dB below the permissible value. Therefore, the data is not presented in the report.

EUT	BE11000 Tri-Band Wi-Fi 7 Gaming Router	Date of Test	2024-01-16
Factor	DRH18-E	Temp. / Humidity	21°C /63%
Polarity	Horizontal	Site / Test Engineer	AC2 / Marvin
Test Mode	802.11ax-20MHz_TX_Band5_CH 1_ANT 0+1 Nss2	Test Voltage	AC 120V/60Hz

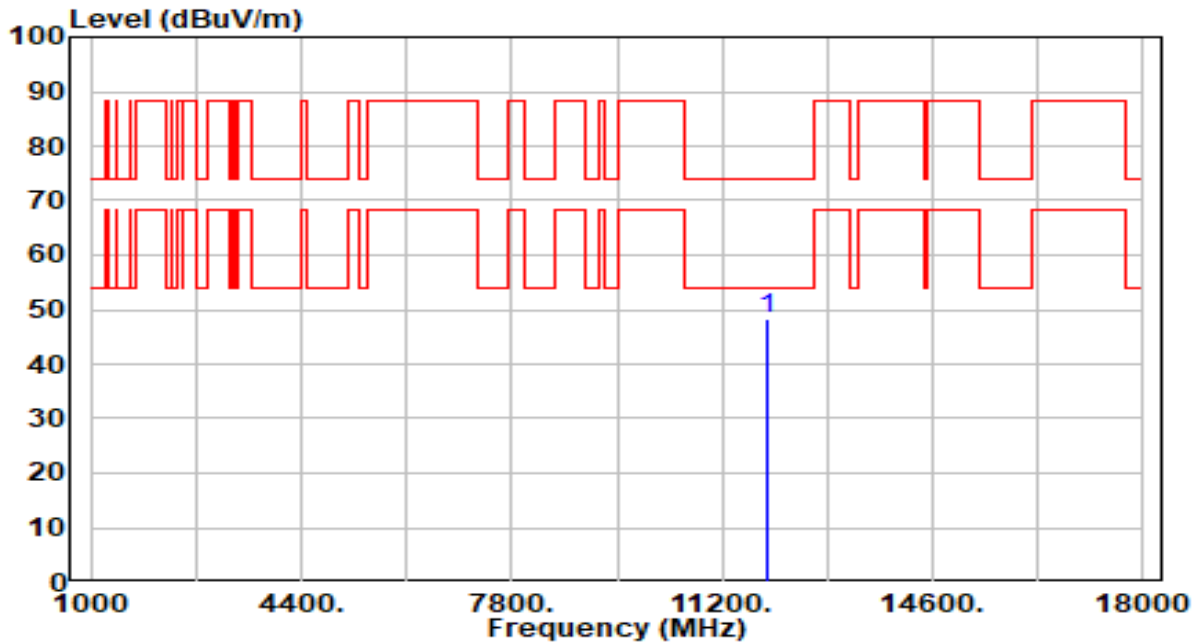

No	Frequency (MHz)	Reading (dBuV)	C.F (dB/m)	Measurement (dBuV/m)	Margin (dB)	Limit (dBuV/m)	Height (cm)	Angle (deg)	Remark (QP/PK/AV)
1	*	42.91	5.39	48.30	-25.70	74.00	100	0	Peak

Note:

1. " *", means this data is the worst emission level.
2. C.F (Correction Factor) = Antenna Factor (dB/m)+ Cable Loss (dB) – Preamplifier(dB).
3. Measurement (dBuV/m) = Reading(dBuV) + C.F (Correction Factor).
4. The emission levels of other frequencies are very lower than the limit and not show in test report.

EUT	BE11000 Tri-Band Wi-Fi 7 Gaming Router	Date of Test	2024-01-16
Factor	DRH18-E	Temp. / Humidity	21°C /63%
Polarity	Vertical	Site / Test Engineer	AC2 / Marvin
Test Mode	802.11ax-20MHz_TX_Band5_CH 1_ANT 0+1 Nss2	Test Voltage	AC 120V/60Hz

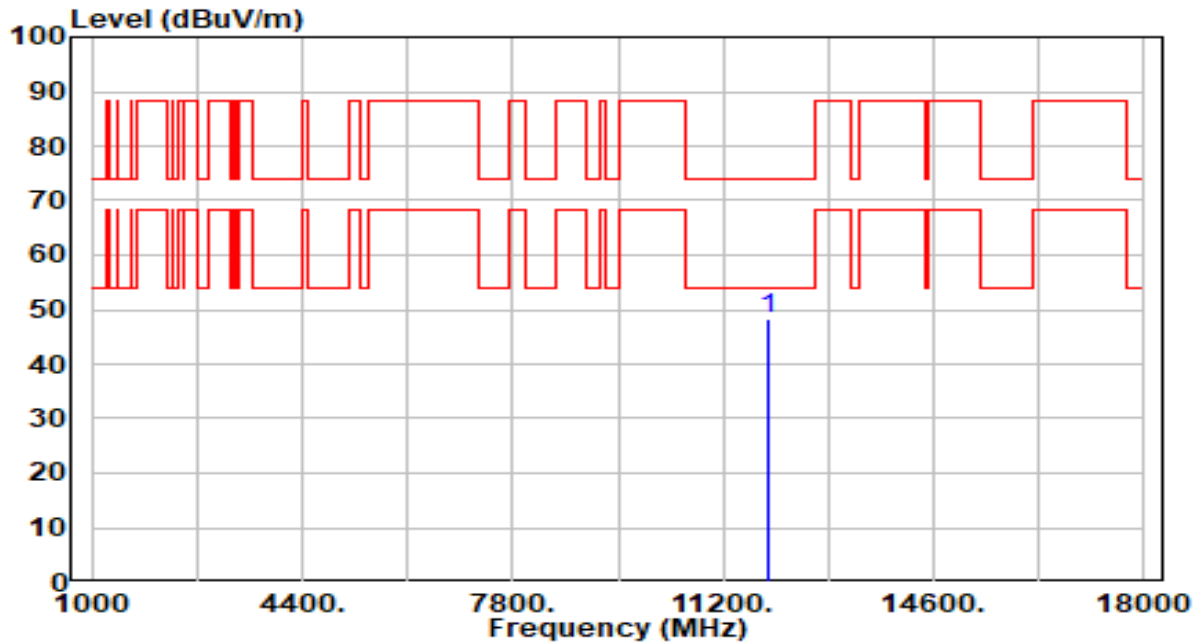

No	Frequency (MHz)	Reading (dBuV)	C.F (dB/m)	Measurement (dBuV/m)	Margin (dB)	Limit (dBuV/m)	Height (cm)	Angle (deg)	Remark (QP/PK/AV)
1	*	43.08	5.39	48.47	-25.53	74.00	200	360	Peak

Note:

1. " *", means this data is the worst emission level.
2. C.F (Correction Factor) = Antenna Factor (dB/m)+ Cable Loss (dB) – Preamplifier(dB).
3. Measurement (dBuV/m) = Reading(dBuV) + C.F (Correction Factor).
4. The emission levels of other frequencies are very lower than the limit and not show in test report.

EUT	BE11000 Tri-Band Wi-Fi 7 Gaming Router	Date of Test	2024-01-16
Factor	DRH18-E	Temp. / Humidity	21°C /63%
Polarity	Horizontal	Site / Test Engineer	AC2 / Marvin
Test Mode	802.11ax-20MHz_TX_Band5_CH 45_ANT 0+1 Nss2	Test Voltage	AC 120V/60Hz

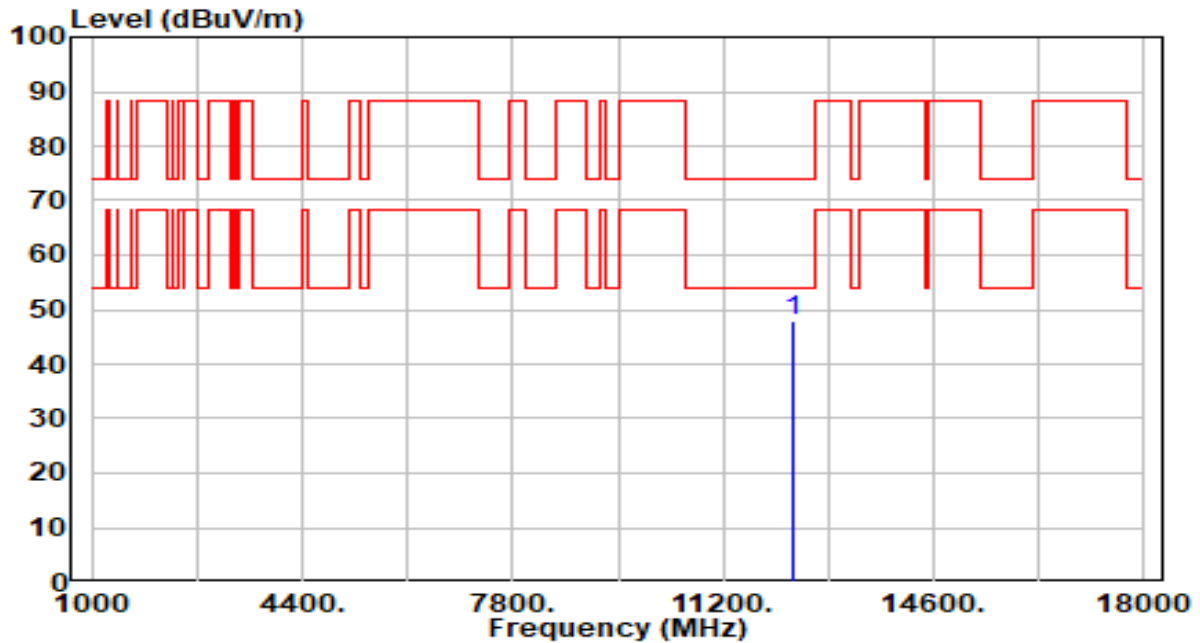

No	Frequency (MHz)	Reading (dBuV)	C.F (dB/m)	Measurement (dBuV/m)	Margin (dB)	Limit (dBuV/m)	Height (cm)	Angle (deg)	Remark (QP/PK/AV)
1	*	41.91	6.09	48.00	-26.00	74.00	200	97	Peak

Note:

- "*", means this data is the worst emission level.
- C.F (Correction Factor) = Antenna Factor (dB/m)+ Cable Loss (dB) – Preamplifier(dB).
- Measurement (dBuV/m) = Reading(dBuV) + C.F (Correction Factor).
- The emission levels of other frequencies are very lower than the limit and not show in test report.

EUT	BE11000 Tri-Band Wi-Fi 7 Gaming Router	Date of Test	2024-01-16
Factor	DRH18-E	Temp. / Humidity	21°C /63%
Polarity	Vertical	Site / Test Engineer	AC2 / Marvin
Test Mode	802.11ax-20MHz_TX_Band5_CH 45_ANT 0+1 Nss2	Test Voltage	AC 120V/60Hz

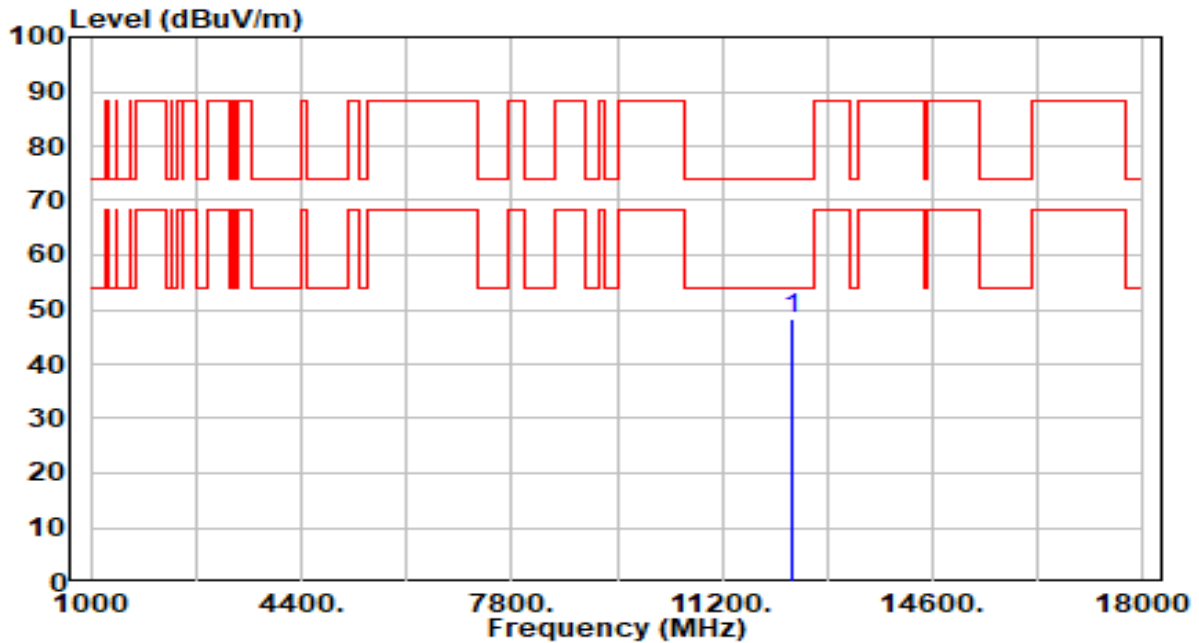

No	Frequency (MHz)	Reading (dBuV)	C.F (dB/m)	Measurement (dBuV/m)	Margin (dB)	Limit (dBuV/m)	Height (cm)	Angle (deg)	Remark (QP/PK/AV)
1	*	42.29	6.09	48.38	-25.62	74.00	200	152	Peak

Note:

1. " *", means this data is the worst emission level.
2. C.F (Correction Factor) = Antenna Factor (dB/m)+ Cable Loss (dB) – Preamplifier(dB).
3. Measurement (dBuV/m) = Reading(dBuV) + C.F (Correction Factor).
4. The emission levels of other frequencies are very lower than the limit and not show in test report.

EUT	BE11000 Tri-Band Wi-Fi 7 Gaming Router	Date of Test	2024-01-16
Factor	DRH18-E	Temp. / Humidity	21°C /63%
Polarity	Horizontal	Site / Test Engineer	AC2 / Marvin
Test Mode	802.11ax-20MHz_TX_Band5_CH 93_ANT 0+1 Nss2	Test Voltage	AC 120V/60Hz

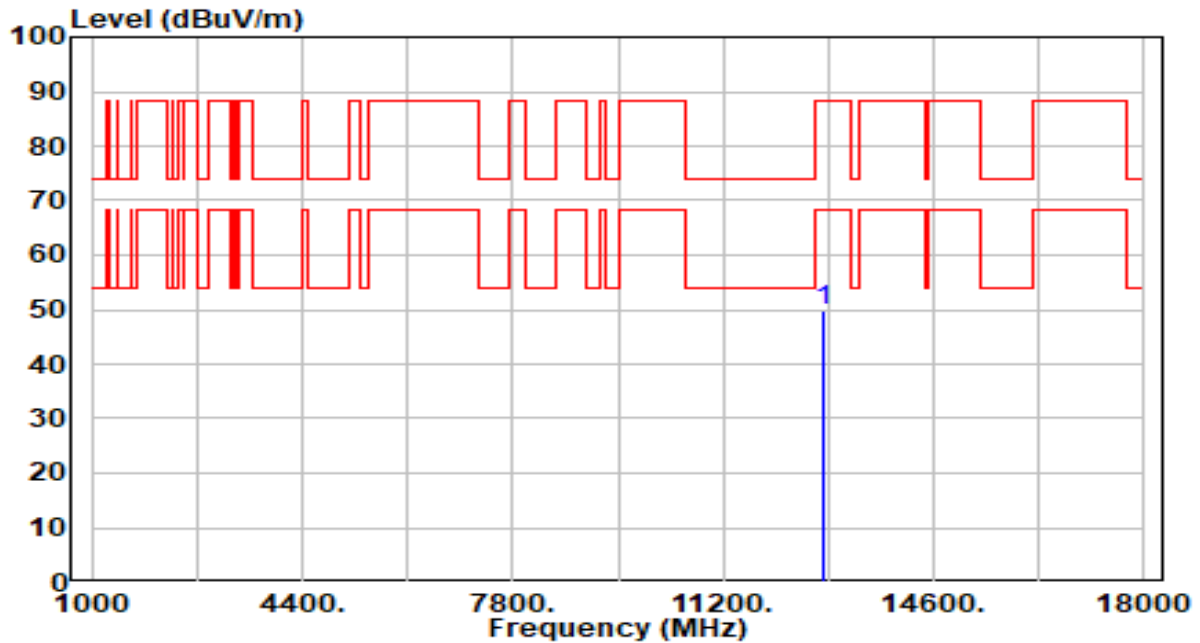

No	Frequency (MHz)	Reading (dBuV)	C.F (dB/m)	Measurement (dBuV/m)	Margin (dB)	Limit (dBuV/m)	Height (cm)	Angle (deg)	Remark (QP/PK/AV)
1	*	42.74	6.92	49.65	-38.55	88.20	200	0	Peak

Note:

- "*", means this data is the worst emission level.
- C.F (Correction Factor) = Antenna Factor (dB/m)+ Cable Loss (dB) – Preamplifier(dB).
- Measurement (dBuV/m) = Reading(dBuV) + C.F (Correction Factor).
- The emission levels of other frequencies are very lower than the limit and not show in test report.

EUT	BE11000 Tri-Band Wi-Fi 7 Gaming Router	Date of Test	2024-01-16
Factor	DRH18-E	Temp. / Humidity	21°C /63%
Polarity	Vertical	Site / Test Engineer	AC2 / Marvin
Test Mode	802.11ax-20MHz_TX_Band5_CH 93_ANT 0+1 Nss2	Test Voltage	AC 120V/60Hz

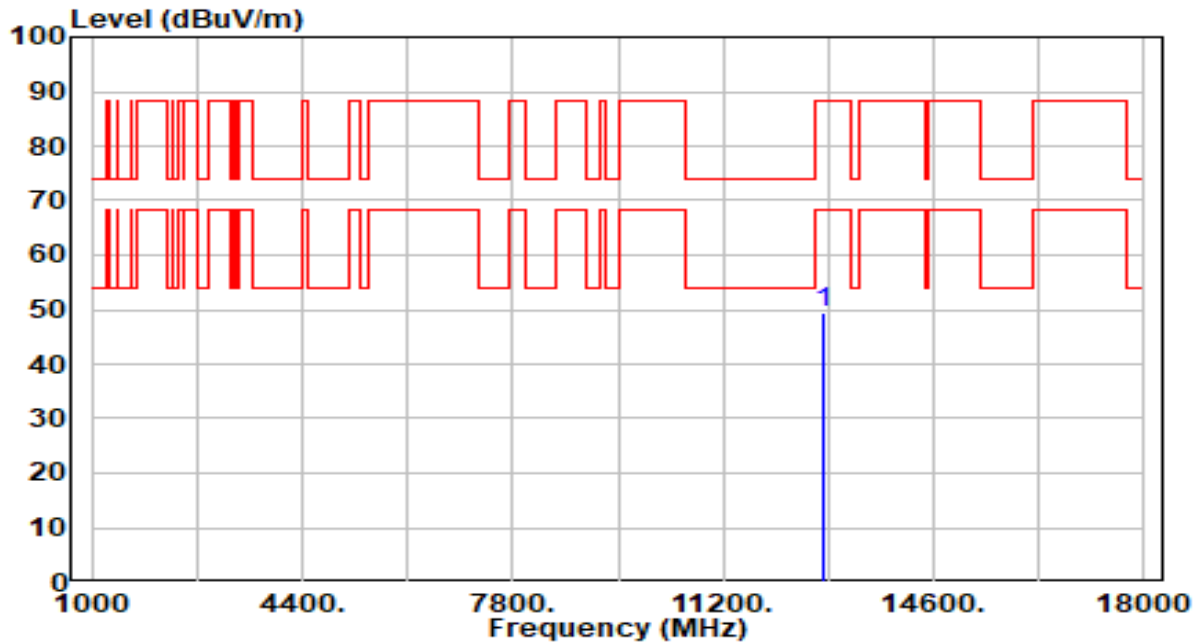

No	Frequency (MHz)	Reading (dBuV)	C.F (dB/m)	Measurement (dBuV/m)	Margin (dB)	Limit (dBuV/m)	Height (cm)	Angle (deg)	Remark (QP/PK/AV)
1	*	42.67	6.92	49.59	-38.61	88.20	200	192	Peak

Note:

1. " *", means this data is the worst emission level.
2. C.F (Correction Factor) = Antenna Factor (dB/m)+ Cable Loss (dB) – Preamplifier(dB).
3. Measurement (dBuV/m) = Reading(dBuV) + C.F (Correction Factor).
4. The emission levels of other frequencies are very lower than the limit and not show in test report.

EUT	BE11000 Tri-Band Wi-Fi 7 Gaming Router	Date of Test	2024-01-16
Factor	DRH18-E	Temp. / Humidity	21°C /63%
Polarity	Horizontal	Site / Test Engineer	AC2 / Marvin
Test Mode	802.11ax-20MHz_TX_Band6_CH 97_ANT 0+1 Nss2	Test Voltage	AC 120V/60Hz

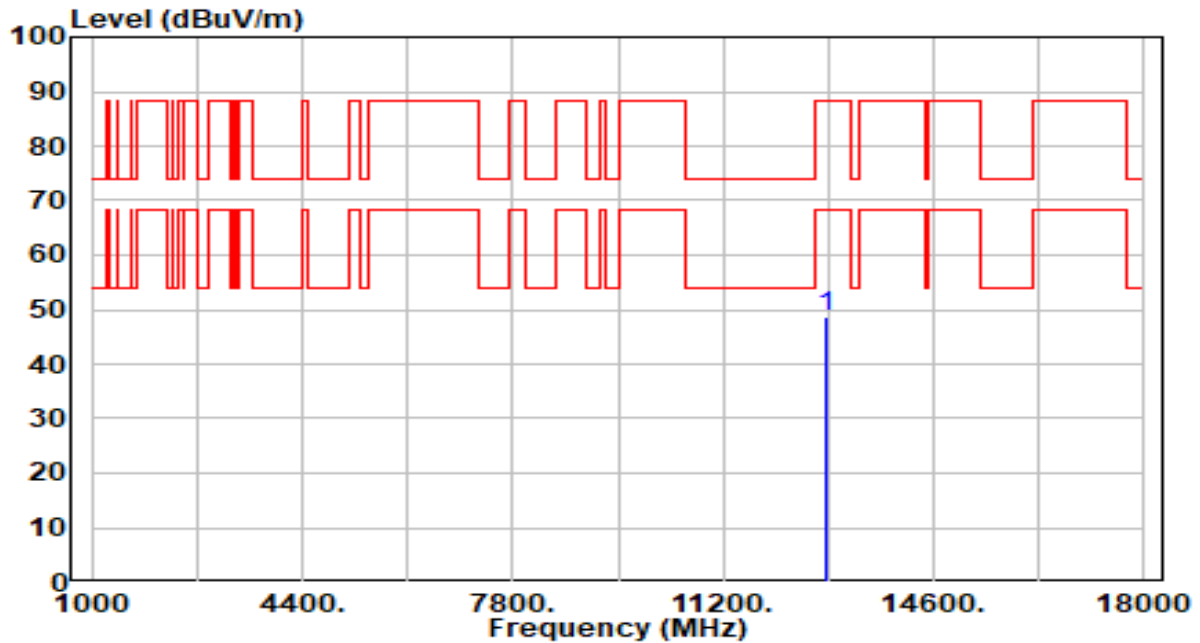

No	Frequency (MHz)	Reading (dBuV)	C.F (dB/m)	Measurement (dBuV/m)	Margin (dB)	Limit (dBuV/m)	Height (cm)	Angle (deg)	Remark (QP/PK/AV)
1	*	41.68	6.91	48.59	-39.61	88.20	200	31	Peak

Note:

1. " *", means this data is the worst emission level.
2. C.F (Correction Factor) = Antenna Factor (dB/m)+ Cable Loss (dB) – Preamplifier(dB).
3. Measurement (dBuV/m) = Reading(dBuV) + C.F (Correction Factor).
4. The emission levels of other frequencies are very lower than the limit and not show in test report.

EUT	BE11000 Tri-Band Wi-Fi 7 Gaming Router	Date of Test	2024-01-16
Factor	DRH18-E	Temp. / Humidity	21°C /63%
Polarity	Vertical	Site / Test Engineer	AC2 / Marvin
Test Mode	802.11ax-20MHz_TX_Band6_CH 97_ANT 0+1 Nss2	Test Voltage	AC 120V/60Hz

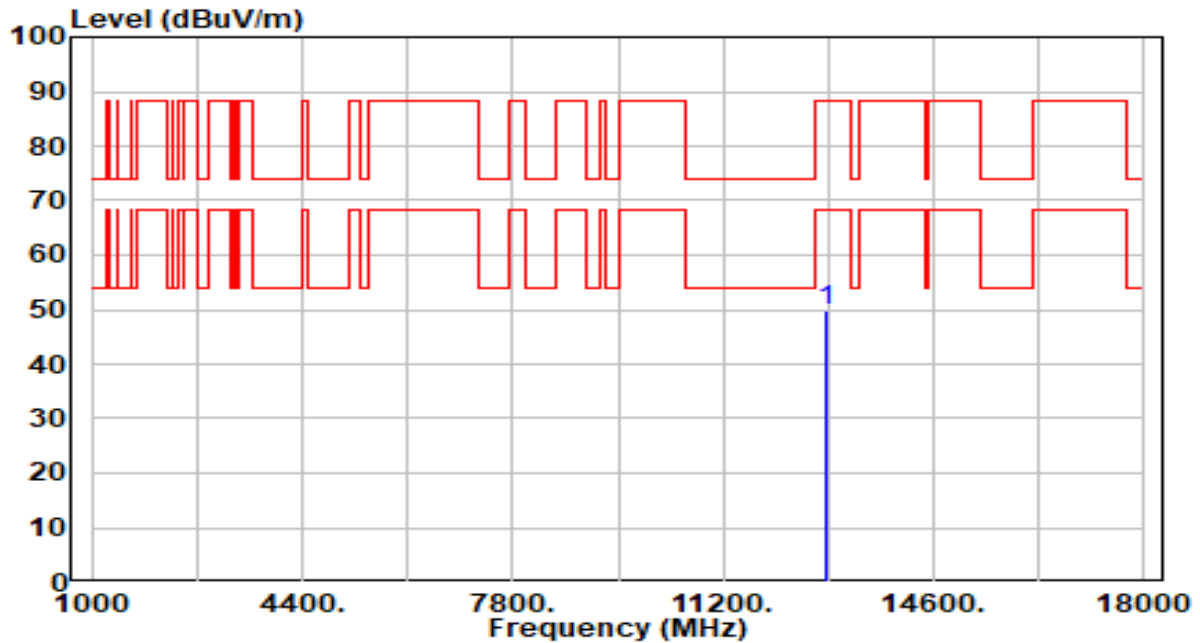

No	Frequency (MHz)	Reading (dBuV)	C.F (dB/m)	Measurement (dBuV/m)	Margin (dB)	Limit (dBuV/m)	Height (cm)	Angle (deg)	Remark (QP/PK/AV)
1	*	43.04	6.91	49.94	-38.26	88.20	200	162	Peak

Note:

- "*", means this data is the worst emission level.
- C.F (Correction Factor) = Antenna Factor (dB/m)+ Cable Loss (dB) – Preamplifier(dB).
- Measurement (dBuV/m) = Reading(dBuV) + C.F (Correction Factor).
- The emission levels of other frequencies are very lower than the limit and not show in test report.

EUT	BE11000 Tri-Band Wi-Fi 7 Gaming Router	Date of Test	2024-01-16
Factor	DRH18-E	Temp. / Humidity	21°C /63%
Polarity	Horizontal	Site / Test Engineer	AC2 / Marvin
Test Mode	802.11ax-20MHz_TX_Band6_CH 105_ANT 0+1 Nss2	Test Voltage	AC 120V/60Hz

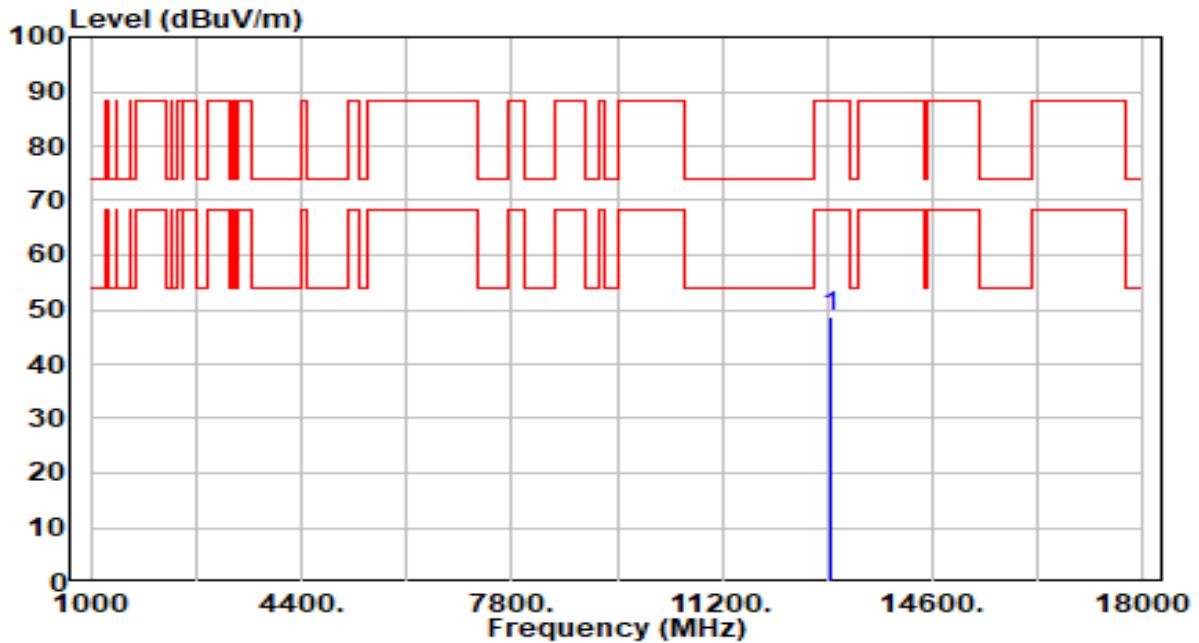

No	Frequency (MHz)	Reading (dBuV)	C.F (dB/m)	Measurement (dBuV/m)	Margin (dB)	Limit (dBuV/m)	Height (cm)	Angle (deg)	Remark (QP/PK/AV)
1	*	41.90	6.88	48.78	-39.42	88.20	200	31	Peak

Note:

- "*", means this data is the worst emission level.
- C.F (Correction Factor) = Antenna Factor (dB/m)+ Cable Loss (dB) – Preamplifier(dB).
- Measurement (dBuV/m) = Reading(dBuV) + C.F (Correction Factor).
- The emission levels of other frequencies are very lower than the limit and not show in test report.

EUT	BE11000 Tri-Band Wi-Fi 7 Gaming Router	Date of Test	2024-01-16
Factor	DRH18-E	Temp. / Humidity	21°C /63%
Polarity	Vertical	Site / Test Engineer	AC2 / Marvin
Test Mode	802.11ax-20MHz_TX_Band6_CH 105_ANT 0+1 Nss2	Test Voltage	AC 120V/60Hz

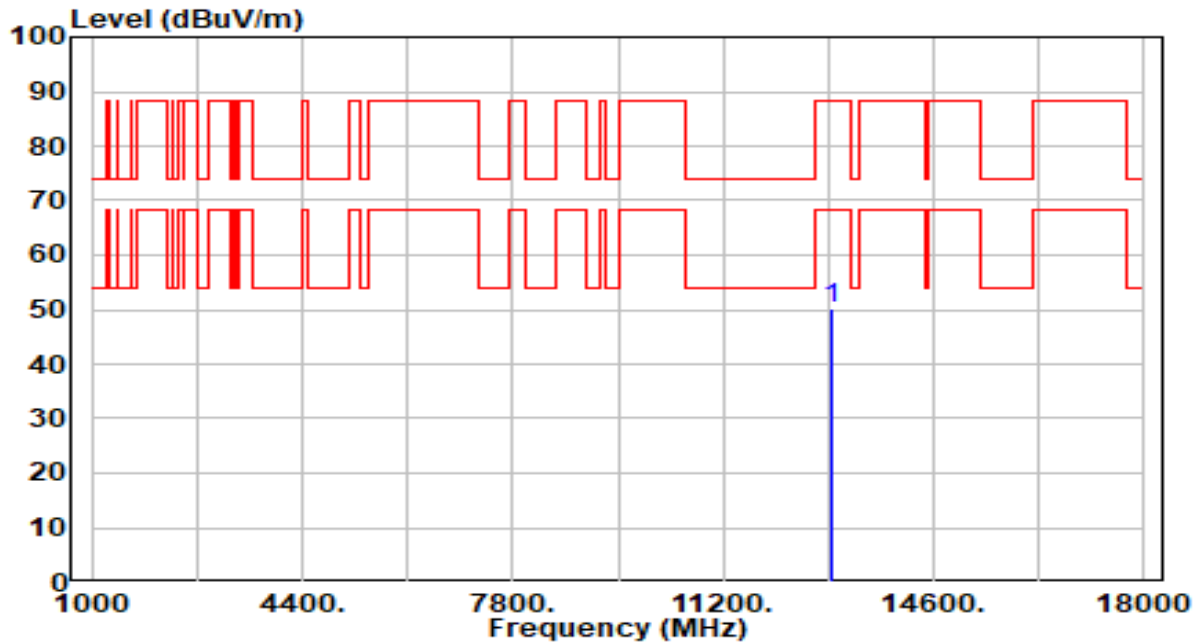

No	Frequency (MHz)	Reading (dBuV)	C.F (dB/m)	Measurement (dBuV/m)	Margin (dB)	Limit (dBuV/m)	Height (cm)	Angle (deg)	Remark (QP/PK/AV)
1	*	43.32	6.88	50.20	-38.00	88.20	200	345	Peak

Note:

- "*", means this data is the worst emission level.
- C.F (Correction Factor) = Antenna Factor (dB/m)+ Cable Loss (dB) – Preamplifier(dB).
- Measurement (dBuV/m) = Reading(dBuV) + C.F (Correction Factor).
- The emission levels of other frequencies are very lower than the limit and not show in test report.

EUT	BE11000 Tri-Band Wi-Fi 7 Gaming Router	Date of Test	2024-01-16
Factor	DRH18-E	Temp. / Humidity	21°C /63%
Polarity	Horizontal	Site / Test Engineer	AC2 / Marvin
Test Mode	802.11ax-20MHz_TX_Band6_CH 113_ANT 0+1 Nss2	Test Voltage	AC 120V/60Hz

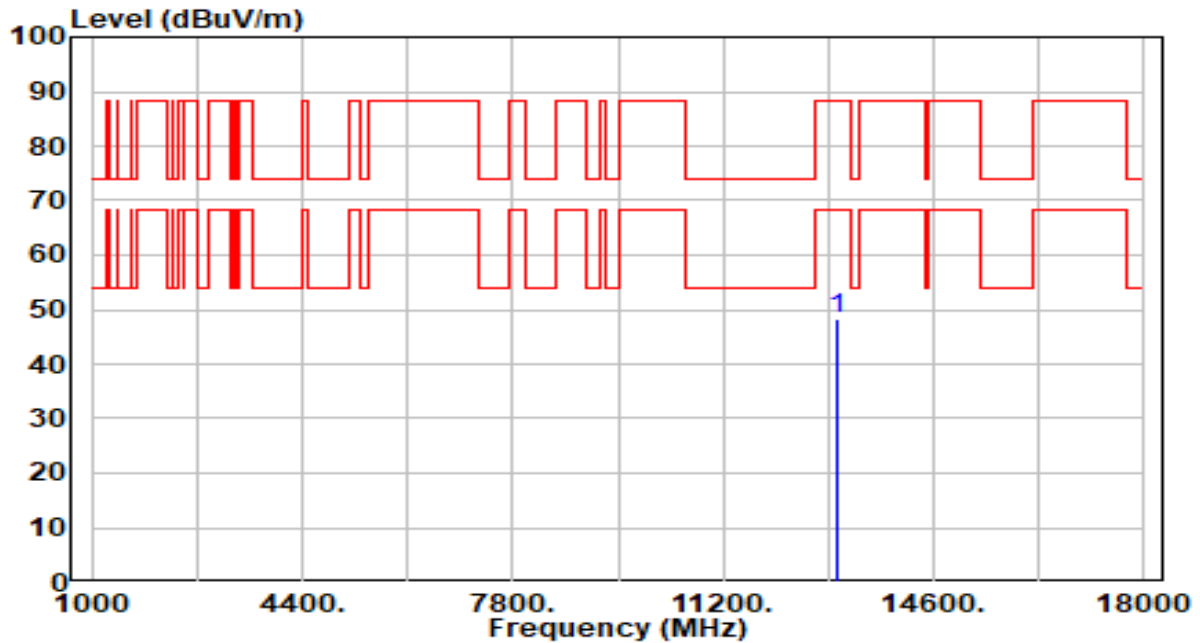

No	Frequency (MHz)	Reading (dBuV)	C.F (dB/m)	Measurement (dBuV/m)	Margin (dB)	Limit (dBuV/m)	Height (cm)	Angle (deg)	Remark (QP/PK/AV)
1	*	41.39	6.86	48.25	-39.95	88.20	200	181	Peak

Note:

1. " *", means this data is the worst emission level.
2. C.F (Correction Factor) = Antenna Factor (dB/m)+ Cable Loss (dB) – Preamplifier(dB).
3. Measurement (dBuV/m) = Reading(dBuV) + C.F (Correction Factor).
4. The emission levels of other frequencies are very lower than the limit and not show in test report.

EUT	BE11000 Tri-Band Wi-Fi 7 Gaming Router	Date of Test	2024-01-16
Factor	DRH18-E	Temp. / Humidity	21°C /63%
Polarity	Vertical	Site / Test Engineer	AC2 / Marvin
Test Mode	802.11ax-20MHz_TX_Band6_CH 113_ANT 0+1 Nss2	Test Voltage	AC 120V/60Hz

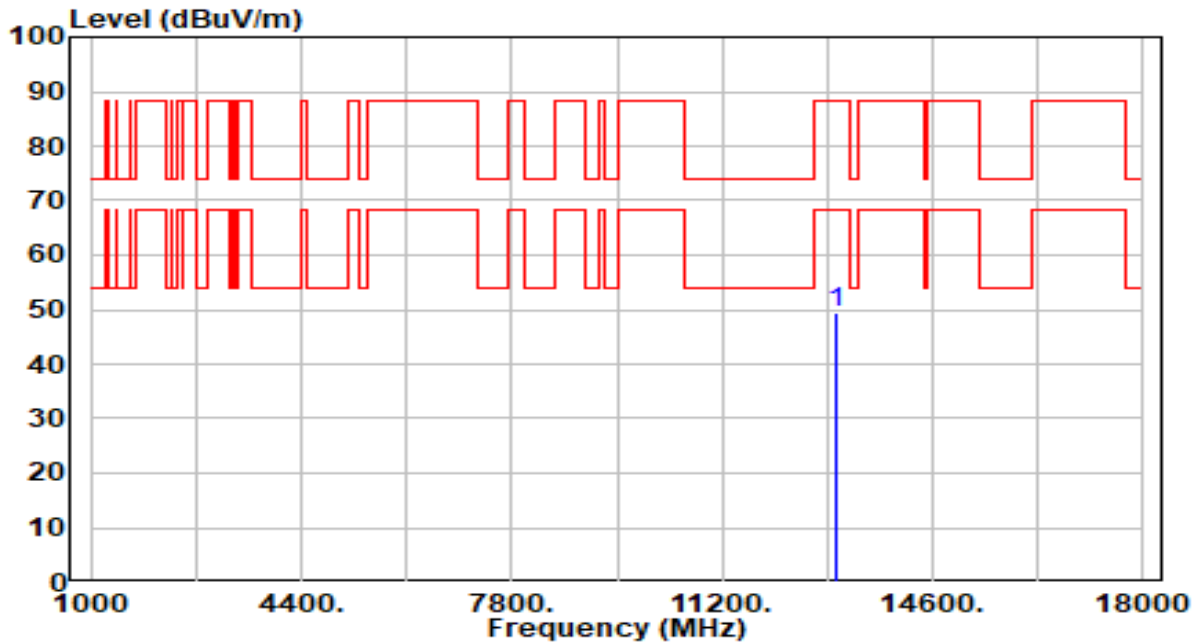

No	Frequency (MHz)	Reading (dBuV)	C.F (dB/m)	Measurement (dBuV/m)	Margin (dB)	Limit (dBuV/m)	Height (cm)	Angle (deg)	Remark (QP/PK/AV)	
1	*	13030.000	42.59	6.86	49.44	-38.76	88.20	200	161	Peak

Note:

1. " *", means this data is the worst emission level.
2. C.F (Correction Factor) = Antenna Factor (dB/m)+ Cable Loss (dB) – Preamplifier(dB).
3. Measurement (dBuV/m) = Reading(dBuV) + C.F (Correction Factor).
4. The emission levels of other frequencies are very lower than the limit and not show in test report.

EUT	BE11000 Tri-Band Wi-Fi 7 Gaming Router	Date of Test	2024-01-16
Factor	DRH18-E	Temp. / Humidity	21°C /63%
Polarity	Horizontal	Site / Test Engineer	AC2 / Marvin
Test Mode	802.11ax-20MHz_TX_Band7_CH 117_ANT 0+1 Nss2	Test Voltage	AC 120V/60Hz

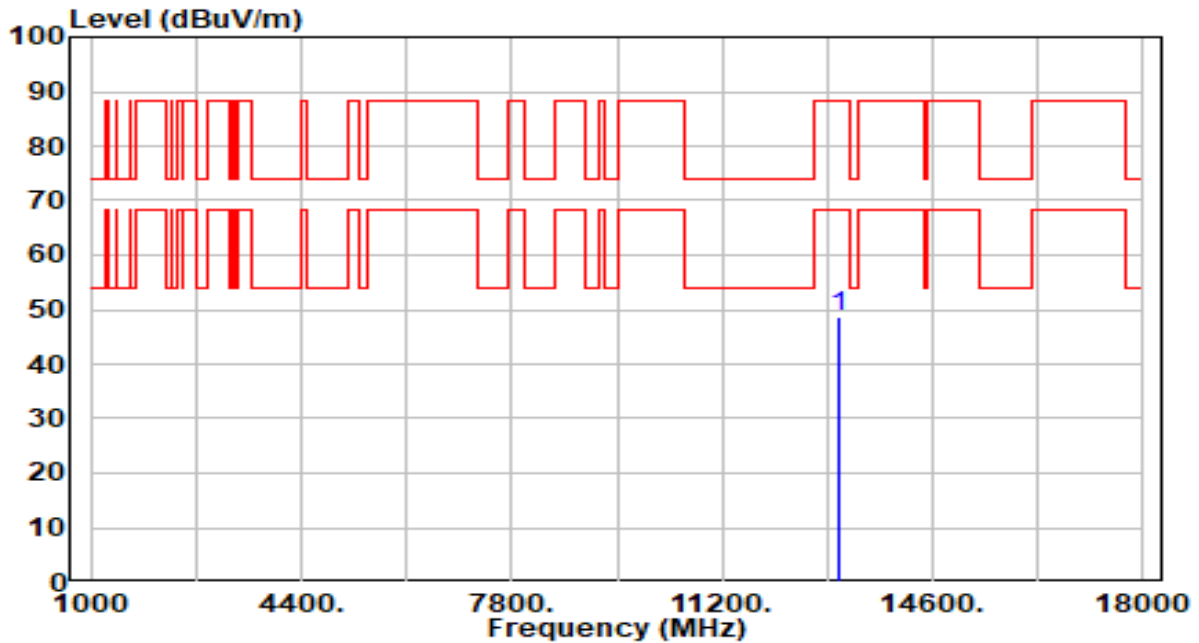

No	Frequency (MHz)	Reading (dBuV)	C.F (dB/m)	Measurement (dBuV/m)	Margin (dB)	Limit (dBuV/m)	Height (cm)	Angle (deg)	Remark (QP/PK/AV)
1	*	41.70	6.84	48.54	-39.66	88.20	200	308	Peak

Note:

1. " *", means this data is the worst emission level.
2. C.F (Correction Factor) = Antenna Factor (dB/m)+ Cable Loss (dB) – Preamplifier(dB).
3. Measurement (dBuV/m) = Reading(dBuV) + C.F (Correction Factor).
4. The emission levels of other frequencies are very lower than the limit and not show in test report.

EUT	BE11000 Tri-Band Wi-Fi 7 Gaming Router	Date of Test	2024-01-16
Factor	DRH18-E	Temp. / Humidity	21°C /63%
Polarity	Vertical	Site / Test Engineer	AC2 / Marvin
Test Mode	802.11ax-20MHz_TX_Band7_CH 117_ANT 0+1 Nss2	Test Voltage	AC 120V/60Hz

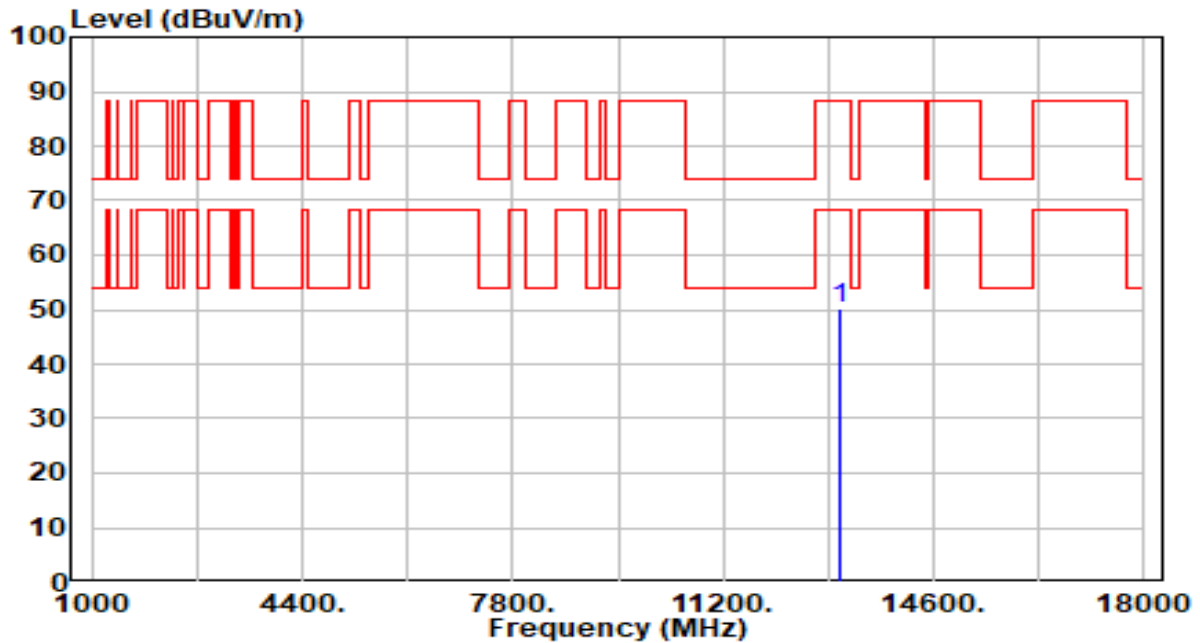

No	Frequency (MHz)	Reading (dBuV)	C.F (dB/m)	Measurement (dBuV/m)	Margin (dB)	Limit (dBuV/m)	Height (cm)	Angle (deg)	Remark (QP/PK/AV)
1	*	43.53	6.84	50.37	-37.83	88.20	200	131	Peak

Note:

- "*", means this data is the worst emission level.
- C.F (Correction Factor) = Antenna Factor (dB/m)+ Cable Loss (dB) – Preamplifier(dB).
- Measurement (dBuV/m) = Reading(dBuV) + C.F (Correction Factor).
- The emission levels of other frequencies are very lower than the limit and not show in test report.

EUT	BE11000 Tri-Band Wi-Fi 7 Gaming Router	Date of Test	2024-01-16
Factor	DRH18-E	Temp. / Humidity	21°C /63%
Polarity	Horizontal	Site / Test Engineer	AC2 / Marvin
Test Mode	802.11ax-20MHz_TX_Band7_CH 149_ANT 0+1 Nss2	Test Voltage	AC 120V/60Hz

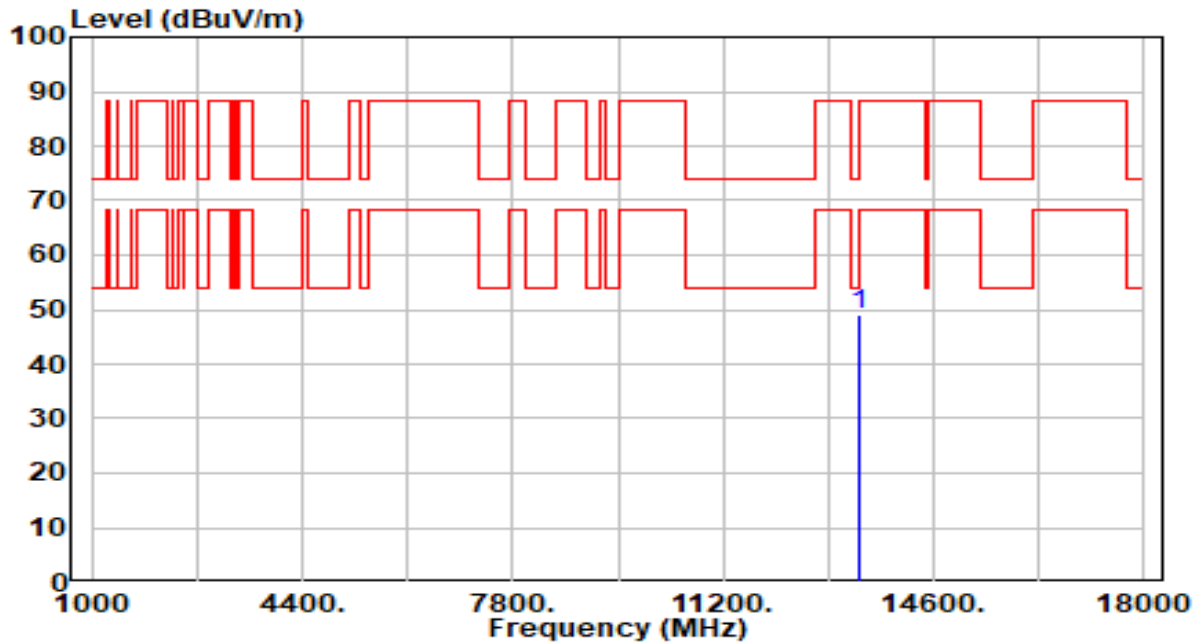

No	Frequency (MHz)	Reading (dBuV)	C.F (dB/m)	Measurement (dBuV/m)	Margin (dB)	Limit (dBuV/m)	Height (cm)	Angle (deg)	Remark (QP/PK/AV)
1	*	42.17	6.82	48.98	-25.02	74.00	200	279	Peak

Note:

- "*", means this data is the worst emission level.
- C.F (Correction Factor) = Antenna Factor (dB/m)+ Cable Loss (dB) – Preamplifier(dB).
- Measurement (dBuV/m) = Reading(dBuV) + C.F (Correction Factor).
- The emission levels of other frequencies are very lower than the limit and not show in test report.

EUT	BE11000 Tri-Band Wi-Fi 7 Gaming Router	Date of Test	2024-01-16
Factor	DRH18-E	Temp. / Humidity	21°C /63%
Polarity	Vertical	Site / Test Engineer	AC2 / Marvin
Test Mode	802.11ax-20MHz_TX_Band7_CH 149_ANT 0+1 Nss2	Test Voltage	AC 120V/60Hz

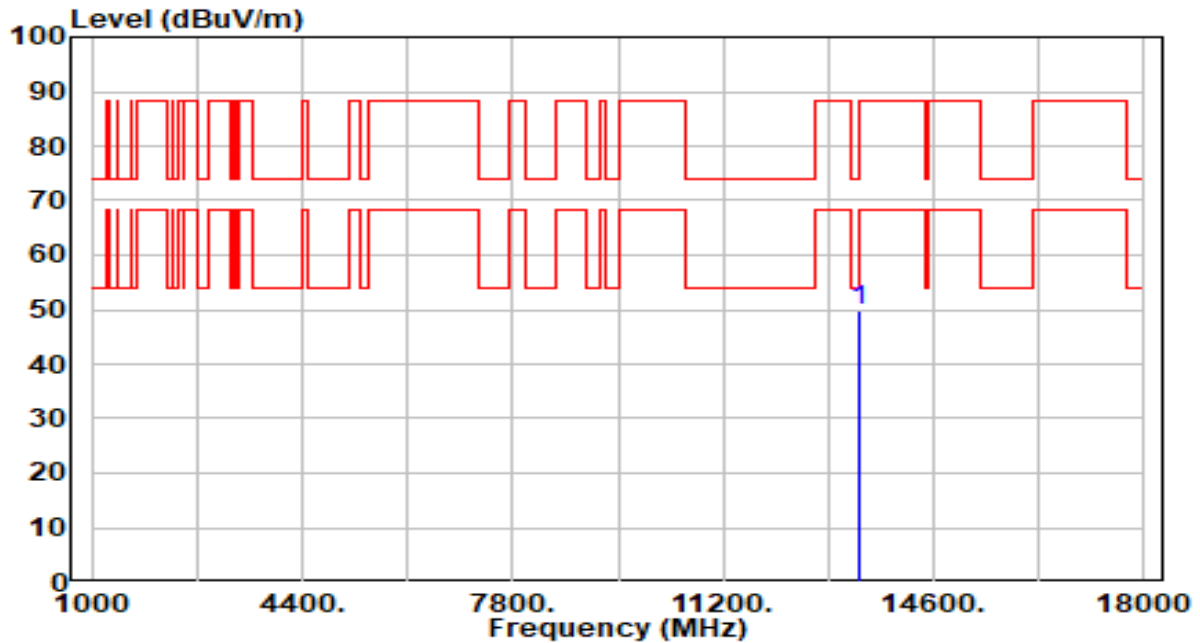

No	Frequency (MHz)	Reading (dBuV)	C.F (dB/m)	Measurement (dBuV/m)	Margin (dB)	Limit (dBuV/m)	Height (cm)	Angle (deg)	Remark (QP/PK/AV)
1	*	42.85	6.82	49.66	-24.34	74.00	200	131	Peak

Note:

- "*", means this data is the worst emission level.
- C.F (Correction Factor) = Antenna Factor (dB/m)+ Cable Loss (dB) – Preamplifier(dB).
- Measurement (dBuV/m) = Reading(dBuV) + C.F (Correction Factor).
- The emission levels of other frequencies are very lower than the limit and not show in test report.

EUT	BE11000 Tri-Band Wi-Fi 7 Gaming Router	Date of Test	2024-01-16
Factor	DRH18-E	Temp. / Humidity	21°C /63%
Polarity	Horizontal	Site / Test Engineer	AC2 / Marvin
Test Mode	802.11ax-20MHz_TX_Band7_CH 181_ANT 0+1 Nss2	Test Voltage	AC 120V/60Hz

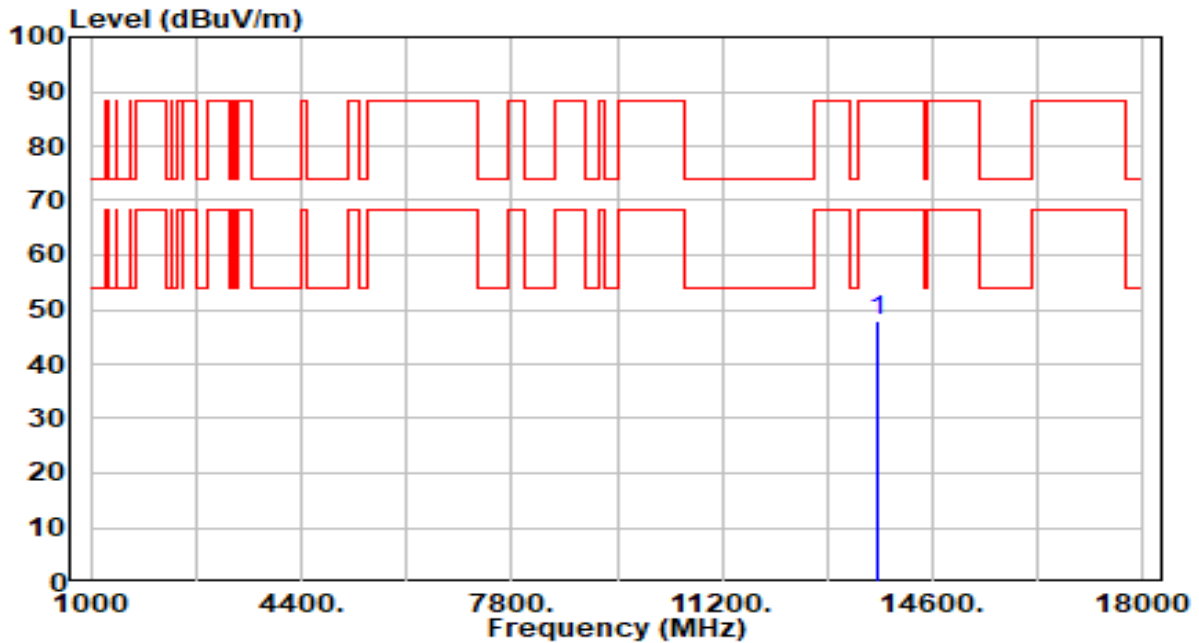

No	Frequency (MHz)	Reading (dBuV)	C.F (dB/m)	Measurement (dBuV/m)	Margin (dB)	Limit (dBuV/m)	Height (cm)	Angle (deg)	Remark (QP/PK/AV)
1	*	41.56	6.53	48.09	-40.11	88.20	200	72	Peak

Note:

1. " *", means this data is the worst emission level.
2. C.F (Correction Factor) = Antenna Factor (dB/m)+ Cable Loss (dB) – Preamplifier(dB).
3. Measurement (dBuV/m) = Reading(dBuV) + C.F (Correction Factor).
4. The emission levels of other frequencies are very lower than the limit and not show in test report.

EUT	BE11000 Tri-Band Wi-Fi 7 Gaming Router	Date of Test	2024-01-16
Factor	DRH18-E	Temp. / Humidity	21°C /63%
Polarity	Vertical	Site / Test Engineer	AC2 / Marvin
Test Mode	802.11ax-20MHz_TX_Band7_CH 181_ANT 0+1 Nss2	Test Voltage	AC 120V/60Hz

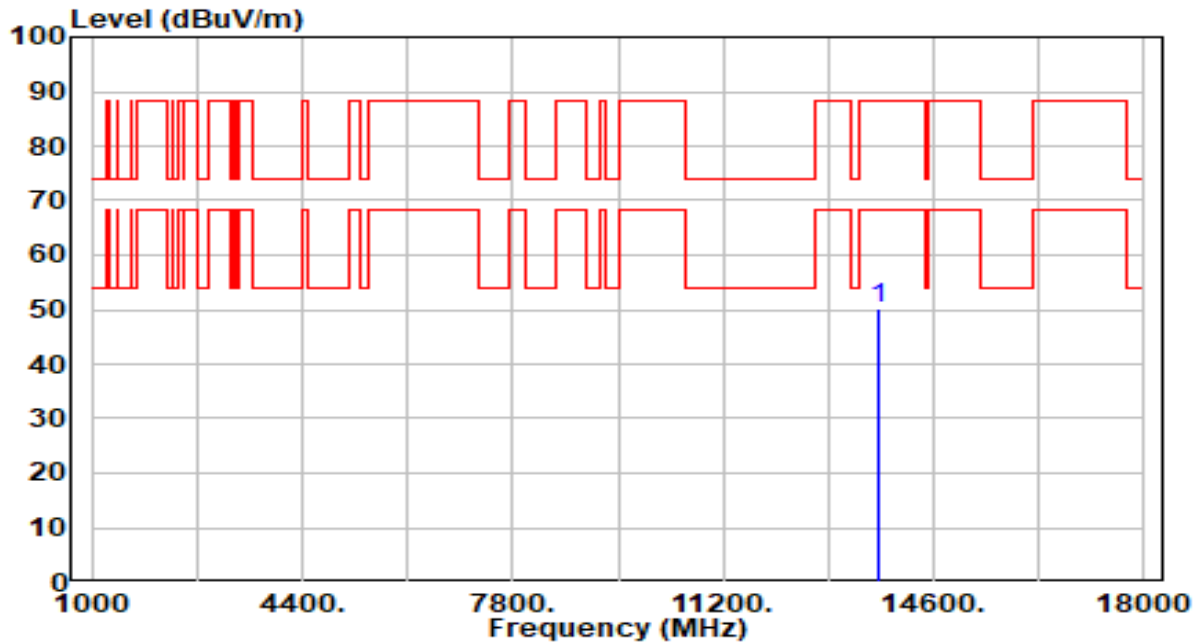

No	Frequency (MHz)	Reading (dBuV)	C.F (dB/m)	Measurement (dBuV/m)	Margin (dB)	Limit (dBuV/m)	Height (cm)	Angle (deg)	Remark (QP/PK/AV)
1	* 13710.000	43.57	6.53	50.10	-38.10	88.20	200	132	Peak

Note:

- "*", means this data is the worst emission level.
- C.F (Correction Factor) = Antenna Factor (dB/m)+ Cable Loss (dB) – Preamplifier(dB).
- Measurement (dBuV/m) = Reading(dBuV) + C.F (Correction Factor).
- The emission levels of other frequencies are very lower than the limit and not show in test report.

EUT	BE11000 Tri-Band Wi-Fi 7 Gaming Router	Date of Test	2024-01-16
Factor	DRH18-E	Temp. / Humidity	21°C /63%
Polarity	Horizontal	Site / Test Engineer	AC2 / Marvin
Test Mode	802.11ax-20MHz_TX_Band7_CH 185_ANT 0+1 Nss2	Test Voltage	AC 120V/60Hz

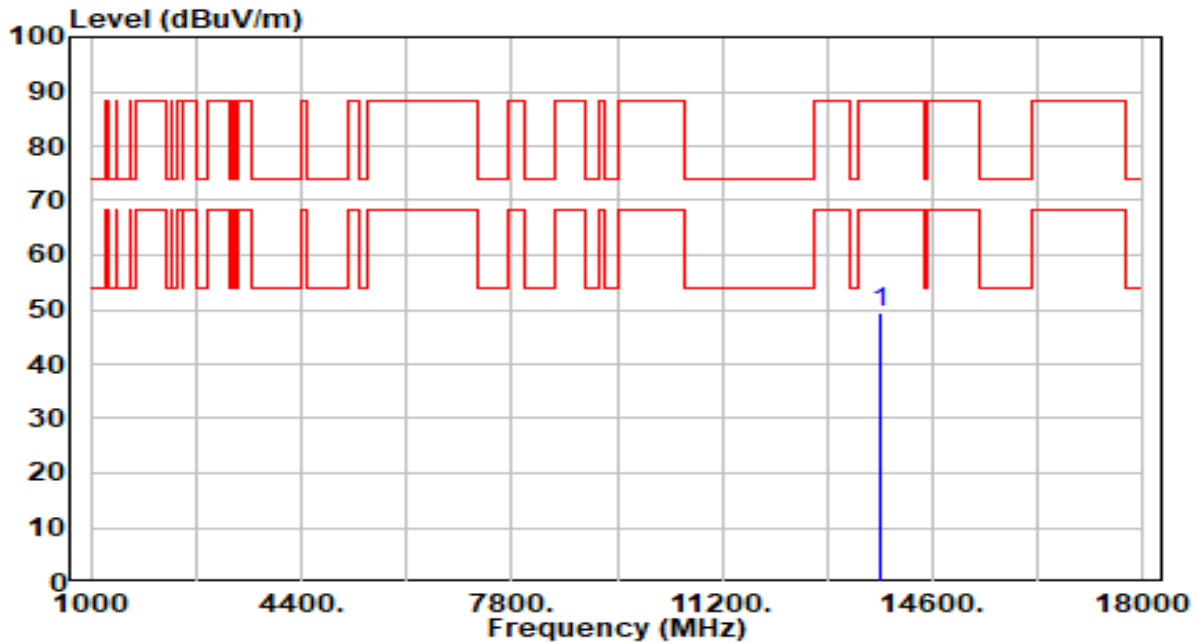

No	Frequency (MHz)	Reading (dBuV)	C.F (dB/m)	Measurement (dBuV/m)	Margin (dB)	Limit (dBuV/m)	Height (cm)	Angle (deg)	Remark (QP/PK/AV)
1	* 13750.000	42.76	6.53	49.28	-38.92	88.20	200	156	Peak

Note:

1. " *", means this data is the worst emission level.
2. C.F (Correction Factor) = Antenna Factor (dB/m)+ Cable Loss (dB) – Preamplifier(dB).
3. Measurement (dBuV/m) = Reading(dBuV) + C.F (Correction Factor).
4. The emission levels of other frequencies are very lower than the limit and not show in test report.

EUT	BE11000 Tri-Band Wi-Fi 7 Gaming Router	Date of Test	2024-01-16
Factor	DRH18-E	Temp. / Humidity	21°C /63%
Polarity	Vertical	Site / Test Engineer	AC2 / Marvin
Test Mode	802.11ax-20MHz_TX_Band7_CH 185_ANT 0+1 Nss2	Test Voltage	AC 120V/60Hz

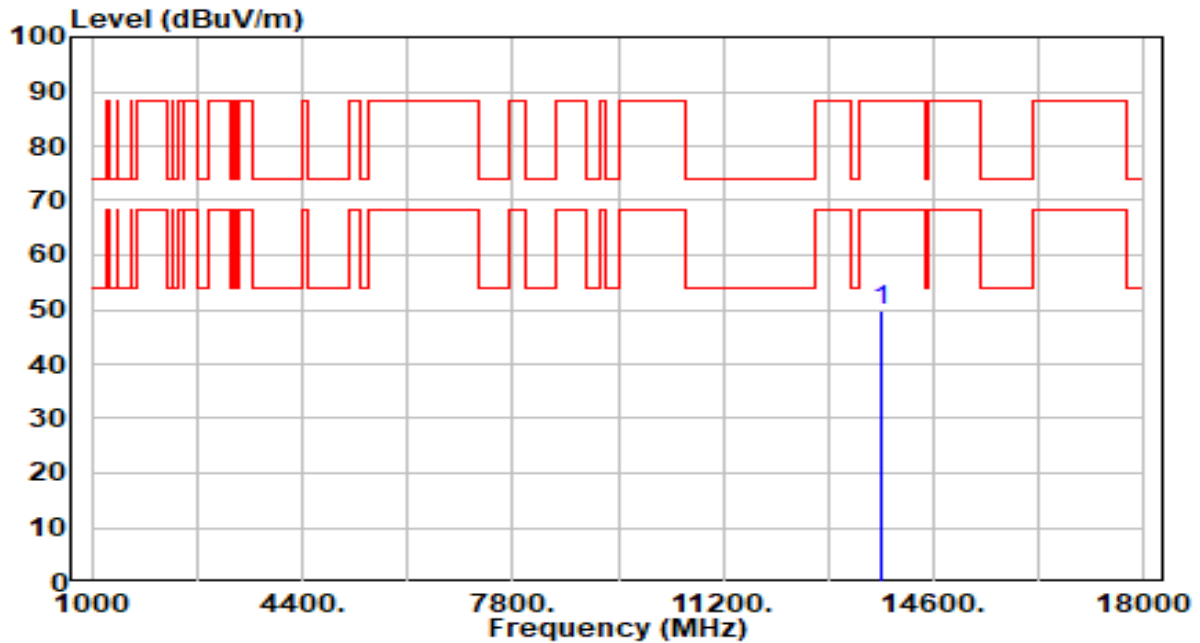

No	Frequency (MHz)	Reading (dBuV)	C.F (dB/m)	Measurement (dBuV/m)	Margin (dB)	Limit (dBuV/m)	Height (cm)	Angle (deg)	Remark (QP/PK/AV)
1	* 13750.000	43.25	6.53	49.77	-38.43	88.20	200	210	Peak

Note:

- "*", means this data is the worst emission level.
- C.F (Correction Factor) = Antenna Factor (dB/m)+ Cable Loss (dB) – Preamplifier(dB).
- Measurement (dBuV/m) = Reading(dBuV) + C.F (Correction Factor).
- The emission levels of other frequencies are very lower than the limit and not show in test report.

EUT	BE11000 Tri-Band Wi-Fi 7 Gaming Router	Date of Test	2024-01-16
Factor	DRH18-E	Temp. / Humidity	21°C /63%
Polarity	Horizontal	Site / Test Engineer	AC2 / Marvin
Test Mode	802.11ax-20MHz_TX_Band8_CH 189_ANT 0+1 Nss2	Test Voltage	AC 120V/60Hz

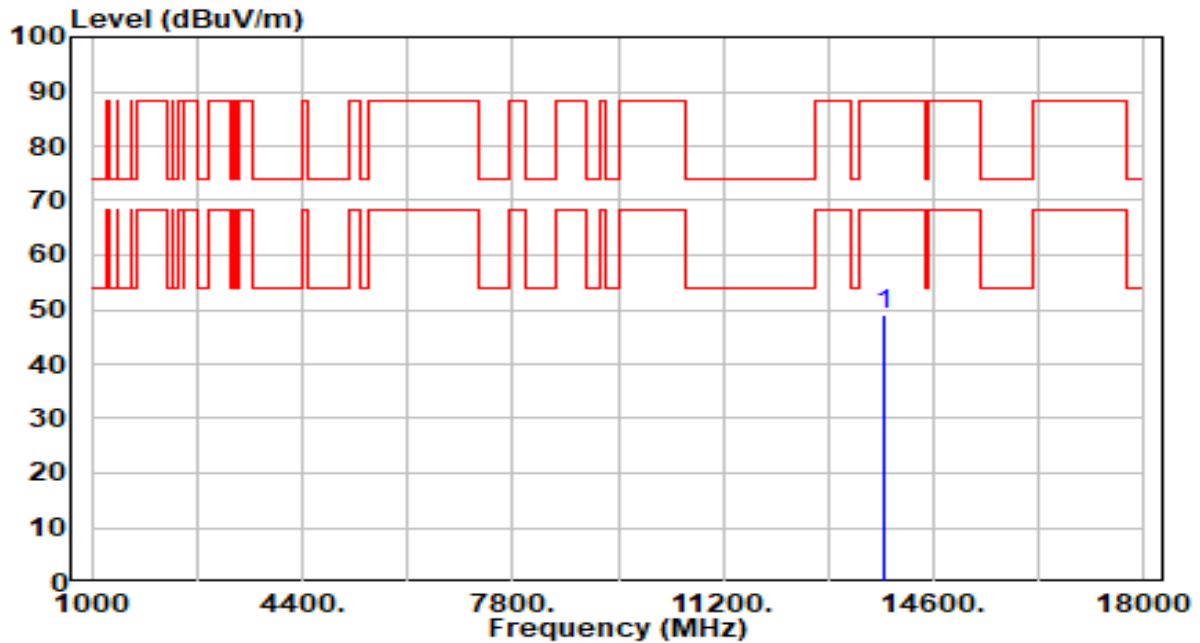

No	Frequency (MHz)	Reading (dBuV)	C.F (dB/m)	Measurement (dBuV/m)	Margin (dB)	Limit (dBuV/m)	Height (cm)	Angle (deg)	Remark (QP/PK/AV)
1	*	42.67	6.52	49.19	-39.01	88.20	200	45	Peak

Note:

- "*", means this data is the worst emission level.
- C.F (Correction Factor) = Antenna Factor (dB/m)+ Cable Loss (dB) – Preamplifier(dB).
- Measurement (dBuV/m) = Reading(dBuV) + C.F (Correction Factor).
- The emission levels of other frequencies are very lower than the limit and not show in test report.

EUT	BE11000 Tri-Band Wi-Fi 7 Gaming Router	Date of Test	2024-01-16
Factor	DRH18-E	Temp. / Humidity	21°C /63%
Polarity	Vertical	Site / Test Engineer	AC2 / Marvin
Test Mode	802.11ax-20MHz_TX_Band8_CH 189_ANT 0+1 Nss2	Test Voltage	AC 120V/60Hz

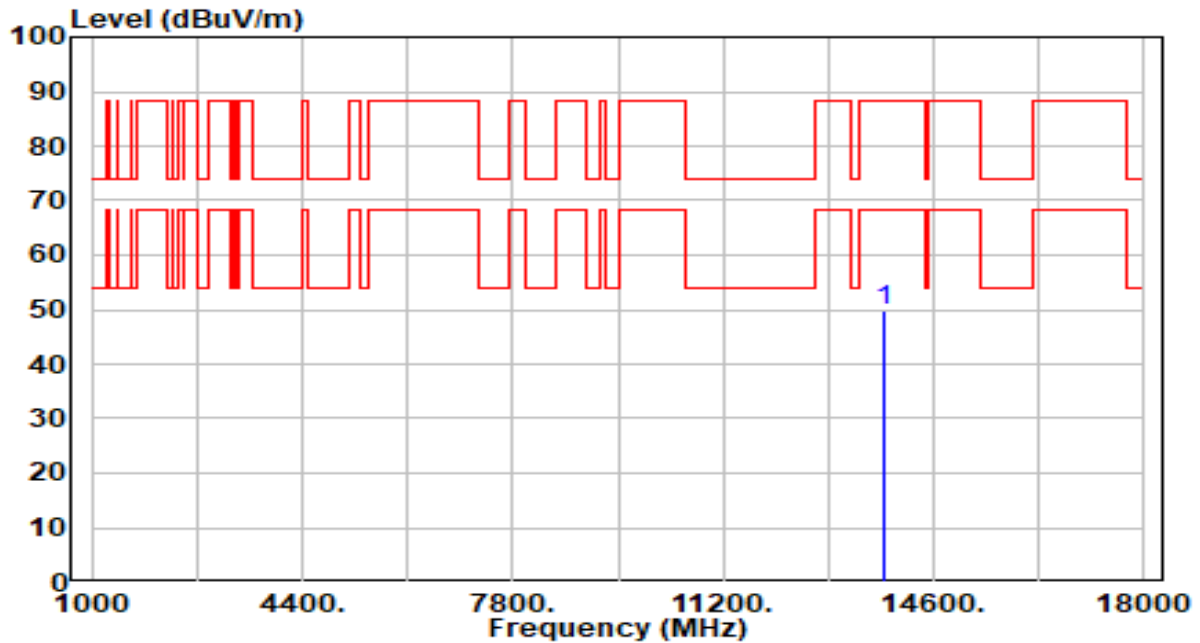

No	Frequency (MHz)	Reading (dBuV)	C.F (dB/m)	Measurement (dBuV/m)	Margin (dB)	Limit (dBuV/m)	Height (cm)	Angle (deg)	Remark (QP/PK/AV)
1	* 13790.000	43.21	6.52	49.73	-38.47	88.20	200	144	Peak

Note:

- "*", means this data is the worst emission level.
- C.F (Correction Factor) = Antenna Factor (dB/m)+ Cable Loss (dB) – Preamplifier(dB).
- Measurement (dBuV/m) = Reading(dBuV) + C.F (Correction Factor).
- The emission levels of other frequencies are very lower than the limit and not show in test report.

EUT	BE11000 Tri-Band Wi-Fi 7 Gaming Router	Date of Test	2024-01-16
Factor	DRH18-E	Temp. / Humidity	21°C /63%
Polarity	Horizontal	Site / Test Engineer	AC2 / Marvin
Test Mode	802.11ax-20MHz_TX_Band8_CH 213_ANT 0+1 Nss2	Test Voltage	AC 120V/60Hz

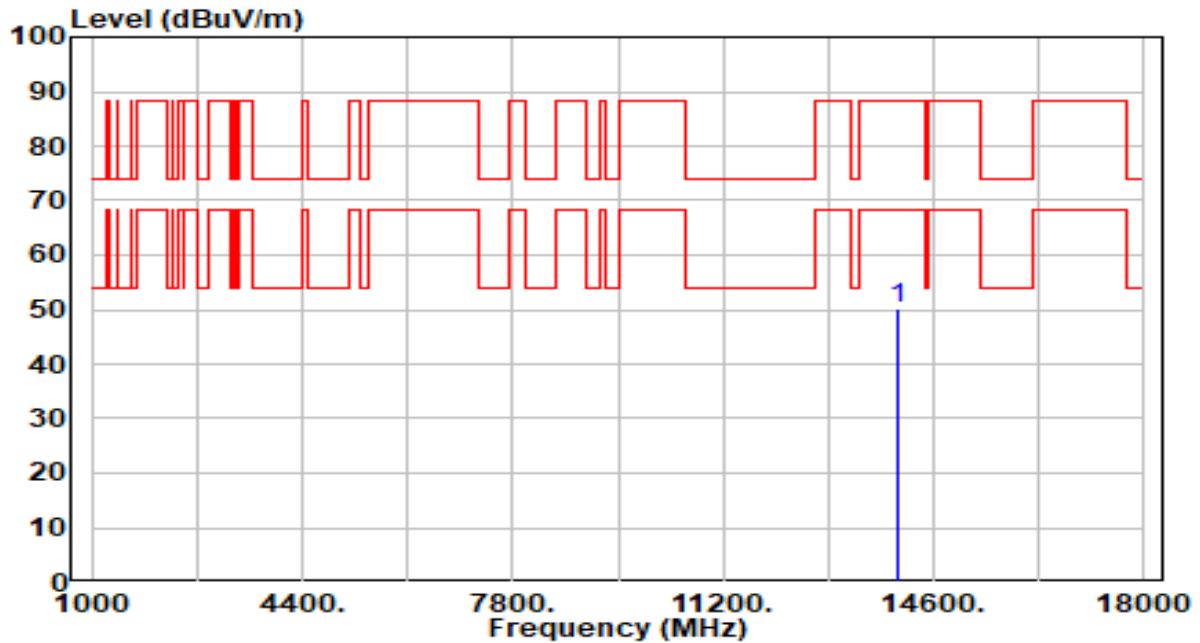

No	Frequency (MHz)	Reading (dBuV)	C.F (dB/m)	Measurement (dBuV/m)	Margin (dB)	Limit (dBuV/m)	Height (cm)	Angle (deg)	Remark (QP/PK/AV)
1	* 14030.000	43.50	6.63	50.12	-38.08	88.20	200	0	Peak

Note:

1. " *", means this data is the worst emission level.
2. C.F (Correction Factor) = Antenna Factor (dB/m)+ Cable Loss (dB) – Preamplifier(dB).
3. Measurement (dBuV/m) = Reading(dBuV) + C.F (Correction Factor).
4. The emission levels of other frequencies are very lower than the limit and not show in test report.

EUT	BE11000 Tri-Band Wi-Fi 7 Gaming Router	Date of Test	2024-01-16
Factor	DRH18-E	Temp. / Humidity	21°C /63%
Polarity	Vertical	Site / Test Engineer	AC2 / Marvin
Test Mode	802.11ax-20MHz_TX_Band8_CH 213_ANT 0+1 Nss2	Test Voltage	AC 120V/60Hz

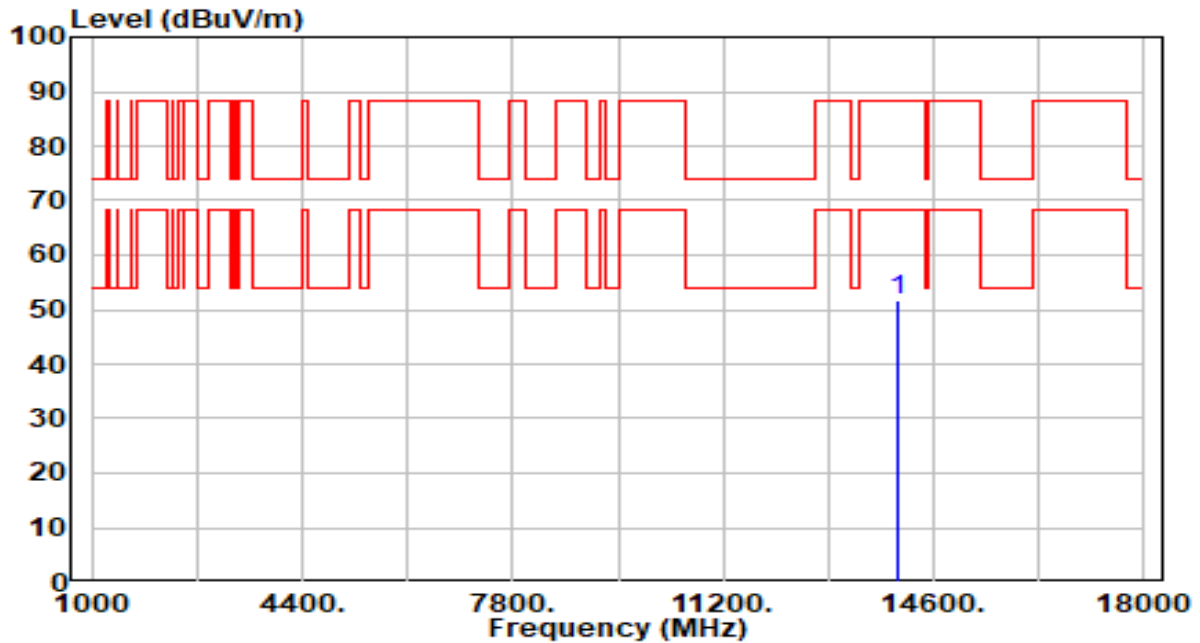

No	Frequency (MHz)	Reading (dBuV)	C.F (dB/m)	Measurement (dBuV/m)	Margin (dB)	Limit (dBuV/m)	Height (cm)	Angle (deg)	Remark (QP/PK/AV)
1	* 14030.000	44.94	6.63	51.57	-36.63	88.20	200	126	Peak

Note:

1. " *", means this data is the worst emission level.
2. C.F (Correction Factor) = Antenna Factor (dB/m)+ Cable Loss (dB) – Preamplifier(dB).
3. Measurement (dBuV/m) = Reading(dBuV) + C.F (Correction Factor).
4. The emission levels of other frequencies are very lower than the limit and not show in test report.

EUT	BE11000 Tri-Band Wi-Fi 7 Gaming Router	Date of Test	2024-01-16
Factor	DRH18-E	Temp. / Humidity	21°C /63%
Polarity	Horizontal	Site / Test Engineer	AC2 / Marvin
Test Mode	802.11ax-20MHz_TX_Band8_CH 229_ANT 0+1 Nss2	Test Voltage	AC 120V/60Hz

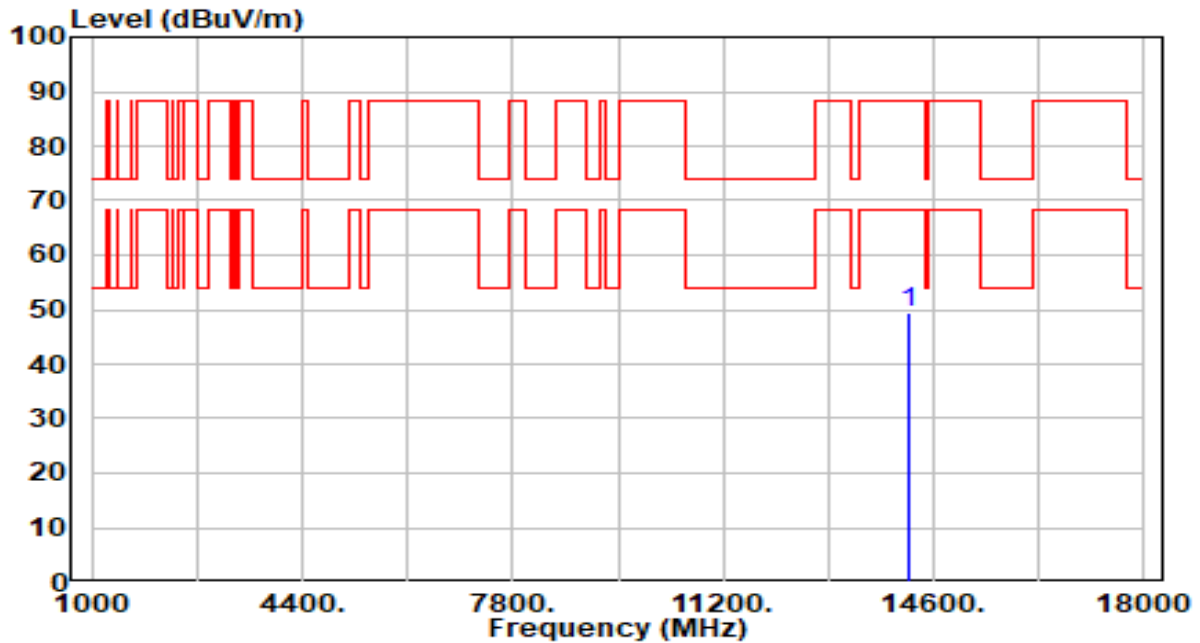

No	Frequency (MHz)	Reading (dBuV)	C.F (dB/m)	Measurement (dBuV/m)	Margin (dB)	Limit (dBuV/m)	Height (cm)	Angle (deg)	Remark (QP/PK/AV)
1	* 14190.000	42.83	6.66	49.48	-38.72	88.20	200	360	Peak

Note:

1. " *", means this data is the worst emission level.
2. C.F (Correction Factor) = Antenna Factor (dB/m)+ Cable Loss (dB) – Preamplifier(dB).
3. Measurement (dBuV/m) = Reading(dBuV) + C.F (Correction Factor).
4. The emission levels of other frequencies are very lower than the limit and not show in test report.

EUT	BE11000 Tri-Band Wi-Fi 7 Gaming Router	Date of Test	2024-01-16
Factor	DRH18-E	Temp. / Humidity	21°C /63%
Polarity	Vertical	Site / Test Engineer	AC2 / Marvin
Test Mode	802.11ax-20MHz_TX_Band8_CH 229_ANT 0+1 Nss2	Test Voltage	AC 120V/60Hz

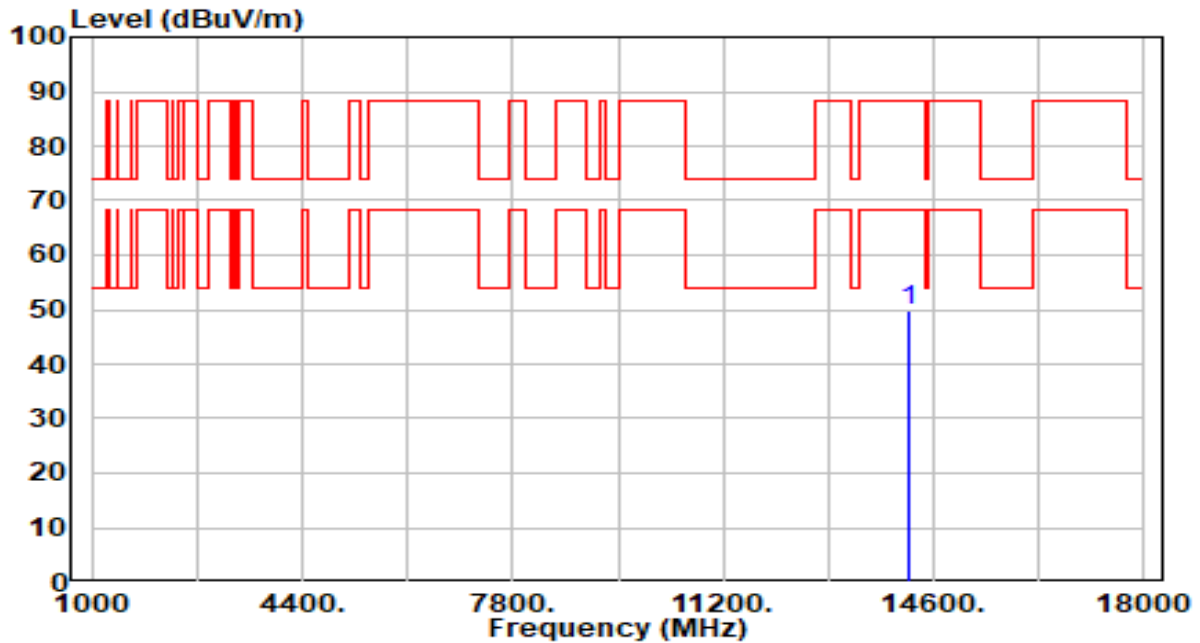

No	Frequency (MHz)	Reading (dBuV)	C.F (dB/m)	Measurement (dBuV/m)	Margin (dB)	Limit (dBuV/m)	Height (cm)	Angle (deg)	Remark (QP/PK/AV)
1	* 14190.000	43.33	6.66	49.99	-38.21	88.20	200	135	Peak

Note:

1. " *", means this data is the worst emission level.
2. C.F (Correction Factor) = Antenna Factor (dB/m)+ Cable Loss (dB) – Preamplifier(dB).
3. Measurement (dBuV/m) = Reading(dBuV) + C.F (Correction Factor).
4. The emission levels of other frequencies are very lower than the limit and not show in test report.

EUT	BE11000 Tri-Band Wi-Fi 7 Gaming Router	Date of Test	2024-01-16
Factor	DRH18-E	Temp. / Humidity	21°C /63%
Polarity	Horizontal	Site / Test Engineer	AC2 / Marvin
Test Mode	802.11ax-40MHz_TX_Band5_CH 3_ANT 0+1 Nss2	Test Voltage	AC 120V/60Hz

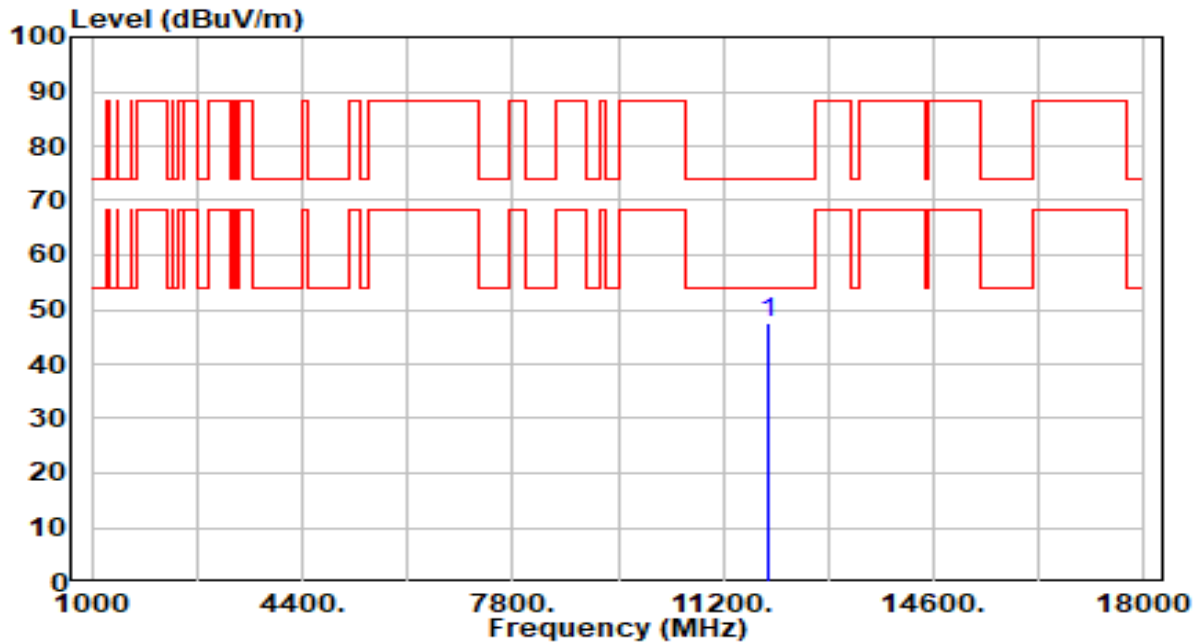

No	Frequency (MHz)	Reading (dBuV)	C.F (dB/m)	Measurement (dBuV/m)	Margin (dB)	Limit (dBuV/m)	Height (cm)	Angle (deg)	Remark (QP/PK/AV)
1	* 11930.000	42.03	5.41	47.45	-26.55	74.00	200	162	Peak

Note:

1. " *", means this data is the worst emission level.
2. C.F (Correction Factor) = Antenna Factor (dB/m)+ Cable Loss (dB) – Preamplifier(dB).
3. Measurement (dBuV/m) = Reading(dBuV) + C.F (Correction Factor).
4. The emission levels of other frequencies are very lower than the limit and not show in test report.

EUT	BE11000 Tri-Band Wi-Fi 7 Gaming Router	Date of Test	2024-01-16
Factor	DRH18-E	Temp. / Humidity	21°C /63%
Polarity	Vertical	Site / Test Engineer	AC2 / Marvin
Test Mode	802.11ax-40MHz_TX_Band5_CH 3_ANT 0+1 Nss2	Test Voltage	AC 120V/60Hz

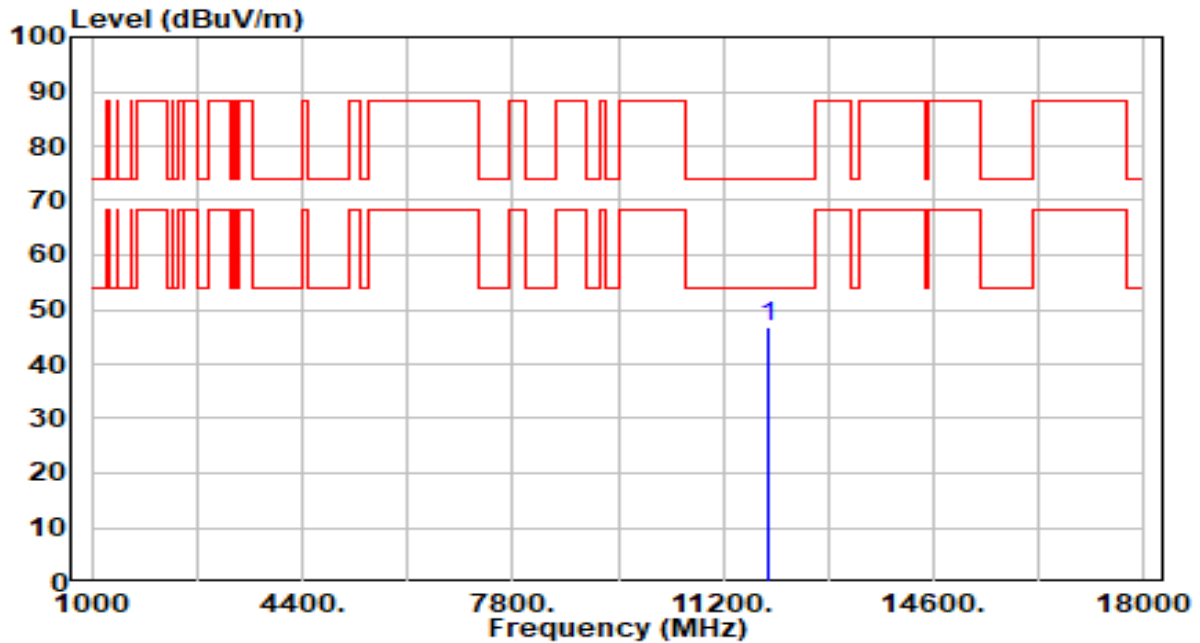

No	Frequency (MHz)	Reading (dBuV)	C.F (dB/m)	Measurement (dBuV/m)	Margin (dB)	Limit (dBuV/m)	Height (cm)	Angle (deg)	Remark (QP/PK/AV)
1	* 11930.000	41.53	5.41	46.95	-27.05	74.00	200	31	Peak

Note:

1. " *", means this data is the worst emission level.
2. C.F (Correction Factor) = Antenna Factor (dB/m)+ Cable Loss (dB) – Preamplifier(dB).
3. Measurement (dBuV/m) = Reading(dBuV) + C.F (Correction Factor).
4. The emission levels of other frequencies are very lower than the limit and not show in test report.

EUT	BE11000 Tri-Band Wi-Fi 7 Gaming Router	Date of Test	2024-01-16
Factor	DRH18-E	Temp. / Humidity	21°C /63%
Polarity	Horizontal	Site / Test Engineer	AC2 / Marvin
Test Mode	802.11ax-40MHz_TX_Band5_CH 43_ANT 0+1 Nss2	Test Voltage	AC 120V/60Hz

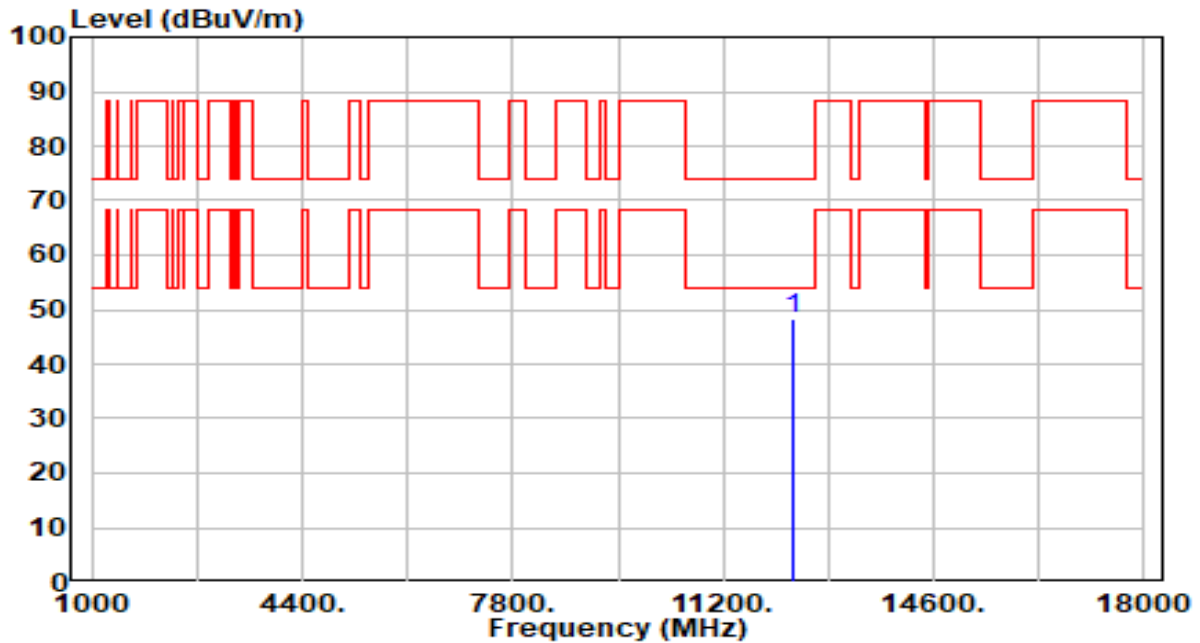

No	Frequency (MHz)	Reading (dBuV)	C.F (dB/m)	Measurement (dBuV/m)	Margin (dB)	Limit (dBuV/m)	Height (cm)	Angle (deg)	Remark (QP/PK/AV)
1	*	42.40	6.07	48.46	-25.54	74.00	200	327	Peak

Note:

- "*", means this data is the worst emission level.
- C.F (Correction Factor) = Antenna Factor (dB/m)+ Cable Loss (dB) – Preamplifier(dB).
- Measurement (dBuV/m) = Reading(dBuV) + C.F (Correction Factor).
- The emission levels of other frequencies are very lower than the limit and not show in test report.

EUT	BE11000 Tri-Band Wi-Fi 7 Gaming Router	Date of Test	2024-01-16
Factor	DRH18-E	Temp. / Humidity	21°C /63%
Polarity	Vertical	Site / Test Engineer	AC2 / Marvin
Test Mode	802.11ax-40MHz_TX_Band5_CH 43_ANT 0+1 Nss2	Test Voltage	AC 120V/60Hz

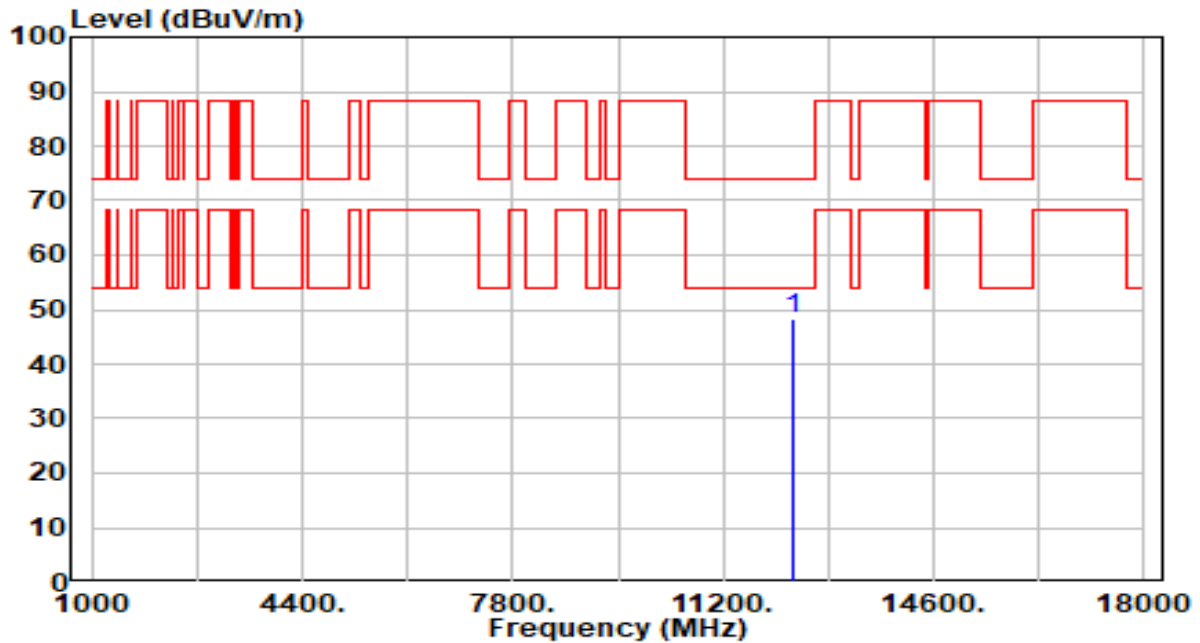

No	Frequency (MHz)	Reading (dBuV)	C.F (dB/m)	Measurement (dBuV/m)	Margin (dB)	Limit (dBuV/m)	Height (cm)	Angle (deg)	Remark (QP/PK/AV)
1	*	42.19	6.07	48.26	-25.74	74.00	200	360	Peak

Note:

- "*", means this data is the worst emission level.
- C.F (Correction Factor) = Antenna Factor (dB/m)+ Cable Loss (dB) – Preamplifier(dB).
- Measurement (dBuV/m) = Reading(dBuV) + C.F (Correction Factor).
- The emission levels of other frequencies are very lower than the limit and not show in test report.

EUT	BE11000 Tri-Band Wi-Fi 7 Gaming Router	Date of Test	2024-01-16
Factor	DRH18-E	Temp. / Humidity	21°C /63%
Polarity	Horizontal	Site / Test Engineer	AC2 / Marvin
Test Mode	802.11ax-40MHz_TX_Band5_CH 91_ANT 0+1 Nss2	Test Voltage	AC 120V/60Hz

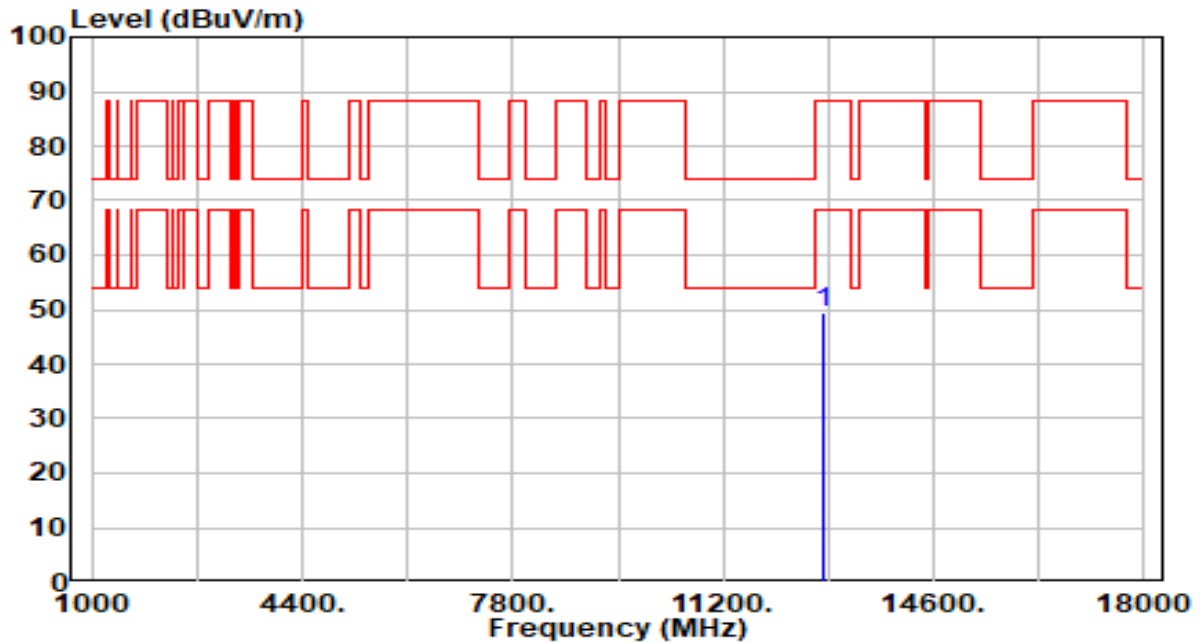

No	Frequency (MHz)	Reading (dBuV)	C.F (dB/m)	Measurement (dBuV/m)	Margin (dB)	Limit (dBuV/m)	Height (cm)	Angle (deg)	Remark (QP/PK/AV)
1	*	42.53	6.92	49.45	-38.75	88.20	200	140	Peak

Note:

- "*", means this data is the worst emission level.
- C.F (Correction Factor) = Antenna Factor (dB/m)+ Cable Loss (dB) – Preamplifier(dB).
- Measurement (dBuV/m) = Reading(dBuV) + C.F (Correction Factor).
- The emission levels of other frequencies are very lower than the limit and not show in test report.

EUT	BE11000 Tri-Band Wi-Fi 7 Gaming Router	Date of Test	2024-01-16
Factor	DRH18-E	Temp. / Humidity	21°C /63%
Polarity	Vertical	Site / Test Engineer	AC2 / Marvin
Test Mode	802.11ax-40MHz_TX_Band5_CH 91_ANT 0+1 Nss2	Test Voltage	AC 120V/60Hz

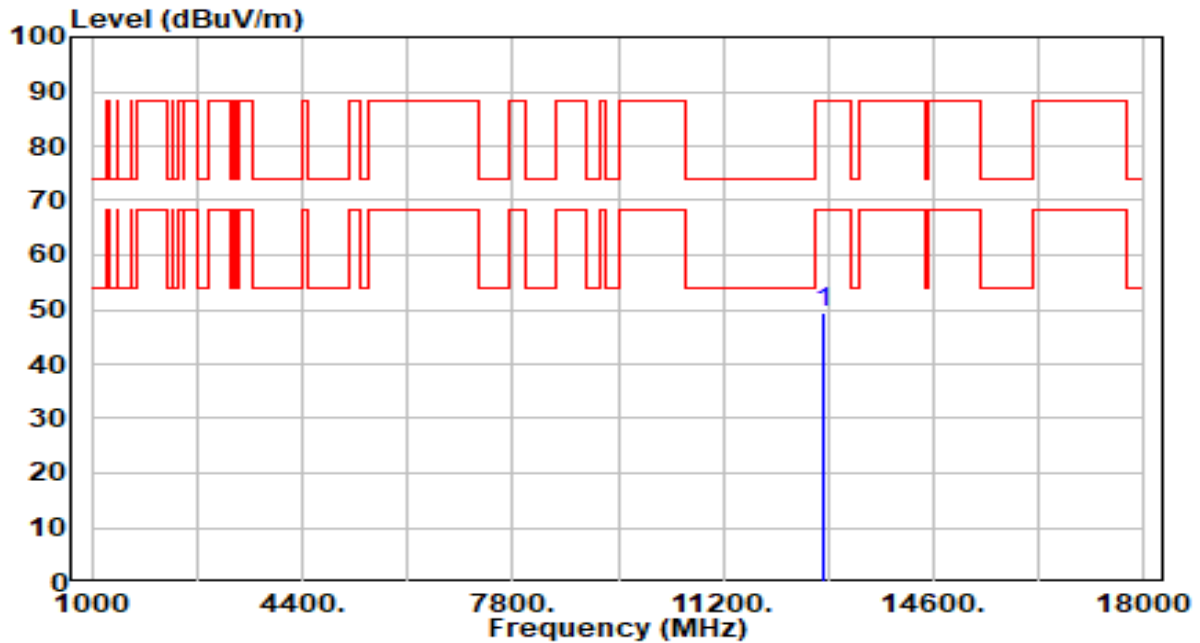

No	Frequency (MHz)	Reading (dBuV)	C.F (dB/m)	Measurement (dBuV/m)	Margin (dB)	Limit (dBuV/m)	Height (cm)	Angle (deg)	Remark (QP/PK/AV)
1	*	42.57	6.92	49.49	-38.71	88.20	200	196	Peak

Note:

- "*", means this data is the worst emission level.
- C.F (Correction Factor) = Antenna Factor (dB/m)+ Cable Loss (dB) – Preamplifier(dB).
- Measurement (dBuV/m) = Reading(dBuV) + C.F (Correction Factor).
- The emission levels of other frequencies are very lower than the limit and not show in test report.

EUT	BE11000 Tri-Band Wi-Fi 7 Gaming Router	Date of Test	2024-01-16
Factor	DRH18-E	Temp. / Humidity	21°C /63%
Polarity	Horizontal	Site / Test Engineer	AC2 / Marvin
Test Mode	802.11ax-40MHz_TX_Band6_CH 99_ANT 0+1 Nss2	Test Voltage	AC 120V/60Hz

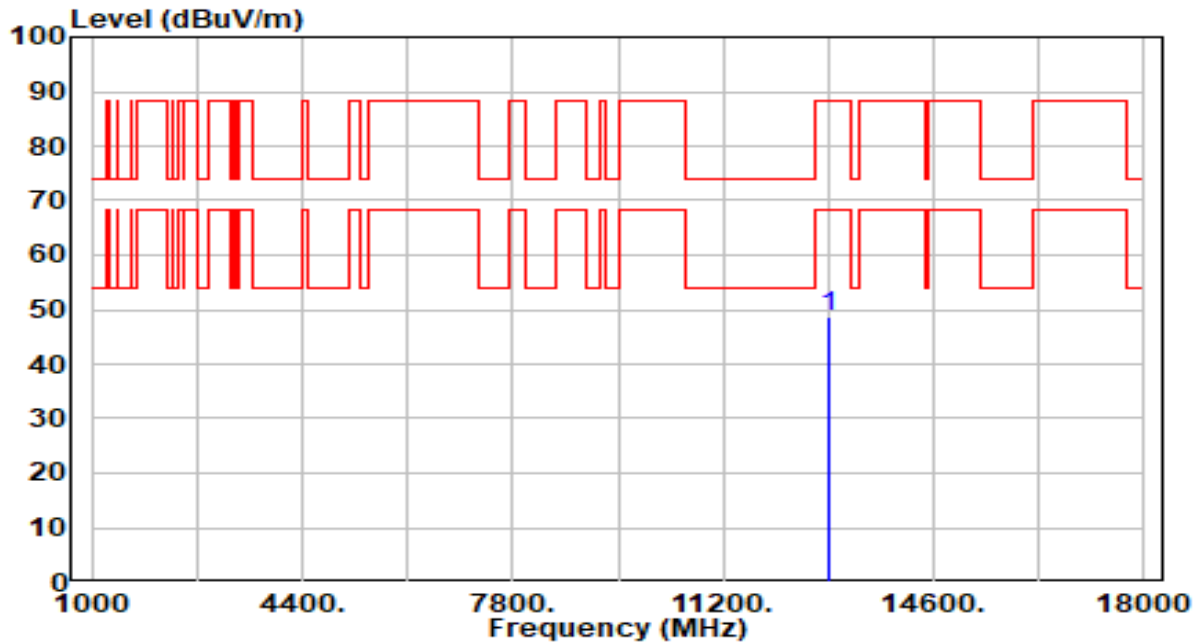

No	Frequency (MHz)	Reading (dBuV)	C.F (dB/m)	Measurement (dBuV/m)	Margin (dB)	Limit (dBuV/m)	Height (cm)	Angle (deg)	Remark (QP/PK/AV)
1	*	41.93	6.90	48.83	-39.37	88.20	0	0	Peak

Note:

1. " *", means this data is the worst emission level.
2. C.F (Correction Factor) = Antenna Factor (dB/m)+ Cable Loss (dB) – Preamplifier(dB).
3. Measurement (dBuV/m) = Reading(dBuV) + C.F (Correction Factor).
4. The emission levels of other frequencies are very lower than the limit and not show in test report.

EUT	BE11000 Tri-Band Wi-Fi 7 Gaming Router	Date of Test	2024-01-16
Factor	DRH18-E	Temp. / Humidity	21°C /63%
Polarity	Vertical	Site / Test Engineer	AC2 / Marvin
Test Mode	802.11ax-40MHz_TX_Band6_CH 99_ANT 0+1 Nss2	Test Voltage	AC 120V/60Hz

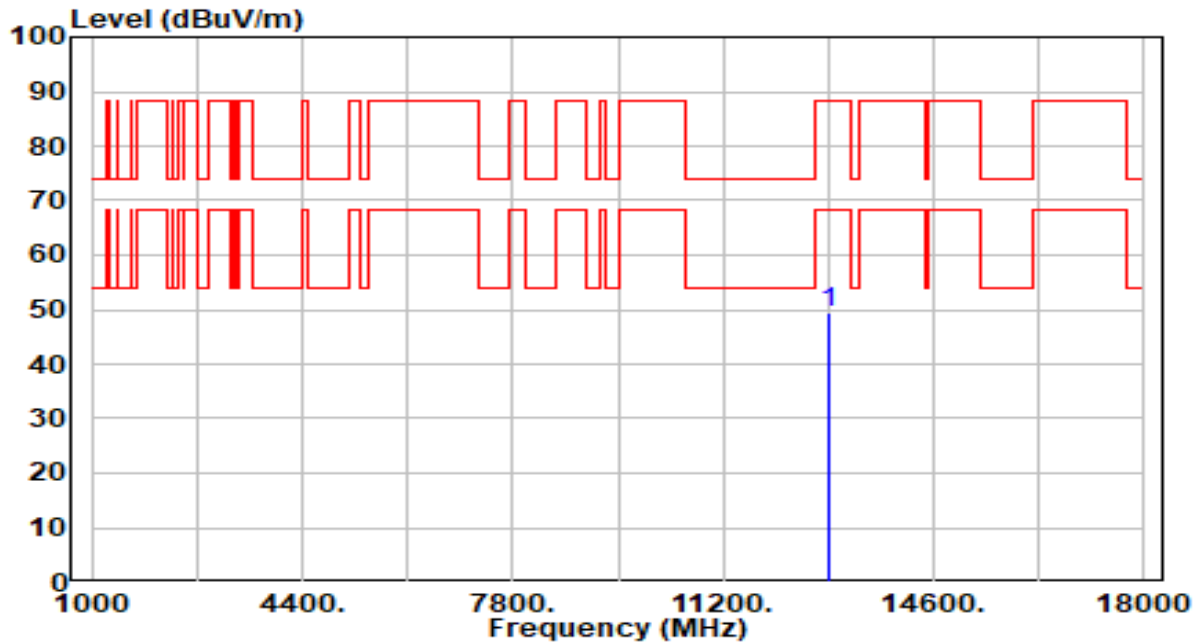

No	Frequency (MHz)	Reading (dBuV)	C.F (dB/m)	Measurement (dBuV/m)	Margin (dB)	Limit (dBuV/m)	Height (cm)	Angle (deg)	Remark (QP/PK/AV)
1	*	42.58	6.90	49.48	-38.72	88.20	200	12	Peak

Note:

1. " *", means this data is the worst emission level.
2. C.F (Correction Factor) = Antenna Factor (dB/m)+ Cable Loss (dB) – Preamplifier(dB).
3. Measurement (dBuV/m) = Reading(dBuV) + C.F (Correction Factor).
4. The emission levels of other frequencies are very lower than the limit and not show in test report.

EUT	BE11000 Tri-Band Wi-Fi 7 Gaming Router	Date of Test	2024-01-16
Factor	DRH18-E	Temp. / Humidity	21°C /63%
Polarity	Horizontal	Site / Test Engineer	AC2 / Marvin
Test Mode	802.11ax-40MHz_TX_Band6_CH 107_ANT 0+1 Nss2	Test Voltage	AC 120V/60Hz

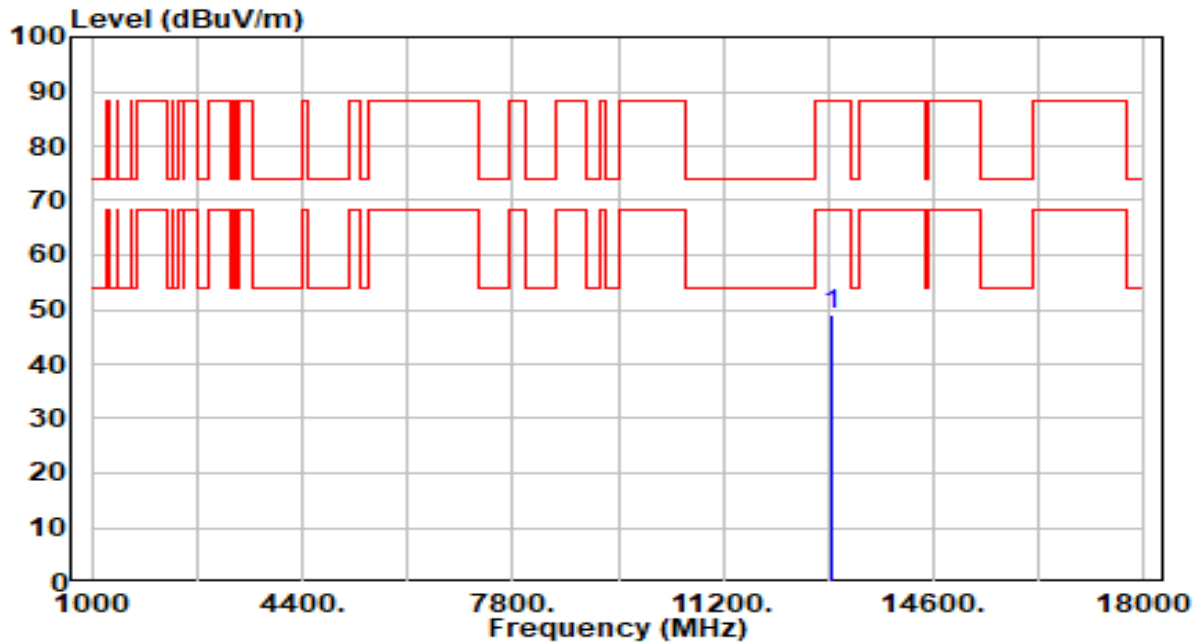

No	Frequency (MHz)	Reading (dBuV)	C.F (dB/m)	Measurement (dBuV/m)	Margin (dB)	Limit (dBuV/m)	Height (cm)	Angle (deg)	Remark (QP/PK/AV)
1	*	42.33	6.88	49.21	-38.99	88.20	200	360	Peak

Note:

1. " *", means this data is the worst emission level.
2. C.F (Correction Factor) = Antenna Factor (dB/m)+ Cable Loss (dB) – Preamplifier(dB).
3. Measurement (dBuV/m) = Reading(dBuV) + C.F (Correction Factor).
4. The emission levels of other frequencies are very lower than the limit and not show in test report.

EUT	BE11000 Tri-Band Wi-Fi 7 Gaming Router	Date of Test	2024-01-16
Factor	DRH18-E	Temp. / Humidity	21°C /63%
Polarity	Vertical	Site / Test Engineer	AC2 / Marvin
Test Mode	802.11ax-40MHz_TX_Band6_CH 107_ANT 0+1 Nss2	Test Voltage	AC 120V/60Hz

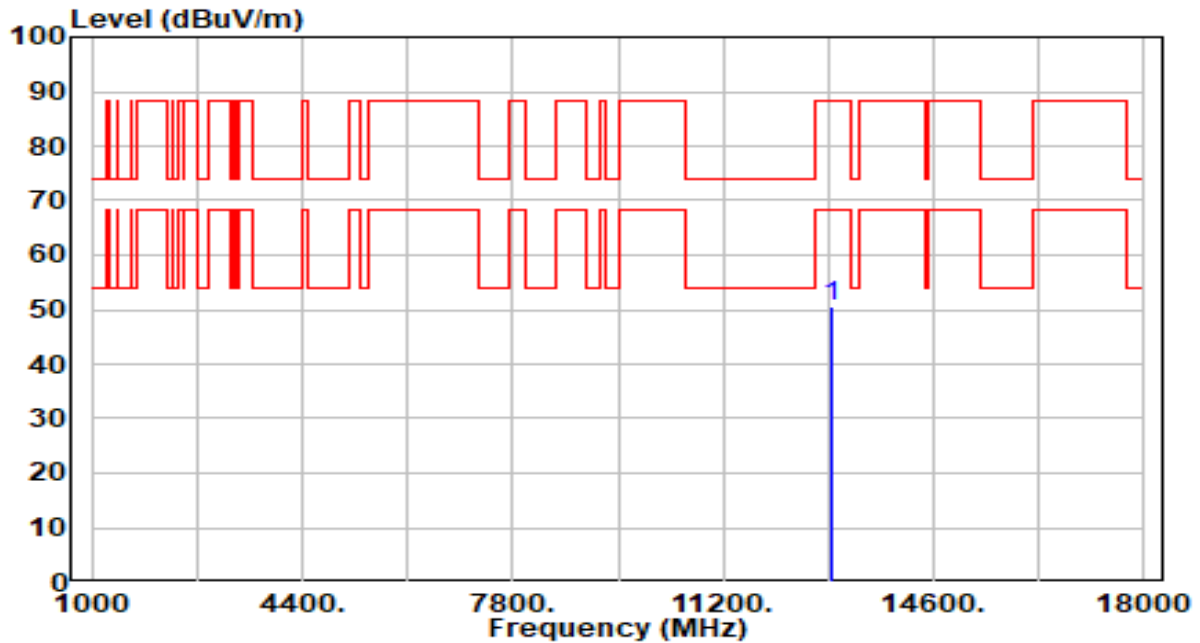

No	Frequency (MHz)	Reading (dBuV)	C.F (dB/m)	Measurement (dBuV/m)	Margin (dB)	Limit (dBuV/m)	Height (cm)	Angle (deg)	Remark (QP/PK/AV)
1	*	43.61	6.88	50.49	-37.71	88.20	200	161	Peak

Note:

- "*", means this data is the worst emission level.
- C.F (Correction Factor) = Antenna Factor (dB/m)+ Cable Loss (dB) – Preamplifier(dB).
- Measurement (dBuV/m) = Reading(dBuV) + C.F (Correction Factor).
- The emission levels of other frequencies are very lower than the limit and not show in test report.

EUT	BE11000 Tri-Band Wi-Fi 7 Gaming Router	Date of Test	2024-01-16
Factor	DRH18-E	Temp. / Humidity	21°C /63%
Polarity	Horizontal	Site / Test Engineer	AC2 / Marvin
Test Mode	802.11ax-40MHz_TX_Band6_CH 115_ANT 0+1 Nss2	Test Voltage	AC 120V/60Hz

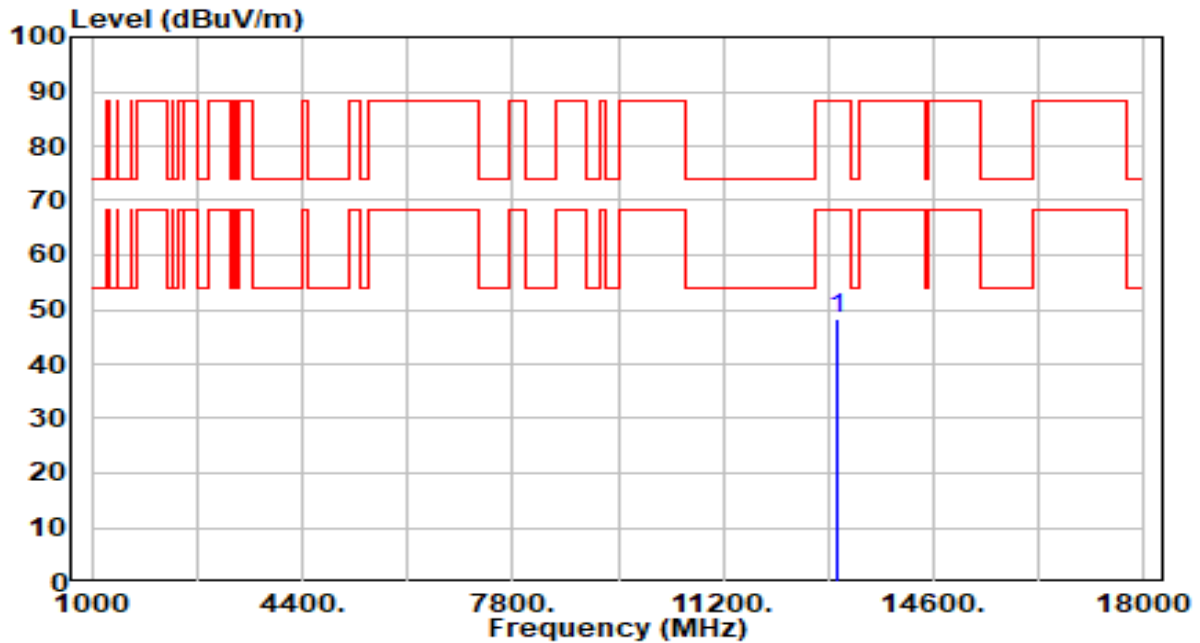

No	Frequency (MHz)	Reading (dBuV)	C.F (dB/m)	Measurement (dBuV/m)	Margin (dB)	Limit (dBuV/m)	Height (cm)	Angle (deg)	Remark (QP/PK/AV)
1	* 13050.000	41.38	6.85	48.23	-39.97	88.20	200	261	Peak

Note:

1. " *", means this data is the worst emission level.
2. C.F (Correction Factor) = Antenna Factor (dB/m)+ Cable Loss (dB) – Preamplifier(dB).
3. Measurement (dBuV/m) = Reading(dBuV) + C.F (Correction Factor).
4. The emission levels of other frequencies are very lower than the limit and not show in test report.

EUT	BE11000 Tri-Band Wi-Fi 7 Gaming Router	Date of Test	2024-01-16
Factor	DRH18-E	Temp. / Humidity	21°C /63%
Polarity	Vertical	Site / Test Engineer	AC2 / Marvin
Test Mode	802.11ax-40MHz_TX_Band6_CH 115_ANT 0+1 Nss2	Test Voltage	AC 120V/60Hz

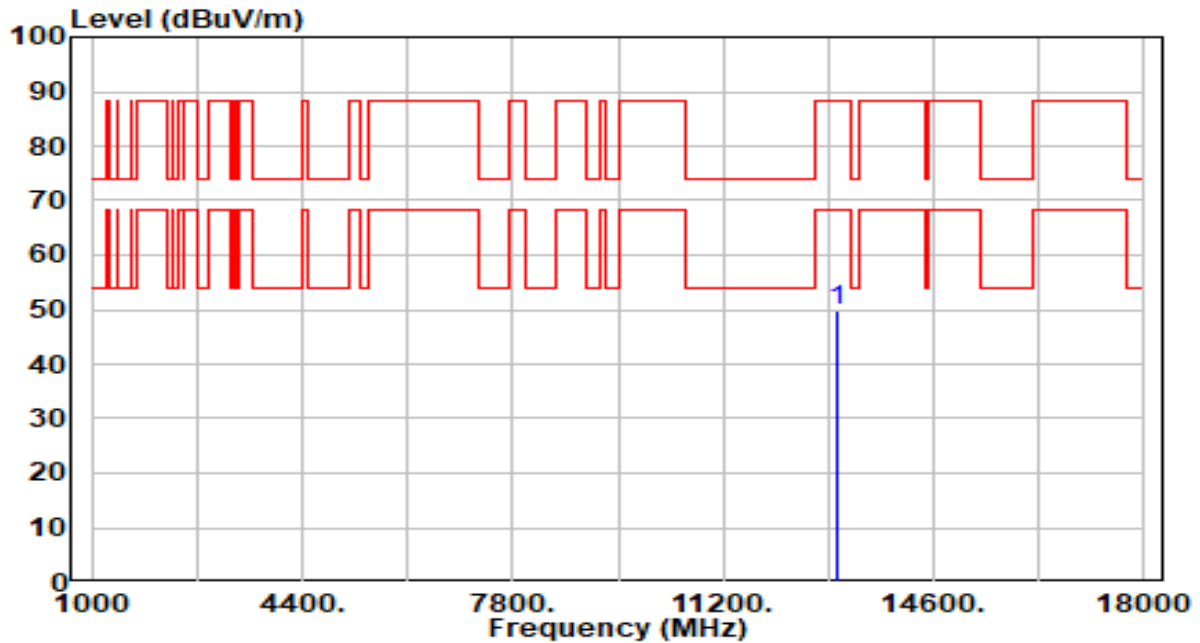

No	Frequency (MHz)	Reading (dBuV)	C.F (dB/m)	Measurement (dBuV/m)	Margin (dB)	Limit (dBuV/m)	Height (cm)	Angle (deg)	Remark (QP/PK/AV)
1	*	43.07	6.85	49.92	-38.28	88.20	200	143	Peak

Note:

- "*", means this data is the worst emission level.
- C.F (Correction Factor) = Antenna Factor (dB/m)+ Cable Loss (dB) – Preamplifier(dB).
- Measurement (dBuV/m) = Reading(dBuV) + C.F (Correction Factor).
- The emission levels of other frequencies are very lower than the limit and not show in test report.

EUT	BE11000 Tri-Band Wi-Fi 7 Gaming Router	Date of Test	2024-01-16
Factor	DRH18-E	Temp. / Humidity	21°C /63%
Polarity	Horizontal	Site / Test Engineer	AC2 / Marvin
Test Mode	802.11ax-40MHz_TX_Band7_CH 123_ANT 0+1 Nss2	Test Voltage	AC 120V/60Hz

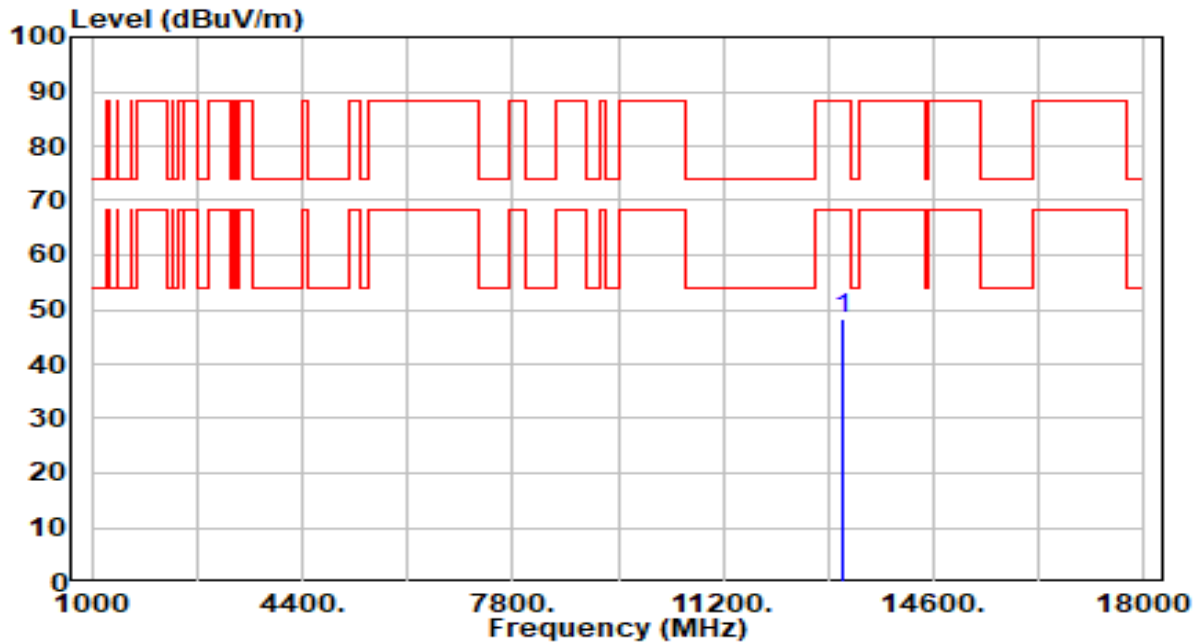

No	Frequency (MHz)	Reading (dBuV)	C.F (dB/m)	Measurement (dBuV/m)	Margin (dB)	Limit (dBuV/m)	Height (cm)	Angle (deg)	Remark (QP/PK/AV)
1	*	41.39	6.82	48.21	-39.99	88.20	200	126	Peak

Note:

- "*", means this data is the worst emission level.
- C.F (Correction Factor) = Antenna Factor (dB/m)+ Cable Loss (dB) – Preamplifier(dB).
- Measurement (dBuV/m) = Reading(dBuV) + C.F (Correction Factor).
- The emission levels of other frequencies are very lower than the limit and not show in test report.

EUT	BE11000 Tri-Band Wi-Fi 7 Gaming Router	Date of Test	2024-01-16
Factor	DRH18-E	Temp. / Humidity	21°C /63%
Polarity	Vertical	Site / Test Engineer	AC2 / Marvin
Test Mode	802.11ax-40MHz_TX_Band7_CH 123_ANT 0+1 Nss2	Test Voltage	AC 120V/60Hz

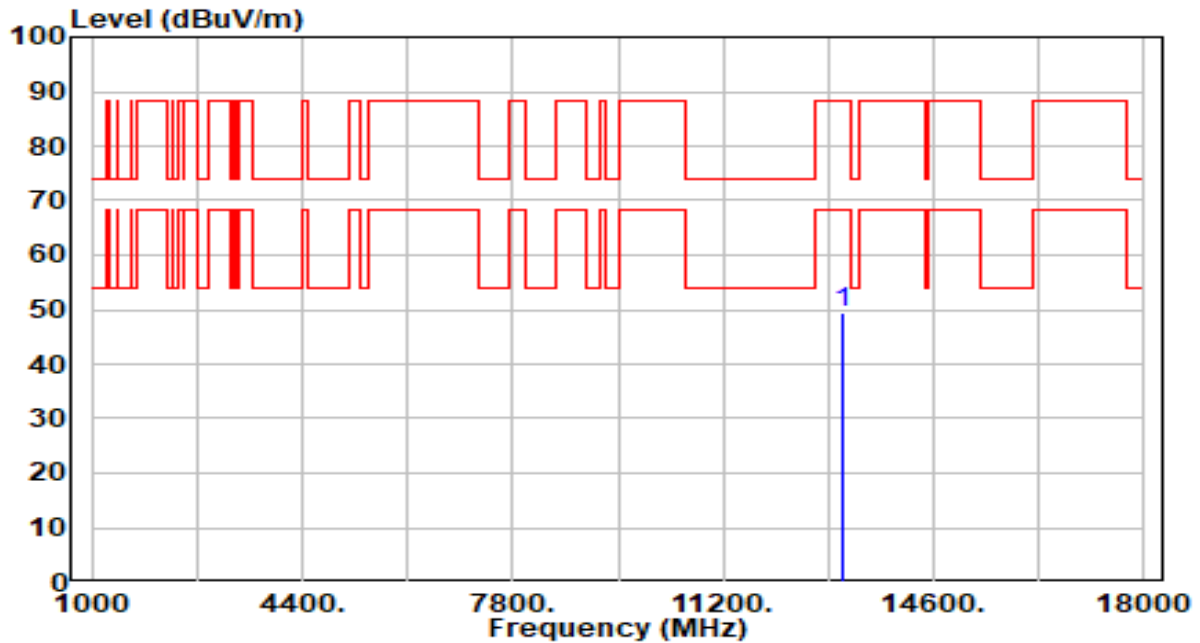

No	Frequency (MHz)	Reading (dBuV)	C.F (dB/m)	Measurement (dBuV/m)	Margin (dB)	Limit (dBuV/m)	Height (cm)	Angle (deg)	Remark (QP/PK/AV)
1	*	42.61	6.82	49.43	-38.77	88.20	200	150	Peak

Note:

1. " *", means this data is the worst emission level.
2. C.F (Correction Factor) = Antenna Factor (dB/m)+ Cable Loss (dB) – Preamplifier(dB).
3. Measurement (dBuV/m) = Reading(dBuV) + C.F (Correction Factor).
4. The emission levels of other frequencies are very lower than the limit and not show in test report.

EUT	BE11000 Tri-Band Wi-Fi 7 Gaming Router	Date of Test	2024-01-16
Factor	DRH18-E	Temp. / Humidity	21°C /63%
Polarity	Horizontal	Site / Test Engineer	AC2 / Marvin
Test Mode	802.11ax-40MHz_TX_Band7_CH 147_ANT 0+1 Nss2	Test Voltage	AC 120V/60Hz

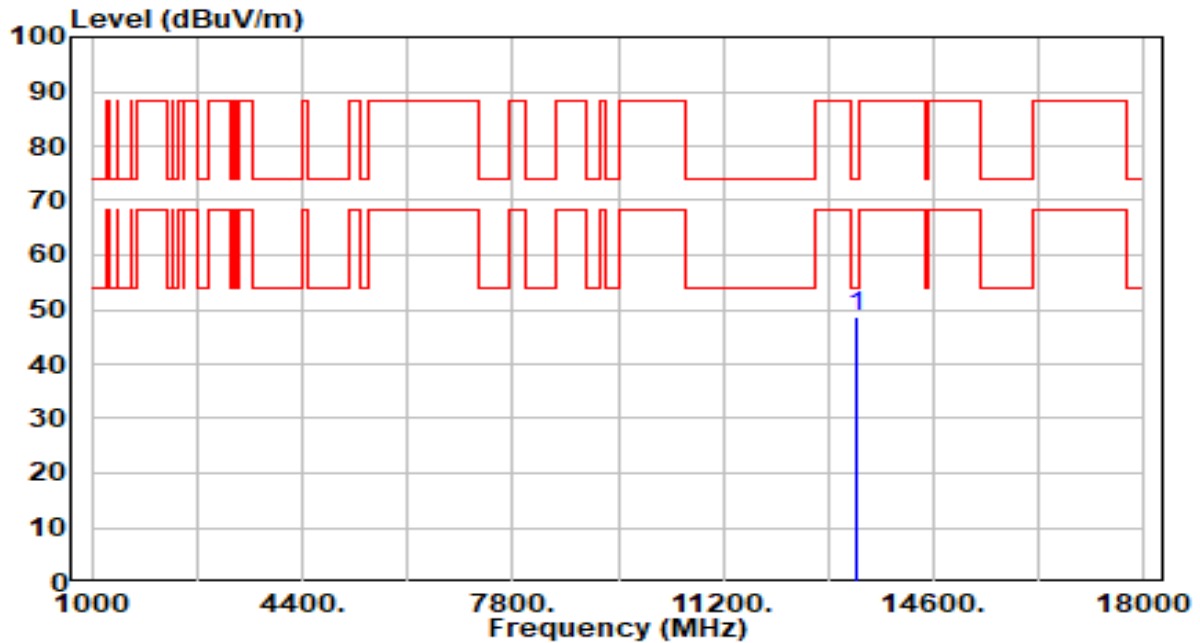

No	Frequency (MHz)	Reading (dBuV)	C.F (dB/m)	Measurement (dBuV/m)	Margin (dB)	Limit (dBuV/m)	Height (cm)	Angle (deg)	Remark (QP/PK/AV)
1	*	41.84	6.81	48.66	-25.34	74.00	200	201	Peak

Note:

1. " *", means this data is the worst emission level.
2. C.F (Correction Factor) = Antenna Factor (dB/m)+ Cable Loss (dB) – Preamplifier(dB).
3. Measurement (dBuV/m) = Reading(dBuV) + C.F (Correction Factor).
4. The emission levels of other frequencies are very lower than the limit and not show in test report.

EUT	BE11000 Tri-Band Wi-Fi 7 Gaming Router	Date of Test	2024-01-16
Factor	DRH18-E	Temp. / Humidity	21°C /63%
Polarity	Vertical	Site / Test Engineer	AC2 / Marvin
Test Mode	802.11ax-40MHz_TX_Band7_CH 147_ANT 0+1 Nss2	Test Voltage	AC 120V/60Hz

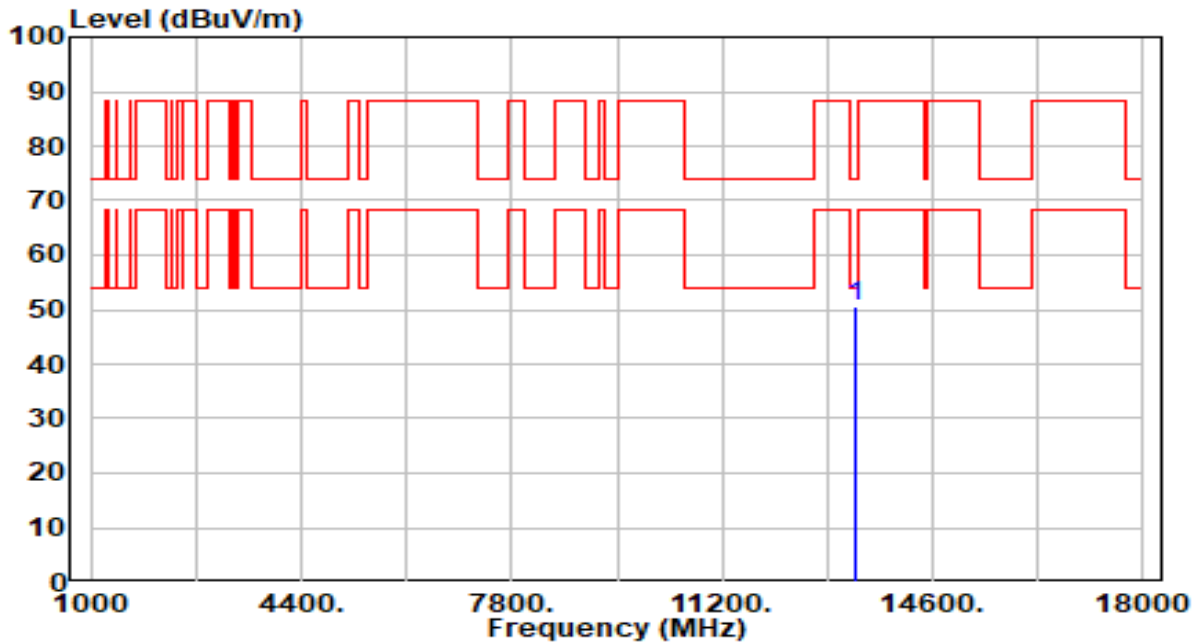

No	Frequency (MHz)	Reading (dBuV)	C.F (dB/m)	Measurement (dBuV/m)	Margin (dB)	Limit (dBuV/m)	Height (cm)	Angle (deg)	Remark (QP/PK/AV)
1	*	43.84	6.81	50.65	-23.35	74.00	200	160	Peak

Note:

- "*", means this data is the worst emission level.
- C.F (Correction Factor) = Antenna Factor (dB/m)+ Cable Loss (dB) – Preamplifier(dB).
- Measurement (dBuV/m) = Reading(dBuV) + C.F (Correction Factor).
- The emission levels of other frequencies are very lower than the limit and not show in test report.

EUT	BE11000 Tri-Band Wi-Fi 7 Gaming Router	Date of Test	2024-01-16
Factor	DRH18-E	Temp. / Humidity	21°C /63%
Polarity	Horizontal	Site / Test Engineer	AC2 / Marvin
Test Mode	802.11ax-40MHz_TX_Band7_CH 179_ANT 0+1 Nss2	Test Voltage	AC 120V/60Hz

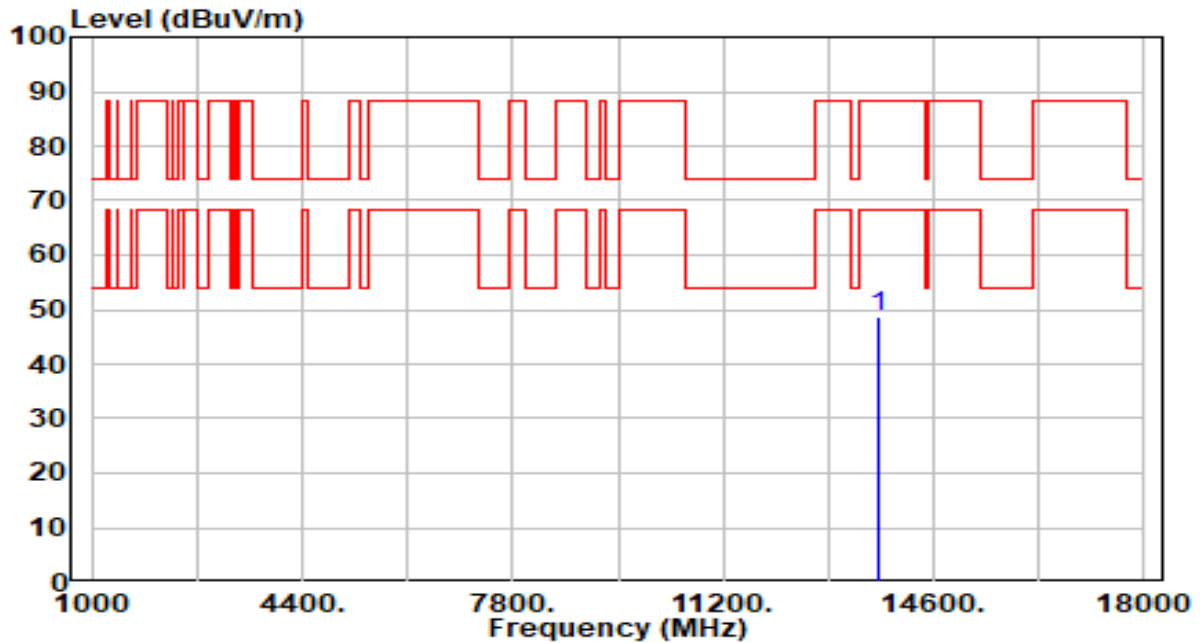

No	Frequency (MHz)	Reading (dBuV)	C.F (dB/m)	Measurement (dBuV/m)	Margin (dB)	Limit (dBuV/m)	Height (cm)	Angle (deg)	Remark (QP/PK/AV)
1	*	42.24	6.53	48.77	-39.43	88.20	200	0	Peak

Note:

1. " *", means this data is the worst emission level.
2. C.F (Correction Factor) = Antenna Factor (dB/m)+ Cable Loss (dB) – Preamplifier(dB).
3. Measurement (dBuV/m) = Reading(dBuV) + C.F (Correction Factor).
4. The emission levels of other frequencies are very lower than the limit and not show in test report.

EUT	BE11000 Tri-Band Wi-Fi 7 Gaming Router	Date of Test	2024-01-16
Factor	DRH18-E	Temp. / Humidity	21°C /63%
Polarity	Vertical	Site / Test Engineer	AC2 / Marvin
Test Mode	802.11ax-40MHz_TX_Band7_CH 179_ANT 0+1 Nss2	Test Voltage	AC 120V/60Hz

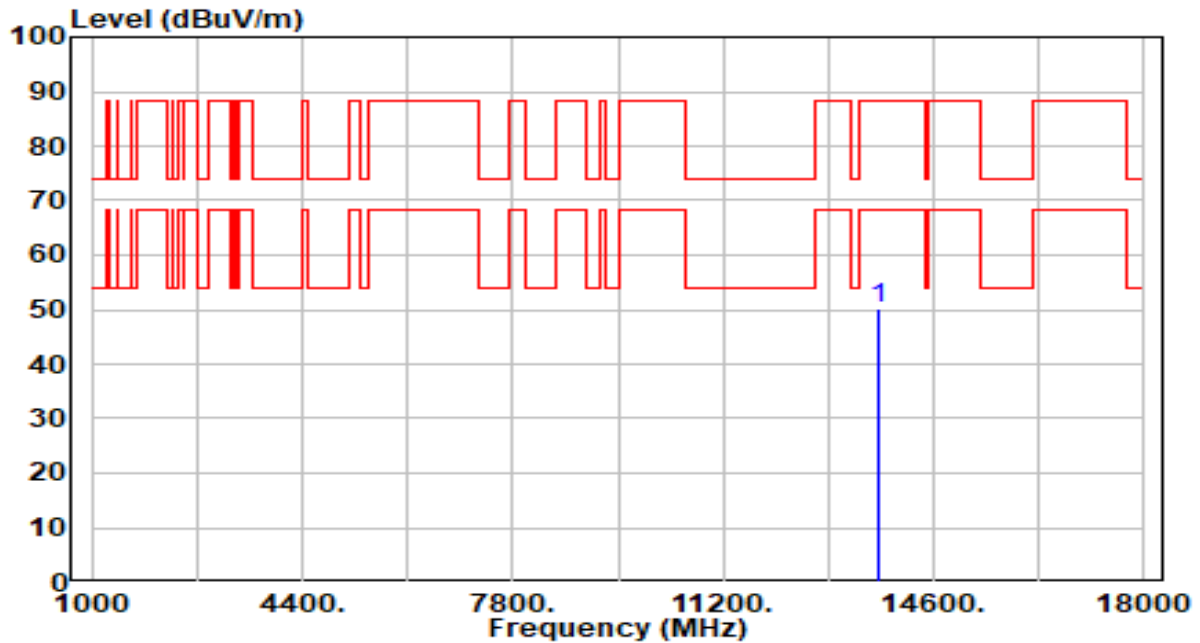

No	Frequency (MHz)	Reading (dBuV)	C.F (dB/m)	Measurement (dBuV/m)	Margin (dB)	Limit (dBuV/m)	Height (cm)	Angle (deg)	Remark (QP/PK/AV)
1	* 13690.000	43.69	6.53	50.21	-37.99	88.20	200	317	Peak

Note:

1. " *", means this data is the worst emission level.
2. C.F (Correction Factor) = Antenna Factor (dB/m)+ Cable Loss (dB) – Preamplifier(dB).
3. Measurement (dBuV/m) = Reading(dBuV) + C.F (Correction Factor).
4. The emission levels of other frequencies are very lower than the limit and not show in test report.

EUT	BE11000 Tri-Band Wi-Fi 7 Gaming Router	Date of Test	2024-01-16
Factor	DRH18-E	Temp. / Humidity	21°C /63%
Polarity	Horizontal	Site / Test Engineer	AC2 / Marvin
Test Mode	802.11ax-40MHz_TX_Band8_CH 187_ANT 0+1 Nss2	Test Voltage	AC 120V/60Hz

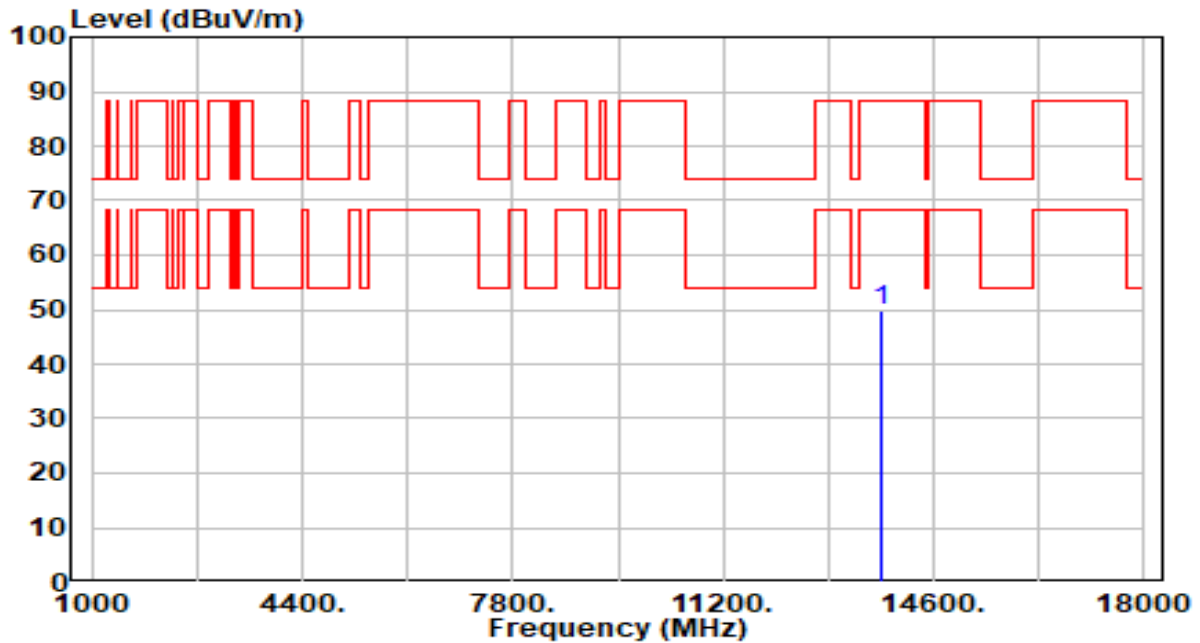

No	Frequency (MHz)	Reading (dBuV)	C.F (dB/m)	Measurement (dBuV/m)	Margin (dB)	Limit (dBuV/m)	Height (cm)	Angle (deg)	Remark (QP/PK/AV)
1	* 13770.000	43.40	6.52	49.93	-38.27	88.20	200	167	Peak

Note:

- "*", means this data is the worst emission level.
- C.F (Correction Factor) = Antenna Factor (dB/m)+ Cable Loss (dB) – Preamplifier(dB).
- Measurement (dBuV/m) = Reading(dBuV) + C.F (Correction Factor).
- The emission levels of other frequencies are very lower than the limit and not show in test report.

EUT	BE11000 Tri-Band Wi-Fi 7 Gaming Router	Date of Test	2024-01-16
Factor	DRH18-E	Temp. / Humidity	21°C /63%
Polarity	Vertical	Site / Test Engineer	AC2 / Marvin
Test Mode	802.11ax-40MHz_TX_Band8_CH 187_ANT 0+1 Nss2	Test Voltage	AC 120V/60Hz

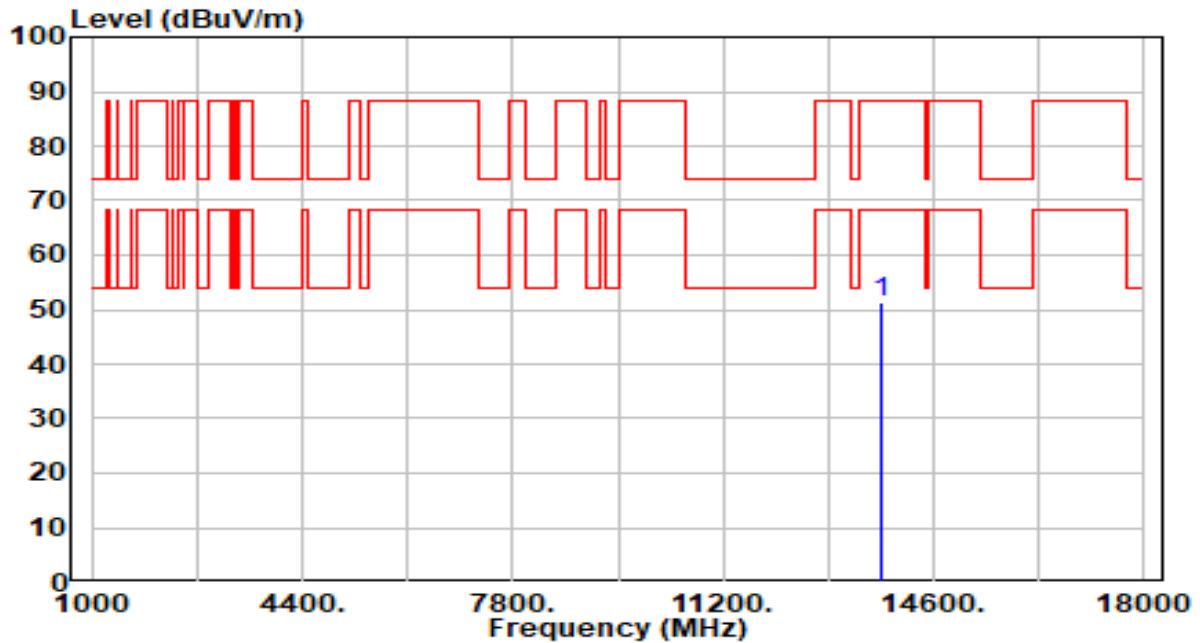

No	Frequency (MHz)	Reading (dBuV)	C.F (dB/m)	Measurement (dBuV/m)	Margin (dB)	Limit (dBuV/m)	Height (cm)	Angle (deg)	Remark (QP/PK/AV)
1	* 13770.000	44.68	6.52	51.21	-36.99	88.20	200	136	Peak

Note:

1. " *", means this data is the worst emission level.
2. C.F (Correction Factor) = Antenna Factor (dB/m)+ Cable Loss (dB) – Preamplifier(dB).
3. Measurement (dBuV/m) = Reading(dBuV) + C.F (Correction Factor).
4. The emission levels of other frequencies are very lower than the limit and not show in test report.

EUT	BE11000 Tri-Band Wi-Fi 7 Gaming Router	Date of Test	2024-01-16
Factor	DRH18-E	Temp. / Humidity	21°C /63%
Polarity	Horizontal	Site / Test Engineer	AC2 / Marvin
Test Mode	802.11ax-40MHz_TX_Band8_CH 195_ANT 0+1 Nss2	Test Voltage	AC 120V/60Hz

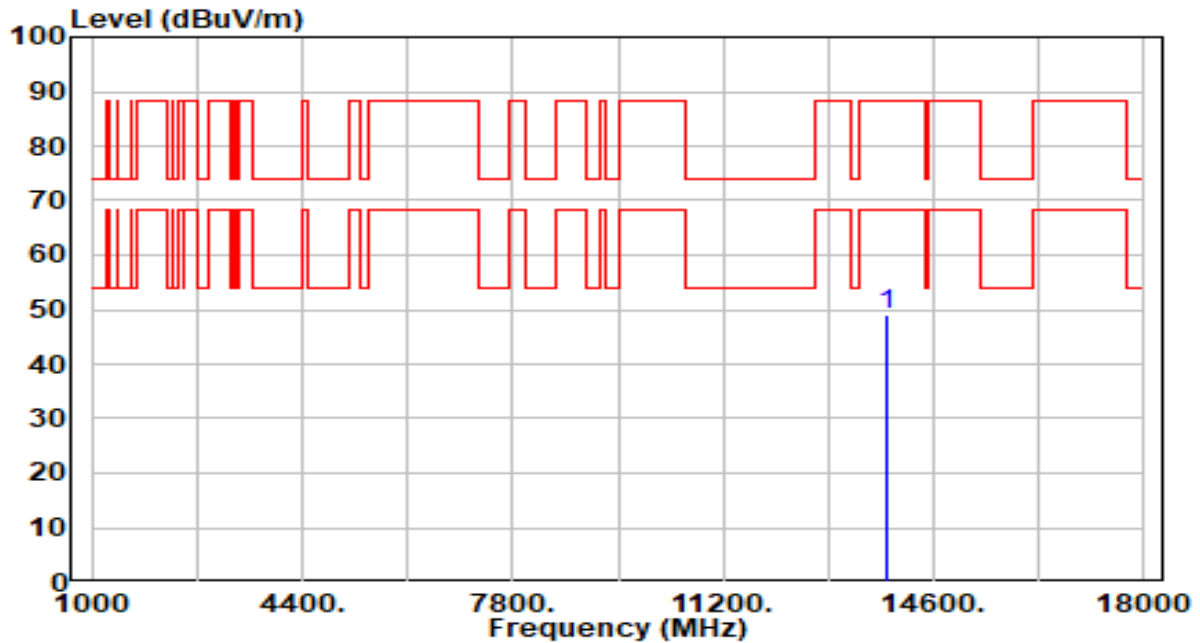

No	Frequency (MHz)	Reading (dBuV)	C.F (dB/m)	Measurement (dBuV/m)	Margin (dB)	Limit (dBuV/m)	Height (cm)	Angle (deg)	Remark (QP/PK/AV)
1	* 13850.000	42.47	6.55	49.01	-39.19	88.20	200	54	Peak

Note:

1. " *", means this data is the worst emission level.
2. C.F (Correction Factor) = Antenna Factor (dB/m)+ Cable Loss (dB) – Preamplifier(dB).
3. Measurement (dBuV/m) = Reading(dBuV) + C.F (Correction Factor).
4. The emission levels of other frequencies are very lower than the limit and not show in test report.

EUT	BE11000 Tri-Band Wi-Fi 7 Gaming Router	Date of Test	2024-01-16
Factor	DRH18-E	Temp. / Humidity	21°C /63%
Polarity	Vertical	Site / Test Engineer	AC2 / Marvin
Test Mode	802.11ax-40MHz_TX_Band8_CH 195_ANT 0+1 Nss2	Test Voltage	AC 120V/60Hz

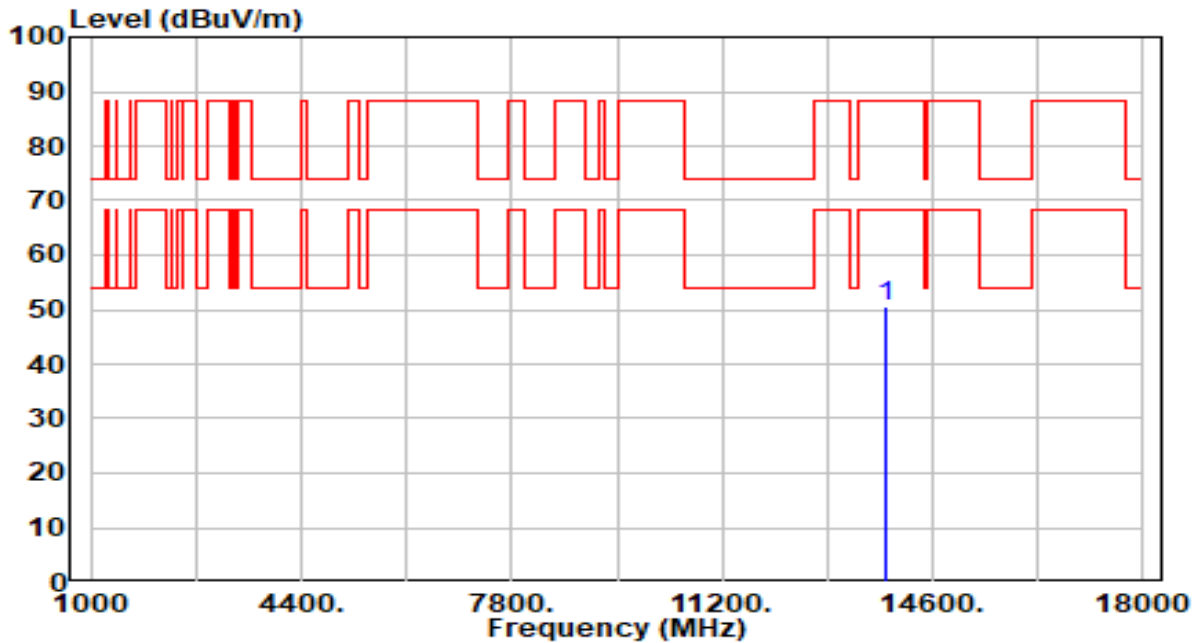

No	Frequency (MHz)	Reading (dBuV)	C.F (dB/m)	Measurement (dBuV/m)	Margin (dB)	Limit (dBuV/m)	Height (cm)	Angle (deg)	Remark (QP/PK/AV)
1	* 13850.000	44.04	6.55	50.59	-37.61	88.20	200	318	Peak

Note:

1. " *", means this data is the worst emission level.
2. C.F (Correction Factor) = Antenna Factor (dB/m)+ Cable Loss (dB) – Preamplifier(dB).
3. Measurement (dBuV/m) = Reading(dBuV) + C.F (Correction Factor).
4. The emission levels of other frequencies are very lower than the limit and not show in test report.

EUT	BE11000 Tri-Band Wi-Fi 7 Gaming Router	Date of Test	2024-01-16
Factor	DRH18-E	Temp. / Humidity	21°C /63%
Polarity	Horizontal	Site / Test Engineer	AC2 / Marvin
Test Mode	802.11ax-40MHz_TX_Band8_CH 211_ANT 0+1 Nss2	Test Voltage	AC 120V/60Hz

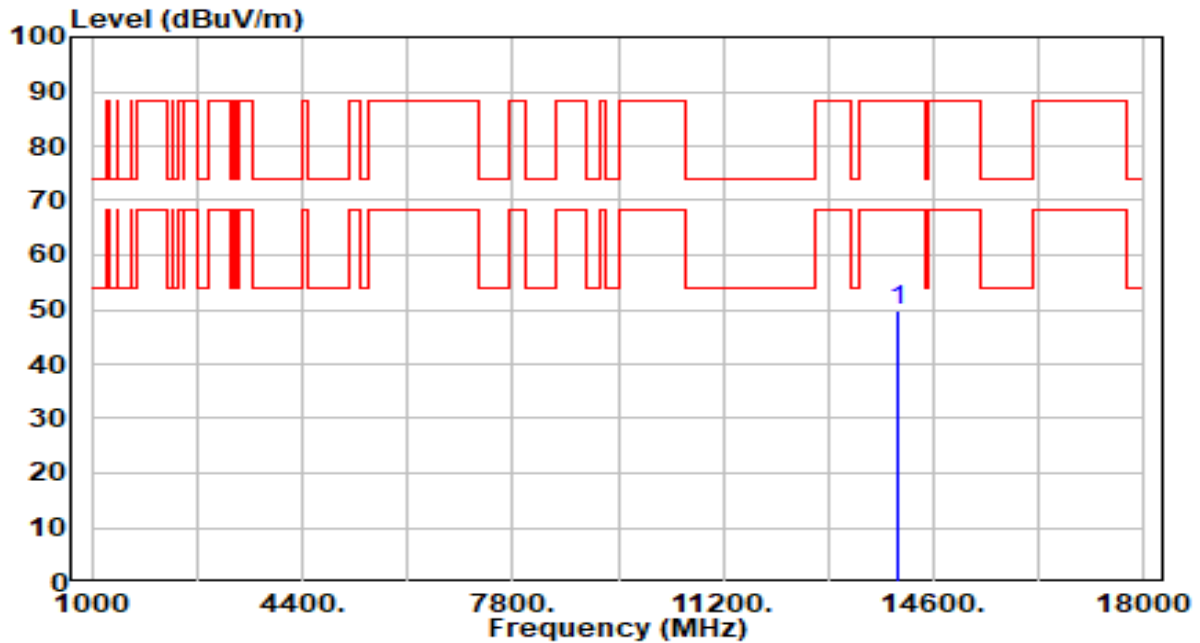

No	Frequency (MHz)	Reading (dBuV)	C.F (dB/m)	Measurement (dBuV/m)	Margin (dB)	Limit (dBuV/m)	Height (cm)	Angle (deg)	Remark (QP/PK/AV)
1	* 14010.000	43.27	6.62	49.89	-38.31	88.20	200	336	Peak

Note:

- "*", means this data is the worst emission level.
- C.F (Correction Factor) = Antenna Factor (dB/m)+ Cable Loss (dB) – Preamplifier(dB).
- Measurement (dBuV/m) = Reading(dBuV) + C.F (Correction Factor).
- The emission levels of other frequencies are very lower than the limit and not show in test report.

EUT	BE11000 Tri-Band Wi-Fi 7 Gaming Router	Date of Test	2024-01-16
Factor	DRH18-E	Temp. / Humidity	21°C /63%
Polarity	Vertical	Site / Test Engineer	AC2 / Marvin
Test Mode	802.11ax-40MHz_TX_Band8_CH 211_ANT 0+1 Nss2	Test Voltage	AC 120V/60Hz

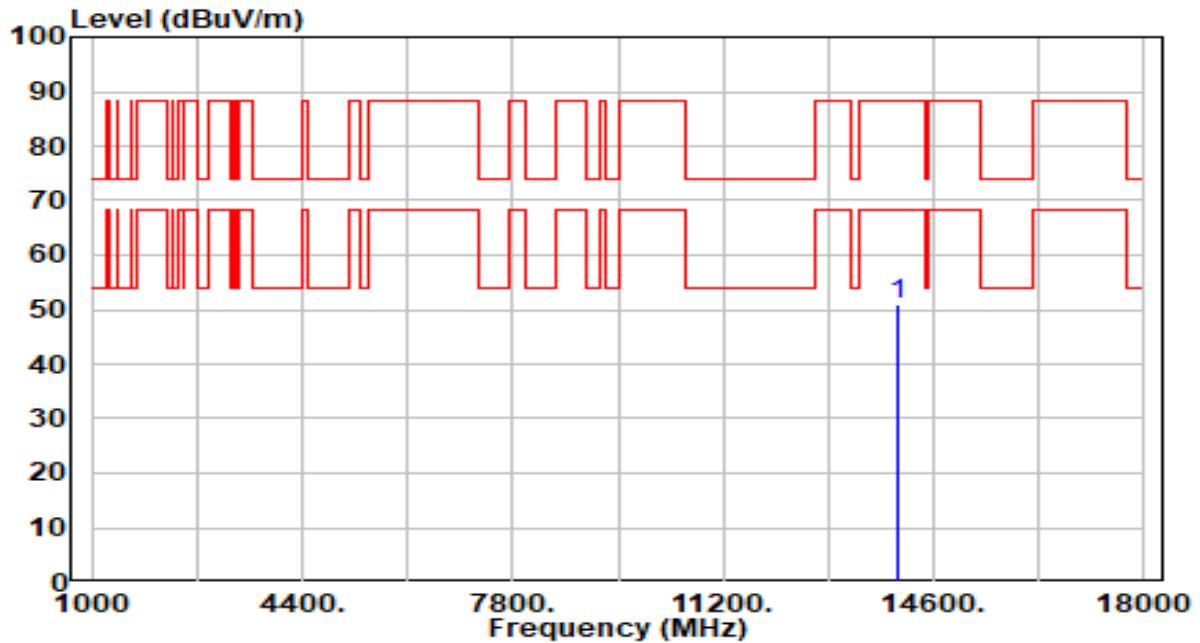

No	Frequency (MHz)	Reading (dBuV)	C.F (dB/m)	Measurement (dBuV/m)	Margin (dB)	Limit (dBuV/m)	Height (cm)	Angle (deg)	Remark (QP/PK/AV)
1	* 14010.000	44.20	6.62	50.82	-37.38	88.20	200	300	Peak

Note:

- "*", means this data is the worst emission level.
- C.F (Correction Factor) = Antenna Factor (dB/m)+ Cable Loss (dB) – Preamplifier(dB).
- Measurement (dBuV/m) = Reading(dBuV) + C.F (Correction Factor).
- The emission levels of other frequencies are very lower than the limit and not show in test report.

EUT	BE11000 Tri-Band Wi-Fi 7 Gaming Router	Date of Test	2024-01-16
Factor	DRH18-E	Temp. / Humidity	21°C /63%
Polarity	Horizontal	Site / Test Engineer	AC2 / Marvin
Test Mode	802.11ax-40MHz_TX_Band8_CH 227_ANT 0+1 Nss2	Test Voltage	AC 120V/60Hz

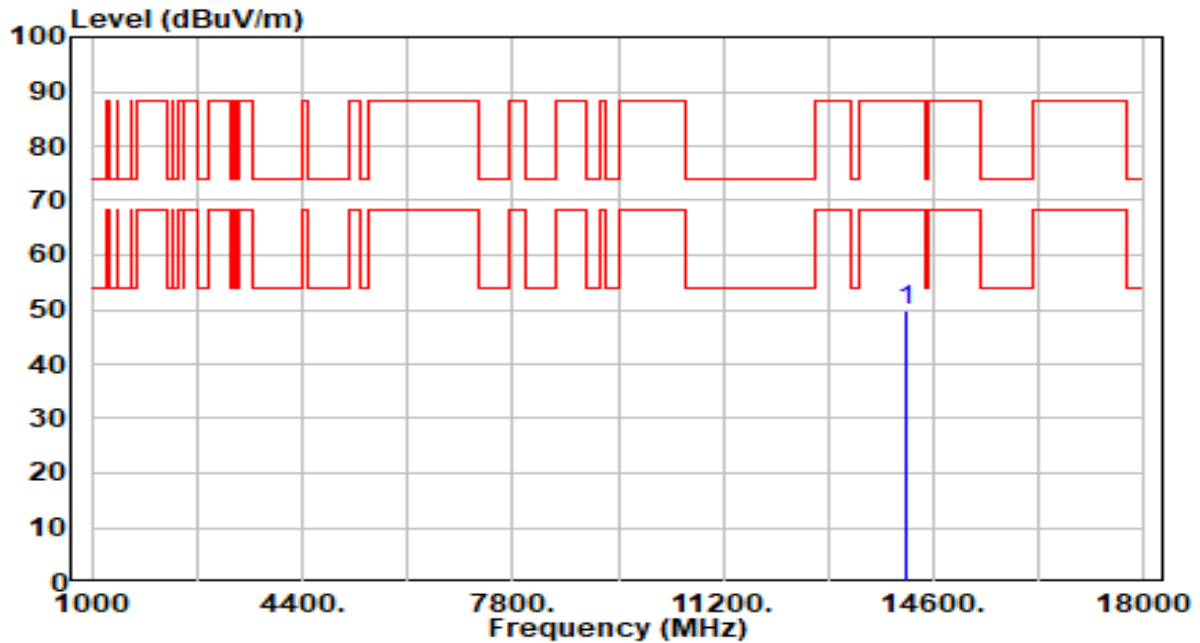

No	Frequency (MHz)	Reading (dBuV)	C.F (dB/m)	Measurement (dBuV/m)	Margin (dB)	Limit (dBuV/m)	Height (cm)	Angle (deg)	Remark (QP/PK/AV)
1	*	43.23	6.65	49.88	-38.32	88.20	200	183	Peak

Note:

1. " *", means this data is the worst emission level.
2. C.F (Correction Factor) = Antenna Factor (dB/m)+ Cable Loss (dB) – Preamplifier(dB).
3. Measurement (dBuV/m) = Reading(dBuV) + C.F (Correction Factor).
4. The emission levels of other frequencies are very lower than the limit and not show in test report.

EUT	BE11000 Tri-Band Wi-Fi 7 Gaming Router	Date of Test	2024-01-16
Factor	DRH18-E	Temp. / Humidity	21°C /63%
Polarity	Vertical	Site / Test Engineer	AC2 / Marvin
Test Mode	802.11ax-40MHz_TX_Band8_CH 227_ANT 0+1 Nss2	Test Voltage	AC 120V/60Hz

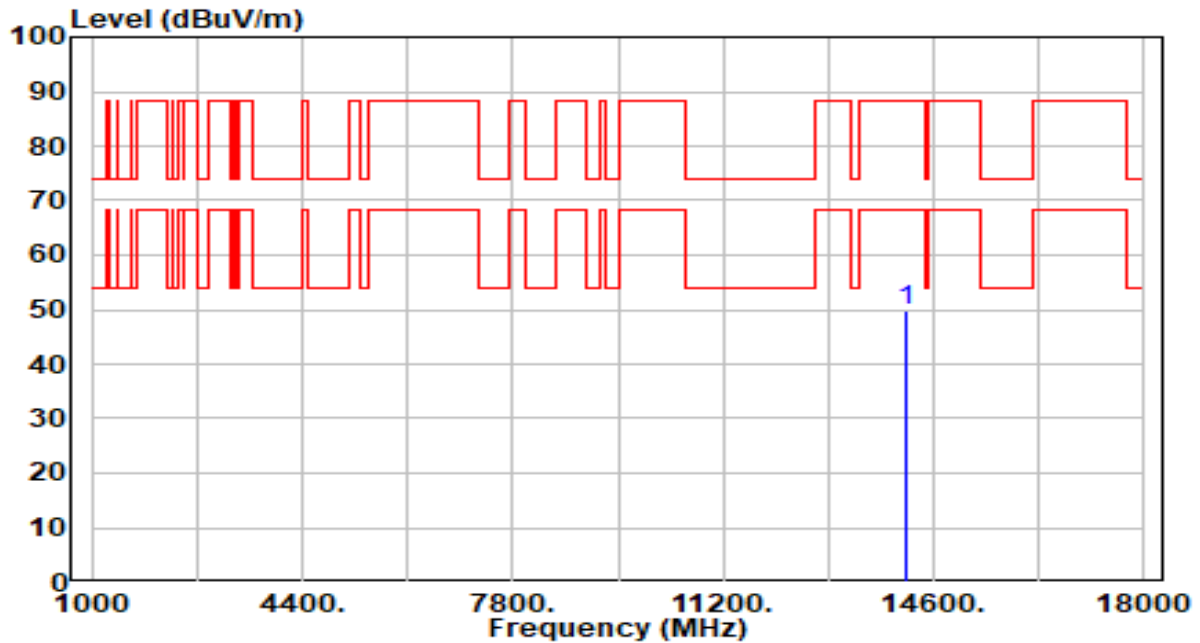

No	Frequency (MHz)	Reading (dBuV)	C.F (dB/m)	Measurement (dBuV/m)	Margin (dB)	Limit (dBuV/m)	Height (cm)	Angle (deg)	Remark (QP/PK/AV)
1	* 14170.000	43.08	6.65	49.73	-38.47	88.20	200	346	Peak

Note:

1. " *", means this data is the worst emission level.
2. C.F (Correction Factor) = Antenna Factor (dB/m)+ Cable Loss (dB) – Preamplifier(dB).
3. Measurement (dBuV/m) = Reading(dBuV) + C.F (Correction Factor).
4. The emission levels of other frequencies are very lower than the limit and not show in test report.

EUT	BE11000 Tri-Band Wi-Fi 7 Gaming Router	Date of Test	2024-01-16
Factor	DRH18-E	Temp. / Humidity	21°C /63%
Polarity	Horizontal	Site / Test Engineer	AC2 / Stanley
Test Mode	802.11ax-160MHz_TX_Band5_CH 15_ANT 0+1 Nss2	Test Voltage	AC 120V/60Hz

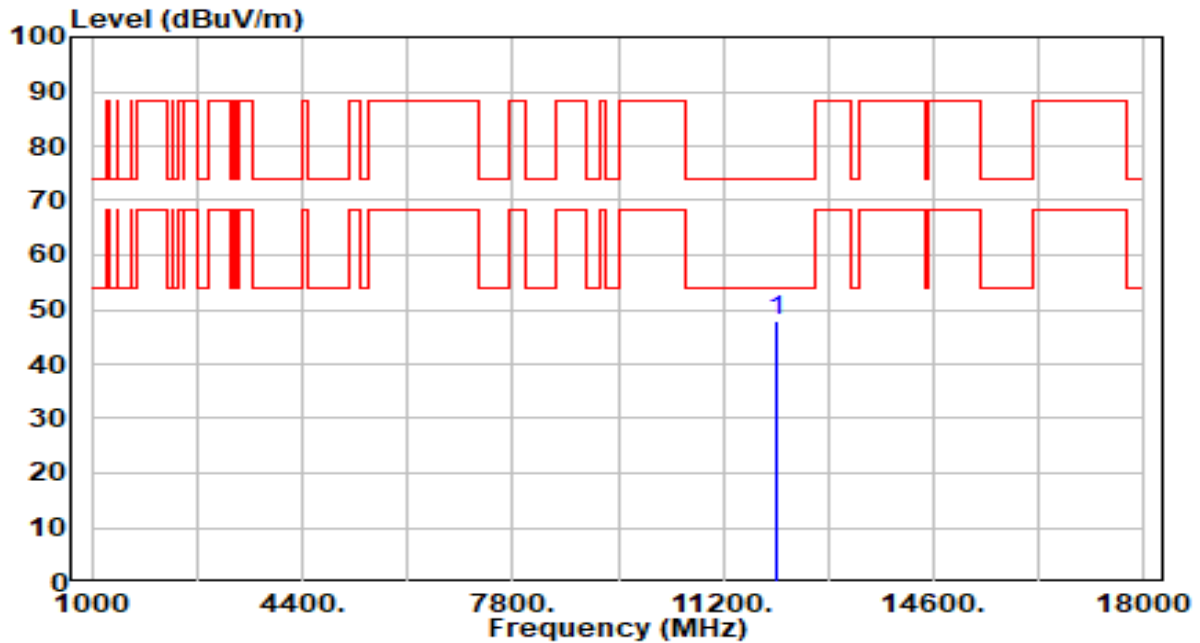

No	Frequency (MHz)	Reading (dBuV)	C.F (dB/m)	Measurement (dBuV/m)	Margin (dB)	Limit (dBuV/m)	Height (cm)	Angle (deg)	Remark (QP/PK/AV)
1	*	42.50	5.60	48.10	-25.90	74.00	200	103	Peak

Note:

1. " *", means this data is the worst emission level.
2. C.F (Correction Factor) = Antenna Factor (dB/m)+ Cable Loss (dB) – Preamplifier(dB).
3. Measurement (dBuV/m) = Reading(dBuV) + C.F (Correction Factor).
4. The emission levels of other frequencies are very lower than the limit and not show in test report.

EUT	BE11000 Tri-Band Wi-Fi 7 Gaming Router	Date of Test	2024-01-16
Factor	DRH18-E	Temp. / Humidity	21°C /63%
Polarity	Vertical	Site / Test Engineer	AC2 / Stanley
Test Mode	802.11ax-160MHz_TX_Band5_CH 15_ANT 0+1 Nss2	Test Voltage	AC 120V/60Hz

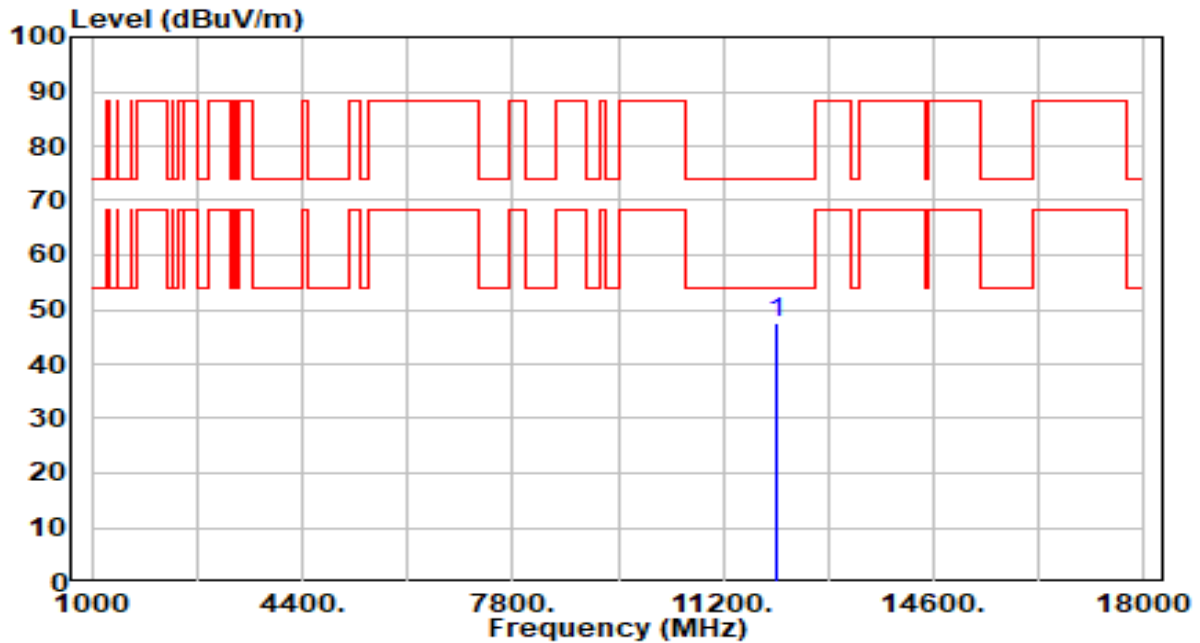

No	Frequency (MHz)	Reading (dBuV)	C.F (dB/m)	Measurement (dBuV/m)	Margin (dB)	Limit (dBuV/m)	Height (cm)	Angle (deg)	Remark (QP/PK/AV)
1	*	41.94	5.60	47.53	-26.47	74.00	200	111	Peak

Note:

1. " *", means this data is the worst emission level.
2. C.F (Correction Factor) = Antenna Factor (dB/m)+ Cable Loss (dB) – Preamplifier(dB).
3. Measurement (dBuV/m) = Reading(dBuV) + C.F (Correction Factor).
4. The emission levels of other frequencies are very lower than the limit and not show in test report.

EUT	BE11000 Tri-Band Wi-Fi 7 Gaming Router	Date of Test	2024-01-16
Factor	DRH18-E	Temp. / Humidity	21°C /63%
Polarity	Horizontal	Site / Test Engineer	AC2 / Stanley
Test Mode	802.11ax-160MHz_TX_Band5_CH 47_ANT 0+1 Nss2	Test Voltage	AC 120V/60Hz

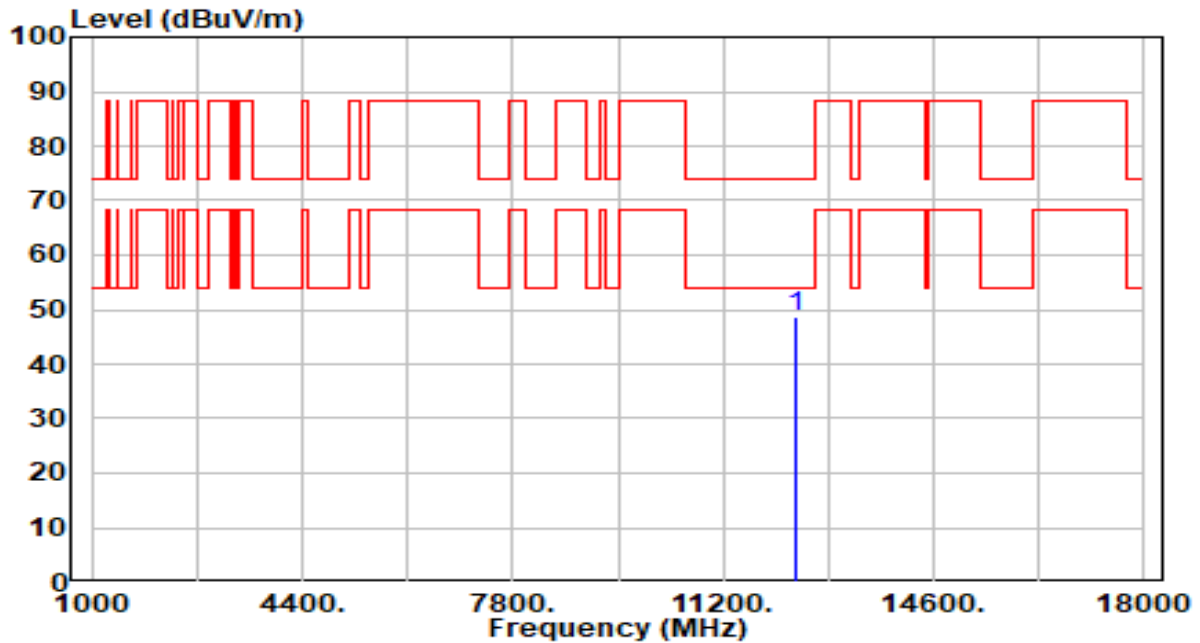

No	Frequency (MHz)	Reading (dBuV)	C.F (dB/m)	Measurement (dBuV/m)	Margin (dB)	Limit (dBuV/m)	Height (cm)	Angle (deg)	Remark (QP/PK/AV)
1	*	42.45	6.12	48.57	-25.43	74.00	200	78	Peak

Note:

- "*", means this data is the worst emission level.
- C.F (Correction Factor) = Antenna Factor (dB/m)+ Cable Loss (dB) – Preamplifier(dB).
- Measurement (dBuV/m) = Reading(dBuV) + C.F (Correction Factor).
- The emission levels of other frequencies are very lower than the limit and not show in test report.

EUT	BE11000 Tri-Band Wi-Fi 7 Gaming Router	Date of Test	2024-01-16
Factor	DRH18-E	Temp. / Humidity	21°C /63%
Polarity	Vertical	Site / Test Engineer	AC2 / Stanley
Test Mode	802.11ax-160MHz_TX_Band5_CH 47_ANT 0+1 Nss2	Test Voltage	AC 120V/60Hz

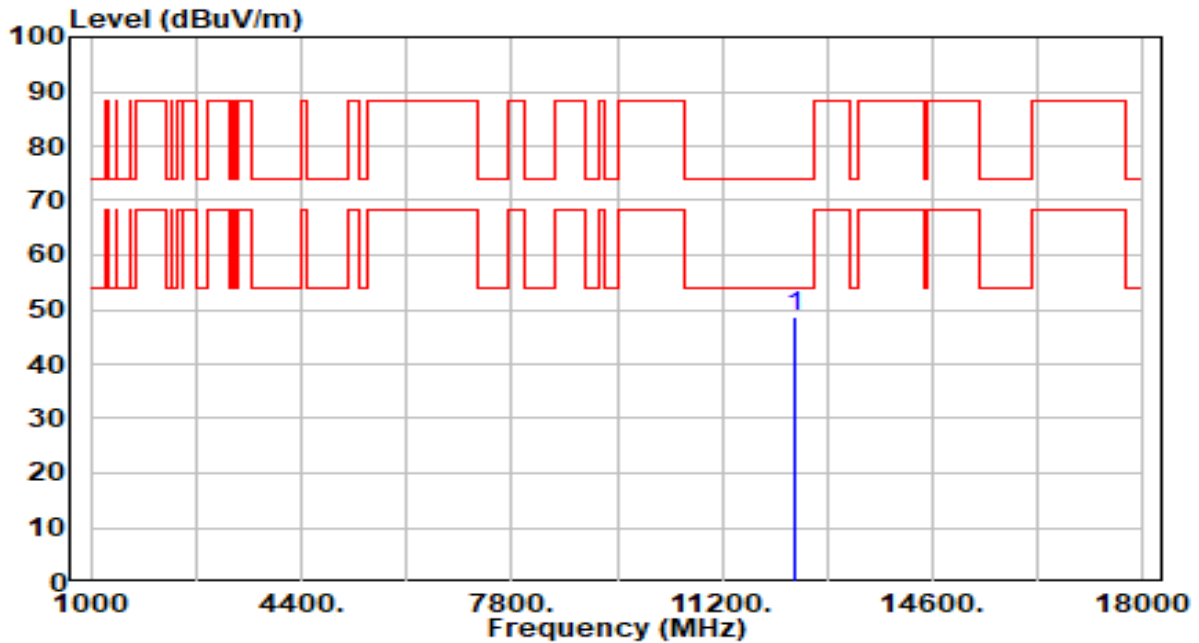

No	Frequency (MHz)	Reading (dBuV)	C.F (dB/m)	Measurement (dBuV/m)	Margin (dB)	Limit (dBuV/m)	Height (cm)	Angle (deg)	Remark (QP/PK/AV)
1	* 12370.000	42.58	6.12	48.71	-25.29	74.00	200	308	Peak

Note:

1. " *", means this data is the worst emission level.
2. C.F (Correction Factor) = Antenna Factor (dB/m)+ Cable Loss (dB) – Preamplifier(dB).
3. Measurement (dBuV/m) = Reading(dBuV) + C.F (Correction Factor).
4. The emission levels of other frequencies are very lower than the limit and not show in test report.

EUT	BE11000 Tri-Band Wi-Fi 7 Gaming Router	Date of Test	2024-01-16
Factor	DRH18-E	Temp. / Humidity	21°C /63%
Polarity	Horizontal	Site / Test Engineer	AC2 / Stanley
Test Mode	802.11ax-160MHz_TX_Band5_CH 79_ANT 0+1 Nss2	Test Voltage	AC 120V/60Hz

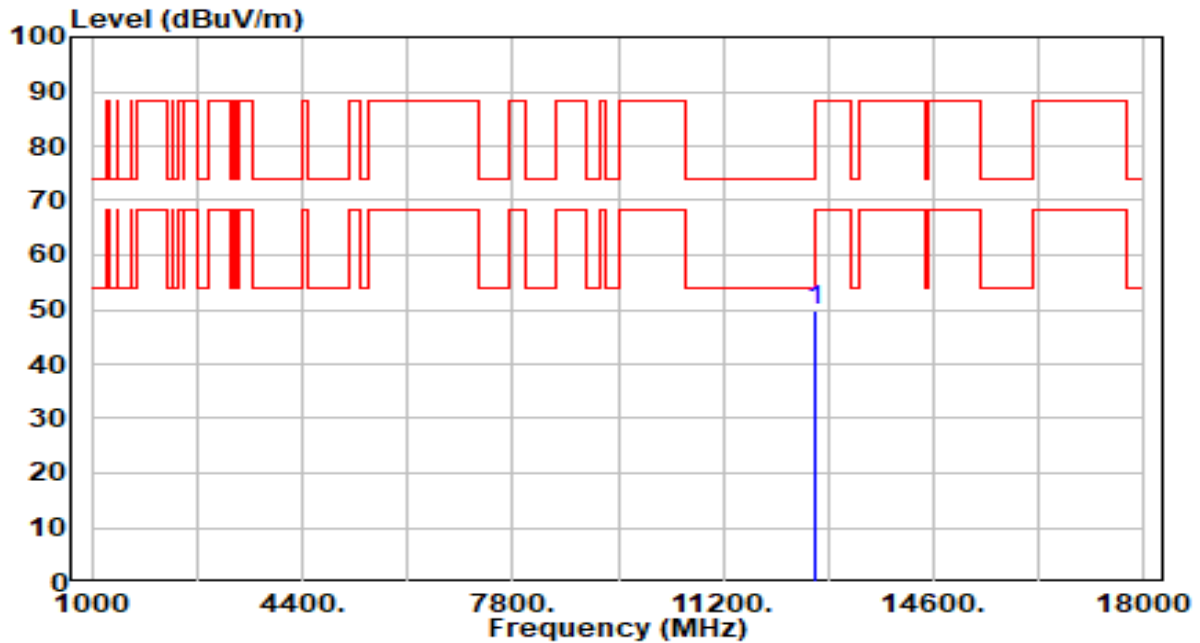

No	Frequency (MHz)	Reading (dBuV)	C.F (dB/m)	Measurement (dBuV/m)	Margin (dB)	Limit (dBuV/m)	Height (cm)	Angle (deg)	Remark (QP/PK/AV)
1	*	42.97	6.84	49.82	-24.18	74.00	200	338	Peak

Note:

- "*", means this data is the worst emission level.
- C.F (Correction Factor) = Antenna Factor (dB/m)+ Cable Loss (dB) – Preamplifier(dB).
- Measurement (dBuV/m) = Reading(dBuV) + C.F (Correction Factor).
- The emission levels of other frequencies are very lower than the limit and not show in test report.

EUT	BE11000 Tri-Band Wi-Fi 7 Gaming Router	Date of Test	2024-01-16
Factor	DRH18-E	Temp. / Humidity	21°C /63%
Polarity	Vertical	Site / Test Engineer	AC2 / Stanley
Test Mode	802.11ax-160MHz_TX_Band5_CH 79_ANT 0+1 Nss2	Test Voltage	AC 120V/60Hz

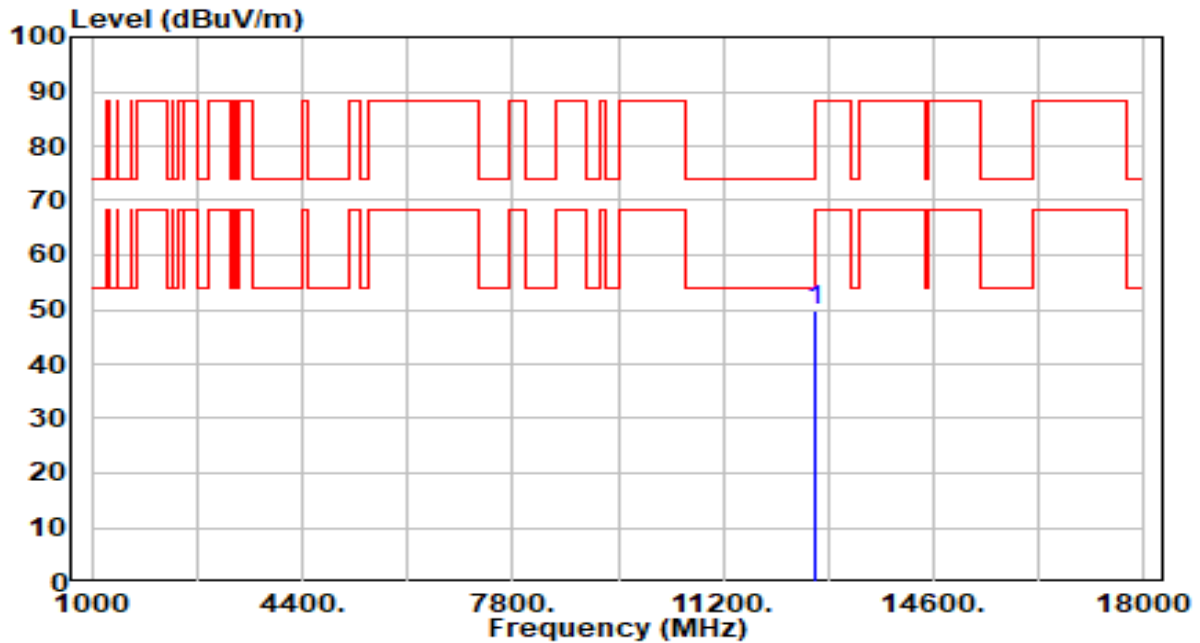

No	Frequency (MHz)	Reading (dBuV)	C.F (dB/m)	Measurement (dBuV/m)	Margin (dB)	Limit (dBuV/m)	Height (cm)	Angle (deg)	Remark (QP/PK/AV)
1	*	42.96	6.84	49.80	-24.20	74.00	200	162	Peak

Note:

- "*", means this data is the worst emission level.
- C.F (Correction Factor) = Antenna Factor (dB/m)+ Cable Loss (dB) – Preamplifier(dB).
- Measurement (dBuV/m) = Reading(dBuV) + C.F (Correction Factor).
- The emission levels of other frequencies are very lower than the limit and not show in test report.

EUT	BE11000 Tri-Band Wi-Fi 7 Gaming Router	Date of Test	2024-01-16
Factor	DRH18-E	Temp. / Humidity	21°C /63%
Polarity	Horizontal	Site / Test Engineer	AC2 / Stanley
Test Mode	802.11ax-160MHz_TX_Band6_CH 111_ANT 0+1 Nss2	Test Voltage	AC 120V/60Hz

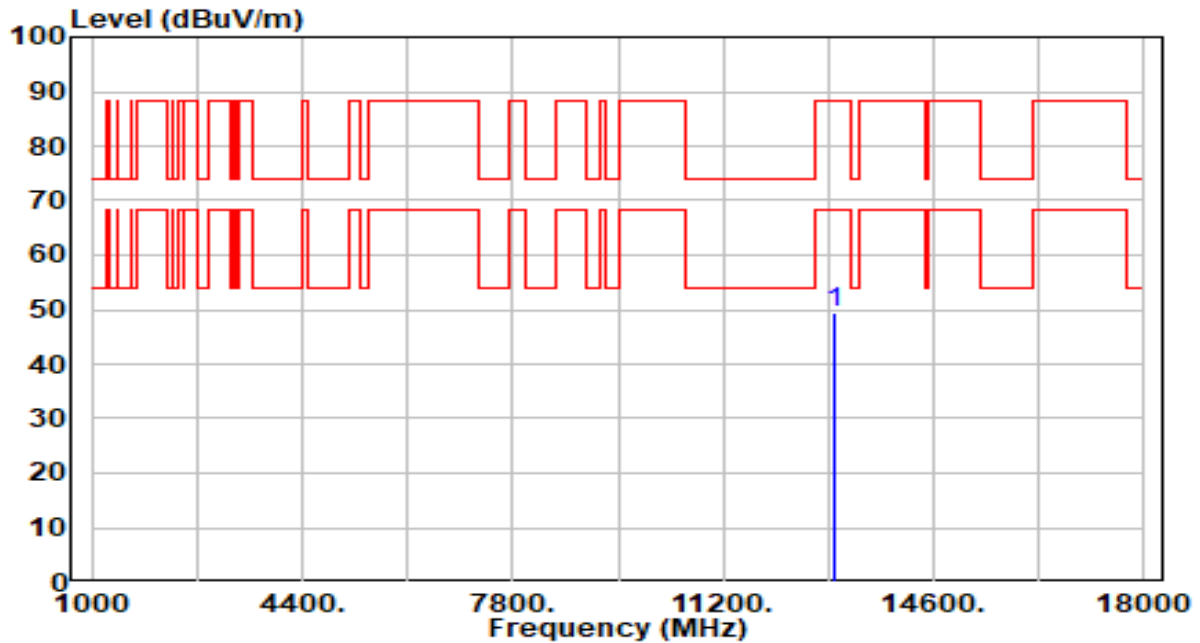

No	Frequency (MHz)	Reading (dBuV)	C.F (dB/m)	Measurement (dBuV/m)	Margin (dB)	Limit (dBuV/m)	Height (cm)	Angle (deg)	Remark (QP/PK/AV)
1	* 13010.000	42.63	6.87	49.50	-38.70	88.20	200	342	Peak

Note:

1. " *", means this data is the worst emission level.
2. C.F (Correction Factor) = Antenna Factor (dB/m)+ Cable Loss (dB) – Preamplifier(dB).
3. Measurement (dBuV/m) = Reading(dBuV) + C.F (Correction Factor).
4. The emission levels of other frequencies are very lower than the limit and not show in test report.

EUT	BE11000 Tri-Band Wi-Fi 7 Gaming Router	Date of Test	2024-01-16
Factor	DRH18-E	Temp. / Humidity	21°C /63%
Polarity	Vertical	Site / Test Engineer	AC2 / Stanley
Test Mode	802.11ax-160MHz_TX_Band6_CH 111_ANT 0+1 Nss2	Test Voltage	AC 120V/60Hz

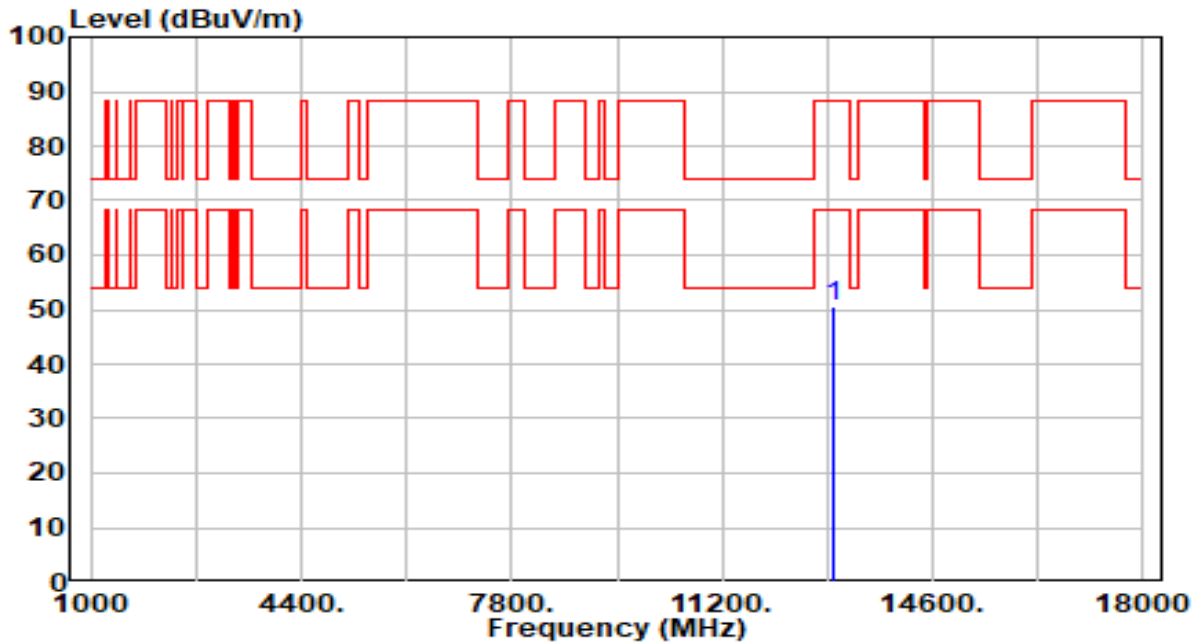

No	Frequency (MHz)	Reading (dBuV)	C.F (dB/m)	Measurement (dBuV/m)	Margin (dB)	Limit (dBuV/m)	Height (cm)	Angle (deg)	Remark (QP/PK/AV)
1	* 13010.000	43.56	6.87	50.42	-37.78	88.20	200	162	Peak

Note:

1. " *", means this data is the worst emission level.
2. C.F (Correction Factor) = Antenna Factor (dB/m)+ Cable Loss (dB) – Preamplifier(dB).
3. Measurement (dBuV/m) = Reading(dBuV) + C.F (Correction Factor).
4. The emission levels of other frequencies are very lower than the limit and not show in test report.

EUT	BE11000 Tri-Band Wi-Fi 7 Gaming Router	Date of Test	2024-01-16
Factor	DRH18-E	Temp. / Humidity	21°C /63%
Polarity	Horizontal	Site / Test Engineer	AC2 / Stanley
Test Mode	802.11ax-160MHz_TX_Band7_CH 143_ANT 0+1 Nss2	Test Voltage	AC 120V/60Hz

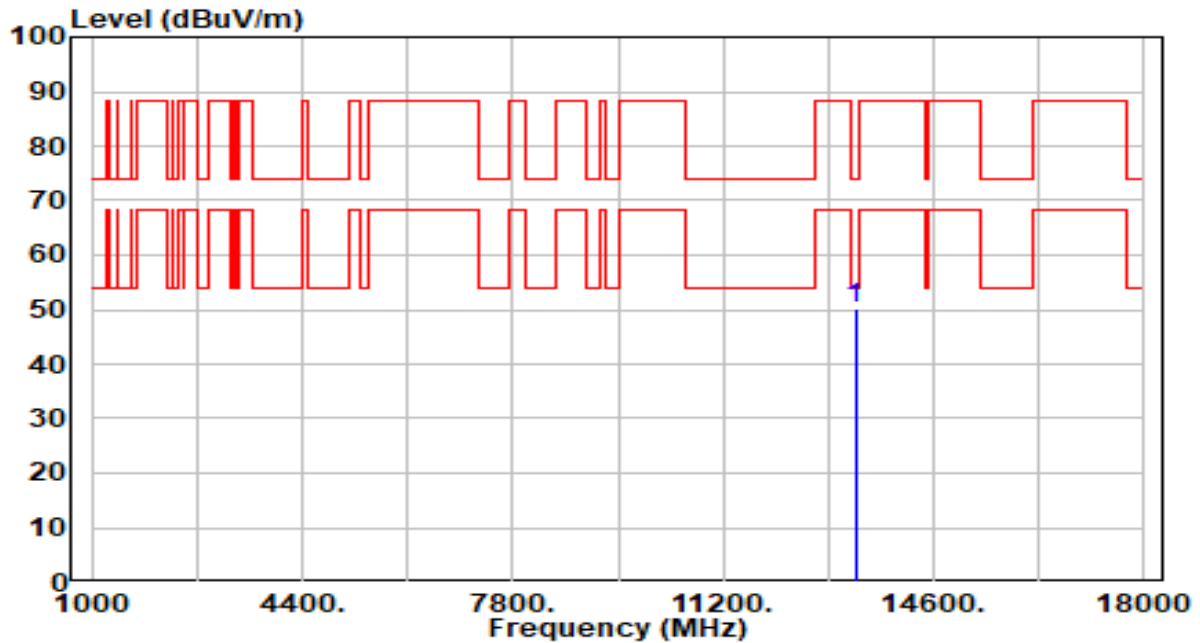

No	Frequency (MHz)	Reading (dBuV)	C.F (dB/m)	Measurement (dBuV/m)	Margin (dB)	Limit (dBuV/m)	Height (cm)	Angle (deg)	Remark (QP/PK/AV)
1	*	43.38	6.81	50.19	-23.81	74.00	200	200	Peak

Note:

- "*", means this data is the worst emission level.
- C.F (Correction Factor) = Antenna Factor (dB/m)+ Cable Loss (dB) – Preamplifier(dB).
- Measurement (dBuV/m) = Reading(dBuV) + C.F (Correction Factor).
- The emission levels of other frequencies are very lower than the limit and not show in test report.

EUT	BE11000 Tri-Band Wi-Fi 7 Gaming Router	Date of Test	2024-01-16
Factor	DRH18-E	Temp. / Humidity	21°C /63%
Polarity	Vertical	Site / Test Engineer	AC2 / Stanley
Test Mode	802.11ax-160MHz_TX_Band7_CH 143_ANT 0+1 Nss2	Test Voltage	AC 120V/60Hz

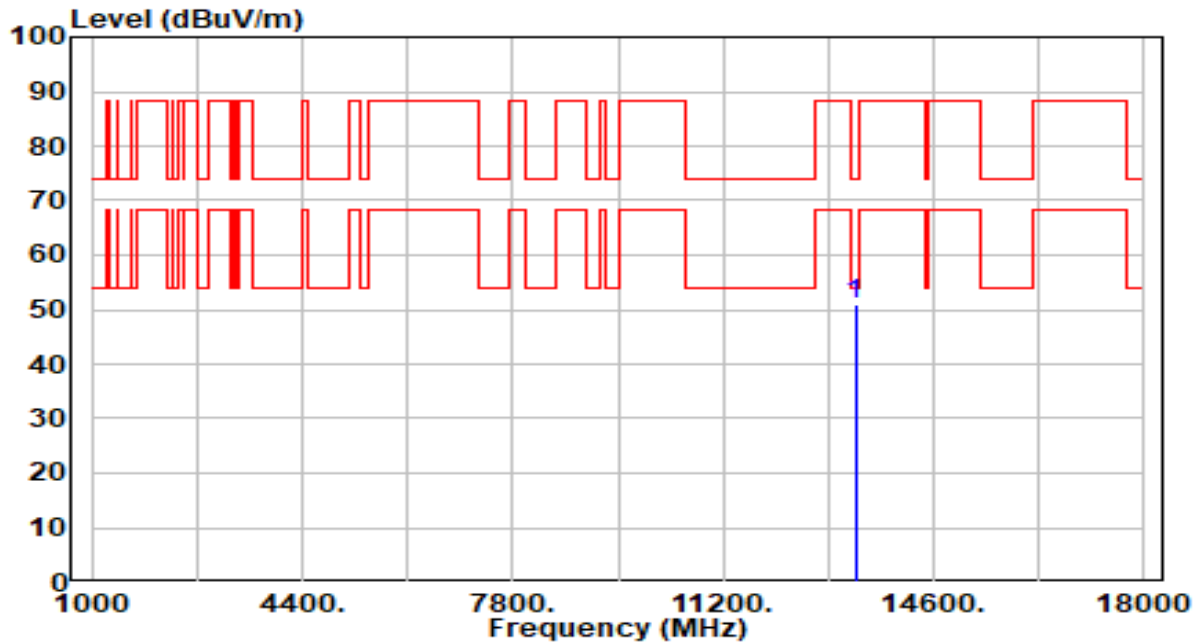

No	Frequency (MHz)	Reading (dBuV)	C.F (dB/m)	Measurement (dBuV/m)	Margin (dB)	Limit (dBuV/m)	Height (cm)	Angle (deg)	Remark (QP/PK/AV)
1	*	44.17	6.81	50.98	-23.02	74.00	200	71	Peak

Note:

- "*", means this data is the worst emission level.
- C.F (Correction Factor) = Antenna Factor (dB/m)+ Cable Loss (dB) – Preamplifier(dB).
- Measurement (dBuV/m) = Reading(dBuV) + C.F (Correction Factor).
- The emission levels of other frequencies are very lower than the limit and not show in test report.

EUT	BE11000 Tri-Band Wi-Fi 7 Gaming Router	Date of Test	2024-01-16
Factor	DRH18-E	Temp. / Humidity	21°C /63%
Polarity	Horizontal	Site / Test Engineer	AC2 / Stanley
Test Mode	802.11ax-160MHz_TX_Band7_CH 175_ANT 0+1 Nss2	Test Voltage	AC 120V/60Hz

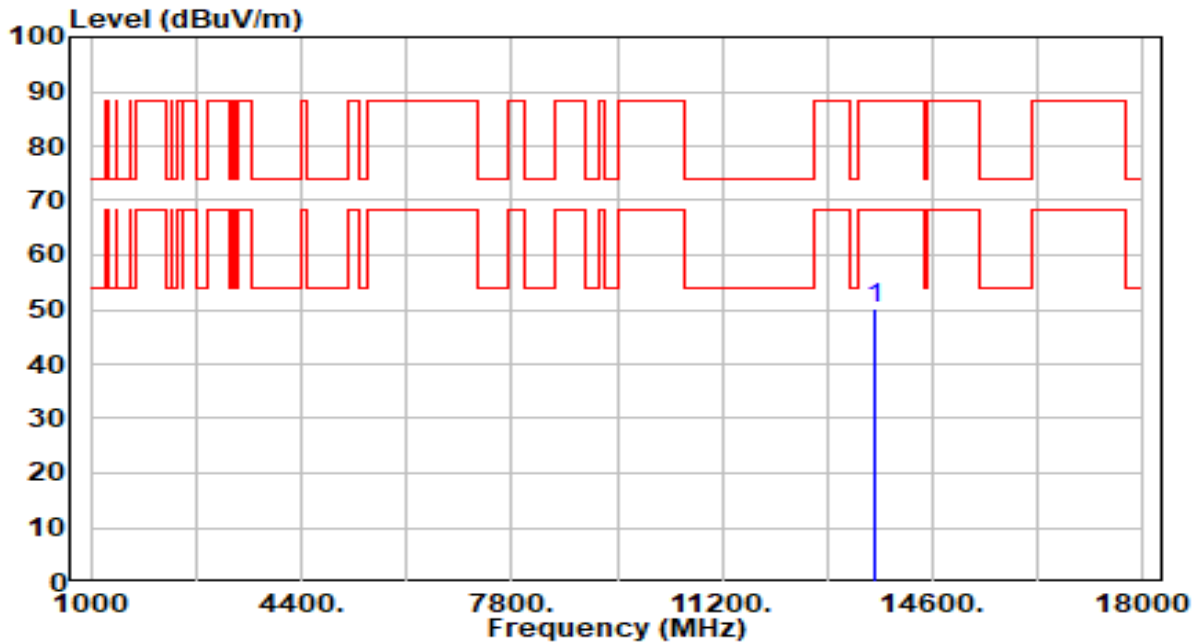

No	Frequency (MHz)	Reading (dBuV)	C.F (dB/m)	Measurement (dBuV/m)	Margin (dB)	Limit (dBuV/m)	Height (cm)	Angle (deg)	Remark (QP/PK/AV)
1	*	43.65	6.53	50.17	-38.03	88.20	200	87	Peak

Note:

1. " *", means this data is the worst emission level.
2. C.F (Correction Factor) = Antenna Factor (dB/m)+ Cable Loss (dB) – Preamplifier(dB).
3. Measurement (dBuV/m) = Reading(dBuV) + C.F (Correction Factor).
4. The emission levels of other frequencies are very lower than the limit and not show in test report.

EUT	BE11000 Tri-Band Wi-Fi 7 Gaming Router	Date of Test	2024-01-16
Factor	DRH18-E	Temp. / Humidity	21°C /63%
Polarity	Vertical	Site / Test Engineer	AC2 / Stanley
Test Mode	802.11ax-160MHz_TX_Band7_CH 175_ANT 0+1 Nss2	Test Voltage	AC 120V/60Hz

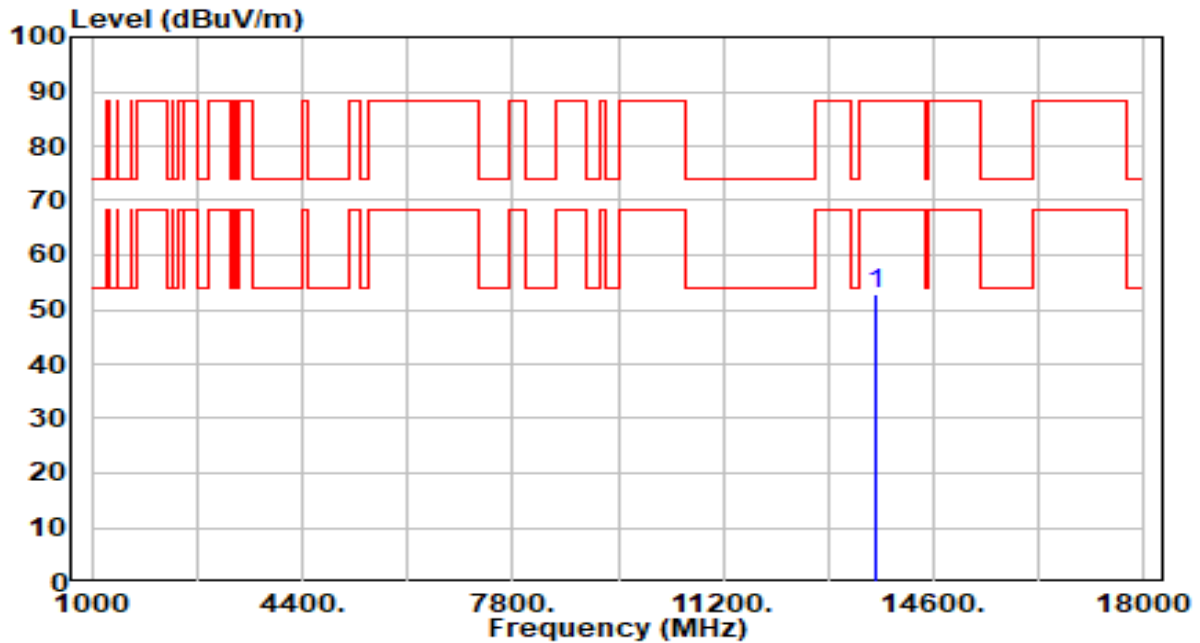

No	Frequency (MHz)	Reading (dBuV)	C.F (dB/m)	Measurement (dBuV/m)	Margin (dB)	Limit (dBuV/m)	Height (cm)	Angle (deg)	Remark (QP/PK/AV)
1	*	46.15	6.53	52.67	-35.53	88.20	200	58	Peak

Note:

- "*", means this data is the worst emission level.
- C.F (Correction Factor) = Antenna Factor (dB/m)+ Cable Loss (dB) – Preamplifier(dB).
- Measurement (dBuV/m) = Reading(dBuV) + C.F (Correction Factor).
- The emission levels of other frequencies are very lower than the limit and not show in test report.

EUT	BE11000 Tri-Band Wi-Fi 7 Gaming Router	Date of Test	2024-01-16
Factor	DRH18-E	Temp. / Humidity	21°C /63%
Polarity	Horizontal	Site / Test Engineer	AC2 / Stanley
Test Mode	802.11ax-160MHz_TX_Band8_CH 207_ANT 0+1 Nss2	Test Voltage	AC 120V/60Hz

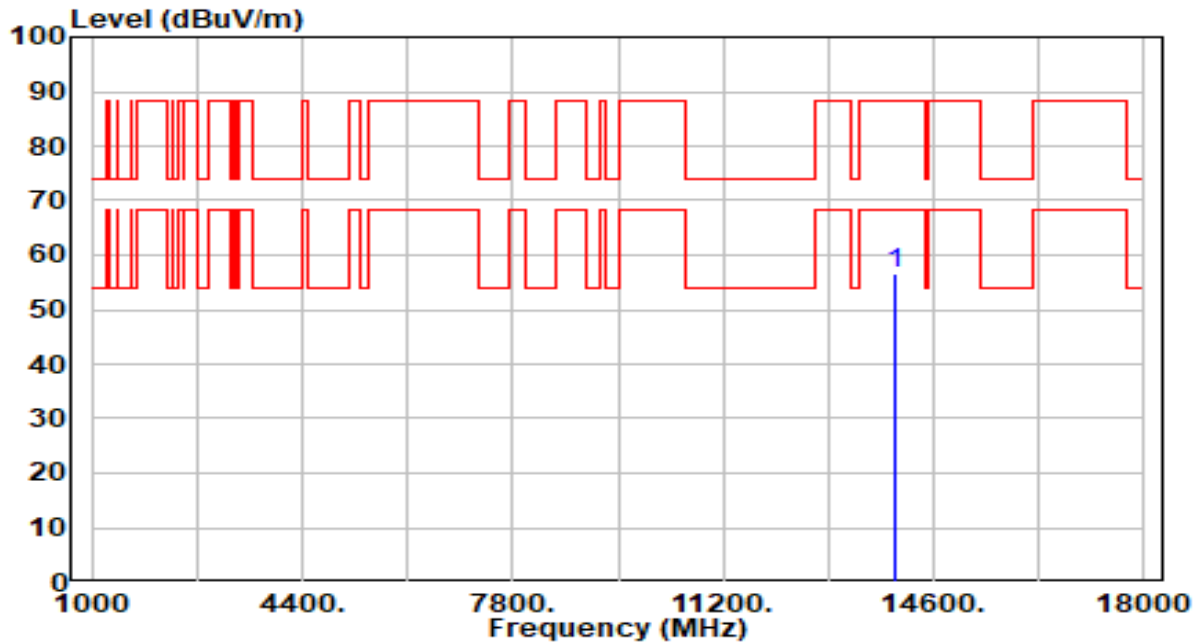

No	Frequency (MHz)	Reading (dBuV)	C.F (dB/m)	Measurement (dBuV/m)	Margin (dB)	Limit (dBuV/m)	Height (cm)	Angle (deg)	Remark (QP/PK/AV)
1	* 13970.000	49.98	6.61	56.59	-31.61	88.20	200	227	Peak

Note:

- "*", means this data is the worst emission level.
- C.F (Correction Factor) = Antenna Factor (dB/m)+ Cable Loss (dB) – Preamplifier(dB).
- Measurement (dBuV/m) = Reading(dBuV) + C.F (Correction Factor).
- The emission levels of other frequencies are very lower than the limit and not show in test report.

EUT	BE11000 Tri-Band Wi-Fi 7 Gaming Router	Date of Test	2024-01-16
Factor	DRH18-E	Temp. / Humidity	21°C /63%
Polarity	Vertical	Site / Test Engineer	AC2 / Stanley
Test Mode	802.11ax-160MHz_TX_Band8_CH 207_ANT 0+1 Nss2	Test Voltage	AC 120V/60Hz

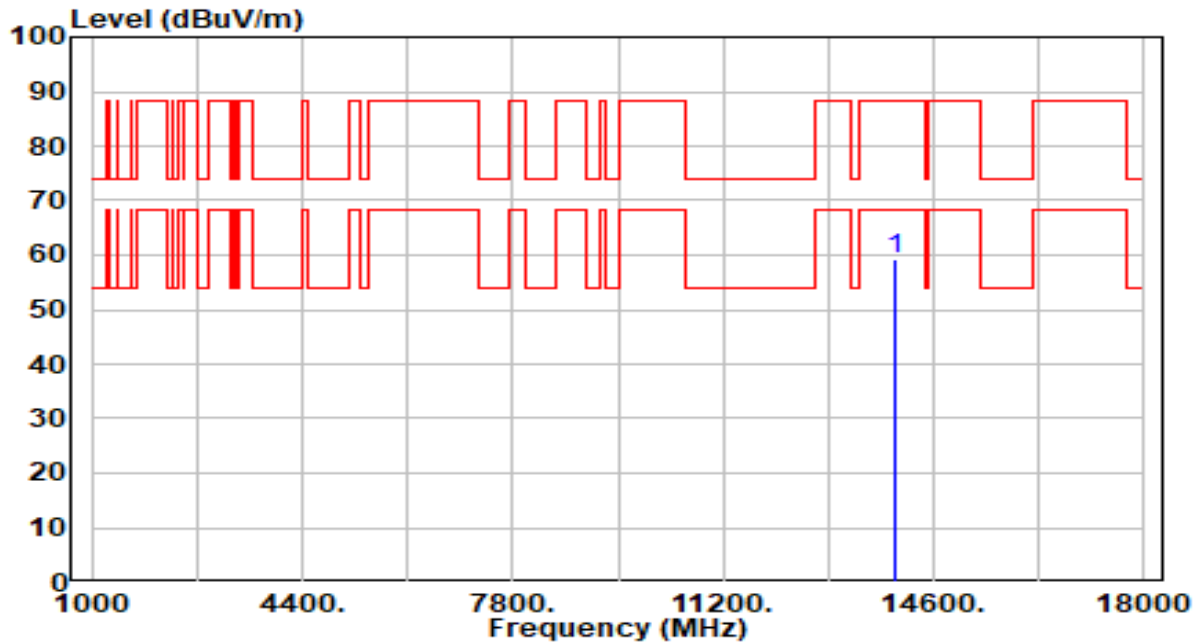

No	Frequency (MHz)	Reading (dBuV)	C.F (dB/m)	Measurement (dBuV/m)	Margin (dB)	Limit (dBuV/m)	Height (cm)	Angle (deg)	Remark (QP/PK/AV)
1	* 13970.000	52.80	6.61	59.41	-28.79	88.20	200	56	Peak

Note:

1. " *", means this data is the worst emission level.
2. C.F (Correction Factor) = Antenna Factor (dB/m)+ Cable Loss (dB) – Preamplifier(dB).
3. Measurement (dBuV/m) = Reading(dBuV) + C.F (Correction Factor).
4. The emission levels of other frequencies are very lower than the limit and not show in test report.

EUT	BE11000 Tri-Band Wi-Fi 7 Gaming Router	Date of Test	2024-01-16
Factor	DRH18-E	Temp. / Humidity	21°C /63%
Polarity	Horizontal	Site / Test Engineer	AC2 / Stanley
Test Mode	802.11be-20MHz_TX_Band5_CH 1_ANT 0+1 Nss2	Test Voltage	AC 120V/60Hz

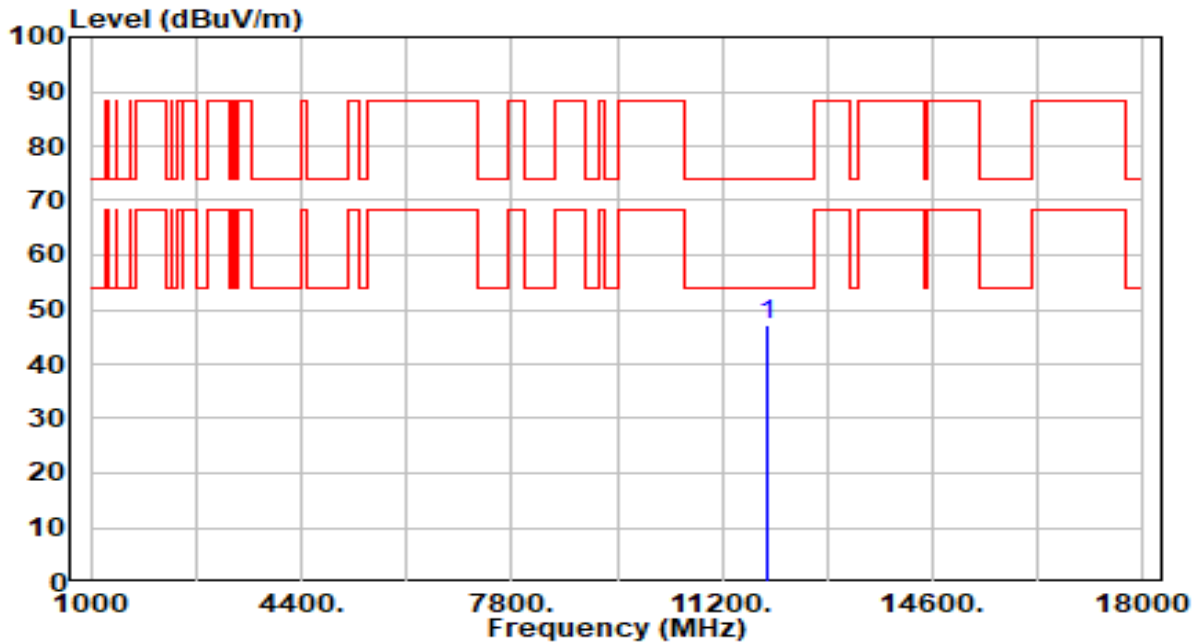

No	Frequency (MHz)	Reading (dBuV)	C.F (dB/m)	Measurement (dBuV/m)	Margin (dB)	Limit (dBuV/m)	Height (cm)	Angle (deg)	Remark (QP/PK/AV)
1	*	41.88	5.39	47.27	-26.73	74.00	200	194	Peak

Note:

1. " *", means this data is the worst emission level.
2. C.F (Correction Factor) = Antenna Factor (dB/m)+ Cable Loss (dB) – Preamplifier(dB).
3. Measurement (dBuV/m) = Reading(dBuV) + C.F (Correction Factor).
4. The emission levels of other frequencies are very lower than the limit and not show in test report.

EUT	BE11000 Tri-Band Wi-Fi 7 Gaming Router	Date of Test	2024-01-16
Factor	DRH18-E	Temp. / Humidity	21°C /63%
Polarity	Vertical	Site / Test Engineer	AC2 / Stanley
Test Mode	802.11be-20MHz_TX_Band5_CH 1_ANT 0+1 Nss2	Test Voltage	AC 120V/60Hz

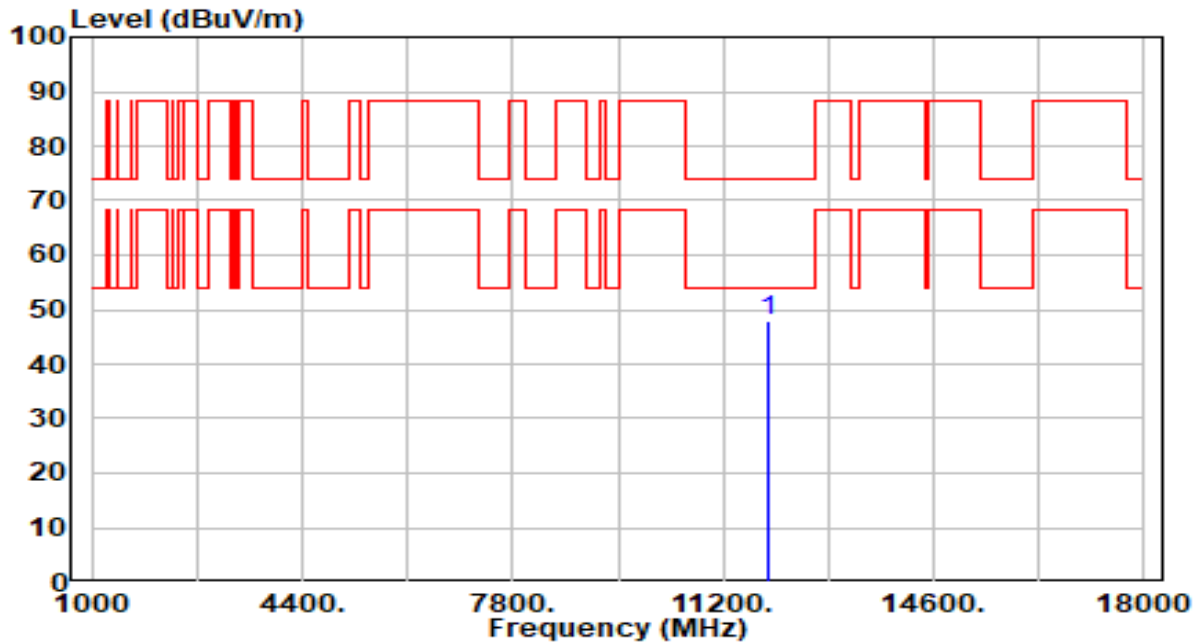

No	Frequency (MHz)	Reading (dBuV)	C.F (dB/m)	Measurement (dBuV/m)	Margin (dB)	Limit (dBuV/m)	Height (cm)	Angle (deg)	Remark (QP/PK/AV)
1	*	42.45	5.39	47.84	-26.16	74.00	200	154	Peak

Note:

1. " *", means this data is the worst emission level.
2. C.F (Correction Factor) = Antenna Factor (dB/m)+ Cable Loss (dB) – Preamplifier(dB).
3. Measurement (dBuV/m) = Reading(dBuV) + C.F (Correction Factor).
4. The emission levels of other frequencies are very lower than the limit and not show in test report.

EUT	BE11000 Tri-Band Wi-Fi 7 Gaming Router	Date of Test	2024-01-16
Factor	DRH18-E	Temp. / Humidity	21°C /63%
Polarity	Horizontal	Site / Test Engineer	AC2 / Stanley
Test Mode	802.11be-20MHz_TX_Band5_CH 45_ANT 0+1	Test Voltage	AC 120V/60Hz

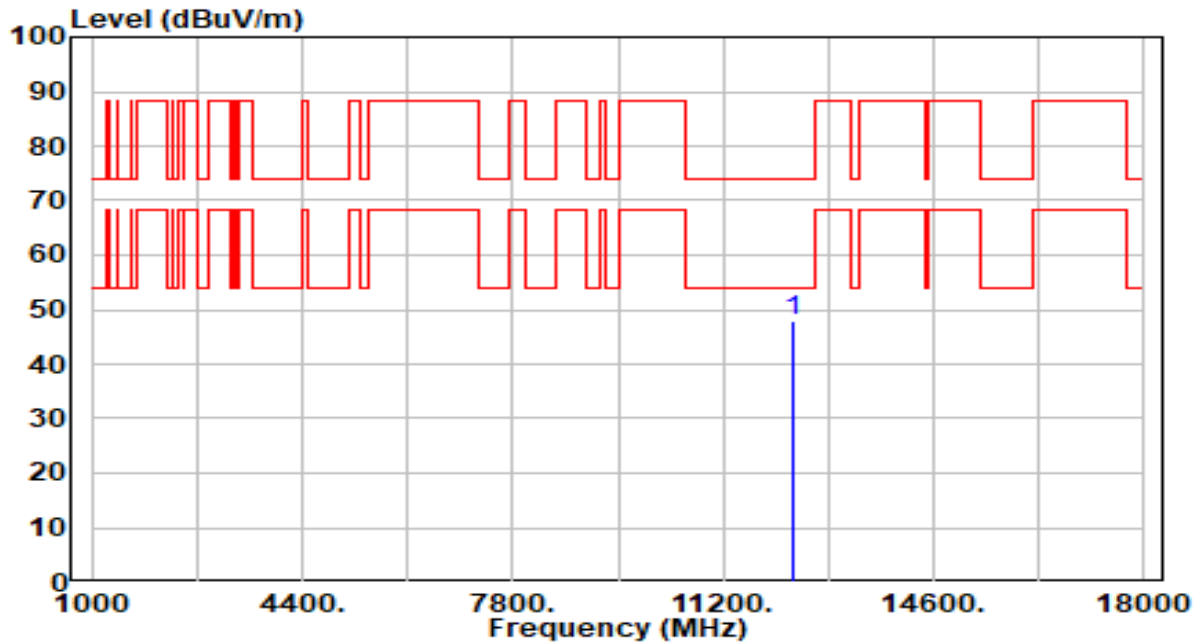

No	Frequency (MHz)	Reading (dBuV)	C.F (dB/m)	Measurement (dBuV/m)	Margin (dB)	Limit (dBuV/m)	Height (cm)	Angle (deg)	Remark (QP/PK/AV)
1	*	41.77	6.09	47.87	-26.13	74.00	200	327	Peak

Note:

- "*", means this data is the worst emission level.
- C.F (Correction Factor) = Antenna Factor (dB/m)+ Cable Loss (dB) – Preamplifier(dB).
- Measurement (dBuV/m) = Reading(dBuV) + C.F (Correction Factor).
- The emission levels of other frequencies are very lower than the limit and not show in test report.

EUT	BE11000 Tri-Band Wi-Fi 7 Gaming Router	Date of Test	2024-01-16
Factor	DRH18-E	Temp. / Humidity	21°C /63%
Polarity	Vertical	Site / Test Engineer	AC2 / Stanley
Test Mode	802.11be-20MHz_TX_Band5_CH 45_ANT 0+1	Test Voltage	AC 120V/60Hz

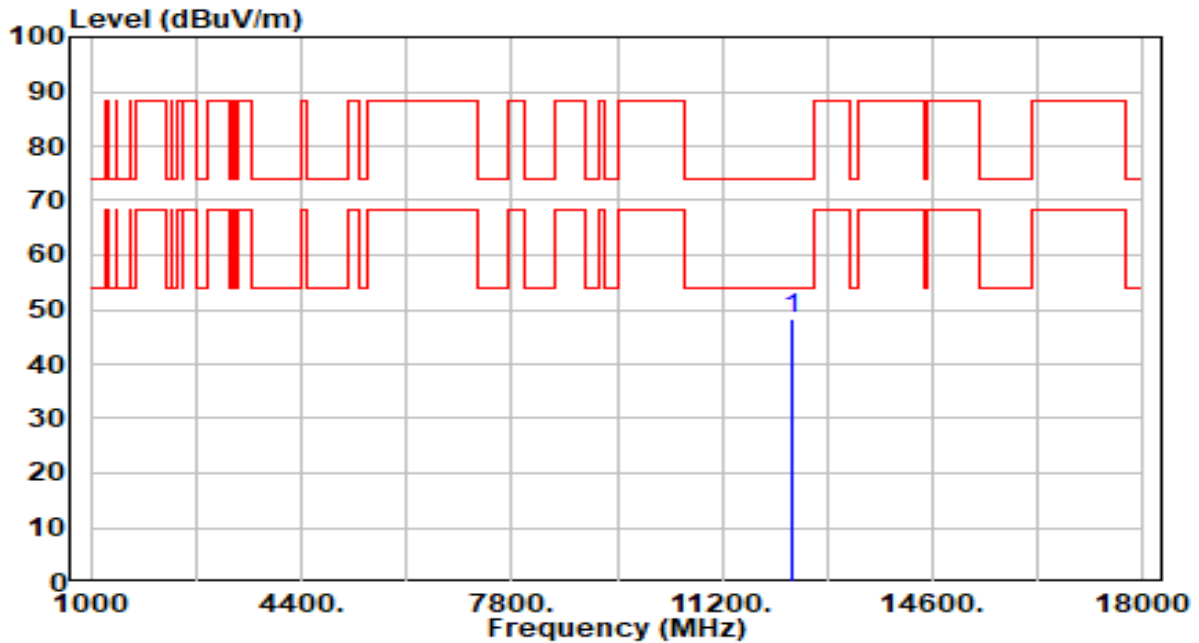

No	Frequency (MHz)	Reading (dBuV)	C.F (dB/m)	Measurement (dBuV/m)	Margin (dB)	Limit (dBuV/m)	Height (cm)	Angle (deg)	Remark (QP/PK/AV)
1	*	42.26	6.09	48.35	-25.65	74.00	200	259	Peak

Note:

- "*", means this data is the worst emission level.
- C.F (Correction Factor) = Antenna Factor (dB/m)+ Cable Loss (dB) – Preamplifier(dB).
- Measurement (dBuV/m) = Reading(dBuV) + C.F (Correction Factor).
- The emission levels of other frequencies are very lower than the limit and not show in test report.

EUT	BE11000 Tri-Band Wi-Fi 7 Gaming Router	Date of Test	2024-01-16
Factor	DRH18-E	Temp. / Humidity	21°C /63%
Polarity	Horizontal	Site / Test Engineer	AC2 / Stanley
Test Mode	802.11be-20MHz_TX_Band5_CH 93_ANT 0+1 Nss2	Test Voltage	AC 120V/60Hz

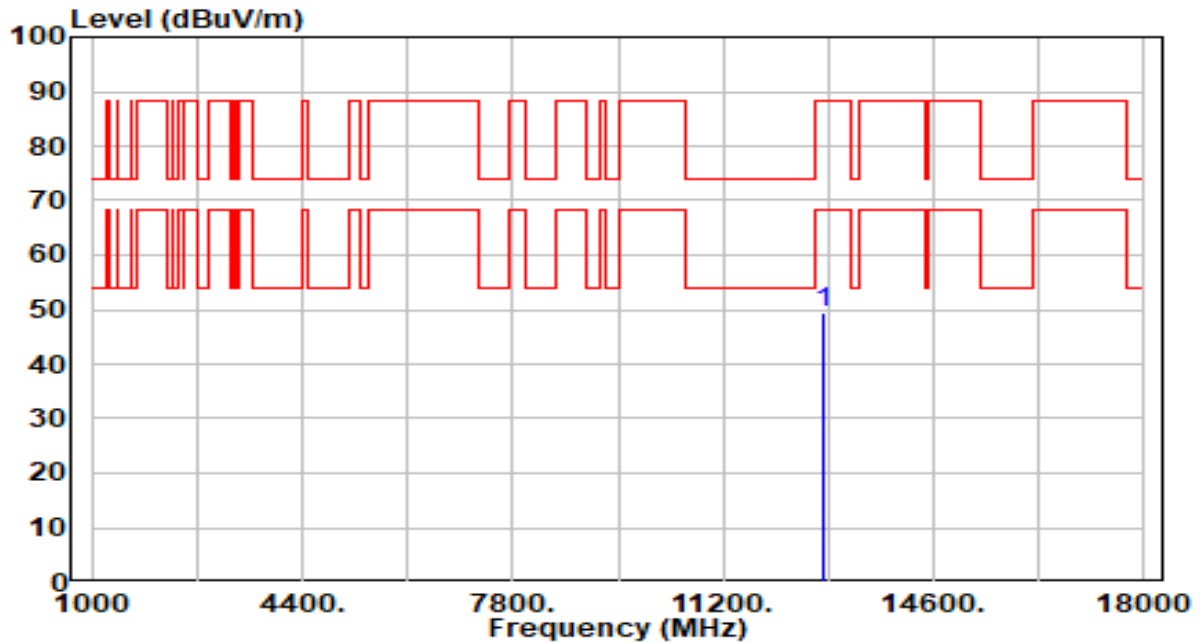

No	Frequency (MHz)	Reading (dBuV)	C.F (dB/m)	Measurement (dBuV/m)	Margin (dB)	Limit (dBuV/m)	Height (cm)	Angle (deg)	Remark (QP/PK/AV)
1	*	42.44	6.92	49.36	-38.84	88.20	200	126	Peak

Note:

- "*", means this data is the worst emission level.
- C.F (Correction Factor) = Antenna Factor (dB/m)+ Cable Loss (dB) – Preamplifier(dB).
- Measurement (dBuV/m) = Reading(dBuV) + C.F (Correction Factor).
- The emission levels of other frequencies are very lower than the limit and not show in test report.

EUT	BE11000 Tri-Band Wi-Fi 7 Gaming Router	Date of Test	2024-01-16
Factor	DRH18-E	Temp. / Humidity	21°C /63%
Polarity	Vertical	Site / Test Engineer	AC2 / Stanley
Test Mode	802.11be-20MHz_TX_Band5_CH 93_ANT 0+1 Nss2	Test Voltage	AC 120V/60Hz

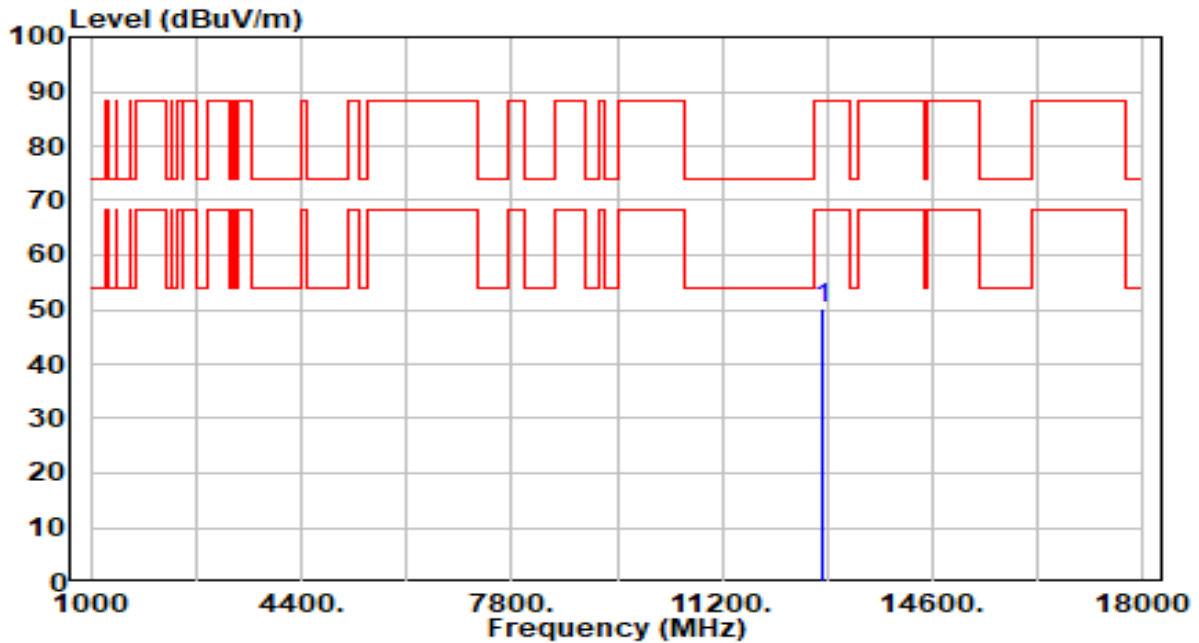

No	Frequency (MHz)	Reading (dBuV)	C.F (dB/m)	Measurement (dBuV/m)	Margin (dB)	Limit (dBuV/m)	Height (cm)	Angle (deg)	Remark (QP/PK/AV)
1	*	43.24	6.92	50.16	-38.04	88.20	200	343	Peak

Note:

- "*", means this data is the worst emission level.
- C.F (Correction Factor) = Antenna Factor (dB/m)+ Cable Loss (dB) – Preamplifier(dB).
- Measurement (dBuV/m) = Reading(dBuV) + C.F (Correction Factor).
- The emission levels of other frequencies are very lower than the limit and not show in test report.

EUT	BE11000 Tri-Band Wi-Fi 7 Gaming Router	Date of Test	2024-01-16
Factor	DRH18-E	Temp. / Humidity	21°C /63%
Polarity	Horizontal	Site / Test Engineer	AC2 / Stanley
Test Mode	802.11be-20MHz_TX_Band6_CH 97_ANT 0+1 Nss2	Test Voltage	AC 120V/60Hz

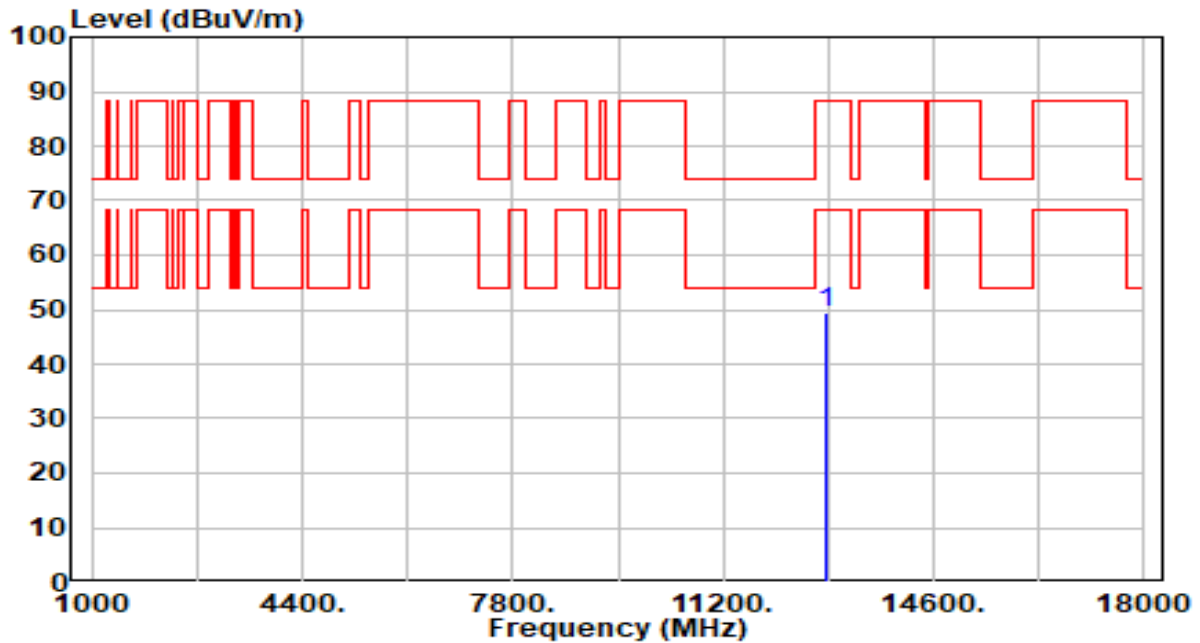

No	Frequency (MHz)	Reading (dBuV)	C.F (dB/m)	Measurement (dBuV/m)	Margin (dB)	Limit (dBuV/m)	Height (cm)	Angle (deg)	Remark (QP/PK/AV)
1	*	42.72	6.91	49.62	-38.58	88.20	200	31	Peak

Note:

- "*", means this data is the worst emission level.
- C.F (Correction Factor) = Antenna Factor (dB/m)+ Cable Loss (dB) – Preamplifier(dB).
- Measurement (dBuV/m) = Reading(dBuV) + C.F (Correction Factor).
- The emission levels of other frequencies are very lower than the limit and not show in test report.

EUT	BE11000 Tri-Band Wi-Fi 7 Gaming Router	Date of Test	2024-01-16
Factor	DRH18-E	Temp. / Humidity	21°C /63%
Polarity	Vertical	Site / Test Engineer	AC2 / Stanley
Test Mode	802.11be-20MHz_TX_Band6_CH 97_ANT 0+1 Nss2	Test Voltage	AC 120V/60Hz

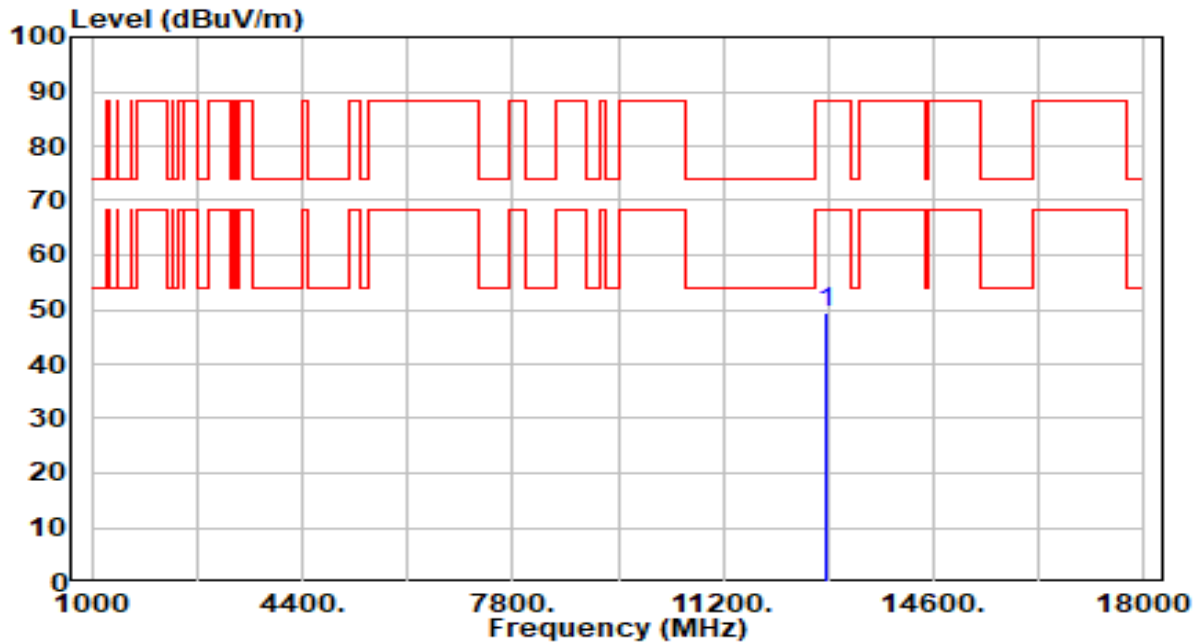

No	Frequency (MHz)	Reading (dBuV)	C.F (dB/m)	Measurement (dBuV/m)	Margin (dB)	Limit (dBuV/m)	Height (cm)	Angle (deg)	Remark (QP/PK/AV)
1	*	42.71	6.91	49.61	-38.59	88.20	200	21	Peak

Note:

1. " *", means this data is the worst emission level.
2. C.F (Correction Factor) = Antenna Factor (dB/m)+ Cable Loss (dB) – Preamplifier(dB).
3. Measurement (dBuV/m) = Reading(dBuV) + C.F (Correction Factor).
4. The emission levels of other frequencies are very lower than the limit and not show in test report.

EUT	BE11000 Tri-Band Wi-Fi 7 Gaming Router	Date of Test	2024-01-16
Factor	DRH18-E	Temp. / Humidity	21°C /63%
Polarity	Horizontal	Site / Test Engineer	AC2 / Stanley
Test Mode	802.11be-20MHz_TX_Band6_CH 105_ANT 0+1 Nss2	Test Voltage	AC 120V/60Hz

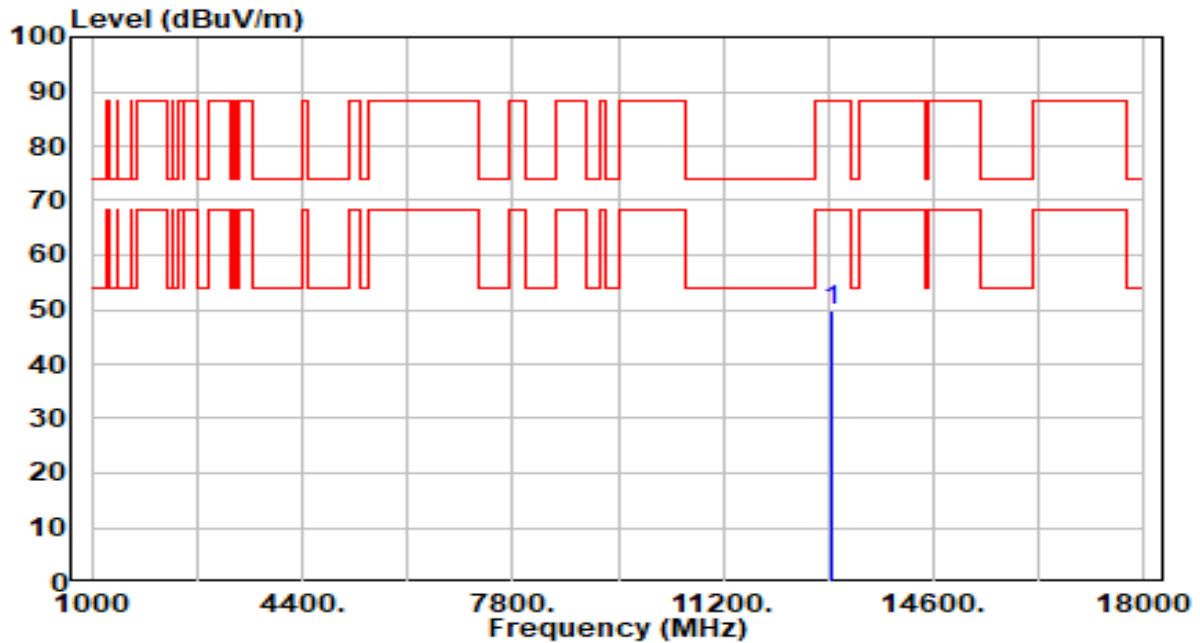

No	Frequency (MHz)	Reading (dBuV)	C.F (dB/m)	Measurement (dBuV/m)	Margin (dB)	Limit (dBuV/m)	Height (cm)	Angle (deg)	Remark (QP/PK/AV)
1	*	43.10	6.88	49.98	-38.22	88.20	200	358	Peak

Note:

- "*", means this data is the worst emission level.
- C.F (Correction Factor) = Antenna Factor (dB/m)+ Cable Loss (dB) – Preamplifier(dB).
- Measurement (dBuV/m) = Reading(dBuV) + C.F (Correction Factor).
- The emission levels of other frequencies are very lower than the limit and not show in test report.

EUT	BE11000 Tri-Band Wi-Fi 7 Gaming Router	Date of Test	2024-01-16
Factor	DRH18-E	Temp. / Humidity	21°C /63%
Polarity	Vertical	Site / Test Engineer	AC2 / Stanley
Test Mode	802.11be-20MHz_TX_Band6_CH 105_ANT 0+1 Nss2	Test Voltage	AC 120V/60Hz

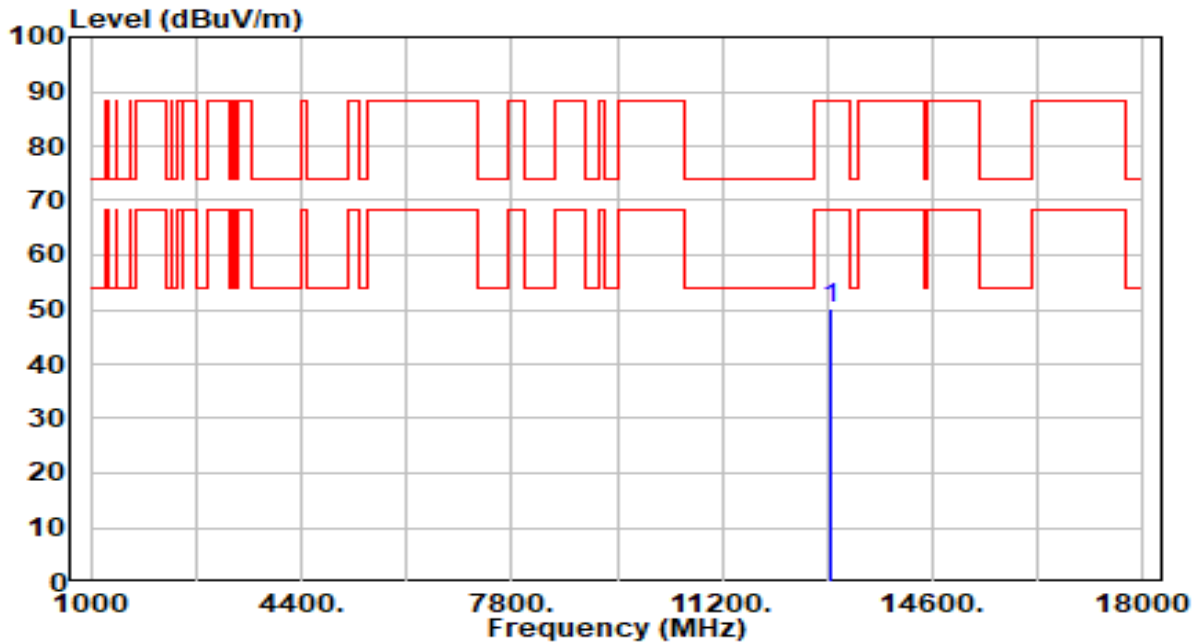

No	Frequency (MHz)	Reading (dBuV)	C.F (dB/m)	Measurement (dBuV/m)	Margin (dB)	Limit (dBuV/m)	Height (cm)	Angle (deg)	Remark (QP/PK/AV)
1	*	43.15	6.88	50.03	-38.17	88.20	200	317	Peak

Note:

- "*", means this data is the worst emission level.
- C.F (Correction Factor) = Antenna Factor (dB/m)+ Cable Loss (dB) – Preamplifier(dB).
- Measurement (dBuV/m) = Reading(dBuV) + C.F (Correction Factor).
- The emission levels of other frequencies are very lower than the limit and not show in test report.

EUT	BE11000 Tri-Band Wi-Fi 7 Gaming Router	Date of Test	2024-01-16
Factor	DRH18-E	Temp. / Humidity	21°C /63%
Polarity	Horizontal	Site / Test Engineer	AC2 / Stanley
Test Mode	802.11be-20MHz_TX_Band6_CH 113_ANT 0+1 Nss2	Test Voltage	AC 120V/60Hz

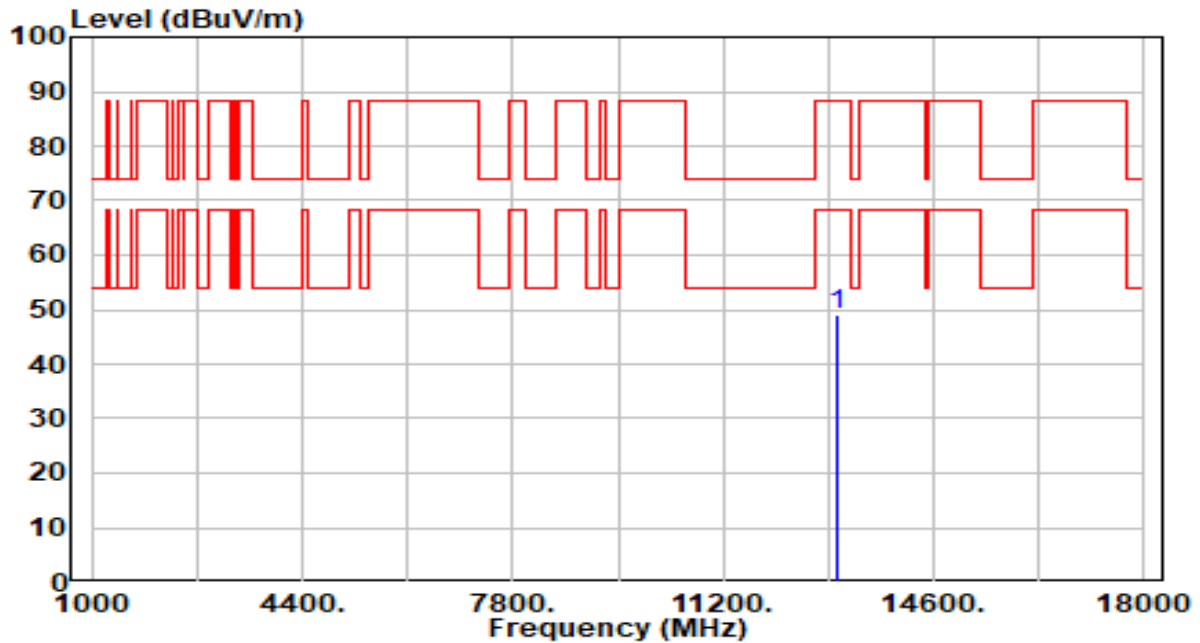

No	Frequency (MHz)	Reading (dBuV)	C.F (dB/m)	Measurement (dBuV/m)	Margin (dB)	Limit (dBuV/m)	Height (cm)	Angle (deg)	Remark (QP/PK/AV)
1	*	42.08	6.86	48.94	-39.26	88.20	200	158	Peak

Note:

- "*", means this data is the worst emission level.
- C.F (Correction Factor) = Antenna Factor (dB/m)+ Cable Loss (dB) – Preamplifier(dB).
- Measurement (dBuV/m) = Reading(dBuV) + C.F (Correction Factor).
- The emission levels of other frequencies are very lower than the limit and not show in test report.

EUT	BE11000 Tri-Band Wi-Fi 7 Gaming Router	Date of Test	2024-01-16
Factor	DRH18-E	Temp. / Humidity	21°C /63%
Polarity	Vertical	Site / Test Engineer	AC2 / Stanley
Test Mode	802.11be-20MHz_TX_Band6_CH 113_ANT 0+1 Nss2	Test Voltage	AC 120V/60Hz

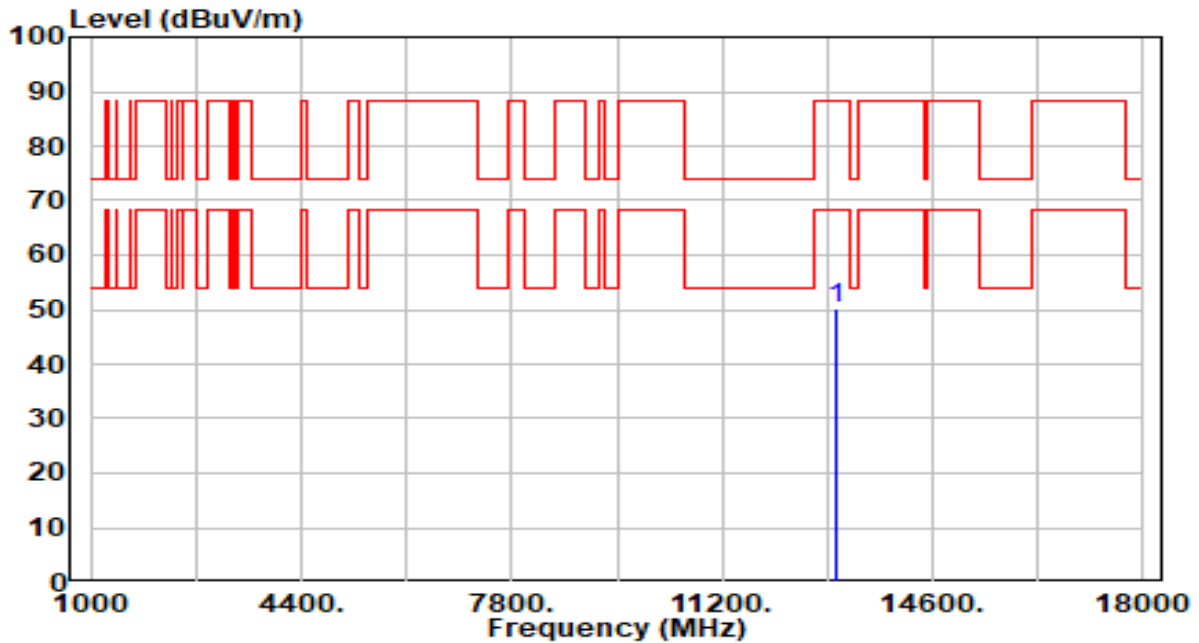

No	Frequency (MHz)	Reading (dBuV)	C.F (dB/m)	Measurement (dBuV/m)	Margin (dB)	Limit (dBuV/m)	Height (cm)	Angle (deg)	Remark (QP/PK/AV)
1	* 13030.000	43.16	6.86	50.01	-38.19	88.20	200	202	Peak

Note:

1. " *", means this data is the worst emission level.
2. C.F (Correction Factor) = Antenna Factor (dB/m)+ Cable Loss (dB) – Preamplifier(dB).
3. Measurement (dBuV/m) = Reading(dBuV) + C.F (Correction Factor).
4. The emission levels of other frequencies are very lower than the limit and not show in test report.

EUT	BE11000 Tri-Band Wi-Fi 7 Gaming Router	Date of Test	2024-01-16
Factor	DRH18-E	Temp. / Humidity	21°C /63%
Polarity	Horizontal	Site / Test Engineer	AC2 / Stanley
Test Mode	802.11be-20MHz_TX_Band7_CH 117_ANT 0+1 Nss2	Test Voltage	AC 120V/60Hz

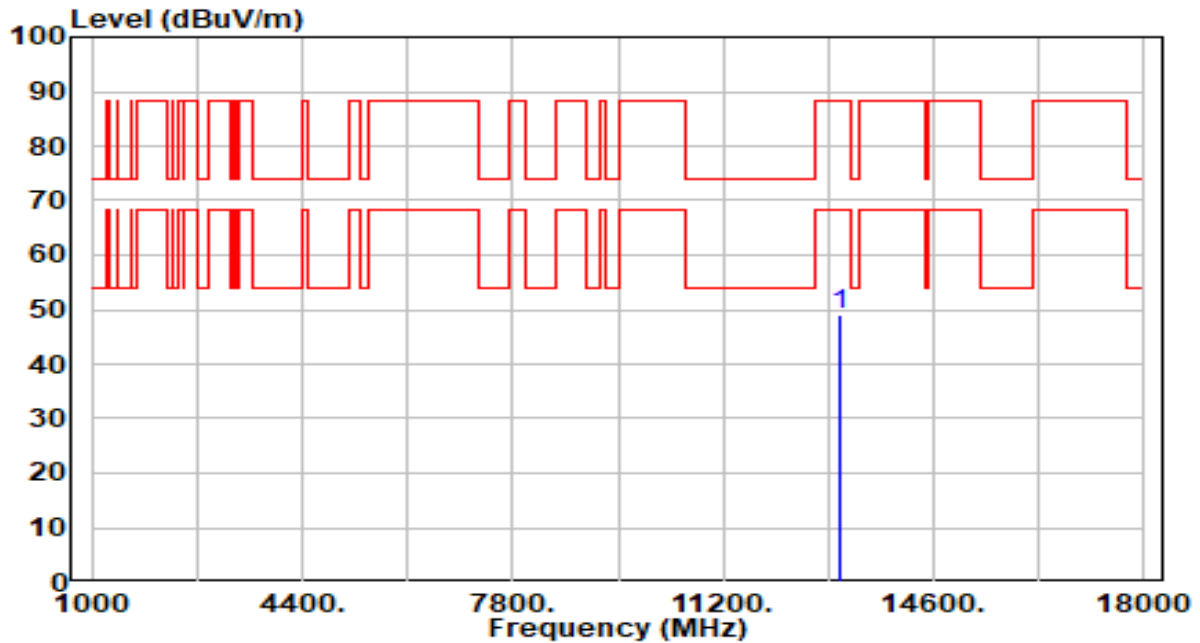

No	Frequency (MHz)	Reading (dBuV)	C.F (dB/m)	Measurement (dBuV/m)	Margin (dB)	Limit (dBuV/m)	Height (cm)	Angle (deg)	Remark (QP/PK/AV)
1	*	42.12	6.84	48.97	-39.23	88.20	200	198	Peak

Note:

- "*", means this data is the worst emission level.
- C.F (Correction Factor) = Antenna Factor (dB/m)+ Cable Loss (dB) – Preamplifier(dB).
- Measurement (dBuV/m) = Reading(dBuV) + C.F (Correction Factor).
- The emission levels of other frequencies are very lower than the limit and not show in test report.

EUT	BE11000 Tri-Band Wi-Fi 7 Gaming Router	Date of Test	2024-01-16
Factor	DRH18-E	Temp. / Humidity	21°C /63%
Polarity	Vertical	Site / Test Engineer	AC2 / Stanley
Test Mode	802.11be-20MHz_TX_Band7_CH 117_ANT 0+1 Nss2	Test Voltage	AC 120V/60Hz

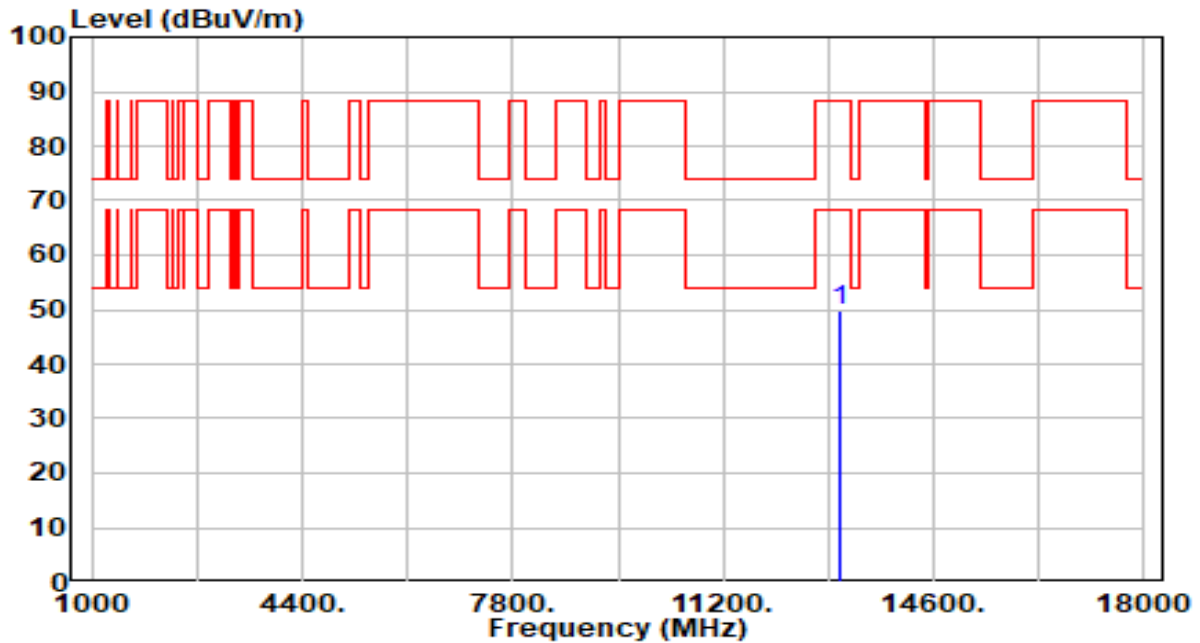

No	Frequency (MHz)	Reading (dBuV)	C.F (dB/m)	Measurement (dBuV/m)	Margin (dB)	Limit (dBuV/m)	Height (cm)	Angle (deg)	Remark (QP/PK/AV)
1	* 13070.000	43.11	6.84	49.95	-38.25	88.20	200	131	Peak

Note:

- "*", means this data is the worst emission level.
- C.F (Correction Factor) = Antenna Factor (dB/m)+ Cable Loss (dB) – Preamplifier(dB).
- Measurement (dBuV/m) = Reading(dBuV) + C.F (Correction Factor).
- The emission levels of other frequencies are very lower than the limit and not show in test report.

EUT	BE11000 Tri-Band Wi-Fi 7 Gaming Router	Date of Test	2024-01-16
Factor	DRH18-E	Temp. / Humidity	21°C /63%
Polarity	Horizontal	Site / Test Engineer	AC2 / Stanley
Test Mode	802.11be-20MHz_TX_Band7_CH 149_ANT 0+1 Nss2	Test Voltage	AC 120V/60Hz

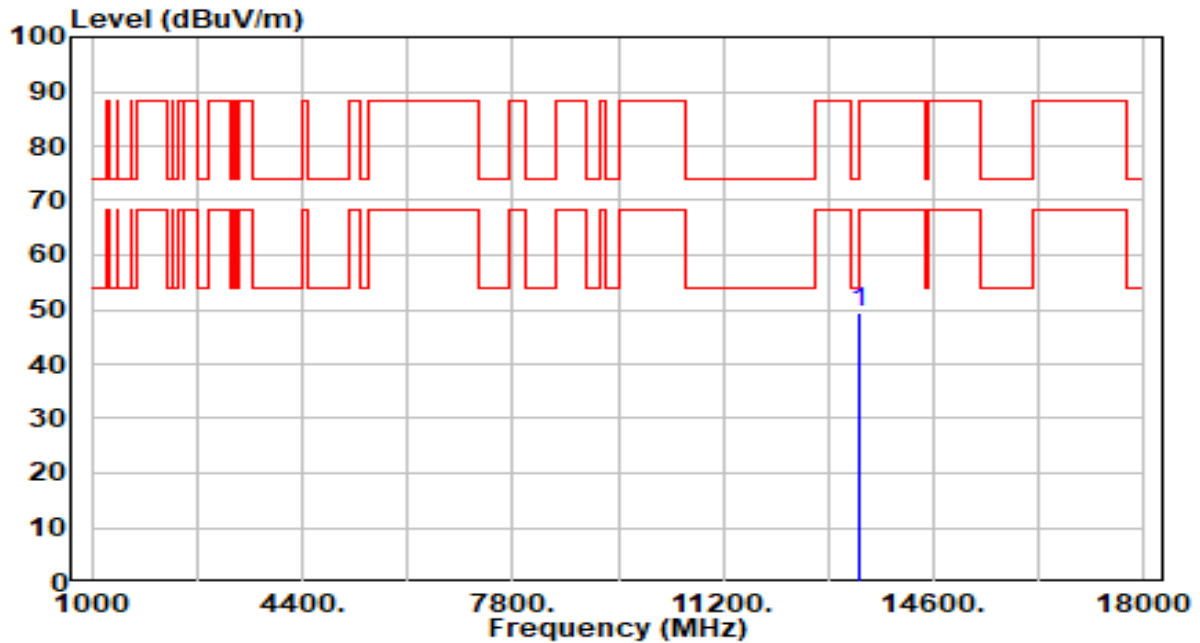

No	Frequency (MHz)	Reading (dBuV)	C.F (dB/m)	Measurement (dBuV/m)	Margin (dB)	Limit (dBuV/m)	Height (cm)	Angle (deg)	Remark (QP/PK/AV)
1	*	42.75	6.82	49.56	-24.44	74.00	200	204	Peak

Note:

- "*", means this data is the worst emission level.
- C.F (Correction Factor) = Antenna Factor (dB/m)+ Cable Loss (dB) – Preamplifier(dB).
- Measurement (dBuV/m) = Reading(dBuV) + C.F (Correction Factor).
- The emission levels of other frequencies are very lower than the limit and not show in test report.

EUT	BE11000 Tri-Band Wi-Fi 7 Gaming Router	Date of Test	2024-01-16
Factor	DRH18-E	Temp. / Humidity	21°C /63%
Polarity	Vertical	Site / Test Engineer	AC2 / Stanley
Test Mode	802.11be-20MHz_TX_Band7_CH 149_ANT 0+1 Nss2	Test Voltage	AC 120V/60Hz

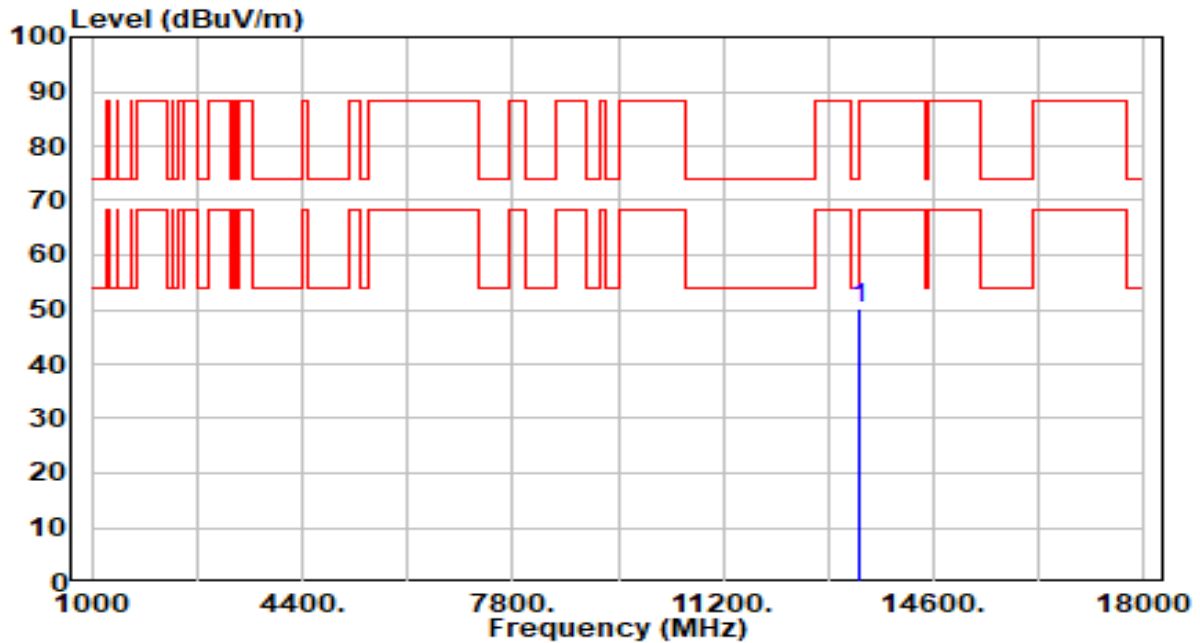

No	Frequency (MHz)	Reading (dBuV)	C.F (dB/m)	Measurement (dBuV/m)	Margin (dB)	Limit (dBuV/m)	Height (cm)	Angle (deg)	Remark (QP/PK/AV)
1	*	43.30	6.82	50.12	-23.88	74.00	200	165	Peak

Note:

- "*", means this data is the worst emission level.
- C.F (Correction Factor) = Antenna Factor (dB/m)+ Cable Loss (dB) – Preamplifier(dB).
- Measurement (dBuV/m) = Reading(dBuV) + C.F (Correction Factor).
- The emission levels of other frequencies are very lower than the limit and not show in test report.

EUT	BE11000 Tri-Band Wi-Fi 7 Gaming Router	Date of Test	2024-01-16
Factor	DRH18-E	Temp. / Humidity	21°C /63%
Polarity	Horizontal	Site / Test Engineer	AC2 / Stanley
Test Mode	802.11be-20MHz_TX_Band7_CH 181_ANT 0+1 Nss2	Test Voltage	AC 120V/60Hz

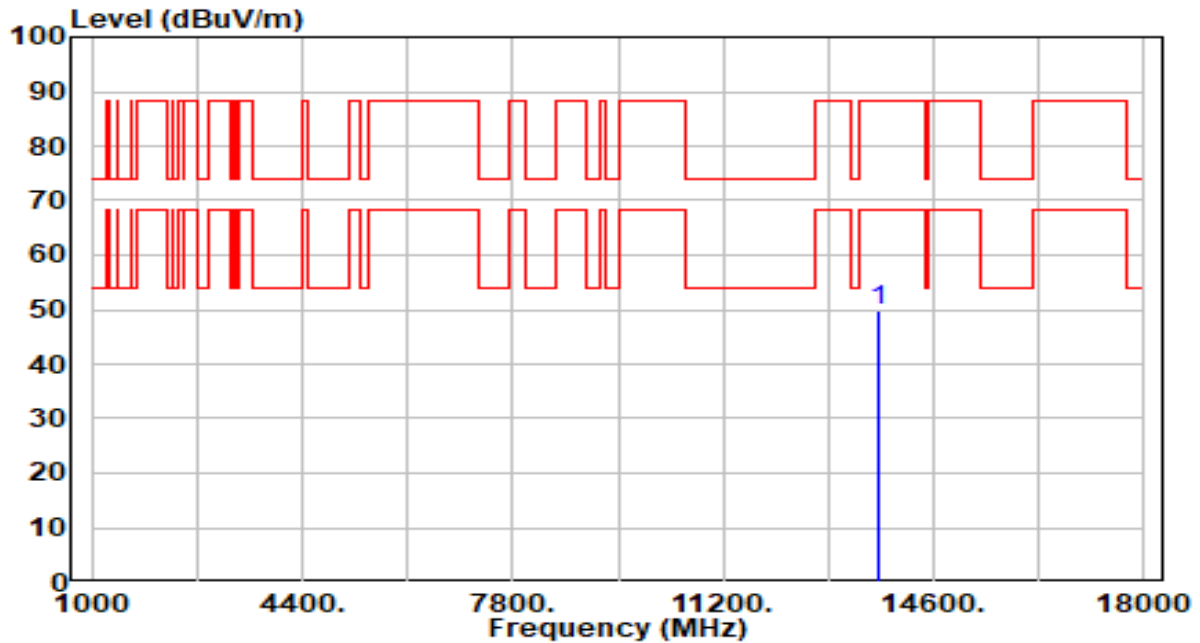

No	Frequency (MHz)	Reading (dBuV)	C.F (dB/m)	Measurement (dBuV/m)	Margin (dB)	Limit (dBuV/m)	Height (cm)	Angle (deg)	Remark (QP/PK/AV)
1	*	43.27	6.53	49.80	-38.40	88.20	200	223	Peak

Note:

1. " *", means this data is the worst emission level.
2. C.F (Correction Factor) = Antenna Factor (dB/m)+ Cable Loss (dB) – Preamplifier(dB).
3. Measurement (dBuV/m) = Reading(dBuV) + C.F (Correction Factor).
4. The emission levels of other frequencies are very lower than the limit and not show in test report.

EUT	BE11000 Tri-Band Wi-Fi 7 Gaming Router	Date of Test	2024-01-16
Factor	DRH18-E	Temp. / Humidity	21°C /63%
Polarity	Vertical	Site / Test Engineer	AC2 / Stanley
Test Mode	802.11be-20MHz_TX_Band7_CH 181_ANT 0+1 Nss2	Test Voltage	AC 120V/60Hz

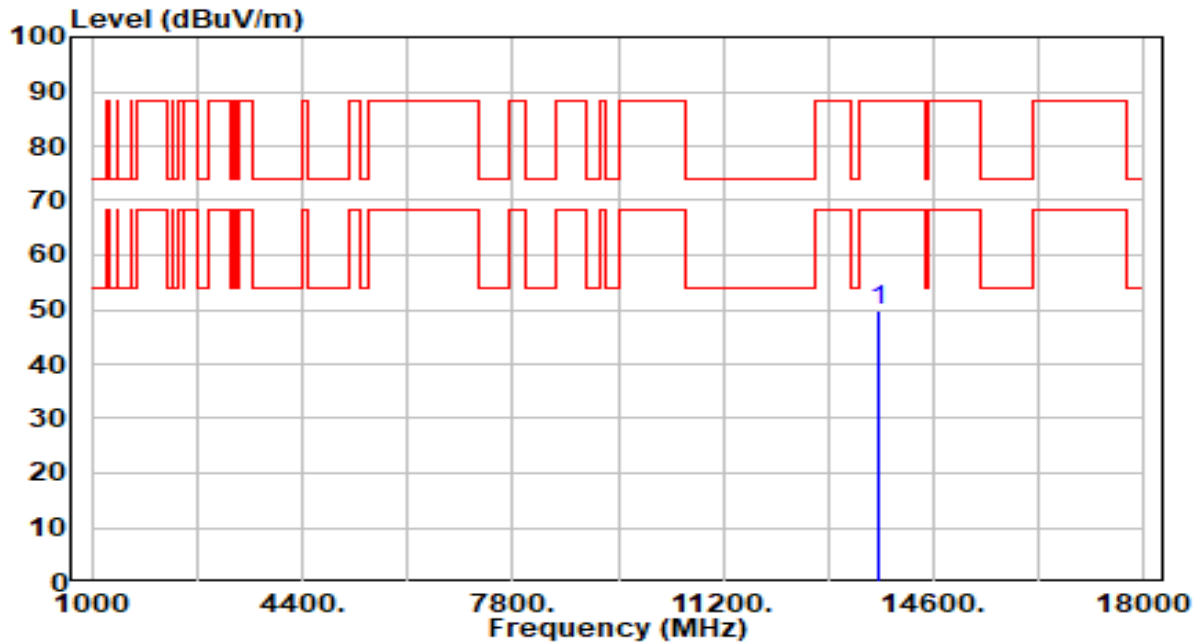

No	Frequency (MHz)	Reading (dBuV)	C.F (dB/m)	Measurement (dBuV/m)	Margin (dB)	Limit (dBuV/m)	Height (cm)	Angle (deg)	Remark (QP/PK/AV)
1	* 13710.000	43.17	6.53	49.69	-38.51	88.20	200	114	Peak

Note:

- "*", means this data is the worst emission level.
- C.F (Correction Factor) = Antenna Factor (dB/m)+ Cable Loss (dB) – Preamplifier(dB).
- Measurement (dBuV/m) = Reading(dBuV) + C.F (Correction Factor).
- The emission levels of other frequencies are very lower than the limit and not show in test report.

EUT	BE11000 Tri-Band Wi-Fi 7 Gaming Router	Date of Test	2024-01-16
Factor	DRH18-E	Temp. / Humidity	21°C /63%
Polarity	Horizontal	Site / Test Engineer	AC2 / Stanley
Test Mode	802.11be-20MHz_TX_Band6_CH 185_ANT 0+1 Nss2	Test Voltage	AC 120V/60Hz

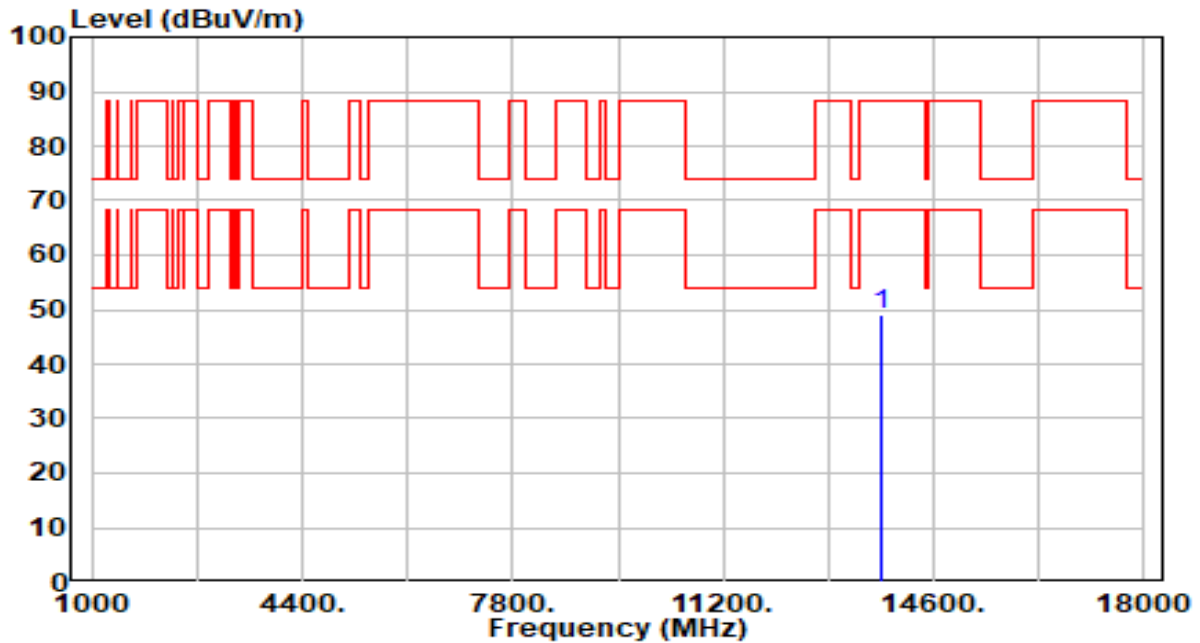

No	Frequency (MHz)	Reading (dBuV)	C.F (dB/m)	Measurement (dBuV/m)	Margin (dB)	Limit (dBuV/m)	Height (cm)	Angle (deg)	Remark (QP/PK/AV)
1	*	42.66	6.53	49.18	-39.02	88.20	200	212	Peak

Note:

1. " *", means this data is the worst emission level.
2. C.F (Correction Factor) = Antenna Factor (dB/m)+ Cable Loss (dB) – Preamplifier(dB).
3. Measurement (dBuV/m) = Reading(dBuV) + C.F (Correction Factor).
4. The emission levels of other frequencies are very lower than the limit and not show in test report.

EUT	BE11000 Tri-Band Wi-Fi 7 Gaming Router	Date of Test	2024-01-16
Factor	DRH18-E	Temp. / Humidity	21°C /63%
Polarity	Vertical	Site / Test Engineer	AC2 / Stanley
Test Mode	802.11be-20MHz_TX_Band6_CH 185_ANT 0+1 Nss2	Test Voltage	AC 120V/60Hz

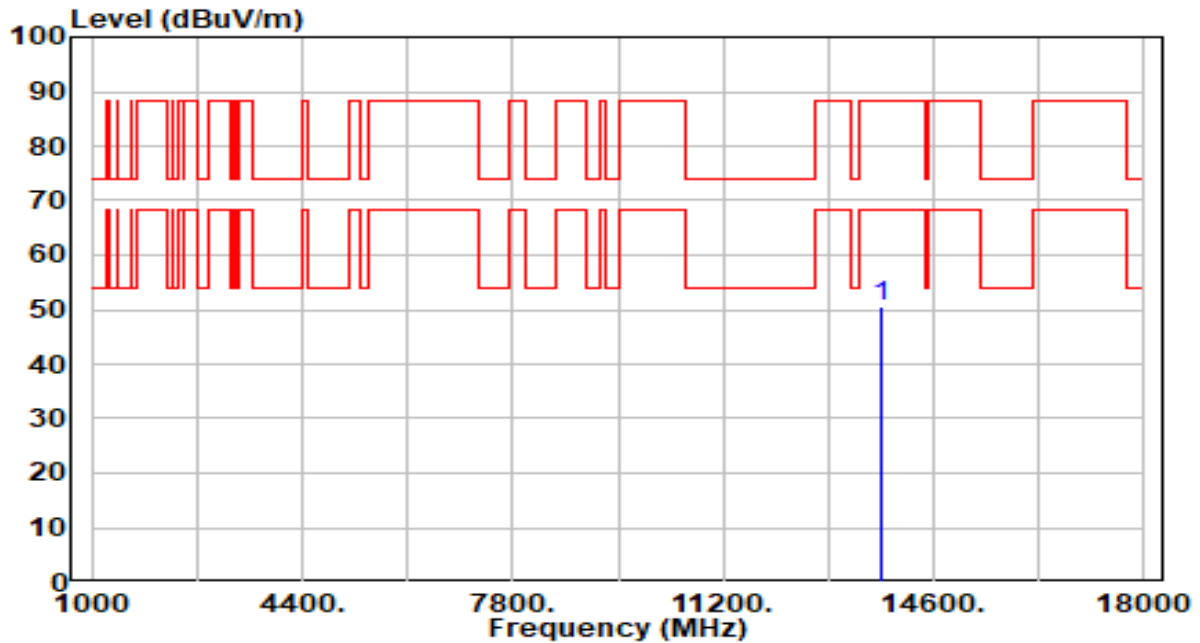

No	Frequency (MHz)	Reading (dBuV)	C.F (dB/m)	Measurement (dBuV/m)	Margin (dB)	Limit (dBuV/m)	Height (cm)	Angle (deg)	Remark (QP/PK/AV)
1	* 13750.000	43.93	6.53	50.45	-37.75	88.20	200	127	Peak

Note:

- "*", means this data is the worst emission level.
- C.F (Correction Factor) = Antenna Factor (dB/m)+ Cable Loss (dB) – Preamplifier(dB).
- Measurement (dBuV/m) = Reading(dBuV) + C.F (Correction Factor).
- The emission levels of other frequencies are very lower than the limit and not show in test report.

EUT	BE11000 Tri-Band Wi-Fi 7 Gaming Router	Date of Test	2024-01-16
Factor	DRH18-E	Temp. / Humidity	21°C /63%
Polarity	Horizontal	Site / Test Engineer	AC2 / Stanley
Test Mode	802.11be-20MHz_TX_Band8_CH 189_ANT 0+1 Nss2	Test Voltage	AC 120V/60Hz

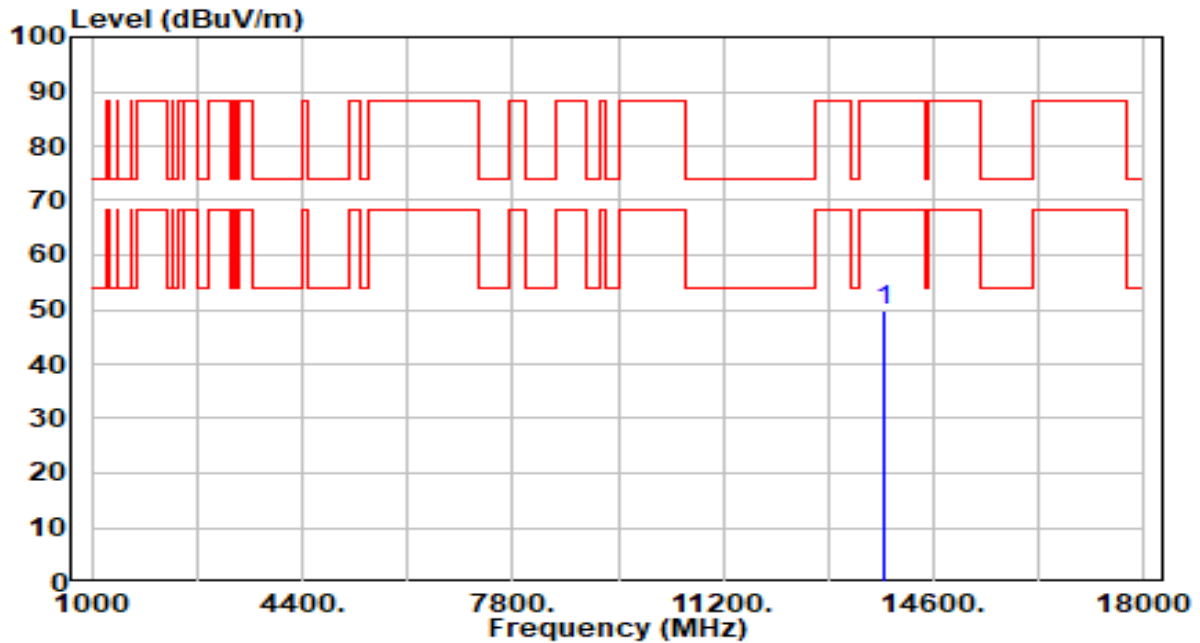

No	Frequency (MHz)	Reading (dBuV)	C.F (dB/m)	Measurement (dBuV/m)	Margin (dB)	Limit (dBuV/m)	Height (cm)	Angle (deg)	Remark (QP/PK/AV)
1	* 13790.000	43.46	6.52	49.99	-38.21	88.20	200	140	Peak

Note:

1. " *", means this data is the worst emission level.
2. C.F (Correction Factor) = Antenna Factor (dB/m)+ Cable Loss (dB) – Preamplifier(dB).
3. Measurement (dBuV/m) = Reading(dBuV) + C.F (Correction Factor).
4. The emission levels of other frequencies are very lower than the limit and not show in test report.

EUT	BE11000 Tri-Band Wi-Fi 7 Gaming Router	Date of Test	2024-01-16
Factor	DRH18-E	Temp. / Humidity	21°C /63%
Polarity	Vertical	Site / Test Engineer	AC2 / Stanley
Test Mode	802.11be-20MHz_TX_Band8_CH 189_ANT 0+1 Nss2	Test Voltage	AC 120V/60Hz

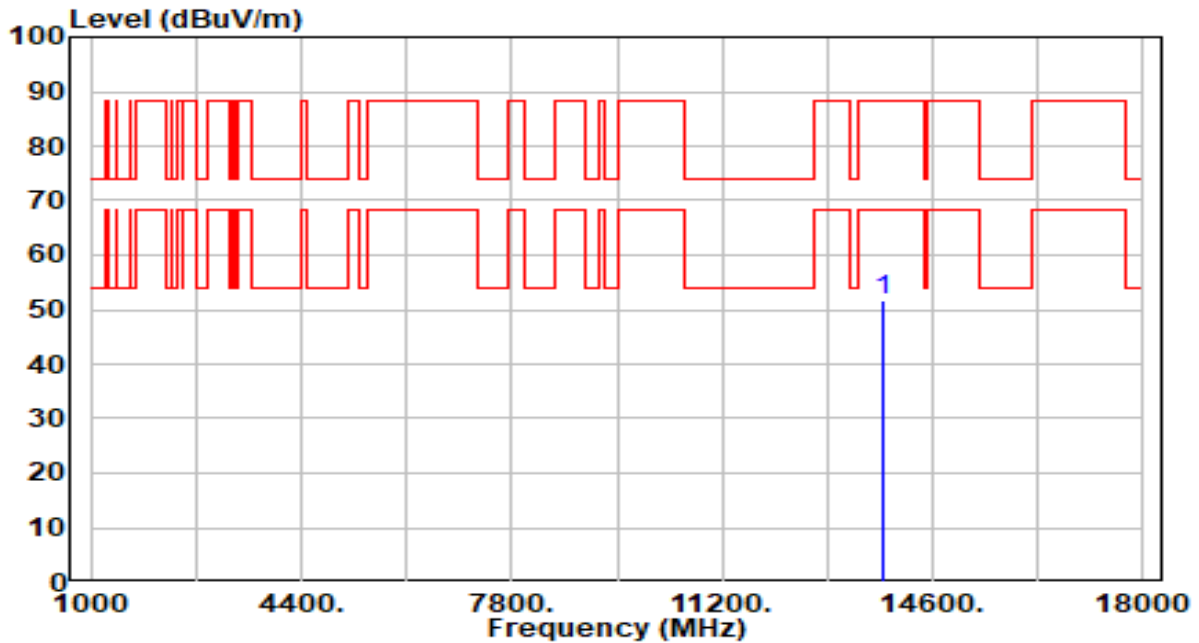

No	Frequency (MHz)	Reading (dBuV)	C.F (dB/m)	Measurement (dBuV/m)	Margin (dB)	Limit (dBuV/m)	Height (cm)	Angle (deg)	Remark (QP/PK/AV)
1	*	45.22	6.52	51.74	-36.46	88.20	200	125	Peak

Note:

- "*", means this data is the worst emission level.
- C.F (Correction Factor) = Antenna Factor (dB/m)+ Cable Loss (dB) – Preamplifier(dB).
- Measurement (dBuV/m) = Reading(dBuV) + C.F (Correction Factor).
- The emission levels of other frequencies are very lower than the limit and not show in test report.

EUT	BE11000 Tri-Band Wi-Fi 7 Gaming Router	Date of Test	2024-01-16
Factor	DRH18-E	Temp. / Humidity	21°C /63%
Polarity	Horizontal	Site / Test Engineer	AC2 / Marvin
Test Mode	802.11be-20MHz_TX_Band8_CH 213_ANT 0+1 Nss2	Test Voltage	AC 120V/60Hz

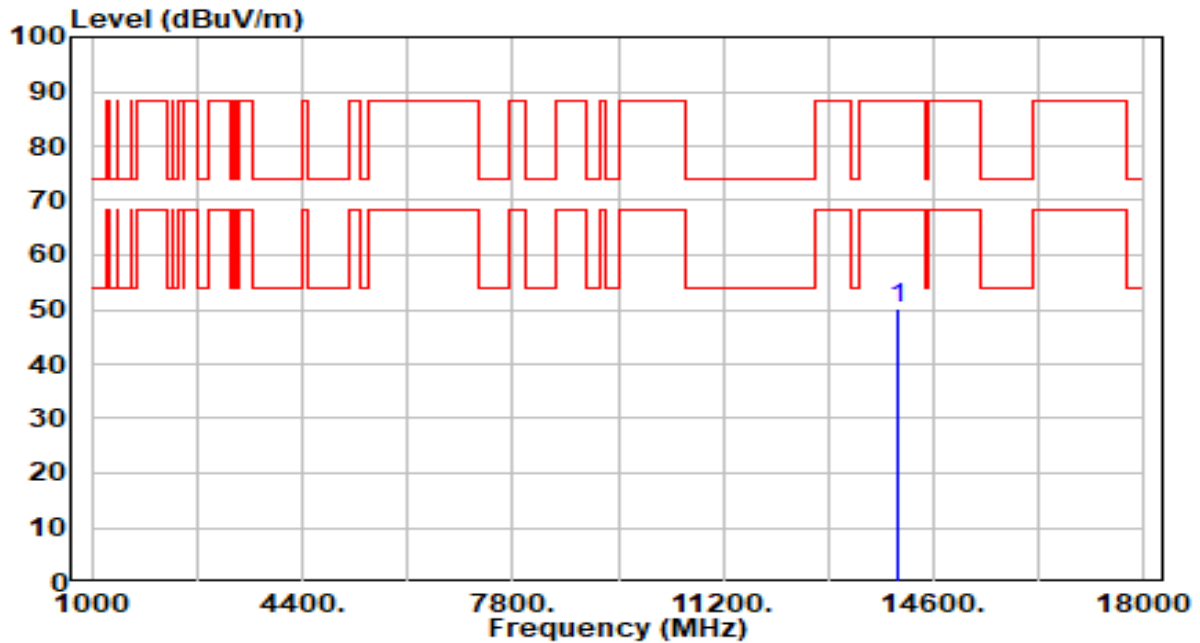

No	Frequency (MHz)	Reading (dBuV)	C.F (dB/m)	Measurement (dBuV/m)	Margin (dB)	Limit (dBuV/m)	Height (cm)	Angle (deg)	Remark (QP/PK/AV)
1	* 14030.000	43.43	6.63	50.06	-38.14	88.20	200	269	Peak

Note:

1. " *", means this data is the worst emission level.
2. C.F (Correction Factor) = Antenna Factor (dB/m)+ Cable Loss (dB) – Preamplifier(dB).
3. Measurement (dBuV/m) = Reading(dBuV) + C.F (Correction Factor).
4. The emission levels of other frequencies are very lower than the limit and not show in test report.

EUT	BE11000 Tri-Band Wi-Fi 7 Gaming Router	Date of Test	2024-01-16
Factor	DRH18-E	Temp. / Humidity	21°C /63%
Polarity	Vertical	Site / Test Engineer	AC2 / Marvin
Test Mode	802.11be-20MHz_TX_Band8_CH 213_ANT 0+1 Nss2	Test Voltage	AC 120V/60Hz

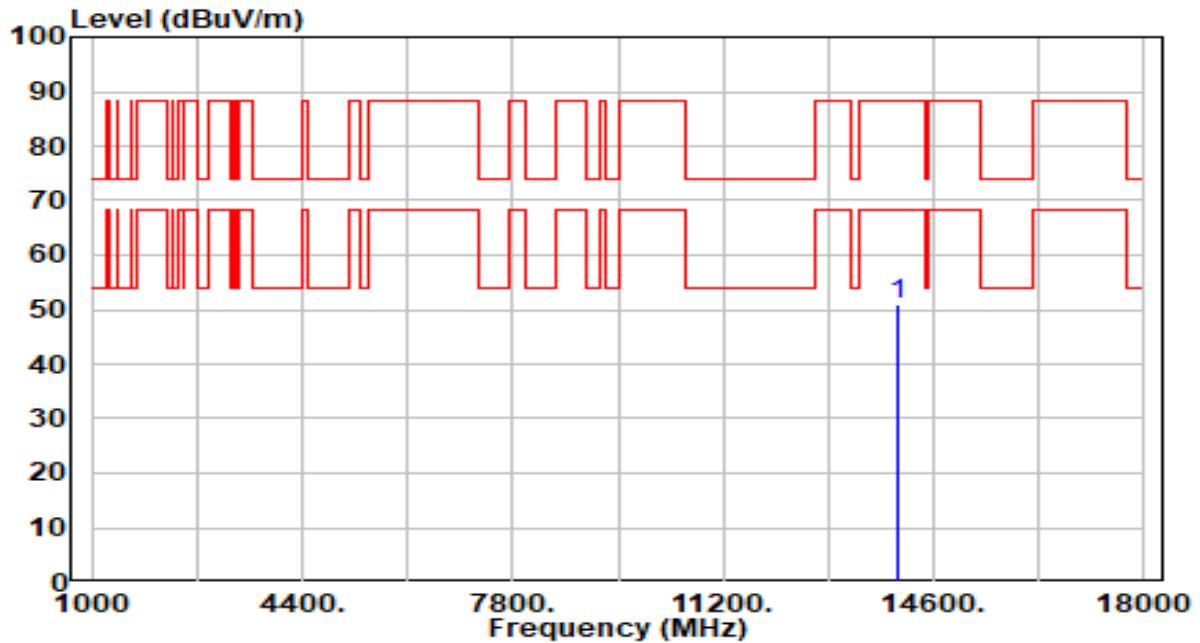

No	Frequency (MHz)	Reading (dBuV)	C.F (dB/m)	Measurement (dBuV/m)	Margin (dB)	Limit (dBuV/m)	Height (cm)	Angle (deg)	Remark (QP/PK/AV)
1	* 14030.000	44.15	6.63	50.77	-37.43	88.20	200	117	Peak

Note:

- "*", means this data is the worst emission level.
- C.F (Correction Factor) = Antenna Factor (dB/m)+ Cable Loss (dB) – Preamplifier(dB).
- Measurement (dBuV/m) = Reading(dBuV) + C.F (Correction Factor).
- The emission levels of other frequencies are very lower than the limit and not show in test report.

EUT	BE11000 Tri-Band Wi-Fi 7 Gaming Router	Date of Test	2024-01-16
Factor	DRH18-E	Temp. / Humidity	21°C /63%
Polarity	Horizontal	Site / Test Engineer	AC2 / Marvin
Test Mode	802.11be-20MHz_TX_Band8_CH 229_ANT 0+1 Nss2	Test Voltage	AC 120V/60Hz

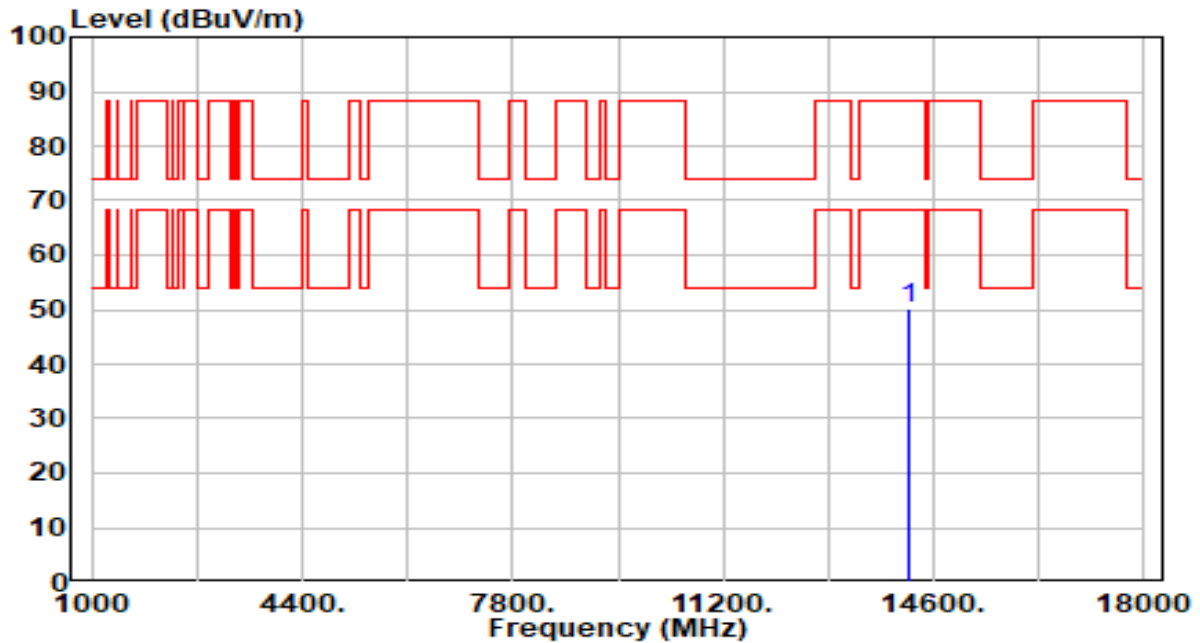

No	Frequency (MHz)	Reading (dBuV)	C.F (dB/m)	Measurement (dBuV/m)	Margin (dB)	Limit (dBuV/m)	Height (cm)	Angle (deg)	Remark (QP/PK/AV)
1	* 14190.000	43.37	6.66	50.02	-38.18	88.20	200	23	Peak

Note:

1. " *", means this data is the worst emission level.
2. C.F (Correction Factor) = Antenna Factor (dB/m)+ Cable Loss (dB) – Preamplifier(dB).
3. Measurement (dBuV/m) = Reading(dBuV) + C.F (Correction Factor).
4. The emission levels of other frequencies are very lower than the limit and not show in test report.

EUT	BE11000 Tri-Band Wi-Fi 7 Gaming Router	Date of Test	2024-01-16
Factor	DRH18-E	Temp. / Humidity	21°C /63%
Polarity	Vertical	Site / Test Engineer	AC2 / Marvin
Test Mode	802.11be-20MHz_TX_Band8_CH 229_ANT 0+1 Nss2	Test Voltage	AC 120V/60Hz

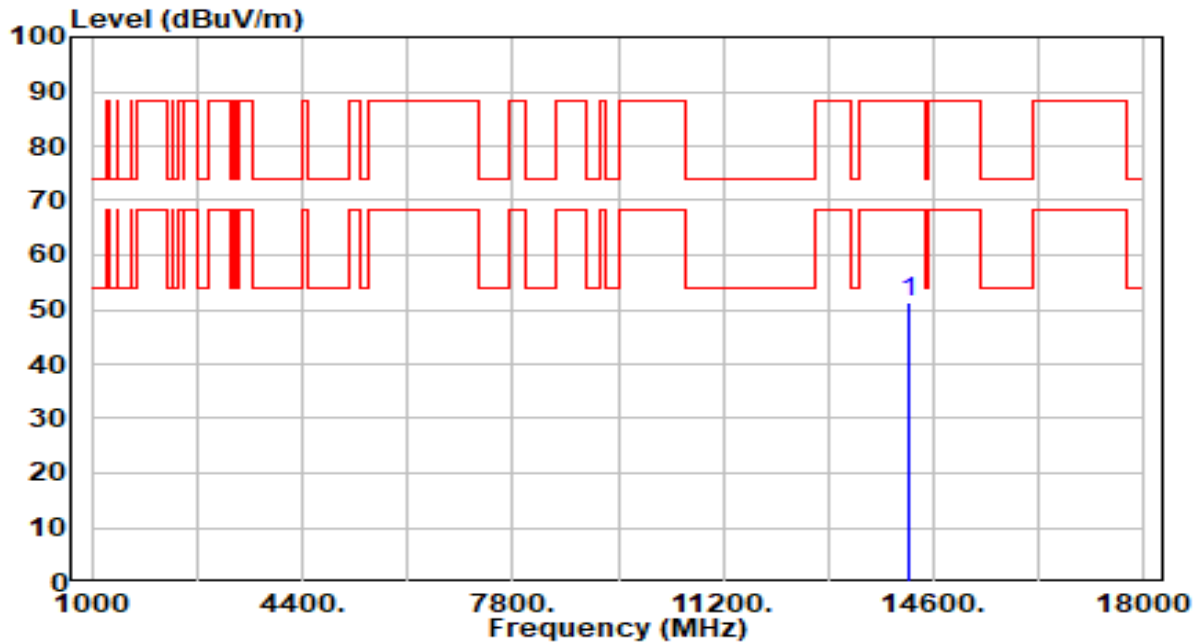

No	Frequency (MHz)	Reading (dBuV)	C.F (dB/m)	Measurement (dBuV/m)	Margin (dB)	Limit (dBuV/m)	Height (cm)	Angle (deg)	Remark (QP/PK/AV)
1	* 14190.000	44.78	6.66	51.44	-36.76	88.20	200	135	Peak

Note:

1. " *", means this data is the worst emission level.
2. C.F (Correction Factor) = Antenna Factor (dB/m)+ Cable Loss (dB) – Preamplifier(dB).
3. Measurement (dBuV/m) = Reading(dBuV) + C.F (Correction Factor).
4. The emission levels of other frequencies are very lower than the limit and not show in test report.

EUT	BE11000 Tri-Band Wi-Fi 7 Gaming Router	Date of Test	2024-01-16
Factor	DRH18-E	Temp. / Humidity	21°C /63%
Polarity	Horizontal	Site / Test Engineer	AC2 / Marvin
Test Mode	802.11be-40MHz_TX_Band5_CH 3_ANT 0+1 Nss2	Test Voltage	AC 120V/60Hz

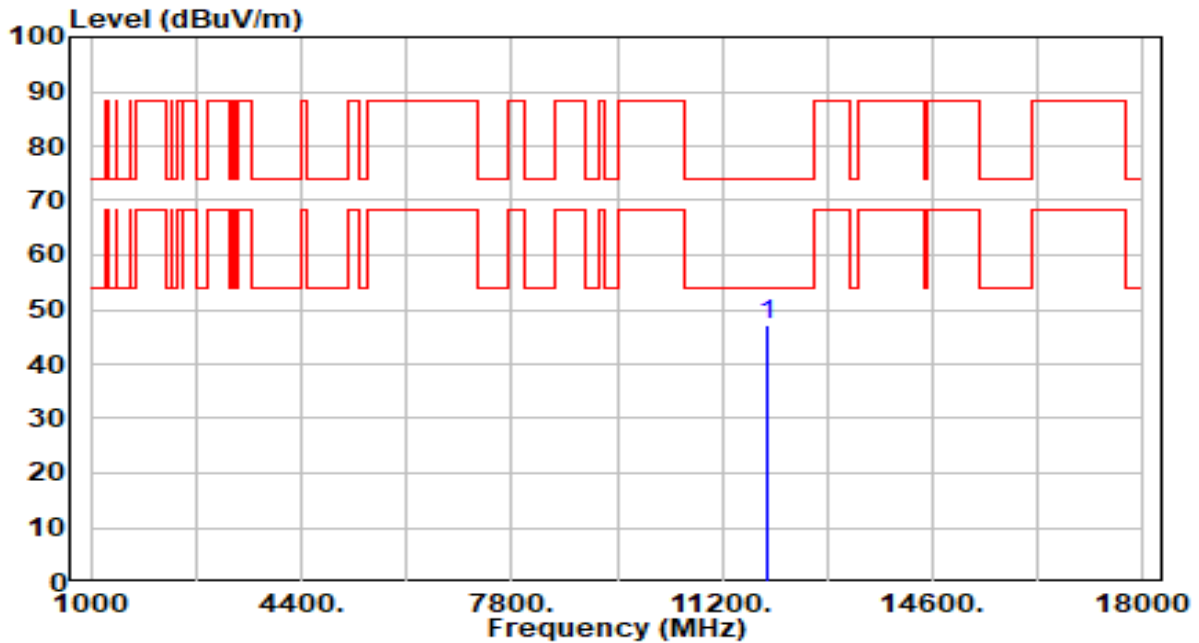

No	Frequency (MHz)	Reading (dBuV)	C.F (dB/m)	Measurement (dBuV/m)	Margin (dB)	Limit (dBuV/m)	Height (cm)	Angle (deg)	Remark (QP/PK/AV)
1	* 11930.000	41.89	5.41	47.30	-26.70	74.00	200	163	Peak

Note:

1. " *", means this data is the worst emission level.
2. C.F (Correction Factor) = Antenna Factor (dB/m)+ Cable Loss (dB) – Preamplifier(dB).
3. Measurement (dBuV/m) = Reading(dBuV) + C.F (Correction Factor).
4. The emission levels of other frequencies are very lower than the limit and not show in test report.

EUT	BE11000 Tri-Band Wi-Fi 7 Gaming Router	Date of Test	2024-01-16
Factor	DRH18-E	Temp. / Humidity	21°C /63%
Polarity	Vertical	Site / Test Engineer	AC2 / Marvin
Test Mode	802.11be-40MHz_TX_Band5_CH 3_ANT 0+1 Nss2	Test Voltage	AC 120V/60Hz

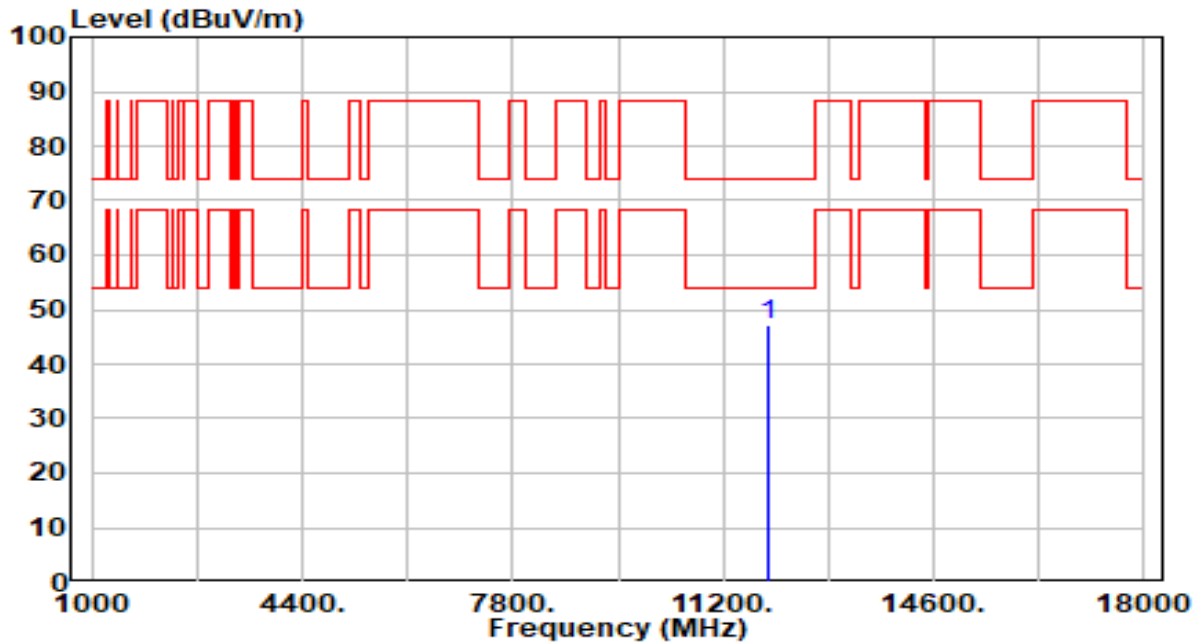

No	Frequency (MHz)	Reading (dBuV)	C.F (dB/m)	Measurement (dBuV/m)	Margin (dB)	Limit (dBuV/m)	Height (cm)	Angle (deg)	Remark (QP/PK/AV)
1	*	41.93	5.41	47.34	-26.66	74.00	200	77	Peak

Note:

- "*", means this data is the worst emission level.
- C.F (Correction Factor) = Antenna Factor (dB/m)+ Cable Loss (dB) – Preamplifier(dB).
- Measurement (dBuV/m) = Reading(dBuV) + C.F (Correction Factor).
- The emission levels of other frequencies are very lower than the limit and not show in test report.

EUT	BE11000 Tri-Band Wi-Fi 7 Gaming Router	Date of Test	2024-01-16
Factor	DRH18-E	Temp. / Humidity	21°C /63%
Polarity	Horizontal	Site / Test Engineer	AC2 / Marvin
Test Mode	802.11be-40MHz_TX_Band5_CH 43_ANT 0+1 Nss2	Test Voltage	AC 120V/60Hz

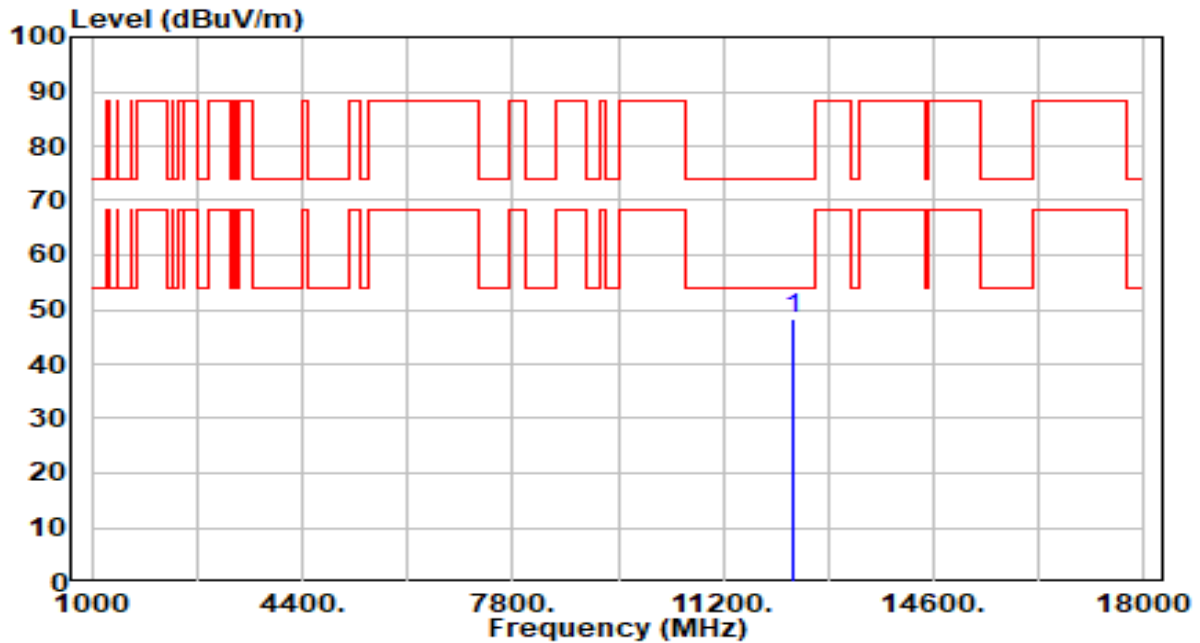

No	Frequency (MHz)	Reading (dBuV)	C.F (dB/m)	Measurement (dBuV/m)	Margin (dB)	Limit (dBuV/m)	Height (cm)	Angle (deg)	Remark (QP/PK/AV)
1	*	42.09	6.07	48.15	-25.85	74.00	200	134	Peak

Note:

1. " *", means this data is the worst emission level.
2. C.F (Correction Factor) = Antenna Factor (dB/m)+ Cable Loss (dB) – Preamplifier(dB).
3. Measurement (dBuV/m) = Reading(dBuV) + C.F (Correction Factor).
4. The emission levels of other frequencies are very lower than the limit and not show in test report.

EUT	BE11000 Tri-Band Wi-Fi 7 Gaming Router	Date of Test	2024-01-16
Factor	DRH18-E	Temp. / Humidity	21°C /63%
Polarity	Vertical	Site / Test Engineer	AC2 / Marvin
Test Mode	802.11be-40MHz_TX_Band5_CH 43_ANT 0+1 Nss2	Test Voltage	AC 120V/60Hz

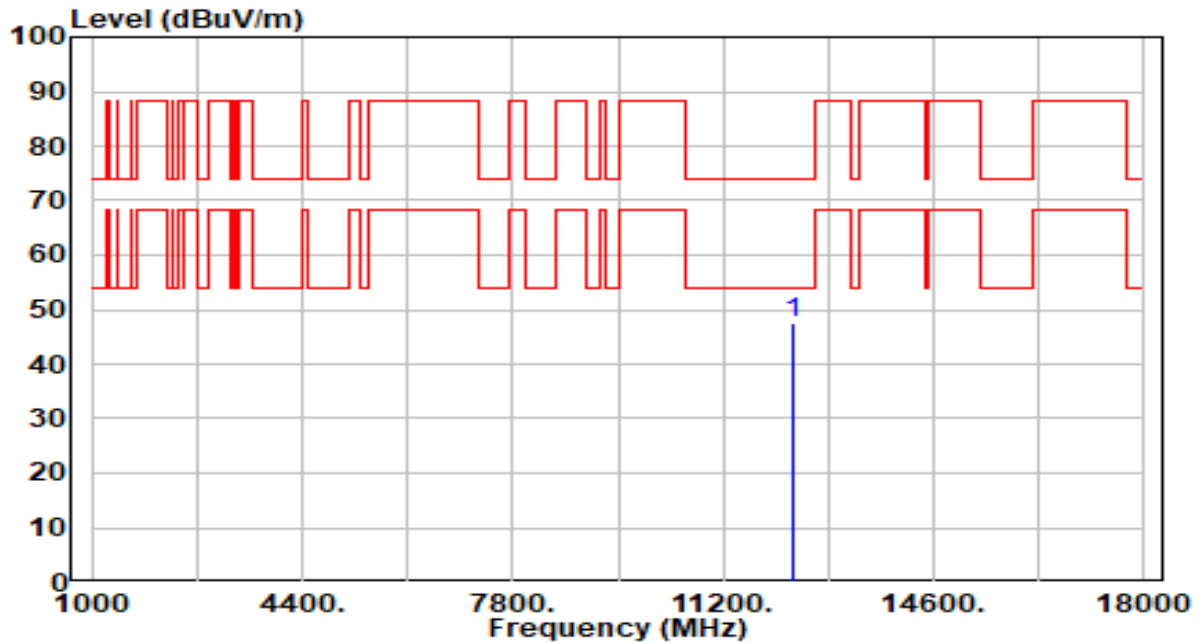

No	Frequency (MHz)	Reading (dBuV)	C.F (dB/m)	Measurement (dBuV/m)	Margin (dB)	Limit (dBuV/m)	Height (cm)	Angle (deg)	Remark (QP/PK/AV)
1	*	41.54	6.07	47.61	-26.39	74.00	200	197	Peak

Note:

1. " *", means this data is the worst emission level.
2. C.F (Correction Factor) = Antenna Factor (dB/m)+ Cable Loss (dB) – Preamplifier(dB).
3. Measurement (dBuV/m) = Reading(dBuV) + C.F (Correction Factor).
4. The emission levels of other frequencies are very lower than the limit and not show in test report.

EUT	BE11000 Tri-Band Wi-Fi 7 Gaming Router	Date of Test	2024-01-16
Factor	DRH18-E	Temp. / Humidity	21°C /63%
Polarity	Horizontal	Site / Test Engineer	AC2 / Marvin
Test Mode	802.11be-40MHz_TX_Band5_CH 91_ANT 0+1 Nss2	Test Voltage	AC 120V/60Hz

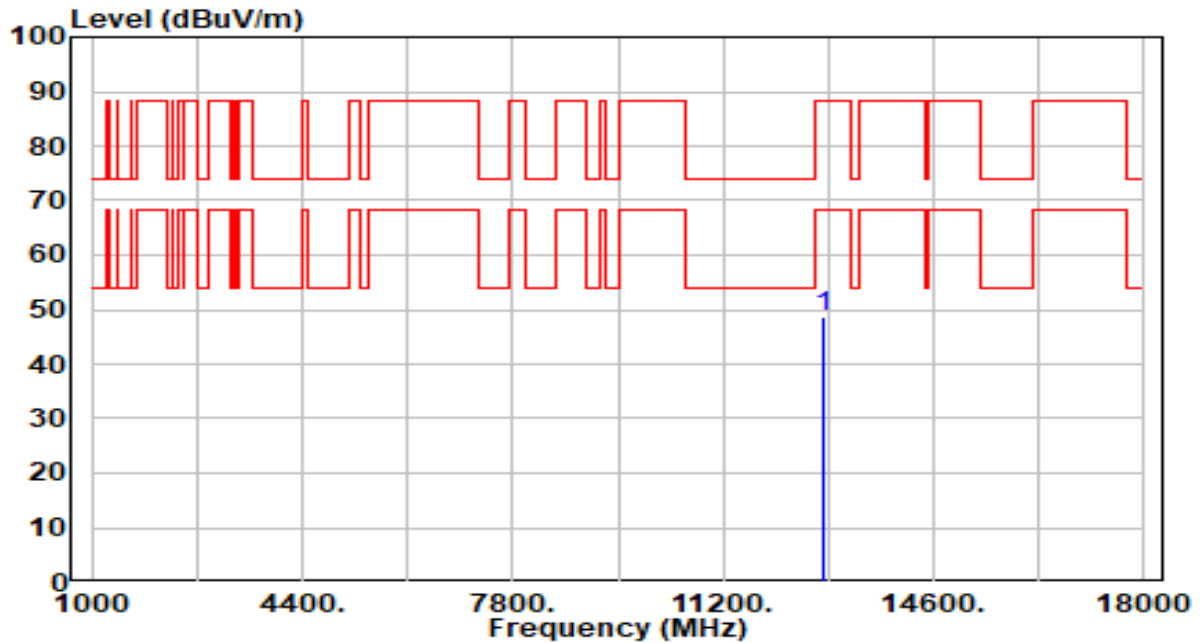

No	Frequency (MHz)	Reading (dBuV)	C.F (dB/m)	Measurement (dBuV/m)	Margin (dB)	Limit (dBuV/m)	Height (cm)	Angle (deg)	Remark (QP/PK/AV)
1	*	41.91	6.92	48.83	-39.37	88.20	200	28	Peak

Note:

- "*", means this data is the worst emission level.
- C.F (Correction Factor) = Antenna Factor (dB/m)+ Cable Loss (dB) – Preamplifier(dB).
- Measurement (dBuV/m) = Reading(dBuV) + C.F (Correction Factor).
- The emission levels of other frequencies are very lower than the limit and not show in test report.

EUT	BE11000 Tri-Band Wi-Fi 7 Gaming Router	Date of Test	2024-01-16
Factor	DRH18-E	Temp. / Humidity	21°C /63%
Polarity	Vertical	Site / Test Engineer	AC2 / Marvin
Test Mode	802.11be-40MHz_TX_Band5_CH 91_ANT 0+1 Nss2	Test Voltage	AC 120V/60Hz

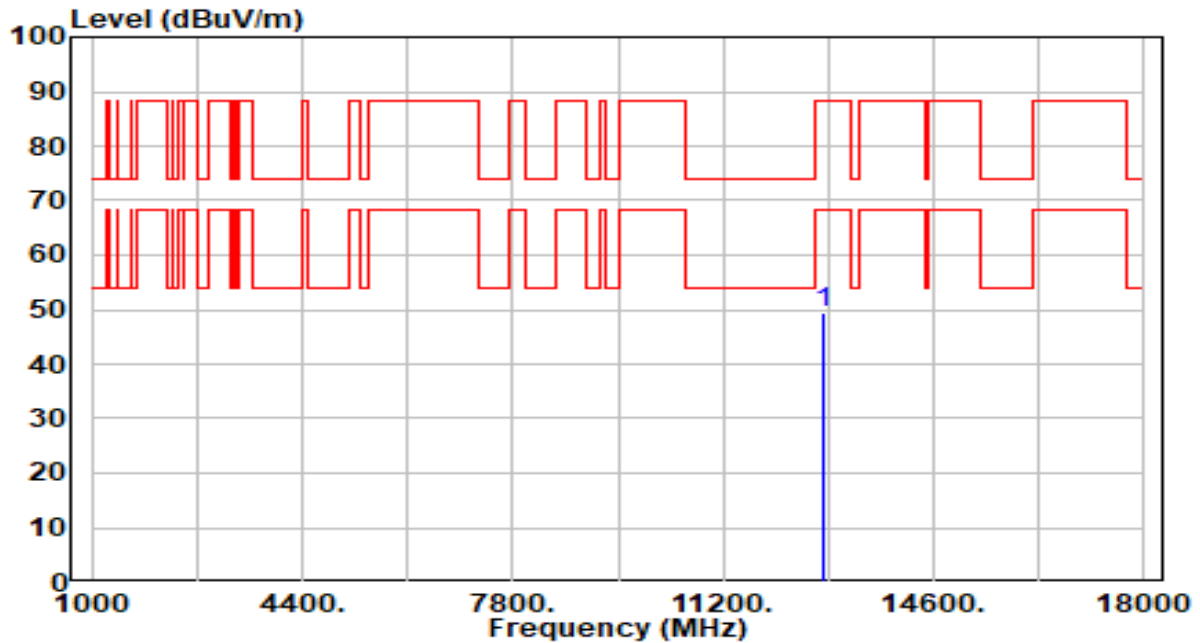

No	Frequency (MHz)	Reading (dBuV)	C.F (dB/m)	Measurement (dBuV/m)	Margin (dB)	Limit (dBuV/m)	Height (cm)	Angle (deg)	Remark (QP/PK/AV)
1	*	42.38	6.92	49.30	-38.90	88.20	200	125	Peak

Note:

- "*", means this data is the worst emission level.
- C.F (Correction Factor) = Antenna Factor (dB/m)+ Cable Loss (dB) – Preamplifier(dB).
- Measurement (dBuV/m) = Reading(dBuV) + C.F (Correction Factor).
- The emission levels of other frequencies are very lower than the limit and not show in test report.

EUT	BE11000 Tri-Band Wi-Fi 7 Gaming Router	Date of Test	2024-01-16
Factor	DRH18-E	Temp. / Humidity	21°C /63%
Polarity	Horizontal	Site / Test Engineer	AC2 / Marvin
Test Mode	802.11be-40MHz_TX_Band6_CH 99_ANT 0+1 Nss2	Test Voltage	AC 120V/60Hz

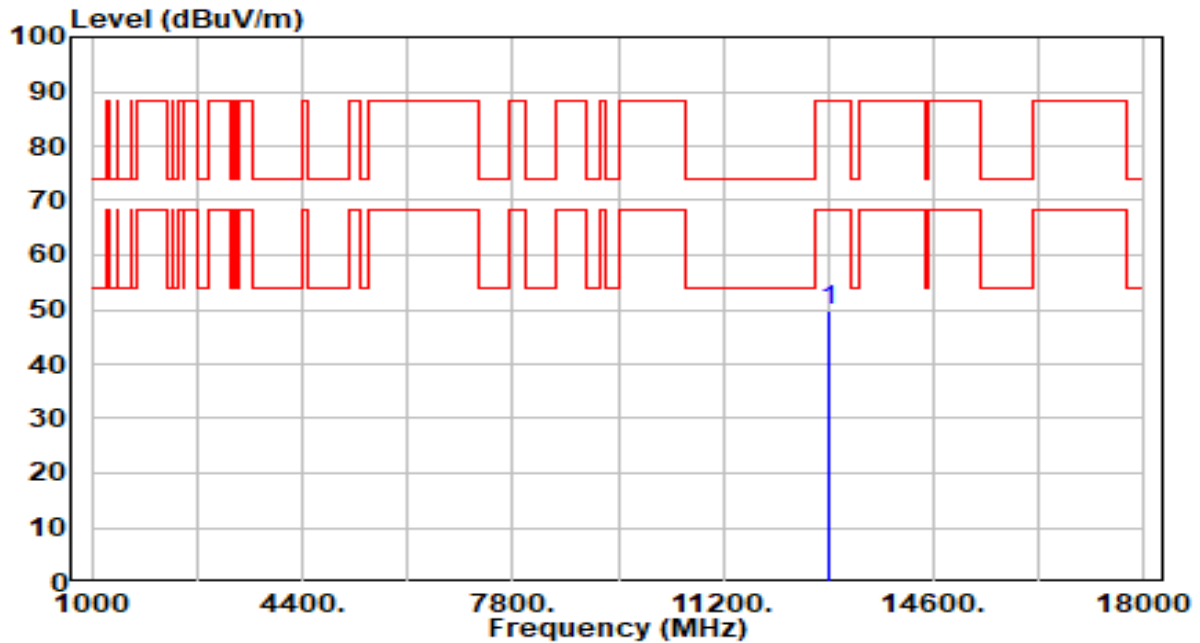

No	Frequency (MHz)	Reading (dBuV)	C.F (dB/m)	Measurement (dBuV/m)	Margin (dB)	Limit (dBuV/m)	Height (cm)	Angle (deg)	Remark (QP/PK/AV)
1	*	42.99	6.90	49.89	-38.31	88.20	200	296	Peak

Note:

- "*", means this data is the worst emission level.
- C.F (Correction Factor) = Antenna Factor (dB/m)+ Cable Loss (dB) – Preamplifier(dB).
- Measurement (dBuV/m) = Reading(dBuV) + C.F (Correction Factor).
- The emission levels of other frequencies are very lower than the limit and not show in test report.

EUT	BE11000 Tri-Band Wi-Fi 7 Gaming Router	Date of Test	2024-01-16
Factor	DRH18-E	Temp. / Humidity	21°C /63%
Polarity	Vertical	Site / Test Engineer	AC2 / Marvin
Test Mode	802.11be-40MHz_TX_Band6_CH 99_ANT 0+1 Nss2	Test Voltage	AC 120V/60Hz

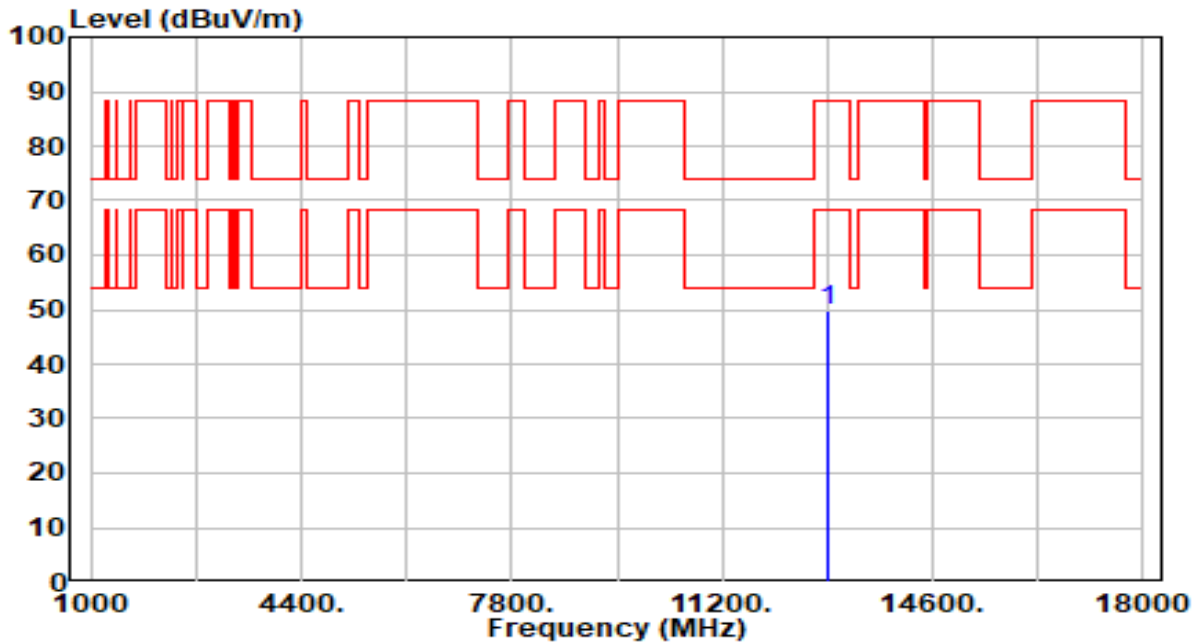

No	Frequency (MHz)	Reading (dBuV)	C.F (dB/m)	Measurement (dBuV/m)	Margin (dB)	Limit (dBuV/m)	Height (cm)	Angle (deg)	Remark (QP/PK/AV)
1	* 12890.000	42.87	6.90	49.77	-38.43	88.20	200	163	Peak

Note:

1. " *", means this data is the worst emission level.
2. C.F (Correction Factor) = Antenna Factor (dB/m)+ Cable Loss (dB) – Preamplifier(dB).
3. Measurement (dBuV/m) = Reading(dBuV) + C.F (Correction Factor).
4. The emission levels of other frequencies are very lower than the limit and not show in test report.

EUT	BE11000 Tri-Band Wi-Fi 7 Gaming Router	Date of Test	2024-01-16
Factor	DRH18-E	Temp. / Humidity	21°C /63%
Polarity	Horizontal	Site / Test Engineer	AC2 / Marvin
Test Mode	802.11be-40MHz_TX_Band6_CH 107_ANT 0+1 Nss2	Test Voltage	AC 120V/60Hz

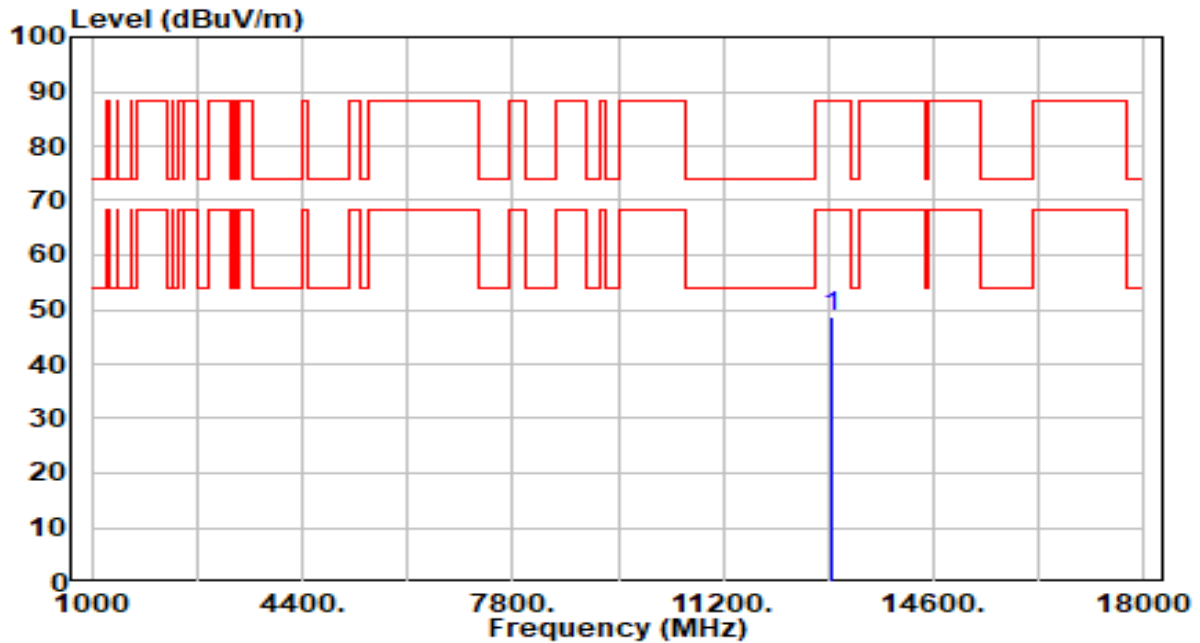

No	Frequency (MHz)	Reading (dBuV)	C.F (dB/m)	Measurement (dBuV/m)	Margin (dB)	Limit (dBuV/m)	Height (cm)	Angle (deg)	Remark (QP/PK/AV)
1	*	41.97	6.88	48.85	-39.35	88.20	0	0	Peak

Note:

1. " *", means this data is the worst emission level.
2. C.F (Correction Factor) = Antenna Factor (dB/m)+ Cable Loss (dB) – Preamplifier(dB).
3. Measurement (dBuV/m) = Reading(dBuV) + C.F (Correction Factor).
4. The emission levels of other frequencies are very lower than the limit and not show in test report.

EUT	BE11000 Tri-Band Wi-Fi 7 Gaming Router	Date of Test	2024-01-16
Factor	DRH18-E	Temp. / Humidity	21°C /63%
Polarity	Vertical	Site / Test Engineer	AC2 / Marvin
Test Mode	802.11be-40MHz_TX_Band6_CH 107_ANT 0+1 Nss2	Test Voltage	AC 120V/60Hz

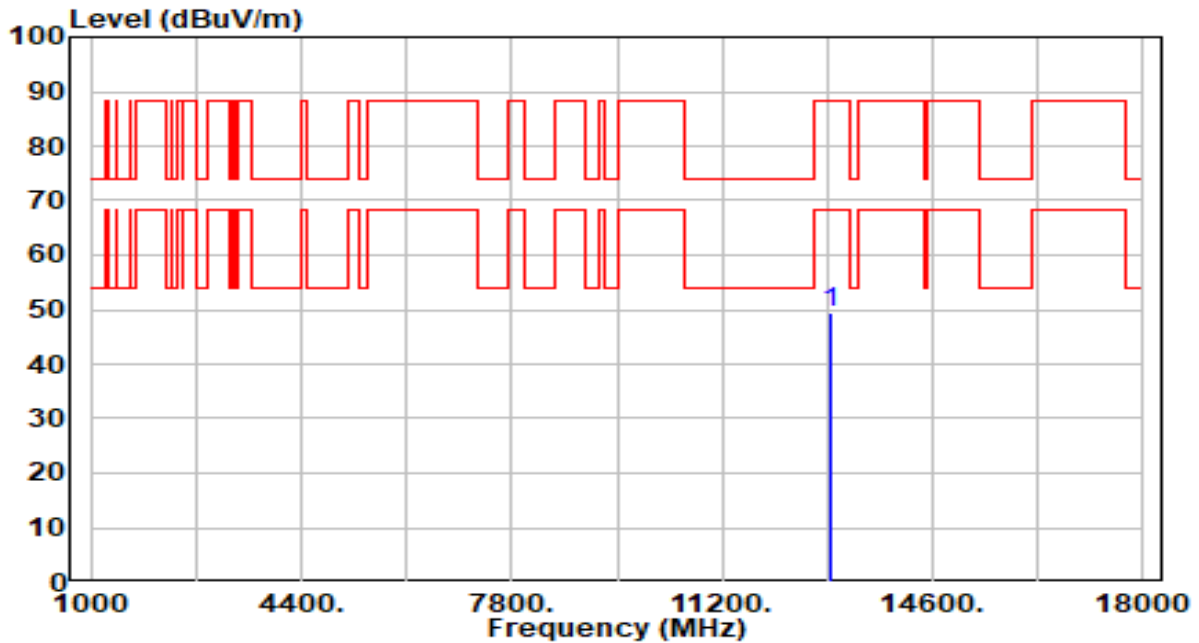

No	Frequency (MHz)	Reading (dBuV)	C.F (dB/m)	Measurement (dBuV/m)	Margin (dB)	Limit (dBuV/m)	Height (cm)	Angle (deg)	Remark (QP/PK/AV)
1	*	42.56	6.88	49.44	-38.76	88.20	200	124	Peak

Note:

1. " *", means this data is the worst emission level.
2. C.F (Correction Factor) = Antenna Factor (dB/m)+ Cable Loss (dB) – Preamplifier(dB).
3. Measurement (dBuV/m) = Reading(dBuV) + C.F (Correction Factor).
4. The emission levels of other frequencies are very lower than the limit and not show in test report.

EUT	BE11000 Tri-Band Wi-Fi 7 Gaming Router	Date of Test	2024-01-16
Factor	DRH18-E	Temp. / Humidity	21°C /63%
Polarity	Horizontal	Site / Test Engineer	AC2 / Marvin
Test Mode	802.11be-40MHz_TX_Band6_CH 115_ANT 0+1 Nss2	Test Voltage	AC 120V/60Hz

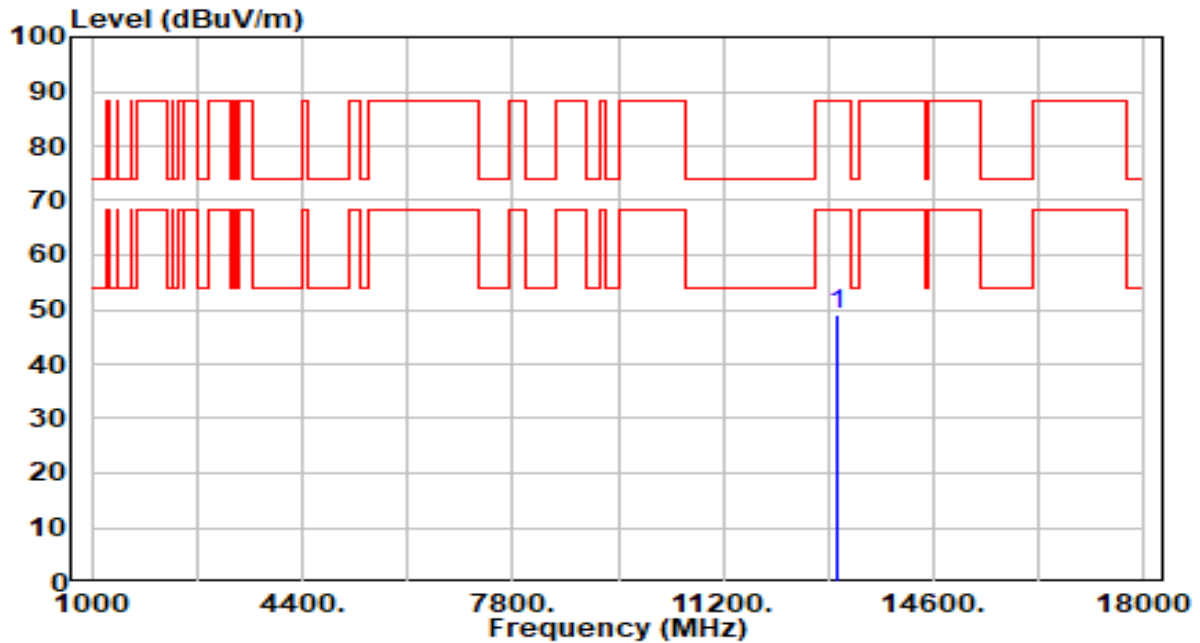

No	Frequency (MHz)	Reading (dBuV)	C.F (dB/m)	Measurement (dBuV/m)	Margin (dB)	Limit (dBuV/m)	Height (cm)	Angle (deg)	Remark (QP/PK/AV)
1	*	42.25	6.85	49.11	-39.09	88.20	200	25	Peak

Note:

- "*", means this data is the worst emission level.
- C.F (Correction Factor) = Antenna Factor (dB/m)+ Cable Loss (dB) – Preamplifier(dB).
- Measurement (dBuV/m) = Reading(dBuV) + C.F (Correction Factor).
- The emission levels of other frequencies are very lower than the limit and not show in test report.

EUT	BE11000 Tri-Band Wi-Fi 7 Gaming Router	Date of Test	2024-01-16
Factor	DRH18-E	Temp. / Humidity	21°C /63%
Polarity	Vertical	Site / Test Engineer	AC2 / Marvin
Test Mode	802.11be-40MHz_TX_Band6_CH 115_ANT 0+1 Nss2	Test Voltage	AC 120V/60Hz

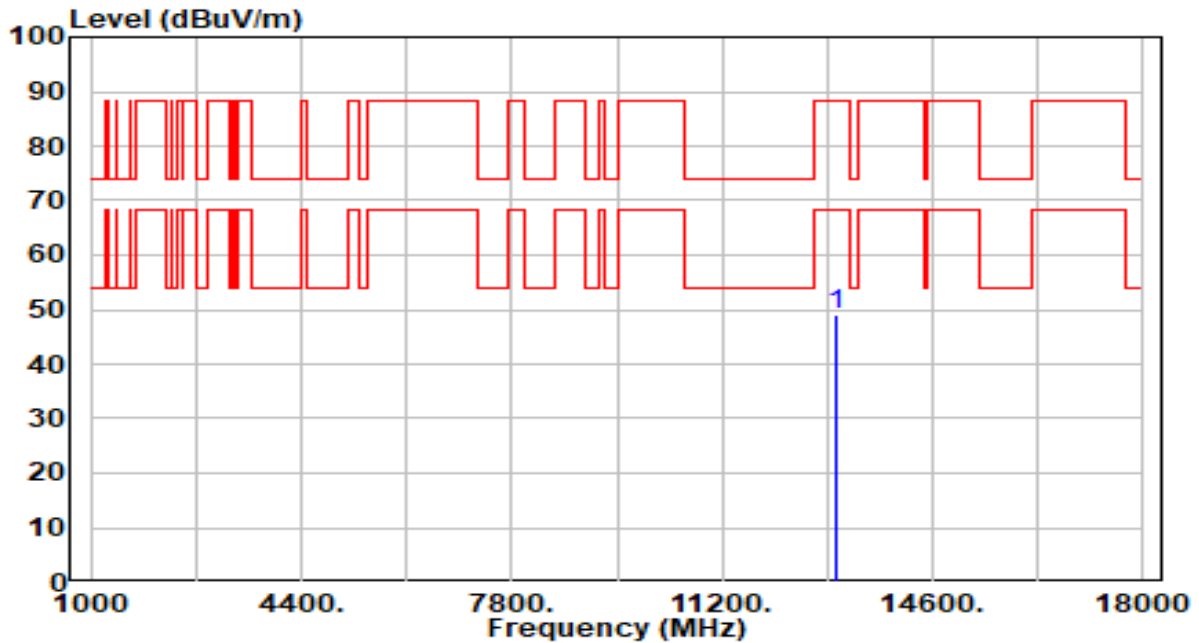

No	Frequency (MHz)	Reading (dBuV)	C.F (dB/m)	Measurement (dBuV/m)	Margin (dB)	Limit (dBuV/m)	Height (cm)	Angle (deg)	Remark (QP/PK/AV)
1	*	42.37	6.85	49.22	-38.98	88.20	200	166	Peak

Note:

1. " *", means this data is the worst emission level.
2. C.F (Correction Factor) = Antenna Factor (dB/m)+ Cable Loss (dB) – Preamplifier(dB).
3. Measurement (dBuV/m) = Reading(dBuV) + C.F (Correction Factor).
4. The emission levels of other frequencies are very lower than the limit and not show in test report.

EUT	BE11000 Tri-Band Wi-Fi 7 Gaming Router	Date of Test	2024-01-16
Factor	DRH18-E	Temp. / Humidity	21°C /63%
Polarity	Horizontal	Site / Test Engineer	AC2 / Marvin
Test Mode	802.11be-40MHz_TX_Band7_CH 123_ANT 0+1 Nss2	Test Voltage	AC 120V/60Hz

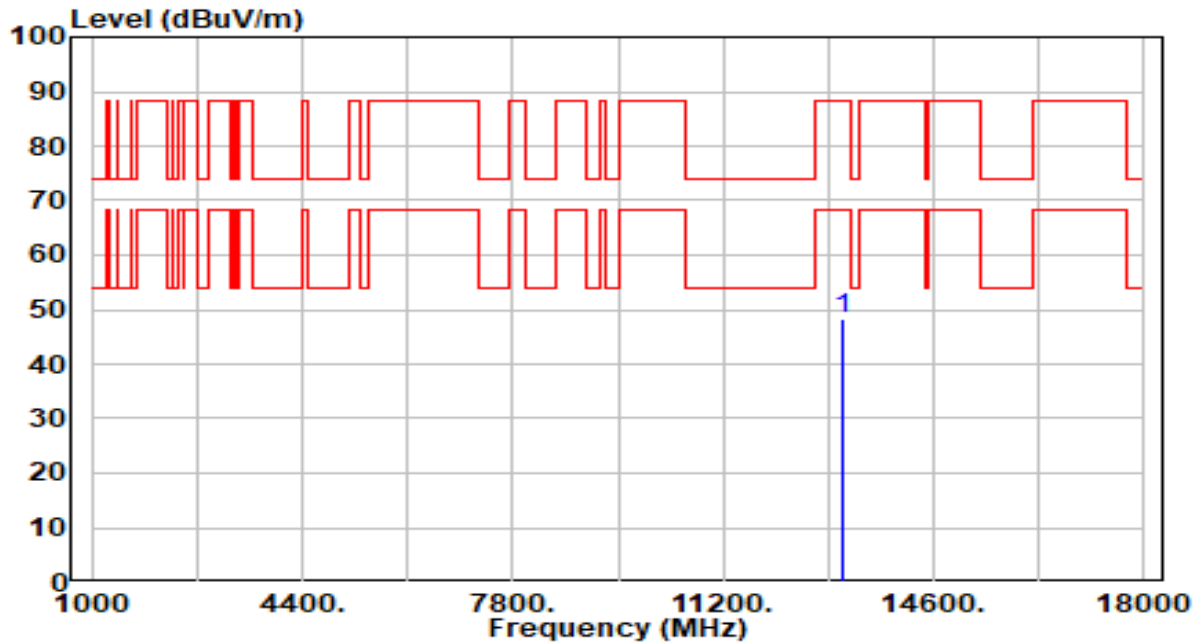

No	Frequency (MHz)	Reading (dBuV)	C.F (dB/m)	Measurement (dBuV/m)	Margin (dB)	Limit (dBuV/m)	Height (cm)	Angle (deg)	Remark (QP/PK/AV)
1	*	41.58	6.82	48.40	-39.80	88.20	200	311	Peak

Note:

1. " *", means this data is the worst emission level.
2. C.F (Correction Factor) = Antenna Factor (dB/m)+ Cable Loss (dB) – Preamplifier(dB).
3. Measurement (dBuV/m) = Reading(dBuV) + C.F (Correction Factor).
4. The emission levels of other frequencies are very lower than the limit and not show in test report.

EUT	BE11000 Tri-Band Wi-Fi 7 Gaming Router	Date of Test	2024-01-16
Factor	DRH18-E	Temp. / Humidity	21°C /63%
Polarity	Vertical	Site / Test Engineer	AC2 / Marvin
Test Mode	802.11be-40MHz_TX_Band7_CH 123_ANT 0+1 Nss2	Test Voltage	AC 120V/60Hz

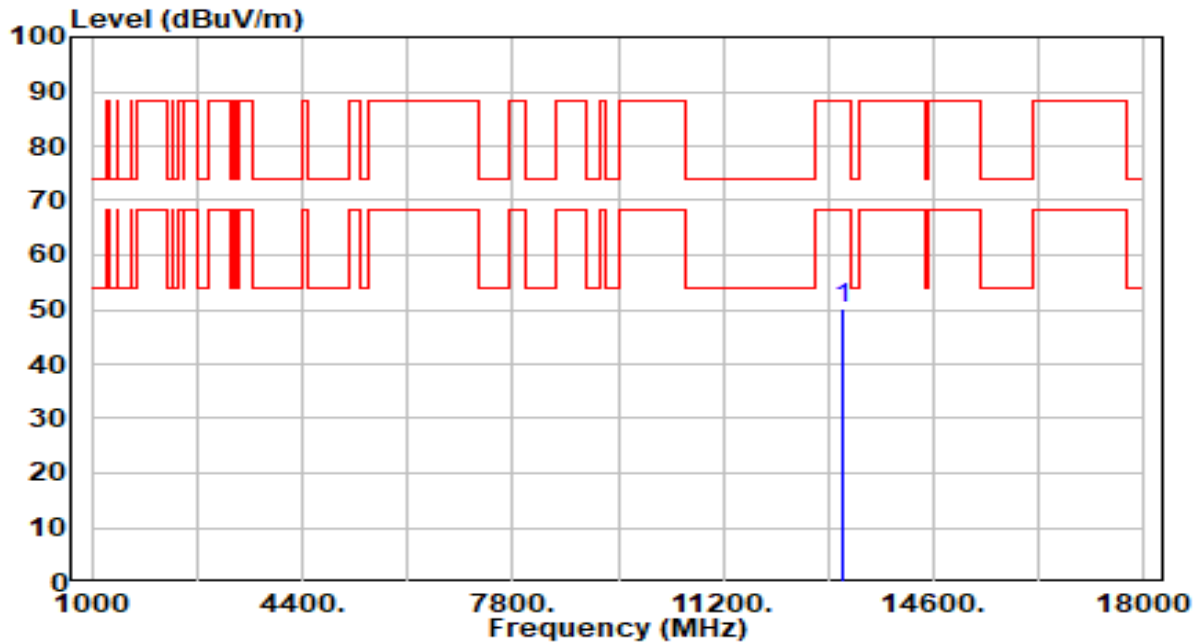

No	Frequency (MHz)	Reading (dBuV)	C.F (dB/m)	Measurement (dBuV/m)	Margin (dB)	Limit (dBuV/m)	Height (cm)	Angle (deg)	Remark (QP/PK/AV)
1	* 13130.000	43.26	6.82	50.08	-38.12	88.20	200	29	Peak

Note:

1. " *", means this data is the worst emission level.
2. C.F (Correction Factor) = Antenna Factor (dB/m)+ Cable Loss (dB) – Preamplifier(dB).
3. Measurement (dBuV/m) = Reading(dBuV) + C.F (Correction Factor).
4. The emission levels of other frequencies are very lower than the limit and not show in test report.

EUT	BE11000 Tri-Band Wi-Fi 7 Gaming Router	Date of Test	2024-01-16
Factor	DRH18-E	Temp. / Humidity	21°C /63%
Polarity	Horizontal	Site / Test Engineer	AC2 / Marvin
Test Mode	802.11be-40MHz_TX_Band7_CH 147_ANT 0+1 Nss2	Test Voltage	AC 120V/60Hz

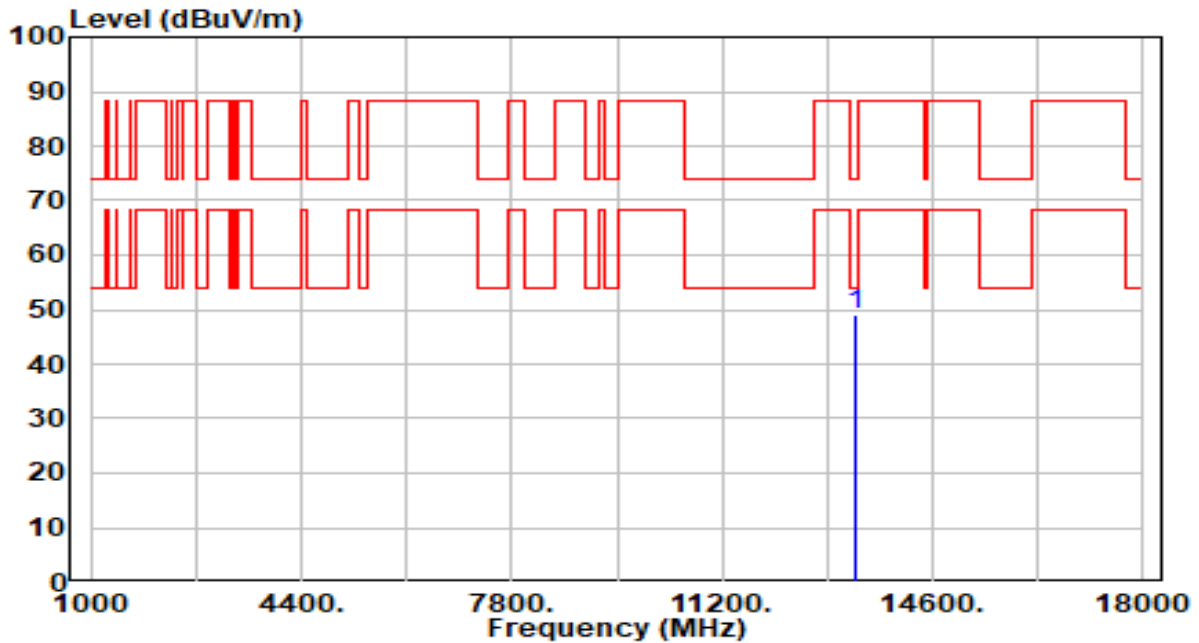

No	Frequency (MHz)	Reading (dBuV)	C.F (dB/m)	Measurement (dBuV/m)	Margin (dB)	Limit (dBuV/m)	Height (cm)	Angle (deg)	Remark (QP/PK/AV)
1	*	42.39	6.81	49.20	-24.80	74.00	200	14	Peak

Note:

- "*", means this data is the worst emission level.
- C.F (Correction Factor) = Antenna Factor (dB/m)+ Cable Loss (dB) – Preamplifier(dB).
- Measurement (dBuV/m) = Reading(dBuV) + C.F (Correction Factor).
- The emission levels of other frequencies are very lower than the limit and not show in test report.

EUT	BE11000 Tri-Band Wi-Fi 7 Gaming Router	Date of Test	2024-01-16
Factor	DRH18-E	Temp. / Humidity	21°C /63%
Polarity	Vertical	Site / Test Engineer	AC2 / Marvin
Test Mode	802.11be-40MHz_TX_Band7_CH 147_ANT 0+1 Nss2	Test Voltage	AC 120V/60Hz

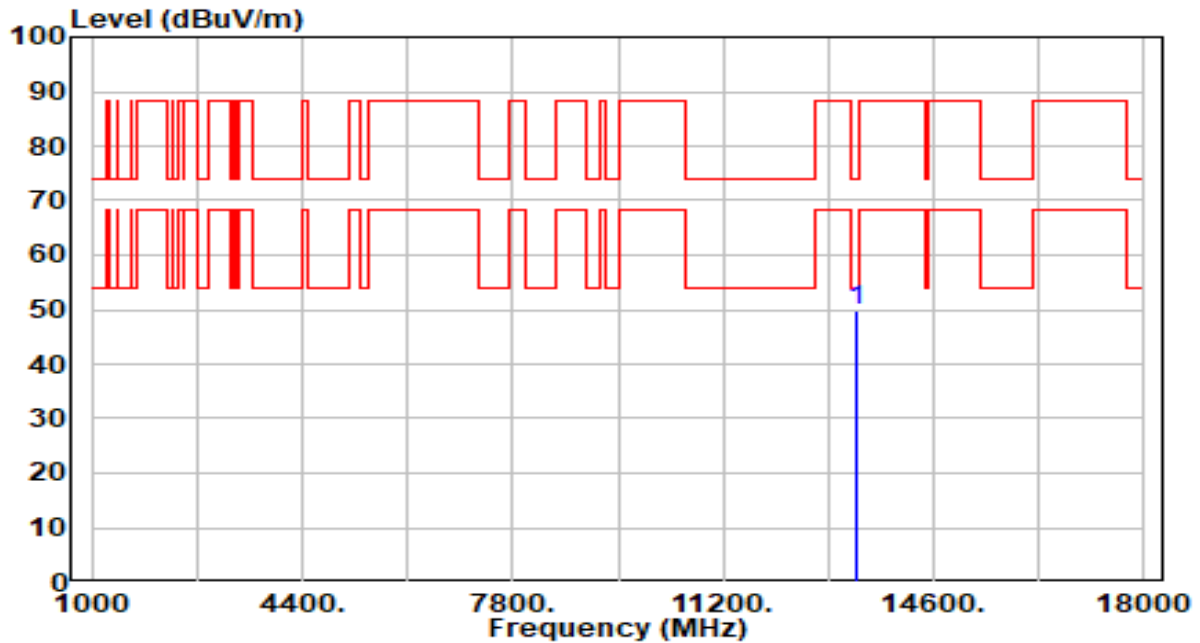

No	Frequency (MHz)	Reading (dBuV)	C.F (dB/m)	Measurement (dBuV/m)	Margin (dB)	Limit (dBuV/m)	Height (cm)	Angle (deg)	Remark (QP/PK/AV)
1	*	43.01	6.81	49.82	-24.18	74.00	200	194	Peak

Note:

- "*", means this data is the worst emission level.
- C.F (Correction Factor) = Antenna Factor (dB/m)+ Cable Loss (dB) – Preamplifier(dB).
- Measurement (dBuV/m) = Reading(dBuV) + C.F (Correction Factor).
- The emission levels of other frequencies are very lower than the limit and not show in test report.

EUT	BE11000 Tri-Band Wi-Fi 7 Gaming Router	Date of Test	2024-01-16
Factor	DRH18-E	Temp. / Humidity	21°C /63%
Polarity	Horizontal	Site / Test Engineer	AC2 / Marvin
Test Mode	802.11be-40MHz_TX_Band7_CH 179_ANT 0+1 Nss2	Test Voltage	AC 120V/60Hz

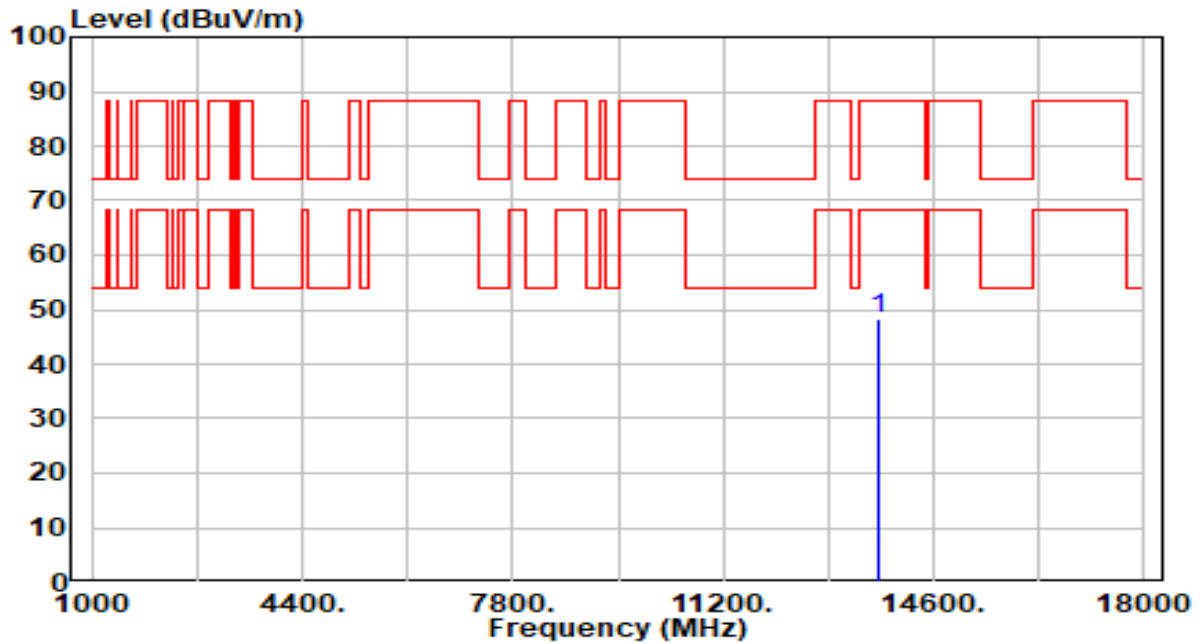

No	Frequency (MHz)	Reading (dBuV)	C.F (dB/m)	Measurement (dBuV/m)	Margin (dB)	Limit (dBuV/m)	Height (cm)	Angle (deg)	Remark (QP/PK/AV)
1	*	41.96	6.53	48.48	-39.72	88.20	200	120	Peak

Note:

1. " *", means this data is the worst emission level.
2. C.F (Correction Factor) = Antenna Factor (dB/m)+ Cable Loss (dB) – Preamplifier(dB).
3. Measurement (dBuV/m) = Reading(dBuV) + C.F (Correction Factor).
4. The emission levels of other frequencies are very lower than the limit and not show in test report.

EUT	BE11000 Tri-Band Wi-Fi 7 Gaming Router	Date of Test	2024-01-16
Factor	DRH18-E	Temp. / Humidity	21°C /63%
Polarity	Vertical	Site / Test Engineer	AC2 / Marvin
Test Mode	802.11be-40MHz_TX_Band7_CH 179_ANT 0+1 Nss2	Test Voltage	AC 120V/60Hz

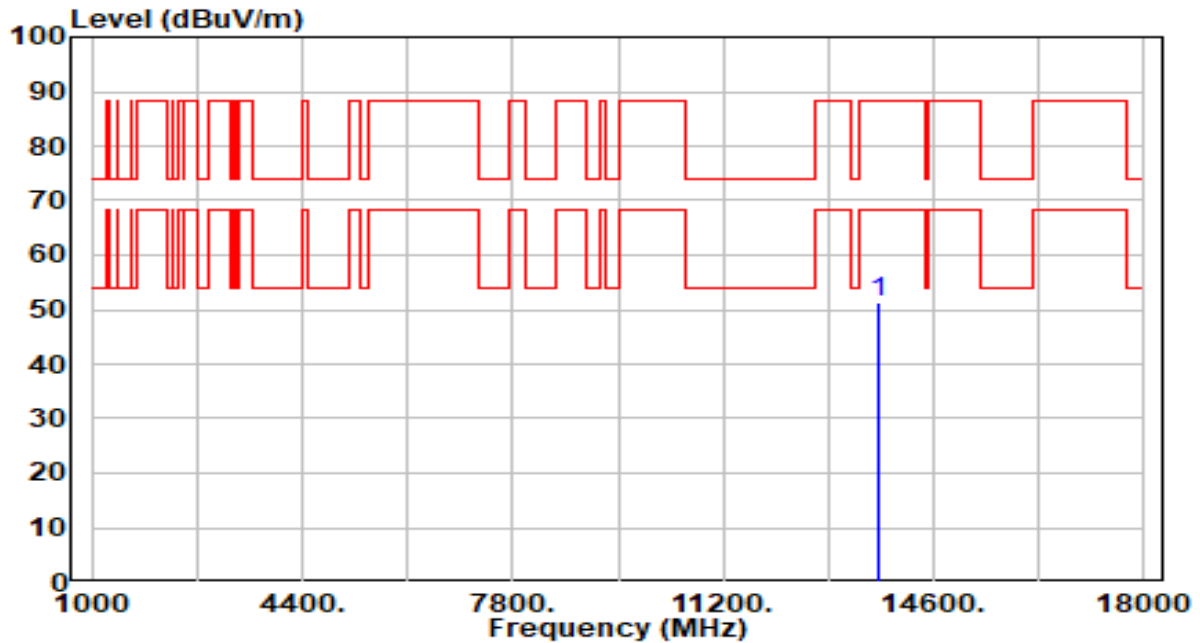

No	Frequency (MHz)	Reading (dBuV)	C.F (dB/m)	Measurement (dBuV/m)	Margin (dB)	Limit (dBuV/m)	Height (cm)	Angle (deg)	Remark (QP/PK/AV)
1	*	44.65	6.53	51.18	-37.02	88.20	200	55	Peak

Note:

- "*", means this data is the worst emission level.
- C.F (Correction Factor) = Antenna Factor (dB/m)+ Cable Loss (dB) – Preamplifier(dB).
- Measurement (dBuV/m) = Reading(dBuV) + C.F (Correction Factor).
- The emission levels of other frequencies are very lower than the limit and not show in test report.

EUT	BE11000 Tri-Band Wi-Fi 7 Gaming Router	Date of Test	2024-01-16
Factor	DRH18-E	Temp. / Humidity	21°C /63%
Polarity	Horizontal	Site / Test Engineer	AC2 / Marvin
Test Mode	802.11be-40MHz_TX_Band8_CH 187_ANT 0+1 Nss2	Test Voltage	AC 120V/60Hz

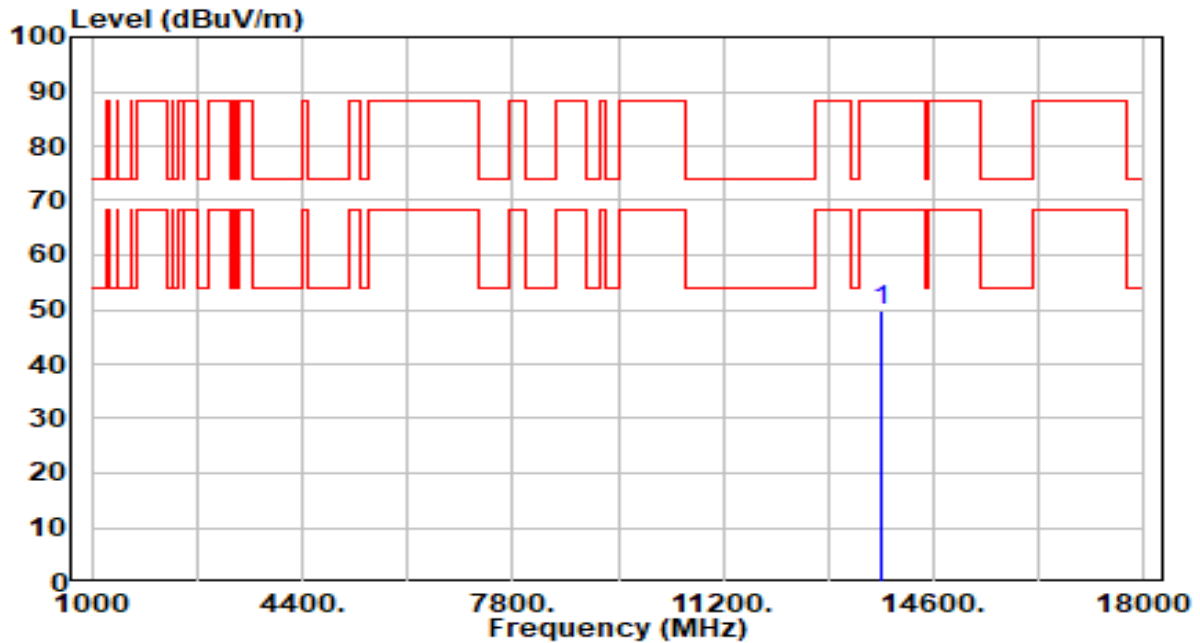

No	Frequency (MHz)	Reading (dBuV)	C.F (dB/m)	Measurement (dBuV/m)	Margin (dB)	Limit (dBuV/m)	Height (cm)	Angle (deg)	Remark (QP/PK/AV)
1	* 13770.000	43.29	6.52	49.81	-38.39	88.20	200	0	Peak

Note:

1. " *", means this data is the worst emission level.
2. C.F (Correction Factor) = Antenna Factor (dB/m)+ Cable Loss (dB) – Preamplifier(dB).
3. Measurement (dBuV/m) = Reading(dBuV) + C.F (Correction Factor).
4. The emission levels of other frequencies are very lower than the limit and not show in test report.

EUT	BE11000 Tri-Band Wi-Fi 7 Gaming Router	Date of Test	2024-01-16
Factor	DRH18-E	Temp. / Humidity	21°C /63%
Polarity	Vertical	Site / Test Engineer	AC2 / Marvin
Test Mode	802.11be-40MHz_TX_Band8_CH 187_ANT 0+1 Nss2	Test Voltage	AC 120V/60Hz

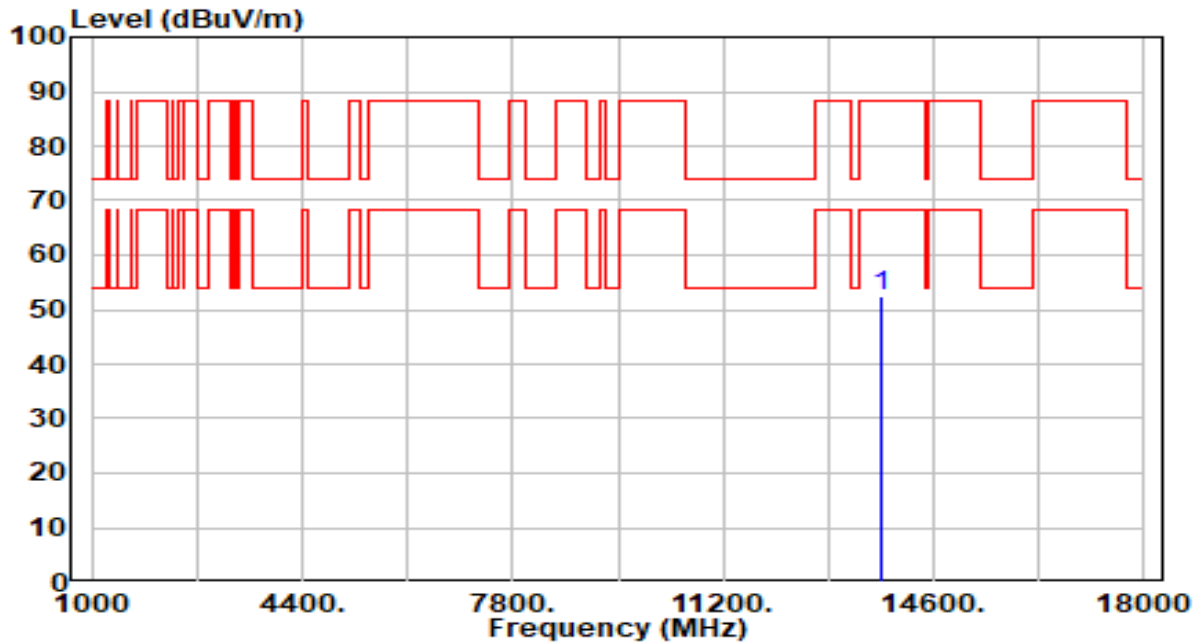

No	Frequency (MHz)	Reading (dBuV)	C.F (dB/m)	Measurement (dBuV/m)	Margin (dB)	Limit (dBuV/m)	Height (cm)	Angle (deg)	Remark (QP/PK/AV)
1	*	45.93	6.52	52.46	-35.74	88.20	200	130	Peak

Note:

- "*", means this data is the worst emission level.
- C.F (Correction Factor) = Antenna Factor (dB/m)+ Cable Loss (dB) – Preamplifier(dB).
- Measurement (dBuV/m) = Reading(dBuV) + C.F (Correction Factor).
- The emission levels of other frequencies are very lower than the limit and not show in test report.

EUT	BE11000 Tri-Band Wi-Fi 7 Gaming Router	Date of Test	2024-01-16
Factor	DRH18-E	Temp. / Humidity	21°C /63%
Polarity	Horizontal	Site / Test Engineer	AC2 / Marvin
Test Mode	802.11be-40MHz_TX_Band8_CH 195_ANT 0+1 Nss2	Test Voltage	AC 120V/60Hz

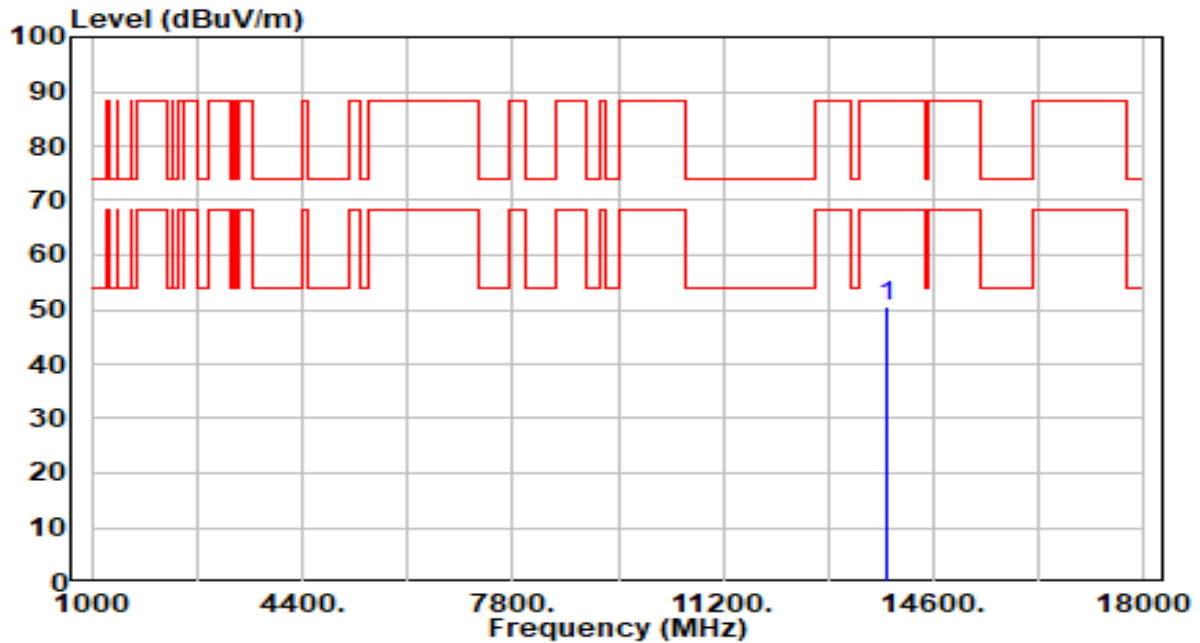

No	Frequency (MHz)	Reading (dBuV)	C.F (dB/m)	Measurement (dBuV/m)	Margin (dB)	Limit (dBuV/m)	Height (cm)	Angle (deg)	Remark (QP/PK/AV)
1	* 13850.000	44.20	6.55	50.75	-37.45	88.20	200	176	Peak

Note:

1. " *", means this data is the worst emission level.
2. C.F (Correction Factor) = Antenna Factor (dB/m)+ Cable Loss (dB) – Preamplifier(dB).
3. Measurement (dBuV/m) = Reading(dBuV) + C.F (Correction Factor).
4. The emission levels of other frequencies are very lower than the limit and not show in test report.

EUT	BE11000 Tri-Band Wi-Fi 7 Gaming Router	Date of Test	2024-01-16
Factor	DRH18-E	Temp. / Humidity	21°C /63%
Polarity	Vertical	Site / Test Engineer	AC2 / Marvin
Test Mode	802.11be-40MHz_TX_Band8_CH 195_ANT 0+1 Nss2	Test Voltage	AC 120V/60Hz

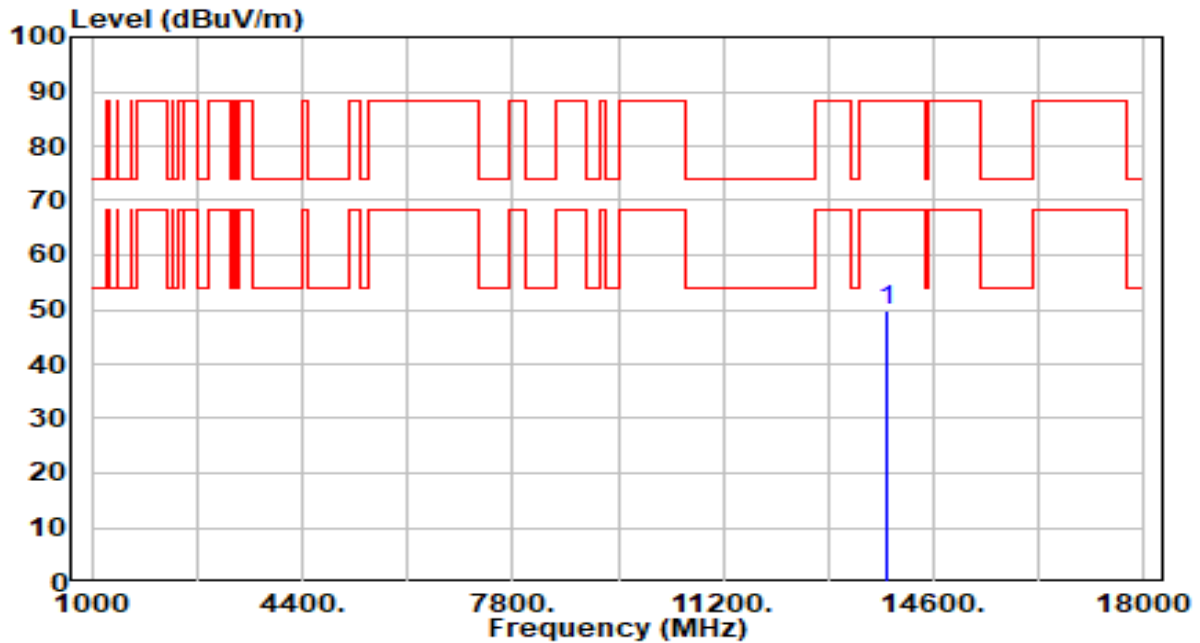

No	Frequency (MHz)	Reading (dBuV)	C.F (dB/m)	Measurement (dBuV/m)	Margin (dB)	Limit (dBuV/m)	Height (cm)	Angle (deg)	Remark (QP/PK/AV)
1	* 13850.000	43.12	6.55	49.67	-38.53	88.20	200	290	Peak

Note:

1. " *", means this data is the worst emission level.
2. C.F (Correction Factor) = Antenna Factor (dB/m)+ Cable Loss (dB) – Preamplifier(dB).
3. Measurement (dBuV/m) = Reading(dBuV) + C.F (Correction Factor).
4. The emission levels of other frequencies are very lower than the limit and not show in test report.

EUT	BE11000 Tri-Band Wi-Fi 7 Gaming Router	Date of Test	2024-01-16
Factor	DRH18-E	Temp. / Humidity	21°C /63%
Polarity	Horizontal	Site / Test Engineer	AC2 / Marvin
Test Mode	802.11be-40MHz_TX_Band8_CH 211_ANT 0+1 Nss2	Test Voltage	AC 120V/60Hz

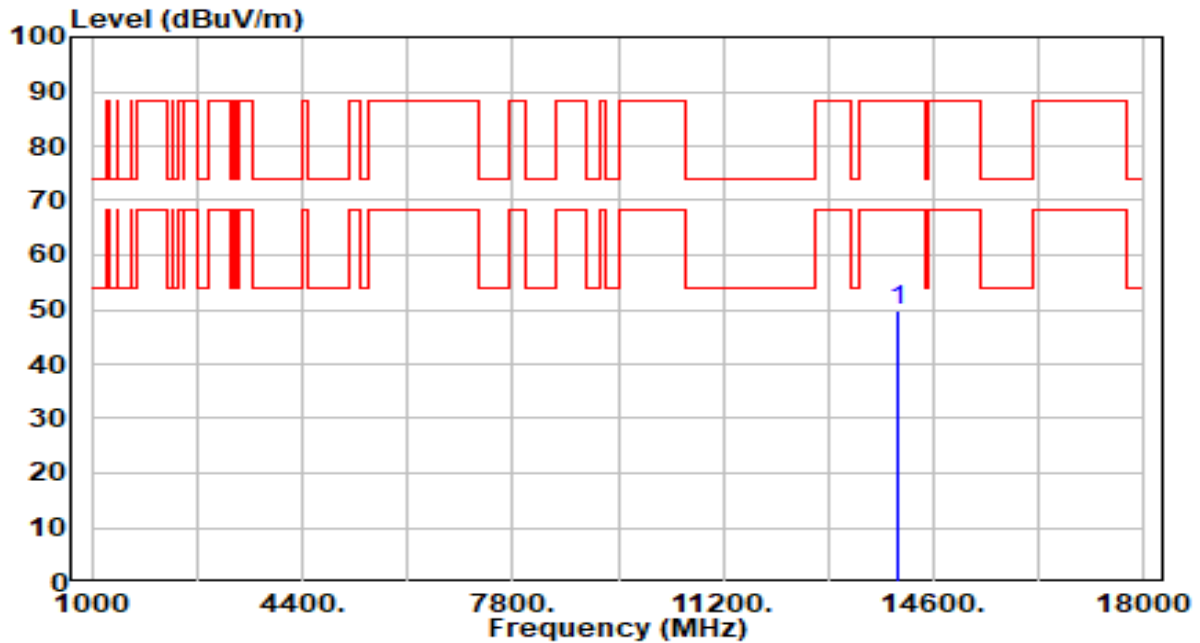

No	Frequency (MHz)	Reading (dBuV)	C.F (dB/m)	Measurement (dBuV/m)	Margin (dB)	Limit (dBuV/m)	Height (cm)	Angle (deg)	Remark (QP/PK/AV)
1	* 14010.000	43.31	6.62	49.93	-38.27	88.20	200	219	Peak

Note:

1. " *", means this data is the worst emission level.
2. C.F (Correction Factor) = Antenna Factor (dB/m)+ Cable Loss (dB) – Preamplifier(dB).
3. Measurement (dBuV/m) = Reading(dBuV) + C.F (Correction Factor).
4. The emission levels of other frequencies are very lower than the limit and not show in test report.

EUT	BE11000 Tri-Band Wi-Fi 7 Gaming Router	Date of Test	2024-01-16
Factor	DRH18-E	Temp. / Humidity	21°C /63%
Polarity	Vertical	Site / Test Engineer	AC2 / Marvin
Test Mode	802.11be-40MHz_TX_Band8_CH 211_ANT 0+1 Nss2	Test Voltage	AC 120V/60Hz

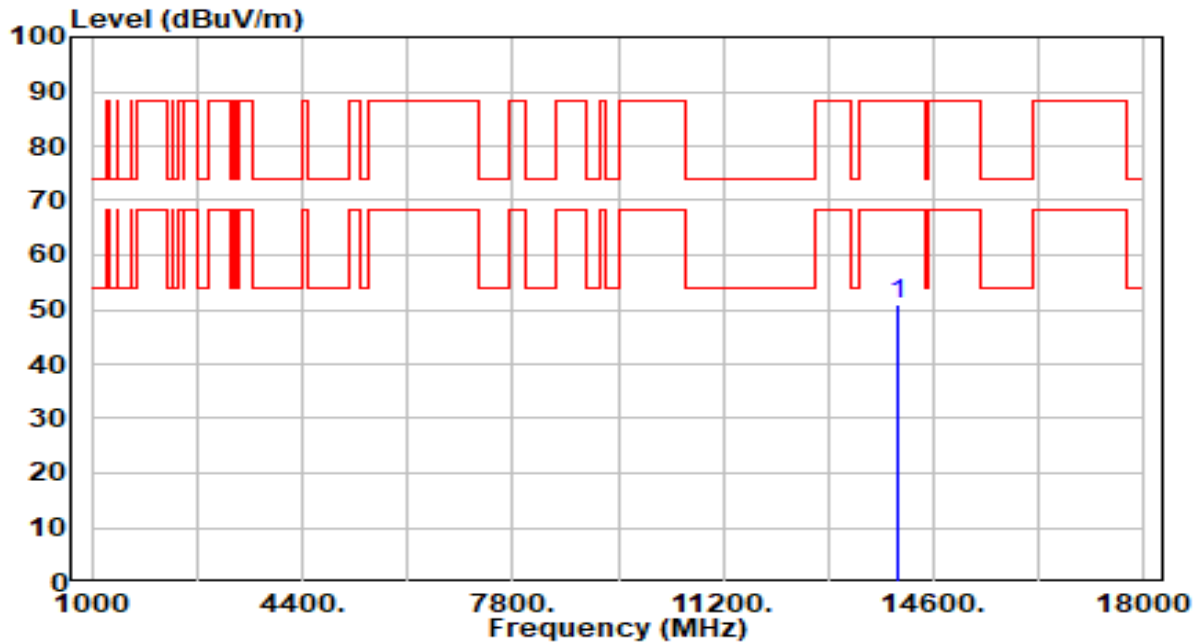

No	Frequency (MHz)	Reading (dBuV)	C.F (dB/m)	Measurement (dBuV/m)	Margin (dB)	Limit (dBuV/m)	Height (cm)	Angle (deg)	Remark (QP/PK/AV)
1	*	44.48	6.62	51.10	-37.10	88.20	200	269	Peak

Note:

1. " *", means this data is the worst emission level.
2. C.F (Correction Factor) = Antenna Factor (dB/m)+ Cable Loss (dB) – Preamplifier(dB).
3. Measurement (dBuV/m) = Reading(dBuV) + C.F (Correction Factor).
4. The emission levels of other frequencies are very lower than the limit and not show in test report.

EUT	BE11000 Tri-Band Wi-Fi 7 Gaming Router	Date of Test	2024-01-16
Factor	DRH18-E	Temp. / Humidity	21°C /63%
Polarity	Horizontal	Site / Test Engineer	AC2 / Marvin
Test Mode	802.11be-40MHz_TX_Band8_CH 227_ANT 0+1 Nss2	Test Voltage	AC 120V/60Hz

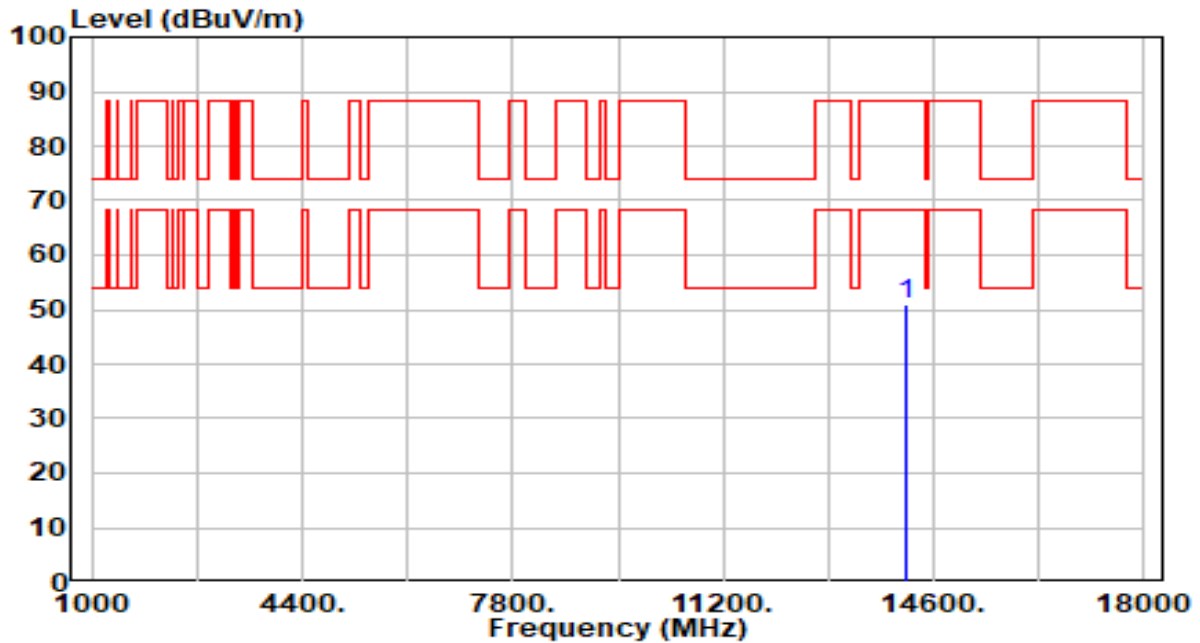

No	Frequency (MHz)	Reading (dBuV)	C.F (dB/m)	Measurement (dBuV/m)	Margin (dB)	Limit (dBuV/m)	Height (cm)	Angle (deg)	Remark (QP/PK/AV)
1	* 14170.000	44.35	6.65	51.01	-37.19	88.20	200	251	Peak

Note:

1. " *", means this data is the worst emission level.
2. C.F (Correction Factor) = Antenna Factor (dB/m)+ Cable Loss (dB) – Preamplifier(dB).
3. Measurement (dBuV/m) = Reading(dBuV) + C.F (Correction Factor).
4. The emission levels of other frequencies are very lower than the limit and not show in test report.

EUT	BE11000 Tri-Band Wi-Fi 7 Gaming Router	Date of Test	2024-01-16
Factor	DRH18-E	Temp. / Humidity	21°C /63%
Polarity	Vertical	Site / Test Engineer	AC2 / Marvin
Test Mode	802.11be-40MHz_TX_Band8_CH 227_ANT 0+1 Nss2	Test Voltage	AC 120V/60Hz

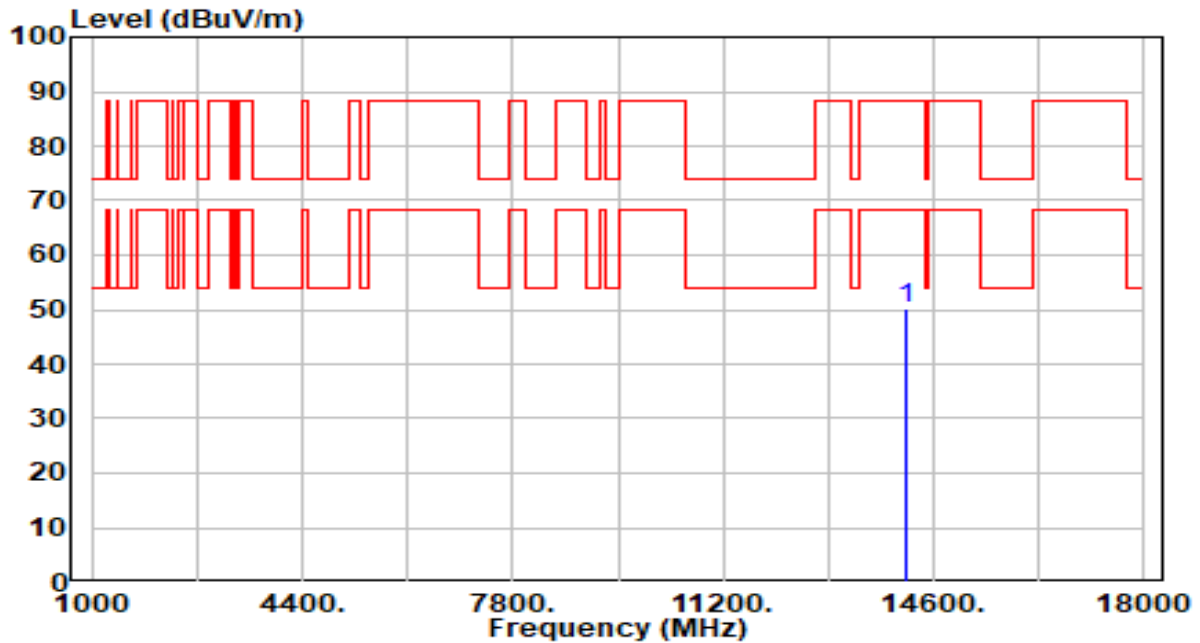

No	Frequency (MHz)	Reading (dBuV)	C.F (dB/m)	Measurement (dBuV/m)	Margin (dB)	Limit (dBuV/m)	Height (cm)	Angle (deg)	Remark (QP/PK/AV)
1	* 14170.000	43.66	6.65	50.31	-37.89	88.20	200	129	Peak

Note:

1. " *", means this data is the worst emission level.
2. C.F (Correction Factor) = Antenna Factor (dB/m)+ Cable Loss (dB) – Preamplifier(dB).
3. Measurement (dBuV/m) = Reading(dBuV) + C.F (Correction Factor).
4. The emission levels of other frequencies are very lower than the limit and not show in test report.

EUT	BE11000 Tri-Band Wi-Fi 7 Gaming Router	Date of Test	2024-01-16
Factor	DRH18-E	Temp. / Humidity	21°C /63%
Polarity	Horizontal	Site / Test Engineer	AC2 / Marvin
Test Mode	802.11be-80MHz_TX_Band5_CH 7_ANT 0+1 Nss2	Test Voltage	AC 120V/60Hz

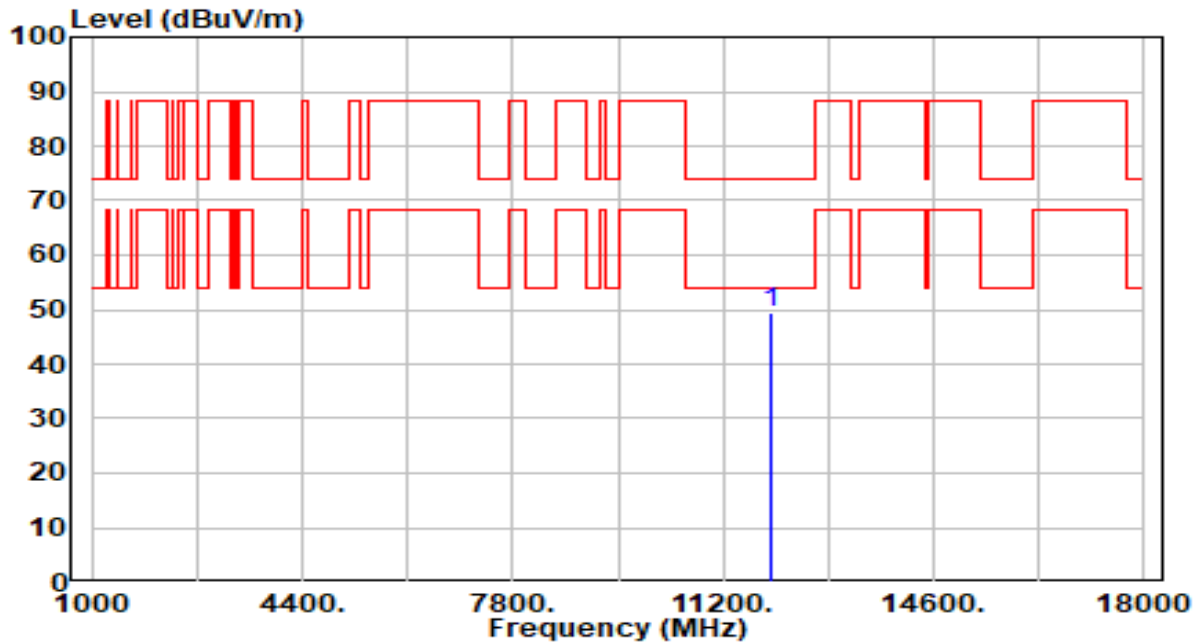

No	Frequency (MHz)	Reading (dBuV)	C.F (dB/m)	Measurement (dBuV/m)	Margin (dB)	Limit (dBuV/m)	Height (cm)	Angle (deg)	Remark (QP/PK/AV)
1	* 11970.000	43.99	5.46	49.45	-24.55	74.00	200	236	Peak

Note:

1. " *", means this data is the worst emission level.
2. C.F (Correction Factor) = Antenna Factor (dB/m)+ Cable Loss (dB) – Preamplifier(dB).
3. Measurement (dBuV/m) = Reading(dBuV) + C.F (Correction Factor).
4. The emission levels of other frequencies are very lower than the limit and not show in test report.

EUT	BE11000 Tri-Band Wi-Fi 7 Gaming Router	Date of Test	2024-01-16
Factor	DRH18-E	Temp. / Humidity	21°C /63%
Polarity	Vertical	Site / Test Engineer	AC2 / Marvin
Test Mode	802.11be-80MHz_TX_Band5_CH 7_ANT 0+1 Nss2	Test Voltage	AC 120V/60Hz

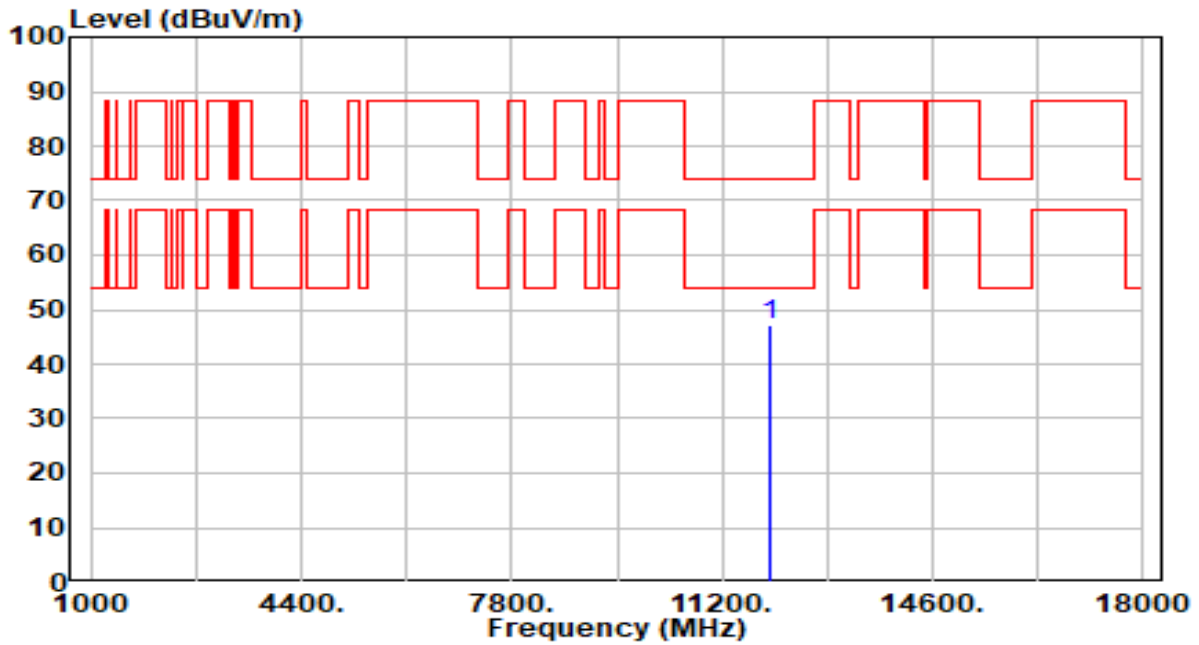

No	Frequency (MHz)	Reading (dBuV)	C.F (dB/m)	Measurement (dBuV/m)	Margin (dB)	Limit (dBuV/m)	Height (cm)	Angle (deg)	Remark (QP/PK/AV)
1	* 11970.000	41.69	5.46	47.15	-26.85	74.00	200	86	Peak

Note:

1. " *", means this data is the worst emission level.
2. C.F (Correction Factor) = Antenna Factor (dB/m)+ Cable Loss (dB) – Preamplifier(dB).
3. Measurement (dBuV/m) = Reading(dBuV) + C.F (Correction Factor).
4. The emission levels of other frequencies are very lower than the limit and not show in test report.

EUT	BE11000 Tri-Band Wi-Fi 7 Gaming Router	Date of Test	2024-01-16
Factor	DRH18-E	Temp. / Humidity	21°C /63%
Polarity	Horizontal	Site / Test Engineer	AC2 / Marvin
Test Mode	802.11be-80MHz_TX_Band5_CH 39_ANT 0+1 Nss2	Test Voltage	AC 120V/60Hz

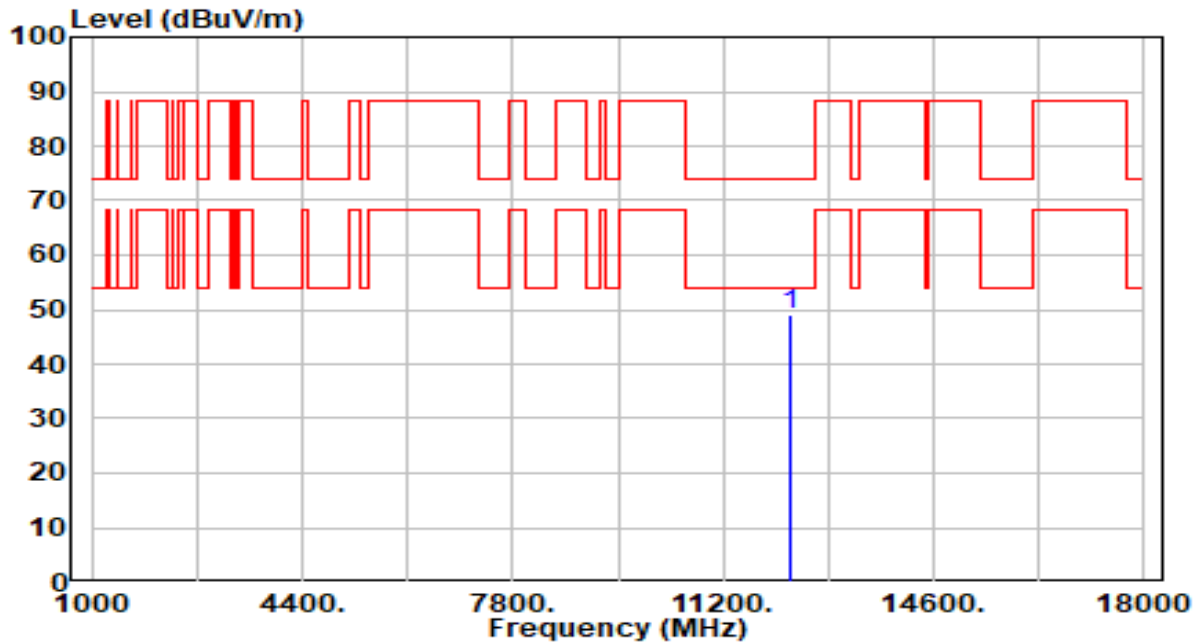

No	Frequency (MHz)	Reading (dBuV)	C.F (dB/m)	Measurement (dBuV/m)	Margin (dB)	Limit (dBuV/m)	Height (cm)	Angle (deg)	Remark (QP/PK/AV)
1	*	43.11	6.01	49.12	-24.88	74.00	200	150	Peak

Note:

1. " *", means this data is the worst emission level.
2. C.F (Correction Factor) = Antenna Factor (dB/m)+ Cable Loss (dB) – Preamplifier(dB).
3. Measurement (dBuV/m) = Reading(dBuV) + C.F (Correction Factor).
4. The emission levels of other frequencies are very lower than the limit and not show in test report.

EUT	BE11000 Tri-Band Wi-Fi 7 Gaming Router	Date of Test	2024-01-16
Factor	DRH18-E	Temp. / Humidity	21°C /63%
Polarity	Vertical	Site / Test Engineer	AC2 / Marvin
Test Mode	802.11be-80MHz_TX_Band5_CH 39_ANT 0+1 Nss2	Test Voltage	AC 120V/60Hz

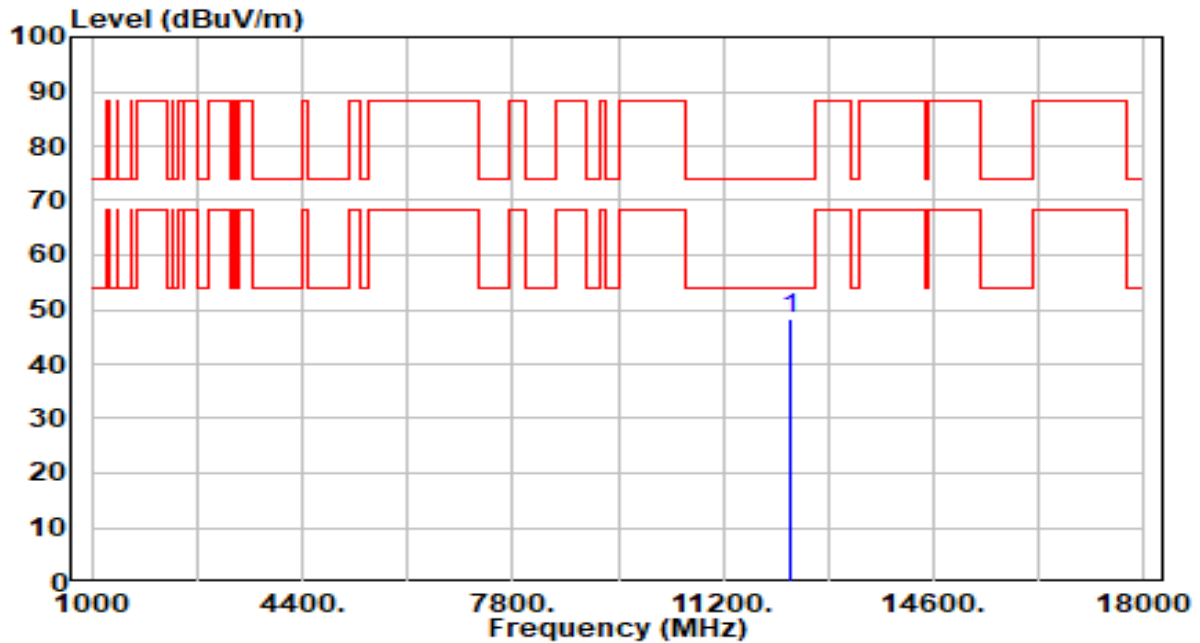

No	Frequency (MHz)	Reading (dBuV)	C.F (dB/m)	Measurement (dBuV/m)	Margin (dB)	Limit (dBuV/m)	Height (cm)	Angle (deg)	Remark (QP/PK/AV)
1	*	42.19	6.01	48.20	-25.80	74.00	200	27	Peak

Note:

1. " *", means this data is the worst emission level.
2. C.F (Correction Factor) = Antenna Factor (dB/m)+ Cable Loss (dB) – Preamplifier(dB).
3. Measurement (dBuV/m) = Reading(dBuV) + C.F (Correction Factor).
4. The emission levels of other frequencies are very lower than the limit and not show in test report.