

### 802.11 n20 CH01 (2412MHz)

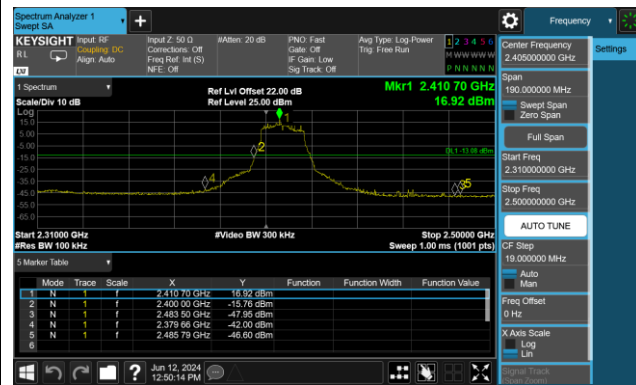

### 802.11 n20 CH01 (2412MHz)

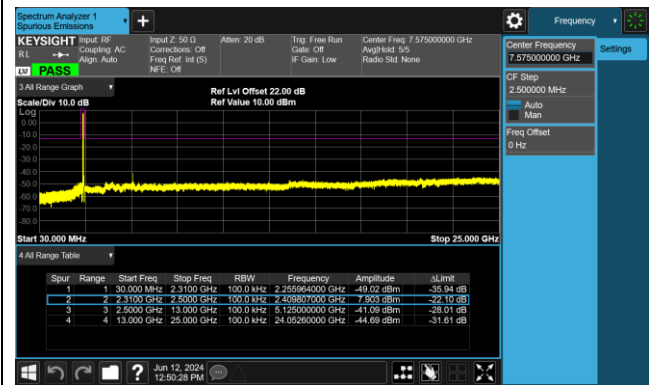

### 802.11 n20 CH06 (2437MHz)

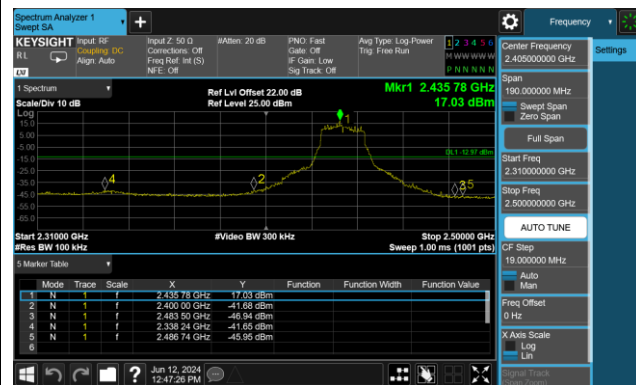

### 802.11 n20 CH06 (2437MHz)

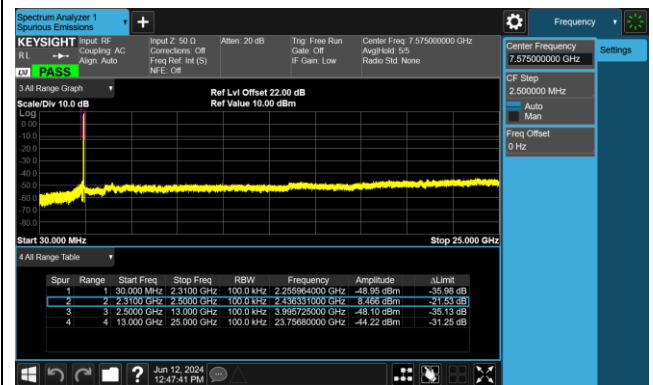

### 802.11 n20 CH11 (2462MHz)



### 802.11 n20 CH11 (2462MHz)

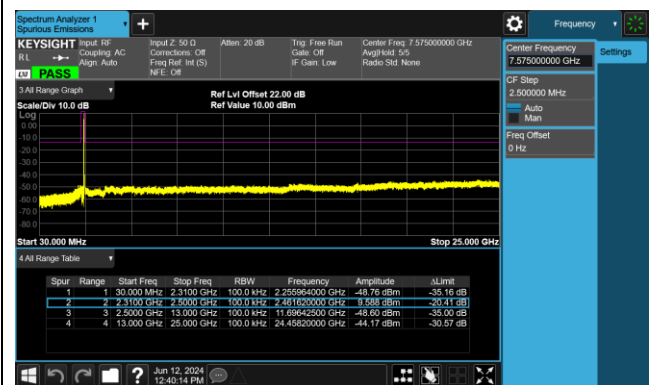

### 802.11 n40 CH03 (2422MHz)

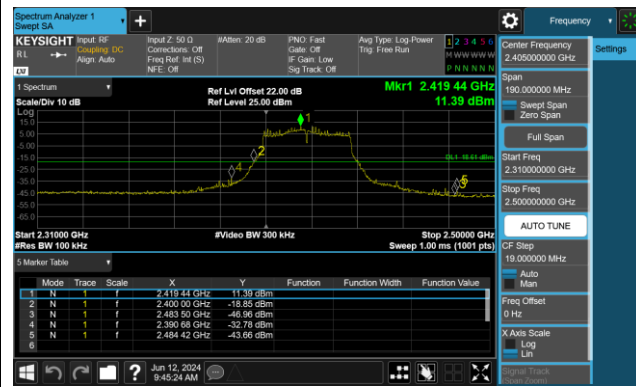

### 802.11 n40 CH03 (2422MHz)

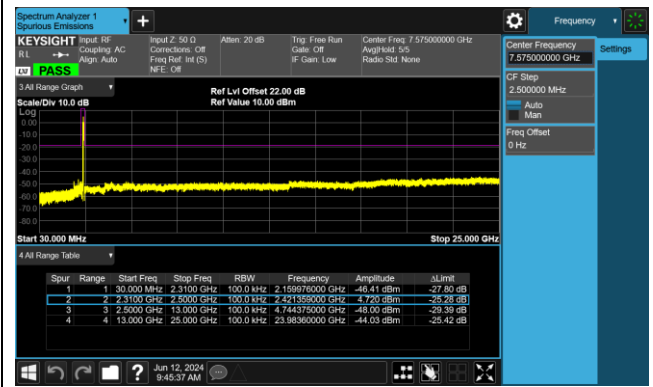

### 802.11 n40 CH06 (2437MHz)



### 802.11 n40 CH06 (2437MHz)

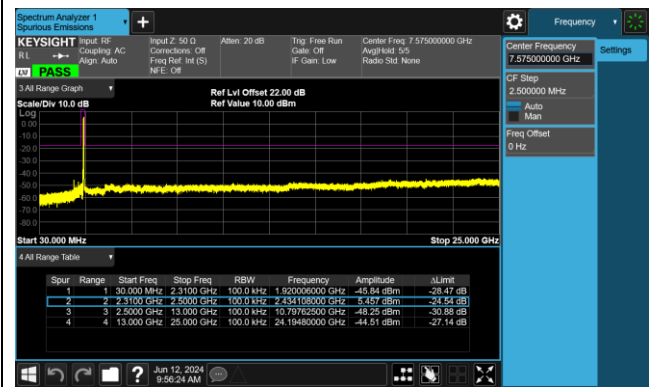

### 802.11 n40 CH09 (2452MHz)



### 802.11 n40 CH09 (2452MHz)

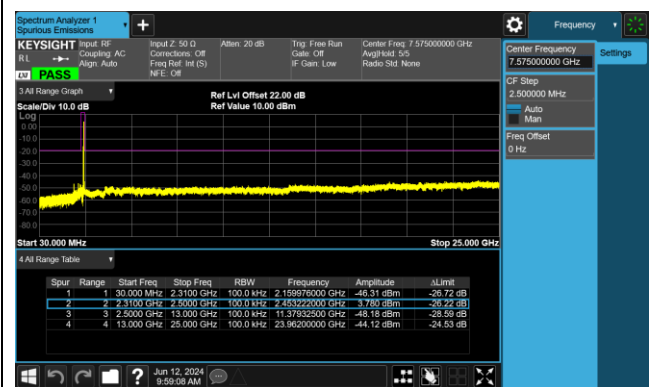

### 802.11 ax20 CH01 (2412MHz)

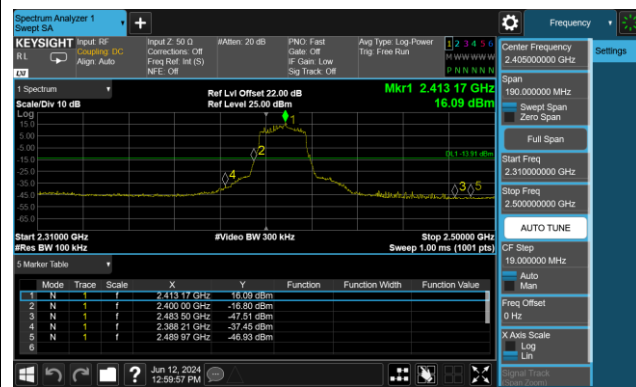

### 802.11 ax20 CH01 (2412MHz)

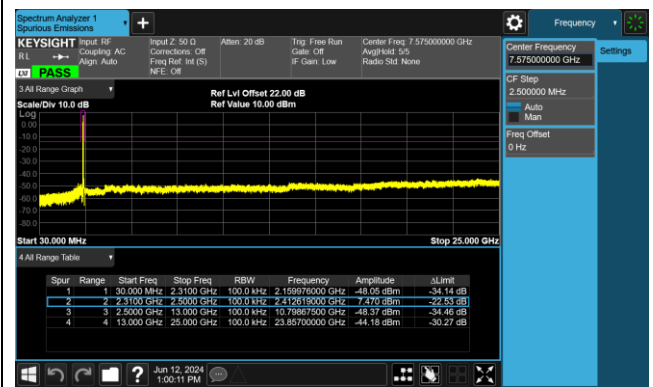

### 802.11 ax20 CH06 (2437MHz)

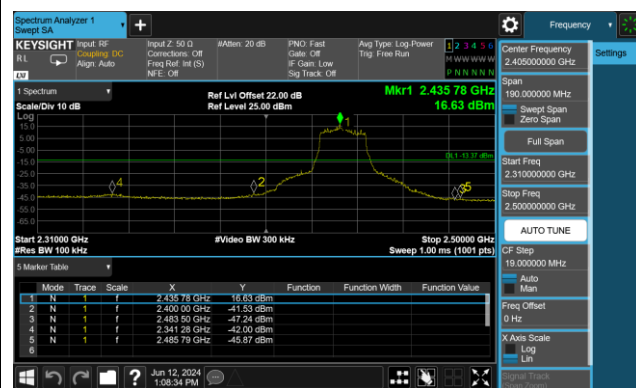

### 802.11 ax20 CH06 (2437MHz)

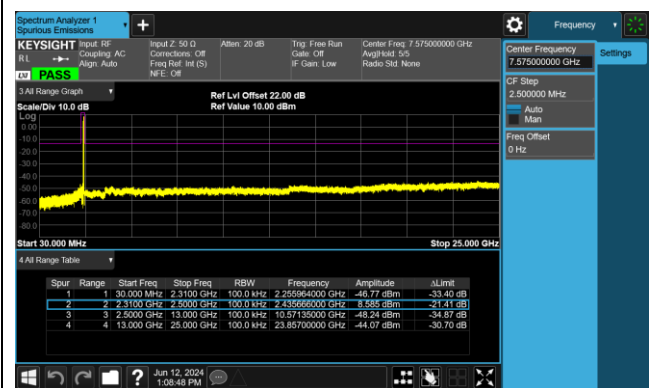

### 802.11 ax20 CH11 (2462MHz)

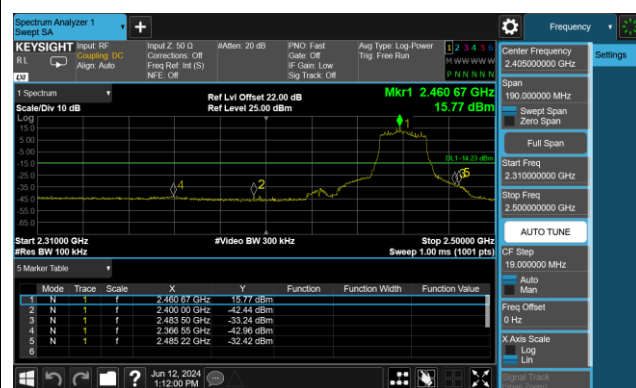

### 802.11 ax20 CH11 (2462MHz)

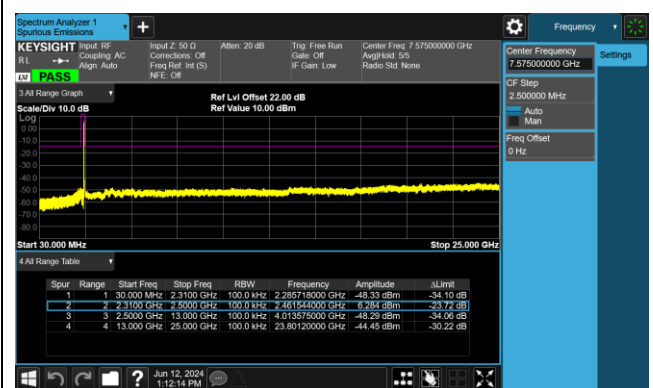

### 802.11 ax40 CH03 (2422MHz)

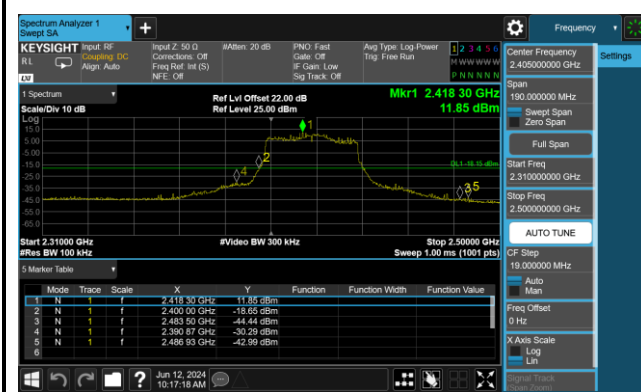

### 802.11 ax40 CH03 (2422MHz)

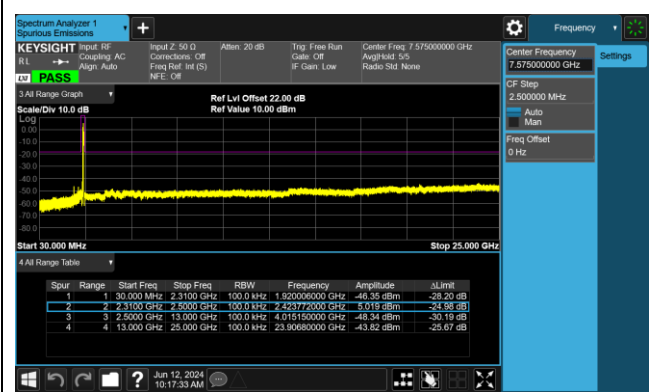

### 802.11 ax40 CH06 (2437MHz)

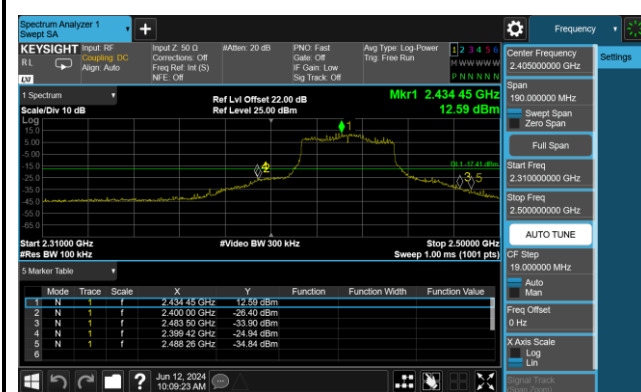

### 802.11 ax40 CH06 (2437MHz)

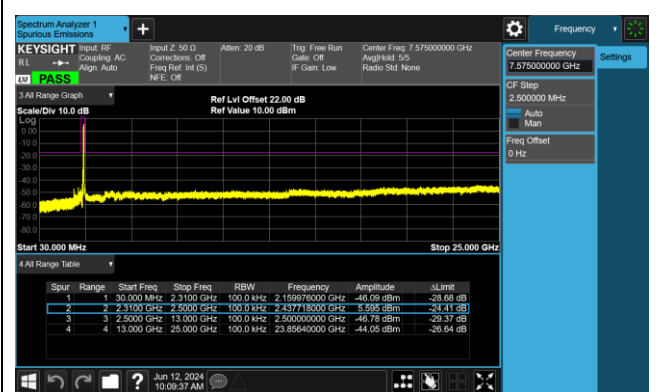

### 802.11 ax40 CH09 (2452MHz)

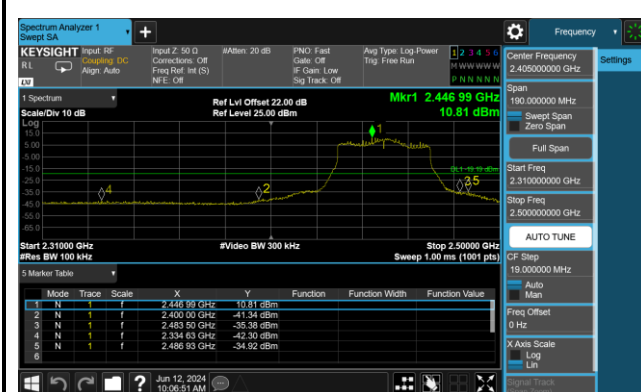

### 802.11 ax40 CH09 (2452MHz)

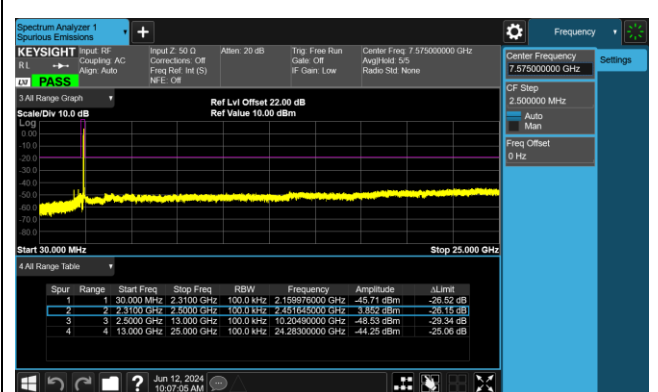

### 802.11be20 CH01 (2412MHz)

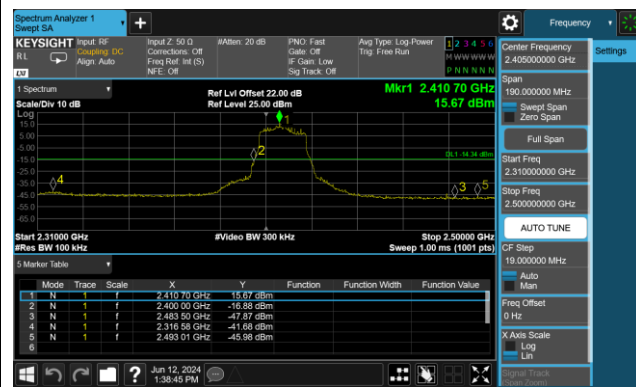

### 802.11be20 CH01 (2412MHz)

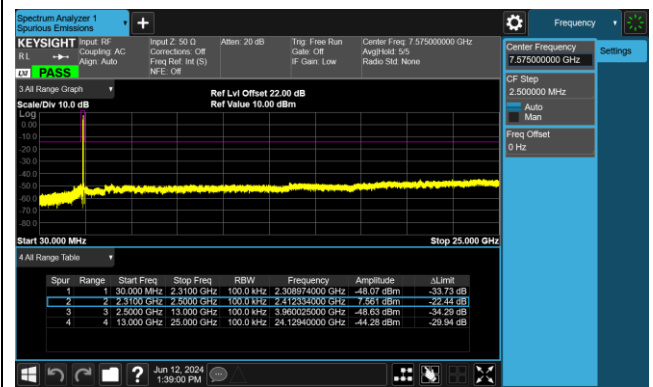

### 802.11be20 CH06 (2437MHz)

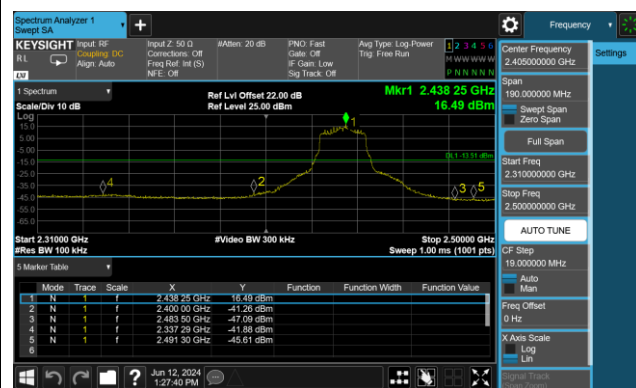

### 802.11be20 CH06 (2437MHz)

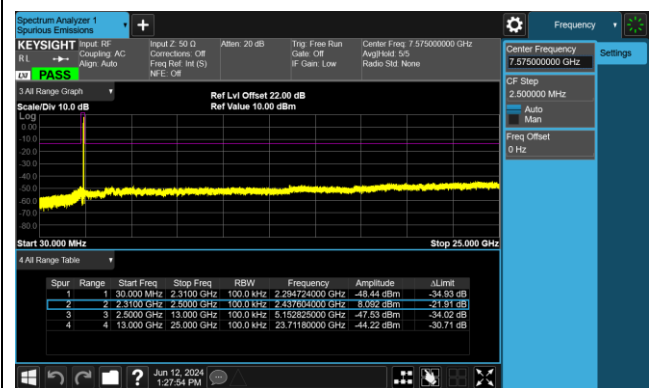

### 802.11be20 CH11 (2462MHz)

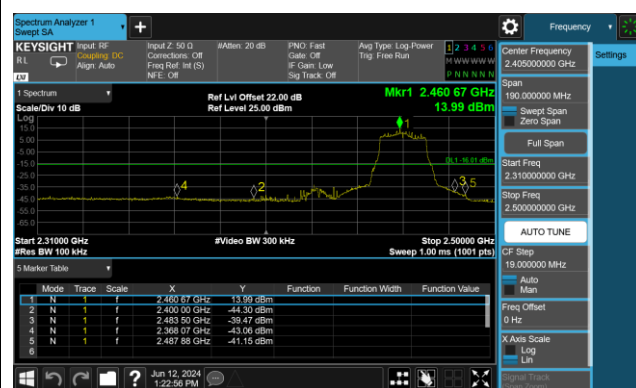

### 802.11be20 CH11 (2462MHz)

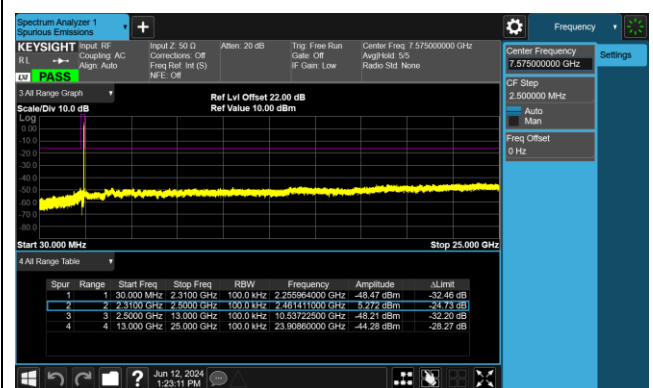

### 802.11be40 CH03 (2422MHz)

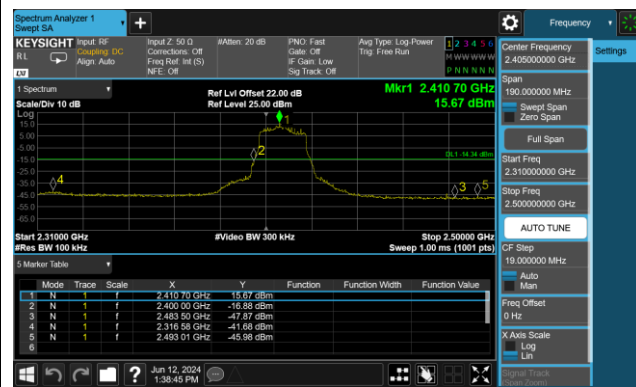

### 802.11be40 CH03 (2422MHz)

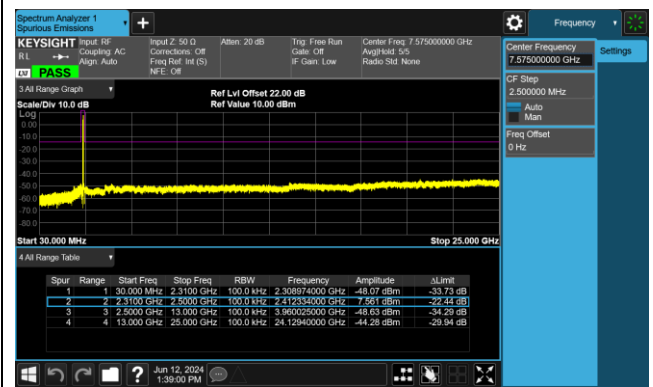

### 802.11be40 CH06 (2437MHz)

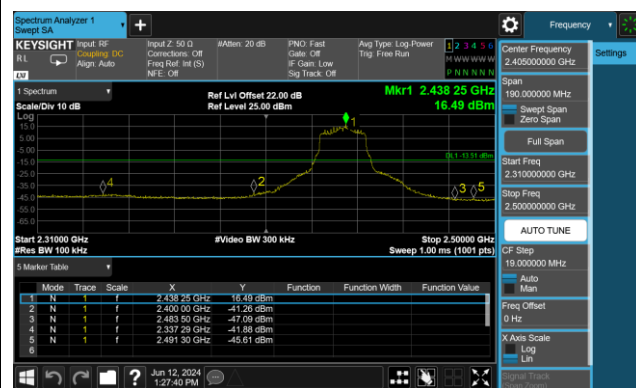

### 802.11be40 CH06 (2437MHz)

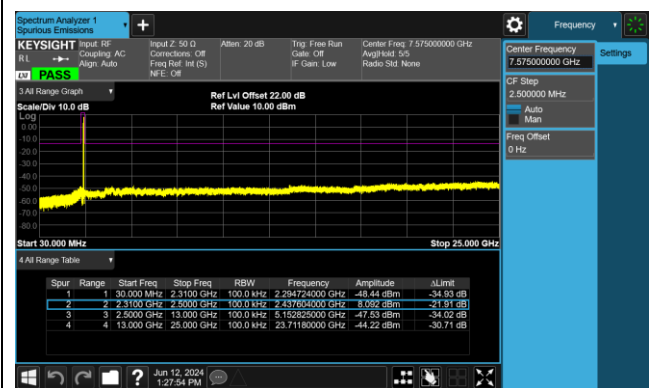

### 802.11be40 CH09 (2452MHz)

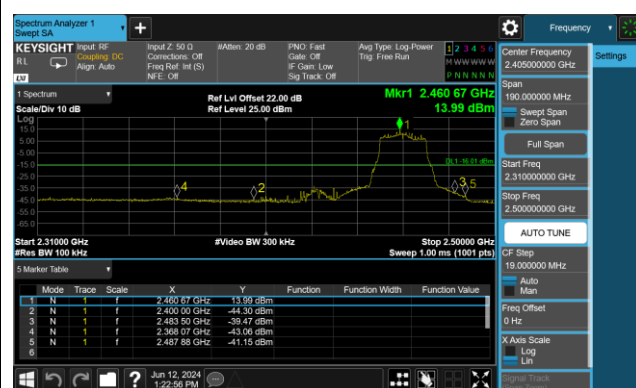

### 802.11be40 CH09 (2452MHz)

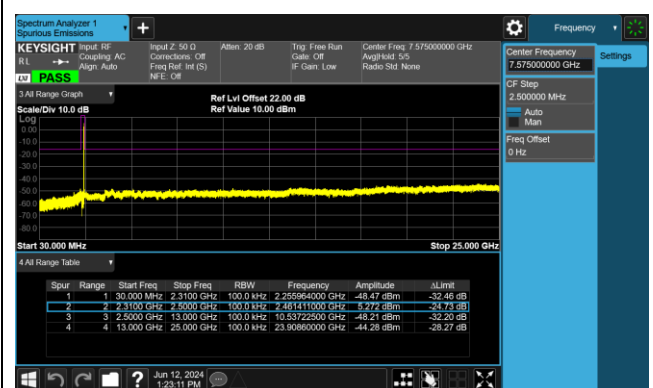

## 7.6. Radiated Spurious Emission Measurement

### 7.6.1. Test Limit

All out of band emissions appearing in a restricted band as specified in Section 15.205 of the Title 47CFR must not exceed the limits shown in Table per Section 15.209.

FCC Part 15 Subpart C Paragraph 15.209		
Frequency [MHz]	Field Strength [Uv/m]	Measured Distance [Meters]
0.009 - 0.490	2400/F (kHz)	300
0.490 - 1.705	24000/F (kHz)	30
1.705 - 30	30	30
30 - 88	100	3
88 - 216	150	3
216 - 960	200	3
Above 960	500	3

### 7.6.2. Test Procedure Used

ANSI C63.10 - 2013 Section 6.3 (General Requirements)

ANSI C63.10 - 2013 Section 6.4 (Standard test method below 30MHz)

ANSI C63.10 - 2013 Section 6.5 (Standard test method above 30MHz to 1GHz)

ANSI C63.10 - 2013 Section 6.6 (Standard test method above 1GHz)

### 7.6.3. Test Setting

**Table 1 - RBW as a function of frequency**

Frequency	RBW
9 ~ 150 kHz	200 ~ 300 Hz
0.15 ~ 30 MHz	9 ~ 10 kHz
30 ~ 1000 MHz	100 ~ 120 kHz
> 1000MHz	1MHz

**Quasi-Peak Measurements below 1GHz**

1. Analyzer center frequency was set to the frequency of the radiated spurious emission of interest
2. Span was set greater than 1MHz
3. RBW = as specified in Table 1
4. Detector = CISPR quasi-peak
5. Sweep time = auto couple
6. Trace was allowed to stabilize

**Peak Measurements above 1GHz**

1. Analyzer center frequency was set to the frequency of the radiated spurious emission of interest
2. RBW = 1MHz
3. VBW = 3MHz
4. Detector = peak
5. Sweep time = auto couple
6. Trace mode = max hold
7. Trace was allowed to stabilize

**Average Measurements above 1GHz (Method VB)**

1. Analyzer center frequency was set to the frequency of the radiated spurious emission of interest
2. RBW = 1MHz
3. VBW; If the EUT is configured to transmit with duty cycle  $\geq 98\%$ , set VBW = 10 Hz.  
If the EUT duty cycle is  $< 98\%$ , set VBW  $\geq 1/T$ . T is the minimum transmission duration.
4. Detector = Peak
5. Sweep time = auto
6. Trace mode = max hold
7. Trace was allowed to stabilize



### 7.6.4. Test Setup

#### Below 1GHz Test Setup:

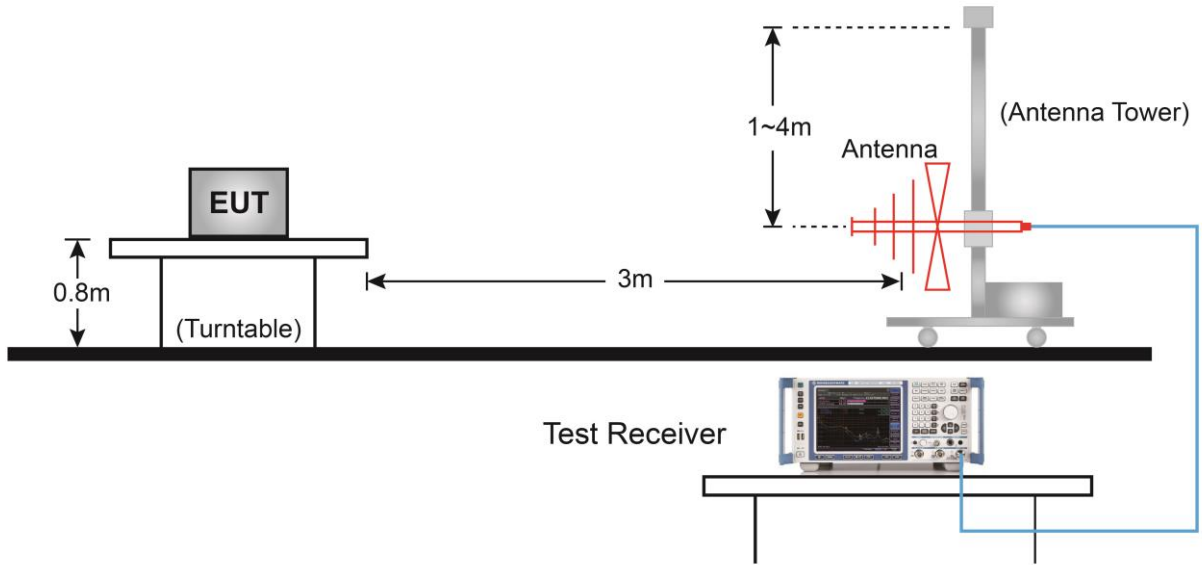

#### Above 1GHz Test Setup:

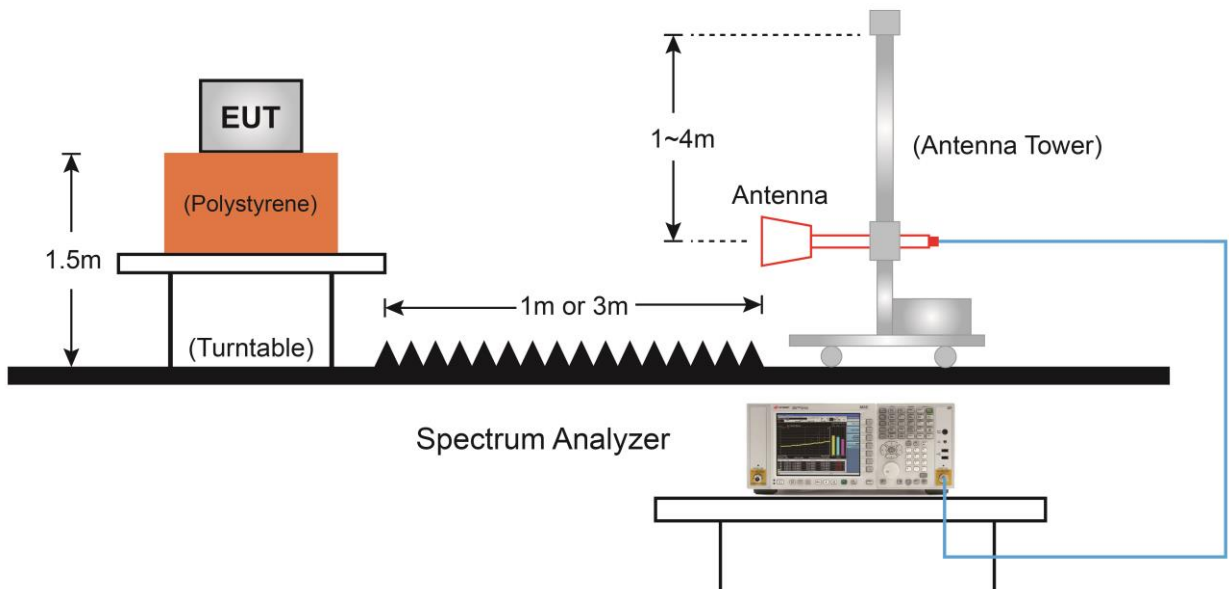

### 7.6.5. Test Result

EUT	BE11000 Ceiling Mount Wi-Fi 7 Access Point	Date of Test	2024-05-28
Factor	VULB 9162	Temp. / Humidity	22°C /61%
Polarity	Horizontal	Site / Test Engineer	AC2 / You
Test Mode	802.11n-20MHz_TX_CH 6_ANT 0+1	Test Voltage	AC 120V/60Hz

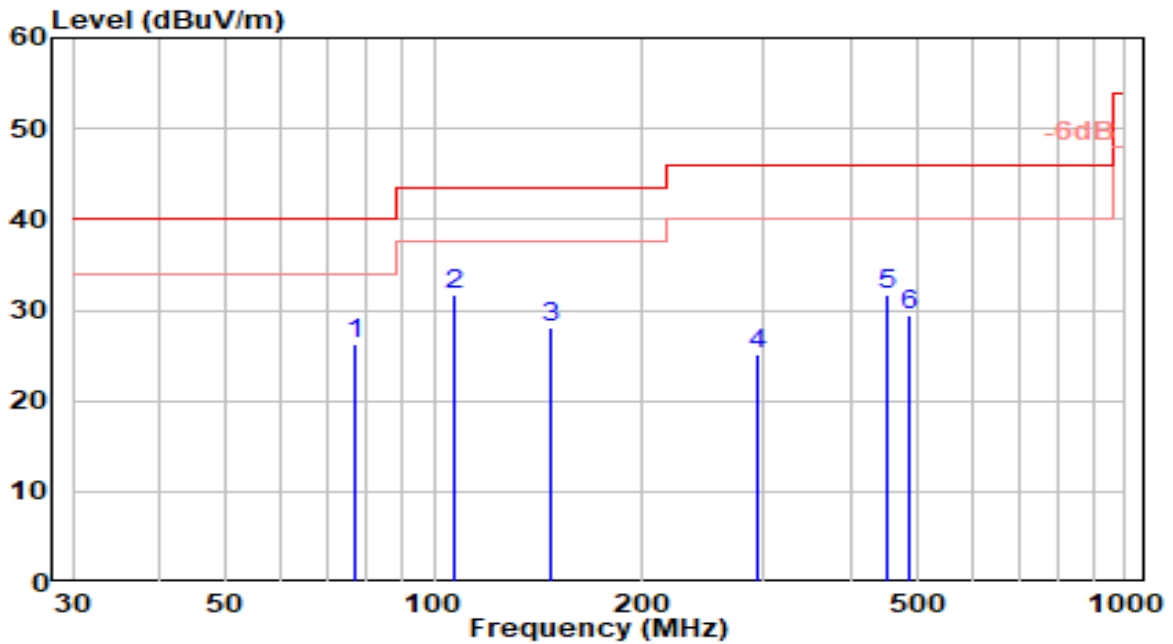

No	Frequency (MHz)	Reading (dBuV)	C.F (dB/m)	Measurement (dBuV/m)	Margin (dB)	Limit (dBuV/m)	Height (cm)	Angle (deg)	Remark (QP/PK/AV)
1	77.051	11.81	14.35	26.17	-13.83	40.00	200	25	QP
2	* 106.759	13.38	18.36	31.73	-11.77	43.50	200	99	QP
3	147.921	12.90	15.07	27.97	-15.53	43.50	200	287	QP
4	293.084	4.51	20.51	25.02	-20.98	46.00	100	112	QP
5	454.310	7.69	23.92	31.61	-14.39	46.00	200	45	QP
6	489.027	4.80	24.75	29.55	-16.45	46.00	200	134	QP

Note:

- "\*" means this data is the worst emission level.
- C.F (Correction Factor) = Antenna Factor (dB/m) + Cable Loss (dB).
- Measurement (dBuV/m) = Reading(dBuV) + C.F (Correction Factor).
- The emission levels of other frequencies are very lower than the limit and not show in test report.
- The amplitude of radiated emissions (frequency range from 9kHz to 30MHz) is that proximity to ambient noise, which also are attenuated more than 20dB below the permissible value. Therefore, the data is not presented in the report.

EUT	BE11000 Ceiling Mount Wi-Fi 7 Access Point	Date of Test	2024-05-29
Factor	VULB 9162	Temp. / Humidity	22°C /61%
Polarity	Vertical	Site / Test Engineer	AC2 / You
Test Mode	802.11n-20MHz_TX_CH 6_ANT 0+1	Test Voltage	AC 120V/60Hz

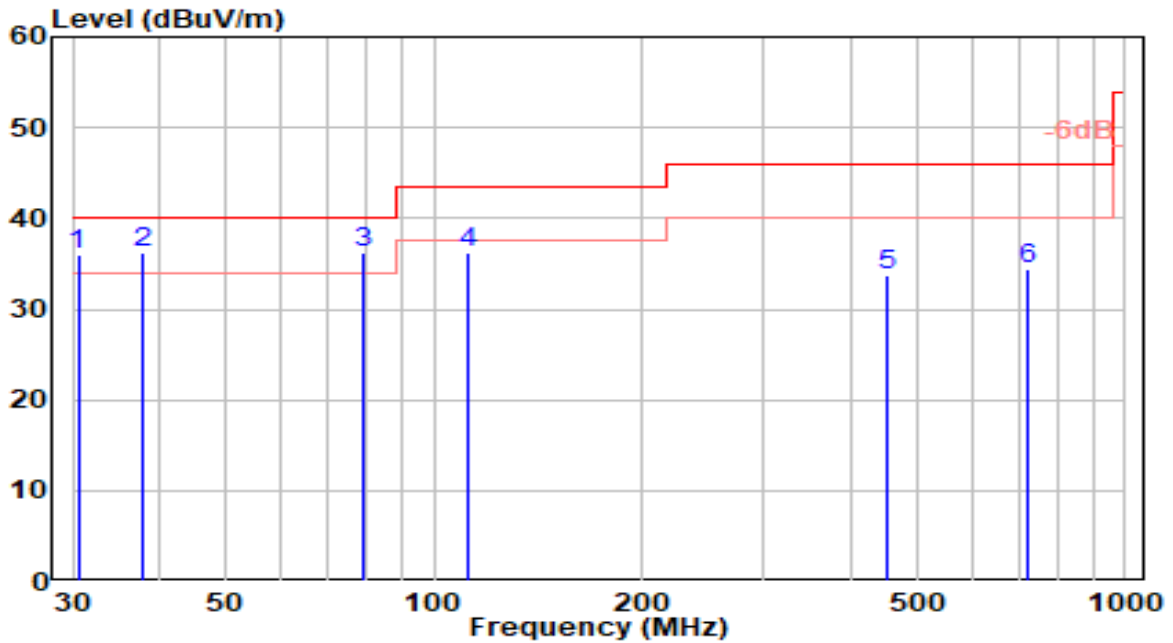

No	Frequency (MHz)	Reading (dBuV)	C.F (dB/m)	Measurement (dBuV/m)	Margin (dB)	Limit (dBuV/m)	Height (cm)	Angle (deg)	Remark (QP/PK/AV)
1	30.531	19.60	16.37	35.97	-4.03	40.00	100	75	QP
2	* 37.812	17.39	18.90	36.28	-3.72	40.00	100	0	QP
3	79.243	22.23	13.96	36.19	-3.81	40.00	100	60	QP
4	111.738	18.13	18.11	36.24	-7.26	43.50	100	21	QP
5	452.720	9.77	23.88	33.65	-12.35	46.00	100	30	QP
6	721.726	5.87	28.50	34.37	-11.63	46.00	100	222	QP

Note:

- "\*" means this data is the worst emission level.
- C.F (Correction Factor) = Antenna Factor (dB/m) + Cable Loss (dB).
- Measurement (dBuV/m) = Reading(dBuV) + C.F (Correction Factor).
- The emission levels of other frequencies are very lower than the limit and not show in test report.
- The amplitude of radiated emissions (frequency range from 9kHz to 30MHz) is that proximity to ambient noise, which also are attenuated more than 20dB below the permissible value. Therefore, the data is not presented in the report.

EUT	BE11000 Ceiling Mount Wi-Fi 7 Access Point	Date of Test	2024-05-28
Factor	DRH18-E	Temp. / Humidity	20°C /65%
Polarity	Horizontal	Site / Test Engineer	AC2 / You
Test Mode	802.11b_TX_CH 1 ANT 0+1	Test Voltage	AC 120V/60Hz

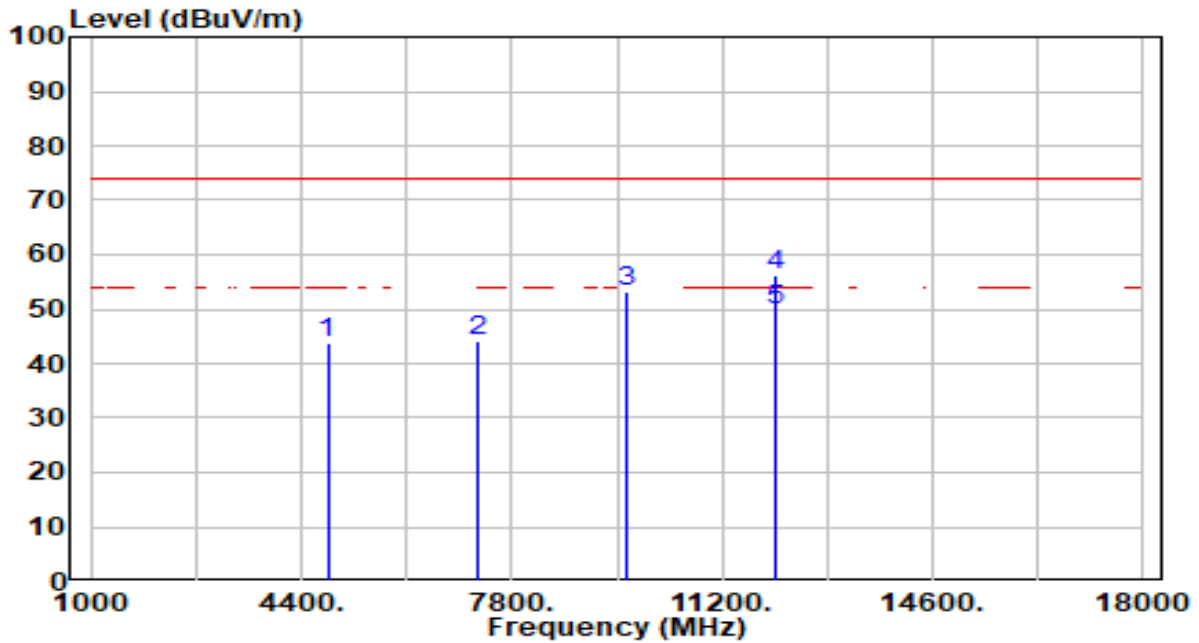

No	Frequency (MHz)	Reading (dBuV)	C.F (dB/m)	Measurement (dBuV/m)	Margin (dB)	Limit (dBuV/m)	Height (cm)	Angle (deg)	Remark (QP/PK/AV)
1	4824.000	43.52	0.23	43.75	-30.25	74.00	100	177	Peak
2	7236.000	38.52	5.54	44.07	-29.93	74.00	100	196	Peak
3	9648.000	47.74	5.30	53.04	-20.96	74.00	100	231	Peak
4	12060.000	50.52	5.61	56.13	-17.87	74.00	100	122	Peak
5	* 12060.000	44.32	5.61	49.93	-4.07	54.00	100	122	Average

Note:

- " \*", means this data is the worst emission level.
- C.F (Correction Factor) = Antenna Factor (dB/m) + Cable Loss (dB) – Preamplifier(dB).
- Measurement (dBuV/m) = Reading(dBuV) + C.F (Correction Factor).
- The emission levels of other frequencies are very lower than the limit and not show in test report.

EUT	BE11000 Ceiling Mount Wi-Fi 7 Access Point	Date of Test	2024-05-27
Factor	DRH18-E	Temp. / Humidity	20°C /65%
Polarity	Vertical	Site / Test Engineer	AC2 / You
Test Mode	802.11b_TX_CH 1 ANT 0+1	Test Voltage	AC 120V/60Hz

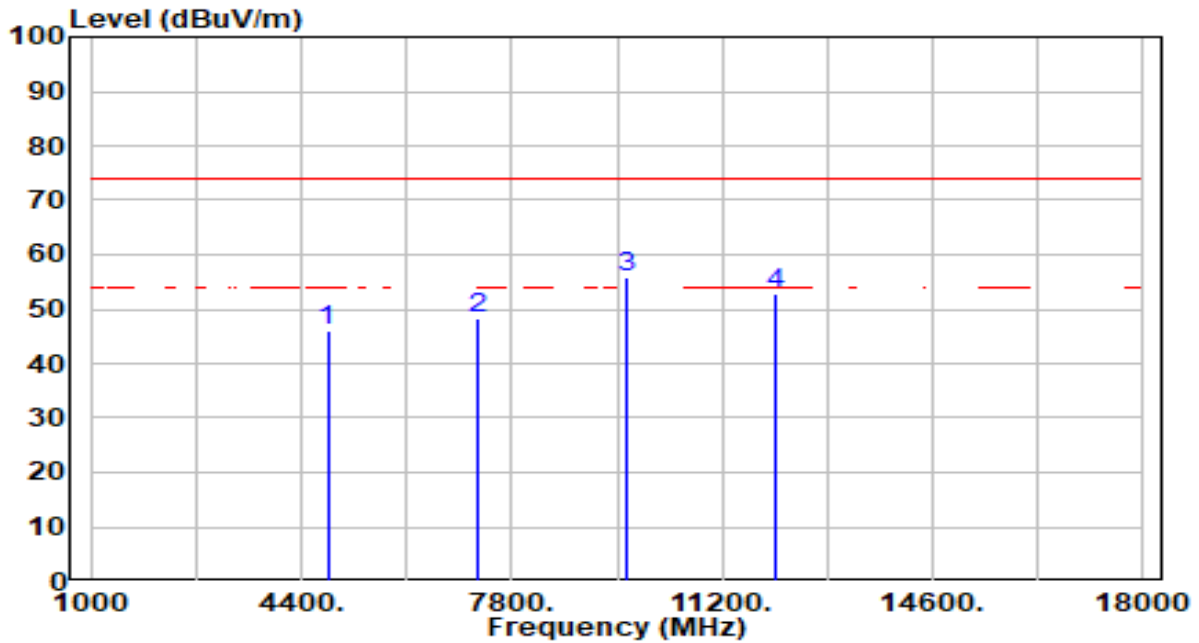

No	Frequency (MHz)	Reading (dBuV)	C.F (dB/m)	Measurement (dBuV/m)	Margin (dB)	Limit (dBuV/m)	Height (cm)	Angle (deg)	Remark (QP/PK/AV)
1	4824.000	45.87	0.23	46.11	-27.89	74.00	200	179	Peak
2	7236.000	42.75	5.54	48.29	-25.71	74.00	200	216	Peak
3	* 9648.000	50.51	5.30	55.82	-18.18	74.00	200	182	Peak
4	12059.000	47.26	5.61	52.87	-21.13	74.00	200	140	Peak

Note:

- "\*" means this data is the worst emission level.
- C.F (Correction Factor) = Antenna Factor (dB/m) + Cable Loss (dB) – Pre-amplifier(dB).
- Measurement (dBuV/m) = Reading(dBuV) + C.F (Correction Factor).
- The emission levels of other frequencies are very lower than the limit and not show in test report.

EUT	BE11000 Ceiling Mount Wi-Fi 7 Access Point	Date of Test	2024-05-27
Factor	DRH18-E	Temp. / Humidity	20°C /65%
Polarity	Horizontal	Site / Test Engineer	AC2 / You
Test Mode	802.11b_TX_CH 6 ANT 0+1	Test Voltage	AC 120V/60Hz

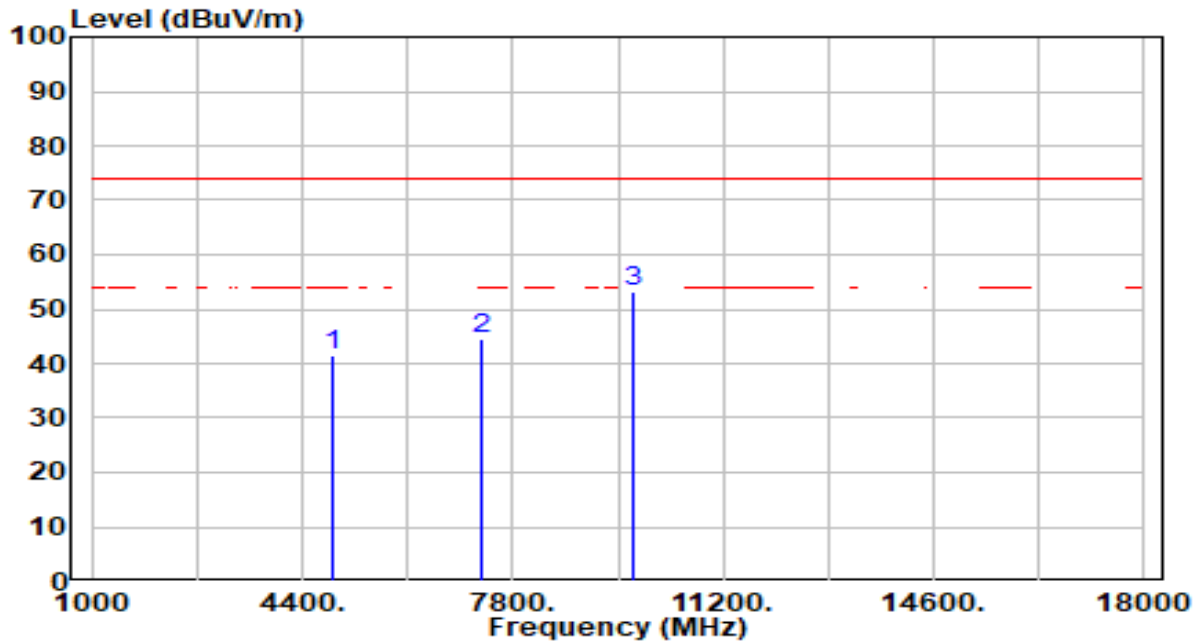

No	Frequency (MHz)	Reading (dBuV)	C.F (dB/m)	Measurement (dBuV/m)	Margin (dB)	Limit (dBuV/m)	Height (cm)	Angle (deg)	Remark (QP/PK/AV)
1	4874.000	41.04	0.36	41.40	-32.60	74.00	100	185	Peak
2	7311.000	38.77	5.59	44.36	-29.64	74.00	100	288	Peak
3	* 9748.000	48.03	5.34	53.38	-20.62	74.00	100	231	Peak

Note:

1. " \*", means this data is the worst emission level.
2. C.F (Correction Factor) = Antenna Factor (dB/m) + Cable Loss (dB) – Preamplifier(dB).
3. Measurement (dBuV/m) = Reading(dBuV) + C.F (Correction Factor).
4. The emission levels of other frequencies are very lower than the limit and not show in test report.

EUT	BE11000 Ceiling Mount Wi-Fi 7 Access Point	Date of Test	2024-05-27
Factor	DRH18-E	Temp. / Humidity	20°C /65%
Polarity	Vertical	Site / Test Engineer	AC2 / You
Test Mode	802.11b_TX_CH 6 ANT 0+1	Test Voltage	AC 120V/60Hz

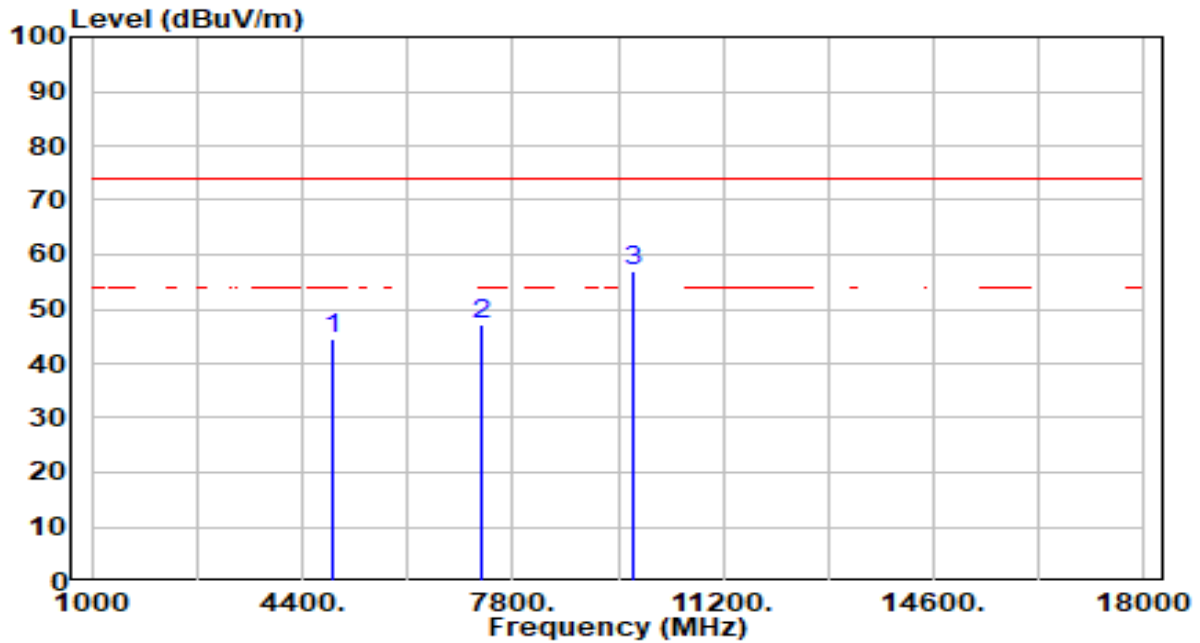

No	Frequency (MHz)	Reading (dBuV)	C.F (dB/m)	Measurement (dBuV/m)	Margin (dB)	Limit (dBuV/m)	Height (cm)	Angle (deg)	Remark (QP/PK/AV)
1	4874.000	44.19	0.36	44.55	-29.45	74.00	200	181	Peak
2	7311.000	41.62	5.59	47.21	-26.79	74.00	200	141	Peak
3	* 9748.000	51.58	5.34	56.92	-17.08	74.00	200	204	Peak

Note:

1. " \*", means this data is the worst emission level.
2. C.F (Correction Factor) = Antenna Factor (dB/m) + Cable Loss (dB) – Preamplifier(dB).
3. Measurement (dBuV/m) = Reading(dBuV) + C.F (Correction Factor).
4. The emission levels of other frequencies are very lower than the limit and not show in test report.

EUT	BE11000 Ceiling Mount Wi-Fi 7 Access Point	Date of Test	2024-05-27
Factor	DRH18-E	Temp. / Humidity	20°C /65%
Polarity	Horizontal	Site / Test Engineer	AC2 / You
Test Mode	802.11b_TX_CH 11 ANT 0+1	Test Voltage	AC 120V/60Hz

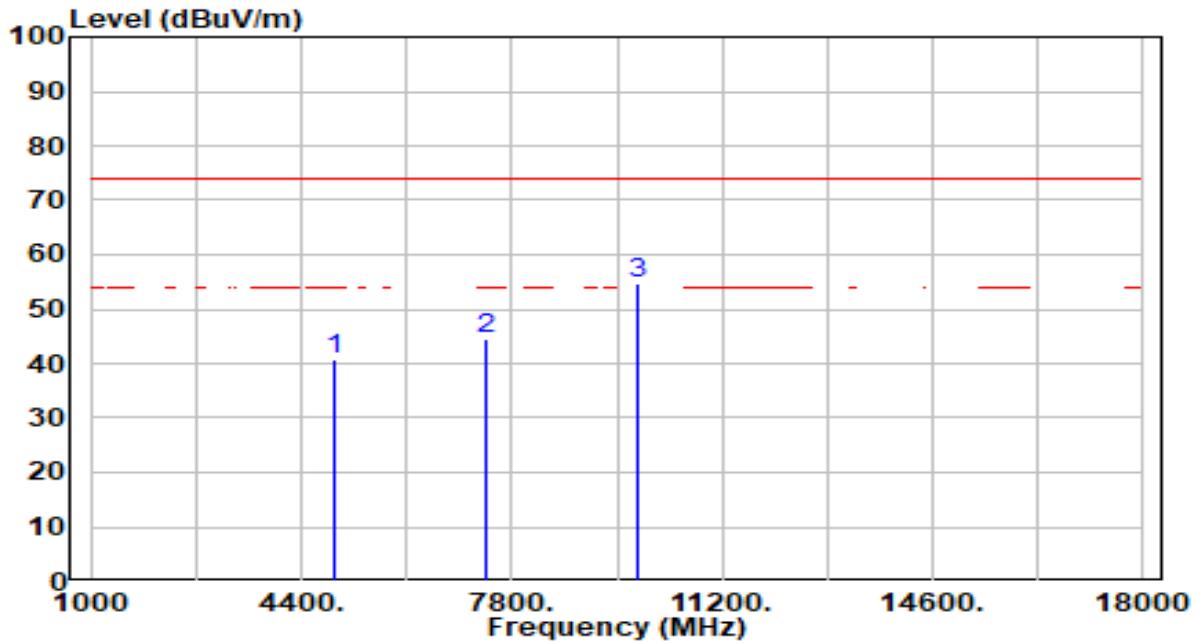

No	Frequency (MHz)	Reading (dBuV)	C.F (dB/m)	Measurement (dBuV/m)	Margin (dB)	Limit (dBuV/m)	Height (cm)	Angle (deg)	Remark (QP/PK/AV)
1	4924.000	40.25	0.49	40.75	-33.25	74.00	100	171	Peak
2	7386.000	38.72	5.64	44.36	-29.64	74.00	100	125	Peak
3	* 9848.000	49.21	5.39	54.59	-19.41	74.00	100	225	Peak

Note:

1. " \*", means this data is the worst emission level.
2. C.F (Correction Factor) = Antenna Factor (dB/m) + Cable Loss (dB) – Preamplifier(dB).
3. Measurement (dBuV/m) = Reading(dBuV) + C.F (Correction Factor).
4. The emission levels of other frequencies are very lower than the limit and not show in test report.



EUT	BE11000 Ceiling Mount Wi-Fi 7 Access Point	Date of Test	2024-05-27
Factor	DRH18-E	Temp. / Humidity	20°C /65%
Polarity	Vertical	Site / Test Engineer	AC2 / You
Test Mode	802.11b_TX_CH 11 ANT 0+1	Test Voltage	AC 120V/60Hz

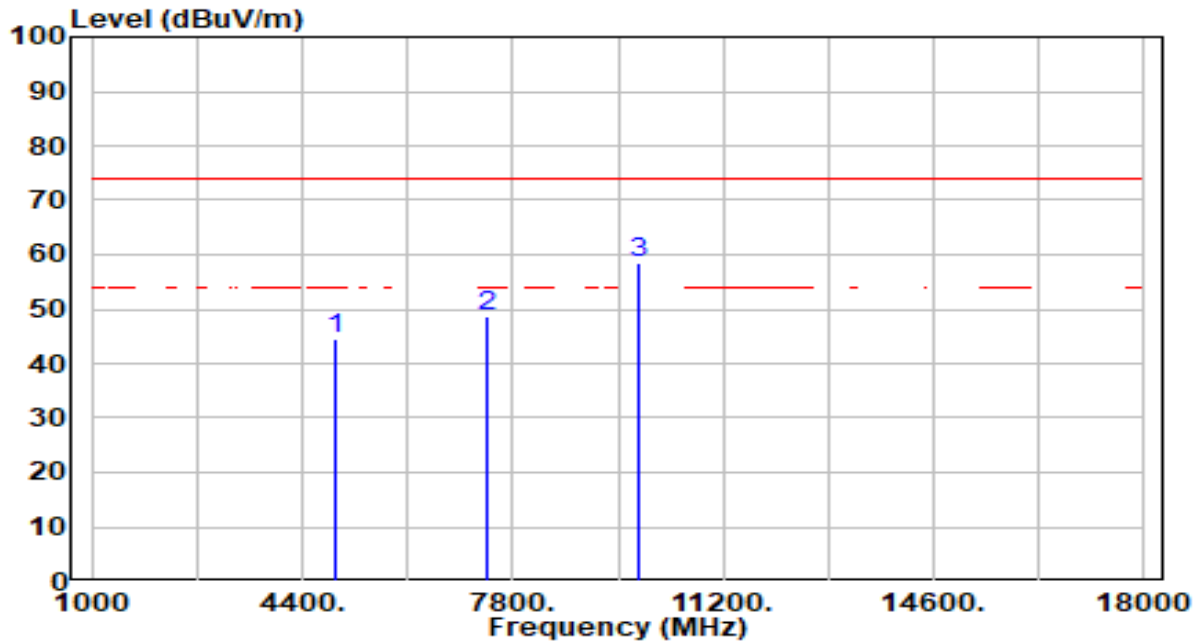

No	Frequency (MHz)	Reading (dBuV)	C.F (dB/m)	Measurement (dBuV/m)	Margin (dB)	Limit (dBuV/m)	Height (cm)	Angle (deg)	Remark (QP/PK/AV)
1	4924.000	43.85	0.49	44.34	-29.66	74.00	200	176	Peak
2	7386.000	43.10	5.64	48.74	-25.26	74.00	200	115	Peak
3	* 9848.000	53.13	5.39	58.52	-15.48	74.00	200	210	Peak

Note:

1. " \*", means this data is the worst emission level.
2. C.F (Correction Factor) = Antenna Factor (dB/m) + Cable Loss (dB) – Preamplifier(dB).
3. Measurement (dBuV/m) = Reading(dBuV) + C.F (Correction Factor).
4. The emission levels of other frequencies are very lower than the limit and not show in test report.

EUT	BE11000 Ceiling Mount Wi-Fi 7 Access Point	Date of Test	2024-05-27
Factor	DRH18-E	Temp. / Humidity	20°C /65%
Polarity	Horizontal	Site / Test Engineer	AC2 / You
Test Mode	802.11g_TX_CH 1 ANT 0+1	Test Voltage	AC 120V/60Hz

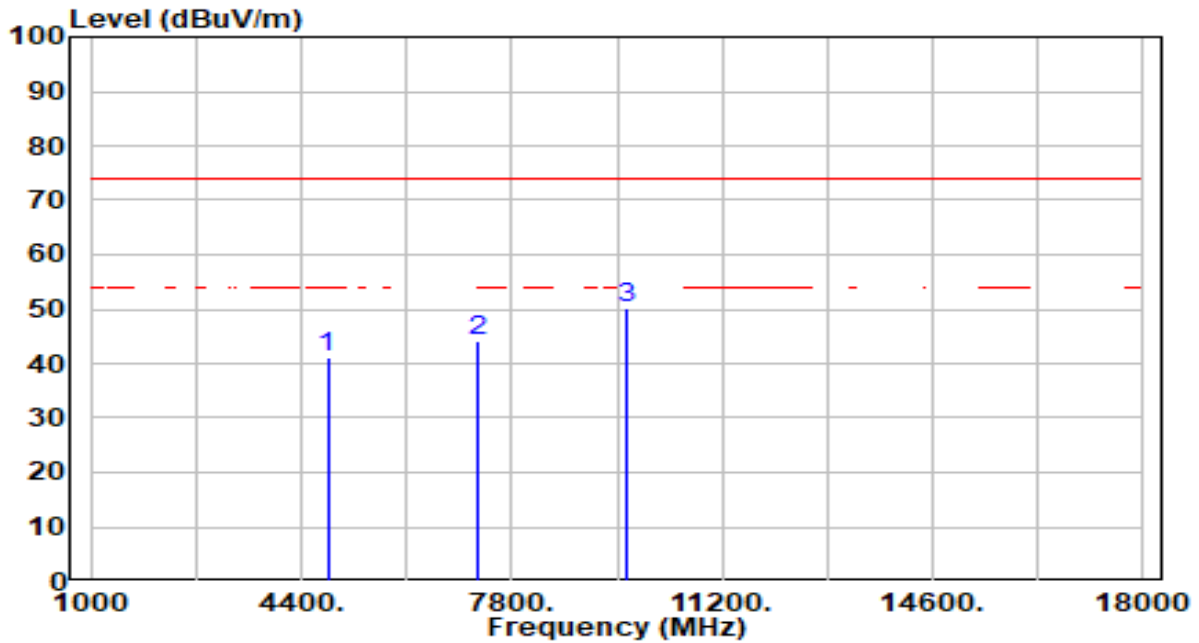

No	Frequency (MHz)	Reading (dBuV)	C.F (dB/m)	Measurement (dBuV/m)	Margin (dB)	Limit (dBuV/m)	Height (cm)	Angle (deg)	Remark (QP/PK/AV)
1	4824.000	40.87	0.23	41.11	-32.89	74.00	100	116	Peak
2	7236.000	38.63	5.54	44.18	-29.82	74.00	100	296	Peak
3	* 9648.000	44.87	5.30	50.17	-23.83	74.00	100	233	Peak

Note:

1. " \*", means this data is the worst emission level.
2. C.F (Correction Factor) = Antenna Factor (dB/m) + Cable Loss (dB) – Preamplifier(dB).
3. Measurement (dBuV/m) = Reading(dBuV) + C.F (Correction Factor).
4. The emission levels of other frequencies are very lower than the limit and not show in test report.

EUT	BE11000 Ceiling Mount Wi-Fi 7 Access Point	Date of Test	2024-05-27
Factor	DRH18-E	Temp. / Humidity	20°C /65%
Polarity	Vertical	Site / Test Engineer	AC2 / You
Test Mode	802.11g_TX_CH 1 ANT 0+1	Test Voltage	AC 120V/60Hz

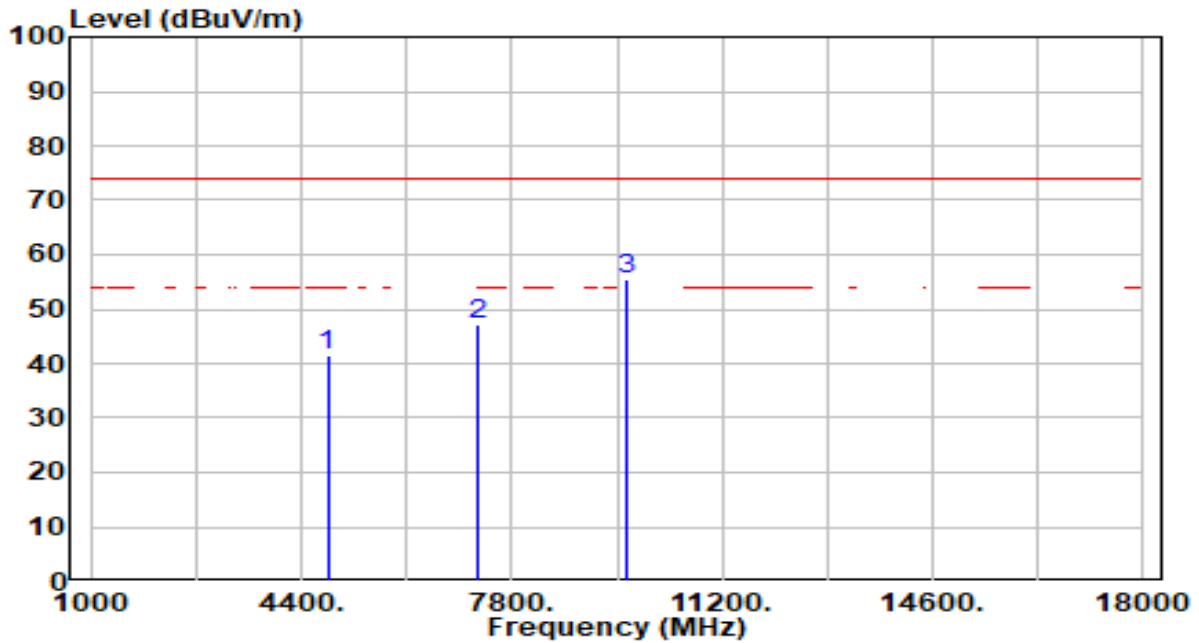

No	Frequency (MHz)	Reading (dBuV)	C.F (dB/m)	Measurement (dBuV/m)	Margin (dB)	Limit (dBuV/m)	Height (cm)	Angle (deg)	Remark (QP/PK/AV)
1	4824.000	41.18	0.23	41.41	-32.59	74.00	200	178	Peak
2	7236.000	41.45	5.54	47.00	-27.00	74.00	200	146	Peak
3	* 9648.000	50.10	5.30	55.40	-18.60	74.00	200	198	Peak

Note:

1. " \*", means this data is the worst emission level.
2. C.F (Correction Factor) = Antenna Factor (dB/m) + Cable Loss (dB) – Preamplifier(dB).
3. Measurement (dBuV/m) = Reading(dBuV) + C.F (Correction Factor).
4. The emission levels of other frequencies are very lower than the limit and not show in test report.

EUT	BE11000 Ceiling Mount Wi-Fi 7 Access Point	Date of Test	2024-05-27
Factor	DRH18-E	Temp. / Humidity	20°C /65%
Polarity	Horizontal	Site / Test Engineer	AC2 / You
Test Mode	802.11g_TX_CH 6 ANT 0+1	Test Voltage	AC 120V/60Hz

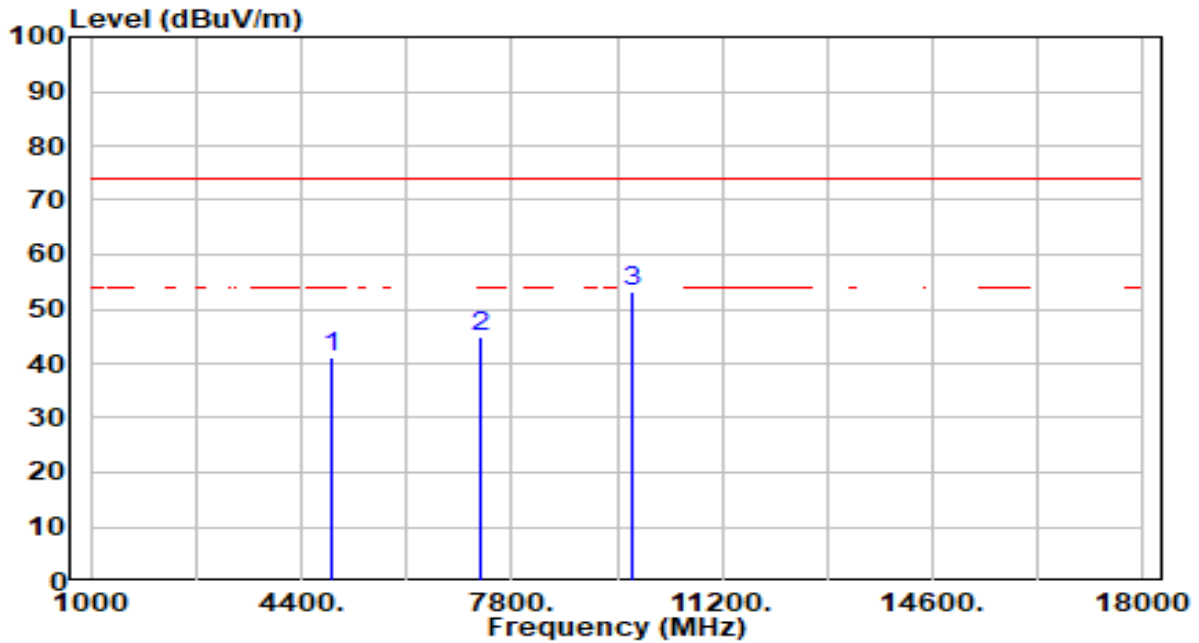

No	Frequency (MHz)	Reading (dBuV)	C.F (dB/m)	Measurement (dBuV/m)	Margin (dB)	Limit (dBuV/m)	Height (cm)	Angle (deg)	Remark (QP/PK/AV)
1	4874.000	40.84	0.36	41.21	-32.79	74.00	100	159	Peak
2	7311.000	39.37	5.59	44.96	-29.04	74.00	100	128	Peak
3	* 9748.000	47.93	5.34	53.27	-20.73	74.00	100	165	Peak

Note:

1. " \*", means this data is the worst emission level.
2. C.F (Correction Factor) = Antenna Factor (dB/m) + Cable Loss (dB) – Preamplifier(dB).
3. Measurement (dBuV/m) = Reading(dBuV) + C.F (Correction Factor).
4. The emission levels of other frequencies are very lower than the limit and not show in test report.

EUT	BE11000 Ceiling Mount Wi-Fi 7 Access Point	Date of Test	2024-05-27
Factor	DRH18-E	Temp. / Humidity	20°C /65%
Polarity	Vertical	Site / Test Engineer	AC2 / You
Test Mode	802.11g_TX_CH 6 ANT 0+1	Test Voltage	AC 120V/60Hz

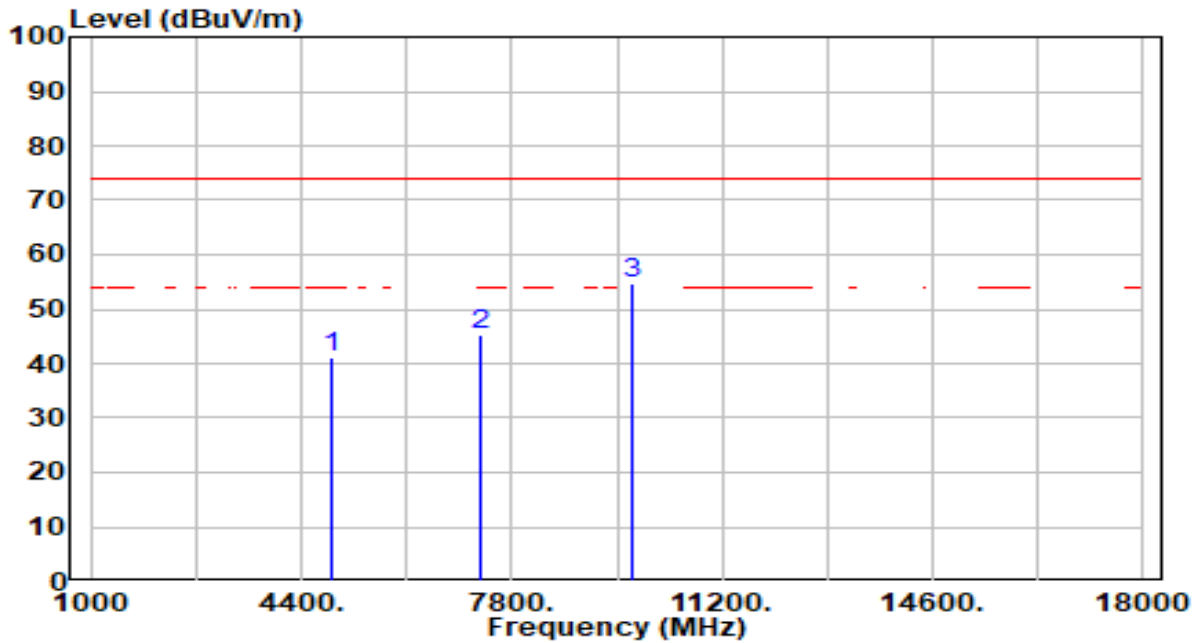

No	Frequency (MHz)	Reading (dBuV)	C.F (dB/m)	Measurement (dBuV/m)	Margin (dB)	Limit (dBuV/m)	Height (cm)	Angle (deg)	Remark (QP/PK/AV)
1	4874.000	40.77	0.36	41.14	-32.86	74.00	200	226	Peak
2	7311.000	39.88	5.59	45.47	-28.53	74.00	200	129	Peak
3	* 9748.000	49.30	5.34	54.65	-19.35	74.00	200	223	Peak

Note:

1. " \*", means this data is the worst emission level.
2. C.F (Correction Factor) = Antenna Factor (dB/m) + Cable Loss (dB) – Preamplifier(dB).
3. Measurement (dBuV/m) = Reading(dBuV) + C.F (Correction Factor).
4. The emission levels of other frequencies are very lower than the limit and not show in test report.

EUT	BE11000 Ceiling Mount Wi-Fi 7 Access Point	Date of Test	2024-05-27
Factor	DRH18-E	Temp. / Humidity	20°C /65%
Polarity	Horizontal	Site / Test Engineer	AC2 / You
Test Mode	802.11g_TX_CH 11 ANT 0+1	Test Voltage	AC 120V/60Hz

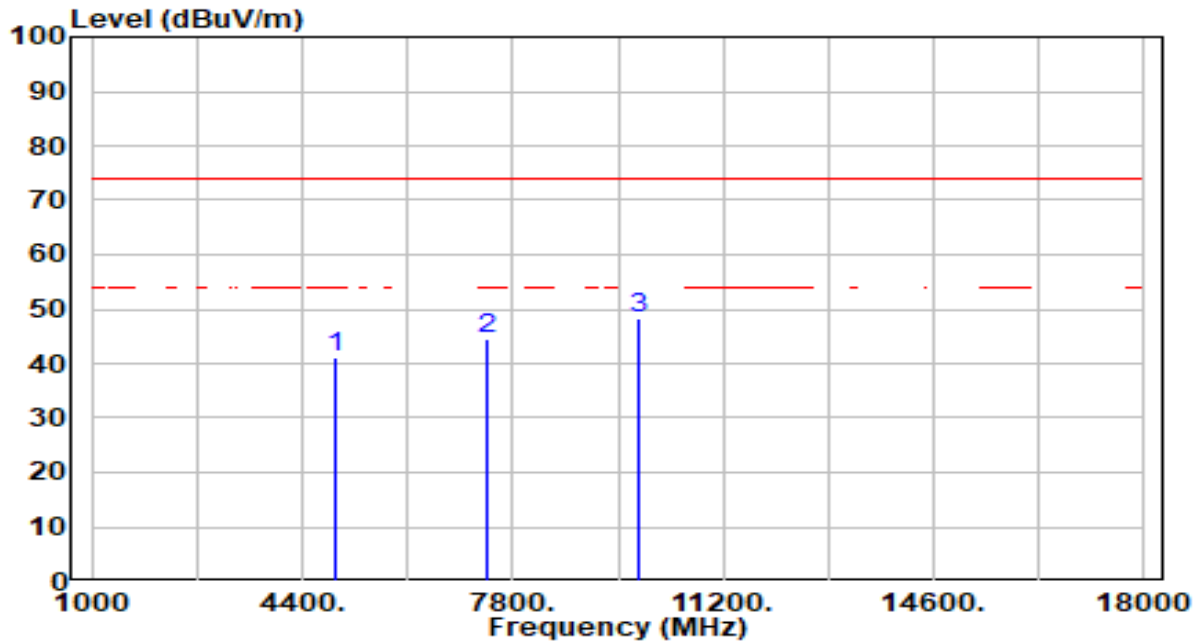

No	Frequency (MHz)	Reading (dBuV)	C.F (dB/m)	Measurement (dBuV/m)	Margin (dB)	Limit (dBuV/m)	Height (cm)	Angle (deg)	Remark (QP/PK/AV)
1	4924.000	40.54	0.49	41.03	-32.97	74.00	100	335	Peak
2	7386.000	39.02	5.64	44.65	-29.35	74.00	100	75	Peak
3	* 9848.000	42.93	5.39	48.31	-25.69	74.00	100	233	Peak

Note:

1. " \*", means this data is the worst emission level.
2. C.F (Correction Factor) = Antenna Factor (dB/m) + Cable Loss (dB) – Preamplifier(dB).
3. Measurement (dBuV/m) = Reading(dBuV) + C.F (Correction Factor).
4. The emission levels of other frequencies are very lower than the limit and not show in test report.

EUT	BE11000 Ceiling Mount Wi-Fi 7 Access Point	Date of Test	2024-05-27
Factor	DRH18-E	Temp. / Humidity	20°C /65%
Polarity	Vertical	Site / Test Engineer	AC2 / You
Test Mode	802.11g_TX_CH 11 ANT 0+1	Test Voltage	AC 120V/60Hz

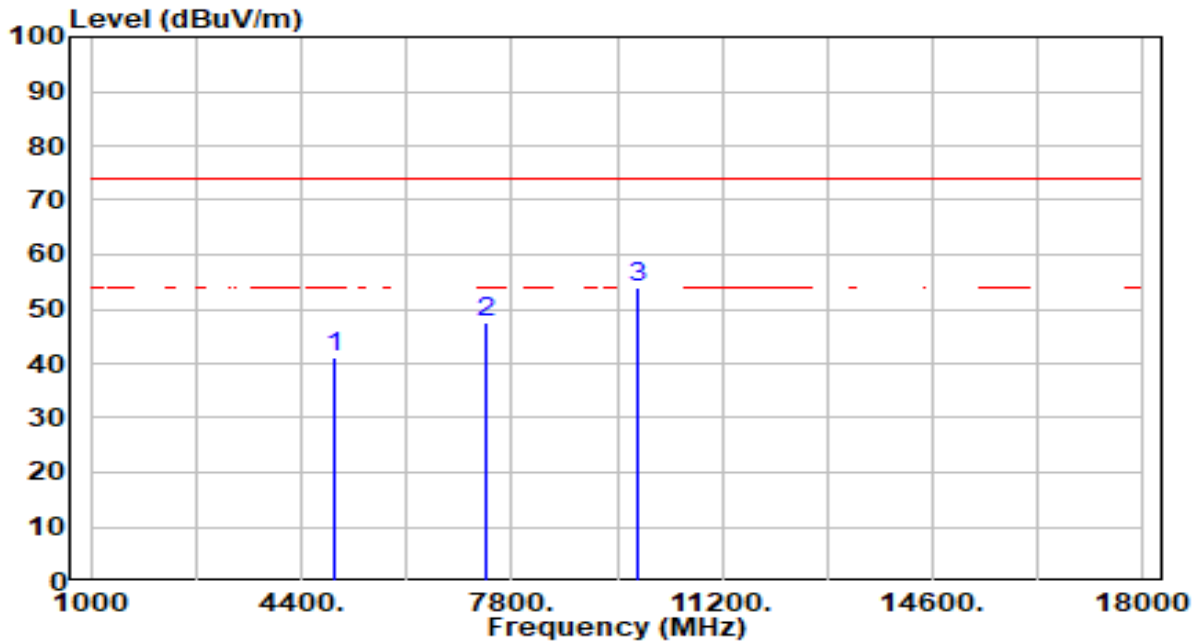

No	Frequency (MHz)	Reading (dBuV)	C.F (dB/m)	Measurement (dBuV/m)	Margin (dB)	Limit (dBuV/m)	Height (cm)	Angle (deg)	Remark (QP/PK/AV)
1	4924.000	40.69	0.49	41.18	-32.82	74.00	200	152	Peak
2	7386.000	41.94	5.64	47.58	-26.42	74.00	200	120	Peak
3	* 9848.000	48.69	5.39	54.08	-19.92	74.00	200	194	Peak

Note:

1. " \*", means this data is the worst emission level.
2. C.F (Correction Factor) = Antenna Factor (dB/m) + Cable Loss (dB) – Preamplifier(dB).
3. Measurement (dBuV/m) = Reading(dBuV) + C.F (Correction Factor).
4. The emission levels of other frequencies are very lower than the limit and not show in test report.

EUT	BE11000 Ceiling Mount Wi-Fi 7 Access Point	Date of Test	2024-05-27
Factor	DRH18-E	Temp. / Humidity	20°C /65%
Polarity	Horizontal	Site / Test Engineer	AC2 / You
Test Mode	802.11n-20MHz_TX_CH 1 ANT 0+1	Test Voltage	AC 120V/60Hz

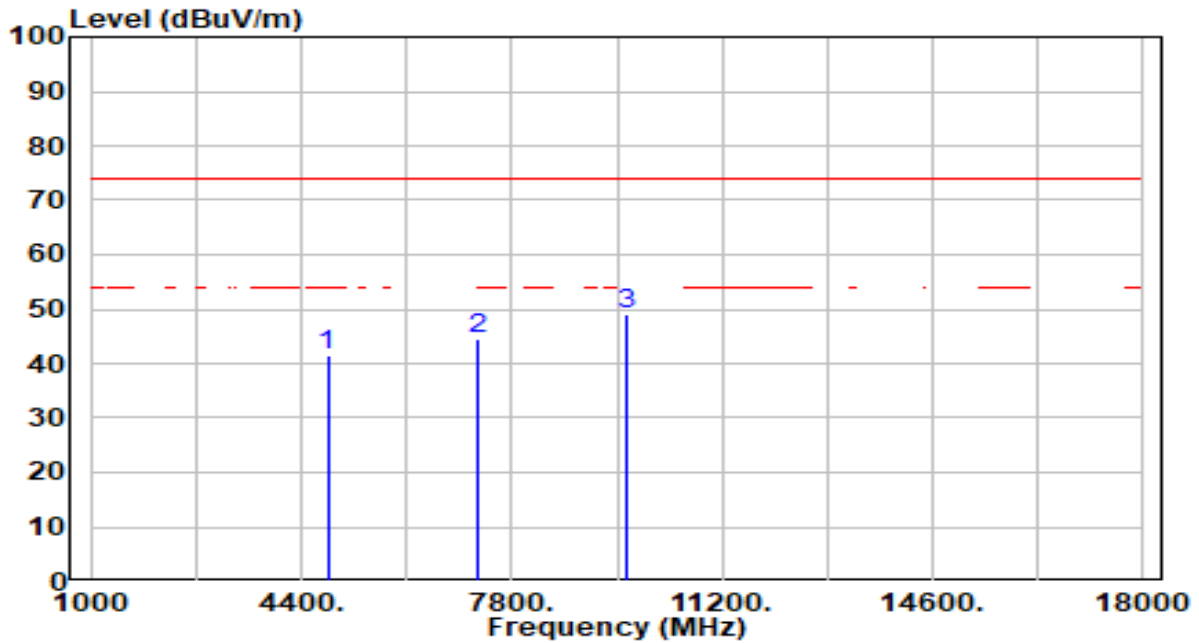

No	Frequency (MHz)	Reading (dBuV)	C.F (dB/m)	Measurement (dBuV/m)	Margin (dB)	Limit (dBuV/m)	Height (cm)	Angle (deg)	Remark (QP/PK/AV)
1	4824.000	41.31	0.23	41.54	-32.46	74.00	100	160	Peak
2	7236.000	38.81	5.54	44.35	-29.65	74.00	100	178	Peak
3	* 9648.000	43.82	5.30	49.12	-24.88	74.00	100	229	Peak

Note:

1. " \*", means this data is the worst emission level.
2. C.F (Correction Factor) = Antenna Factor (dB/m) + Cable Loss (dB) – Preamplifier(dB).
3. Measurement (dBuV/m) = Reading(dBuV) + C.F (Correction Factor).
4. The emission levels of other frequencies are very lower than the limit and not show in test report.



EUT	BE11000 Ceiling Mount Wi-Fi 7 Access Point	Date of Test	2024-05-27
Factor	DRH18-E	Temp. / Humidity	20°C /65%
Polarity	Vertical	Site / Test Engineer	AC2 / You
Test Mode	802.11n-20MHz_TX_CH 1 ANT 0+1	Test Voltage	AC 120V/60Hz

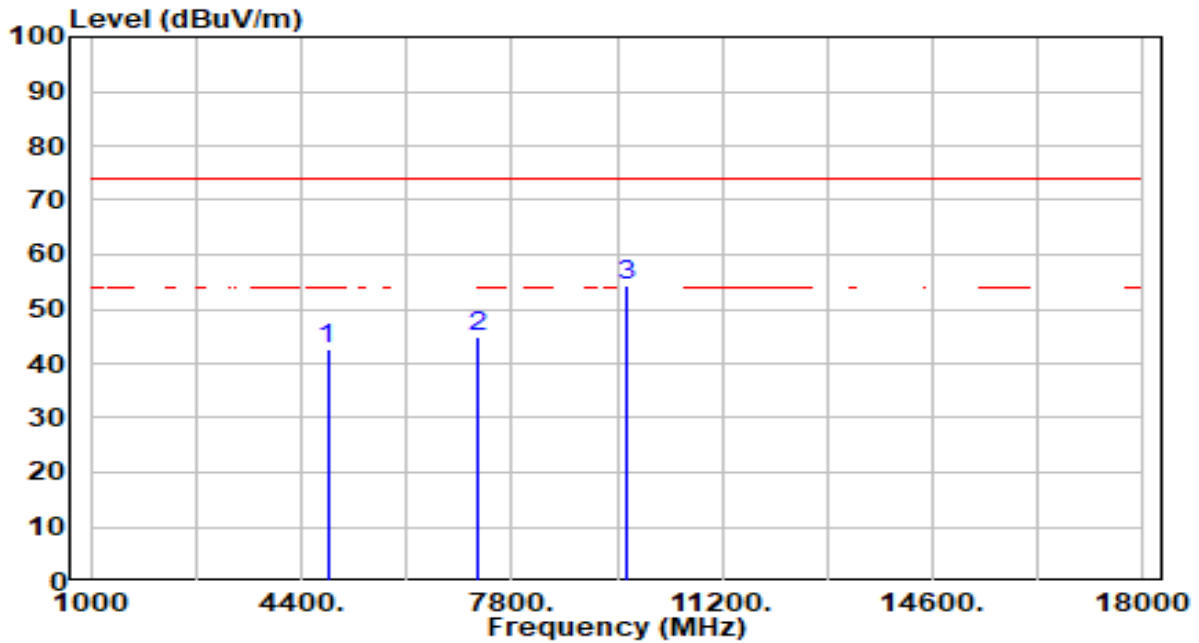

No	Frequency (MHz)	Reading (dBuV)	C.F (dB/m)	Measurement (dBuV/m)	Margin (dB)	Limit (dBuV/m)	Height (cm)	Angle (deg)	Remark (QP/PK/AV)
1	4824.000	42.33	0.23	42.56	-31.44	74.00	200	180	Peak
2	7236.000	39.23	5.54	44.77	-29.23	74.00	200	134	Peak
3	* 9648.000	48.99	5.30	54.29	-19.71	74.00	200	240	Peak

Note:

1. " \*", means this data is the worst emission level.
2. C.F (Correction Factor) = Antenna Factor (dB/m) + Cable Loss (dB) – Preamplifier(dB).
3. Measurement (dBuV/m) = Reading(dBuV) + C.F (Correction Factor).
4. The emission levels of other frequencies are very lower than the limit and not show in test report.

EUT	BE11000 Ceiling Mount Wi-Fi 7 Access Point	Date of Test	2024-05-27
Factor	DRH18-E	Temp. / Humidity	20°C /65%
Polarity	Horizontal	Site / Test Engineer	AC2 / You
Test Mode	802.11n-20MHz_TX_CH 6 ANT 0+1	Test Voltage	AC 120V/60Hz

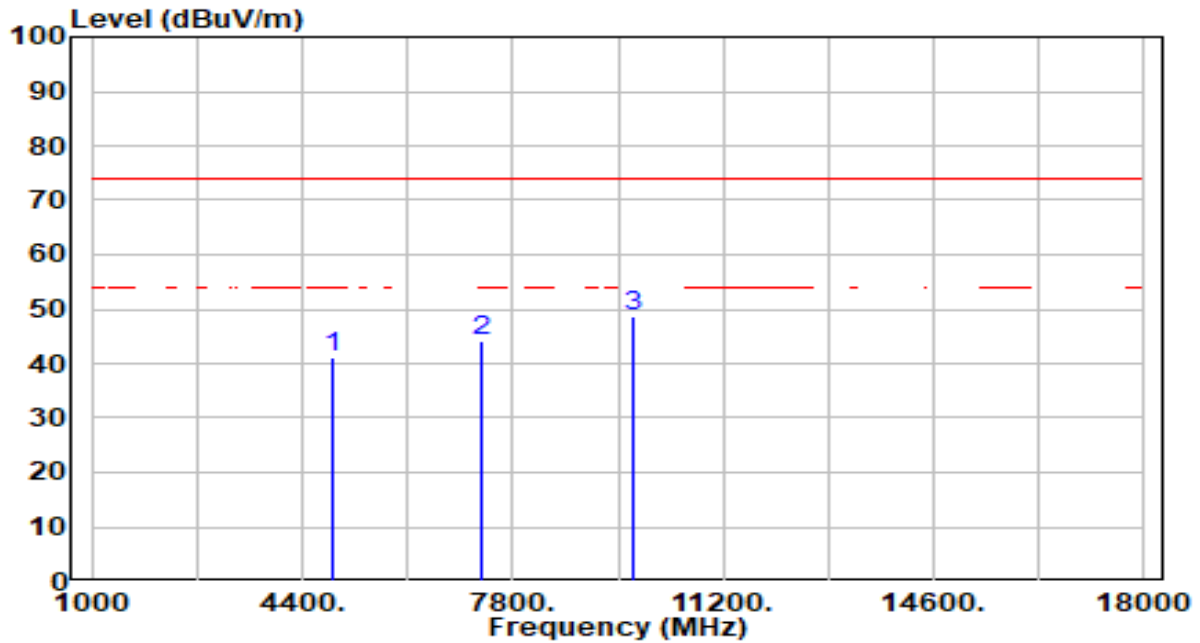

No	Frequency (MHz)	Reading (dBuV)	C.F (dB/m)	Measurement (dBuV/m)	Margin (dB)	Limit (dBuV/m)	Height (cm)	Angle (deg)	Remark (QP/PK/AV)
1	4874.000	40.73	0.36	41.10	-32.90	74.00	100	276	Peak
2	7311.000	38.45	5.59	44.04	-29.96	74.00	100	188	Peak
3	* 9748.000	43.28	5.34	48.63	-25.37	74.00	100	113	Peak

Note:

1. " \*", means this data is the worst emission level.
2. C.F (Correction Factor) = Antenna Factor (dB/m) + Cable Loss (dB) – Preamplifier(dB).
3. Measurement (dBuV/m) = Reading(dBuV) + C.F (Correction Factor).
4. The emission levels of other frequencies are very lower than the limit and not show in test report.

EUT	BE11000 Ceiling Mount Wi-Fi 7 Access Point	Date of Test	2024-05-27
Factor	DRH18-E	Temp. / Humidity	20°C /65%
Polarity	Vertical	Site / Test Engineer	AC2 / You
Test Mode	802.11n-20MHz_TX_CH 6 ANT 0+1	Test Voltage	AC 120V/60Hz

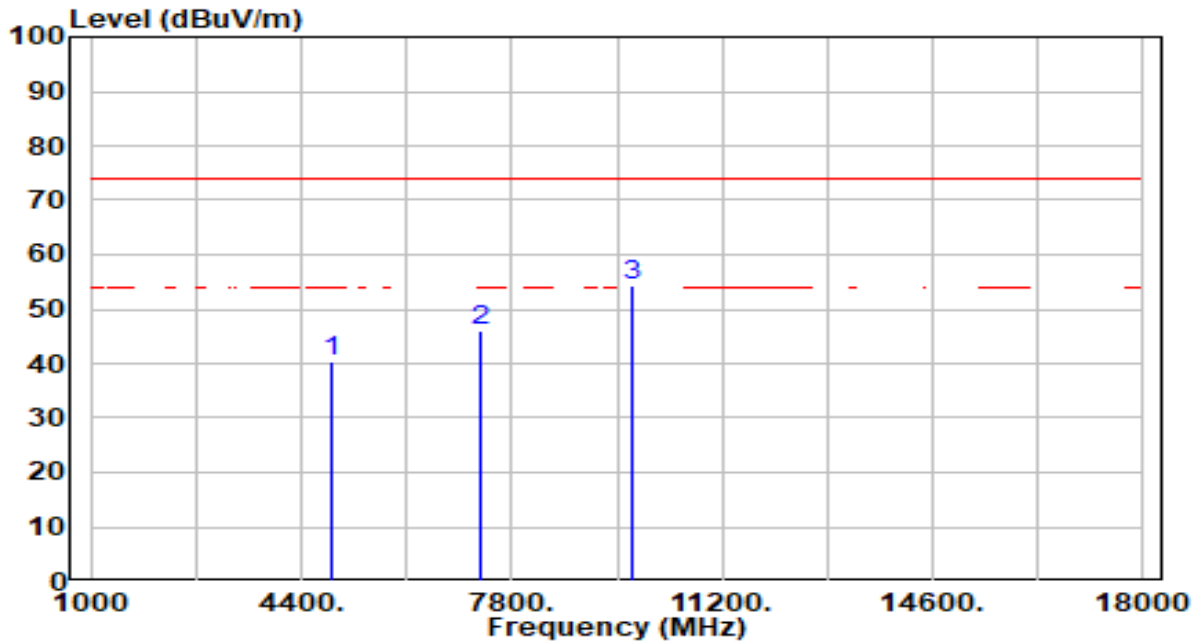

No	Frequency (MHz)	Reading (dBuV)	C.F (dB/m)	Measurement (dBuV/m)	Margin (dB)	Limit (dBuV/m)	Height (cm)	Angle (deg)	Remark (QP/PK/AV)
1	4874.000	40.01	0.36	40.37	-33.63	74.00	200	317	Peak
2	7311.000	40.60	5.59	46.19	-27.81	74.00	200	140	Peak
3	* 9748.000	48.83	5.34	54.17	-19.83	74.00	200	197	Peak

Note:

1. " \*", means this data is the worst emission level.
2. C.F (Correction Factor) = Antenna Factor (dB/m) + Cable Loss (dB) – Preamplifier(dB).
3. Measurement (dBuV/m) = Reading(dBuV) + C.F (Correction Factor).
4. The emission levels of other frequencies are very lower than the limit and not show in test report.

EUT	BE11000 Ceiling Mount Wi-Fi 7 Access Point	Date of Test	2024-05-27
Factor	DRH18-E	Temp. / Humidity	20°C /65%
Polarity	Horizontal	Site / Test Engineer	AC2 / You
Test Mode	802.11n-20MHz_TX_CH 11 ANT 0+1	Test Voltage	AC 120V/60Hz

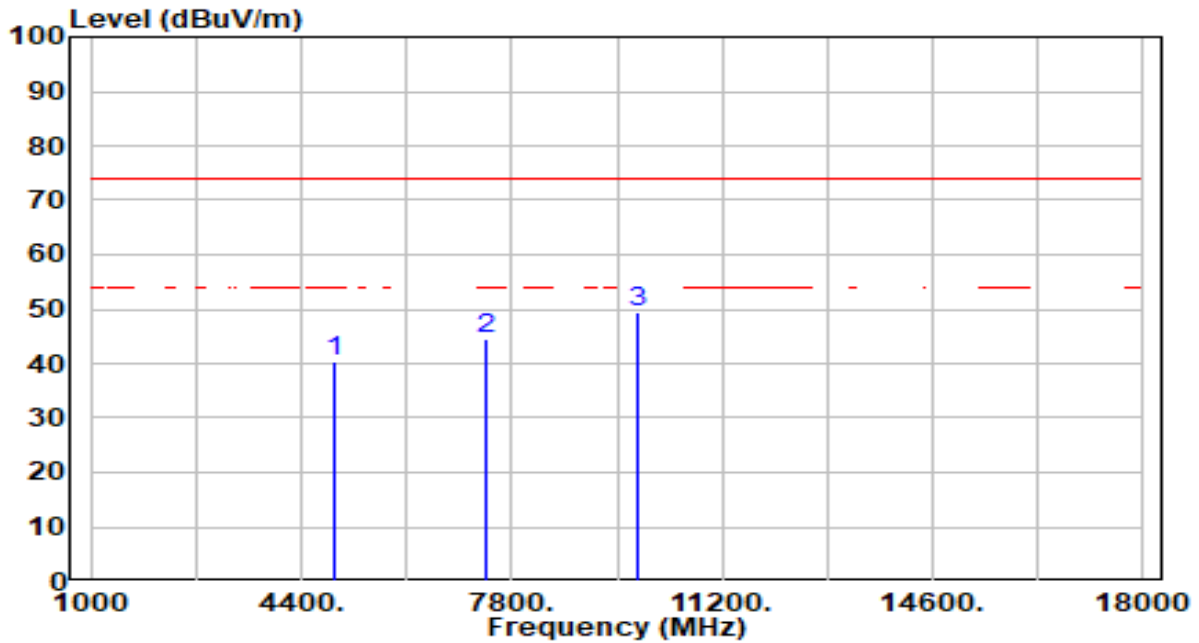

No	Frequency (MHz)	Reading (dBuV)	C.F (dB/m)	Measurement (dBuV/m)	Margin (dB)	Limit (dBuV/m)	Height (cm)	Angle (deg)	Remark (QP/PK/AV)
1	4924.000	39.72	0.49	40.21	-33.79	74.00	100	296	Peak
2	7386.000	38.75	5.64	44.39	-29.61	74.00	100	53	Peak
3	* 9848.000	44.14	5.39	49.53	-24.47	74.00	100	121	Peak

Note:

1. " \*", means this data is the worst emission level.
2. C.F (Correction Factor) = Antenna Factor (dB/m) + Cable Loss (dB) – Preamplifier(dB).
3. Measurement (dBuV/m) = Reading(dBuV) + C.F (Correction Factor).
4. The emission levels of other frequencies are very lower than the limit and not show in test report.

EUT	BE11000 Ceiling Mount Wi-Fi 7 Access Point	Date of Test	2024-05-27
Factor	DRH18-E	Temp. / Humidity	20°C /65%
Polarity	Vertical	Site / Test Engineer	AC2 / You
Test Mode	802.11n-20MHz_TX_CH 11 ANT 0+1	Test Voltage	AC 120V/60Hz

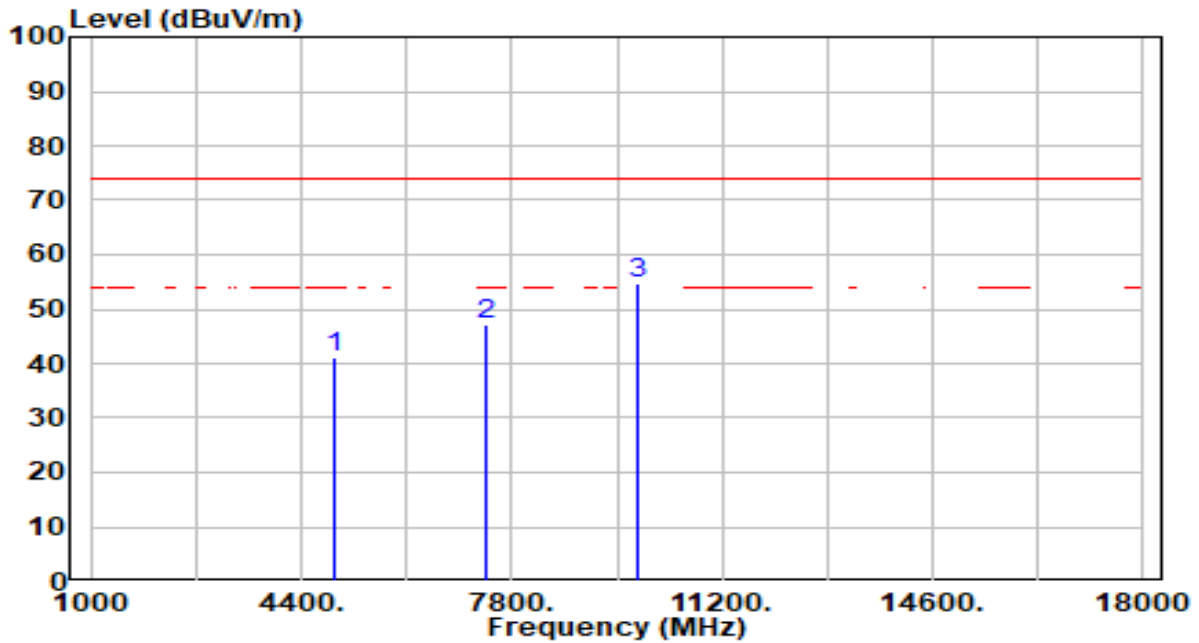

No	Frequency (MHz)	Reading (dBuV)	C.F (dB/m)	Measurement (dBuV/m)	Margin (dB)	Limit (dBuV/m)	Height (cm)	Angle (deg)	Remark (QP/PK/AV)
1	4924.000	40.77	0.49	41.26	-32.74	74.00	200	215	Peak
2	7386.000	41.36	5.64	46.99	-27.01	74.00	200	149	Peak
3	* 9848.000	49.28	5.39	54.66	-19.34	74.00	200	206	Peak

Note:

1. " \*", means this data is the worst emission level.
2. C.F (Correction Factor) = Antenna Factor (dB/m) + Cable Loss (dB) – Preamplifier(dB).
3. Measurement (dBuV/m) = Reading(dBuV) + C.F (Correction Factor).
4. The emission levels of other frequencies are very lower than the limit and not show in test report.

EUT	BE11000 Ceiling Mount Wi-Fi 7 Access Point	Date of Test	2024-05-27
Factor	DRH18-E	Temp. / Humidity	20°C /65%
Polarity	Horizontal	Site / Test Engineer	AC2 / You
Test Mode	802.11n-40MHz_TX_CH 3 ANT 0+1	Test Voltage	AC 120V/60Hz

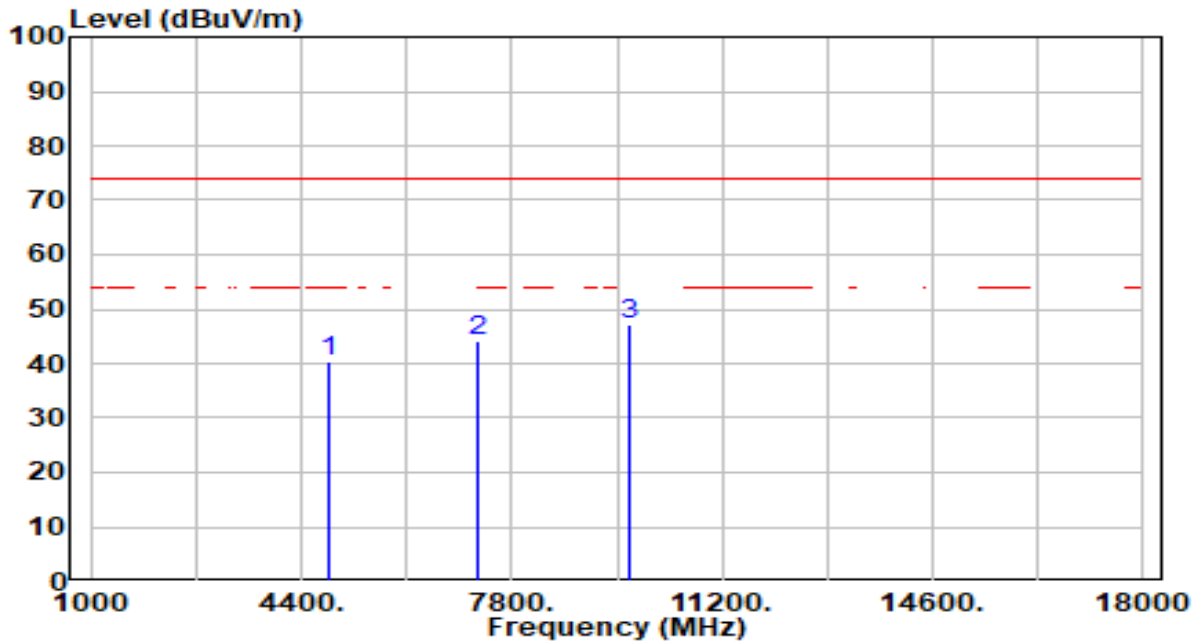

No	Frequency (MHz)	Reading (dBuV)	C.F (dB/m)	Measurement (dBuV/m)	Margin (dB)	Limit (dBuV/m)	Height (cm)	Angle (deg)	Remark (QP/PK/AV)
1	4844.000	40.19	0.28	40.48	-33.52	74.00	100	264	Peak
2	7266.000	38.59	5.56	44.15	-29.85	74.00	100	181	Peak
3	* 9688.000	41.68	5.32	47.00	-27.00	74.00	100	347	Peak

Note:

1. " \*", means this data is the worst emission level.
2. C.F (Correction Factor) = Antenna Factor (dB/m) + Cable Loss (dB) – Preamplifier(dB).
3. Measurement (dBuV/m) = Reading(dBuV) + C.F (Correction Factor).
4. The emission levels of other frequencies are very lower than the limit and not show in test report.

EUT	BE11000 Ceiling Mount Wi-Fi 7 Access Point	Date of Test	2024-05-27
Factor	DRH18-E	Temp. / Humidity	20°C /65%
Polarity	Vertical	Site / Test Engineer	AC2 / You
Test Mode	802.11n-40MHz_TX_CH 3 ANT 0+1	Test Voltage	AC 120V/60Hz

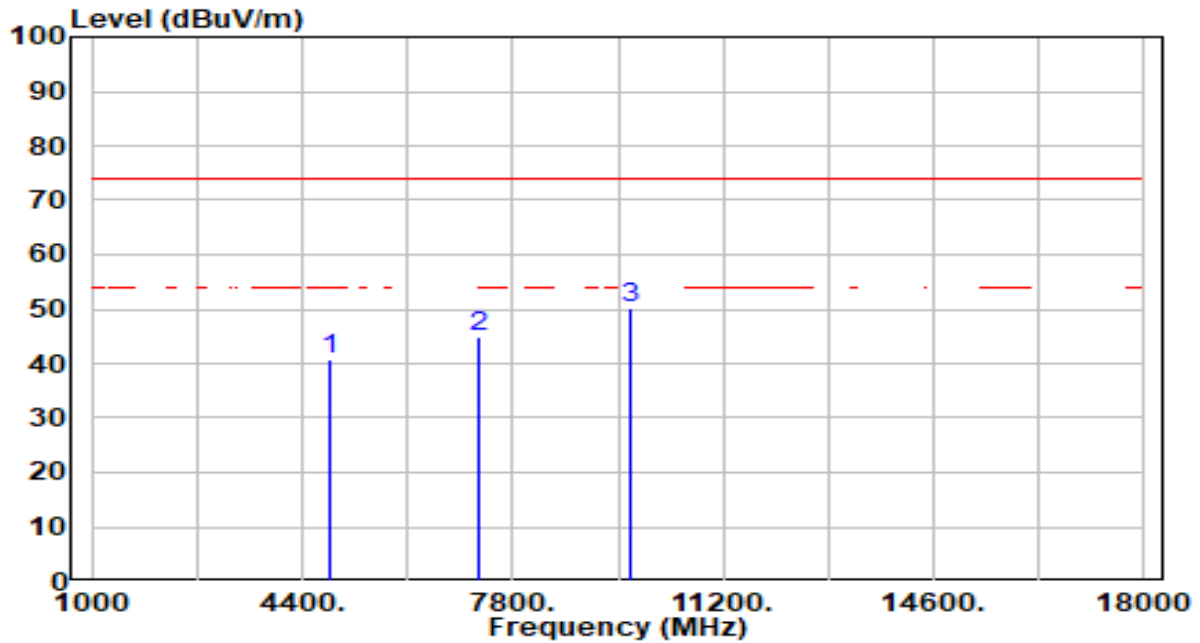

No	Frequency (MHz)	Reading (dBuV)	C.F (dB/m)	Measurement (dBuV/m)	Margin (dB)	Limit (dBuV/m)	Height (cm)	Angle (deg)	Remark (QP/PK/AV)
1	4844.000	40.42	0.28	40.70	-33.30	74.00	200	329	Peak
2	7266.000	39.22	5.56	44.78	-29.22	74.00	200	26	Peak
3	* 9688.000	44.93	5.32	50.25	-23.75	74.00	200	183	Peak

Note:

1. " \*", means this data is the worst emission level.
2. C.F (Correction Factor) = Antenna Factor (dB/m) + Cable Loss (dB) – Preamplifier(dB).
3. Measurement (dBuV/m) = Reading(dBuV) + C.F (Correction Factor).
4. The emission levels of other frequencies are very lower than the limit and not show in test report.

EUT	BE11000 Ceiling Mount Wi-Fi 7 Access Point	Date of Test	2024-05-27
Factor	DRH18-E	Temp. / Humidity	20°C /65%
Polarity	Horizontal	Site / Test Engineer	AC2 / You
Test Mode	802.11n-40MHz_TX_CH 6 ANT 0+1	Test Voltage	AC 120V/60Hz

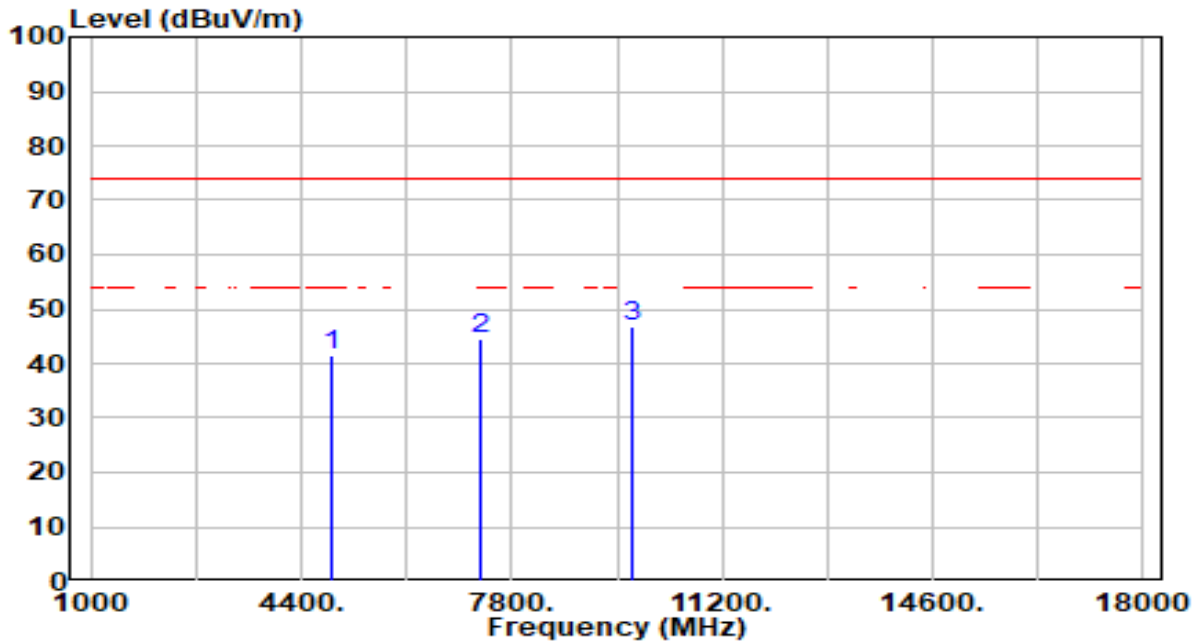

No	Frequency (MHz)	Reading (dBuV)	C.F (dB/m)	Measurement (dBuV/m)	Margin (dB)	Limit (dBuV/m)	Height (cm)	Angle (deg)	Remark (QP/PK/AV)
1	4874.000	41.29	0.36	41.66	-32.34	74.00	100	284	Peak
2	7311.000	38.97	5.59	44.56	-29.44	74.00	100	54	Peak
3	* 9748.000	41.49	5.34	46.83	-27.17	74.00	100	330	Peak

Note:

1. " \*", means this data is the worst emission level.
2. C.F (Correction Factor) = Antenna Factor (dB/m) + Cable Loss (dB) – Preamplifier(dB).
3. Measurement (dBuV/m) = Reading(dBuV) + C.F (Correction Factor).
4. The emission levels of other frequencies are very lower than the limit and not show in test report.



EUT	BE11000 Ceiling Mount Wi-Fi 7 Access Point	Date of Test	2024-05-27
Factor	DRH18-E	Temp. / Humidity	20°C /65%
Polarity	Vertical	Site / Test Engineer	AC2 / You
Test Mode	802.11n-40MHz_TX_CH 6 ANT 0+1	Test Voltage	AC 120V/60Hz

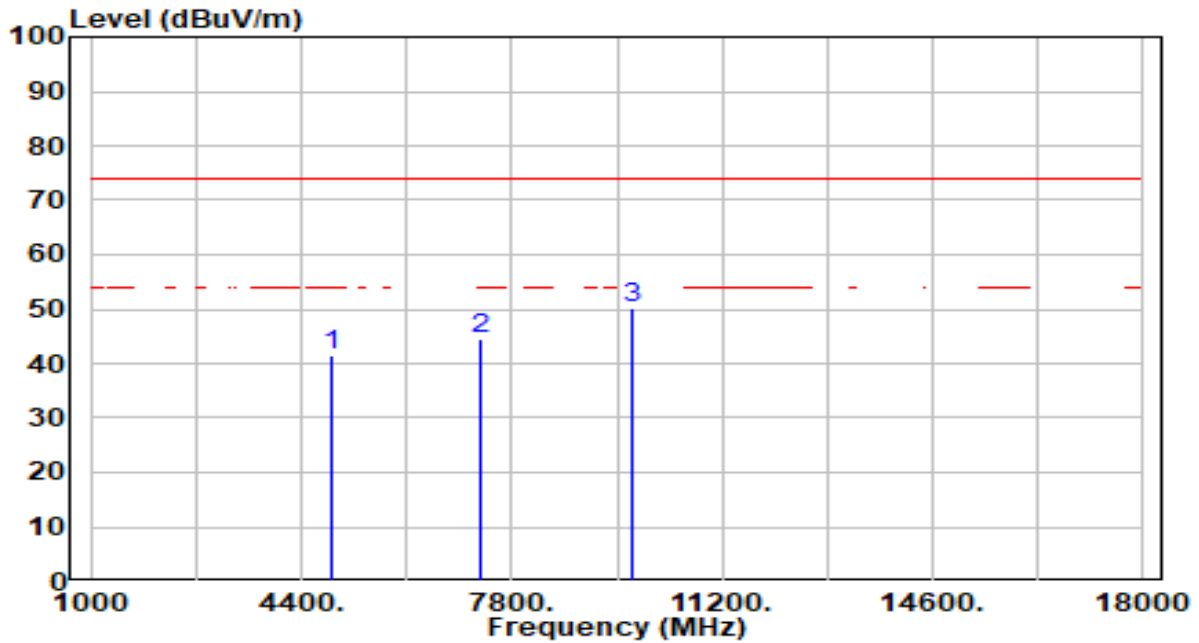

No	Frequency (MHz)	Reading (dBuV)	C.F (dB/m)	Measurement (dBuV/m)	Margin (dB)	Limit (dBuV/m)	Height (cm)	Angle (deg)	Remark (QP/PK/AV)
1	4874.000	40.96	0.36	41.33	-32.67	74.00	200	15	Peak
2	7311.000	39.03	5.59	44.62	-29.38	74.00	200	125	Peak
3	* 9748.000	44.78	5.34	50.12	-23.88	74.00	200	216	Peak

Note:

1. " \*", means this data is the worst emission level.
2. C.F (Correction Factor) = Antenna Factor (dB/m) + Cable Loss (dB) – Preamplifier(dB).
3. Measurement (dBuV/m) = Reading(dBuV) + C.F (Correction Factor).
4. The emission levels of other frequencies are very lower than the limit and not show in test report.

EUT	BE11000 Ceiling Mount Wi-Fi 7 Access Point	Date of Test	2024-05-27
Factor	DRH18-E	Temp. / Humidity	20°C /65%
Polarity	Horizontal	Site / Test Engineer	AC2 / You
Test Mode	802.11n-40MHz_TX_CH 9 ANT 0+1	Test Voltage	AC 120V/60Hz

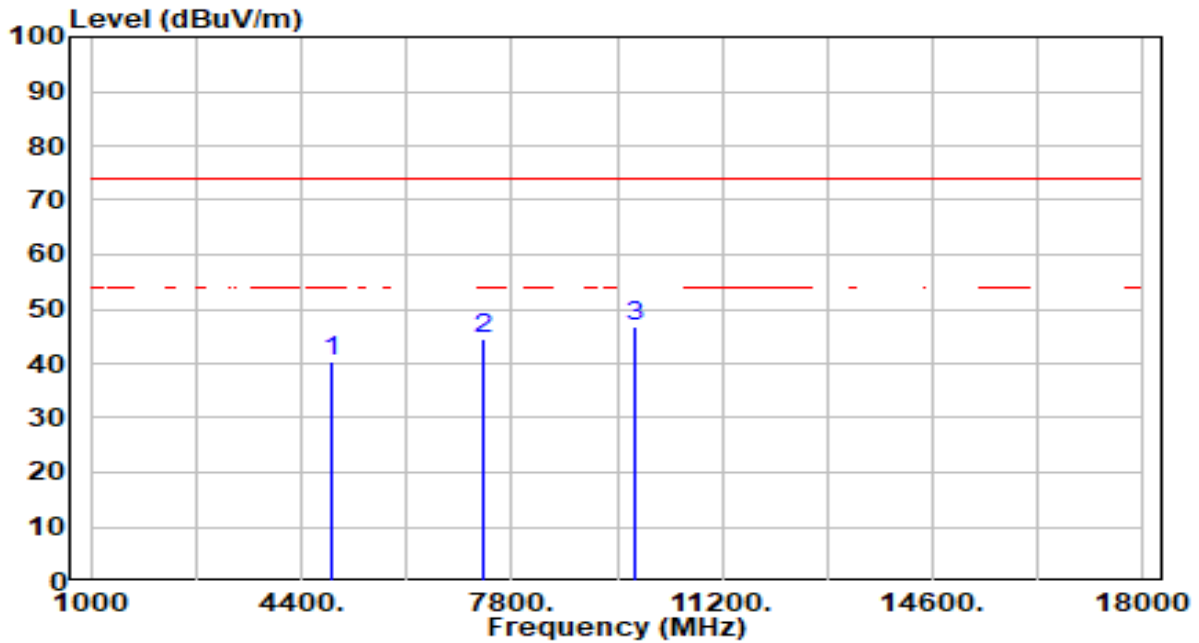

No	Frequency (MHz)	Reading (dBuV)	C.F (dB/m)	Measurement (dBuV/m)	Margin (dB)	Limit (dBuV/m)	Height (cm)	Angle (deg)	Remark (QP/PK/AV)
1	4904.000	39.78	0.44	40.22	-33.78	74.00	100	8	Peak
2	7356.000	38.87	5.62	44.49	-29.51	74.00	100	175	Peak
3	* 9808.000	41.55	5.37	46.92	-27.08	74.00	100	120	Peak

Note:

1. " \*", means this data is the worst emission level.
2. C.F (Correction Factor) = Antenna Factor (dB/m) + Cable Loss (dB) – Preamplifier(dB).
3. Measurement (dBuV/m) = Reading(dBuV) + C.F (Correction Factor).
4. The emission levels of other frequencies are very lower than the limit and not show in test report.

EUT	BE11000 Ceiling Mount Wi-Fi 7 Access Point	Date of Test	2024-05-27
Factor	DRH18-E	Temp. / Humidity	20°C /65%
Polarity	Vertical	Site / Test Engineer	AC2 / You
Test Mode	802.11n-40MHz_TX_CH 9 ANT 0+1	Test Voltage	AC 120V/60Hz

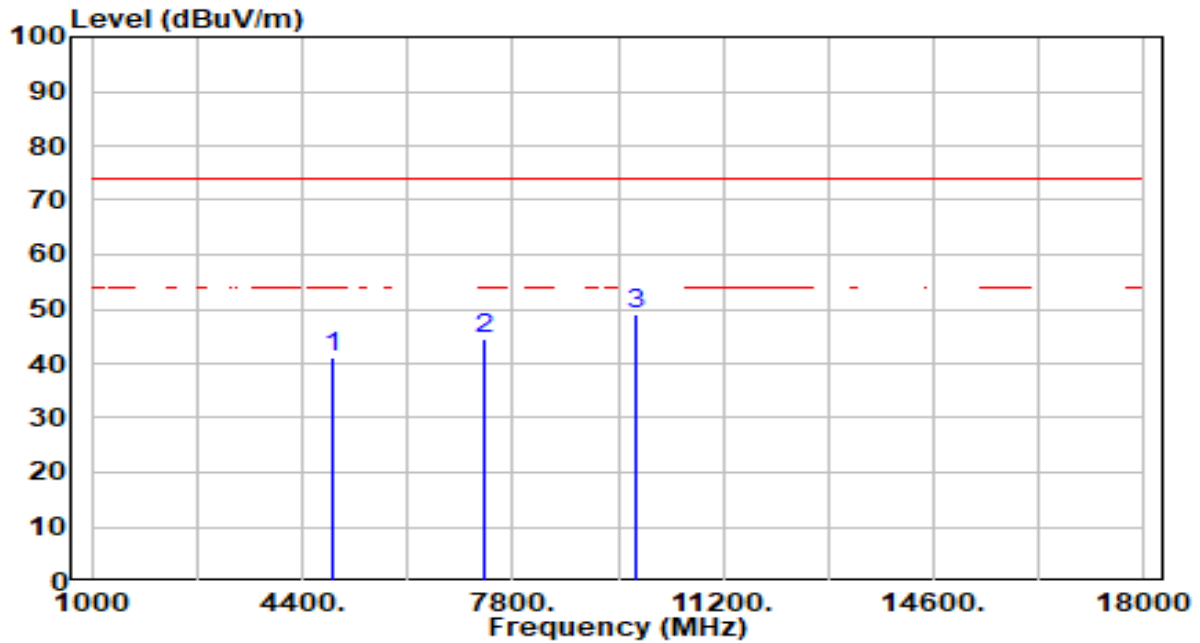

No	Frequency (MHz)	Reading (dBuV)	C.F (dB/m)	Measurement (dBuV/m)	Margin (dB)	Limit (dBuV/m)	Height (cm)	Angle (deg)	Remark (QP/PK/AV)
1	4904.000	40.69	0.44	41.14	-32.86	74.00	200	264	Peak
2	7356.000	38.94	5.62	44.56	-29.44	74.00	200	126	Peak
3	* 9808.000	43.65	5.37	49.02	-24.98	74.00	200	212	Peak

Note:

1. " \*", means this data is the worst emission level.
2. C.F (Correction Factor) = Antenna Factor (dB/m) + Cable Loss (dB) – Preamplifier(dB).
3. Measurement (dBuV/m) = Reading(dBuV) + C.F (Correction Factor).
4. The emission levels of other frequencies are very lower than the limit and not show in test report.

EUT	BE11000 Ceiling Mount Wi-Fi 7 Access Point	Date of Test	2024-05-27
Factor	DRH18-E	Temp. / Humidity	20°C /65%
Polarity	Horizontal	Site / Test Engineer	AC2 / You
Test Mode	802.11ax-20MHz_TX_CH 1 ANT 0+1	Test Voltage	AC 120V/60Hz

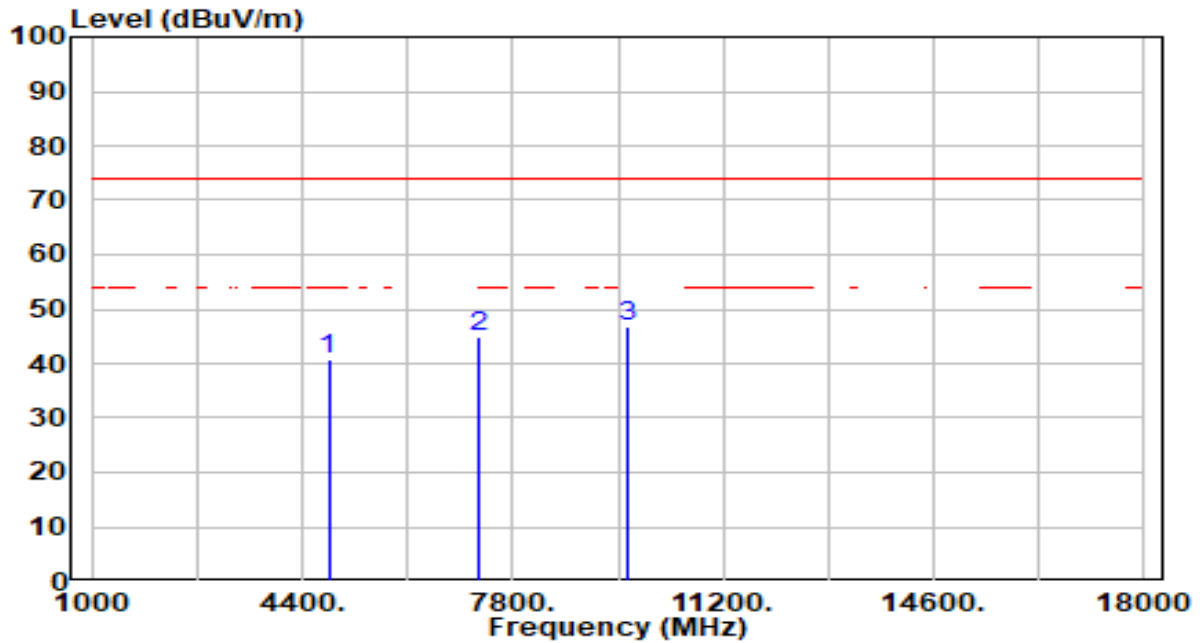

No	Frequency (MHz)	Reading (dBuV)	C.F (dB/m)	Measurement (dBuV/m)	Margin (dB)	Limit (dBuV/m)	Height (cm)	Angle (deg)	Remark (QP/PK/AV)
1	4824.000	40.60	0.23	40.83	-33.17	74.00	100	281	Peak
2	7236.000	39.26	5.54	44.81	-29.19	74.00	100	0	Peak
3	* 9648.000	41.51	5.30	46.81	-27.19	74.00	100	111	Peak

Note:

1. " \*", means this data is the worst emission level.
2. C.F (Correction Factor) = Antenna Factor (dB/m) + Cable Loss (dB) – Preamplifier(dB).
3. Measurement (dBuV/m) = Reading(dBuV) + C.F (Correction Factor).
4. The emission levels of other frequencies are very lower than the limit and not show in test report.

EUT	BE11000 Ceiling Mount Wi-Fi 7 Access Point	Date of Test	2024-05-27
Factor	DRH18-E	Temp. / Humidity	20°C /65%
Polarity	Vertical	Site / Test Engineer	AC2 / You
Test Mode	802.11ax-20MHz_TX_CH 1 ANT 0+1	Test Voltage	AC 120V/60Hz

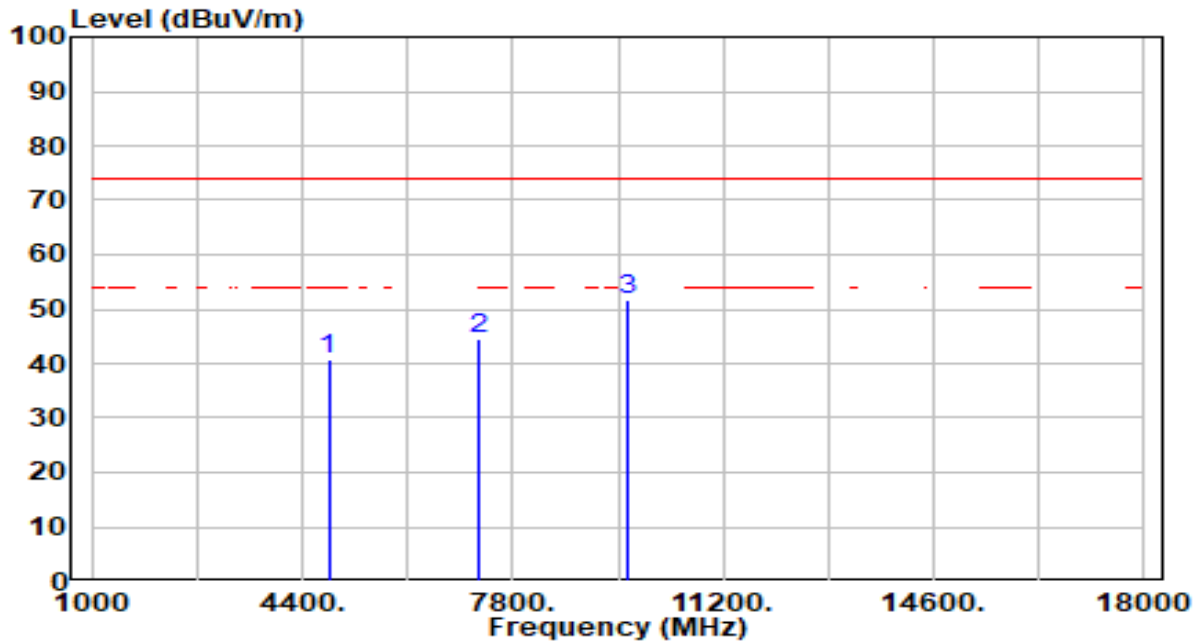

No	Frequency (MHz)	Reading (dBuV)	C.F (dB/m)	Measurement (dBuV/m)	Margin (dB)	Limit (dBuV/m)	Height (cm)	Angle (deg)	Remark (QP/PK/AV)
1	4824.000	40.67	0.23	40.90	-33.10	74.00	200	200	Peak
2	7236.000	39.10	5.54	44.64	-29.36	74.00	200	128	Peak
3	* 9648.000	46.33	5.30	51.63	-22.37	74.00	200	237	Peak

Note:

1. " \*", means this data is the worst emission level.
2. C.F (Correction Factor) = Antenna Factor (dB/m) + Cable Loss (dB) – Preamplifier(dB).
3. Measurement (dBuV/m) = Reading(dBuV) + C.F (Correction Factor).
4. The emission levels of other frequencies are very lower than the limit and not show in test report.

EUT	BE11000 Ceiling Mount Wi-Fi 7 Access Point	Date of Test	2024-05-27
Factor	DRH18-E	Temp. / Humidity	20°C /65%
Polarity	Horizontal	Site / Test Engineer	AC2 / You
Test Mode	802.11ax-20MHz_TX_CH 6 ANT 0+1	Test Voltage	AC 120V/60Hz

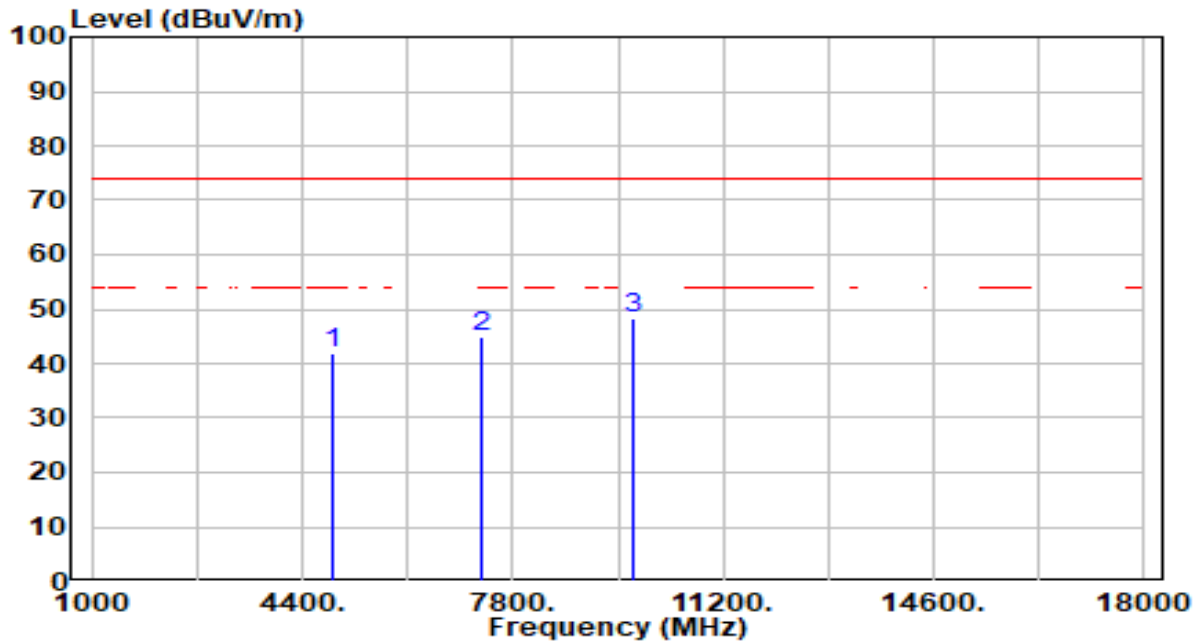

No	Frequency (MHz)	Reading (dBuV)	C.F (dB/m)	Measurement (dBuV/m)	Margin (dB)	Limit (dBuV/m)	Height (cm)	Angle (deg)	Remark (QP/PK/AV)
1	4874.000	41.54	0.36	41.90	-32.10	74.00	100	107	Peak
2	7311.000	39.28	5.59	44.87	-29.13	74.00	100	4	Peak
3	* 9748.000	43.03	5.34	48.38	-25.62	74.00	100	167	Peak

Note:

1. " \*", means this data is the worst emission level.
2. C.F (Correction Factor) = Antenna Factor (dB/m) + Cable Loss (dB) – Preamplifier(dB).
3. Measurement (dBuV/m) = Reading(dBuV) + C.F (Correction Factor).
4. The emission levels of other frequencies are very lower than the limit and not show in test report.

EUT	BE11000 Ceiling Mount Wi-Fi 7 Access Point	Date of Test	2024-05-27
Factor	DRH18-E	Temp. / Humidity	20°C /65%
Polarity	Vertical	Site / Test Engineer	AC2 / You
Test Mode	802.11ax-20MHz_TX_CH 6 ANT 0+1	Test Voltage	AC 120V/60Hz

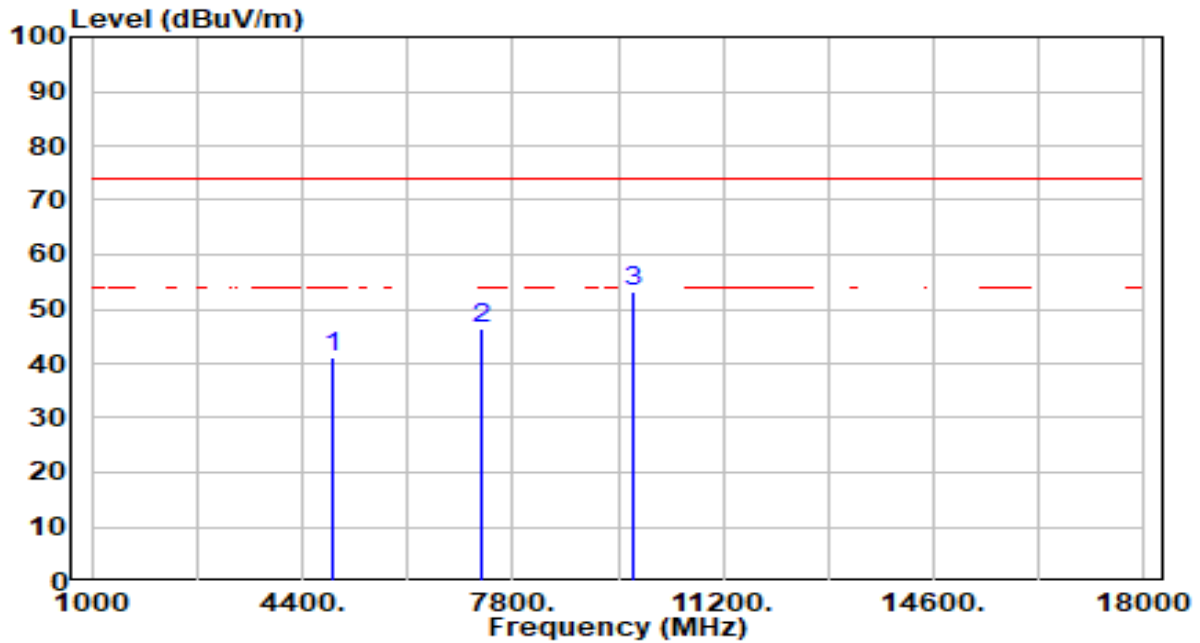

No	Frequency (MHz)	Reading (dBuV)	C.F (dB/m)	Measurement (dBuV/m)	Margin (dB)	Limit (dBuV/m)	Height (cm)	Angle (deg)	Remark (QP/PK/AV)
1	4874.000	40.68	0.36	41.04	-32.96	74.00	200	22	Peak
2	7311.000	40.67	5.59	46.26	-27.74	74.00	200	136	Peak
3	* 9748.000	47.87	5.34	53.22	-20.78	74.00	200	211	Peak

Note:

1. " \*", means this data is the worst emission level.
2. C.F (Correction Factor) = Antenna Factor (dB/m) + Cable Loss (dB) – Preamplifier(dB).
3. Measurement (dBuV/m) = Reading(dBuV) + C.F (Correction Factor).
4. The emission levels of other frequencies are very lower than the limit and not show in test report.

EUT	BE11000 Ceiling Mount Wi-Fi 7 Access Point	Date of Test	2024-05-27
Factor	DRH18-E	Temp. / Humidity	20°C /65%
Polarity	Horizontal	Site / Test Engineer	AC2 / You
Test Mode	802.11ax-20MHz_TX_CH 11 ANT 0+1	Test Voltage	AC 120V/60Hz

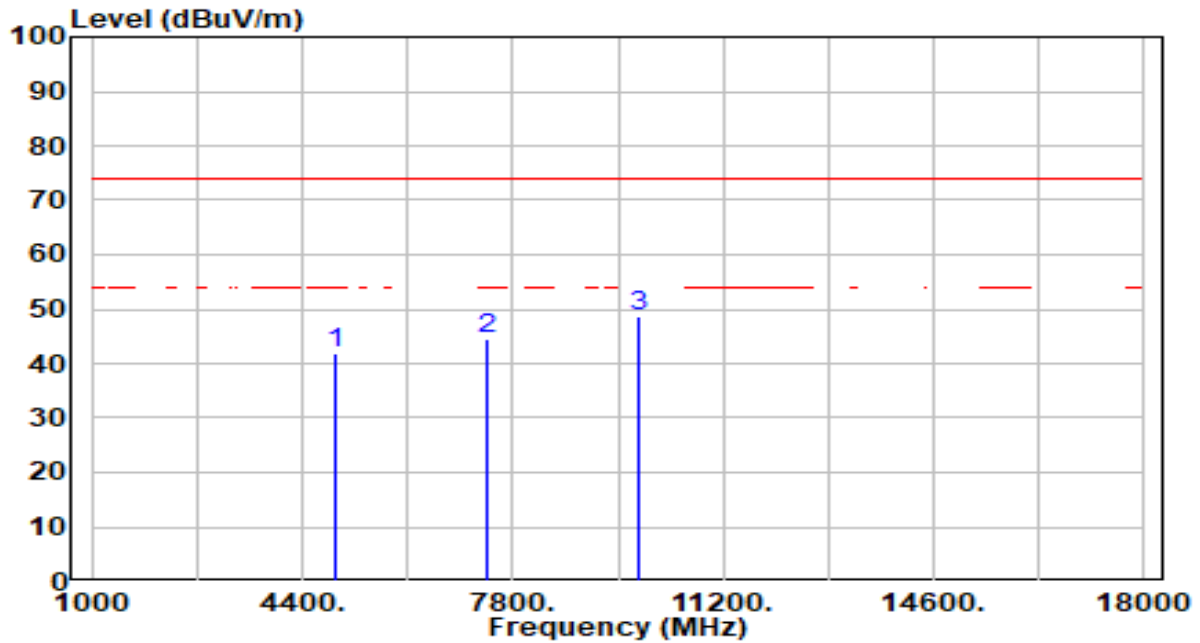

No	Frequency (MHz)	Reading (dBuV)	C.F (dB/m)	Measurement (dBuV/m)	Margin (dB)	Limit (dBuV/m)	Height (cm)	Angle (deg)	Remark (QP/PK/AV)
1	4924.000	41.24	0.49	41.73	-32.27	74.00	100	215	Peak
2	7386.000	38.74	5.64	44.37	-29.63	74.00	100	126	Peak
3	* 9848.000	43.14	5.39	48.52	-25.48	74.00	100	103	Peak

Note:

1. " \*", means this data is the worst emission level.
2. C.F (Correction Factor) = Antenna Factor (dB/m) + Cable Loss (dB) – Preamplifier(dB).
3. Measurement (dBuV/m) = Reading(dBuV) + C.F (Correction Factor).
4. The emission levels of other frequencies are very lower than the limit and not show in test report.



EUT	BE11000 Ceiling Mount Wi-Fi 7 Access Point	Date of Test	2024-05-27
Factor	DRH18-E	Temp. / Humidity	20°C /65%
Polarity	Vertical	Site / Test Engineer	AC2 / You
Test Mode	802.11ax-20MHz_TX_CH 11 ANT 0+1	Test Voltage	AC 120V/60Hz

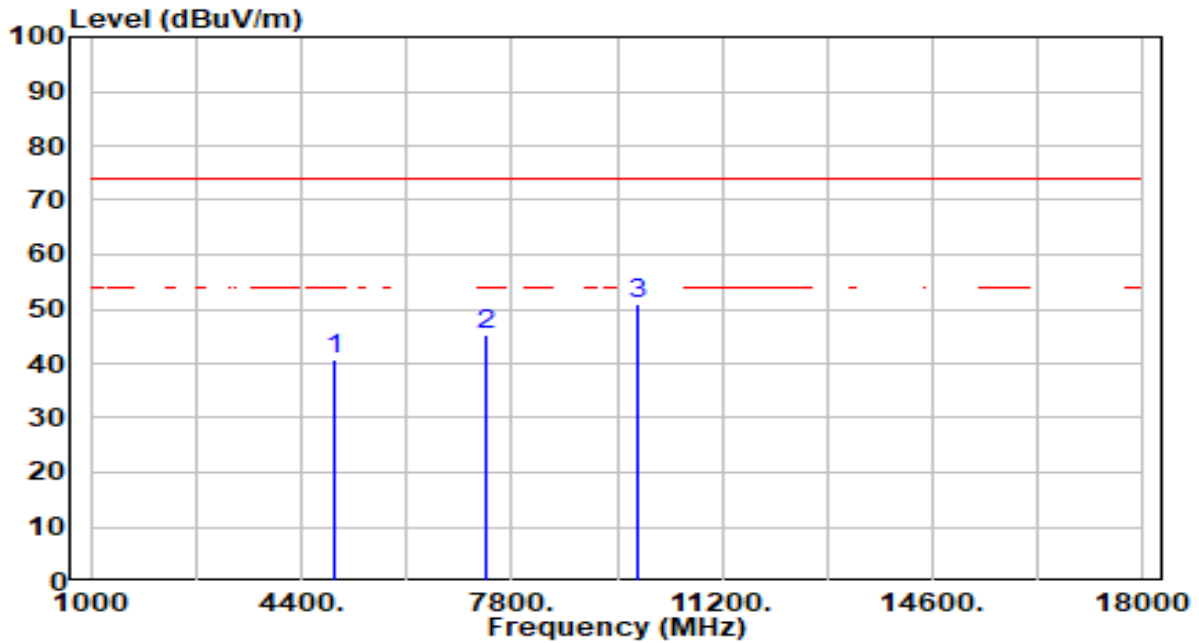

No	Frequency (MHz)	Reading (dBuV)	C.F (dB/m)	Measurement (dBuV/m)	Margin (dB)	Limit (dBuV/m)	Height (cm)	Angle (deg)	Remark (QP/PK/AV)
1	4924.000	40.26	0.49	40.75	-33.25	74.00	200	209	Peak
2	7386.000	39.57	5.64	45.21	-28.79	74.00	200	246	Peak
3	* 9848.000	45.59	5.39	50.98	-23.02	74.00	200	206	Peak

Note:

1. " \*", means this data is the worst emission level.
2. C.F (Correction Factor) = Antenna Factor (dB/m) + Cable Loss (dB) – Preamplifier(dB).
3. Measurement (dBuV/m) = Reading(dBuV) + C.F (Correction Factor).
4. The emission levels of other frequencies are very lower than the limit and not show in test report.

EUT	BE11000 Ceiling Mount Wi-Fi 7 Access Point	Date of Test	2024-05-27
Factor	DRH18-E	Temp. / Humidity	20°C /65%
Polarity	Horizontal	Site / Test Engineer	AC2 / You
Test Mode	802.11ax-40MHz_TX_CH 3 ANT 0+1	Test Voltage	AC 120V/60Hz

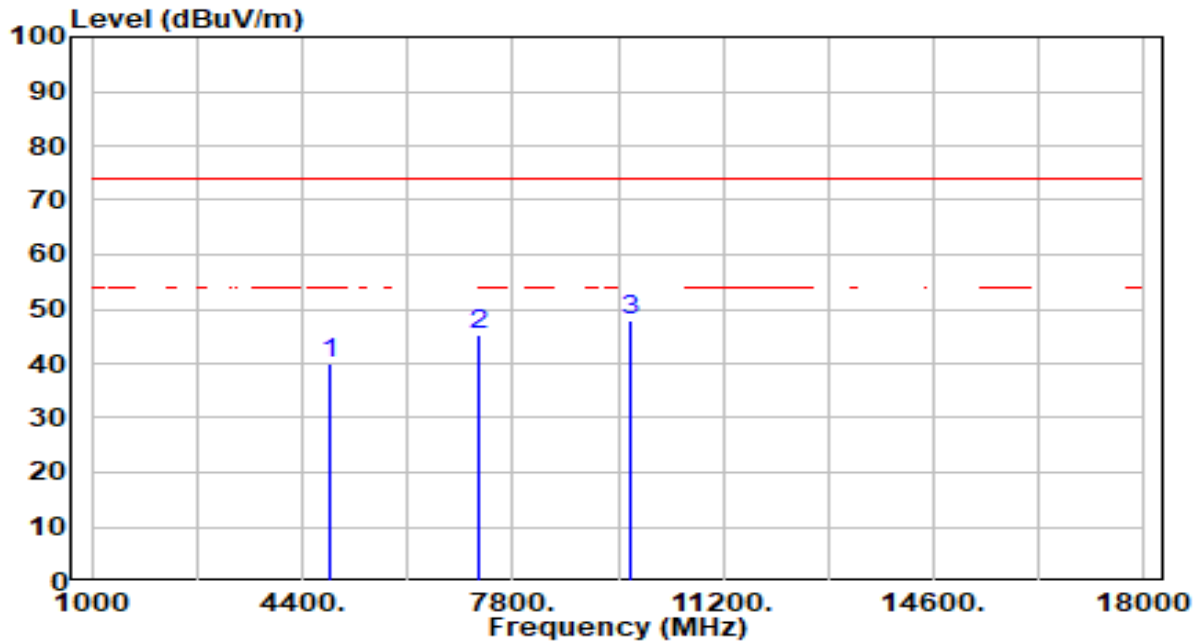

No	Frequency (MHz)	Reading (dBuV)	C.F (dB/m)	Measurement (dBuV/m)	Margin (dB)	Limit (dBuV/m)	Height (cm)	Angle (deg)	Remark (QP/PK/AV)
1	4844.000	39.72	0.28	40.01	-33.99	74.00	100	89	Peak
2	7266.000	39.59	5.56	45.16	-28.84	74.00	100	256	Peak
3	* 9688.000	42.61	5.32	47.92	-26.08	74.00	100	112	Peak

Note:

1. " \*", means this data is the worst emission level.
2. C.F (Correction Factor) = Antenna Factor (dB/m) + Cable Loss (dB) – Preamplifier(dB).
3. Measurement (dBuV/m) = Reading(dBuV) + C.F (Correction Factor).
4. The emission levels of other frequencies are very lower than the limit and not show in test report.

EUT	BE11000 Ceiling Mount Wi-Fi 7 Access Point	Date of Test	2024-05-27
Factor	DRH18-E	Temp. / Humidity	20°C /65%
Polarity	Vertical	Site / Test Engineer	AC2 / You
Test Mode	802.11ax-40MHz_TX_CH 3 ANT 0+1	Test Voltage	AC 120V/60Hz

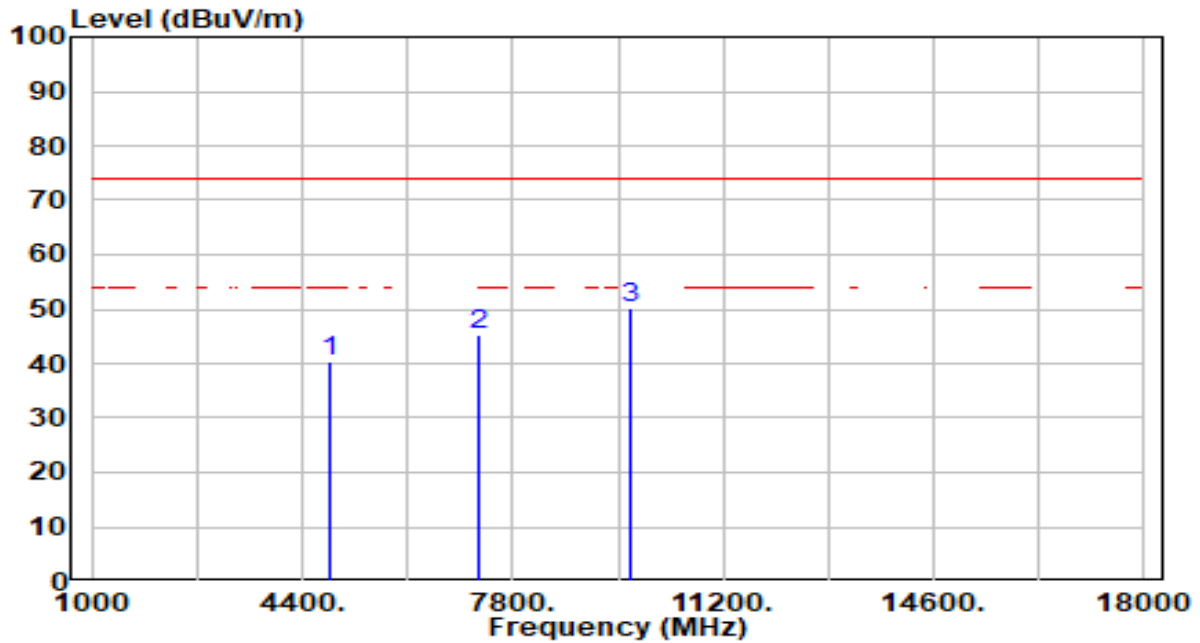

No	Frequency (MHz)	Reading (dBuV)	C.F (dB/m)	Measurement (dBuV/m)	Margin (dB)	Limit (dBuV/m)	Height (cm)	Angle (deg)	Remark (QP/PK/AV)
1	4844.000	40.07	0.28	40.36	-33.64	74.00	200	117	Peak
2	7266.000	39.73	5.56	45.30	-28.70	74.00	200	180	Peak
3	* 9688.000	44.74	5.32	50.06	-23.94	74.00	200	215	Peak

Note:

1. " \*", means this data is the worst emission level.
2. C.F (Correction Factor) = Antenna Factor (dB/m) + Cable Loss (dB) – Preamplifier(dB).
3. Measurement (dBuV/m) = Reading(dBuV) + C.F (Correction Factor).
4. The emission levels of other frequencies are very lower than the limit and not show in test report.

EUT	BE11000 Ceiling Mount Wi-Fi 7 Access Point	Date of Test	2024-05-27
Factor	DRH18-E	Temp. / Humidity	20°C /65%
Polarity	Horizontal	Site / Test Engineer	AC2 / You
Test Mode	802.11ax-40MHz_TX_CH 6 ANT 0+1	Test Voltage	AC 120V/60Hz

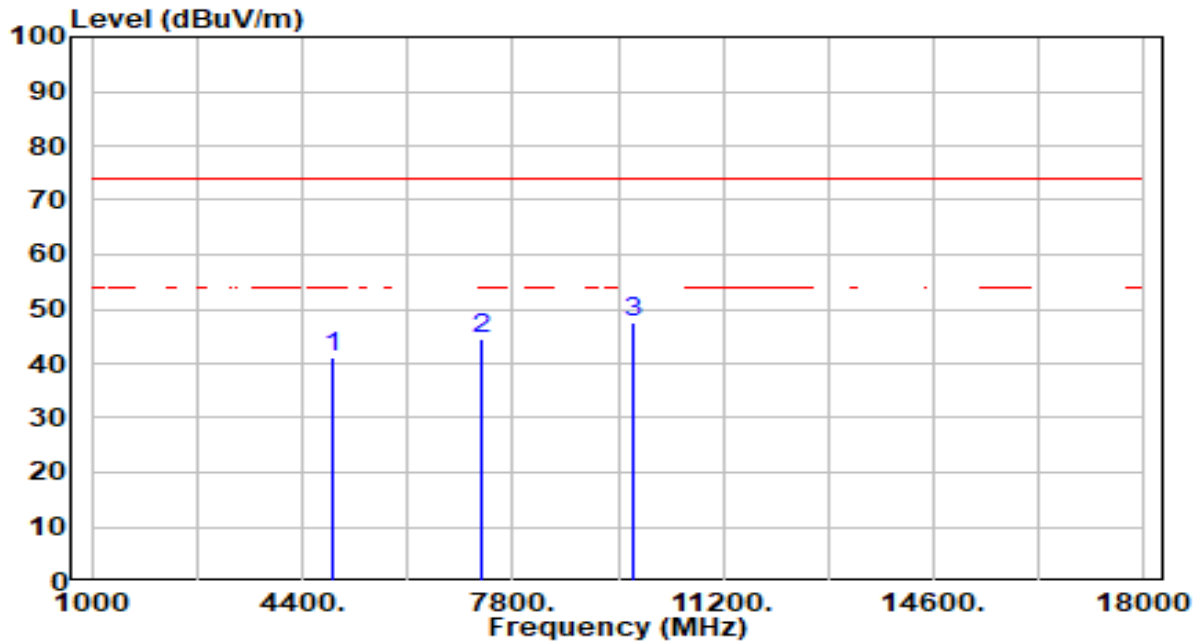

No	Frequency (MHz)	Reading (dBuV)	C.F (dB/m)	Measurement (dBuV/m)	Margin (dB)	Limit (dBuV/m)	Height (cm)	Angle (deg)	Remark (QP/PK/AV)
1	4874.000	40.69	0.36	41.05	-32.95	74.00	100	223	Peak
2	7311.000	38.94	5.59	44.53	-29.47	74.00	100	126	Peak
3	* 9748.000	42.20	5.34	47.54	-26.46	74.00	100	229	Peak

Note:

1. " \*", means this data is the worst emission level.
2. C.F (Correction Factor) = Antenna Factor (dB/m) + Cable Loss (dB) – Preamplifier(dB).
3. Measurement (dBuV/m) = Reading(dBuV) + C.F (Correction Factor).
4. The emission levels of other frequencies are very lower than the limit and not show in test report.

EUT	BE11000 Ceiling Mount Wi-Fi 7 Access Point	Date of Test	2024-05-27
Factor	DRH18-E	Temp. / Humidity	20°C /65%
Polarity	Vertical	Site / Test Engineer	AC2 / You
Test Mode	802.11ax-40MHz_TX_CH 6 ANT 0+1	Test Voltage	AC 120V/60Hz

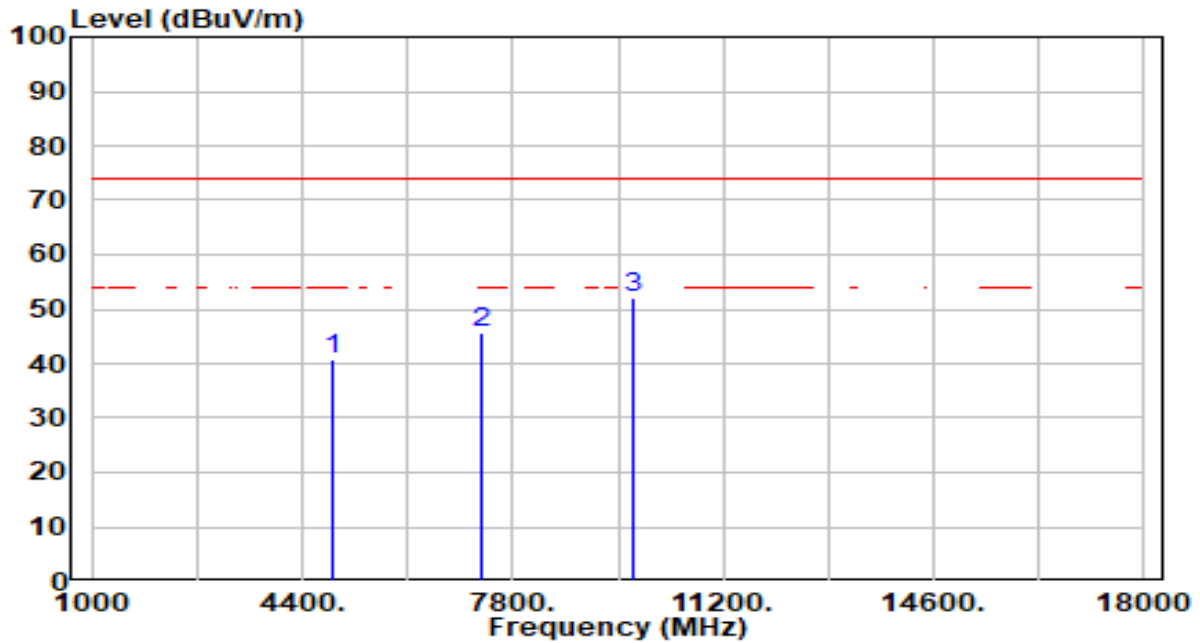

No	Frequency (MHz)	Reading (dBuV)	C.F (dB/m)	Measurement (dBuV/m)	Margin (dB)	Limit (dBuV/m)	Height (cm)	Angle (deg)	Remark (QP/PK/AV)
1	4874.000	40.33	0.36	40.69	-33.31	74.00	200	165	Peak
2	7311.000	39.99	5.59	45.58	-28.42	74.00	200	125	Peak
3	* 9748.000	46.70	5.34	52.04	-21.96	74.00	200	211	Peak

Note:

1. " \*", means this data is the worst emission level.
2. C.F (Correction Factor) = Antenna Factor (dB/m) + Cable Loss (dB) – Preamplifier(dB).
3. Measurement (dBuV/m) = Reading(dBuV) + C.F (Correction Factor).
4. The emission levels of other frequencies are very lower than the limit and not show in test report.

EUT	BE11000 Ceiling Mount Wi-Fi 7 Access Point	Date of Test	2024-05-27
Factor	DRH18-E	Temp. / Humidity	20°C /65%
Polarity	Horizontal	Site / Test Engineer	AC2 / You
Test Mode	802.11ax-40MHz_TX_CH 9 ANT 0+1	Test Voltage	AC 120V/60Hz

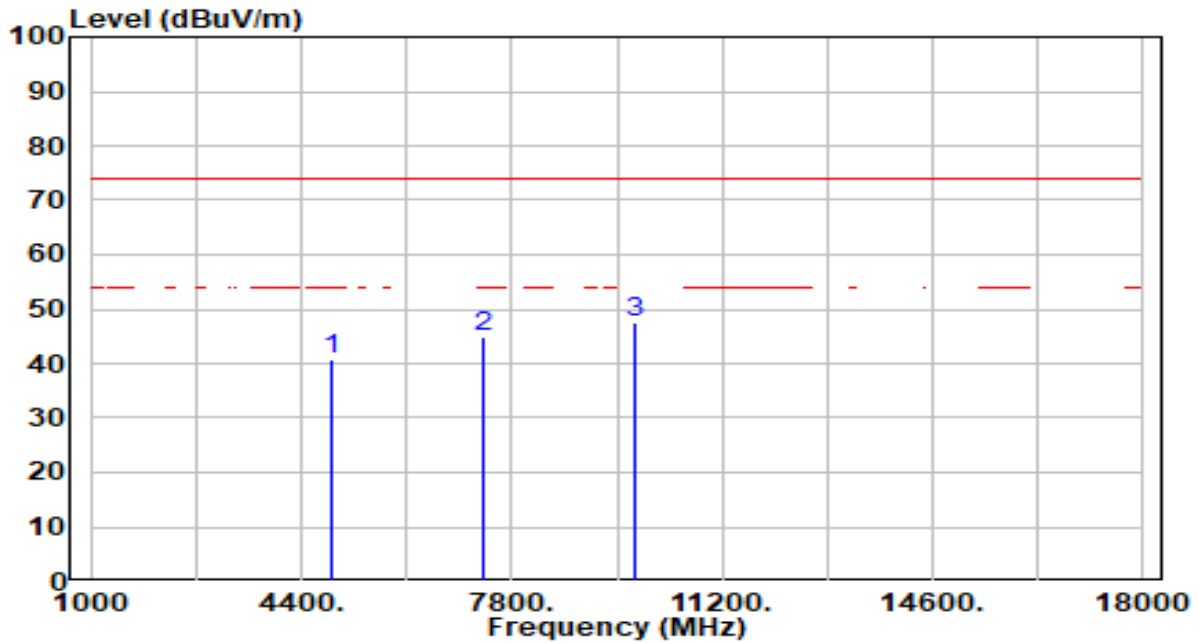

No	Frequency (MHz)	Reading (dBuV)	C.F (dB/m)	Measurement (dBuV/m)	Margin (dB)	Limit (dBuV/m)	Height (cm)	Angle (deg)	Remark (QP/PK/AV)
1	4904.000	40.27	0.44	40.71	-33.29	74.00	100	359	Peak
2	7356.000	39.12	5.62	44.74	-29.26	74.00	100	273	Peak
3	* 9808.000	42.08	5.37	47.45	-26.55	74.00	100	233	Peak

Note:

1. " \*", means this data is the worst emission level.
2. C.F (Correction Factor) = Antenna Factor (dB/m) + Cable Loss (dB) – Preamplifier(dB).
3. Measurement (dBuV/m) = Reading(dBuV) + C.F (Correction Factor).
4. The emission levels of other frequencies are very lower than the limit and not show in test report.

EUT	BE11000 Ceiling Mount Wi-Fi 7 Access Point	Date of Test	2024-05-27
Factor	DRH18-E	Temp. / Humidity	20°C /65%
Polarity	Vertical	Site / Test Engineer	AC2 / You
Test Mode	802.11ax-40MHz_TX_CH 9 ANT 0+1	Test Voltage	AC 120V/60Hz

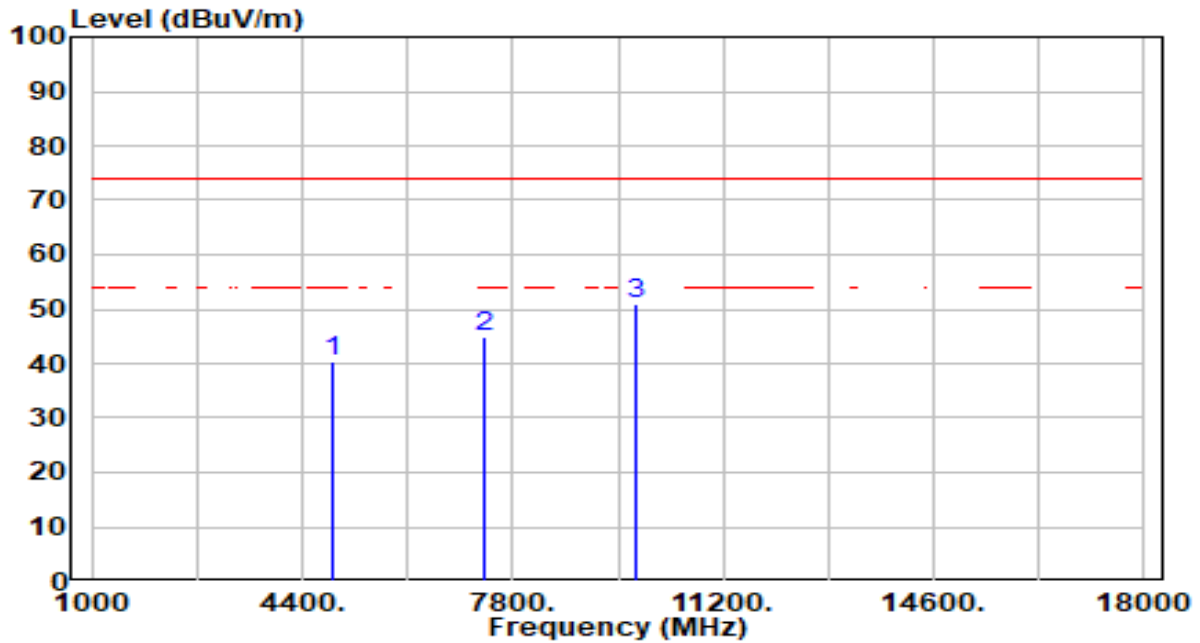

No	Frequency (MHz)	Reading (dBuV)	C.F (dB/m)	Measurement (dBuV/m)	Margin (dB)	Limit (dBuV/m)	Height (cm)	Angle (deg)	Remark (QP/PK/AV)
1	4904.000	39.97	0.44	40.41	-33.59	74.00	200	72	Peak
2	7356.000	39.21	5.62	44.83	-29.17	74.00	200	205	Peak
3	* 9808.000	45.64	5.37	51.01	-22.99	74.00	200	210	Peak

Note:

1. " \*", means this data is the worst emission level.
2. C.F (Correction Factor) = Antenna Factor (dB/m) + Cable Loss (dB) – Preamplifier(dB).
3. Measurement (dBuV/m) = Reading(dBuV) + C.F (Correction Factor).
4. The emission levels of other frequencies are very lower than the limit and not show in test report.

EUT	BE11000 Ceiling Mount Wi-Fi 7 Access Point	Date of Test	2024-05-27
Factor	DRH18-E	Temp. / Humidity	20°C /65%
Polarity	Horizontal	Site / Test Engineer	AC2 / You
Test Mode	802.11be-20MHz_TX_CH 1 ANT 0+1	Test Voltage	AC 120V/60Hz

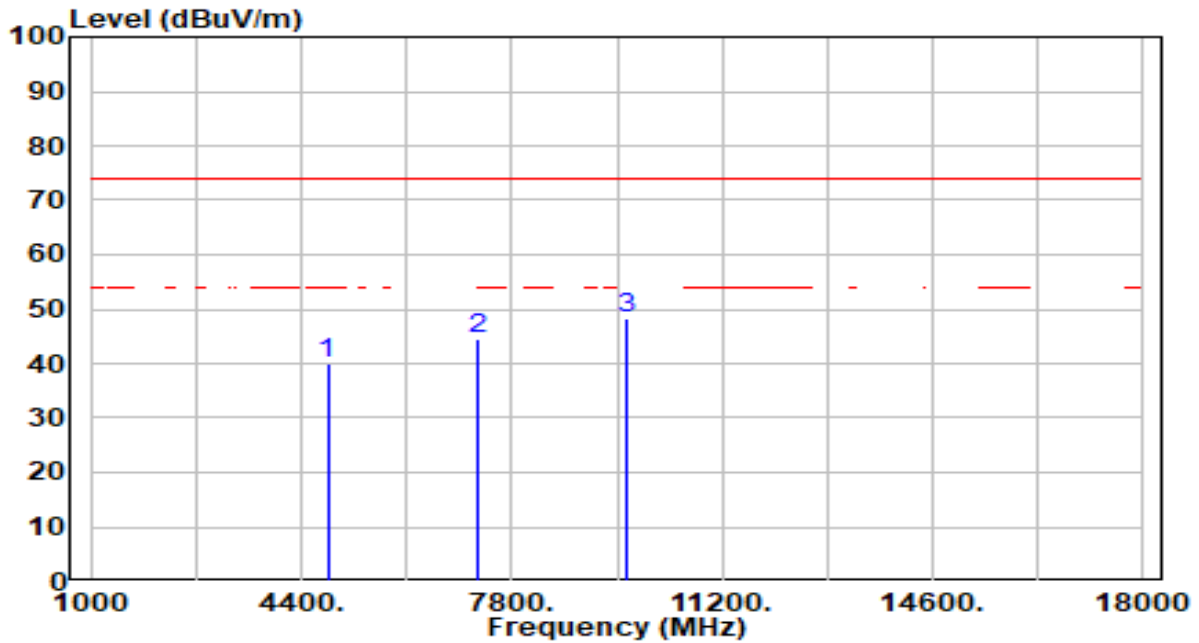

No	Frequency (MHz)	Reading (dBuV)	C.F (dB/m)	Measurement (dBuV/m)	Margin (dB)	Limit (dBuV/m)	Height (cm)	Angle (deg)	Remark (QP/PK/AV)
1	4824.000	39.86	0.23	40.09	-33.91	74.00	100	239	Peak
2	7236.000	39.06	5.54	44.60	-29.40	74.00	100	259	Peak
3	* 9648.000	42.98	5.30	48.28	-25.72	74.00	100	130	Peak

Note:

1. " \*", means this data is the worst emission level.
2. C.F (Correction Factor) = Antenna Factor (dB/m) + Cable Loss (dB) – Preamplifier(dB).
3. Measurement (dBuV/m) = Reading(dBuV) + C.F (Correction Factor).
4. The emission levels of other frequencies are very lower than the limit and not show in test report.



EUT	BE11000 Ceiling Mount Wi-Fi 7 Access Point	Date of Test	2024-05-27
Factor	DRH18-E	Temp. / Humidity	20°C /65%
Polarity	Vertical	Site / Test Engineer	AC2 / You
Test Mode	802.11be-20MHz_TX_CH 1 ANT 0+1	Test Voltage	AC 120V/60Hz

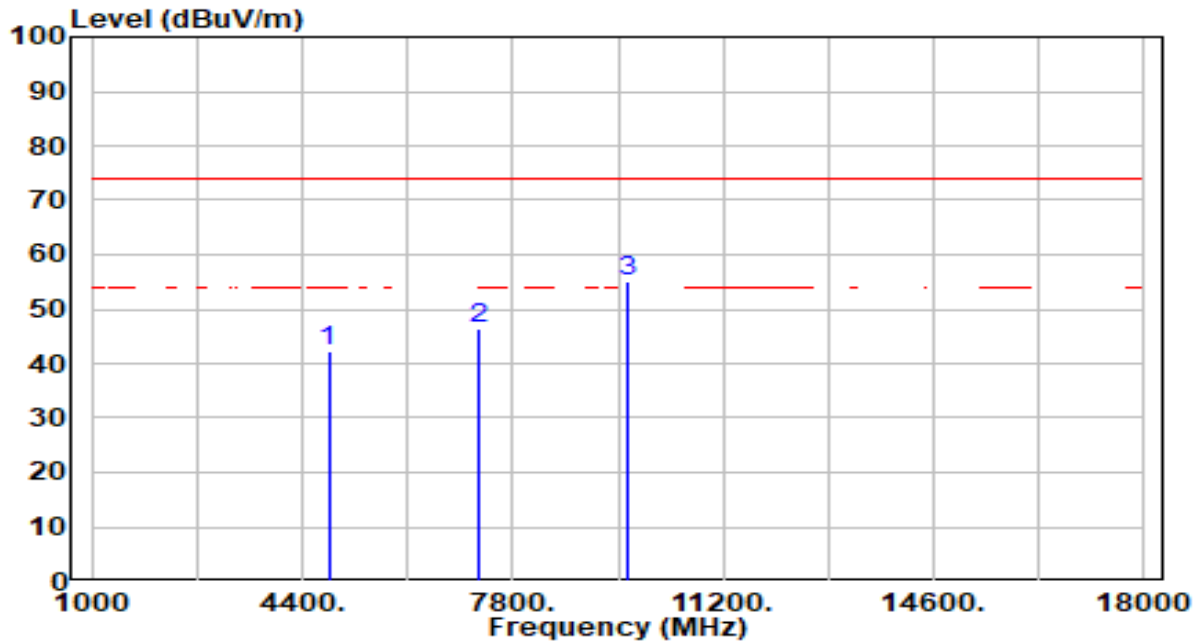

No	Frequency (MHz)	Reading (dBuV)	C.F (dB/m)	Measurement (dBuV/m)	Margin (dB)	Limit (dBuV/m)	Height (cm)	Angle (deg)	Remark (QP/PK/AV)
1	4824.000	41.95	0.23	42.18	-31.82	74.00	200	195	Peak
2	7236.000	40.78	5.54	46.32	-27.68	74.00	200	151	Peak
3	* 9648.000	49.80	5.30	55.10	-18.90	74.00	200	220	Peak

Note:

1. " \*", means this data is the worst emission level.
2. C.F (Correction Factor) = Antenna Factor (dB/m) + Cable Loss (dB) – Preamplifier(dB).
3. Measurement (dBuV/m) = Reading(dBuV) + C.F (Correction Factor).
4. The emission levels of other frequencies are very lower than the limit and not show in test report.

EUT	BE11000 Ceiling Mount Wi-Fi 7 Access Point	Date of Test	2024-05-27
Factor	DRH18-E	Temp. / Humidity	20°C /65%
Polarity	Horizontal	Site / Test Engineer	AC2 / You
Test Mode	802.11be-20MHz_TX_CH 6 ANT 0+1	Test Voltage	AC 120V/60Hz

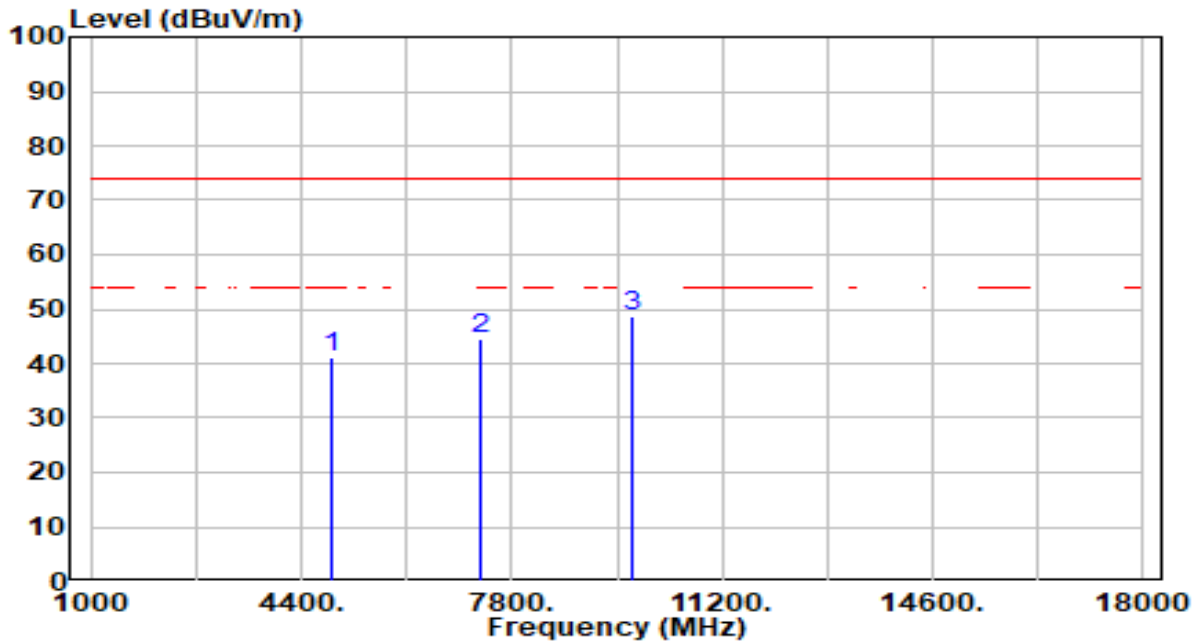

No	Frequency (MHz)	Reading (dBuV)	C.F (dB/m)	Measurement (dBuV/m)	Margin (dB)	Limit (dBuV/m)	Height (cm)	Angle (deg)	Remark (QP/PK/AV)
1	4874.000	40.90	0.36	41.27	-32.73	74.00	100	163	Peak
2	7311.000	38.93	5.59	44.52	-29.48	74.00	100	83	Peak
3	* 9748.000	43.31	5.34	48.65	-25.35	74.00	100	233	Peak

Note:

1. " \*", means this data is the worst emission level.
2. C.F (Correction Factor) = Antenna Factor (dB/m) + Cable Loss (dB) – Preamplifier(dB).
3. Measurement (dBuV/m) = Reading(dBuV) + C.F (Correction Factor).
4. The emission levels of other frequencies are very lower than the limit and not show in test report.

EUT	BE11000 Ceiling Mount Wi-Fi 7 Access Point	Date of Test	2024-05-27
Factor	DRH18-E	Temp. / Humidity	20°C /65%
Polarity	Vertical	Site / Test Engineer	AC2 / You
Test Mode	802.11be-20MHz_TX_CH 6 ANT 0+1	Test Voltage	AC 120V/60Hz

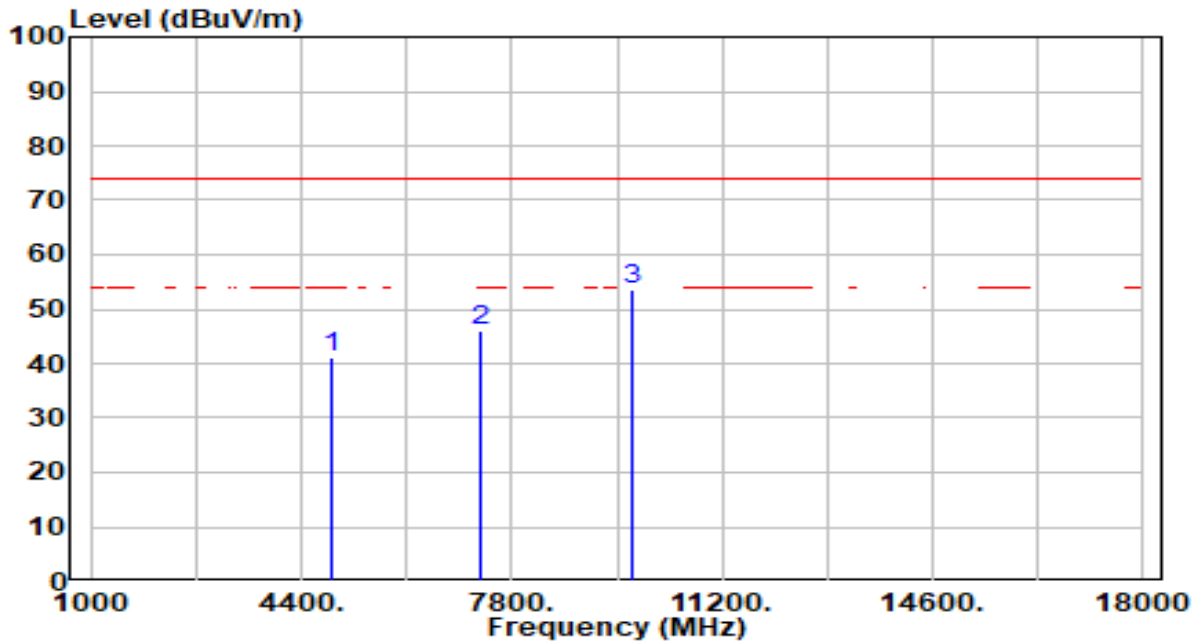

No	Frequency (MHz)	Reading (dBuV)	C.F (dB/m)	Measurement (dBuV/m)	Margin (dB)	Limit (dBuV/m)	Height (cm)	Angle (deg)	Remark (QP/PK/AV)
1	4874.000	40.64	0.36	41.00	-33.00	74.00	200	208	Peak
2	7311.000	40.47	5.59	46.06	-27.94	74.00	200	125	Peak
3	* 9748.000	48.32	5.34	53.66	-20.34	74.00	200	206	Peak

Note:

1. " \*", means this data is the worst emission level.
2. C.F (Correction Factor) = Antenna Factor (dB/m) + Cable Loss (dB) – Preamplifier(dB).
3. Measurement (dBuV/m) = Reading(dBuV) + C.F (Correction Factor).
4. The emission levels of other frequencies are very lower than the limit and not show in test report.

EUT	BE11000 Ceiling Mount Wi-Fi 7 Access Point	Date of Test	2024-05-27
Factor	DRH18-E	Temp. / Humidity	20°C /65%
Polarity	Vertical	Site / Test Engineer	AC2 / You
Test Mode	802.11be-20MHz_TX_CH 11 ANT 0+1	Test Voltage	AC 120V/60Hz

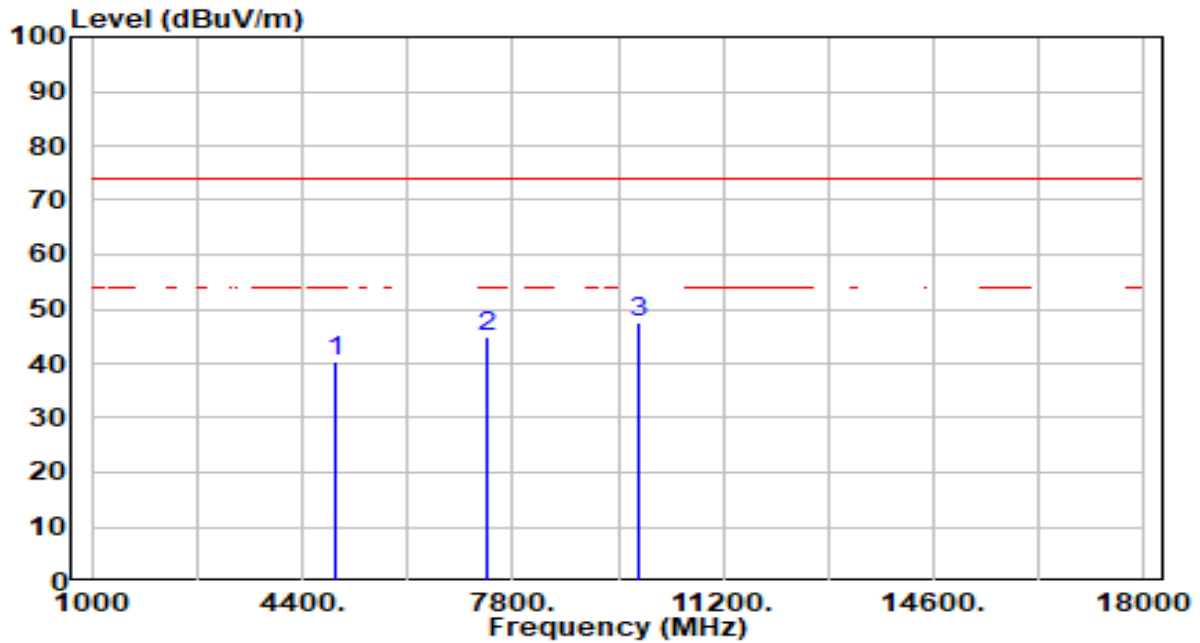

No	Frequency (MHz)	Reading (dBuV)	C.F (dB/m)	Measurement (dBuV/m)	Margin (dB)	Limit (dBuV/m)	Height (cm)	Angle (deg)	Remark (QP/PK/AV)
1	4924.000	39.82	0.49	40.31	-33.69	74.00	200	342	Peak
2	7386.000	39.21	5.64	44.85	-29.15	74.00	200	353	Peak
3	* 9848.000	42.32	5.39	47.71	-26.29	74.00	200	135	Peak

Note:

1. " \*", means this data is the worst emission level.
2. C.F (Correction Factor) = Antenna Factor (dB/m) + Cable Loss (dB) – Preamplifier(dB).
3. Measurement (dBuV/m) = Reading(dBuV) + C.F (Correction Factor).
4. The emission levels of other frequencies are very lower than the limit and not show in test report.

EUT	BE11000 Ceiling Mount Wi-Fi 7 Access Point	Date of Test	2024-05-27
Factor	DRH18-E	Temp. / Humidity	20°C /65%
Polarity	Vertical	Site / Test Engineer	AC2 / You
Test Mode	802.11be-20MHz_TX_CH 11 ANT 0+1	Test Voltage	AC 120V/60Hz

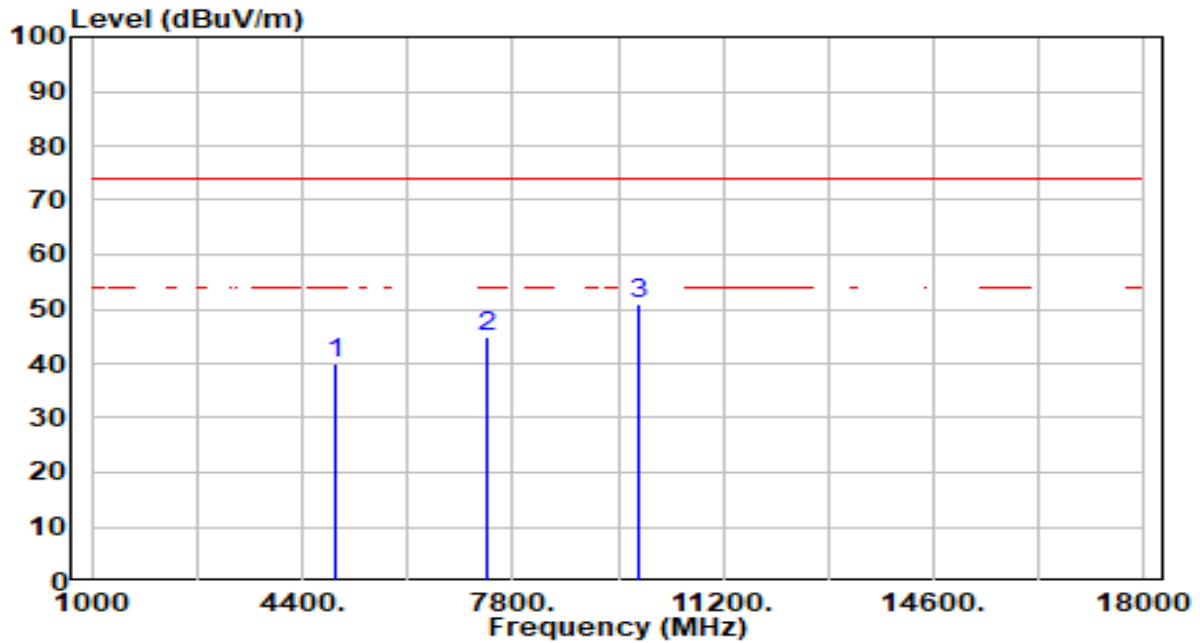

No	Frequency (MHz)	Reading (dBuV)	C.F (dB/m)	Measurement (dBuV/m)	Margin (dB)	Limit (dBuV/m)	Height (cm)	Angle (deg)	Remark (QP/PK/AV)
1	4924.000	39.48	0.49	39.97	-34.03	74.00	200	92	Peak
2	7386.000	39.26	5.64	44.90	-29.10	74.00	200	175	Peak
3	* 9848.000	45.43	5.39	50.82	-23.18	74.00	200	186	Peak

Note:

1. " \*", means this data is the worst emission level.
2. C.F (Correction Factor) = Antenna Factor (dB/m) + Cable Loss (dB) – Preamplifier(dB).
3. Measurement (dBuV/m) = Reading(dBuV) + C.F (Correction Factor).
4. The emission levels of other frequencies are very lower than the limit and not show in test report.

EUT	BE11000 Ceiling Mount Wi-Fi 7 Access Point	Date of Test	2024-05-27
Factor	DRH18-E	Temp. / Humidity	20°C /65%
Polarity	Horizontal	Site / Test Engineer	AC2 / You
Test Mode	802.11be-40MHz_TX_CH 3 ANT 0+1	Test Voltage	AC 120V/60Hz

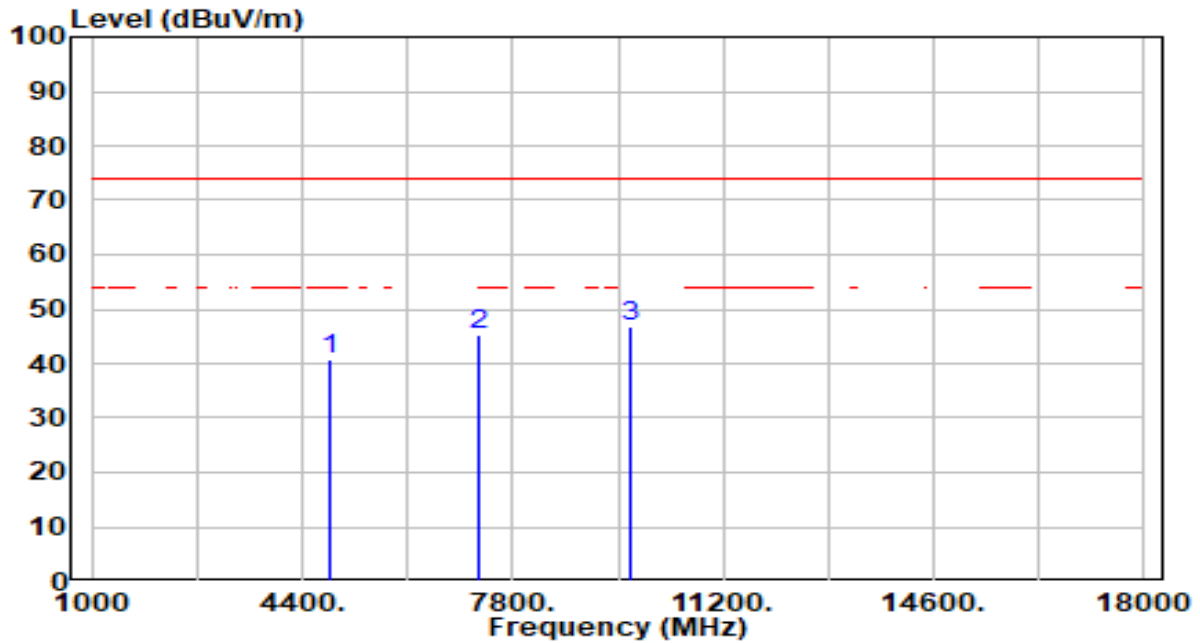

No	Frequency (MHz)	Reading (dBuV)	C.F (dB/m)	Measurement (dBuV/m)	Margin (dB)	Limit (dBuV/m)	Height (cm)	Angle (deg)	Remark (QP/PK/AV)
1	4844.000	40.57	0.28	40.86	-33.14	74.00	200	189	Peak
2	7266.000	39.84	5.56	45.41	-28.59	74.00	200	272	Peak
3	* 9688.000	41.53	5.32	46.85	-27.15	74.00	100	179	Peak

Note:

1. " \*", means this data is the worst emission level.
2. C.F (Correction Factor) = Antenna Factor (dB/m) + Cable Loss (dB) – Preamplifier(dB).
3. Measurement (dBuV/m) = Reading(dBuV) + C.F (Correction Factor).
4. The emission levels of other frequencies are very lower than the limit and not show in test report.

EUT	BE11000 Ceiling Mount Wi-Fi 7 Access Point	Date of Test	2024-05-27
Factor	DRH18-E	Temp. / Humidity	20°C /65%
Polarity	Vertical	Site / Test Engineer	AC2 / You
Test Mode	802.11be-40MHz_TX_CH 3 ANT 0+1	Test Voltage	AC 120V/60Hz

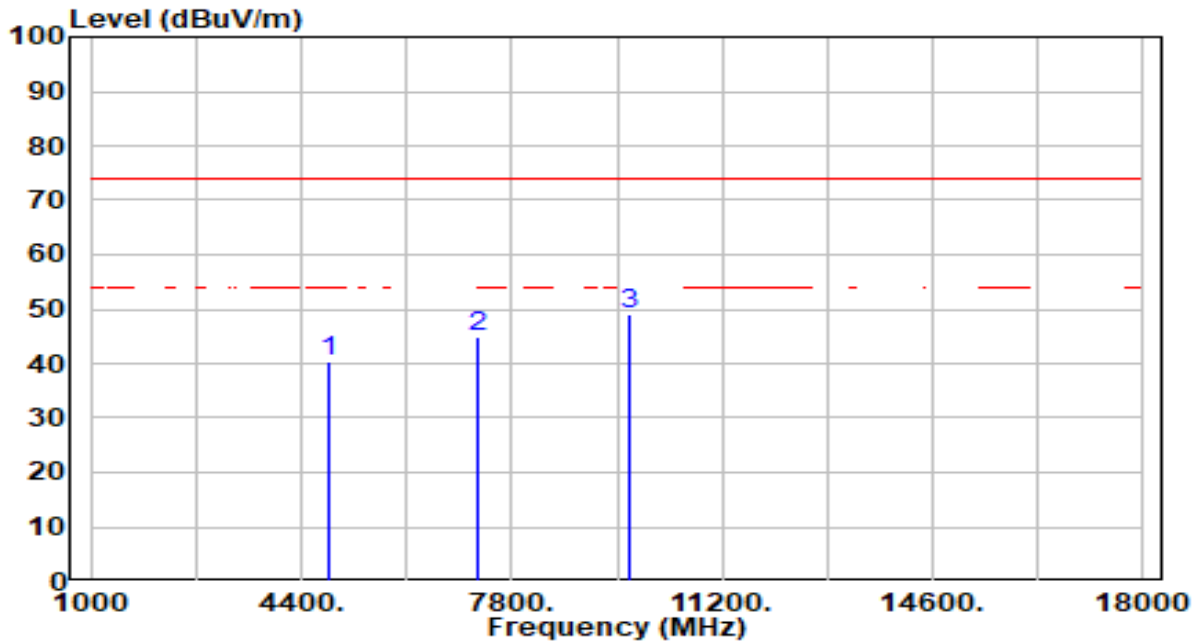

No	Frequency (MHz)	Reading (dBuV)	C.F (dB/m)	Measurement (dBuV/m)	Margin (dB)	Limit (dBuV/m)	Height (cm)	Angle (deg)	Remark (QP/PK/AV)
1	4844.000	40.12	0.28	40.40	-33.60	74.00	200	72	Peak
2	7266.000	39.23	5.56	44.79	-29.21	74.00	200	360	Peak
3	* 9688.000	43.89	5.32	49.20	-24.80	74.00	200	198	Peak

Note:

1. " \*", means this data is the worst emission level.
2. C.F (Correction Factor) = Antenna Factor (dB/m) + Cable Loss (dB) – Preamplifier(dB).
3. Measurement (dBuV/m) = Reading(dBuV) + C.F (Correction Factor).
4. The emission levels of other frequencies are very lower than the limit and not show in test report.

EUT	BE11000 Ceiling Mount Wi-Fi 7 Access Point	Date of Test	2024-05-27
Factor	DRH18-E	Temp. / Humidity	20°C /65%
Polarity	Horizontal	Site / Test Engineer	AC2 / You
Test Mode	802.11be-40MHz_TX_CH 6 ANT 0+1	Test Voltage	AC 120V/60Hz

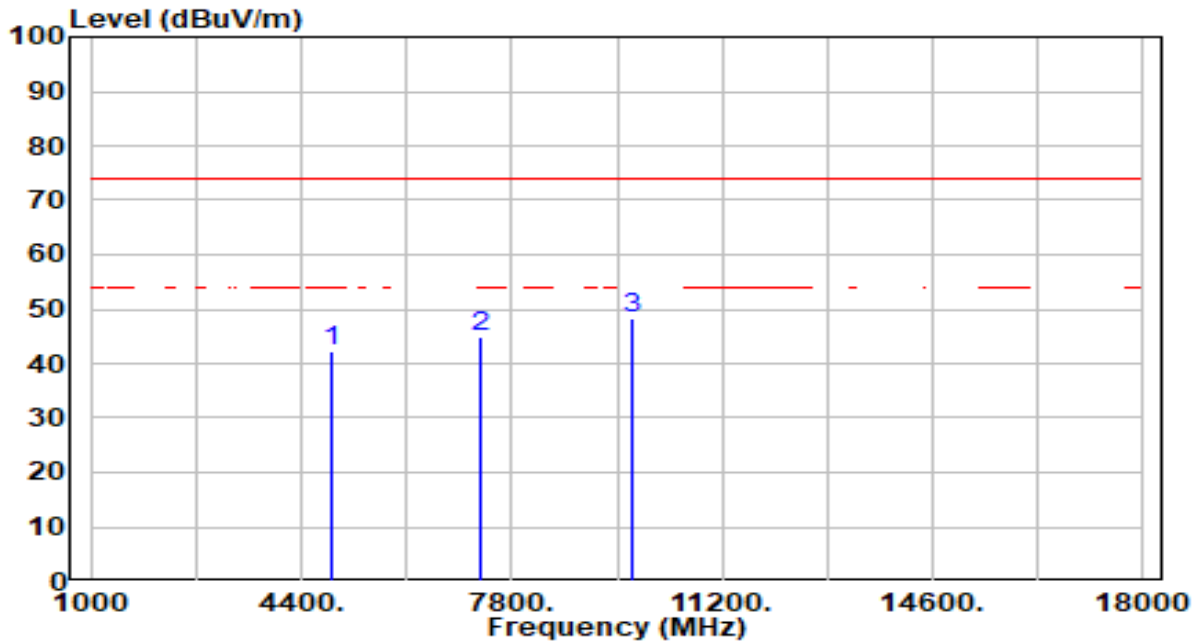

No	Frequency (MHz)	Reading (dBuV)	C.F (dB/m)	Measurement (dBuV/m)	Margin (dB)	Limit (dBuV/m)	Height (cm)	Angle (deg)	Remark (QP/PK/AV)
1	4874.000	41.72	0.36	42.08	-31.92	74.00	200	119	Peak
2	7311.000	39.31	5.59	44.90	-29.10	74.00	200	263	Peak
3	* 9748.000	42.89	5.34	48.23	-25.77	74.00	300	223	Peak

Note:

1. " \*", means this data is the worst emission level.
2. C.F (Correction Factor) = Antenna Factor (dB/m) + Cable Loss (dB) – Preamplifier(dB).
3. Measurement (dBuV/m) = Reading(dBuV) + C.F (Correction Factor).
4. The emission levels of other frequencies are very lower than the limit and not show in test report.



EUT	BE11000 Ceiling Mount Wi-Fi 7 Access Point	Date of Test	2024-05-27
Factor	DRH18-E	Temp. / Humidity	20°C /65%
Polarity	Vertical	Site / Test Engineer	AC2 / You
Test Mode	802.11be-40MHz_TX_CH 6 ANT 0+1	Test Voltage	AC 120V/60Hz

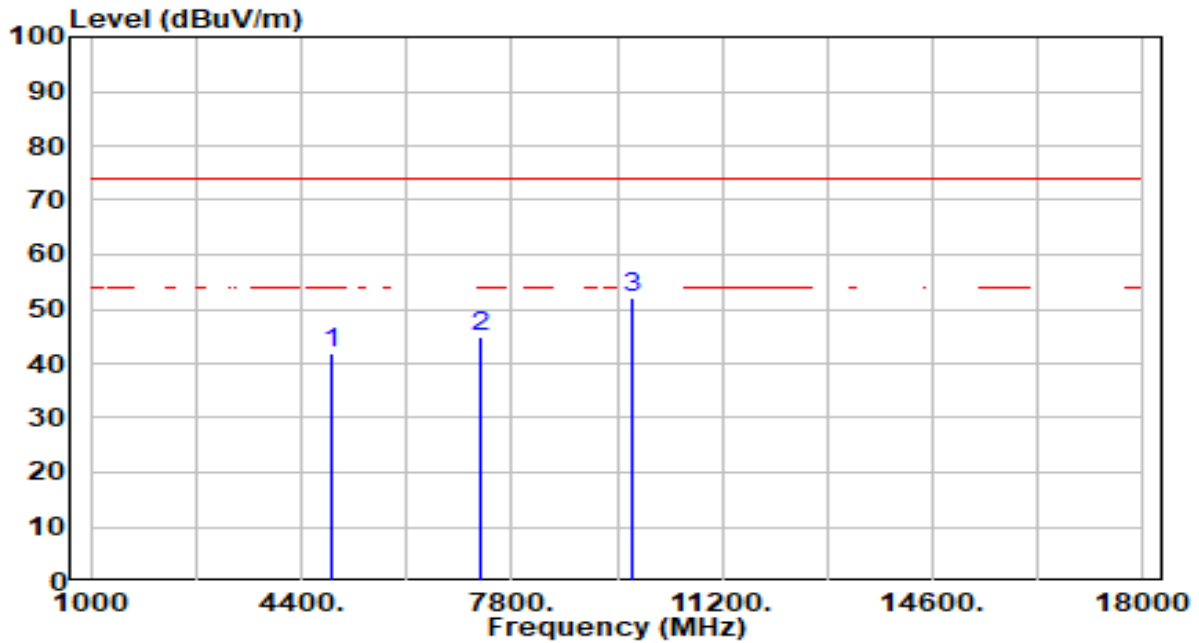

No	Frequency (MHz)	Reading (dBuV)	C.F (dB/m)	Measurement (dBuV/m)	Margin (dB)	Limit (dBuV/m)	Height (cm)	Angle (deg)	Remark (QP/PK/AV)
1	4874.000	41.40	0.36	41.76	-32.24	74.00	200	172	Peak
2	7311.000	39.28	5.59	44.87	-29.13	74.00	200	146	Peak
3	* 9748.000	46.72	5.34	52.06	-21.94	74.00	200	214	Peak

Note:

1. " \*", means this data is the worst emission level.
2. C.F (Correction Factor) = Antenna Factor (dB/m) + Cable Loss (dB) – Preamplifier(dB).
3. Measurement (dBuV/m) = Reading(dBuV) + C.F (Correction Factor).
4. The emission levels of other frequencies are very lower than the limit and not show in test report.

EUT	BE11000 Ceiling Mount Wi-Fi 7 Access Point	Date of Test	2024-05-27
Factor	DRH18-E	Temp. / Humidity	20°C /65%
Polarity	Horizontal	Site / Test Engineer	AC2 / You
Test Mode	802.11be-40MHz_TX_CH 9 ANT 0+1	Test Voltage	AC 120V/60Hz

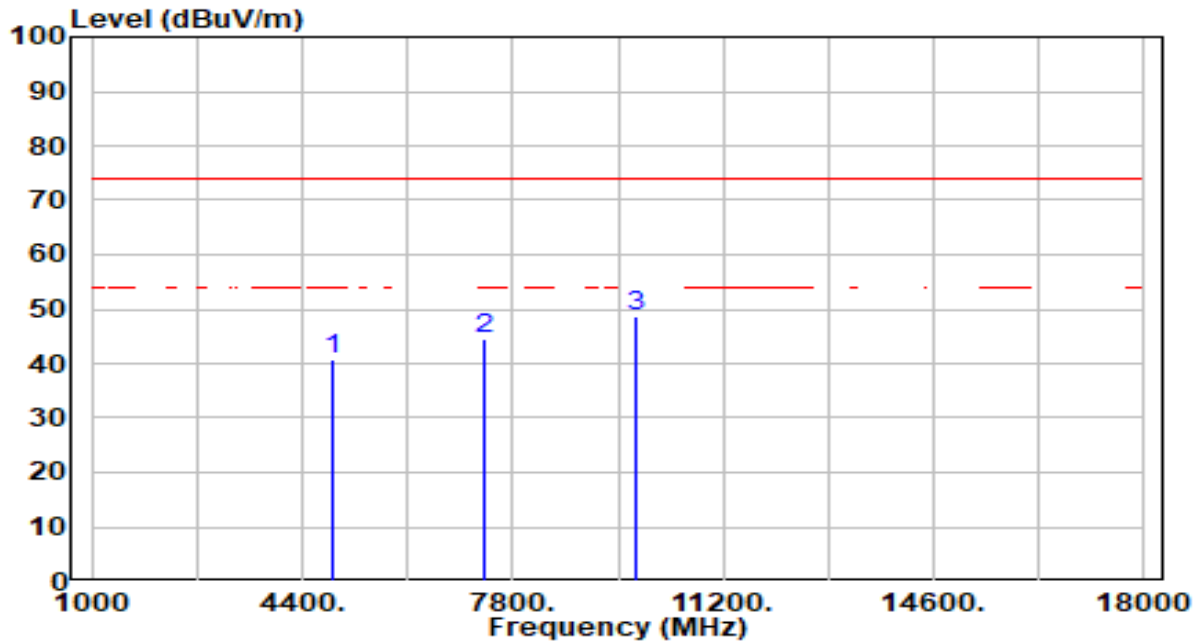

No	Frequency (MHz)	Reading (dBuV)	C.F (dB/m)	Measurement (dBuV/m)	Margin (dB)	Limit (dBuV/m)	Height (cm)	Angle (deg)	Remark (QP/PK/AV)
1	4904.000	40.21	0.44	40.65	-33.35	74.00	100	360	Peak
2	7356.000	38.84	5.62	44.45	-29.55	74.00	100	360	Peak
3	* 9808.000	43.26	5.37	48.63	-25.37	74.00	300	227	Peak

Note:

1. " \*", means this data is the worst emission level.
2. C.F (Correction Factor) = Antenna Factor (dB/m) + Cable Loss (dB) – Preamplifier(dB).
3. Measurement (dBuV/m) = Reading(dBuV) + C.F (Correction Factor).
4. The emission levels of other frequencies are very lower than the limit and not show in test report.

EUT	BE11000 Ceiling Mount Wi-Fi 7 Access Point	Date of Test	2024-05-27
Factor	DRH18-E	Temp. / Humidity	20°C /65%
Polarity	Vertical	Site / Test Engineer	AC2 / You
Test Mode	802.11be-40MHz_TX_CH 9 ANT 0+1	Test Voltage	AC 120V/60Hz

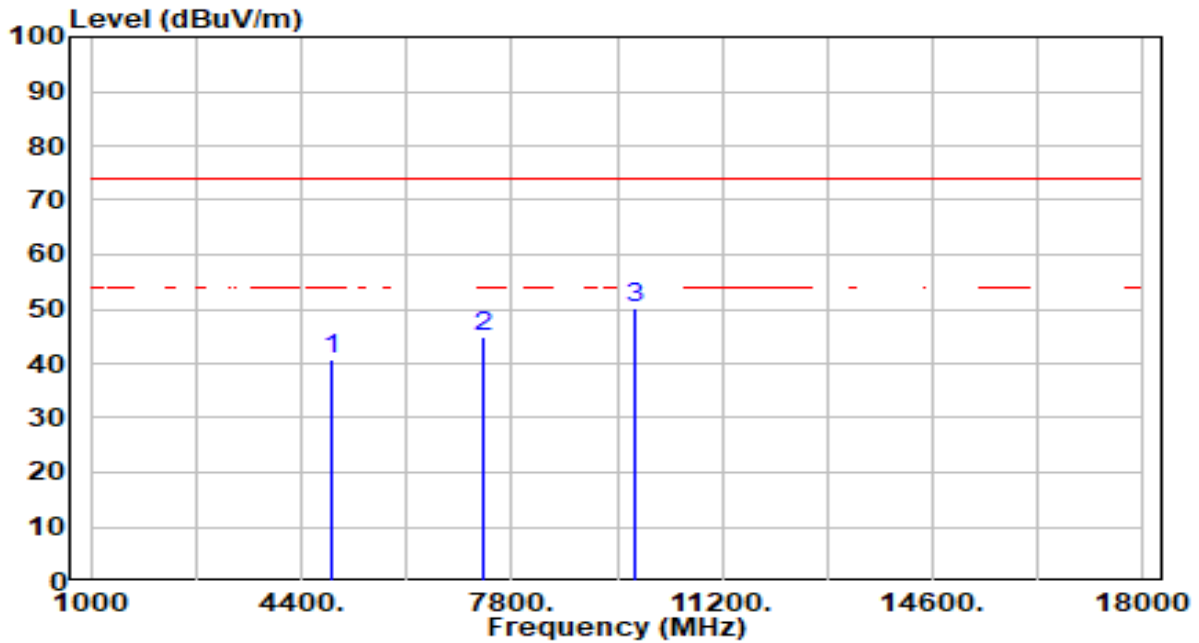

No	Frequency (MHz)	Reading (dBuV)	C.F (dB/m)	Measurement (dBuV/m)	Margin (dB)	Limit (dBuV/m)	Height (cm)	Angle (deg)	Remark (QP/PK/AV)
1	4904.000	40.45	0.44	40.89	-33.11	74.00	100	112	Peak
2	7356.000	39.43	5.62	45.05	-28.95	74.00	200	119	Peak
3	* 9808.000	44.67	5.37	50.04	-23.96	74.00	200	196	Peak

Note:

1. " \*", means this data is the worst emission level.
2. C.F (Correction Factor) = Antenna Factor (dB/m) + Cable Loss (dB) – Preamplifier(dB).
3. Measurement (dBuV/m) = Reading(dBuV) + C.F (Correction Factor).
4. The emission levels of other frequencies are very lower than the limit and not show in test report.

EUT	BE11000 Ceiling Mount Wi-Fi 7 Access Point	Date of Test	2024-06-18
Factor	BBHA 9170	Temp. / Humidity	22°C /61%
Polarity	Horizontal	Site / Test Engineer	AC2 / Stanley
Test Mode	802.11n-20MHz_TX_CH 6_ANT 0+1	Test Voltage	AC 120V/60Hz

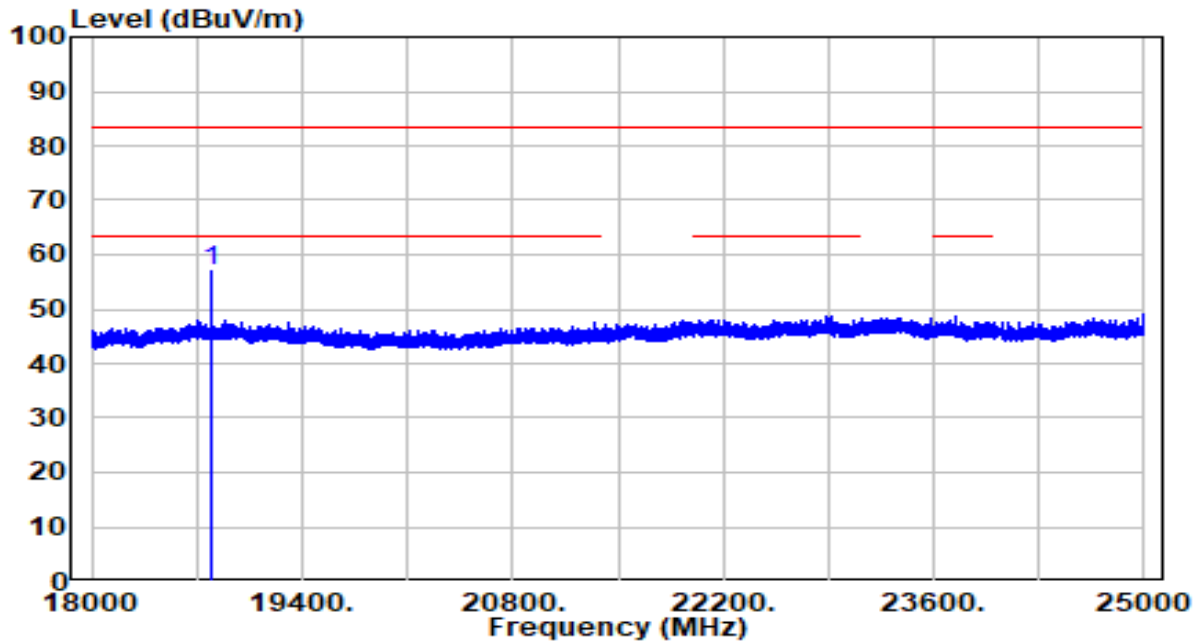

No	Frequency (MHz)	Reading (dBuV)	C.F (dB/m)	Measurement (dBuV/m)	Margin (dB)	Limit (dBuV/m)	Height (cm)	Angle (deg)	Remark (QP/PK/AV)	
1	*	18794.710	45.59	11.32	56.91	-26.59	83.50	150	360	Peak

Note:

1. " \*", means this data is the worst emission level.
2. C.F (Correction Factor) = Antenna Factor (dB/m) + Cable Loss (dB) – Preamplifier(dB).
3. Measurement (dBuV/m) = Reading(dBuV) + C.F (Correction Factor).
4. The emission levels of other frequencies are very lower than the limit and not show in test report.

EUT	BE11000 Ceiling Mount Wi-Fi 7 Access Point	Date of Test	2024-06-18
Factor	BBHA 9170	Temp. / Humidity	22°C /61%
Polarity	Vertical	Site / Test Engineer	AC2 / Stanley
Test Mode	802.11n-20MHz_TX_CH 6_ANT 0+1	Test Voltage	AC 120V/60Hz

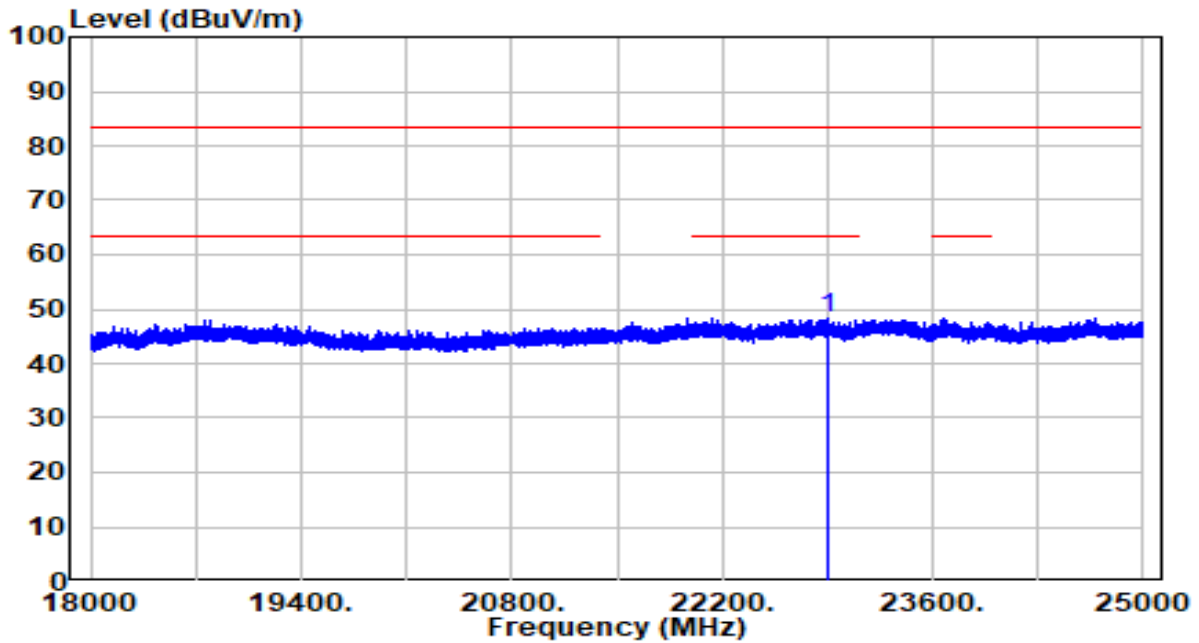

No	Frequency (MHz)	Reading (dBuV)	C.F (dB/m)	Measurement (dBuV/m)	Margin (dB)	Limit (dBuV/m)	Height (cm)	Angle (deg)	Remark (QP/PK/AV)	
1	*	22907.000	36.18	12.22	48.40	-35.10	83.50	150	0	Peak

Note:

1. " \*", means this data is the worst emission level.
2. C.F (Correction Factor) = Antenna Factor (dB/m) + Cable Loss (dB) – Preamplifier(dB).
3. Measurement (dBuV/m) = Reading(dBuV) + C.F (Correction Factor).
4. The emission levels of other frequencies are very lower than the limit and not show in test report.

## 7.7. Radiated Restricted Band Edge Measurement

### 7.7.1. Test Limit

**For 15.205 requirement:**

Radiated emissions which fall in the restricted bands, as defined in Section 15.205(a) of FCC part 15, must also comply with the radiated emission limits specified in Section 15.209(a).

Frequency (MHz)	Frequency (MHz)	Frequency (MHz)	Frequency (GHz)
0.090 - 0.110	16.42 - 16.423	399.9 - 410	4.5 - 5.15
<sup>1</sup> 0.495 - 0.505	16.69475 - 16.69525	608 - 614	5.35 - 5.46
2.1735 - 2.1905	16.80425 - 16.80475	960 - 1240	7.25 - 7.75
4.125 - 4.128	25.5 - 25.67	1300 - 1427	8.025 - 8.5
4.17725 - 4.17775	37.5 - 38.25	1435 - 1626.5	9.0 - 9.2
4.20725 - 4.20775	73 - 74.6	1645.5 - 1646.5	9.3 - 9.5
6.215 - 6.218	74.8 - 75.2	1660 - 1710	10.6 - 12.7
6.26775 - 6.26825	108 - 121.94	1718.8 - 1722.2	13.25 - 13.4
6.31175 - 6.31225	123 - 138	2200 - 2300	14.47 - 14.5
8.291 - 8.294	149.9 - 150.05	2310 - 2390	15.35 - 16.2
8.362 - 8.366	156.52475 - 156.52525	2483.5 - 2500	17.7 - 21.4
8.37625 - 8.38675	156.7 - 156.9	2690 - 2900	22.01 - 23.12
8.41425 - 8.41475	162.0125 - 167.17	3260 - 3267	23.6 - 24.0
12.29 - 12.293	167.72 - 173.2	3332 - 3339	31.2 - 31.8
12.51975 - 12.52025	240 - 285	3345.8 - 3358	36.43 - 36.5
12.57675 - 12.57725	322 - 335.4	3600 - 4400	( <sup>2</sup> )
13.36 - 13.41	--	--	--

All out of band emissions appearing in a restricted band as specified in Section 15.205 of the Title 47CFR must not exceed the limits shown in Table per Section 15.209.

FCC Part 15 Subpart C Paragraph 15.209 Limits		
Frequency [MHz]	Field Strength [uV/m]	Measured Distance [Meters]
0.009 - 0.490	2400/F (kHz)	300
0.490 - 1.705	24000/F (kHz)	30
1.705 - 30	30	30
30 - 88	100	3
88 - 216	150	3
216 - 960	200	3
Above 960	500	3

### 7.7.2. Test Procedure Used

ANSI C63.10 - 2013 Section 6.3 (General Requirements)

ANSI C63.10 - 2013 Section 6.6 (Standard test method above 1GHz)

### 7.7.3. Test Setting

#### Peak Field Strength Measurements

1. Analyzer center frequency was set to the frequency of the radiated spurious emission of interest
2. RBW = 1MHz
3. VBW = 3MHz
4. Detector = peak
5. Sweep time = auto couple
6. Trace mode = max hold
7. Trace was allowed to stabilize

### Average Measurements above 1GHz (Method VB)

1. Analyzer center frequency was set to the frequency of the radiated spurious emission of interest
2. RBW = 1MHz
3. VBW; If the EUT is configured to transmit with duty cycle  $\geq 98\%$ , set VBW = 10 Hz.

If the EUT duty cycle is  $< 98\%$ , set  $VBW \geq 1/T$ . T is the minimum transmission duration.

4. Detector = Peak
5. Sweep time = auto
6. Trace mode = max hold
7. Trace was allowed to stabilize

#### 7.7.4. Test Setup

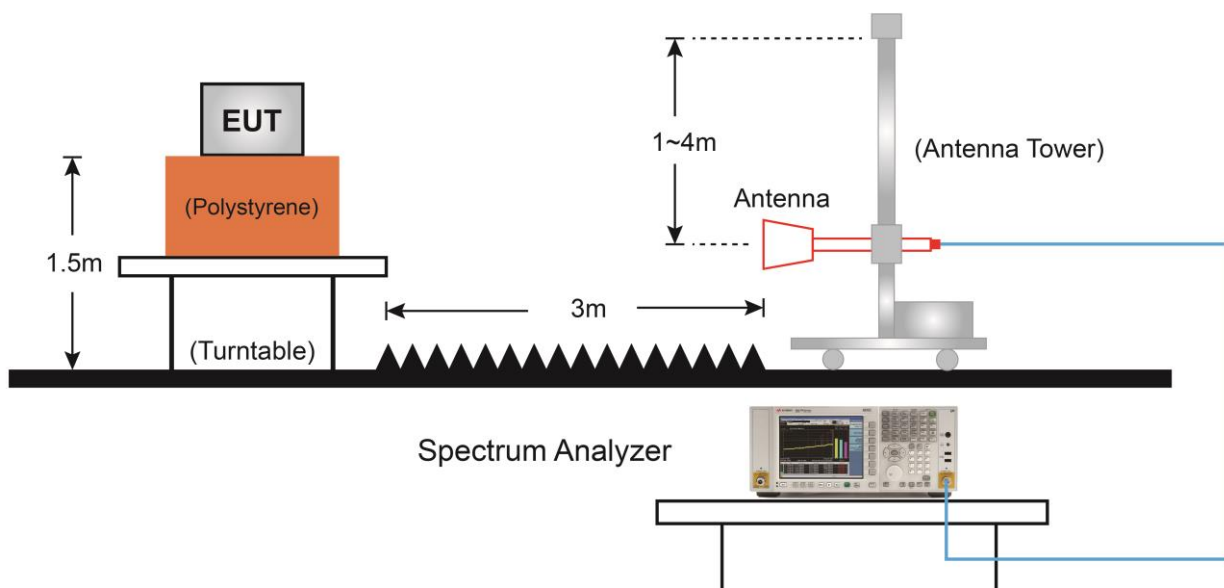



### 7.7.5. Test Result

EUT	BE11000 Ceiling Mount Wi-Fi 7 Access Point	Date of Test	2024-05-27
Factor	DRH18-E	Temp. / Humidity	20°C /65%
Polarity	Horizontal	Site / Test Engineer	AC2 / You
Test Mode	802.11b_TX_CH 1 ANT 0+1	Test Voltage	AC 120V/60Hz

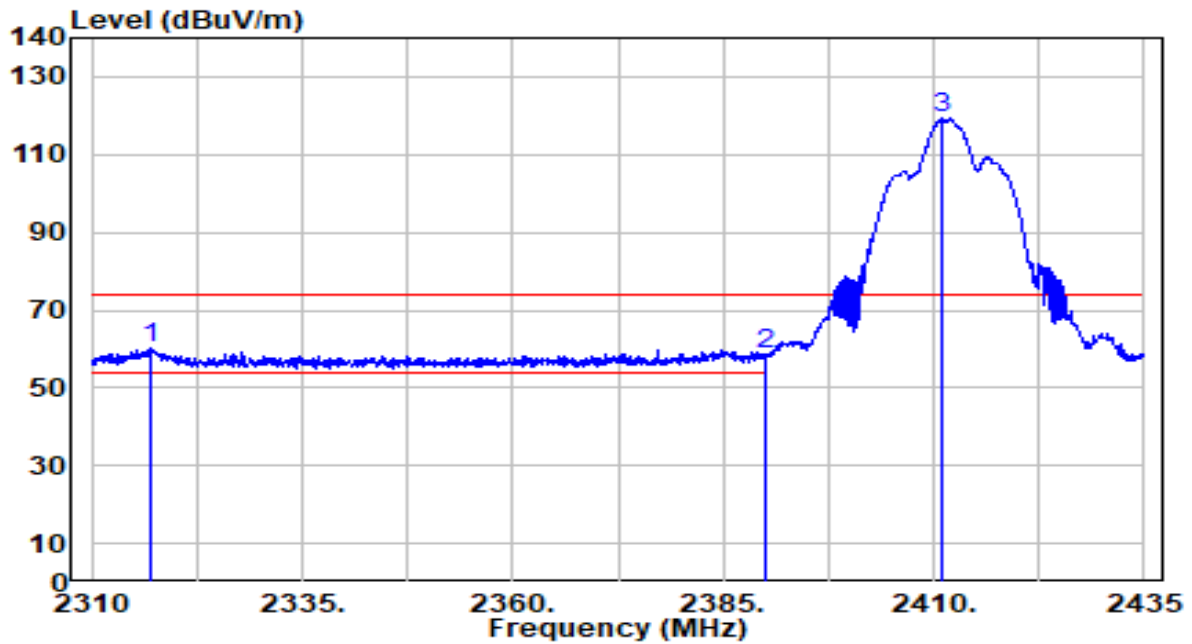

No	Frequency (MHz)	Reading (dBuV)	C.F (dB/m)	Measurement (dBuV/m)	Margin (dB)	Limit (dBuV/m)	Height (cm)	Angle (deg)	Remark (QP/PK/AV)
1	* 2316.875	29.79	30.24	60.03	-13.97	74.00	100	132	Peak
2	2390.000	28.24	30.45	58.69	-15.31	74.00	100	132	Peak
3	2411.000	88.66	30.49	119.15	N/A	N/A	100	132	Peak

Note:

1. " \*", means this data is the worst emission level.
2. C.F (Correction Factor) = Antenna Factor (dB/m) + Cable Loss (dB).
3. Measurement (dBuV/m) = Reading(dBuV) + C.F (Correction Factor).
4. The emission levels of other frequencies are very lower than the limit and not show in test report.

EUT	BE11000 Ceiling Mount Wi-Fi 7 Access Point	Date of Test	2024-05-27
Factor	DRH18-E	Temp. / Humidity	20°C /65%
Polarity	Horizontal	Site / Test Engineer	AC2 / You
Test Mode	802.11b_TX_CH 1 ANT 0+1	Test Voltage	AC 120V/60Hz

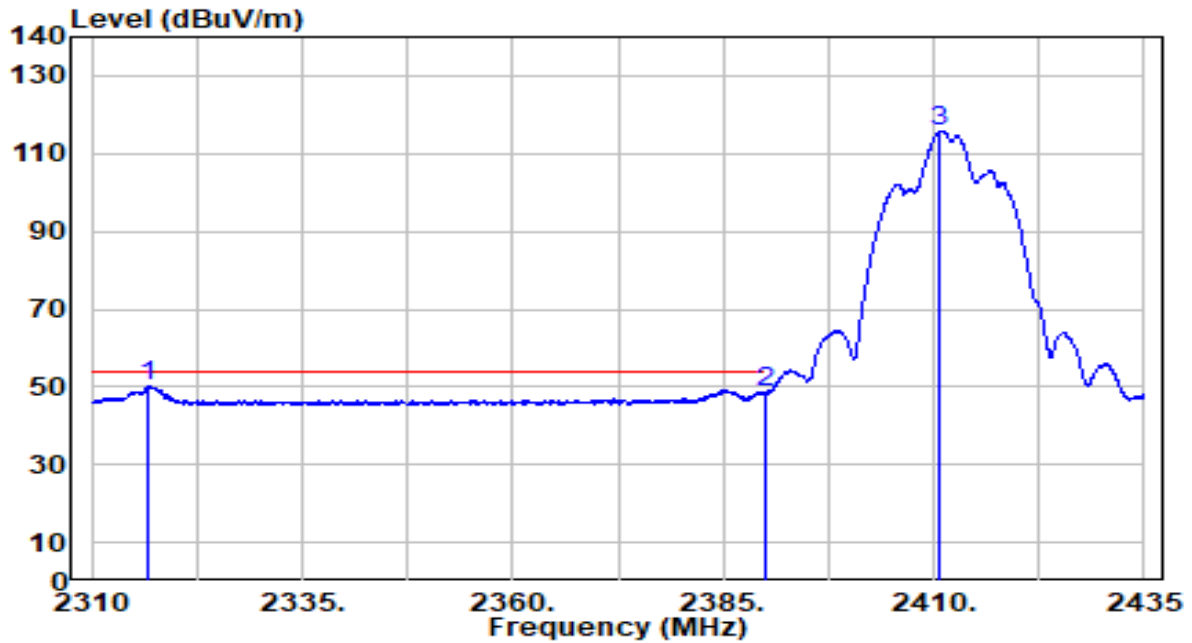

No	Frequency (MHz)	Reading (dBUV)	C.F (dB/m)	Measurement (dBUV/m)	Margin (dB)	Limit (dBUV/m)	Height (cm)	Angle (deg)	Remark (QP/PK/AV)	
1	*	2316.813	19.88	30.24	50.12	-3.88	54.00	100	132	Average
2		2390.000	18.33	30.45	48.78	-5.22	54.00	100	132	Average
3		2410.750	85.26	30.49	115.75	N/A	N/A	100	132	Average

Note:

1. " \*", means this data is the worst emission level.
2. C.F (Correction Factor) = Antenna Factor (dB/m) + Cable Loss (dB).
3. Measurement (dBUV/m) = Reading(dBUV) + C.F (Correction Factor).
4. The emission levels of other frequencies are very lower than the limit and not show in test report.

EUT	BE11000 Ceiling Mount Wi-Fi 7 Access Point	Date of Test	2024-05-27
Factor	DRH18-E	Temp. / Humidity	20°C /65%
Polarity	Vertical	Site / Test Engineer	AC2 / You
Test Mode	802.11b_TX_CH 1 ANT 0+1	Test Voltage	AC 120V/60Hz

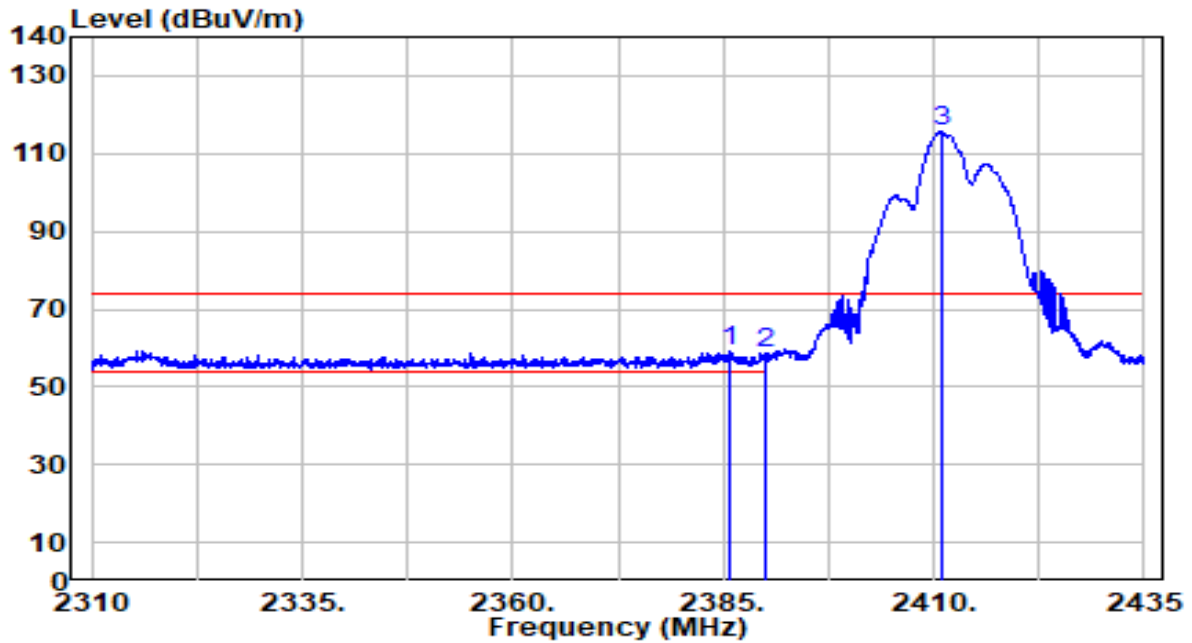

No	Frequency (MHz)	Reading (dBUV)	C.F (dB/m)	Measurement (dBUV/m)	Margin (dB)	Limit (dBUV/m)	Height (cm)	Angle (deg)	Remark (QP/PK/AV)	
1	*	2385.625	28.71	30.44	59.14	-14.86	74.00	200	167	Peak
2		2390.000	27.95	30.45	58.40	-15.60	74.00	200	167	Peak
3		2410.875	85.06	30.49	115.56	N/A	N/A	200	167	Peak

Note:

1. " \*", means this data is the worst emission level.
2. C.F (Correction Factor) = Antenna Factor (dB/m) + Cable Loss (dB).
3. Measurement (dBUV/m) = Reading(dBUV) + C.F (Correction Factor).
4. The emission levels of other frequencies are very lower than the limit and not show in test report.

EUT	BE11000 Ceiling Mount Wi-Fi 7 Access Point	Date of Test	2024-05-27
Factor	DRH18-E	Temp. / Humidity	20°C /65%
Polarity	Vertical	Site / Test Engineer	AC2 / You
Test Mode	802.11b_TX_CH 1 ANT 0+1	Test Voltage	AC 120V/60Hz

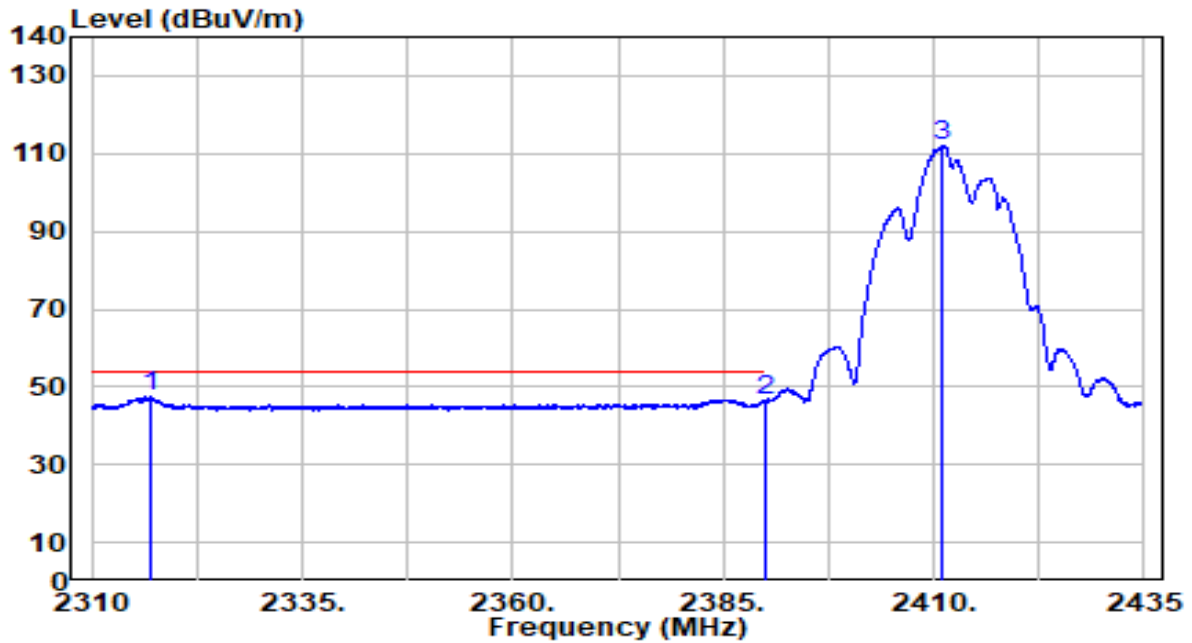

No	Frequency (MHz)	Reading (dBuV)	C.F (dB/m)	Measurement (dBuV/m)	Margin (dB)	Limit (dBuV/m)	Height (cm)	Angle (deg)	Remark (QP/PK/AV)
1	* 2317.000	17.10	30.24	47.34	-6.66	54.00	200	167	Average
2	2390.000	15.95	30.45	46.40	-7.60	54.00	200	167	Average
3	2411.125	81.37	30.49	111.86	N/A	N/A	200	167	Average

Note:

1. " \*", means this data is the worst emission level.
2. C.F (Correction Factor) = Antenna Factor (dB/m) + Cable Loss (dB).
3. Measurement (dBuV/m) = Reading(dBuV) + C.F (Correction Factor).
4. The emission levels of other frequencies are very lower than the limit and not show in test report.

EUT	BE11000 Ceiling Mount Wi-Fi 7 Access Point	Date of Test	2024-05-27
Factor	DRH18-E	Temp. / Humidity	20°C /65%
Polarity	Horizontal	Site / Test Engineer	AC2 / You
Test Mode	802.11b_TX_CH 6 ANT 0+1	Test Voltage	AC 120V/60Hz

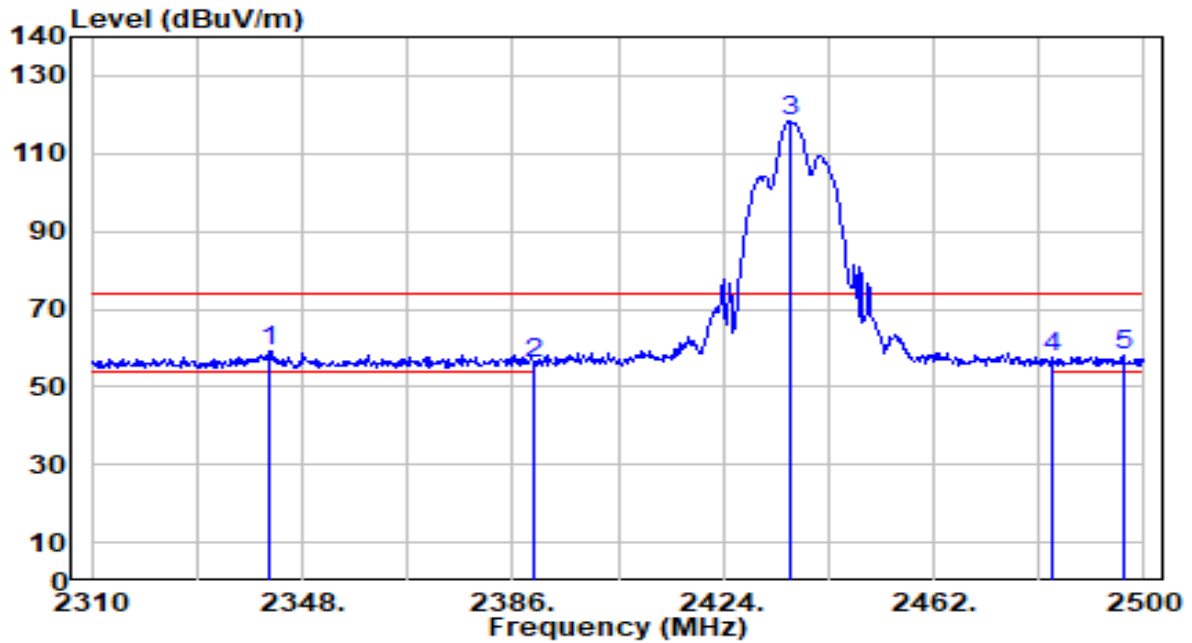

No	Frequency (MHz)	Reading (dBuV)	C.F (dB/m)	Measurement (dBuV/m)	Margin (dB)	Limit (dBuV/m)	Height (cm)	Angle (deg)	Remark (QP/PK/AV)
1	* 2342.110	28.73	30.31	59.04	-14.96	74.00	100	178	Peak
2	2390.000	25.81	30.45	56.26	-17.74	74.00	100	178	Peak
3	2435.970	87.79	30.52	118.31	N/A	N/A	100	178	Peak
4	2483.500	26.88	30.59	57.47	-16.53	74.00	100	178	Peak
5	2496.200	27.26	30.60	57.86	-16.14	74.00	100	178	Peak

Note:

- " \*", means this data is the worst emission level.
- C.F (Correction Factor) = Antenna Factor (dB/m) + Cable Loss (dB).
- Measurement (dBuV/m) = Reading(dBuV) + C.F (Correction Factor).
- The emission levels of other frequencies are very lower than the limit and not show in test report.

EUT	BE11000 Ceiling Mount Wi-Fi 7 Access Point	Date of Test	2024-05-27
Factor	DRH18-E	Temp. / Humidity	20°C /65%
Polarity	Horizontal	Site / Test Engineer	AC2 / You
Test Mode	802.11b_TX_CH 6 ANT 0+1	Test Voltage	AC 120V/60Hz

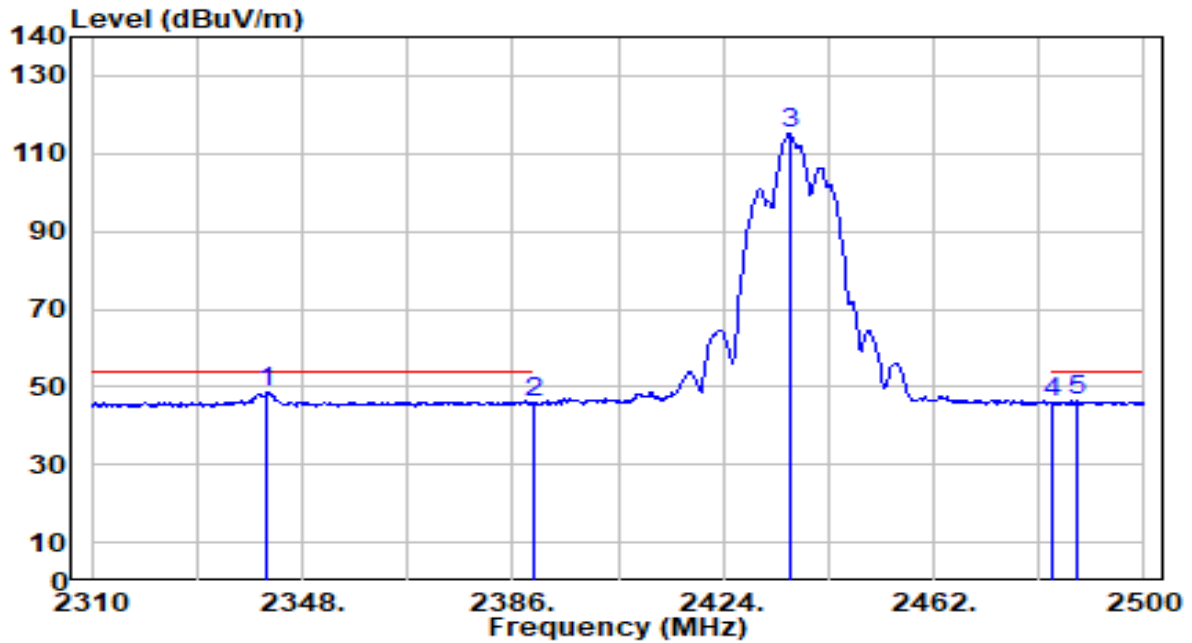

No	Frequency (MHz)	Reading (dBuV)	C.F (dB/m)	Measurement (dBuV/m)	Margin (dB)	Limit (dBuV/m)	Height (cm)	Angle (deg)	Remark (QP/PK/AV)
1	* 2341.730	18.51	30.31	48.82	-5.18	54.00	100	179	Average
2	2390.000	15.45	30.45	45.89	-8.11	54.00	100	179	Average
3	2436.160	84.80	30.52	115.33	N/A	N/A	100	179	Average
4	2483.500	15.27	30.59	45.86	-8.14	54.00	100	179	Average
5	2487.840	15.71	30.59	46.30	-7.70	54.00	100	179	Average

Note:

- " \*", means this data is the worst emission level.
- C.F (Correction Factor) = Antenna Factor (dB/m) + Cable Loss (dB).
- Measurement (dBuV/m) = Reading(dBuV) + C.F (Correction Factor).
- The emission levels of other frequencies are very lower than the limit and not show in test report.

EUT	BE11000 Ceiling Mount Wi-Fi 7 Access Point	Date of Test	2024-05-27
Factor	DRH18-E	Temp. / Humidity	20°C /65%
Polarity	Vertical	Site / Test Engineer	AC2 / You
Test Mode	802.11b_TX_CH 6 ANT 0+1	Test Voltage	AC 120V/60Hz

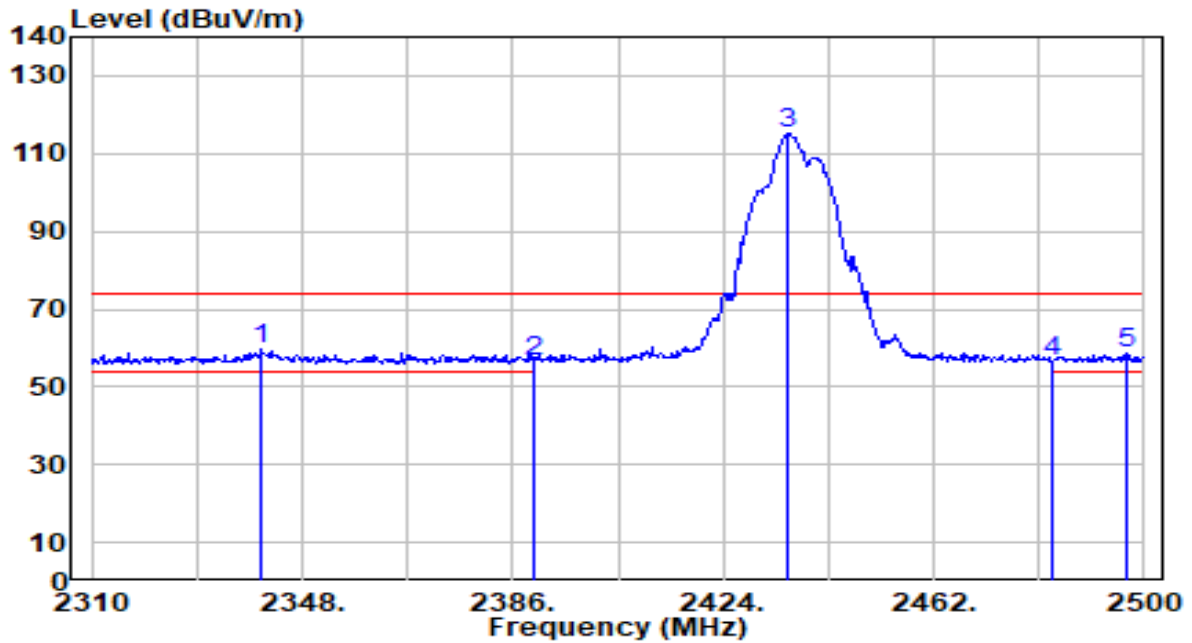

No	Frequency (MHz)	Reading (dBuV)	C.F (dB/m)	Measurement (dBuV/m)	Margin (dB)	Limit (dBuV/m)	Height (cm)	Angle (deg)	Remark (QP/PK/AV)
1	* 2340.780	29.43	30.31	59.74	-14.26	74.00	192	166	Peak
2	2390.000	26.27	30.45	56.72	-17.28	74.00	192	166	Peak
3	2435.780	84.77	30.52	115.29	N/A	N/A	192	166	Peak
4	2483.500	26.15	30.59	56.73	-17.27	74.00	192	166	Peak
5	2496.960	27.87	30.61	58.48	-15.52	74.00	192	166	Peak

Note:

- " \*", means this data is the worst emission level.
- C.F (Correction Factor) = Antenna Factor (dB/m) + Cable Loss (dB).
- Measurement (dBuV/m) = Reading(dBuV) + C.F (Correction Factor).
- The emission levels of other frequencies are very lower than the limit and not show in test report.

EUT	BE11000 Ceiling Mount Wi-Fi 7 Access Point	Date of Test	2024-05-27
Factor	DRH18-E	Temp. / Humidity	20°C /65%
Polarity	Vertical	Site / Test Engineer	AC2 / You
Test Mode	802.11b_TX_CH 6 ANT 0+1	Test Voltage	AC 120V/60Hz

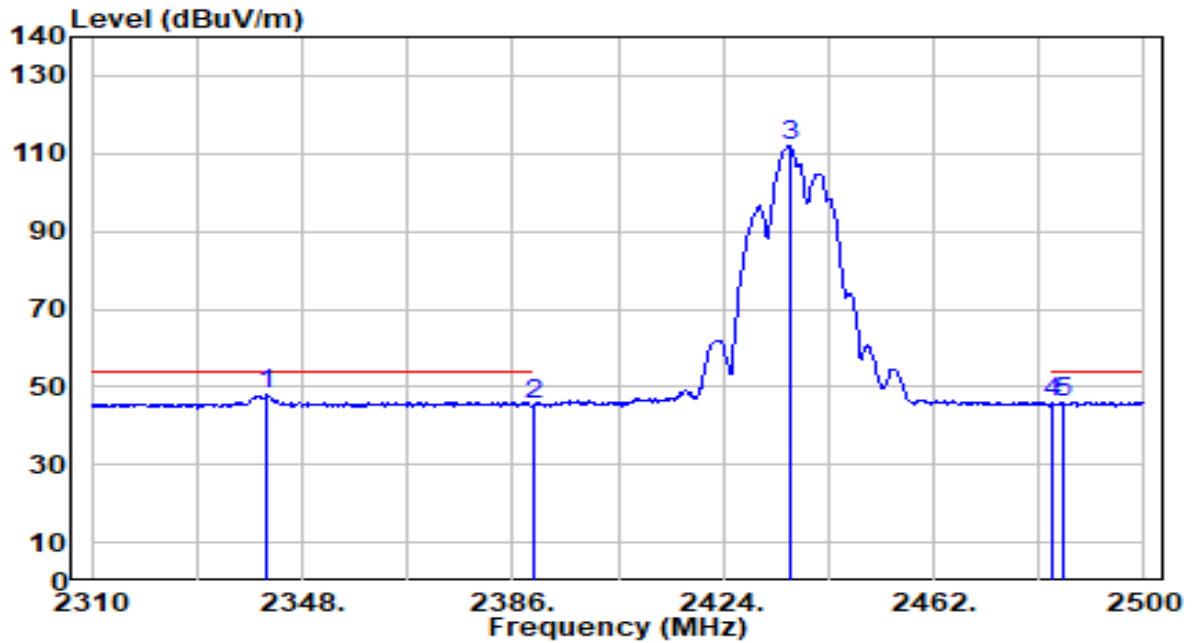

No	Frequency (MHz)	Reading (dBuV)	C.F (dB/m)	Measurement (dBuV/m)	Margin (dB)	Limit (dBuV/m)	Height (cm)	Angle (deg)	Remark (QP/PK/AV)	
1	*	2341.730	17.54	30.31	47.85	-6.15	54.00	192	166	Average
2		2390.000	14.92	30.45	45.37	-8.63	54.00	192	166	Average
3		2435.970	81.38	30.52	111.90	N/A	N/A	192	166	Average
4		2483.500	15.36	30.59	45.94	-8.06	54.00	192	166	Average
5		2485.180	15.32	30.59	45.91	-8.09	54.00	192	166	Average

Note:

- "\*", means this data is the worst emission level.
- C.F (Correction Factor) = Antenna Factor (dB/m) + Cable Loss (dB).
- Measurement (dBuV/m) = Reading(dBuV) + C.F (Correction Factor).
- The emission levels of other frequencies are very lower than the limit and not show in test report.



EUT	BE11000 Ceiling Mount Wi-Fi 7 Access Point	Date of Test	2024-05-27
Factor	DRH18-E	Temp. / Humidity	20°C /65%
Polarity	Horizontal	Site / Test Engineer	AC2 / You
Test Mode	802.11b_TX_CH 11 ANT 0+1	Test Voltage	AC 120V/60Hz

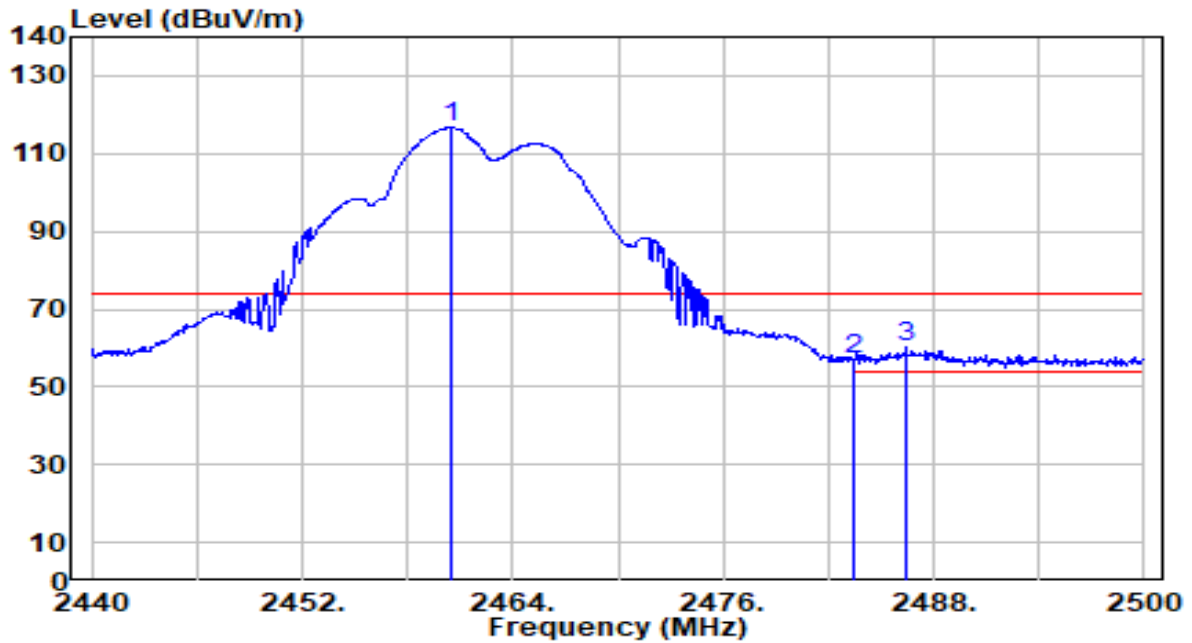

No	Frequency (MHz)	Reading (dBUV)	C.F (dB/m)	Measurement (dBUV/m)	Margin (dB)	Limit (dBUV/m)	Height (cm)	Angle (deg)	Remark (QP/PK/AV)
1	2460.460	86.12	30.56	116.68	N/A	N/A	101	246	Peak
2	2483.500	26.58	30.59	57.17	-16.83	74.00	101	246	Peak
3	* 2486.440	29.38	30.59	59.97	-14.03	74.00	101	246	Peak

Note:

1. " \*", means this data is the worst emission level.
2. C.F (Correction Factor) = Antenna Factor (dB/m) + Cable Loss (dB).
3. Measurement (dBUV/m) = Reading(dBUV) + C.F (Correction Factor).
4. The emission levels of other frequencies are very lower than the limit and not show in test report.

EUT	BE11000 Ceiling Mount Wi-Fi 7 Access Point	Date of Test	2024-05-27
Factor	DRH18-E	Temp. / Humidity	20°C /65%
Polarity	Horizontal	Site / Test Engineer	AC2 / You
Test Mode	802.11b_TX_CH 11 ANT 0+1	Test Voltage	AC 120V/60Hz

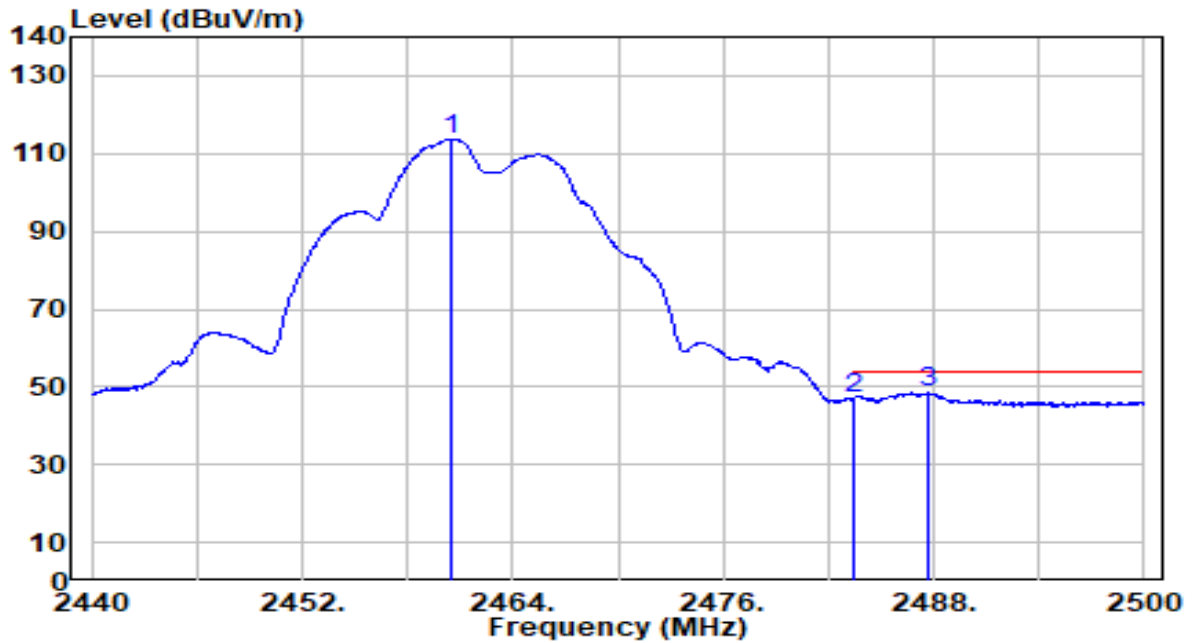

No	Frequency (MHz)	Reading (dBuV)	C.F (dB/m)	Measurement (dBuV/m)	Margin (dB)	Limit (dBuV/m)	Height (cm)	Angle (deg)	Remark (QP/PK/AV)
1	2460.460	83.08	30.56	113.64	N/A	N/A	101	246	Average
2	2483.500	16.19	30.59	46.77	-7.23	54.00	101	246	Average
3	* 2487.700	17.95	30.59	48.54	-5.46	54.00	101	246	Average

Note:

1. " \*", means this data is the worst emission level.
2. C.F (Correction Factor) = Antenna Factor (dB/m) + Cable Loss (dB).
3. Measurement (dBuV/m) = Reading(dBuV) + C.F (Correction Factor).
4. The emission levels of other frequencies are very lower than the limit and not show in test report.

EUT	BE11000 Ceiling Mount Wi-Fi 7 Access Point	Date of Test	2024-05-27
Factor	DRH18-E	Temp. / Humidity	20°C /65%
Polarity	Vertical	Site / Test Engineer	AC2 / You
Test Mode	802.11b_TX_CH 11 ANT 0+1	Test Voltage	AC 120V/60Hz

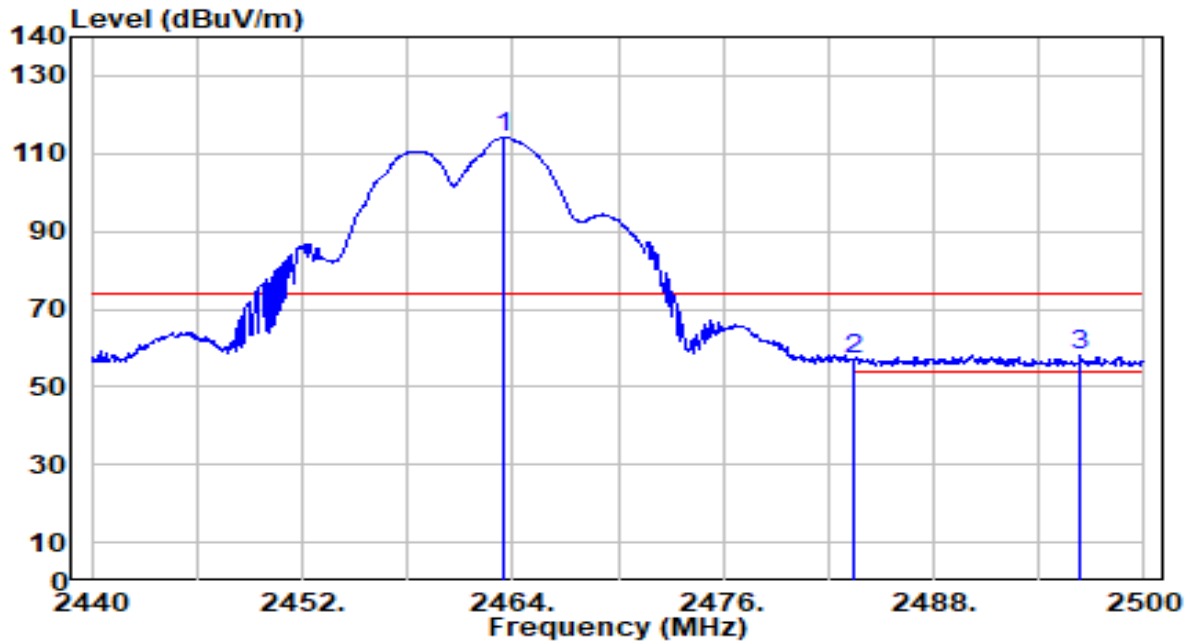

No	Frequency (MHz)	Reading (dBUV)	C.F (dB/m)	Measurement (dBUV/m)	Margin (dB)	Limit (dBUV/m)	Height (cm)	Angle (deg)	Remark (QP/PK/AV)
1	2463.520	83.51	30.56	114.07	N/A	N/A	200	167	Peak
2	2483.500	26.41	30.59	57.00	-17.00	74.00	200	167	Peak
3	* 2496.340	27.47	30.61	58.08	-15.92	74.00	200	167	Peak

Note:

1. " \*", means this data is the worst emission level.
2. C.F (Correction Factor) = Antenna Factor (dB/m) + Cable Loss (dB).
3. Measurement (dBUV/m) = Reading(dBUV) + C.F (Correction Factor).
4. The emission levels of other frequencies are very lower than the limit and not show in test report.

EUT	BE11000 Ceiling Mount Wi-Fi 7 Access Point	Date of Test	2024-05-27
Factor	DRH18-E	Temp. / Humidity	20°C /65%
Polarity	Vertical	Site / Test Engineer	AC2 / You
Test Mode	802.11b_TX_CH 11 ANT 0+1	Test Voltage	AC 120V/60Hz

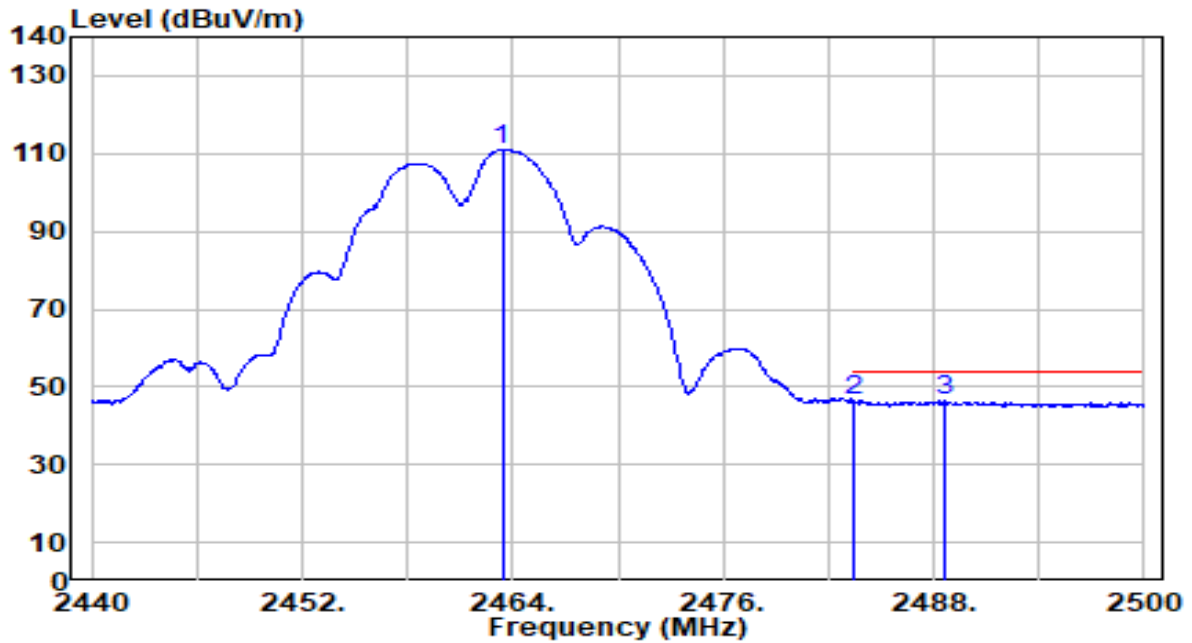

No	Frequency (MHz)	Reading (dBUV)	C.F (dB/m)	Measurement (dBUV/m)	Margin (dB)	Limit (dBUV/m)	Height (cm)	Angle (deg)	Remark (QP/PK/AV)
1	2463.400	80.40	30.56	110.96	N/A	N/A	200	167	Average
2	* 2483.500	15.81	30.59	46.40	-7.60	54.00	200	167	Average
3	2488.600	15.65	30.59	46.25	-7.75	54.00	200	167	Average

Note:

1. " \*", means this data is the worst emission level.
2. C.F (Correction Factor) = Antenna Factor (dB/m) + Cable Loss (dB).
3. Measurement (dBUV/m) = Reading(dBUV) + C.F (Correction Factor).
4. The emission levels of other frequencies are very lower than the limit and not show in test report.

EUT	BE11000 Ceiling Mount Wi-Fi 7 Access Point	Date of Test	2024-05-27
Factor	DRH18-E	Temp. / Humidity	20°C /65%
Polarity	Horizontal	Site / Test Engineer	AC2 / You
Test Mode	802.11g_TX_CH 1 ANT 0+1	Test Voltage	AC 120V/60Hz

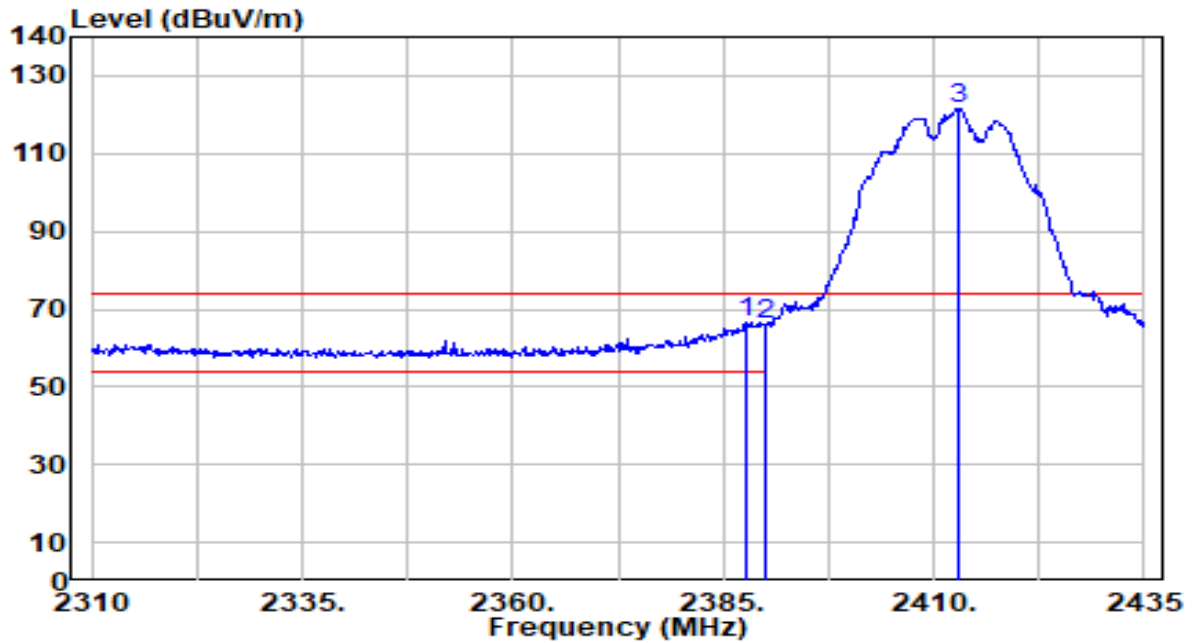

No	Frequency (MHz)	Reading (dBUV)	C.F (dB/m)	Measurement (dBUV/m)	Margin (dB)	Limit (dBUV/m)	Height (cm)	Angle (deg)	Remark (QP/PK/AV)	
1	*	2387.625	36.02	30.44	66.46	-7.54	74.00	100	127	Peak
2		2390.000	35.41	30.45	65.86	-8.14	74.00	100	127	Peak
3		2412.875	90.93	30.49	121.43	N/A	N/A	100	127	Peak

Note:

1. " \*", means this data is the worst emission level.
2. C.F (Correction Factor) = Antenna Factor (dB/m) + Cable Loss (dB).
3. Measurement (dBUV/m) = Reading(dBUV) + C.F (Correction Factor).
4. The emission levels of other frequencies are very lower than the limit and not show in test report.

EUT	BE11000 Ceiling Mount Wi-Fi 7 Access Point	Date of Test	2024-05-27
Factor	DRH18-E	Temp. / Humidity	20°C /65%
Polarity	Horizontal	Site / Test Engineer	AC2 / You
Test Mode	802.11g_TX_CH 1 ANT 0+1	Test Voltage	AC 120V/60Hz

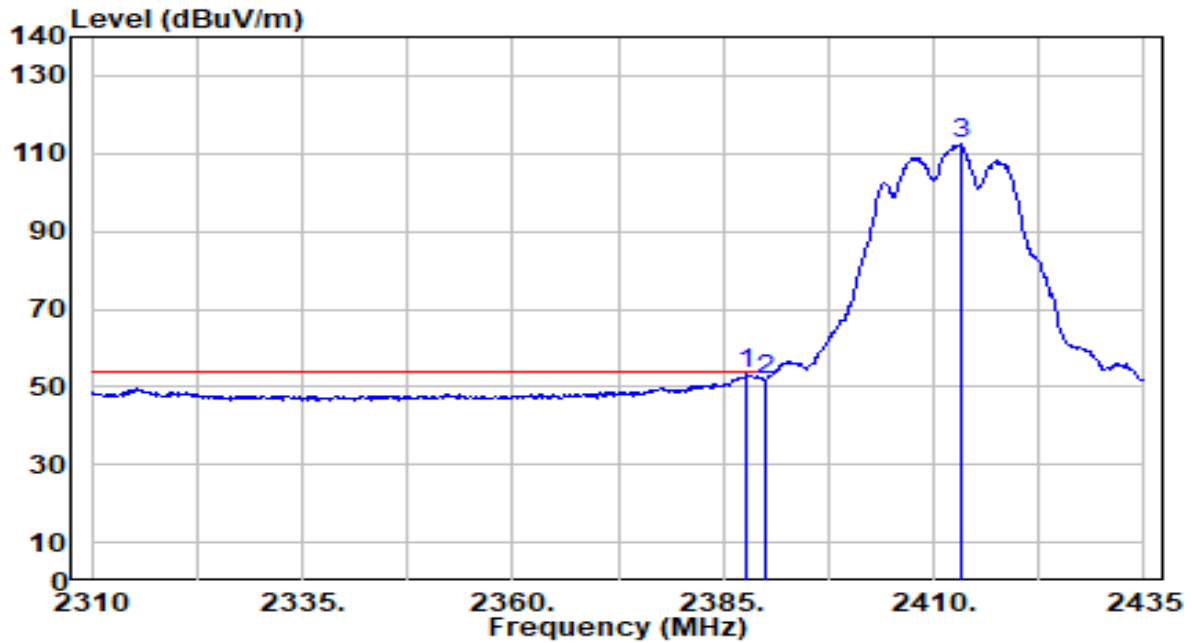

No	Frequency (MHz)	Reading (dBuV)	C.F (dB/m)	Measurement (dBuV/m)	Margin (dB)	Limit (dBuV/m)	Height (cm)	Angle (deg)	Remark (QP/PK/AV)	
1	*	2387.875	22.84	30.44	53.28	-0.72	54.00	100	127	Average
2		2390.000	21.44	30.45	51.89	-2.11	54.00	100	127	Average
3		2413.125	81.83	30.49	112.33	N/A	N/A	100	127	Average

Note:

1. " \*", means this data is the worst emission level.
2. C.F (Correction Factor) = Antenna Factor (dB/m) + Cable Loss (dB).
3. Measurement (dBuV/m) = Reading(dBuV) + C.F (Correction Factor).
4. The emission levels of other frequencies are very lower than the limit and not show in test report.

EUT	BE11000 Ceiling Mount Wi-Fi 7 Access Point	Date of Test	2024-05-27
Factor	DRH18-E	Temp. / Humidity	20°C /65%
Polarity	Vertical	Site / Test Engineer	AC2 / You
Test Mode	802.11g_TX_CH 1 ANT 0+1	Test Voltage	AC 120V/60Hz

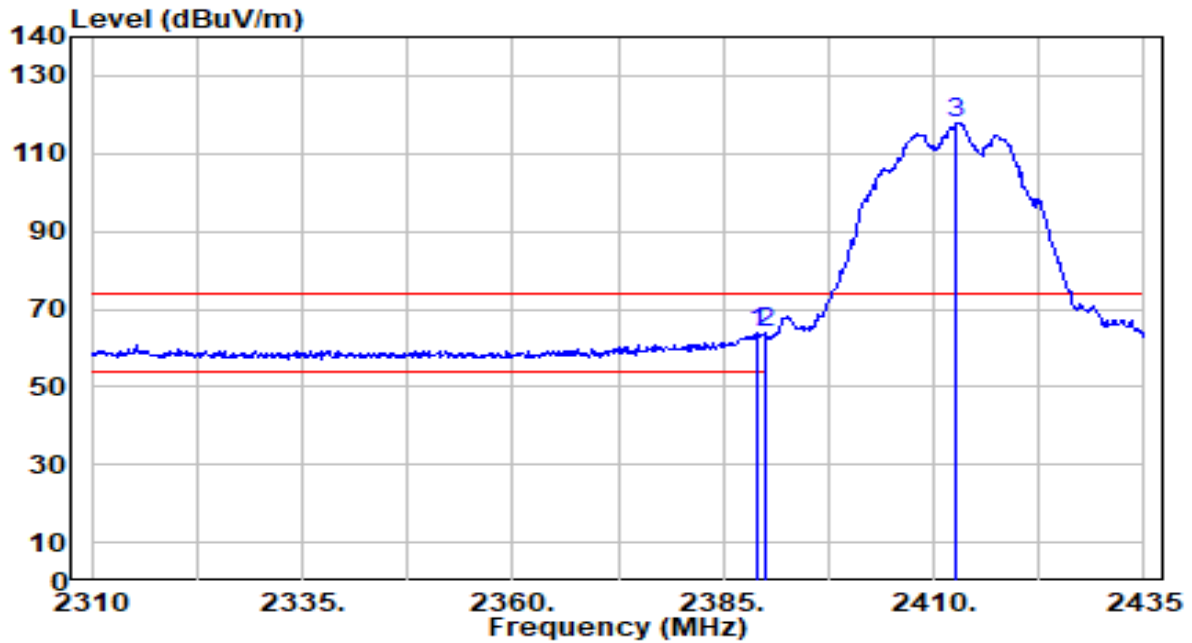

No	Frequency (MHz)	Reading (dBUV)	C.F (dB/m)	Measurement (dBUV/m)	Margin (dB)	Limit (dBUV/m)	Height (cm)	Angle (deg)	Remark (QP/PK/AV)
1	2389.000	33.31	30.44	63.75	-10.25	74.00	200	167	Peak
2	* 2390.000	33.31	30.45	63.76	-10.24	74.00	200	167	Peak
3	2412.750	87.47	30.49	117.97	N/A	N/A	200	167	Peak

Note:

1. " \*", means this data is the worst emission level.
2. C.F (Correction Factor) = Antenna Factor (dB/m) + Cable Loss (dB).
3. Measurement (dBUV/m) = Reading(dBUV) + C.F (Correction Factor).
4. The emission levels of other frequencies are very lower than the limit and not show in test report.

EUT	BE11000 Ceiling Mount Wi-Fi 7 Access Point	Date of Test	2024-05-27
Factor	DRH18-E	Temp. / Humidity	20°C /65%
Polarity	Vertical	Site / Test Engineer	AC2 / You
Test Mode	802.11g_TX_CH 1 ANT 0+1	Test Voltage	AC 120V/60Hz

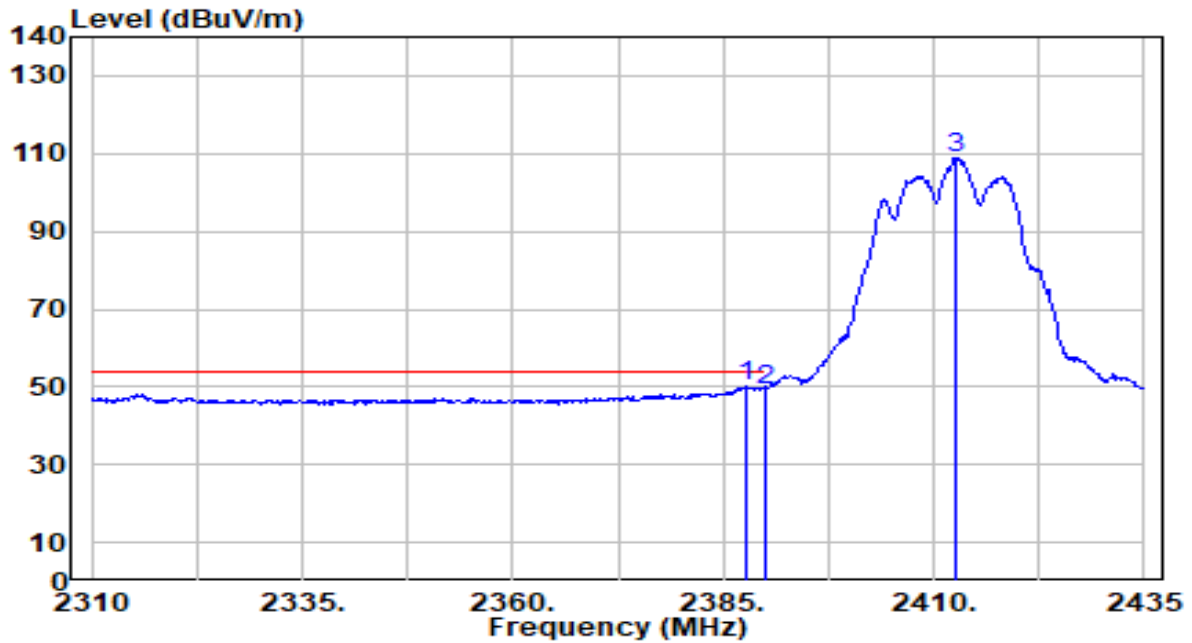

No	Frequency (MHz)	Reading (dBUV)	C.F (dB/m)	Measurement (dBUV/m)	Margin (dB)	Limit (dBUV/m)	Height (cm)	Angle (deg)	Remark (QP/PK/AV)	
1	*	2387.875	19.71	30.44	50.15	-3.85	54.00	200	167	Average
2		2390.000	18.93	30.45	49.38	-4.62	54.00	200	167	Average
3		2412.750	78.32	30.49	108.81	N/A	N/A	200	167	Average

Note:

1. "\*" means this data is the worst emission level.
2. C.F (Correction Factor) = Antenna Factor (dB/m) + Cable Loss (dB).
3. Measurement (dBUV/m) = Reading(dBUV) + C.F (Correction Factor).
4. The emission levels of other frequencies are very lower than the limit and not show in test report.



EUT	BE11000 Ceiling Mount Wi-Fi 7 Access Point	Date of Test	2024-05-27
Factor	DRH18-E	Temp. / Humidity	20°C /65%
Polarity	Horizontal	Site / Test Engineer	AC2 / You
Test Mode	802.11g_TX_CH 6 ANT 0+1	Test Voltage	AC 120V/60Hz

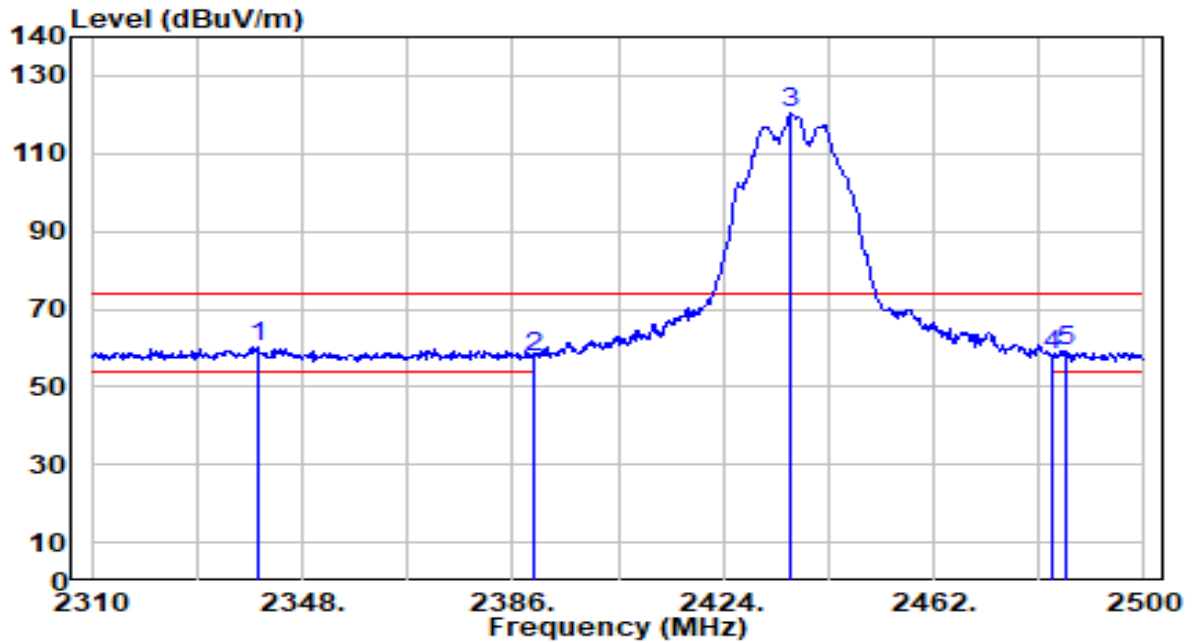

No	Frequency (MHz)	Reading (dBuV)	C.F (dB/m)	Measurement (dBuV/m)	Margin (dB)	Limit (dBuV/m)	Height (cm)	Angle (deg)	Remark (QP/PK/AV)
1	* 2339.830	30.01	30.31	60.32	-13.68	74.00	100	188	Peak
2	2390.000	27.21	30.45	57.65	-16.35	74.00	100	188	Peak
3	2436.350	89.73	30.52	120.26	N/A	N/A	100	188	Peak
4	2483.500	27.39	30.59	57.98	-16.02	74.00	100	188	Peak
5	2486.130	28.64	30.59	59.23	-14.77	74.00	100	188	Peak

Note:

- " \*", means this data is the worst emission level.
- C.F (Correction Factor) = Antenna Factor (dB/m) + Cable Loss (dB).
- Measurement (dBuV/m) = Reading(dBuV) + C.F (Correction Factor).
- The emission levels of other frequencies are very lower than the limit and not show in test report.

EUT	BE11000 Ceiling Mount Wi-Fi 7 Access Point	Date of Test	2024-05-27
Factor	DRH18-E	Temp. / Humidity	20°C /65%
Polarity	Horizontal	Site / Test Engineer	AC2 / You
Test Mode	802.11g_TX_CH 6 ANT 0+1	Test Voltage	AC 120V/60Hz

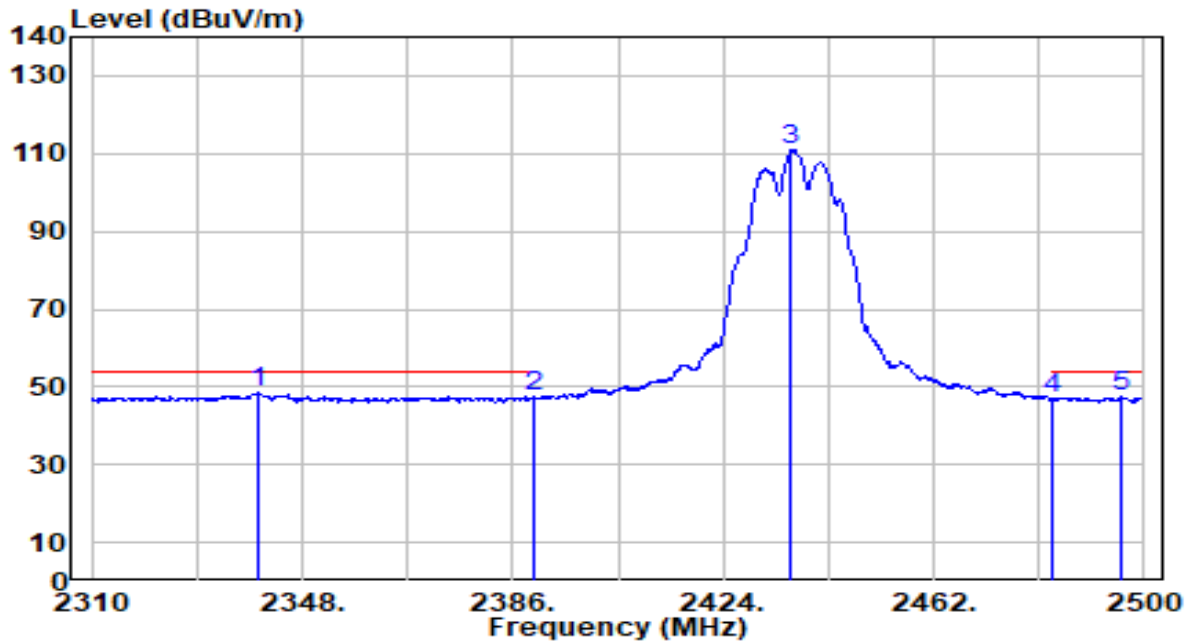

No	Frequency (MHz)	Reading (dBuV)	C.F (dB/m)	Measurement (dBuV/m)	Margin (dB)	Limit (dBuV/m)	Height (cm)	Angle (deg)	Remark (QP/PK/AV)
1	* 2340.020	18.31	30.31	48.62	-5.38	54.00	100	188	Average
2	2390.000	16.84	30.45	47.29	-6.71	54.00	100	188	Average
3	2436.350	80.48	30.52	111.01	N/A	N/A	100	188	Average
4	2483.500	16.42	30.59	47.01	-6.99	54.00	100	188	Average
5	2496.010	16.75	30.60	47.35	-6.65	54.00	100	188	Average

Note:

- " \*", means this data is the worst emission level.
- C.F (Correction Factor) = Antenna Factor (dB/m) + Cable Loss (dB).
- Measurement (dBuV/m) = Reading(dBuV) + C.F (Correction Factor).
- The emission levels of other frequencies are very lower than the limit and not show in test report.

EUT	BE11000 Ceiling Mount Wi-Fi 7 Access Point	Date of Test	2024-05-27
Factor	DRH18-E	Temp. / Humidity	20°C /65%
Polarity	Vertical	Site / Test Engineer	AC2 / You
Test Mode	802.11g_TX_CH 6 ANT 0+1	Test Voltage	AC 120V/60Hz

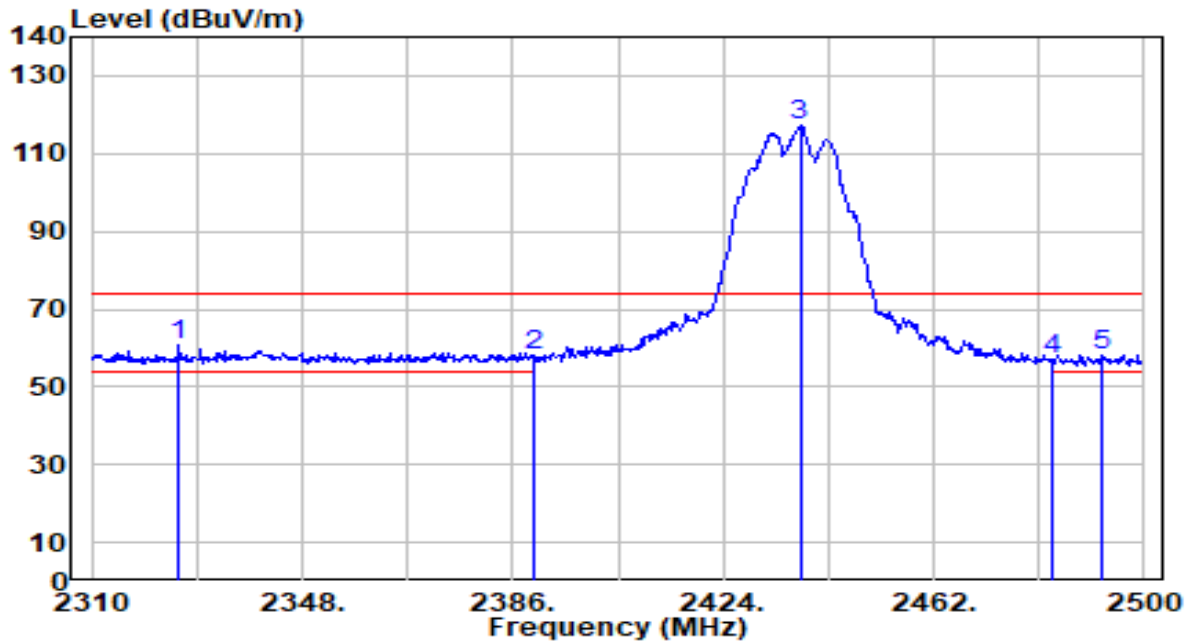

No	Frequency (MHz)	Reading (dBuV)	C.F (dB/m)	Measurement (dBuV/m)	Margin (dB)	Limit (dBuV/m)	Height (cm)	Angle (deg)	Remark (QP/PK/AV)
1	* 2325.770	30.31	30.27	60.57	-13.43	74.00	200	168	Peak
2	2390.000	27.68	30.45	58.13	-15.87	74.00	200	168	Peak
3	2437.870	86.54	30.53	117.07	N/A	N/A	200	168	Peak
4	2483.500	26.46	30.59	57.05	-16.95	74.00	200	168	Peak
5	2492.590	27.74	30.60	58.34	-15.66	74.00	200	168	Peak

Note:

- "\*" means this data is the worst emission level.
- C.F (Correction Factor) = Antenna Factor (dB/m) + Cable Loss (dB).
- Measurement (dBuV/m) = Reading(dBuV) + C.F (Correction Factor).
- The emission levels of other frequencies are very lower than the limit and not show in test report.

EUT	BE11000 Ceiling Mount Wi-Fi 7 Access Point	Date of Test	2024-05-27
Factor	DRH18-E	Temp. / Humidity	20°C /65%
Polarity	Vertical	Site / Test Engineer	AC2 / You
Test Mode	802.11g_TX_CH 6 ANT 0+1	Test Voltage	AC 120V/60Hz

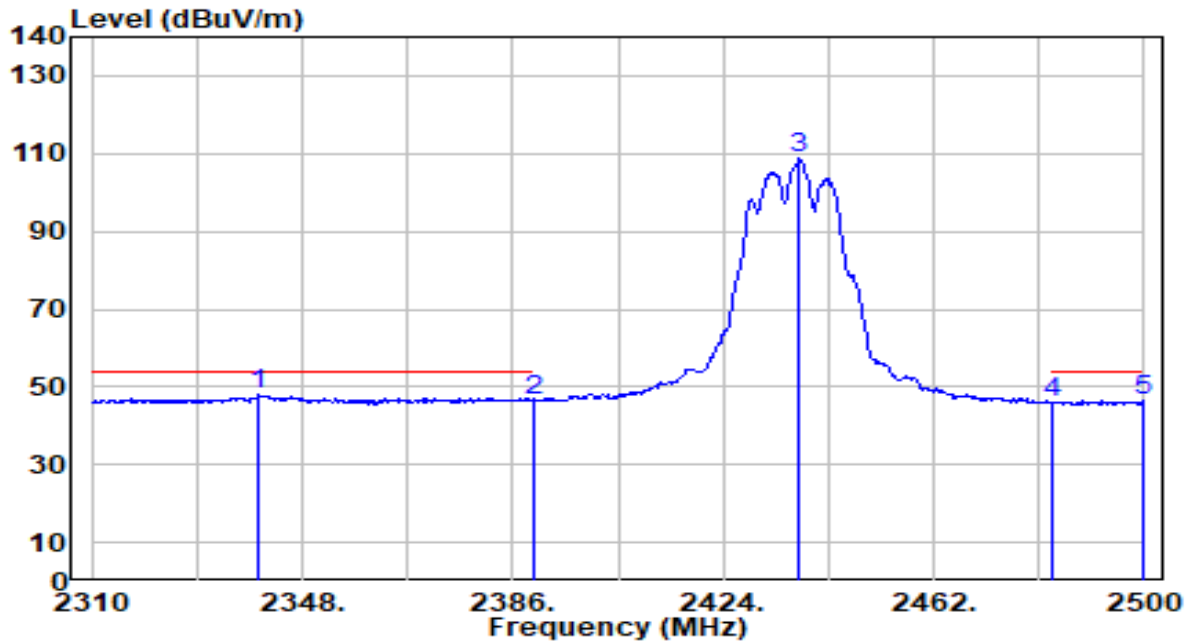

No	Frequency (MHz)	Reading (dBuV)	C.F (dB/m)	Measurement (dBuV/m)	Margin (dB)	Limit (dBuV/m)	Height (cm)	Angle (deg)	Remark (QP/PK/AV)
1	* 2340.210	17.55	30.31	47.85	-6.15	54.00	200	168	Average
2	2390.000	15.95	30.45	46.40	-7.60	54.00	200	168	Average
3	2437.680	78.25	30.53	108.78	N/A	N/A	200	168	Average
4	2483.500	15.59	30.59	46.18	-7.82	54.00	200	168	Average
5	2499.810	15.77	30.61	46.38	-7.62	54.00	200	168	Average

Note:

- " \*", means this data is the worst emission level.
- C.F (Correction Factor) = Antenna Factor (dB/m) + Cable Loss (dB).
- Measurement (dBuV/m) = Reading(dBuV) + C.F (Correction Factor).
- The emission levels of other frequencies are very lower than the limit and not show in test report.

EUT	BE11000 Ceiling Mount Wi-Fi 7 Access Point	Date of Test	2024-05-27
Factor	DRH18-E	Temp. / Humidity	20°C /65%
Polarity	Horizontal	Site / Test Engineer	AC2 / You
Test Mode	802.11g_TX_CH 11 ANT 0+1	Test Voltage	AC 120V/60Hz

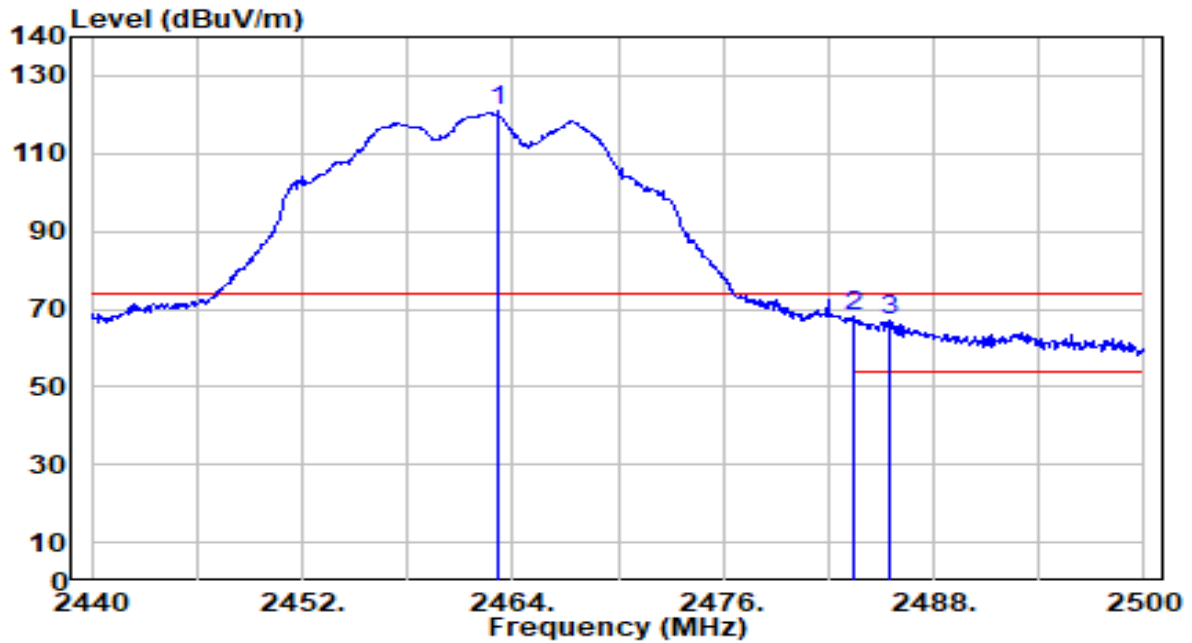

No	Frequency (MHz)	Reading (dBUV)	C.F (dB/m)	Measurement (dBUV/m)	Margin (dB)	Limit (dBUV/m)	Height (cm)	Angle (deg)	Remark (QP/PK/AV)
1	2463.160	90.20	30.56	120.76	N/A	N/A	100	182	Peak
2	* 2483.500	37.32	30.59	67.91	-6.09	74.00	100	182	Peak
3	2485.420	36.32	30.59	66.91	-7.09	74.00	100	182	Peak

Note:

1. " \*", means this data is the worst emission level.
2. C.F (Correction Factor) = Antenna Factor (dB/m) + Cable Loss (dB).
3. Measurement (dBUV/m) = Reading(dBUV) + C.F (Correction Factor).
4. The emission levels of other frequencies are very lower than the limit and not show in test report.

EUT	BE11000 Ceiling Mount Wi-Fi 7 Access Point	Date of Test	2024-05-27
Factor	DRH18-E	Temp. / Humidity	20°C /65%
Polarity	Horizontal	Site / Test Engineer	AC2 / You
Test Mode	802.11g_TX_CH 11 ANT 0+1	Test Voltage	AC 120V/60Hz

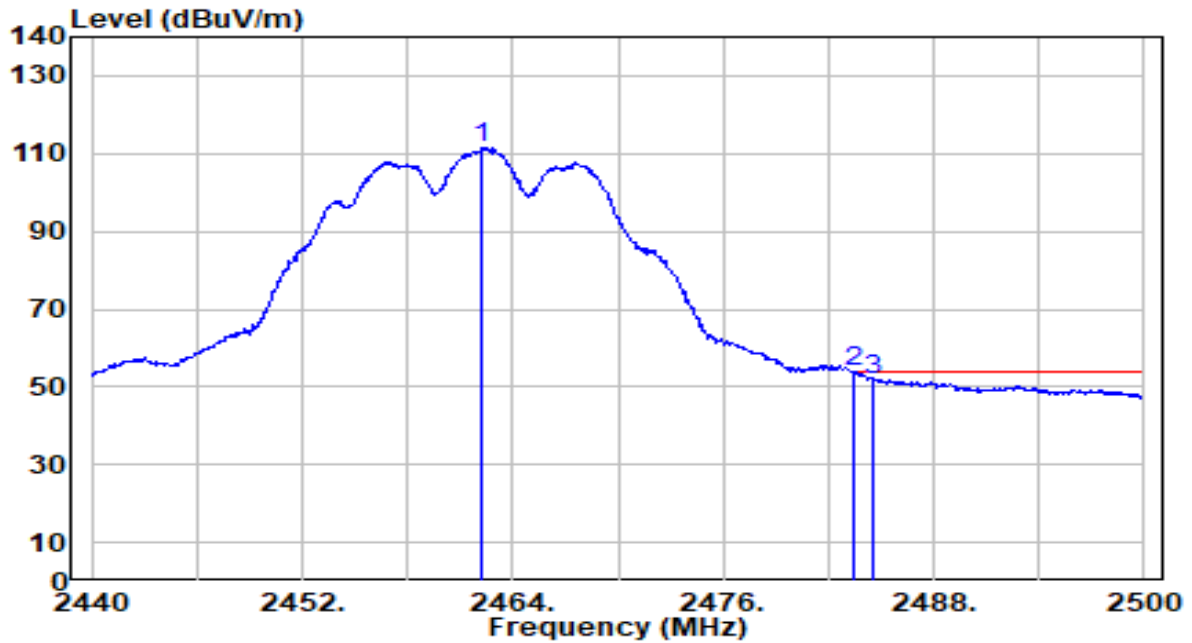

No	Frequency (MHz)	Reading (dBUV)	C.F (dB/m)	Measurement (dBUV/m)	Margin (dB)	Limit (dBUV/m)	Height (cm)	Angle (deg)	Remark (QP/PK/AV)
1	2462.260	80.85	30.56	111.41	N/A	N/A	100	182	Average
2	* 2483.500	23.20	30.59	53.79	-0.21	54.00	100	182	Average
3	2484.580	21.23	30.59	51.82	-2.18	54.00	100	182	Average

Note:

1. " \*", means this data is the worst emission level.
2. C.F (Correction Factor) = Antenna Factor (dB/m) + Cable Loss (dB).
3. Measurement (dBUV/m) = Reading(dBUV) + C.F (Correction Factor).
4. The emission levels of other frequencies are very lower than the limit and not show in test report.

EUT	BE11000 Ceiling Mount Wi-Fi 7 Access Point	Date of Test	2024-05-27
Factor	DRH18-E	Temp. / Humidity	20°C /65%
Polarity	Vertical	Site / Test Engineer	AC2 / You
Test Mode	802.11g_TX_CH 11 ANT 0+1	Test Voltage	AC 120V/60Hz

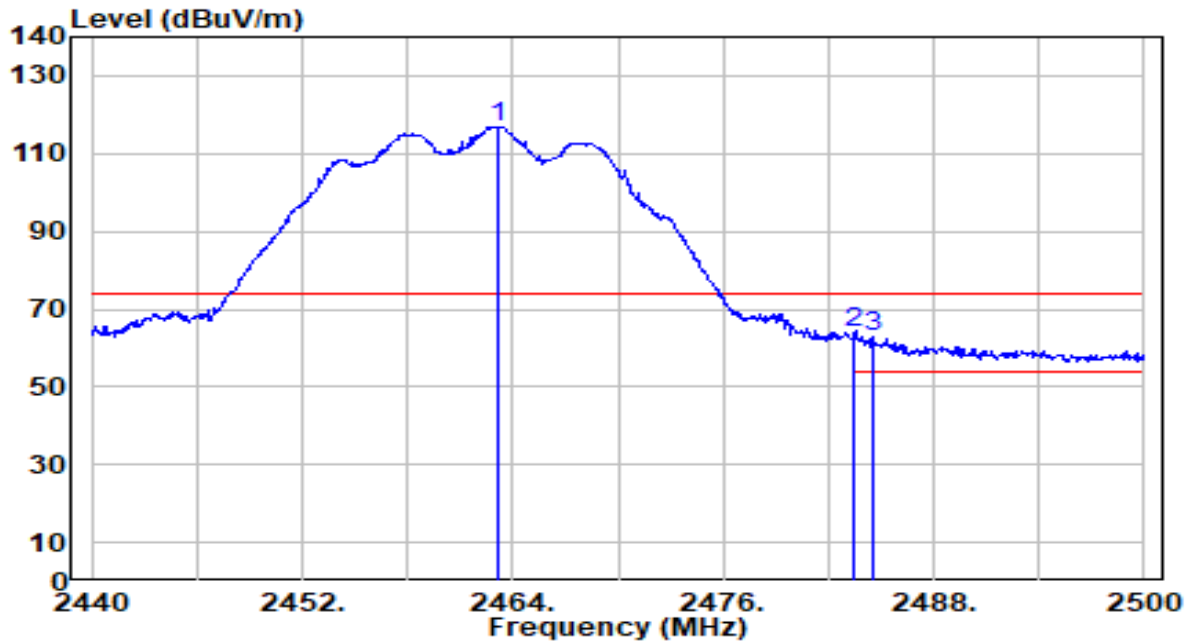

No	Frequency (MHz)	Reading (dBUV)	C.F (dB/m)	Measurement (dBUV/m)	Margin (dB)	Limit (dBUV/m)	Height (cm)	Angle (deg)	Remark (QP/PK/AV)
1	2463.100	86.40	30.56	116.96	N/A	N/A	200	163	Peak
2	* 2483.500	33.48	30.59	64.06	-9.94	74.00	200	163	Peak
3	2484.580	32.22	30.59	62.81	-11.19	74.00	200	163	Peak

Note:

1. " \*", means this data is the worst emission level.
2. C.F (Correction Factor) = Antenna Factor (dB/m) + Cable Loss (dB).
3. Measurement (dBUV/m) = Reading(dBUV) + C.F (Correction Factor).
4. The emission levels of other frequencies are very lower than the limit and not show in test report.

EUT	BE11000 Ceiling Mount Wi-Fi 7 Access Point	Date of Test	2024-05-27
Factor	DRH18-E	Temp. / Humidity	20°C /65%
Polarity	Vertical	Site / Test Engineer	AC2 / You
Test Mode	802.11g_TX_CH 11 ANT 0+1	Test Voltage	AC 120V/60Hz

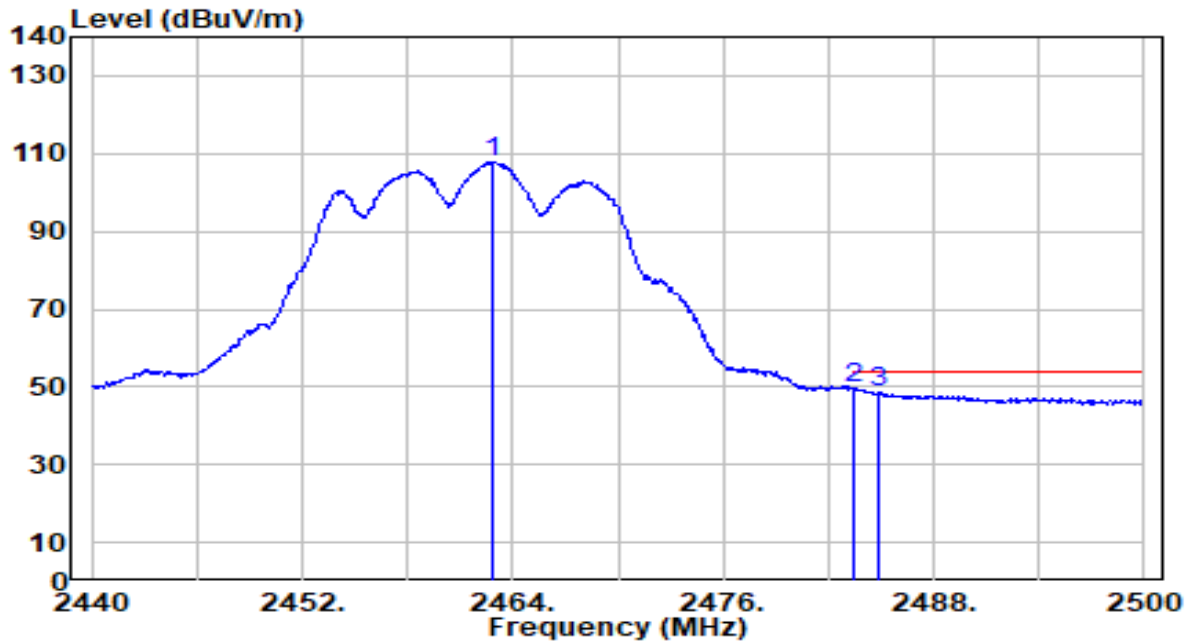

No	Frequency (MHz)	Reading (dBuV)	C.F (dB/m)	Measurement (dBuV/m)	Margin (dB)	Limit (dBuV/m)	Height (cm)	Angle (deg)	Remark (QP/PK/AV)
1	2462.920	77.36	30.56	107.92	N/A	N/A	200	163	Average
2	* 2483.500	18.93	30.59	49.51	-4.49	54.00	200	163	Average
3	2484.880	18.05	30.59	48.64	-5.36	54.00	200	163	Average

Note:

1. " \*", means this data is the worst emission level.
2. C.F (Correction Factor) = Antenna Factor (dB/m) + Cable Loss (dB).
3. Measurement (dBuV/m) = Reading(dBuV) + C.F (Correction Factor).
4. The emission levels of other frequencies are very lower than the limit and not show in test report.



EUT	BE11000 Ceiling Mount Wi-Fi 7 Access Point	Date of Test	2024-05-27
Factor	DRH18-E	Temp. / Humidity	20°C /65%
Polarity	Horizontal	Site / Test Engineer	AC2 / You
Test Mode	802.11n-20MHz_TX_CH 1 ANT 0+1	Test Voltage	AC 120V/60Hz

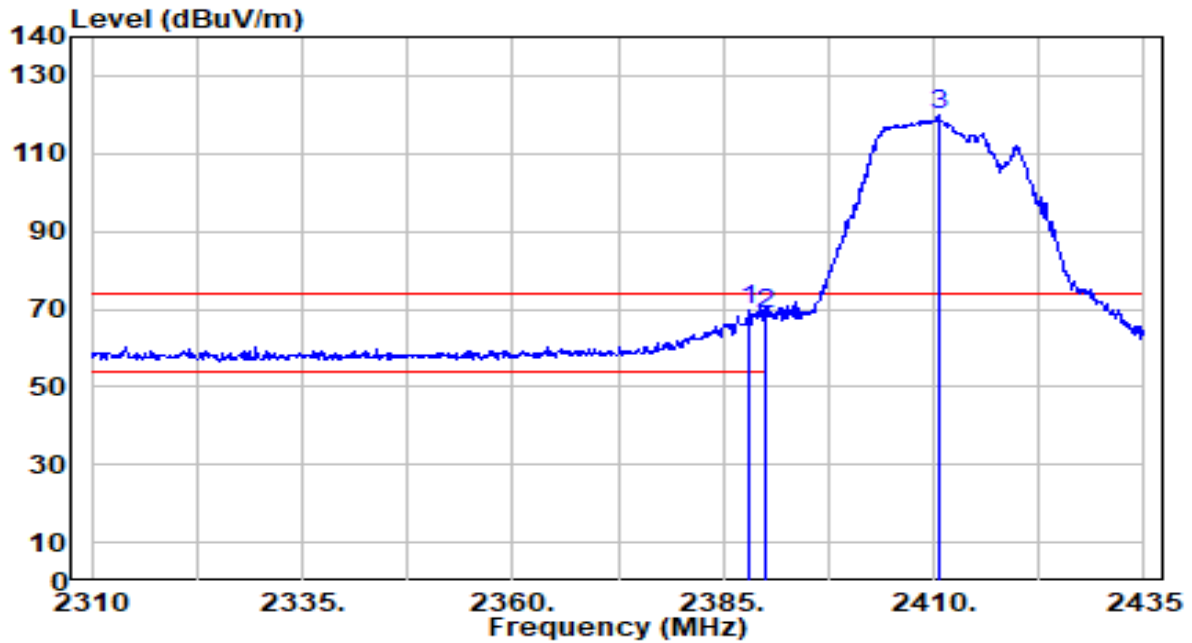

No	Frequency (MHz)	Reading (dBuV)	C.F (dB/m)	Measurement (dBuV/m)	Margin (dB)	Limit (dBuV/m)	Height (cm)	Angle (deg)	Remark (QP/PK/AV)	
1	*	2388.125	39.04	30.44	69.48	-4.52	74.00	100	110	Peak
2		2390.000	38.22	30.45	68.66	-5.34	74.00	100	110	Peak
3		2410.625	89.23	30.49	119.72	N/A	N/A	100	110	Peak

Note:

1. " \*", means this data is the worst emission level.
2. C.F (Correction Factor) = Antenna Factor (dB/m) + Cable Loss (dB).
3. Measurement (dBuV/m) = Reading(dBuV) + C.F (Correction Factor).
4. The emission levels of other frequencies are very lower than the limit and not show in test report.

EUT	BE11000 Ceiling Mount Wi-Fi 7 Access Point	Date of Test	2024-05-27
Factor	DRH18-E	Temp. / Humidity	20°C /65%
Polarity	Horizontal	Site / Test Engineer	AC2 / You
Test Mode	802.11n-20MHz_TX_CH 1 ANT 0+1	Test Voltage	AC 120V/60Hz

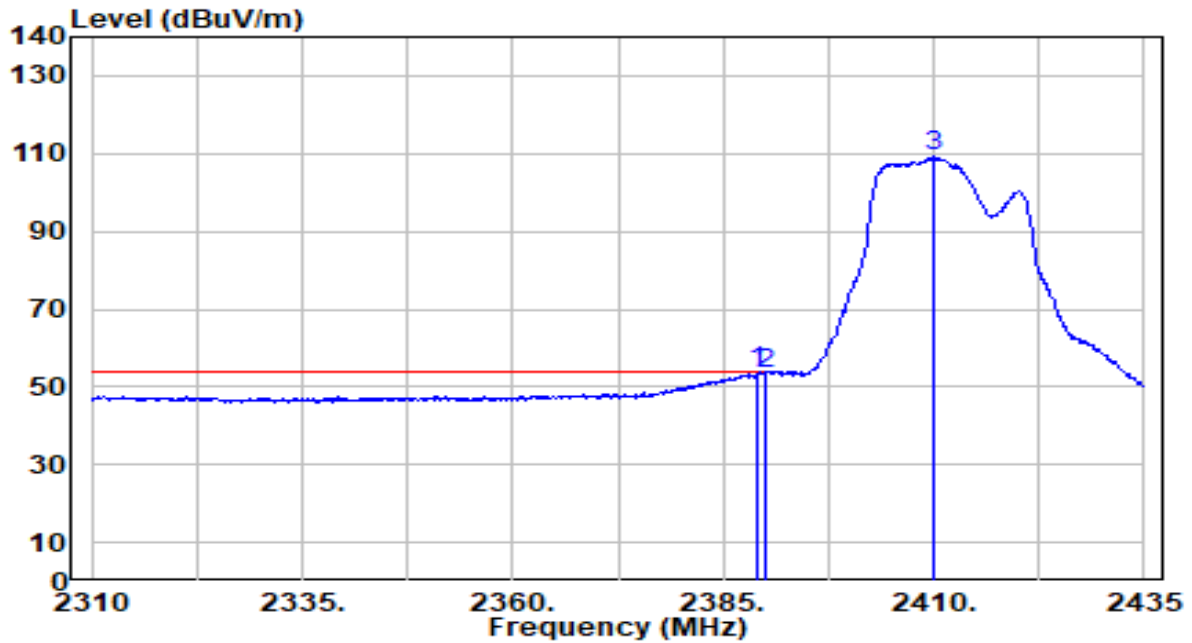

No	Frequency (MHz)	Reading (dBuV)	C.F (dB/m)	Measurement (dBuV/m)	Margin (dB)	Limit (dBuV/m)	Height (cm)	Angle (deg)	Remark (QP/PK/AV)
1	*	23.37	30.44	53.81	-0.19	54.00	100	110	Average
2		23.13	30.45	53.58	-0.42	54.00	100	110	Average
3		78.62	30.49	109.11	N/A	N/A	100	110	Average

Note:

1. " \*", means this data is the worst emission level.
2. C.F (Correction Factor) = Antenna Factor (dB/m) + Cable Loss (dB).
3. Measurement (dBuV/m) = Reading(dBuV) + C.F (Correction Factor).
4. The emission levels of other frequencies are very lower than the limit and not show in test report.

EUT	BE11000 Ceiling Mount Wi-Fi 7 Access Point	Date of Test	2024-05-27
Factor	DRH18-E	Temp. / Humidity	20°C /65%
Polarity	Vertical	Site / Test Engineer	AC2 / You
Test Mode	802.11n-20MHz_TX_CH 1 ANT 0+1	Test Voltage	AC 120V/60Hz

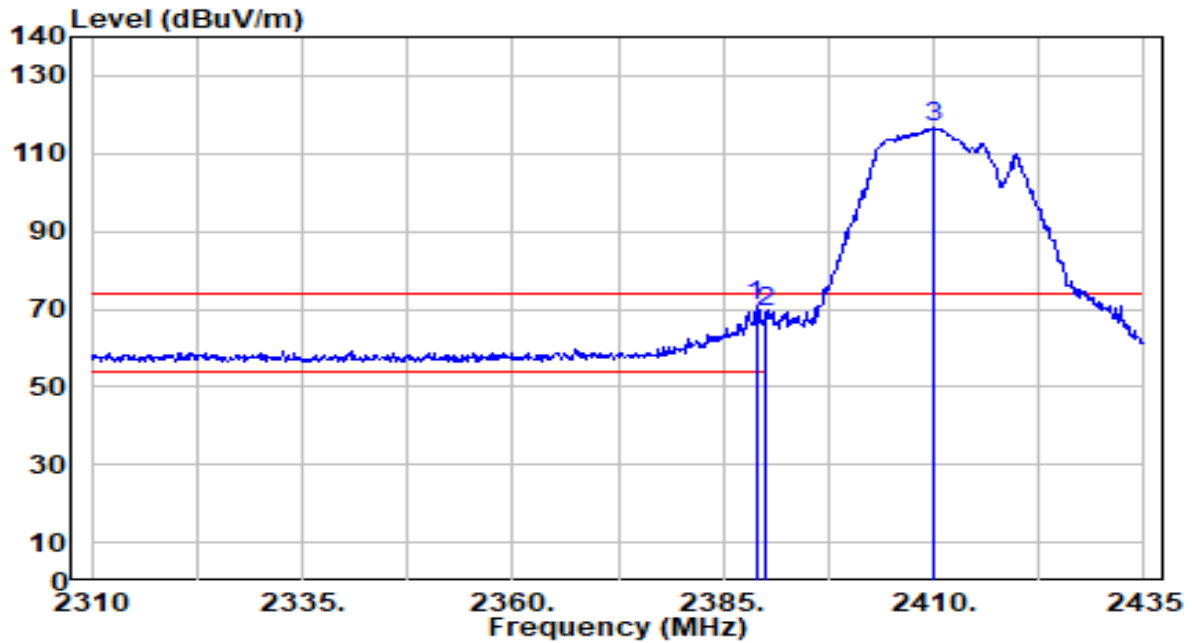

No	Frequency (MHz)	Reading (dBuV)	C.F (dB/m)	Measurement (dBuV/m)	Margin (dB)	Limit (dBuV/m)	Height (cm)	Angle (deg)	Remark (QP/PK/AV)	
1	*	2388.875	40.17	30.44	70.62	-3.38	74.00	176	158	Peak
2		2390.000	38.54	30.45	68.98	-5.02	74.00	176	158	Peak
3		2410.000	86.02	30.49	116.51	N/A	N/A	176	158	Peak

Note:

1. " \*", means this data is the worst emission level.
2. C.F (Correction Factor) = Antenna Factor (dB/m) + Cable Loss (dB).
3. Measurement (dBuV/m) = Reading(dBuV) + C.F (Correction Factor).
4. The emission levels of other frequencies are very lower than the limit and not show in test report.

EUT	BE11000 Ceiling Mount Wi-Fi 7 Access Point	Date of Test	2024-05-27
Factor	DRH18-E	Temp. / Humidity	20°C /65%
Polarity	Vertical	Site / Test Engineer	AC2 / You
Test Mode	802.11n-20MHz_TX_CH 1 ANT 0+1	Test Voltage	AC 120V/60Hz

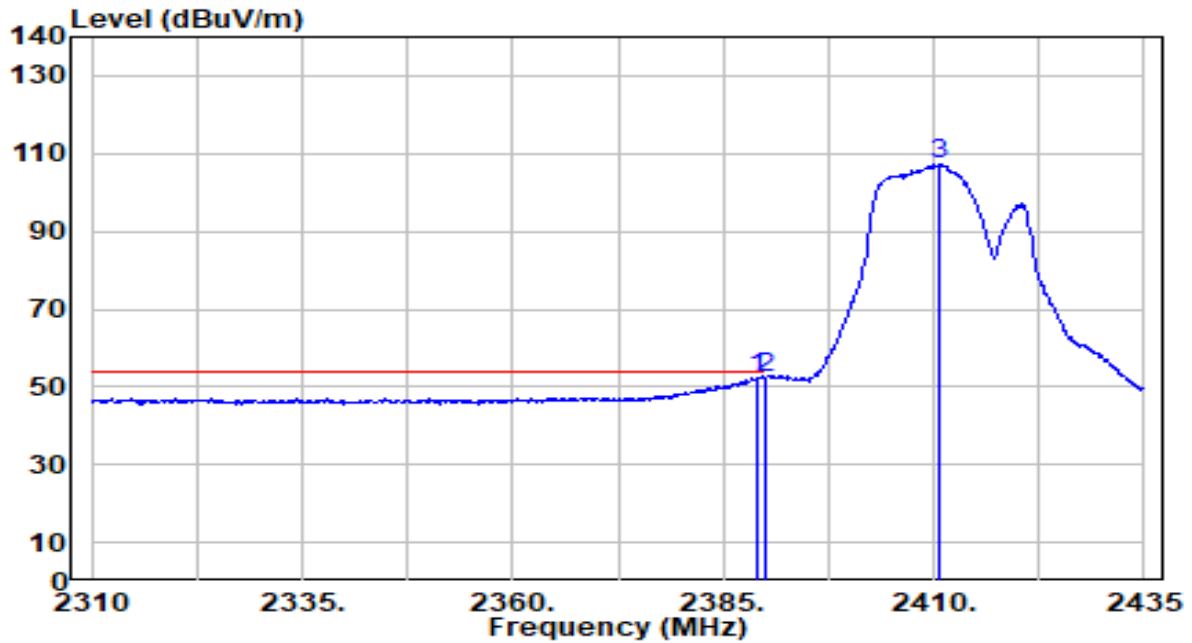

No	Frequency (MHz)	Reading (dBuV)	C.F (dB/m)	Measurement (dBuV/m)	Margin (dB)	Limit (dBuV/m)	Height (cm)	Angle (deg)	Remark (QP/PK/AV)
1	2389.000	21.65	30.44	52.10	-1.90	54.00	176	158	Average
2	* 2390.000	21.92	30.45	52.37	-1.63	54.00	176	158	Average
3	2410.625	76.85	30.49	107.34	N/A	N/A	176	158	Average

Note:

1. " \*", means this data is the worst emission level.
2. C.F (Correction Factor) = Antenna Factor (dB/m) + Cable Loss (dB).
3. Measurement (dBuV/m) = Reading(dBuV) + C.F (Correction Factor).
4. The emission levels of other frequencies are very lower than the limit and not show in test report.

EUT	BE11000 Ceiling Mount Wi-Fi 7 Access Point	Date of Test	2024-05-27
Factor	DRH18-E	Temp. / Humidity	20°C /65%
Polarity	Horizontal	Site / Test Engineer	AC2 / You
Test Mode	802.11n-20MHz_TX_CH 6 ANT 0+1	Test Voltage	AC 120V/60Hz

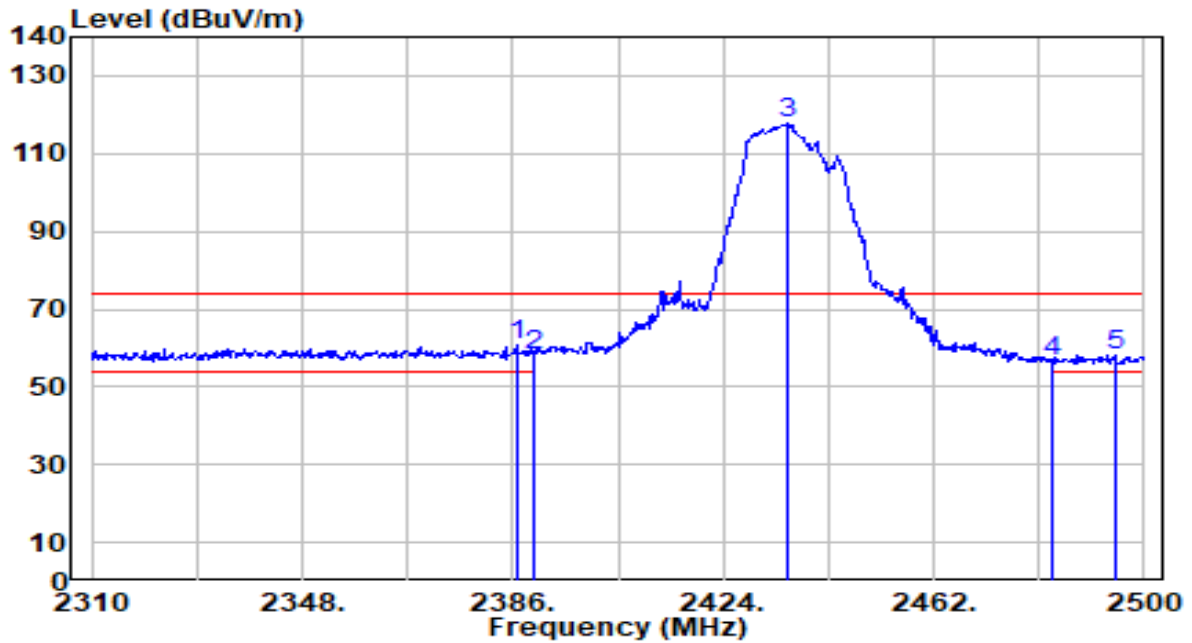

No	Frequency (MHz)	Reading (dBuV)	C.F (dB/m)	Measurement (dBuV/m)	Margin (dB)	Limit (dBuV/m)	Height (cm)	Angle (deg)	Remark (QP/PK/AV)	
1	*	2386.760	30.15	30.44	60.58	-13.42	74.00	100	110	Peak
2		2390.000	27.74	30.45	58.19	-15.81	74.00	100	110	Peak
3		2435.780	87.10	30.52	117.63	N/A	N/A	100	110	Peak
4		2483.500	26.11	30.59	56.70	-17.30	74.00	100	110	Peak
5		2494.870	27.50	30.60	58.10	-15.90	74.00	100	110	Peak

Note:

1. " \*", means this data is the worst emission level.
2. C.F (Correction Factor) = Antenna Factor (dB/m) + Cable Loss (dB).
3. Measurement (dBuV/m) = Reading(dBuV) + C.F (Correction Factor).
4. The emission levels of other frequencies are very lower than the limit and not show in test report.

EUT	BE11000 Ceiling Mount Wi-Fi 7 Access Point	Date of Test	2024-05-27
Factor	DRH18-E	Temp. / Humidity	20°C /65%
Polarity	Horizontal	Site / Test Engineer	AC2 / You
Test Mode	802.11n-20MHz_TX_CH 6 ANT 0+1	Test Voltage	AC 120V/60Hz

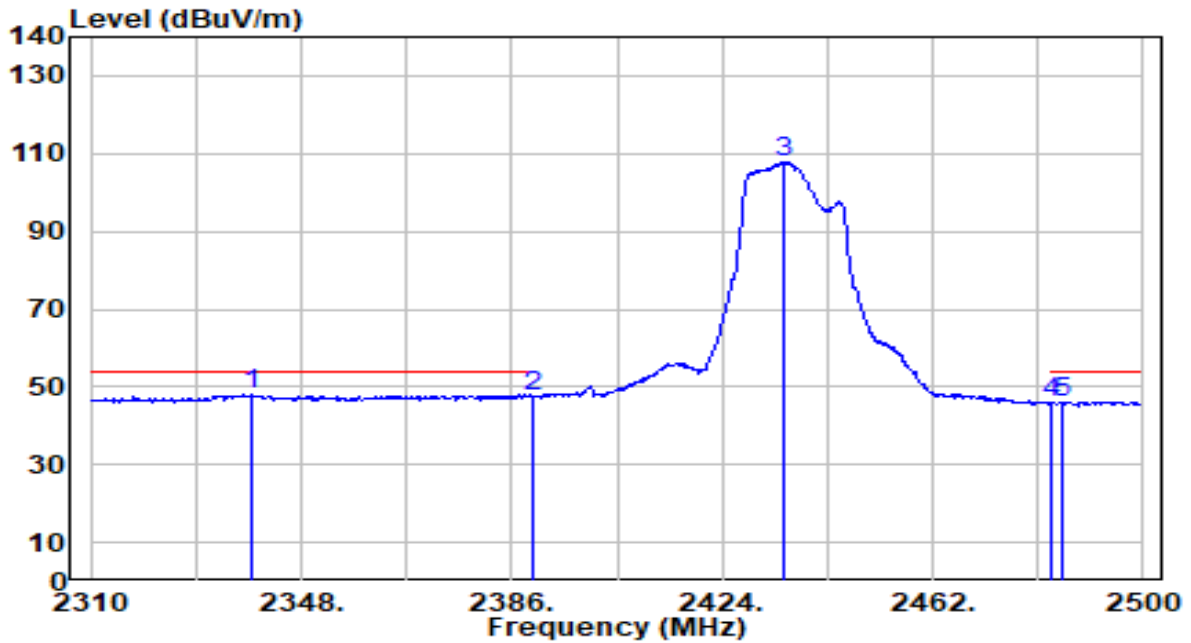

No	Frequency (MHz)	Reading (dBuV)	C.F (dB/m)	Measurement (dBuV/m)	Margin (dB)	Limit (dBuV/m)	Height (cm)	Angle (deg)	Remark (QP/PK/AV)
1	* 2339.070	17.64	30.30	47.94	-6.06	54.00	100	110	Average
2	2390.000	17.26	30.45	47.71	-6.29	54.00	100	110	Average
3	2435.210	77.39	30.52	107.91	N/A	N/A	100	110	Average
4	2483.500	15.19	30.59	45.77	-8.23	54.00	100	110	Average
5	2485.370	15.63	30.59	46.22	-7.78	54.00	100	110	Average

Note:

- " \*", means this data is the worst emission level.
- C.F (Correction Factor) = Antenna Factor (dB/m) + Cable Loss (dB).
- Measurement (dBuV/m) = Reading(dBuV) + C.F (Correction Factor).
- The emission levels of other frequencies are very lower than the limit and not show in test report.

EUT	BE11000 Ceiling Mount Wi-Fi 7 Access Point	Date of Test	2024-05-27
Factor	DRH18-E	Temp. / Humidity	20°C /65%
Polarity	Vertical	Site / Test Engineer	AC2 / You
Test Mode	802.11n-20MHz_TX_CH 6 ANT 0+1	Test Voltage	AC 120V/60Hz

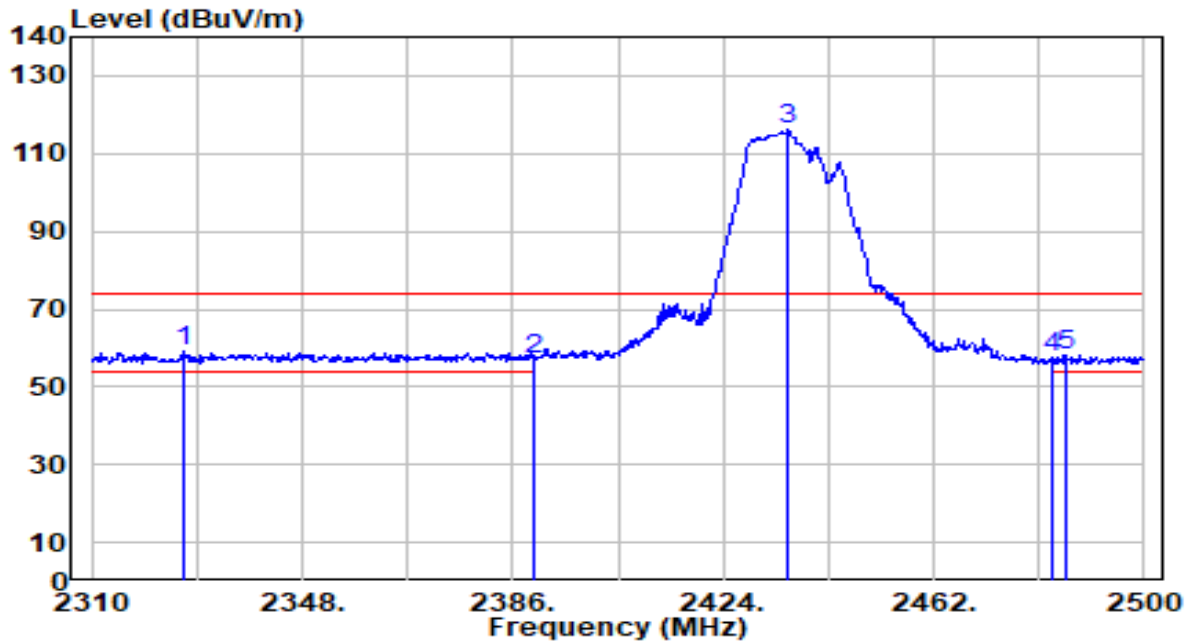

No	Frequency (MHz)	Reading (dBuV)	C.F (dB/m)	Measurement (dBuV/m)	Margin (dB)	Limit (dBuV/m)	Height (cm)	Angle (deg)	Remark (QP/PK/AV)
1	*	28.76	30.27	59.03	-14.97	74.00	176	158	Peak
2		26.74	30.45	57.18	-16.82	74.00	176	158	Peak
3		85.76	30.52	116.29	N/A	N/A	176	158	Peak
4		27.03	30.59	57.62	-16.38	74.00	176	158	Peak
5		27.74	30.59	58.33	-15.67	74.00	176	158	Peak

Note:

1. " \*", means this data is the worst emission level.
2. C.F (Correction Factor) = Antenna Factor (dB/m) + Cable Loss (dB).
3. Measurement (dBuV/m) = Reading(dBuV) + C.F (Correction Factor).
4. The emission levels of other frequencies are very lower than the limit and not show in test report.

EUT	BE11000 Ceiling Mount Wi-Fi 7 Access Point	Date of Test	2024-05-27
Factor	DRH18-E	Temp. / Humidity	20°C /65%
Polarity	Vertical	Site / Test Engineer	AC2 / You
Test Mode	802.11n-20MHz_TX_CH 6 ANT 0+1	Test Voltage	AC 120V/60Hz

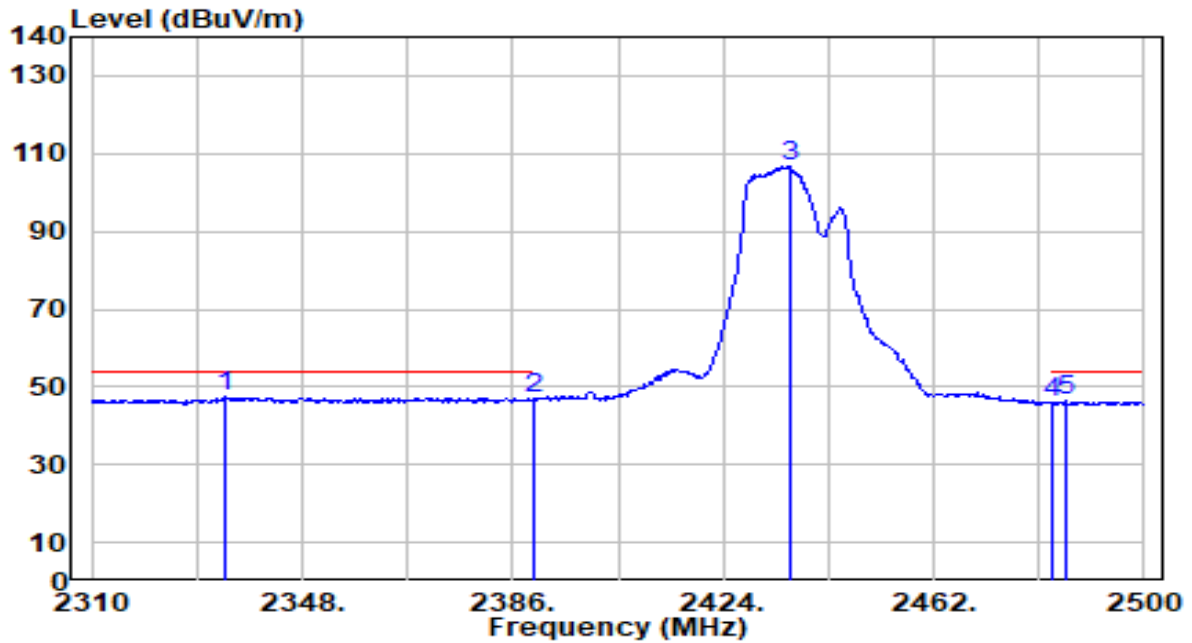

No	Frequency (MHz)	Reading (dBuV)	C.F (dB/m)	Measurement (dBuV/m)	Margin (dB)	Limit (dBuV/m)	Height (cm)	Angle (deg)	Remark (QP/PK/AV)	
1	*	2334.320	17.12	30.29	47.41	-6.59	54.00	176	158	Average
2		2390.000	16.60	30.45	47.05	-6.95	54.00	176	158	Average
3		2436.160	76.12	30.52	106.64	N/A	N/A	176	158	Average
4		2483.500	15.57	30.59	46.15	-7.85	54.00	176	158	Average
5		2485.750	15.67	30.59	46.26	-7.74	54.00	176	158	Average

Note:

- " \*", means this data is the worst emission level.
- C.F (Correction Factor) = Antenna Factor (dB/m) + Cable Loss (dB).
- Measurement (dBuV/m) = Reading(dBuV) + C.F (Correction Factor).
- The emission levels of other frequencies are very lower than the limit and not show in test report.



EUT	BE11000 Ceiling Mount Wi-Fi 7 Access Point	Date of Test	2024-05-27
Factor	DRH18-E	Temp. / Humidity	20°C /65%
Polarity	Horizontal	Site / Test Engineer	AC2 / You
Test Mode	802.11n-20MHz_TX_CH 11 ANT 0+1	Test Voltage	AC 120V/60Hz

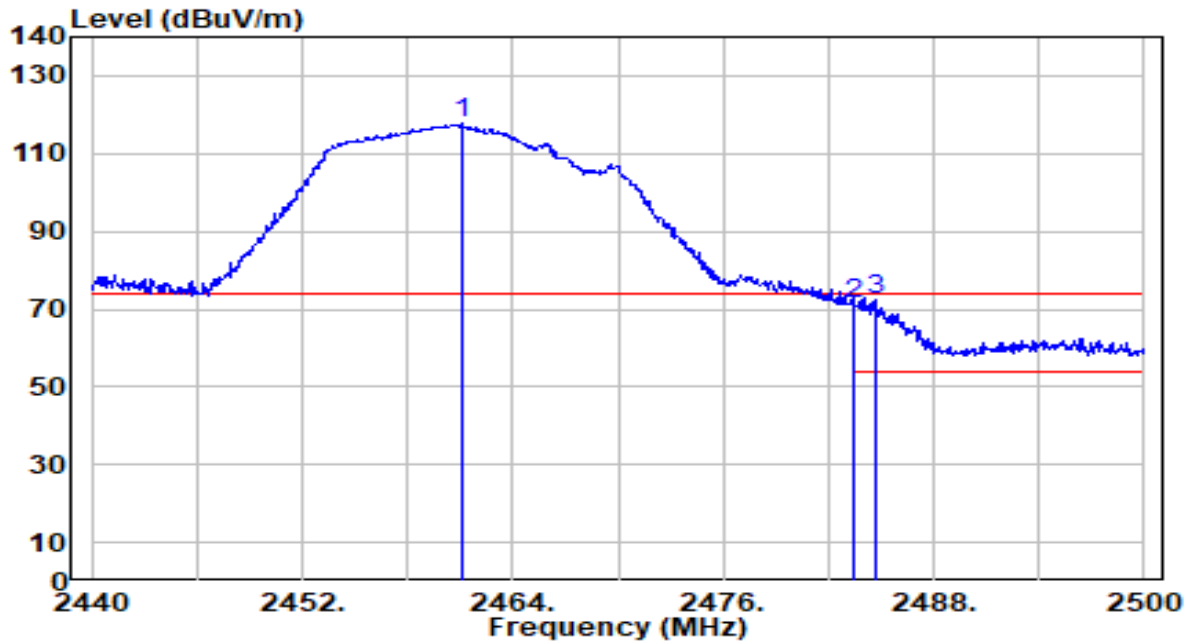

No	Frequency (MHz)	Reading (dBuV)	C.F (dB/m)	Measurement (dBuV/m)	Margin (dB)	Limit (dBuV/m)	Height (cm)	Angle (deg)	Remark (QP/PK/AV)
1	2461.060	87.41	30.56	117.97	N/A	N/A	100	110	Peak
2	2483.500	40.85	30.59	71.44	-2.56	74.00	100	110	Peak
3	* 2484.640	41.75	30.59	72.34	-1.66	74.00	100	110	Peak

Note:

1. " \*", means this data is the worst emission level.
2. C.F (Correction Factor) = Antenna Factor (dB/m) + Cable Loss (dB).
3. Measurement (dBuV/m) = Reading(dBuV) + C.F (Correction Factor).
4. The emission levels of other frequencies are very lower than the limit and not show in test report.

EUT	BE11000 Ceiling Mount Wi-Fi 7 Access Point	Date of Test	2024-05-27
Factor	DRH18-E	Temp. / Humidity	20°C /65%
Polarity	Horizontal	Site / Test Engineer	AC2 / You
Test Mode	802.11n-20MHz_TX_CH 11 ANT 0+1	Test Voltage	AC 120V/60Hz

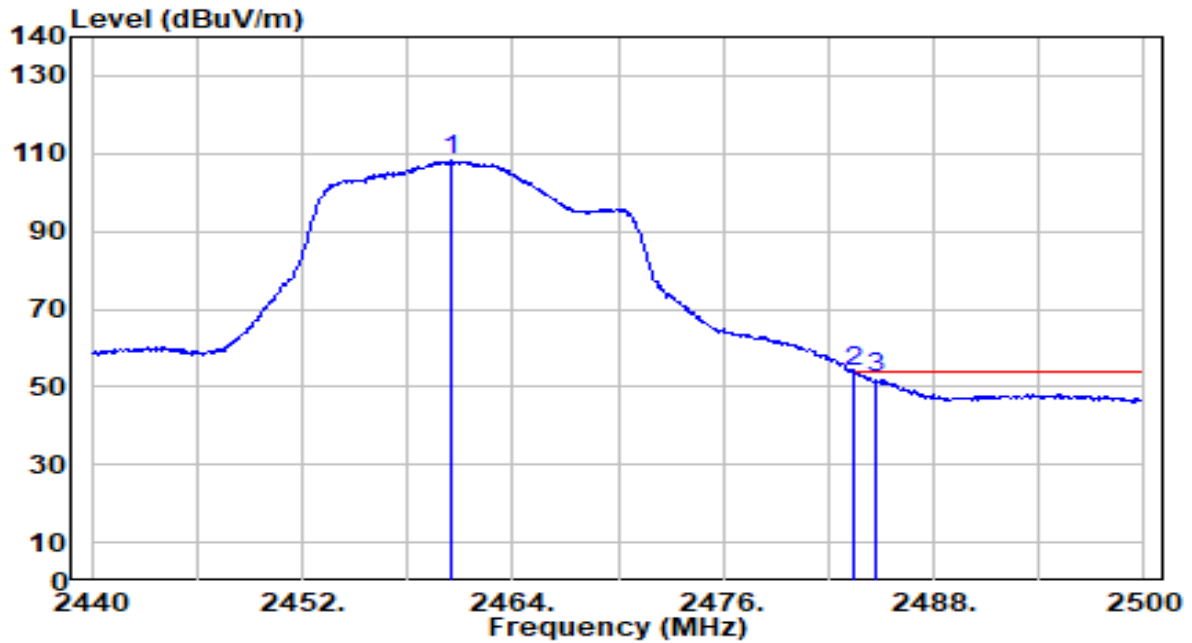

No	Frequency (MHz)	Reading (dBuV)	C.F (dB/m)	Measurement (dBuV/m)	Margin (dB)	Limit (dBuV/m)	Height (cm)	Angle (deg)	Remark (QP/PK/AV)
1	2460.520	77.75	30.56	108.30	N/A	N/A	100	110	Average
2	* 2483.500	23.16	30.59	53.75	-0.25	54.00	100	110	Average
3	2484.640	21.89	30.59	52.48	-1.52	54.00	100	110	Average

Note:

1. " \*", means this data is the worst emission level.
2. C.F (Correction Factor) = Antenna Factor (dB/m) + Cable Loss (dB).
3. Measurement (dBuV/m) = Reading(dBuV) + C.F (Correction Factor).
4. The emission levels of other frequencies are very lower than the limit and not show in test report.

EUT	BE11000 Ceiling Mount Wi-Fi 7 Access Point	Date of Test	2024-05-27
Factor	DRH18-E	Temp. / Humidity	20°C /65%
Polarity	Vertical	Site / Test Engineer	AC2 / You
Test Mode	802.11n-20MHz_TX_CH 11 ANT 0+1	Test Voltage	AC 120V/60Hz

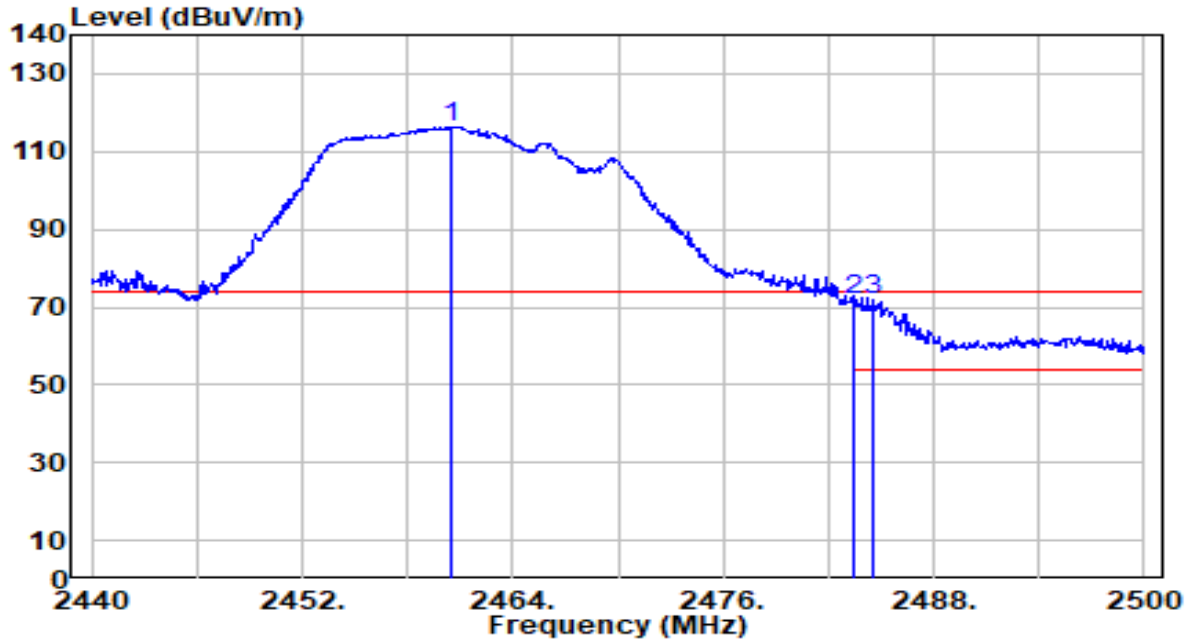

No	Frequency (MHz)	Reading (dBuV)	C.F (dB/m)	Measurement (dBuV/m)	Margin (dB)	Limit (dBuV/m)	Height (cm)	Angle (deg)	Remark (QP/PK/AV)
1	2460.520	85.84	30.56	116.40	N/A	N/A	182	157	Peak
2	* 2483.500	41.50	30.59	72.08	-1.92	74.00	182	157	Peak
3	2484.580	41.11	30.59	71.69	-2.31	74.00	182	157	Peak

Note:

1. " \*", means this data is the worst emission level.
2. C.F (Correction Factor) = Antenna Factor (dB/m) + Cable Loss (dB).
3. Measurement (dBuV/m) = Reading(dBuV) + C.F (Correction Factor).
4. The emission levels of other frequencies are very lower than the limit and not show in test report.

EUT	BE11000 Ceiling Mount Wi-Fi 7 Access Point	Date of Test	2024-05-27
Factor	DRH18-E	Temp. / Humidity	20°C /65%
Polarity	Vertical	Site / Test Engineer	AC2 / You
Test Mode	802.11n-20MHz_TX_CH 11 ANT 0+1	Test Voltage	AC 120V/60Hz

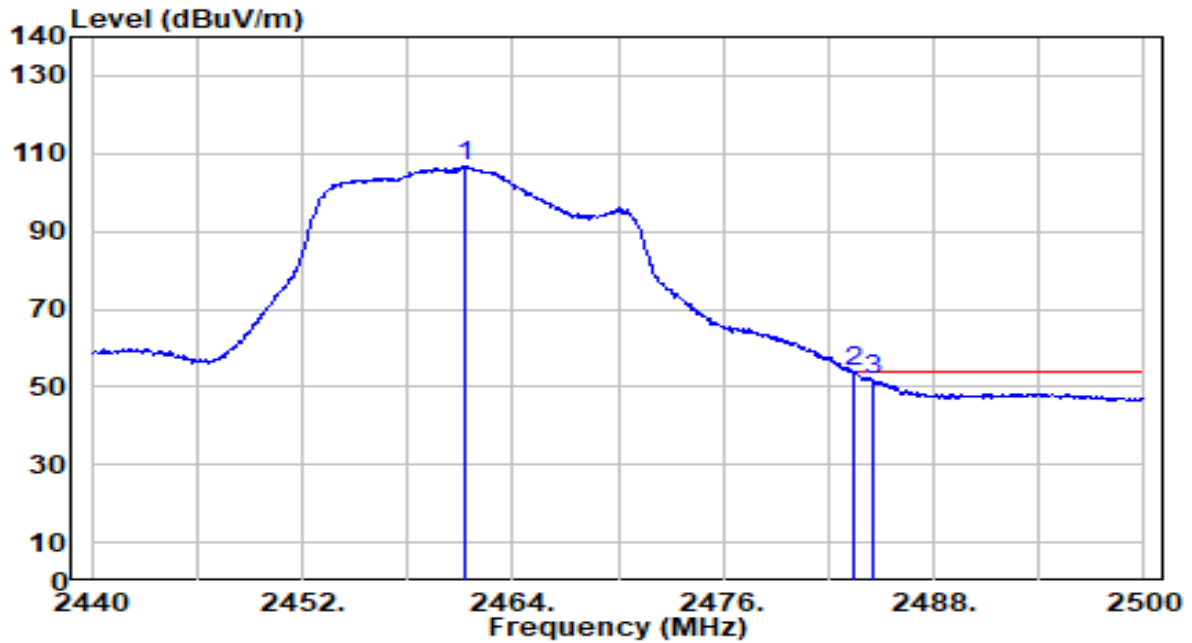

No	Frequency (MHz)	Reading (dBuV)	C.F (dB/m)	Measurement (dBuV/m)	Margin (dB)	Limit (dBuV/m)	Height (cm)	Angle (deg)	Remark (QP/PK/AV)
1	2461.300	76.10	30.56	106.66	N/A	N/A	182	157	Average
2	* 2483.500	23.19	30.59	53.78	-0.22	54.00	182	157	Average
3	2484.520	21.30	30.59	51.89	-2.11	54.00	182	157	Average

Note:

1. " \*", means this data is the worst emission level.
2. C.F (Correction Factor) = Antenna Factor (dB/m) + Cable Loss (dB).
3. Measurement (dBuV/m) = Reading(dBuV) + C.F (Correction Factor).
4. The emission levels of other frequencies are very lower than the limit and not show in test report.

EUT	BE11000 Ceiling Mount Wi-Fi 7 Access Point	Date of Test	2024-05-27
Factor	DRH18-E	Temp. / Humidity	20°C /65%
Polarity	Horizontal	Site / Test Engineer	AC2 / You
Test Mode	802.11n-40MHz_TX_CH 3 ANT 0+1	Test Voltage	AC 120V/60Hz

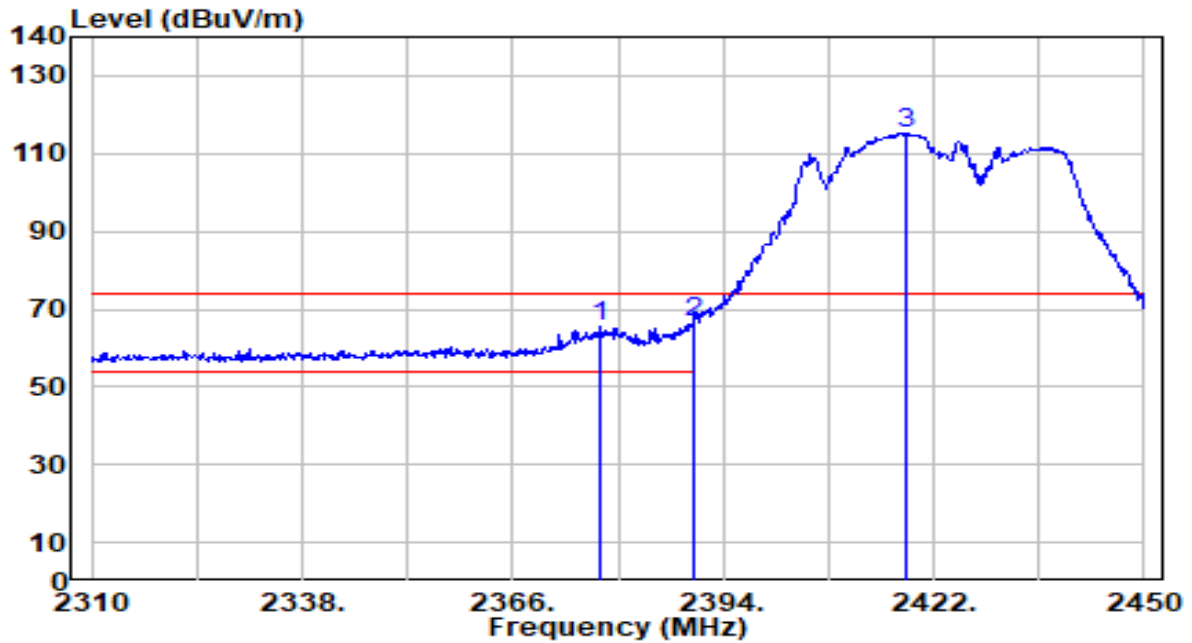

No	Frequency (MHz)	Reading (dBuV)	C.F (dB/m)	Measurement (dBuV/m)	Margin (dB)	Limit (dBuV/m)	Height (cm)	Angle (deg)	Remark (QP/PK/AV)
1	2377.760	35.14	30.41	65.56	-8.44	74.00	110	172	Peak
2	* 2390.000	36.24	30.45	66.69	-7.31	74.00	110	172	Peak
3	2418.220	84.89	30.50	115.39	N/A	N/A	110	172	Peak

Note:

1. " \*", means this data is the worst emission level.
2. C.F (Correction Factor) = Antenna Factor (dB/m) + Cable Loss (dB).
3. Measurement (dBuV/m) = Reading(dBuV) + C.F (Correction Factor).
4. The emission levels of other frequencies are very lower than the limit and not show in test report.

EUT	BE11000 Ceiling Mount Wi-Fi 7 Access Point	Date of Test	2024-05-27
Factor	DRH18-E	Temp. / Humidity	20°C /65%
Polarity	Horizontal	Site / Test Engineer	AC2 / You
Test Mode	802.11n-40MHz_TX_CH 3 ANT 0+1	Test Voltage	AC 120V/60Hz

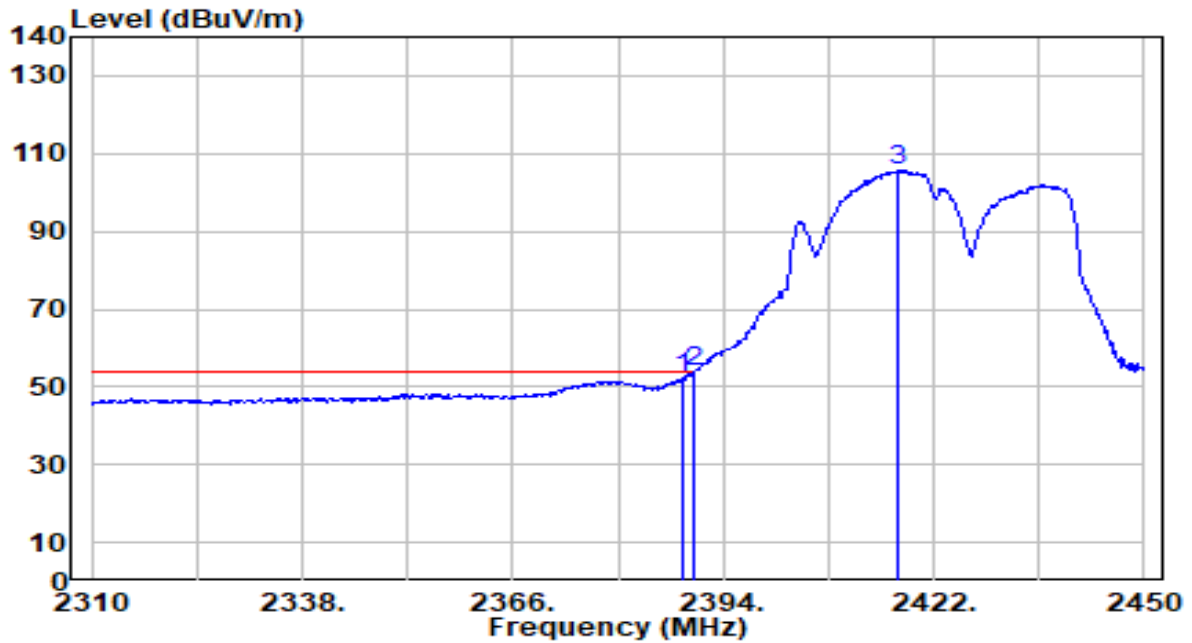

No	Frequency (MHz)	Reading (dBuV)	C.F (dB/m)	Measurement (dBuV/m)	Margin (dB)	Limit (dBuV/m)	Height (cm)	Angle (deg)	Remark (QP/PK/AV)
1	2388.680	21.98	30.44	52.42	-1.58	54.00	110	172	Average
2	* 2390.000	23.32	30.45	53.77	-0.23	54.00	110	172	Average
3	2417.240	75.16	30.50	105.66	N/A	N/A	110	172	Average

Note:

1. " \*", means this data is the worst emission level.
2. C.F (Correction Factor) = Antenna Factor (dB/m) + Cable Loss (dB).
3. Measurement (dBuV/m) = Reading(dBuV) + C.F (Correction Factor).
4. The emission levels of other frequencies are very lower than the limit and not show in test report.

EUT	BE11000 Ceiling Mount Wi-Fi 7 Access Point	Date of Test	2024-05-27
Factor	DRH18-E	Temp. / Humidity	20°C /65%
Polarity	Vertical	Site / Test Engineer	AC2 / You
Test Mode	802.11n-40MHz_TX_CH 3 ANT 0+1	Test Voltage	AC 120V/60Hz

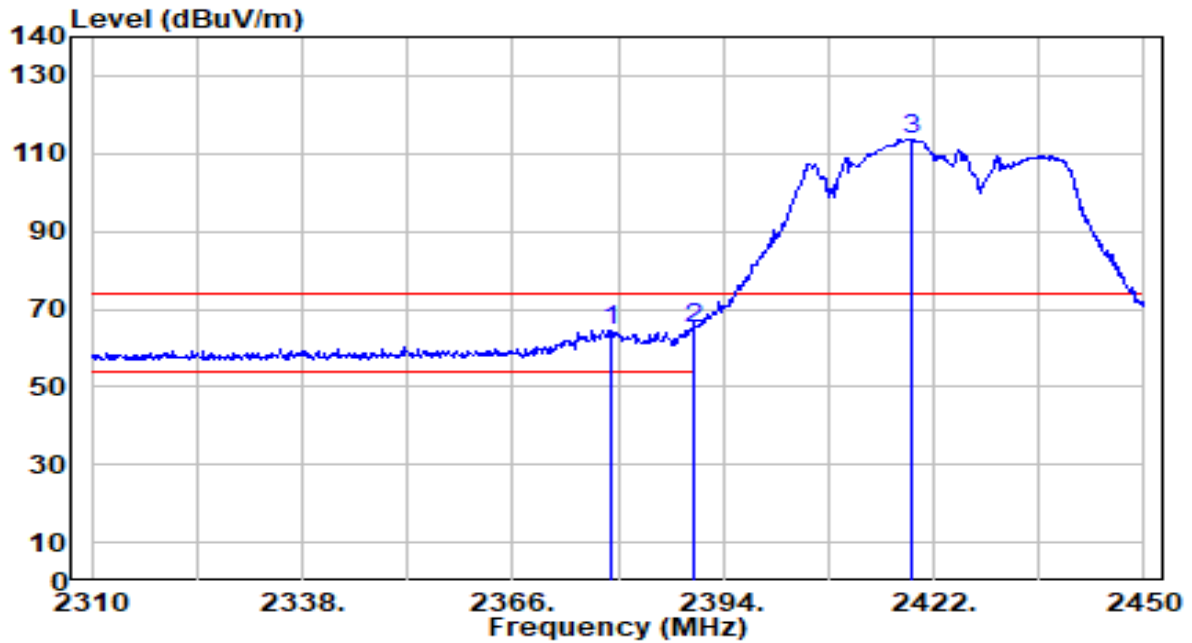

No	Frequency (MHz)	Reading (dBuV)	C.F (dB/m)	Measurement (dBuV/m)	Margin (dB)	Limit (dBuV/m)	Height (cm)	Angle (deg)	Remark (QP/PK/AV)
1	2379.160	34.11	30.42	64.52	-9.48	74.00	175	157	Peak
2	* 2390.000	34.34	30.45	64.78	-9.22	74.00	175	157	Peak
3	2419.200	83.26	30.50	113.76	N/A	N/A	175	157	Peak

Note:

1. " \*", means this data is the worst emission level.
2. C.F (Correction Factor) = Antenna Factor (dB/m) + Cable Loss (dB).
3. Measurement (dBuV/m) = Reading(dBuV) + C.F (Correction Factor).
4. The emission levels of other frequencies are very lower than the limit and not show in test report.

EUT	BE11000 Ceiling Mount Wi-Fi 7 Access Point	Date of Test	2024-05-27
Factor	DRH18-E	Temp. / Humidity	20°C /65%
Polarity	Vertical	Site / Test Engineer	AC2 / You
Test Mode	802.11n-40MHz_TX_CH 3 ANT 0+1	Test Voltage	AC 120V/60Hz

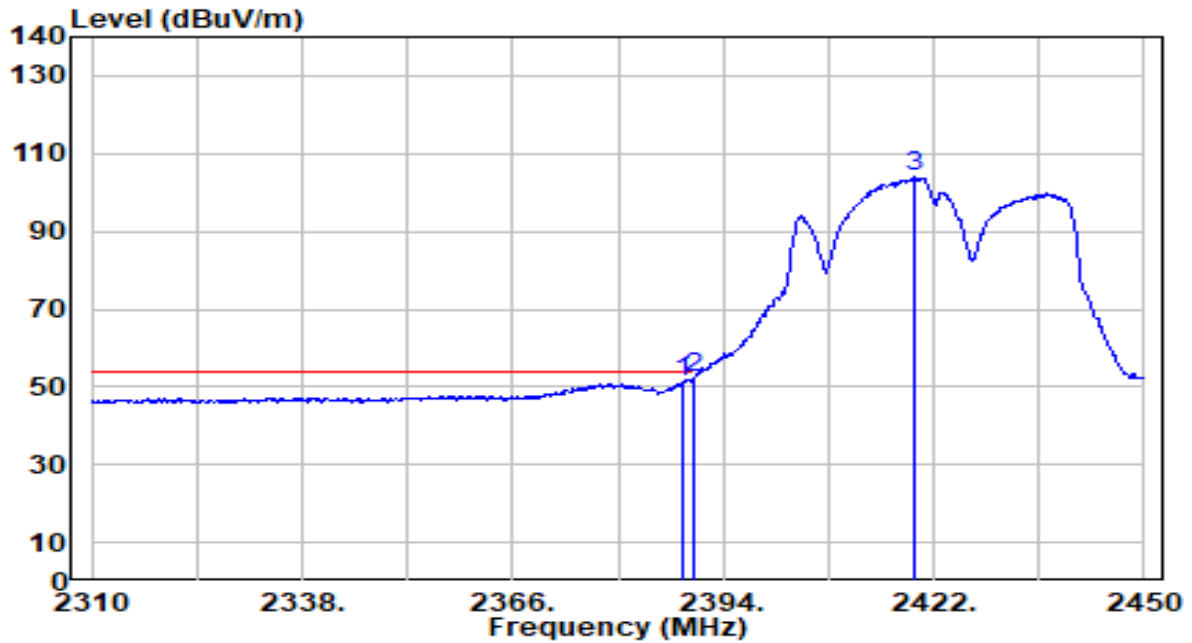

No	Frequency (MHz)	Reading (dBuV)	C.F (dB/m)	Measurement (dBuV/m)	Margin (dB)	Limit (dBuV/m)	Height (cm)	Angle (deg)	Remark (QP/PK/AV)
1	2388.680	20.94	30.44	51.38	-2.62	54.00	175	157	Average
2	* 2390.000	21.92	30.45	52.36	-1.64	54.00	175	157	Average
3	2419.340	73.36	30.50	103.87	N/A	N/A	175	157	Average

Note:

1. " \*", means this data is the worst emission level.
2. C.F (Correction Factor) = Antenna Factor (dB/m) + Cable Loss (dB).
3. Measurement (dBuV/m) = Reading(dBuV) + C.F (Correction Factor).
4. The emission levels of other frequencies are very lower than the limit and not show in test report.



EUT	BE11000 Ceiling Mount Wi-Fi 7 Access Point	Date of Test	2024-05-27
Factor	DRH18-E	Temp. / Humidity	20°C /65%
Polarity	Horizontal	Site / Test Engineer	AC2 / You
Test Mode	802.11n-40MHz_TX_CH 6 ANT 0+1	Test Voltage	AC 120V/60Hz

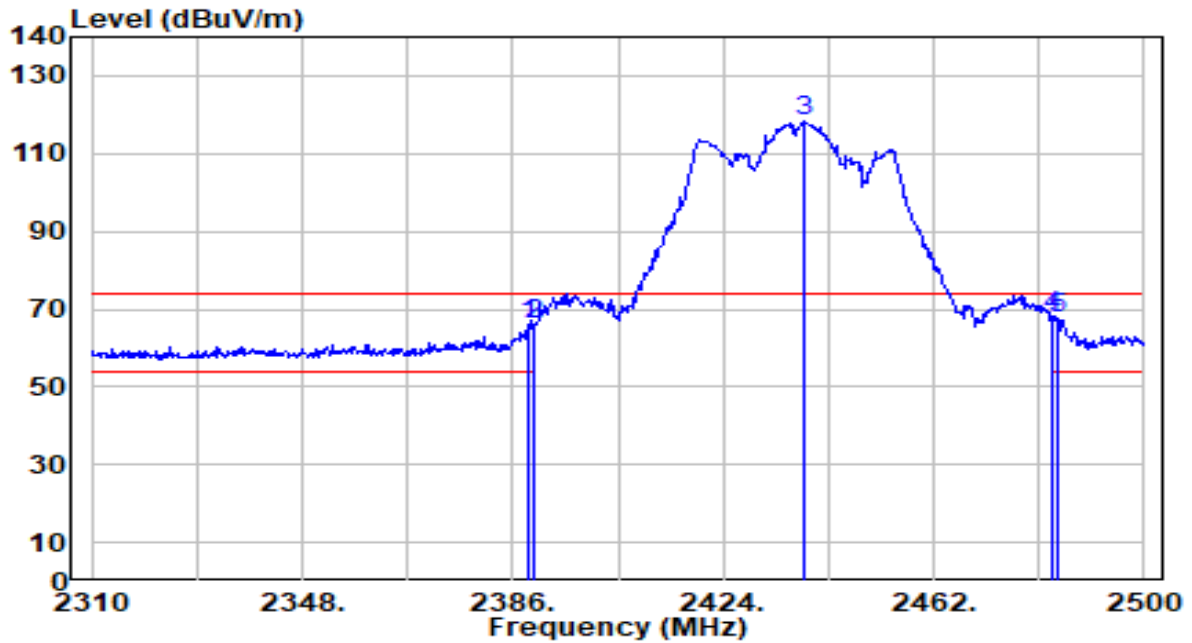

No	Frequency (MHz)	Reading (dBuV)	C.F (dB/m)	Measurement (dBuV/m)	Margin (dB)	Limit (dBuV/m)	Height (cm)	Angle (deg)	Remark (QP/PK/AV)
1	2388.850	35.65	30.44	66.09	-7.91	74.00	114	182	Peak
2	2390.000	35.65	30.45	66.10	-7.90	74.00	114	182	Peak
3	2438.630	87.63	30.53	118.16	N/A	N/A	114	182	Peak
4	* 2483.500	37.41	30.59	68.00	-6.00	74.00	114	182	Peak
5	2484.230	36.80	30.59	67.39	-6.61	74.00	114	182	Peak

Note:

- "\*" means this data is the worst emission level.
- C.F (Correction Factor) = Antenna Factor (dB/m) + Cable Loss (dB).
- Measurement (dBuV/m) = Reading(dBuV) + C.F (Correction Factor).
- The emission levels of other frequencies are very lower than the limit and not show in test report.

EUT	BE11000 Ceiling Mount Wi-Fi 7 Access Point	Date of Test	2024-05-27
Factor	DRH18-E	Temp. / Humidity	20°C /65%
Polarity	Horizontal	Site / Test Engineer	AC2 / You
Test Mode	802.11n-40MHz_TX_CH 6 ANT 0+1	Test Voltage	AC 120V/60Hz

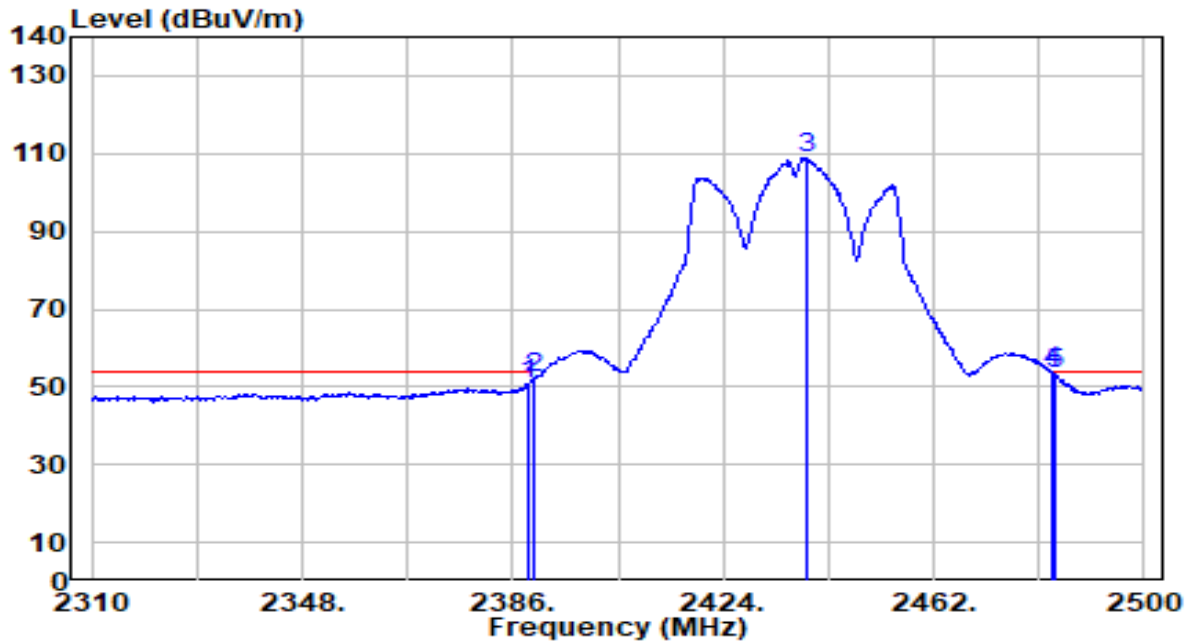

No	Frequency (MHz)	Reading (dBuV)	C.F (dB/m)	Measurement (dBuV/m)	Margin (dB)	Limit (dBuV/m)	Height (cm)	Angle (deg)	Remark (QP/PK/AV)
1	2389.040	20.51	30.44	50.96	-3.04	54.00	114	182	Average
2	2390.000	21.64	30.45	52.08	-1.92	54.00	114	182	Average
3	2439.010	78.26	30.53	108.79	N/A	N/A	114	182	Average
4	* 2483.500	23.30	30.59	53.88	-0.12	54.00	114	182	Average
5	2484.040	22.76	30.59	53.35	-0.65	54.00	114	182	Average

Note:

1. " \*", means this data is the worst emission level.
2. C.F (Correction Factor) = Antenna Factor (dB/m) + Cable Loss (dB).
3. Measurement (dBuV/m) = Reading(dBuV) + C.F (Correction Factor).
4. The emission levels of other frequencies are very lower than the limit and not show in test report.

EUT	BE11000 Ceiling Mount Wi-Fi 7 Access Point	Date of Test	2024-05-27
Factor	DRH18-E	Temp. / Humidity	20°C /65%
Polarity	Vertical	Site / Test Engineer	AC2 / You
Test Mode	802.11n-40MHz_TX_CH 6 ANT 0+1	Test Voltage	AC 120V/60Hz

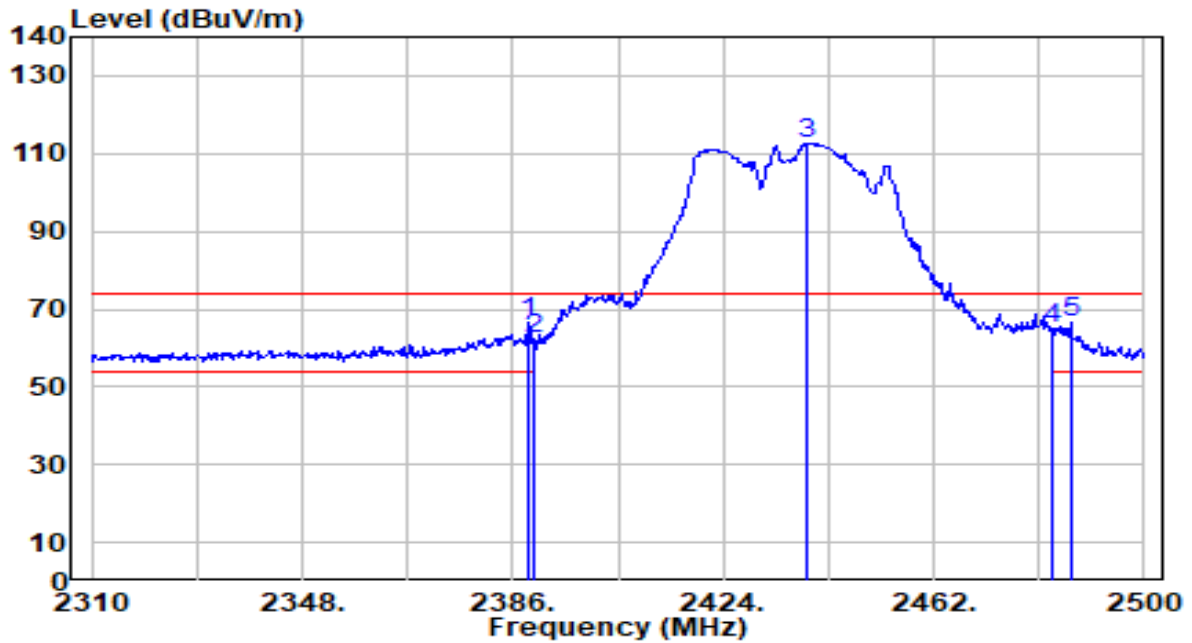

No	Frequency (MHz)	Reading (dBuV)	C.F (dB/m)	Measurement (dBuV/m)	Margin (dB)	Limit (dBuV/m)	Height (cm)	Angle (deg)	Remark (QP/PK/AV)
1	* 2389.040	36.07	30.44	66.51	-7.49	74.00	175	157	Peak
2	2390.000	32.02	30.45	62.47	-11.53	74.00	175	157	Peak
3	2439.010	82.21	30.53	112.74	N/A	N/A	175	157	Peak
4	2483.500	34.57	30.59	65.16	-8.84	74.00	175	157	Peak
5	2486.700	35.85	30.59	66.44	-7.56	74.00	175	157	Peak

Note:

- " \*", means this data is the worst emission level.
- C.F (Correction Factor) = Antenna Factor (dB/m) + Cable Loss (dB).
- Measurement (dBuV/m) = Reading(dBuV) + C.F (Correction Factor).
- The emission levels of other frequencies are very lower than the limit and not show in test report.

EUT	BE11000 Ceiling Mount Wi-Fi 7 Access Point	Date of Test	2024-05-27
Factor	DRH18-E	Temp. / Humidity	20°C /65%
Polarity	Vertical	Site / Test Engineer	AC2 / You
Test Mode	802.11n-40MHz_TX_CH 6 ANT 0+1	Test Voltage	AC 120V/60Hz

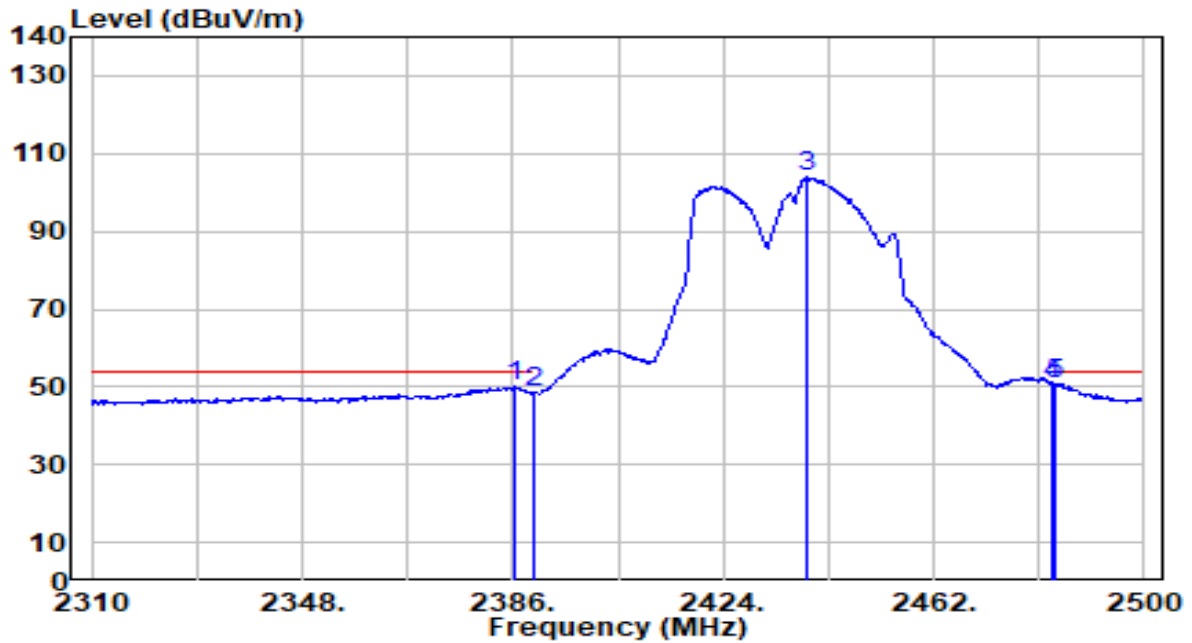

No	Frequency (MHz)	Reading (dBuV)	C.F (dB/m)	Measurement (dBuV/m)	Margin (dB)	Limit (dBuV/m)	Height (cm)	Angle (deg)	Remark (QP/PK/AV)
1	2386.570	19.60	30.44	50.04	-3.96	54.00	175	157	Average
2	2390.000	18.01	30.45	48.45	-5.55	54.00	175	157	Average
3	2439.200	73.31	30.53	103.83	N/A	N/A	175	157	Average
4	* 2483.500	20.25	30.59	50.84	-3.16	54.00	175	157	Average
5	2484.040	20.22	30.59	50.81	-3.19	54.00	175	157	Average

Note:

- "\*" means this data is the worst emission level.
- C.F (Correction Factor) = Antenna Factor (dB/m) + Cable Loss (dB).
- Measurement (dBuV/m) = Reading(dBuV) + C.F (Correction Factor).
- The emission levels of other frequencies are very lower than the limit and not show in test report.

EUT	BE11000 Ceiling Mount Wi-Fi 7 Access Point	Date of Test	2024-05-27
Factor	DRH18-E	Temp. / Humidity	20°C /65%
Polarity	Horizontal	Site / Test Engineer	AC2 / You
Test Mode	802.11n-40MHz_TX_CH 9 ANT 0+1	Test Voltage	AC 120V/60Hz

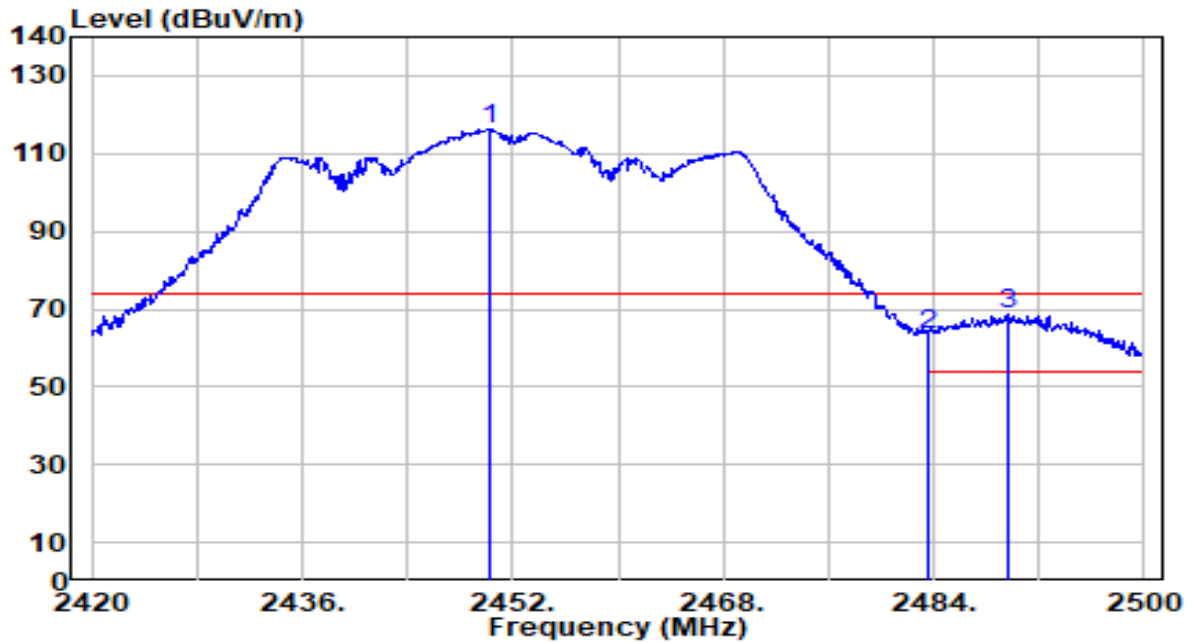

No	Frequency (MHz)	Reading (dBuV)	C.F (dB/m)	Measurement (dBuV/m)	Margin (dB)	Limit (dBuV/m)	Height (cm)	Angle (deg)	Remark (QP/PK/AV)
1	2450.240	85.74	30.54	116.28	N/A	N/A	128	189	Peak
2	2483.500	33.04	30.59	63.63	-10.37	74.00	128	189	Peak
3	* 2489.600	37.95	30.60	68.55	-5.45	74.00	128	189	Peak

Note:

1. " \*", means this data is the worst emission level.
2. C.F (Correction Factor) = Antenna Factor (dB/m) + Cable Loss (dB).
3. Measurement (dBuV/m) = Reading(dBuV) + C.F (Correction Factor).
4. The emission levels of other frequencies are very lower than the limit and not show in test report.

EUT	BE11000 Ceiling Mount Wi-Fi 7 Access Point	Date of Test	2024-05-27
Factor	DRH18-E	Temp. / Humidity	20°C /65%
Polarity	Horizontal	Site / Test Engineer	AC2 / You
Test Mode	802.11n-40MHz_TX_CH 9 ANT 0+1	Test Voltage	AC 120V/60Hz

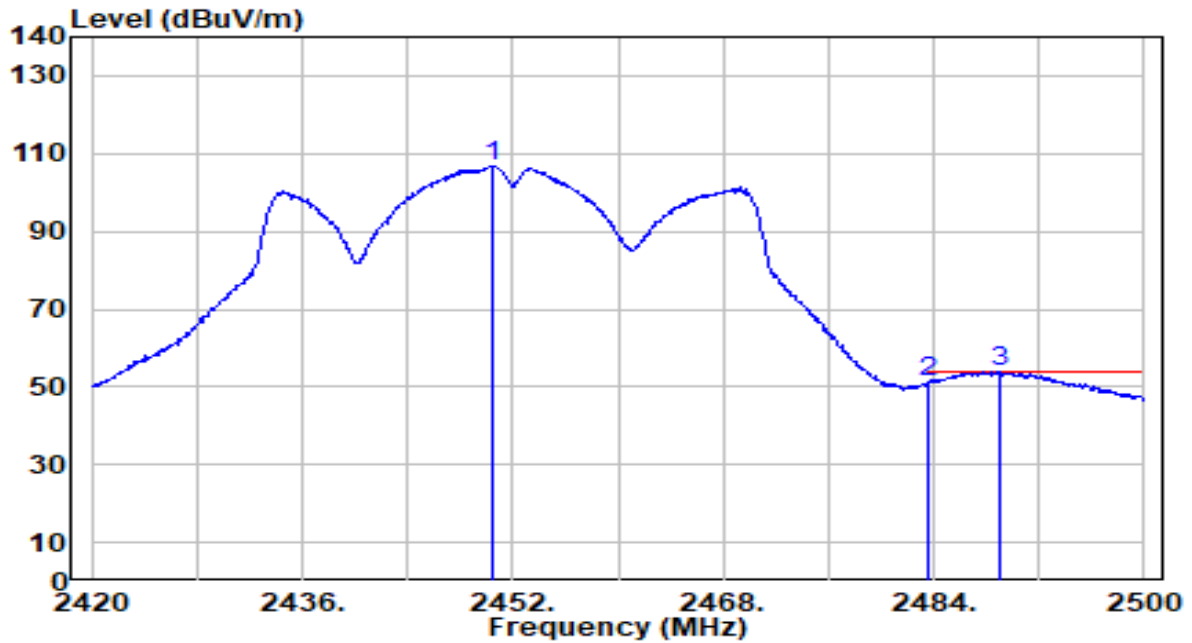

No	Frequency (MHz)	Reading (dBuV)	C.F (dB/m)	Measurement (dBuV/m)	Margin (dB)	Limit (dBuV/m)	Height (cm)	Angle (deg)	Remark (QP/PK/AV)
1	2450.480	76.28	30.54	106.82	N/A	N/A	128	189	Average
2	2483.500	20.47	30.59	51.06	-2.94	54.00	128	189	Average
3	* 2489.040	23.22	30.60	53.81	-0.19	54.00	128	189	Average

Note:

1. " \*", means this data is the worst emission level.
2. C.F (Correction Factor) = Antenna Factor (dB/m) + Cable Loss (dB).
3. Measurement (dBuV/m) = Reading(dBuV) + C.F (Correction Factor).
4. The emission levels of other frequencies are very lower than the limit and not show in test report.

EUT	BE11000 Ceiling Mount Wi-Fi 7 Access Point	Date of Test	2024-05-27
Factor	DRH18-E	Temp. / Humidity	20°C /65%
Polarity	Vertical	Site / Test Engineer	AC2 / You
Test Mode	802.11n-40MHz_TX_CH 9 ANT 0+1	Test Voltage	AC 120V/60Hz

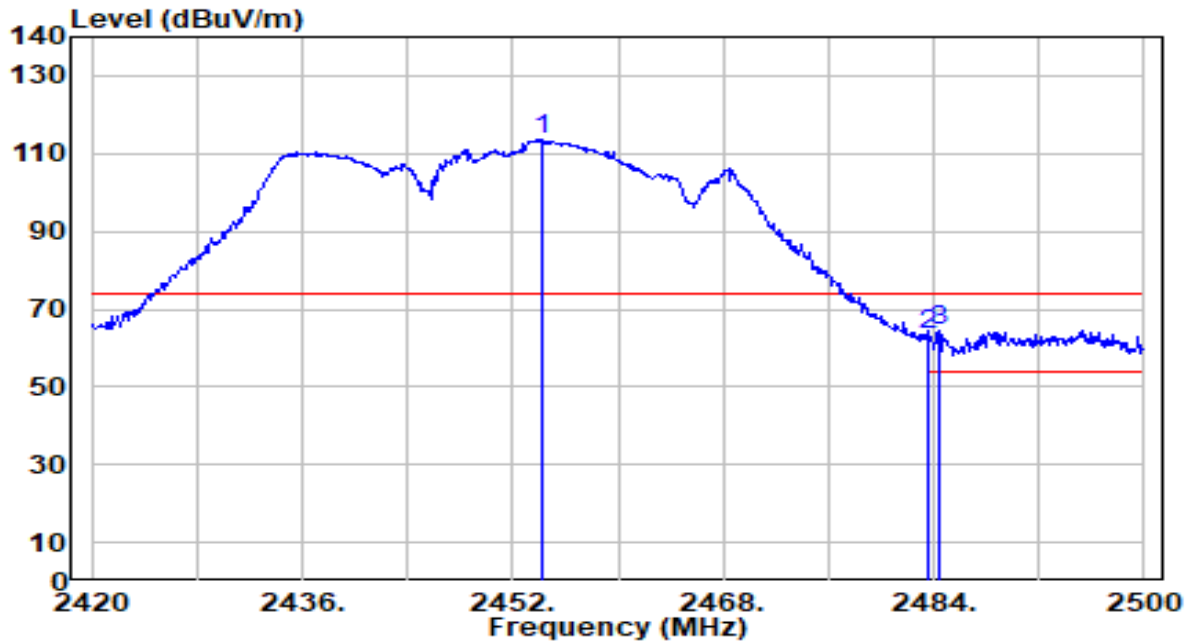

No	Frequency (MHz)	Reading (dBuV)	C.F (dB/m)	Measurement (dBuV/m)	Margin (dB)	Limit (dBuV/m)	Height (cm)	Angle (deg)	Remark (QP/PK/AV)
1	2454.160	82.80	30.55	113.35	N/A	N/A	150	167	Peak
2	2483.500	33.01	30.59	63.60	-10.40	74.00	150	167	Peak
3	* 2484.480	33.97	30.59	64.56	-9.44	74.00	150	167	Peak

Note:

1. " \*", means this data is the worst emission level.
2. C.F (Correction Factor) = Antenna Factor (dB/m) + Cable Loss (dB).
3. Measurement (dBuV/m) = Reading(dBuV) + C.F (Correction Factor).
4. The emission levels of other frequencies are very lower than the limit and not show in test report.

EUT	BE11000 Ceiling Mount Wi-Fi 7 Access Point	Date of Test	2024-05-27
Factor	DRH18-E	Temp. / Humidity	20°C /65%
Polarity	Vertical	Site / Test Engineer	AC2 / You
Test Mode	802.11n-40MHz_TX_CH 9 ANT 0+1	Test Voltage	AC 120V/60Hz

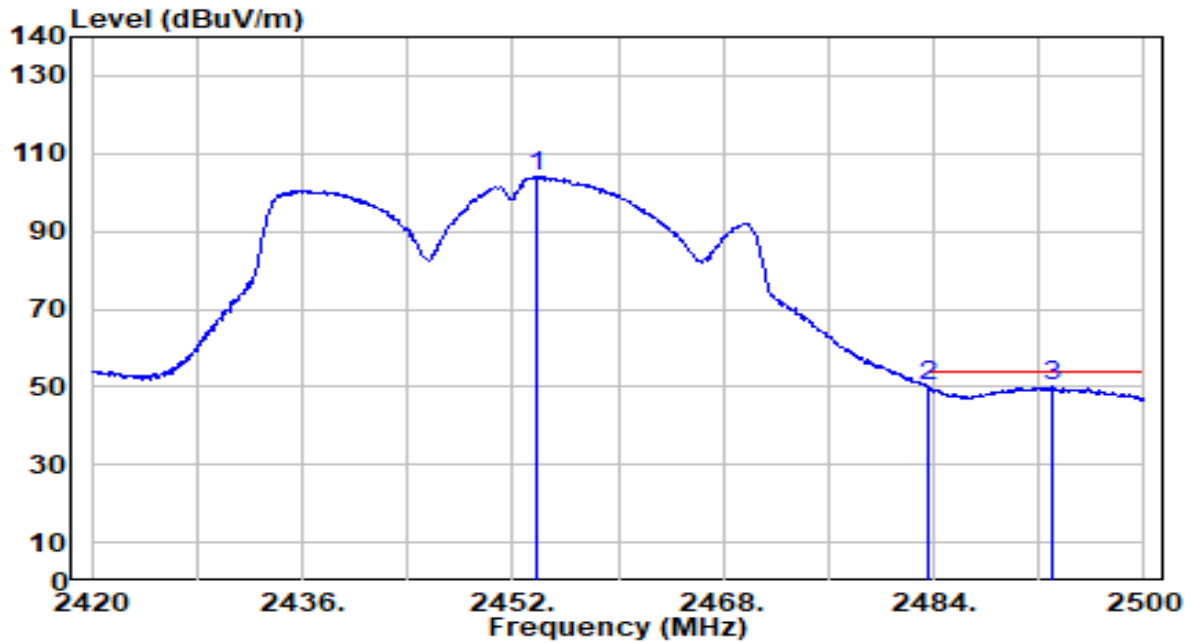

No	Frequency (MHz)	Reading (dBuV)	C.F (dB/m)	Measurement (dBuV/m)	Margin (dB)	Limit (dBuV/m)	Height (cm)	Angle (deg)	Remark (QP/PK/AV)
1	2453.920	73.77	30.55	104.32	N/A	N/A	150	167	Average
2	* 2483.500	19.85	30.59	50.44	-3.56	54.00	150	167	Average
3	2493.040	19.41	30.60	50.01	-3.99	54.00	150	167	Average

Note:

1. " \*", means this data is the worst emission level.
2. C.F (Correction Factor) = Antenna Factor (dB/m) + Cable Loss (dB).
3. Measurement (dBuV/m) = Reading(dBuV) + C.F (Correction Factor).
4. The emission levels of other frequencies are very lower than the limit and not show in test report.



EUT	BE11000 Ceiling Mount Wi-Fi 7 Access Point	Date of Test	2024-05-27
Factor	DRH18-E	Temp. / Humidity	20°C /65%
Polarity	Horizontal	Site / Test Engineer	AC2 / You
Test Mode	802.11ax-20MHz_TX_CH 1 ANT 0+1	Test Voltage	AC 120V/60Hz

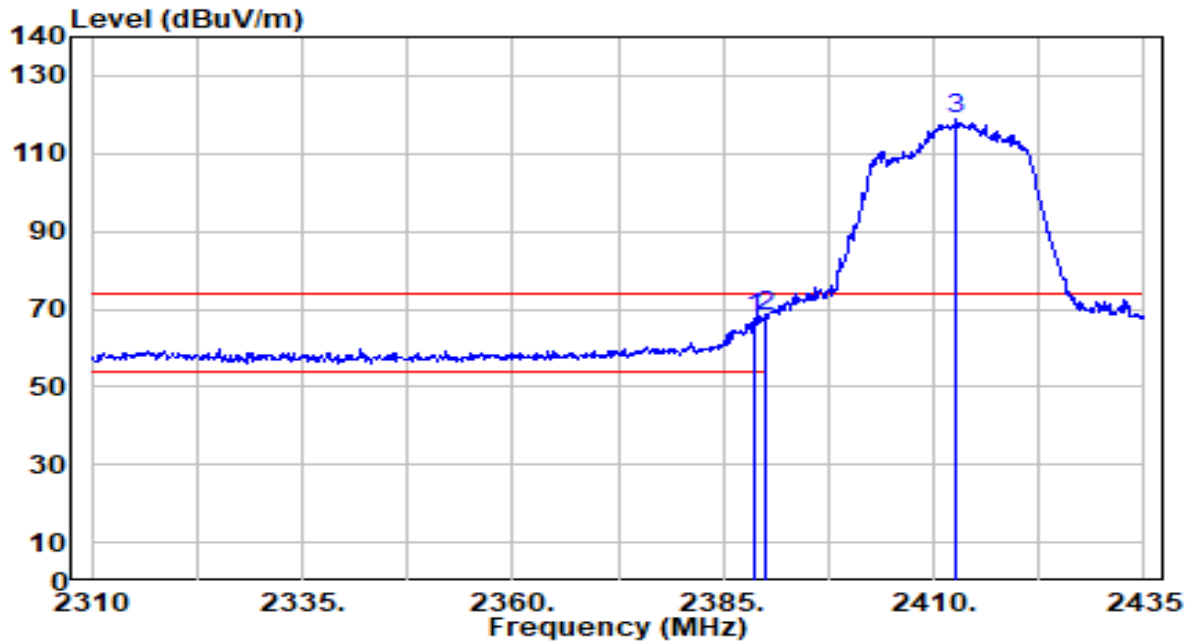

No	Frequency (MHz)	Reading (dBUV)	C.F (dB/m)	Measurement (dBUV/m)	Margin (dB)	Limit (dBUV/m)	Height (cm)	Angle (deg)	Remark (QP/PK/AV)
1	2388.625	37.28	30.44	67.73	-6.27	74.00	100	266	Peak
2	* 2390.000	37.62	30.45	68.07	-5.93	74.00	100	266	Peak
3	2412.750	88.55	30.49	119.04	N/A	N/A	100	266	Peak

Note:

1. " \*", means this data is the worst emission level.
2. C.F (Correction Factor) = Antenna Factor (dB/m) + Cable Loss (dB).
3. Measurement (dBUV/m) = Reading(dBUV) + C.F (Correction Factor).
4. The emission levels of other frequencies are very lower than the limit and not show in test report.

EUT	BE11000 Ceiling Mount Wi-Fi 7 Access Point	Date of Test	2024-05-27
Factor	DRH18-E	Temp. / Humidity	20°C /65%
Polarity	Horizontal	Site / Test Engineer	AC2 / You
Test Mode	802.11ax-20MHz_TX_CH 1 ANT 0+1	Test Voltage	AC 120V/60Hz

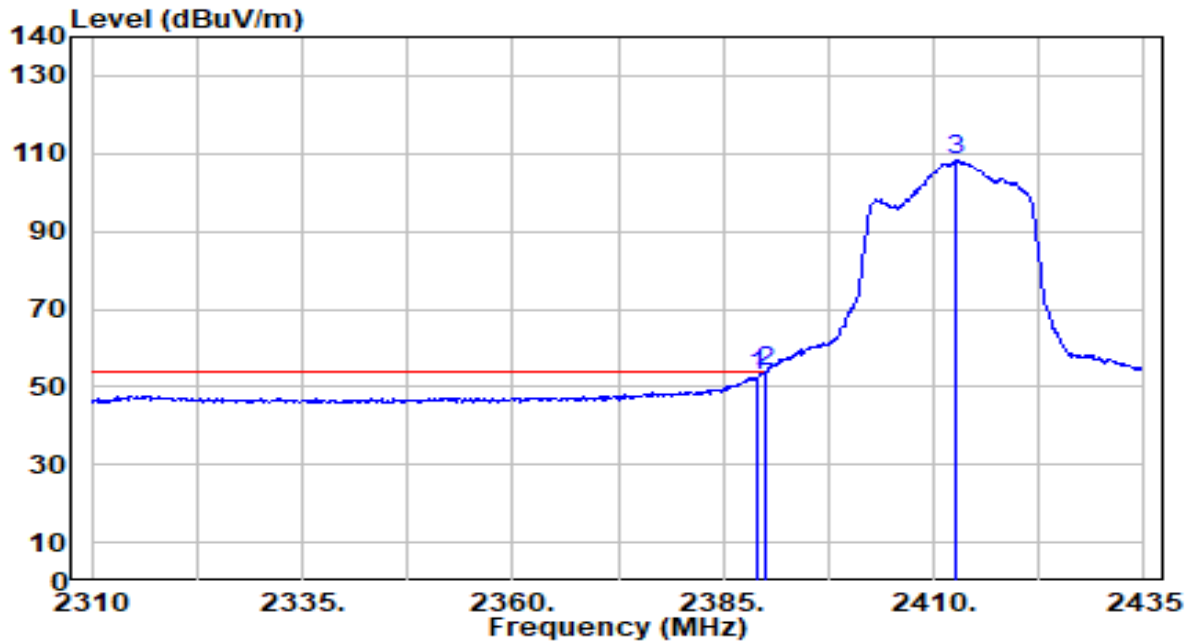

No	Frequency (MHz)	Reading (dBuV)	C.F (dB/m)	Measurement (dBuV/m)	Margin (dB)	Limit (dBuV/m)	Height (cm)	Angle (deg)	Remark (QP/PK/AV)
1	2389.000	22.48	30.44	52.92	-1.08	54.00	100	266	Average
2	* 2390.000	23.19	30.45	53.63	-0.37	54.00	100	266	Average
3	2412.750	77.94	30.49	108.43	N/A	N/A	100	266	Average

Note:

1. " \*", means this data is the worst emission level.
2. C.F (Correction Factor) = Antenna Factor (dB/m) + Cable Loss (dB).
3. Measurement (dBuV/m) = Reading(dBuV) + C.F (Correction Factor).
4. The emission levels of other frequencies are very lower than the limit and not show in test report.

EUT	BE11000 Ceiling Mount Wi-Fi 7 Access Point	Date of Test	2024-05-27
Factor	DRH18-E	Temp. / Humidity	20°C /65%
Polarity	Vertical	Site / Test Engineer	AC2 / You
Test Mode	802.11ax-20MHz_TX_CH 1 ANT 0+1	Test Voltage	AC 120V/60Hz

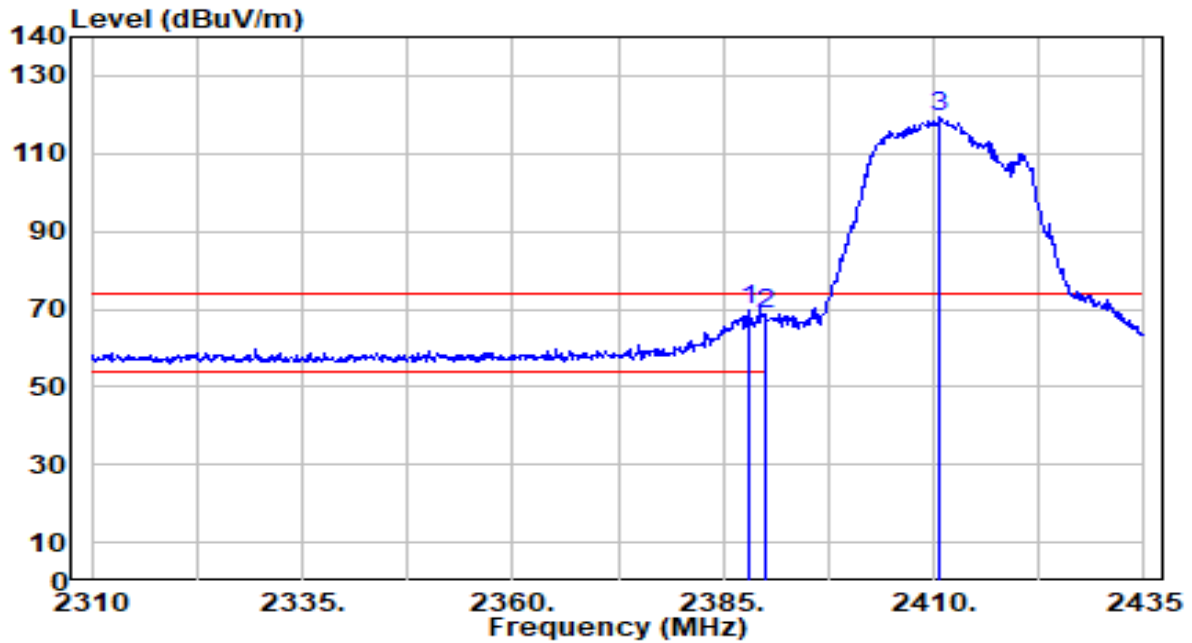

No	Frequency (MHz)	Reading (dBuV)	C.F (dB/m)	Measurement (dBuV/m)	Margin (dB)	Limit (dBuV/m)	Height (cm)	Angle (deg)	Remark (QP/PK/AV)	
1	*	2388.125	39.24	30.44	69.69	-4.31	74.00	168	155	Peak
2		2390.000	38.31	30.45	68.76	-5.24	74.00	168	155	Peak
3		2410.625	88.98	30.49	119.47	N/A	N/A	168	155	Peak

Note:

1. " \*", means this data is the worst emission level.
2. C.F (Correction Factor) = Antenna Factor (dB/m) + Cable Loss (dB).
3. Measurement (dBuV/m) = Reading(dBuV) + C.F (Correction Factor).
4. The emission levels of other frequencies are very lower than the limit and not show in test report.

EUT	BE11000 Ceiling Mount Wi-Fi 7 Access Point	Date of Test	2024-05-27
Factor	DRH18-E	Temp. / Humidity	20°C /65%
Polarity	Vertical	Site / Test Engineer	AC2 / You
Test Mode	802.11ax-20MHz_TX_CH 1 ANT 0+1	Test Voltage	AC 120V/60Hz

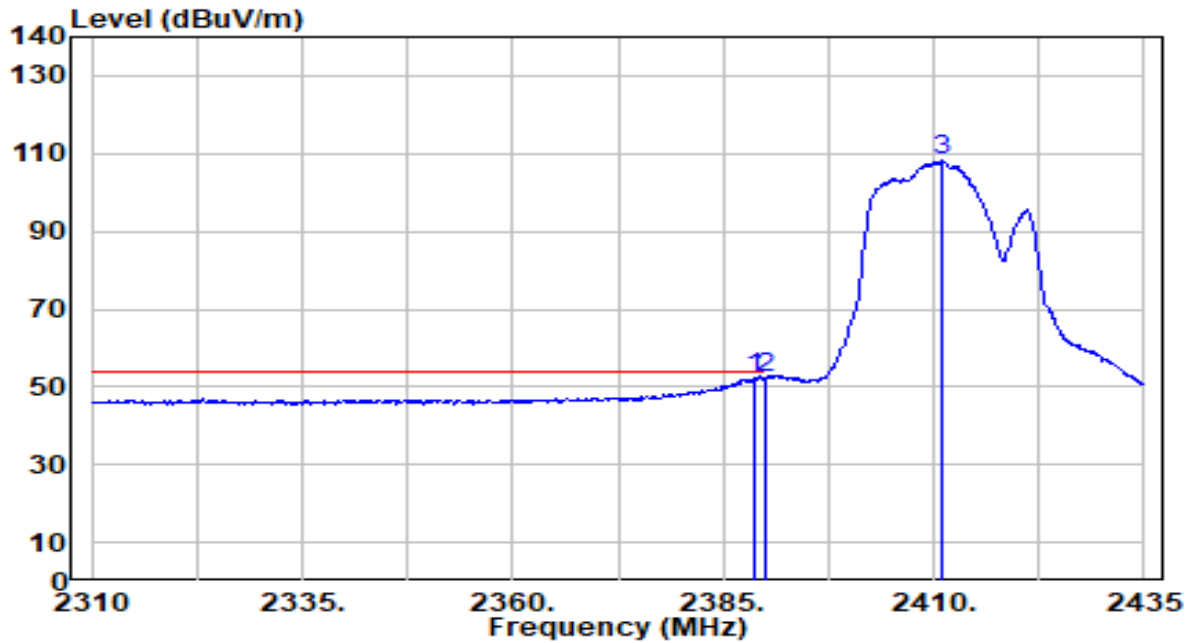

No	Frequency (MHz)	Reading (dBuV)	C.F (dB/m)	Measurement (dBuV/m)	Margin (dB)	Limit (dBuV/m)	Height (cm)	Angle (deg)	Remark (QP/PK/AV)
1	2388.625	22.00	30.44	52.44	-1.56	54.00	168	155	Average
2	* 2390.000	22.10	30.45	52.54	-1.46	54.00	168	155	Average
3	2411.125	77.79	30.49	108.28	N/A	N/A	168	155	Average

Note:

1. " \*", means this data is the worst emission level.
2. C.F (Correction Factor) = Antenna Factor (dB/m) + Cable Loss (dB).
3. Measurement (dBuV/m) = Reading(dBuV) + C.F (Correction Factor).
4. The emission levels of other frequencies are very lower than the limit and not show in test report.

EUT	BE11000 Ceiling Mount Wi-Fi 7 Access Point	Date of Test	2024-05-27
Factor	DRH18-E	Temp. / Humidity	20°C /65%
Polarity	Horizontal	Site / Test Engineer	AC2 / You
Test Mode	802.11ax-20MHz_TX_CH 6 ANT 0+1	Test Voltage	AC 120V/60Hz

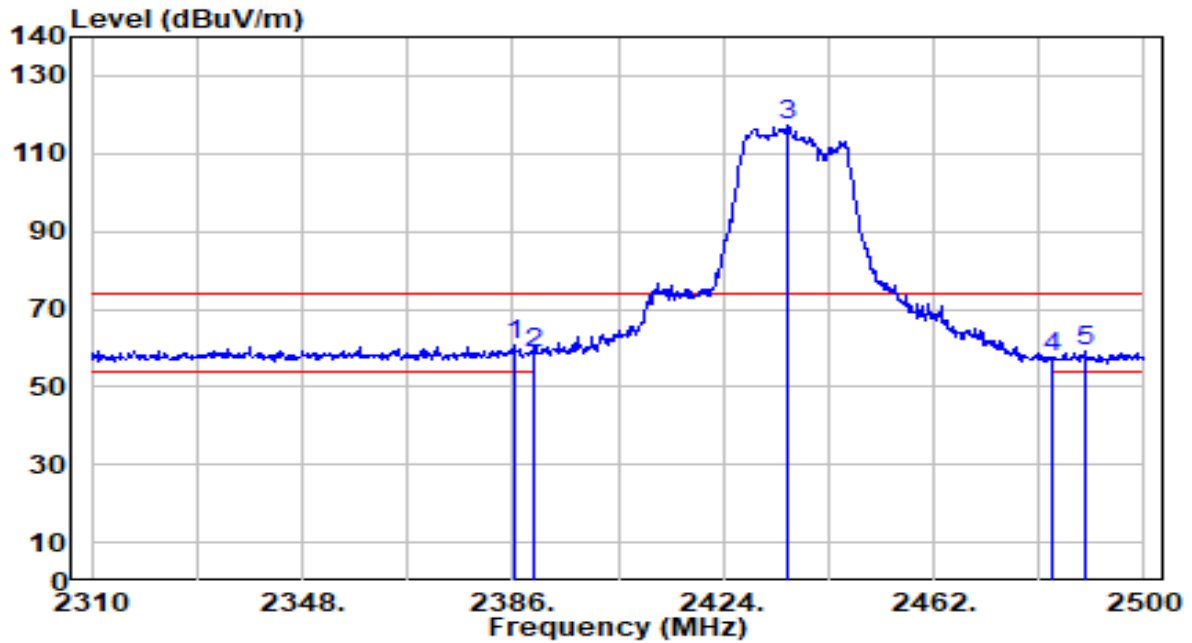

No	Frequency (MHz)	Reading (dBuV)	C.F (dB/m)	Measurement (dBuV/m)	Margin (dB)	Limit (dBuV/m)	Height (cm)	Angle (deg)	Remark (QP/PK/AV)	
1	*	2386.190	30.11	30.44	60.55	-13.45	74.00	100	266	Peak
2		2390.000	28.14	30.45	58.59	-15.41	74.00	100	266	Peak
3		2435.400	86.55	30.52	117.07	N/A	N/A	100	266	Peak
4		2483.500	26.94	30.59	57.53	-16.47	74.00	100	266	Peak
5		2489.170	28.32	30.60	58.92	-15.08	74.00	100	266	Peak

Note:

1. " \*", means this data is the worst emission level.
2. C.F (Correction Factor) = Antenna Factor (dB/m) + Cable Loss (dB).
3. Measurement (dBuV/m) = Reading(dBuV) + C.F (Correction Factor).
4. The emission levels of other frequencies are very lower than the limit and not show in test report.

EUT	BE11000 Ceiling Mount Wi-Fi 7 Access Point	Date of Test	2024-05-27
Factor	DRH18-E	Temp. / Humidity	20°C /65%
Polarity	Horizontal	Site / Test Engineer	AC2 / You
Test Mode	802.11ax-20MHz_TX_CH 6 ANT 0+1	Test Voltage	AC 120V/60Hz

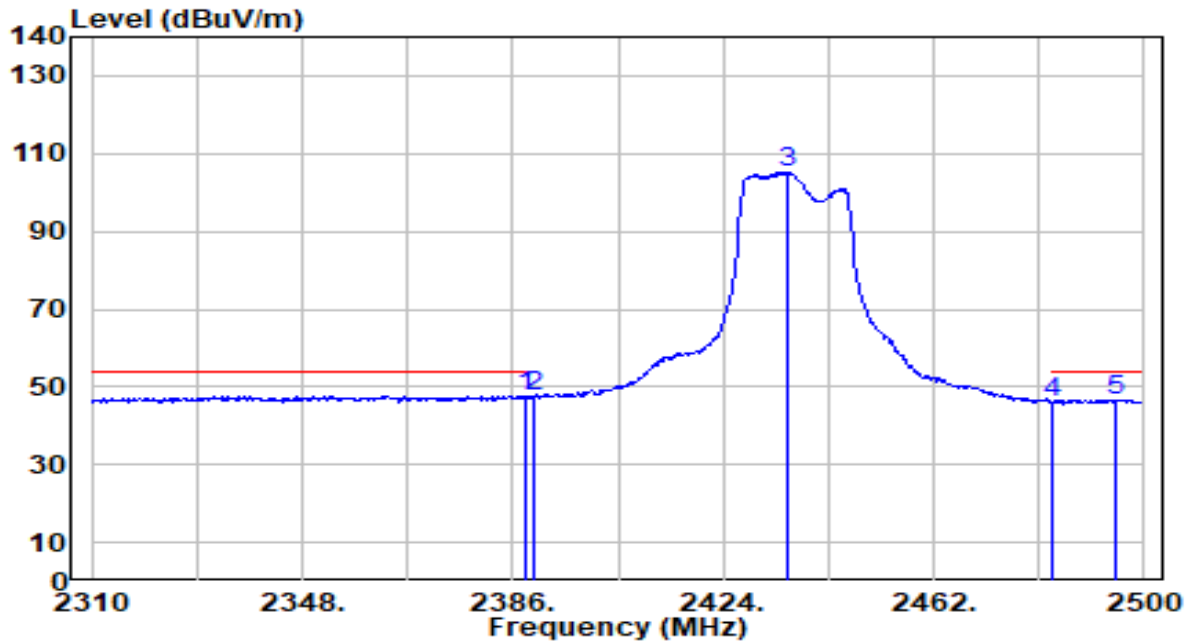

No	Frequency (MHz)	Reading (dBuV)	C.F (dB/m)	Measurement (dBuV/m)	Margin (dB)	Limit (dBuV/m)	Height (cm)	Angle (deg)	Remark (QP/PK/AV)	
1	*	2388.470	17.25	30.44	47.70	-6.30	54.00	100	266	Average
2		2390.000	16.94	30.45	47.39	-6.61	54.00	100	266	Average
3		2435.780	74.82	30.52	105.34	N/A	N/A	100	266	Average
4		2483.500	15.63	30.59	46.21	-7.79	54.00	100	266	Average
5		2494.870	16.09	30.60	46.70	-7.30	54.00	100	266	Average

Note:

1. " \*", means this data is the worst emission level.
2. C.F (Correction Factor) = Antenna Factor (dB/m) + Cable Loss (dB).
3. Measurement (dBuV/m) = Reading(dBuV) + C.F (Correction Factor).
4. The emission levels of other frequencies are very lower than the limit and not show in test report.

EUT	BE11000 Ceiling Mount Wi-Fi 7 Access Point	Date of Test	2024-05-27
Factor	DRH18-E	Temp. / Humidity	20°C /65%
Polarity	Vertical	Site / Test Engineer	AC2 / You
Test Mode	802.11ax-20MHz_TX_CH 6 ANT 0+1	Test Voltage	AC 120V/60Hz

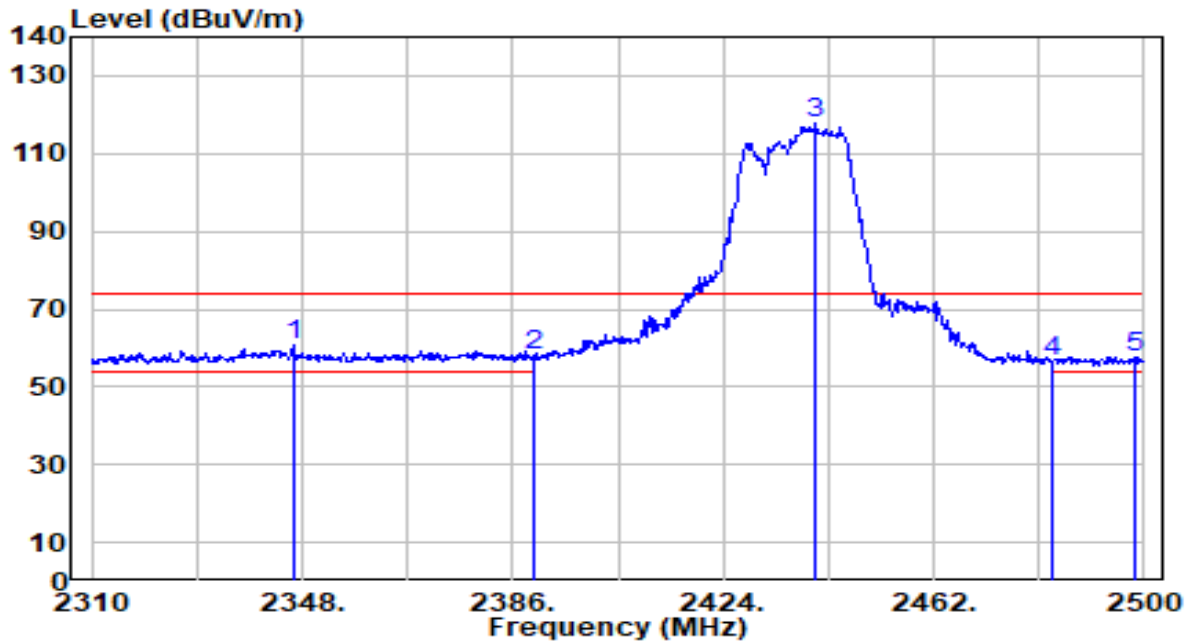

No	Frequency (MHz)	Reading (dBuV)	C.F (dB/m)	Measurement (dBuV/m)	Margin (dB)	Limit (dBuV/m)	Height (cm)	Angle (deg)	Remark (QP/PK/AV)
1	* 2346.290	30.34	30.32	60.66	-13.34	74.00	168	155	Peak
2	2390.000	27.51	30.45	57.96	-16.04	74.00	168	155	Peak
3	2440.530	87.42	30.53	117.95	N/A	N/A	168	155	Peak
4	2483.500	25.68	30.59	56.27	-17.73	74.00	168	155	Peak
5	2498.100	27.22	30.61	57.83	-16.17	74.00	168	155	Peak

Note:

- " \*", means this data is the worst emission level.
- C.F (Correction Factor) = Antenna Factor (dB/m) + Cable Loss (dB).
- Measurement (dBuV/m) = Reading(dBuV) + C.F (Correction Factor).
- The emission levels of other frequencies are very lower than the limit and not show in test report.

EUT	BE11000 Ceiling Mount Wi-Fi 7 Access Point	Date of Test	2024-05-27
Factor	DRH18-E	Temp. / Humidity	20°C /65%
Polarity	Vertical	Site / Test Engineer	AC2 / You
Test Mode	802.11ax-20MHz_TX_CH 6 ANT 0+1	Test Voltage	AC 120V/60Hz

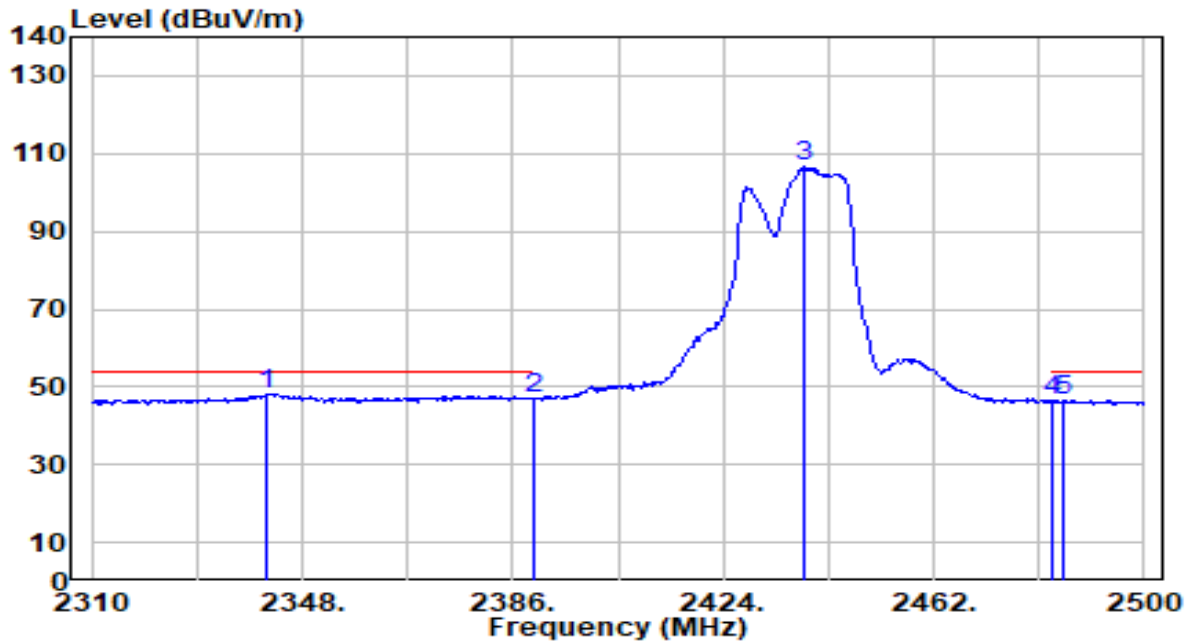

No	Frequency (MHz)	Reading (dBuV)	C.F (dB/m)	Measurement (dBuV/m)	Margin (dB)	Limit (dBuV/m)	Height (cm)	Angle (deg)	Remark (QP/PK/AV)	
1	*	2341.730	17.88	30.31	48.19	-5.81	54.00	168	155	Average
2		2390.000	16.56	30.45	47.01	-6.99	54.00	168	155	Average
3		2438.820	76.07	30.53	106.60	N/A	N/A	168	155	Average
4		2483.500	15.71	30.59	46.30	-7.70	54.00	168	155	Average
5		2485.370	15.99	30.59	46.58	-7.42	54.00	168	155	Average

Note:

- " \*", means this data is the worst emission level.
- C.F (Correction Factor) = Antenna Factor (dB/m) + Cable Loss (dB).
- Measurement (dBuV/m) = Reading(dBuV) + C.F (Correction Factor).
- The emission levels of other frequencies are very lower than the limit and not show in test report.



EUT	BE11000 Ceiling Mount Wi-Fi 7 Access Point	Date of Test	2024-05-27
Factor	DRH18-E	Temp. / Humidity	20°C /65%
Polarity	Horizontal	Site / Test Engineer	AC2 / You
Test Mode	802.11ax-20MHz_TX_CH 11 ANT 0+1	Test Voltage	AC 120V/60Hz

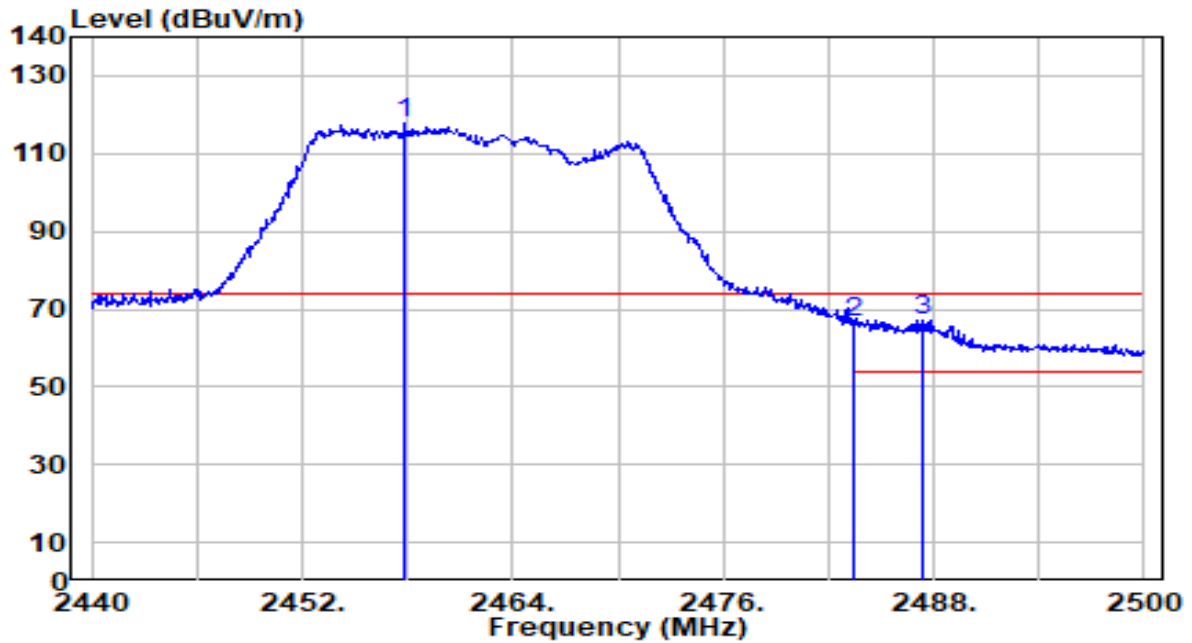

No	Frequency (MHz)	Reading (dBUV)	C.F (dB/m)	Measurement (dBUV/m)	Margin (dB)	Limit (dBUV/m)	Height (cm)	Angle (deg)	Remark (QP/PK/AV)
1	2457.820	87.09	30.55	117.65	N/A	N/A	100	266	Peak
2	2483.500	36.21	30.59	66.80	-7.20	74.00	100	266	Peak
3	* 2487.340	36.51	30.59	67.11	-6.89	74.00	100	266	Peak

Note:

1. " \*", means this data is the worst emission level.
2. C.F (Correction Factor) = Antenna Factor (dB/m) + Cable Loss (dB).
3. Measurement (dBUV/m) = Reading(dBUV) + C.F (Correction Factor).
4. The emission levels of other frequencies are very lower than the limit and not show in test report.

EUT	BE11000 Ceiling Mount Wi-Fi 7 Access Point	Date of Test	2024-05-27
Factor	DRH18-E	Temp. / Humidity	20°C /65%
Polarity	Horizontal	Site / Test Engineer	AC2 / You
Test Mode	802.11ax-20MHz_TX_CH 11 ANT 0+1	Test Voltage	AC 120V/60Hz

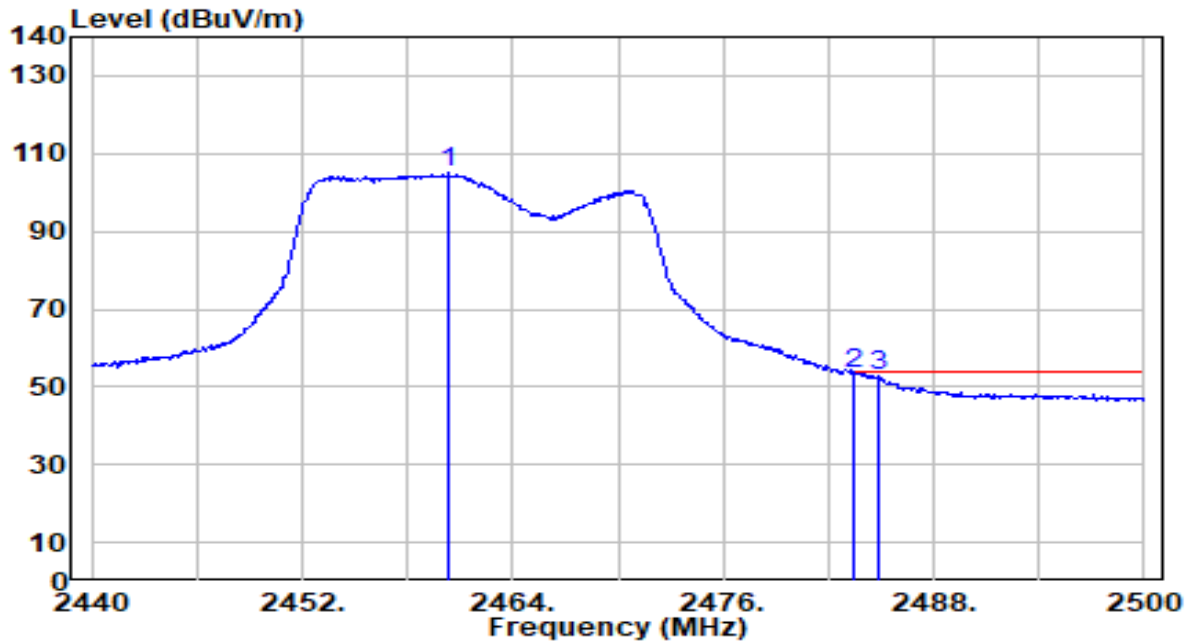

No	Frequency (MHz)	Reading (dBuV)	C.F (dB/m)	Measurement (dBuV/m)	Margin (dB)	Limit (dBuV/m)	Height (cm)	Angle (deg)	Remark (QP/PK/AV)
1	2460.340	74.58	30.56	105.14	N/A	N/A	100	266	Average
2	* 2483.500	23.01	30.59	53.60	-0.40	54.00	100	266	Average
3	2484.820	22.05	30.59	52.64	-1.36	54.00	100	266	Average

Note:

1. " \*", means this data is the worst emission level.
2. C.F (Correction Factor) = Antenna Factor (dB/m) + Cable Loss (dB).
3. Measurement (dBuV/m) = Reading(dBuV) + C.F (Correction Factor).
4. The emission levels of other frequencies are very lower than the limit and not show in test report.

EUT	BE11000 Ceiling Mount Wi-Fi 7 Access Point	Date of Test	2024-05-27
Factor	DRH18-E	Temp. / Humidity	20°C /65%
Polarity	Vertical	Site / Test Engineer	AC2 / You
Test Mode	802.11ax-20MHz_TX_CH 11 ANT 0+1	Test Voltage	AC 120V/60Hz

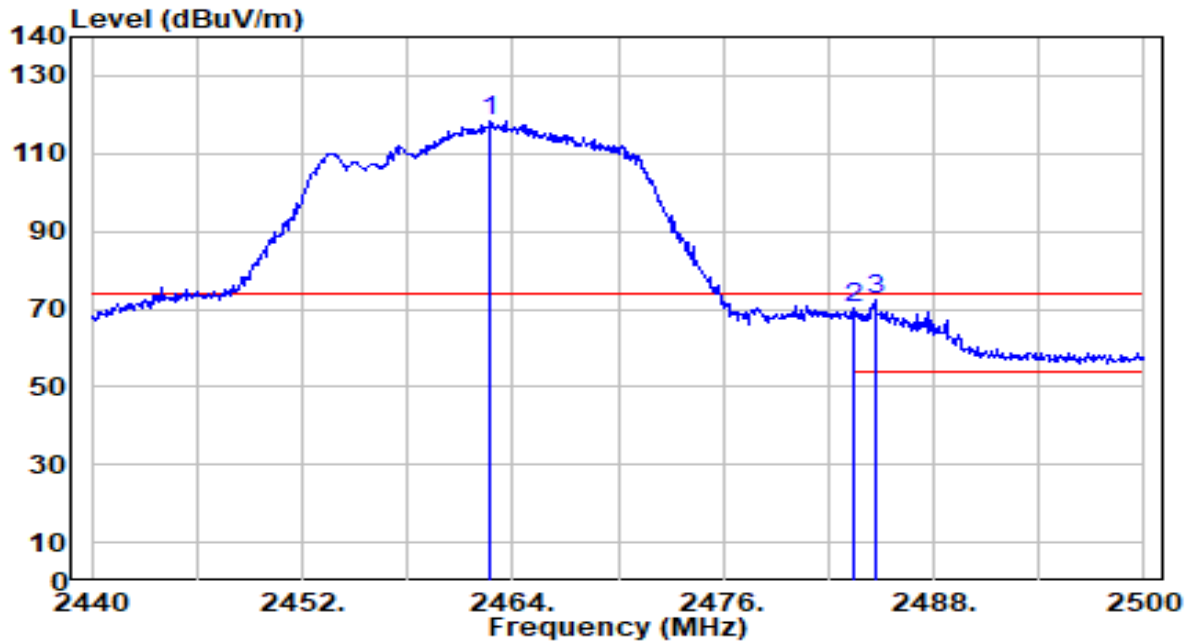

No	Frequency (MHz)	Reading (dBUV)	C.F (dB/m)	Measurement (dBUV/m)	Margin (dB)	Limit (dBUV/m)	Height (cm)	Angle (deg)	Remark (QP/PK/AV)
1	2462.740	87.63	30.56	118.19	N/A	N/A	145	177	Peak
2	2483.500	39.85	30.59	70.43	-3.57	74.00	145	177	Peak
3	* 2484.640	41.78	30.59	72.36	-1.64	74.00	145	177	Peak

Note:

1. " \*", means this data is the worst emission level.
2. C.F (Correction Factor) = Antenna Factor (dB/m) + Cable Loss (dB).
3. Measurement (dBUV/m) = Reading(dBUV) + C.F (Correction Factor).
4. The emission levels of other frequencies are very lower than the limit and not show in test report.

EUT	BE11000 Ceiling Mount Wi-Fi 7 Access Point	Date of Test	2024-05-27
Factor	DRH18-E	Temp. / Humidity	20°C /65%
Polarity	Vertical	Site / Test Engineer	AC2 / You
Test Mode	802.11ax-20MHz_TX_CH 11 ANT 0+1	Test Voltage	AC 120V/60Hz

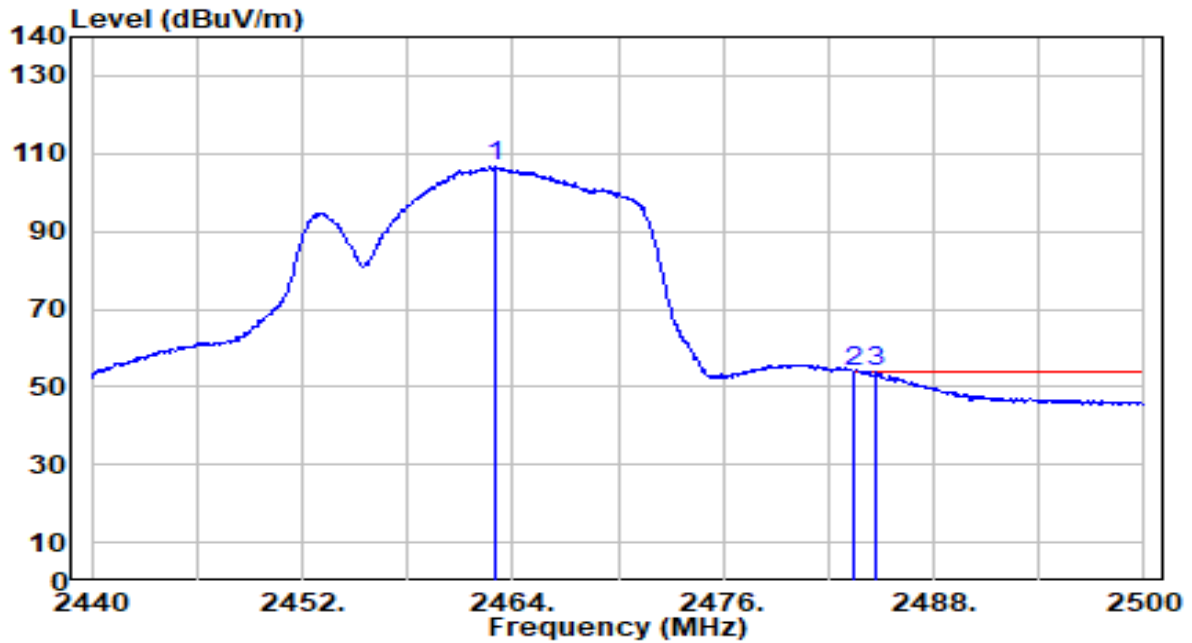

No	Frequency (MHz)	Reading (dBuV)	C.F (dB/m)	Measurement (dBuV/m)	Margin (dB)	Limit (dBuV/m)	Height (cm)	Angle (deg)	Remark (QP/PK/AV)
1	2463.040	75.99	30.56	106.55	N/A	N/A	145	177	Average
2	2483.500	23.14	30.59	53.73	-0.27	54.00	145	177	Average
3	* 2484.760	23.19	30.59	53.78	-0.22	54.00	145	177	Average

Note:

1. " \*", means this data is the worst emission level.
2. C.F (Correction Factor) = Antenna Factor (dB/m) + Cable Loss (dB).
3. Measurement (dBuV/m) = Reading(dBuV) + C.F (Correction Factor).
4. The emission levels of other frequencies are very lower than the limit and not show in test report.

EUT	BE11000 Ceiling Mount Wi-Fi 7 Access Point	Date of Test	2024-05-27
Factor	DRH18-E	Temp. / Humidity	20°C /65%
Polarity	Horizontal	Site / Test Engineer	AC2 / You
Test Mode	802.11ax-40MHz_TX_CH 3 ANT 0+1	Test Voltage	AC 120V/60Hz

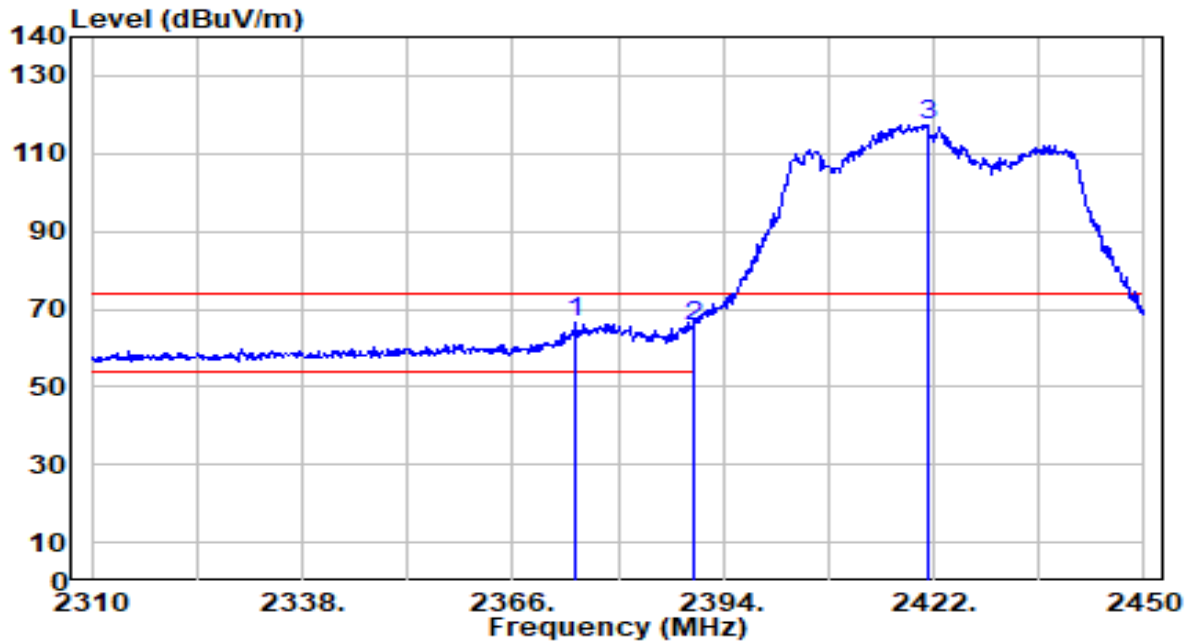

No	Frequency (MHz)	Reading (dBuV)	C.F (dB/m)	Measurement (dBuV/m)	Margin (dB)	Limit (dBuV/m)	Height (cm)	Angle (deg)	Remark (QP/PK/AV)
1	* 2374.400	36.28	30.40	66.69	-7.31	74.00	100	100	Peak
2	2390.000	34.84	30.45	65.29	-8.71	74.00	100	100	Peak
3	2421.160	86.72	30.50	117.22	N/A	N/A	100	100	Peak

Note:

1. " \*", means this data is the worst emission level.
2. C.F (Correction Factor) = Antenna Factor (dB/m) + Cable Loss (dB).
3. Measurement (dBuV/m) = Reading(dBuV) + C.F (Correction Factor).
4. The emission levels of other frequencies are very lower than the limit and not show in test report.

EUT	BE11000 Ceiling Mount Wi-Fi 7 Access Point	Date of Test	2024-05-27
Factor	DRH18-E	Temp. / Humidity	20°C /65%
Polarity	Horizontal	Site / Test Engineer	AC2 / You
Test Mode	802.11ax-40MHz_TX_CH 3 ANT 0+1	Test Voltage	AC 120V/60Hz

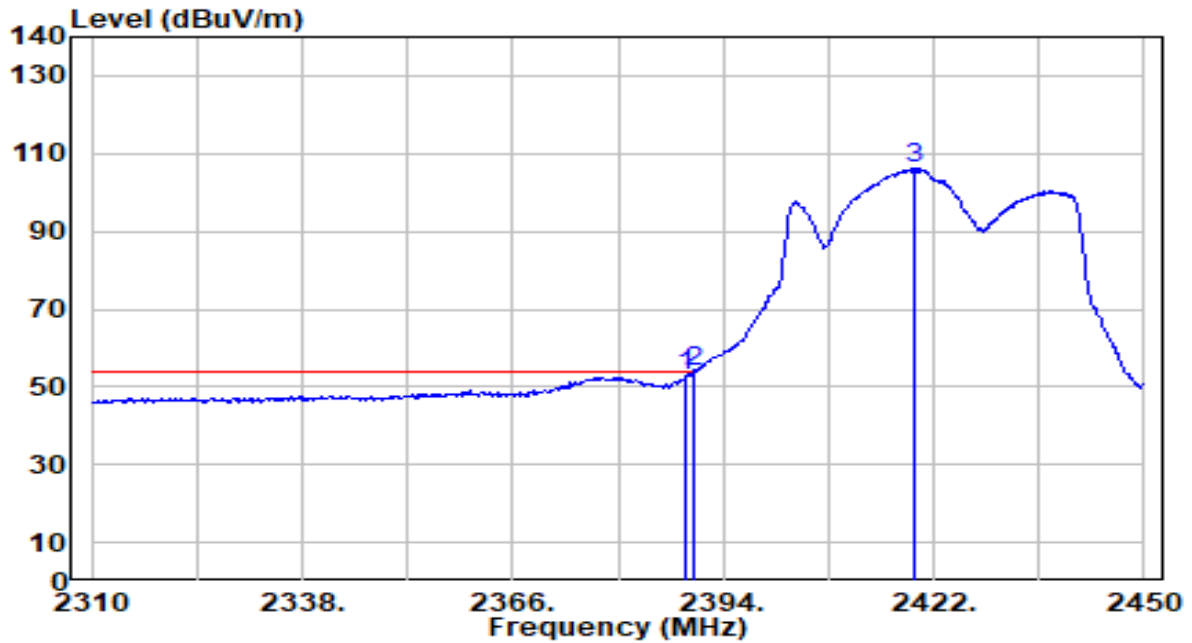

No	Frequency (MHz)	Reading (dBuV)	C.F (dB/m)	Measurement (dBuV/m)	Margin (dB)	Limit (dBuV/m)	Height (cm)	Angle (deg)	Remark (QP/PK/AV)
1	2388.960	22.20	30.44	52.64	-1.36	54.00	100	100	Average
2	* 2390.000	23.39	30.45	53.84	-0.16	54.00	100	100	Average
3	2419.480	75.59	30.50	106.09	N/A	N/A	100	100	Average

Note:

1. " \*", means this data is the worst emission level.
2. C.F (Correction Factor) = Antenna Factor (dB/m) + Cable Loss (dB).
3. Measurement (dBuV/m) = Reading(dBuV) + C.F (Correction Factor).
4. The emission levels of other frequencies are very lower than the limit and not show in test report.

EUT	BE11000 Ceiling Mount Wi-Fi 7 Access Point	Date of Test	2024-05-27
Factor	DRH18-E	Temp. / Humidity	20°C /65%
Polarity	Vertical	Site / Test Engineer	AC2 / You
Test Mode	802.11ax-40MHz_TX_CH 3 ANT 0+1	Test Voltage	AC 120V/60Hz

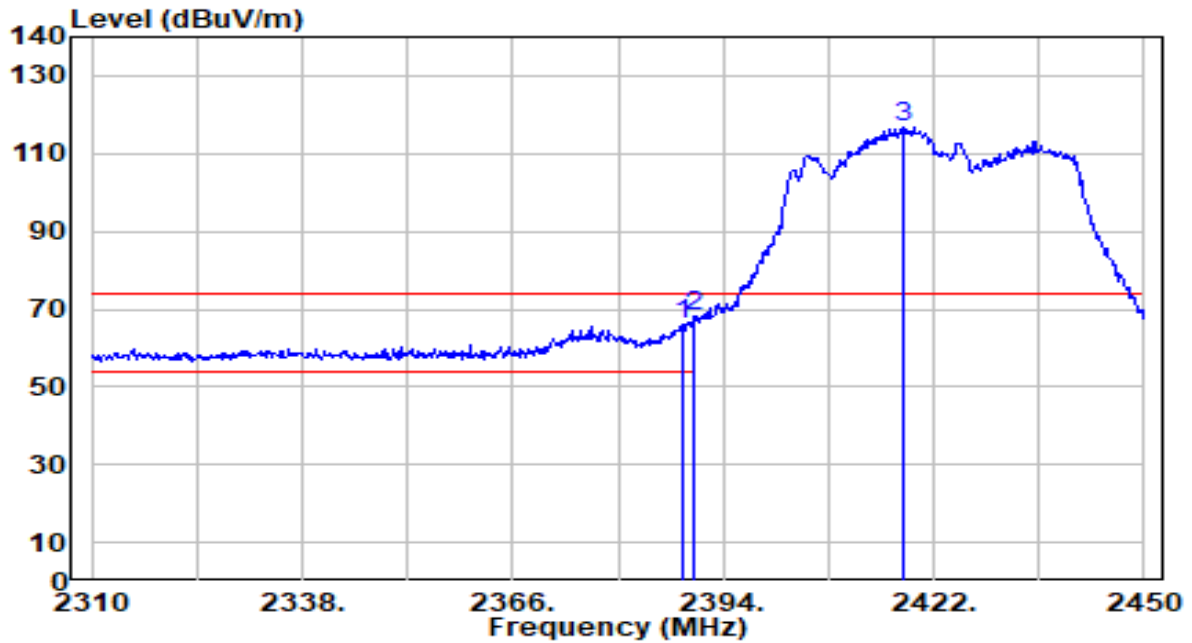

No	Frequency (MHz)	Reading (dBuV)	C.F (dB/m)	Measurement (dBuV/m)	Margin (dB)	Limit (dBuV/m)	Height (cm)	Angle (deg)	Remark (QP/PK/AV)
1	2388.540	35.55	30.44	65.99	-8.01	74.00	212	163	Peak
2	* 2390.000	37.59	30.45	68.04	-5.96	74.00	212	163	Peak
3	2417.940	86.51	30.50	117.01	N/A	N/A	212	163	Peak

Note:

1. " \*", means this data is the worst emission level.
2. C.F (Correction Factor) = Antenna Factor (dB/m) + Cable Loss (dB).
3. Measurement (dBuV/m) = Reading(dBuV) + C.F (Correction Factor).
4. The emission levels of other frequencies are very lower than the limit and not show in test report.

EUT	BE11000 Ceiling Mount Wi-Fi 7 Access Point	Date of Test	2024-05-27
Factor	DRH18-E	Temp. / Humidity	20°C /65%
Polarity	Vertical	Site / Test Engineer	AC2 / You
Test Mode	802.11ax-40MHz_TX_CH 3 ANT 0+1	Test Voltage	AC 120V/60Hz

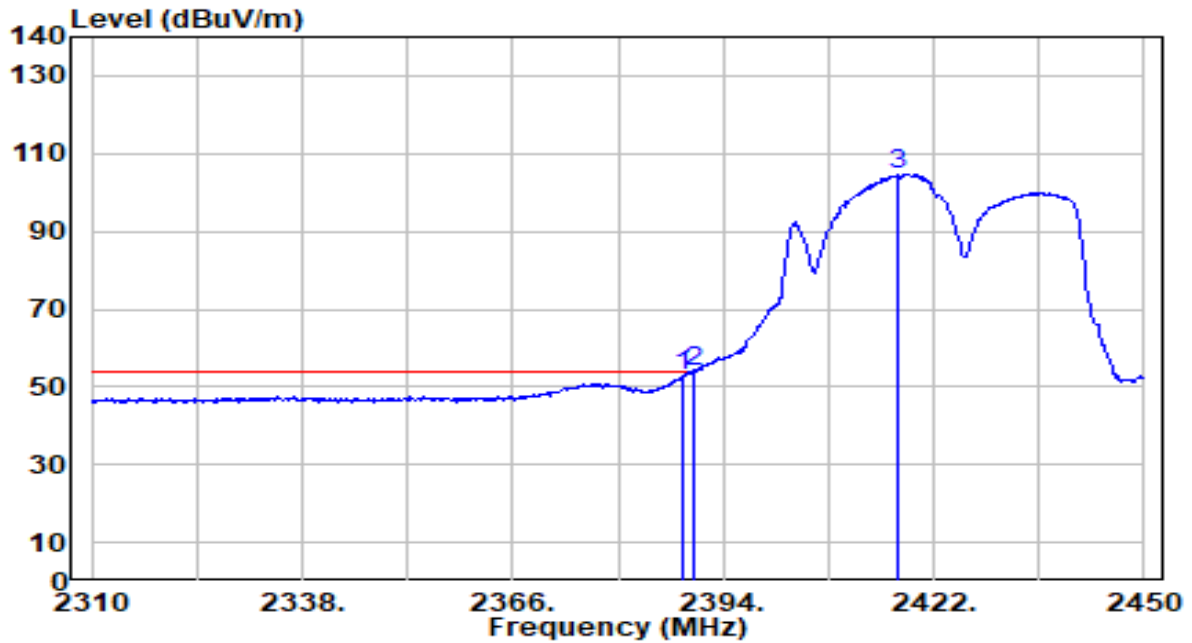

No	Frequency (MHz)	Reading (dBuV)	C.F (dB/m)	Measurement (dBuV/m)	Margin (dB)	Limit (dBuV/m)	Height (cm)	Angle (deg)	Remark (QP/PK/AV)
1	2388.680	22.47	30.44	52.91	-1.09	54.00	212	163	Average
2	* 2390.000	23.40	30.45	53.85	-0.15	54.00	212	163	Average
3	2417.240	74.01	30.50	104.51	N/A	N/A	212	163	Average

Note:

1. " \*", means this data is the worst emission level.
2. C.F (Correction Factor) = Antenna Factor (dB/m) + Cable Loss (dB).
3. Measurement (dBuV/m) = Reading(dBuV) + C.F (Correction Factor).
4. The emission levels of other frequencies are very lower than the limit and not show in test report.



EUT	BE11000 Ceiling Mount Wi-Fi 7 Access Point	Date of Test	2024-05-27
Factor	DRH18-E	Temp. / Humidity	20°C /65%
Polarity	Horizontal	Site / Test Engineer	AC2 / You
Test Mode	802.11ax-40MHz_TX_CH 6 ANT 0+1	Test Voltage	AC 120V/60Hz

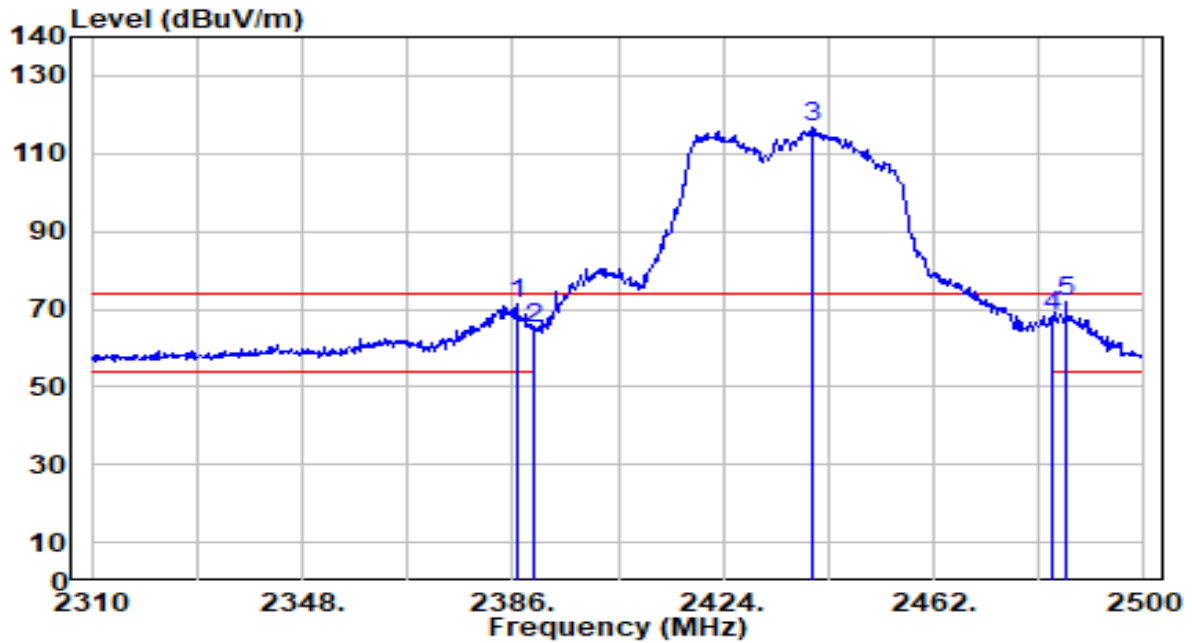

No	Frequency (MHz)	Reading (dBuV)	C.F (dB/m)	Measurement (dBuV/m)	Margin (dB)	Limit (dBuV/m)	Height (cm)	Angle (deg)	Remark (QP/PK/AV)
1	2386.760	40.96	30.44	71.40	-2.60	74.00	100	100	Peak
2	2390.000	34.74	30.45	65.18	-8.82	74.00	100	100	Peak
3	2440.150	86.44	30.53	116.97	N/A	N/A	100	100	Peak
4	2483.500	37.82	30.59	68.40	-5.60	74.00	100	100	Peak
5	* 2485.940	41.05	30.59	71.64	-2.36	74.00	100	100	Peak

Note:

1. " \*", means this data is the worst emission level.
2. C.F (Correction Factor) = Antenna Factor (dB/m) + Cable Loss (dB).
3. Measurement (dBuV/m) = Reading(dBuV) + C.F (Correction Factor).
4. The emission levels of other frequencies are very lower than the limit and not show in test report.

EUT	BE11000 Ceiling Mount Wi-Fi 7 Access Point	Date of Test	2024-05-27
Factor	DRH18-E	Temp. / Humidity	20°C /65%
Polarity	Horizontal	Site / Test Engineer	AC2 / You
Test Mode	802.11ax-40MHz_TX_CH 6 ANT 0+1	Test Voltage	AC 120V/60Hz

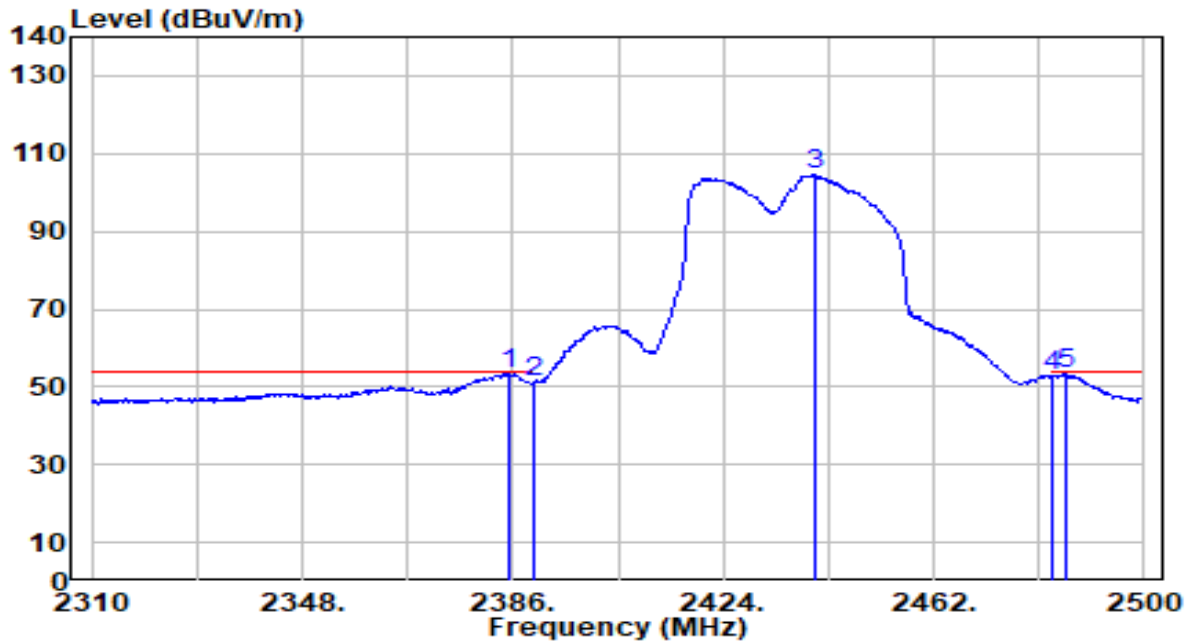

No	Frequency (MHz)	Reading (dBuV)	C.F (dB/m)	Measurement (dBuV/m)	Margin (dB)	Limit (dBuV/m)	Height (cm)	Angle (deg)	Remark (QP/PK/AV)
1	2385.240	22.87	30.43	53.30	-0.70	54.00	100	100	Average
2	2390.000	20.98	30.45	51.43	-2.57	54.00	100	100	Average
3	2440.530	73.96	30.53	104.49	N/A	N/A	100	100	Average
4	2483.500	22.36	30.59	52.95	-1.05	54.00	100	100	Average
5	* 2485.940	22.76	30.59	53.35	-0.65	54.00	100	100	Average

Note:

1. " \*", means this data is the worst emission level.
2. C.F (Correction Factor) = Antenna Factor (dB/m) + Cable Loss (dB).
3. Measurement (dBuV/m) = Reading(dBuV) + C.F (Correction Factor).
4. The emission levels of other frequencies are very lower than the limit and not show in test report.

EUT	BE11000 Ceiling Mount Wi-Fi 7 Access Point	Date of Test	2024-05-27
Factor	DRH18-E	Temp. / Humidity	20°C /65%
Polarity	Vertical	Site / Test Engineer	AC2 / You
Test Mode	802.11ax-40MHz_TX_CH 6 ANT 0+1	Test Voltage	AC 120V/60Hz

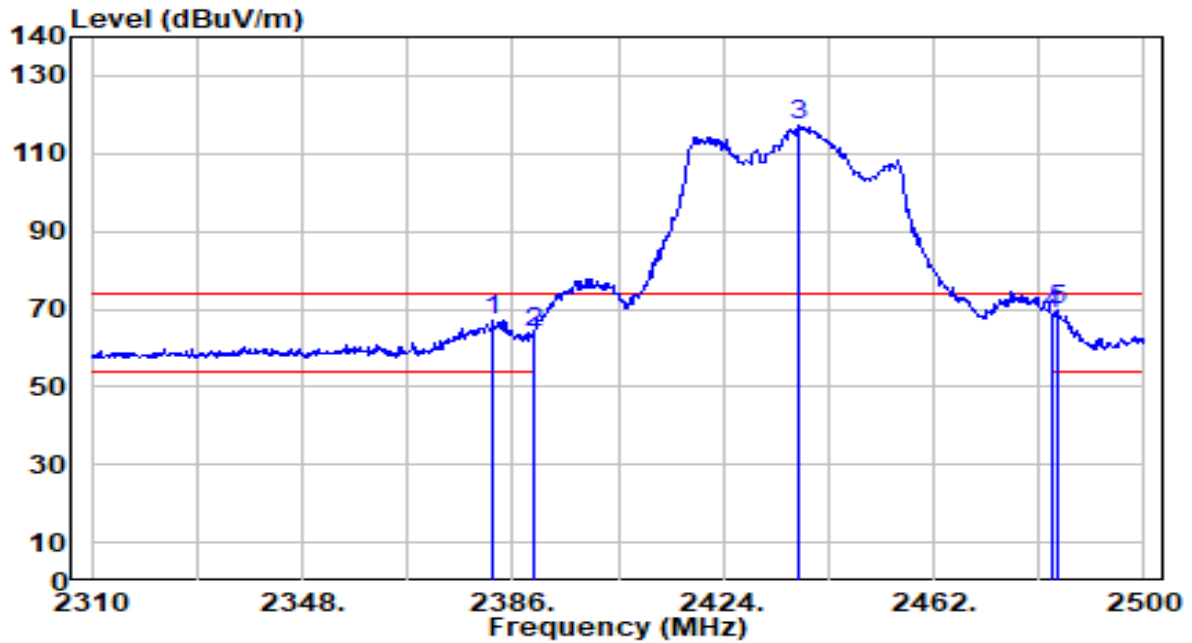

No	Frequency (MHz)	Reading (dBuV)	C.F (dB/m)	Measurement (dBuV/m)	Margin (dB)	Limit (dBuV/m)	Height (cm)	Angle (deg)	Remark (QP/PK/AV)
1	2382.390	36.78	30.43	67.21	-6.79	74.00	214	168	Peak
2	2390.000	33.30	30.45	63.75	-10.25	74.00	214	168	Peak
3	2437.490	86.96	30.53	117.49	N/A	N/A	214	168	Peak
4	2483.500	38.32	30.59	68.91	-5.09	74.00	214	168	Peak
5	* 2484.420	39.13	30.59	69.72	-4.28	74.00	214	168	Peak

Note:

1. " \*", means this data is the worst emission level.
2. C.F (Correction Factor) = Antenna Factor (dB/m) + Cable Loss (dB).
3. Measurement (dBuV/m) = Reading(dBuV) + C.F (Correction Factor).
4. The emission levels of other frequencies are very lower than the limit and not show in test report.

EUT	BE11000 Ceiling Mount Wi-Fi 7 Access Point	Date of Test	2024-05-27
Factor	DRH18-E	Temp. / Humidity	20°C /65%
Polarity	Vertical	Site / Test Engineer	AC2 / You
Test Mode	802.11ax-40MHz_TX_CH 6 ANT 0+1	Test Voltage	AC 120V/60Hz

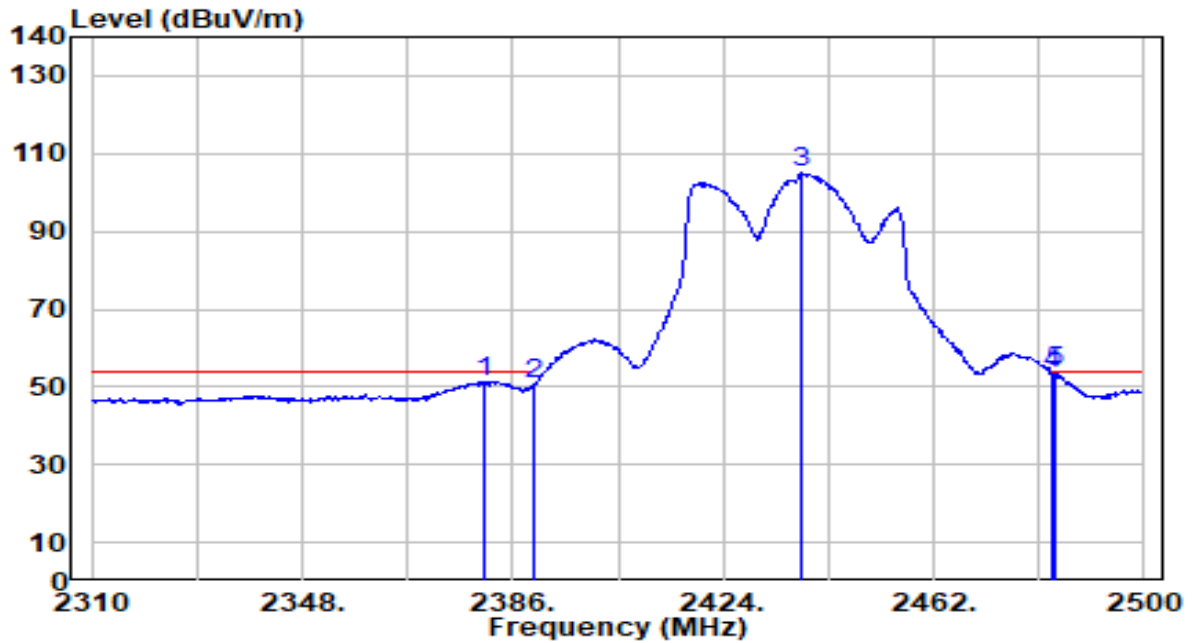

No	Frequency (MHz)	Reading (dBuV)	C.F (dB/m)	Measurement (dBuV/m)	Margin (dB)	Limit (dBuV/m)	Height (cm)	Angle (deg)	Remark (QP/PK/AV)
1	2380.870	20.86	30.42	51.28	-2.72	54.00	214	168	Average
2	2390.000	20.43	30.45	50.88	-3.12	54.00	214	168	Average
3	2438.060	74.45	30.53	104.97	N/A	N/A	214	168	Average
4	2483.500	22.95	30.59	53.54	-0.46	54.00	214	168	Average
5	* 2484.040	23.09	30.59	53.68	-0.32	54.00	214	168	Average

Note:

1. " \*", means this data is the worst emission level.
2. C.F (Correction Factor) = Antenna Factor (dB/m) + Cable Loss (dB).
3. Measurement (dBuV/m) = Reading(dBuV) + C.F (Correction Factor).
4. The emission levels of other frequencies are very lower than the limit and not show in test report.

EUT	BE11000 Ceiling Mount Wi-Fi 7 Access Point	Date of Test	2024-05-27
Factor	DRH18-E	Temp. / Humidity	20°C /65%
Polarity	Horizontal	Site / Test Engineer	AC2 / You
Test Mode	802.11ax-40MHz_TX_CH 9 ANT 0+1	Test Voltage	AC 120V/60Hz

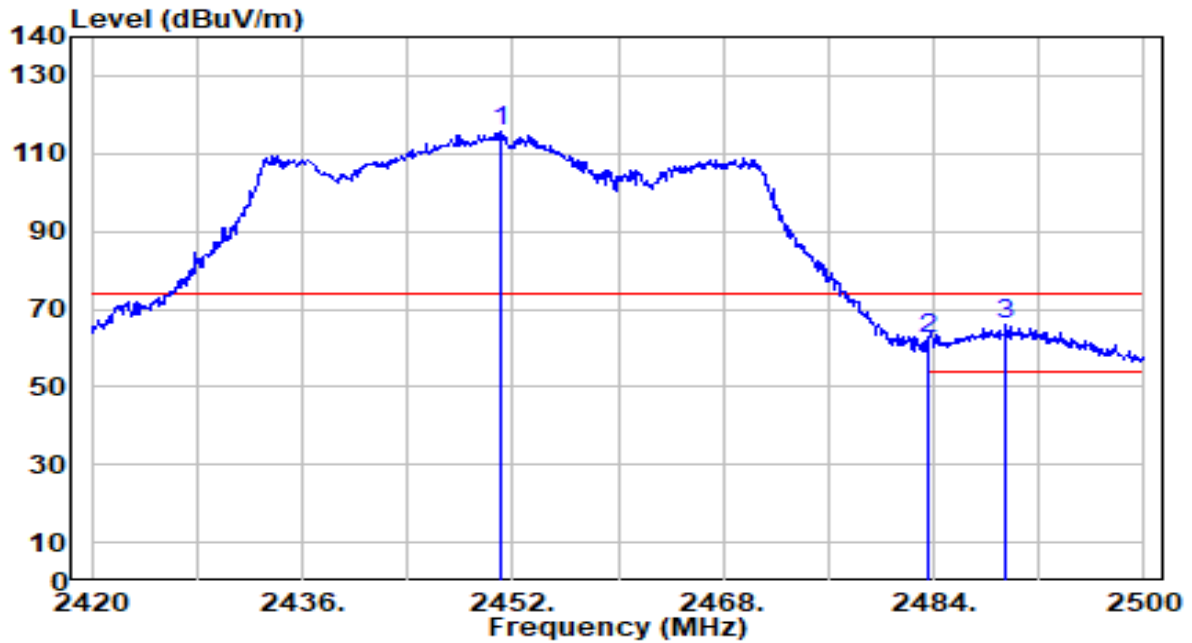

No	Frequency (MHz)	Reading (dBuV)	C.F (dB/m)	Measurement (dBuV/m)	Margin (dB)	Limit (dBuV/m)	Height (cm)	Angle (deg)	Remark (QP/PK/AV)
1	2451.040	85.11	30.54	115.66	N/A	N/A	100	101	Peak
2	2483.500	31.57	30.59	62.16	-11.84	74.00	100	101	Peak
3	* 2489.520	35.43	30.60	66.03	-7.97	74.00	100	101	Peak

Note:

1. " \*", means this data is the worst emission level.
2. C.F (Correction Factor) = Antenna Factor (dB/m) + Cable Loss (dB).
3. Measurement (dBuV/m) = Reading(dBuV) + C.F (Correction Factor).
4. The emission levels of other frequencies are very lower than the limit and not show in test report.

EUT	BE11000 Ceiling Mount Wi-Fi 7 Access Point	Date of Test	2024-05-27
Factor	DRH18-E	Temp. / Humidity	20°C /65%
Polarity	Horizontal	Site / Test Engineer	AC2 / You
Test Mode	802.11ax-40MHz_TX_CH 9 ANT 0+1	Test Voltage	AC 120V/60Hz

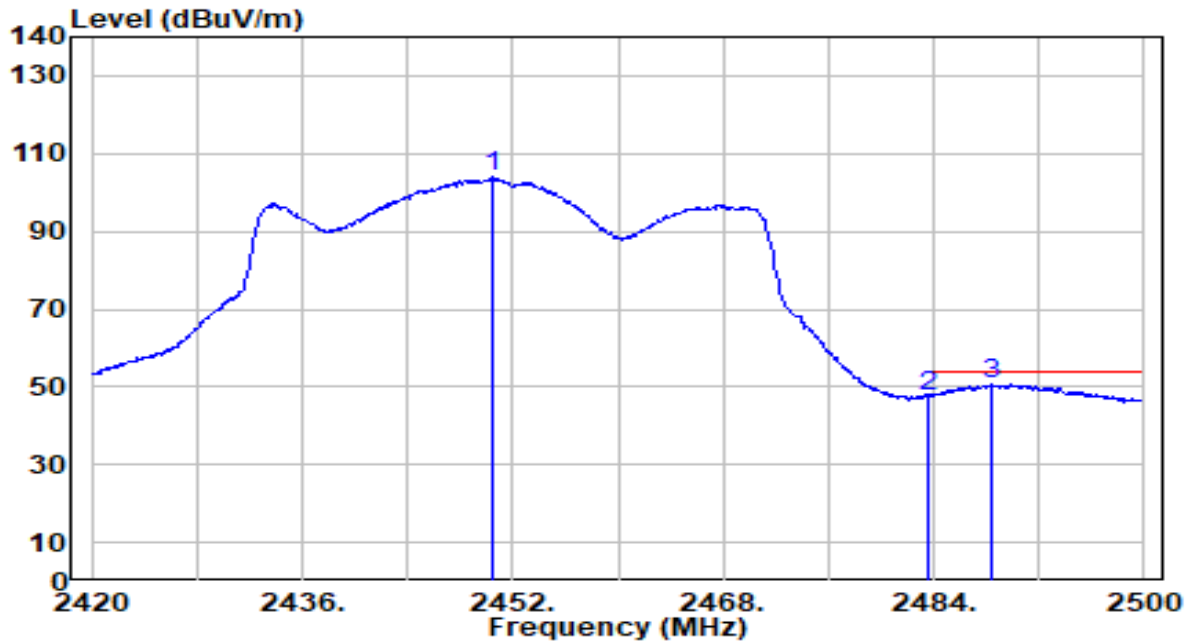

No	Frequency (MHz)	Reading (dBuV)	C.F (dB/m)	Measurement (dBuV/m)	Margin (dB)	Limit (dBuV/m)	Height (cm)	Angle (deg)	Remark (QP/PK/AV)
1	2450.560	73.29	30.54	103.83	N/A	N/A	100	101	Average
2	2483.500	16.87	30.59	47.46	-6.54	54.00	100	101	Average
3	* 2488.320	20.10	30.59	50.70	-3.30	54.00	100	101	Average

Note:

1. " \*", means this data is the worst emission level.
2. C.F (Correction Factor) = Antenna Factor (dB/m) + Cable Loss (dB).
3. Measurement (dBuV/m) = Reading(dBuV) + C.F (Correction Factor).
4. The emission levels of other frequencies are very lower than the limit and not show in test report.

EUT	BE11000 Ceiling Mount Wi-Fi 7 Access Point	Date of Test	2024-05-27
Factor	DRH18-E	Temp. / Humidity	20°C /65%
Polarity	Vertical	Site / Test Engineer	AC2 / You
Test Mode	802.11ax-40MHz_TX_CH 9 ANT 0+1	Test Voltage	AC 120V/60Hz

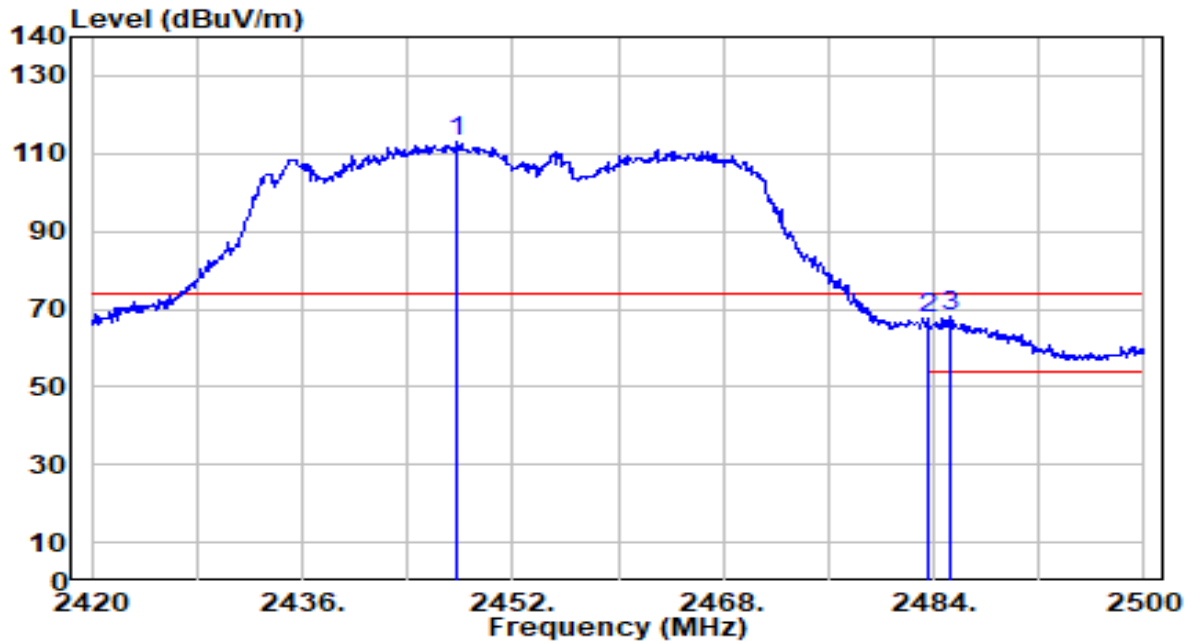

No	Frequency (MHz)	Reading (dBuV)	C.F (dB/m)	Measurement (dBuV/m)	Margin (dB)	Limit (dBuV/m)	Height (cm)	Angle (deg)	Remark (QP/PK/AV)
1	2447.760	82.34	30.54	112.88	N/A	N/A	214	168	Peak
2	2483.500	37.10	30.59	67.69	-6.31	74.00	214	168	Peak
3	* 2485.280	37.40	30.59	67.99	-6.01	74.00	214	168	Peak

Note:

1. " \*", means this data is the worst emission level.
2. C.F (Correction Factor) = Antenna Factor (dB/m) + Cable Loss (dB).
3. Measurement (dBuV/m) = Reading(dBuV) + C.F (Correction Factor).
4. The emission levels of other frequencies are very lower than the limit and not show in test report.

EUT	BE11000 Ceiling Mount Wi-Fi 7 Access Point	Date of Test	2024-05-27
Factor	DRH18-E	Temp. / Humidity	20°C /65%
Polarity	Vertical	Site / Test Engineer	AC2 / You
Test Mode	802.11ax-40MHz_TX_CH 9 ANT 0+1	Test Voltage	AC 120V/60Hz

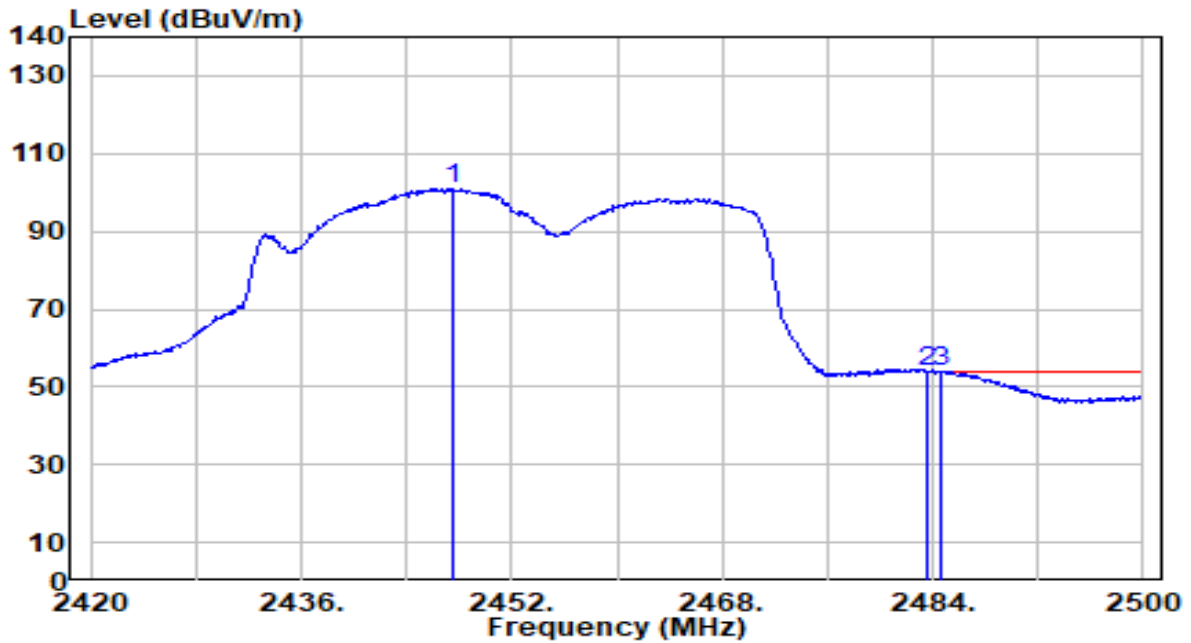

No	Frequency (MHz)	Reading (dBuV)	C.F (dB/m)	Measurement (dBuV/m)	Margin (dB)	Limit (dBuV/m)	Height (cm)	Angle (deg)	Remark (QP/PK/AV)
1	2447.600	70.56	30.54	101.10	N/A	N/A	214	168	Average
2	2483.500	23.34	30.59	53.93	-0.07	54.00	214	168	Average
3	* 2484.640	23.34	30.59	53.93	-0.07	54.00	214	168	Average

Note:

1. " \*", means this data is the worst emission level.
2. C.F (Correction Factor) = Antenna Factor (dB/m) + Cable Loss (dB).
3. Measurement (dBuV/m) = Reading(dBuV) + C.F (Correction Factor).
4. The emission levels of other frequencies are very lower than the limit and not show in test report.



EUT	BE11000 Ceiling Mount Wi-Fi 7 Access Point	Date of Test	2024-05-27
Factor	DRH18-E	Temp. / Humidity	20°C /65%
Polarity	Horizontal	Site / Test Engineer	AC2 / You
Test Mode	802.11be-20MHz_TX_CH 1 ANT 0+1	Test Voltage	AC 120V/60Hz

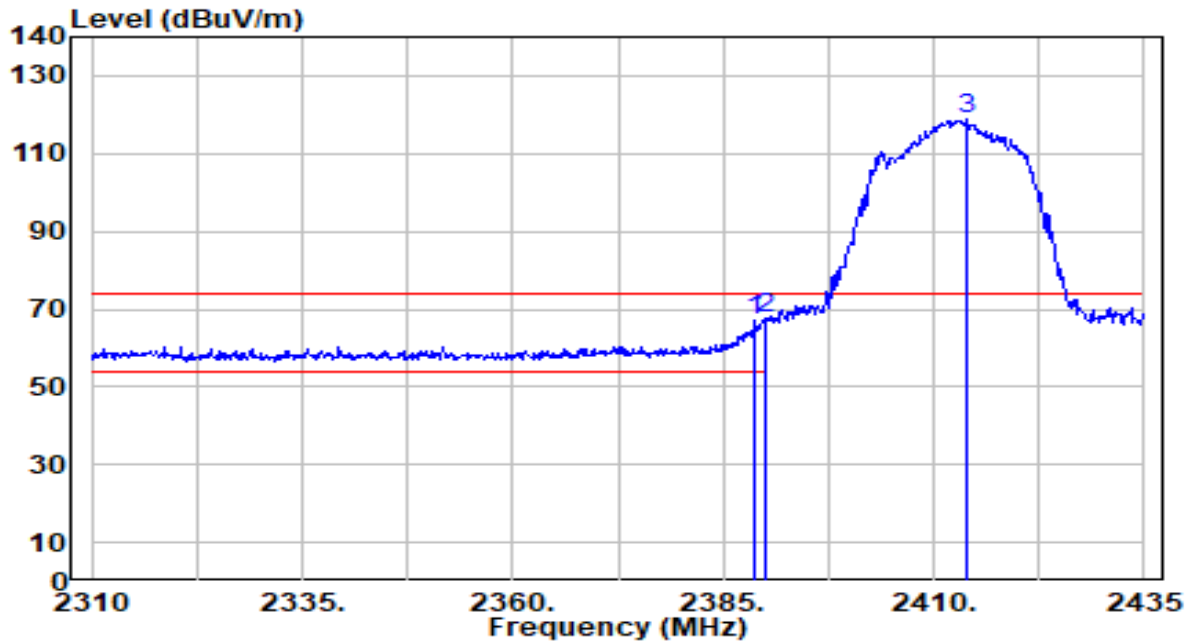

No	Frequency (MHz)	Reading (dBuV)	C.F (dB/m)	Measurement (dBuV/m)	Margin (dB)	Limit (dBuV/m)	Height (cm)	Angle (deg)	Remark (QP/PK/AV)
1	2388.750	36.56	30.44	67.00	-7.00	74.00	182	267	Peak
2	* 2390.000	37.01	30.45	67.46	-6.54	74.00	182	267	Peak
3	2413.875	88.29	30.49	118.78	N/A	N/A	182	267	Peak

Note:

1. " \*", means this data is the worst emission level.
2. C.F (Correction Factor) = Antenna Factor (dB/m) + Cable Loss (dB).
3. Measurement (dBuV/m) = Reading(dBuV) + C.F (Correction Factor).
4. The emission levels of other frequencies are very lower than the limit and not show in test report.

EUT	BE11000 Ceiling Mount Wi-Fi 7 Access Point	Date of Test	2024-05-27
Factor	DRH18-E	Temp. / Humidity	20°C /65%
Polarity	Horizontal	Site / Test Engineer	AC2 / You
Test Mode	802.11be-20MHz_TX_CH 1 ANT 0+1	Test Voltage	AC 120V/60Hz

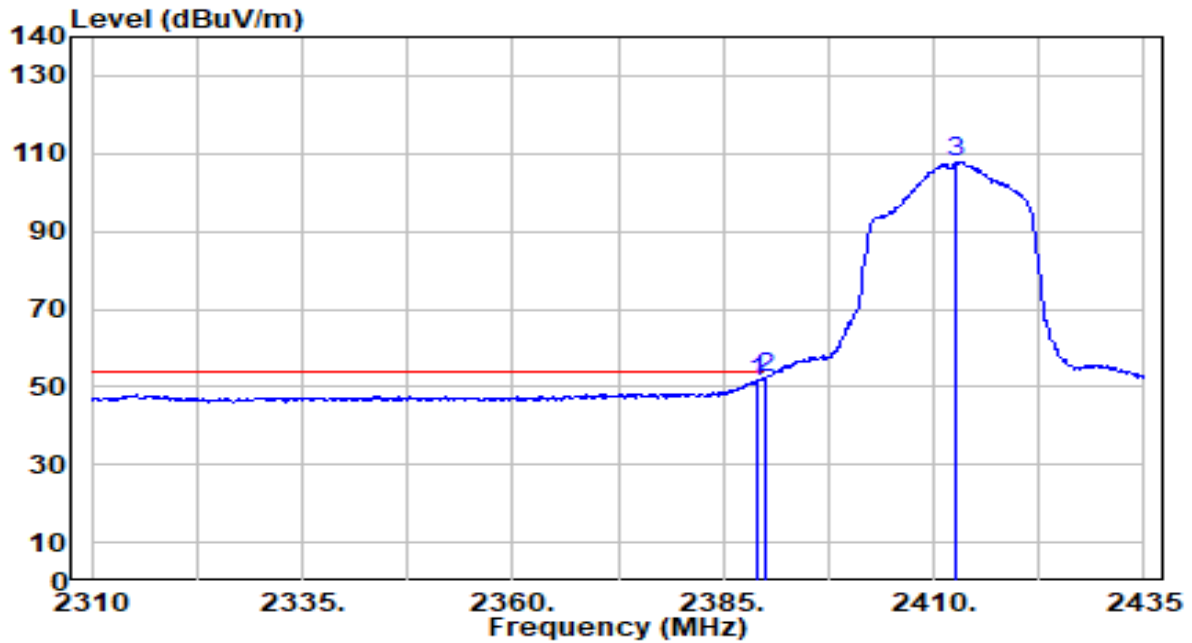

No	Frequency (MHz)	Reading (dBuV)	C.F (dB/m)	Measurement (dBuV/m)	Margin (dB)	Limit (dBuV/m)	Height (cm)	Angle (deg)	Remark (QP/PK/AV)
1	2389.000	21.01	30.44	51.46	-2.54	54.00	182	267	Average
2	* 2390.000	21.80	30.45	52.25	-1.75	54.00	182	267	Average
3	2412.750	77.33	30.49	107.82	N/A	N/A	182	267	Average

Note:

1. " \*", means this data is the worst emission level.
2. C.F (Correction Factor) = Antenna Factor (dB/m) + Cable Loss (dB).
3. Measurement (dBuV/m) = Reading(dBuV) + C.F (Correction Factor).
4. The emission levels of other frequencies are very lower than the limit and not show in test report.

EUT	BE11000 Ceiling Mount Wi-Fi 7 Access Point	Date of Test	2024-05-27
Factor	DRH18-E	Temp. / Humidity	20°C /65%
Polarity	Vertical	Site / Test Engineer	AC2 / You
Test Mode	802.11be-20MHz_TX_CH 1 ANT 0+1	Test Voltage	AC 120V/60Hz

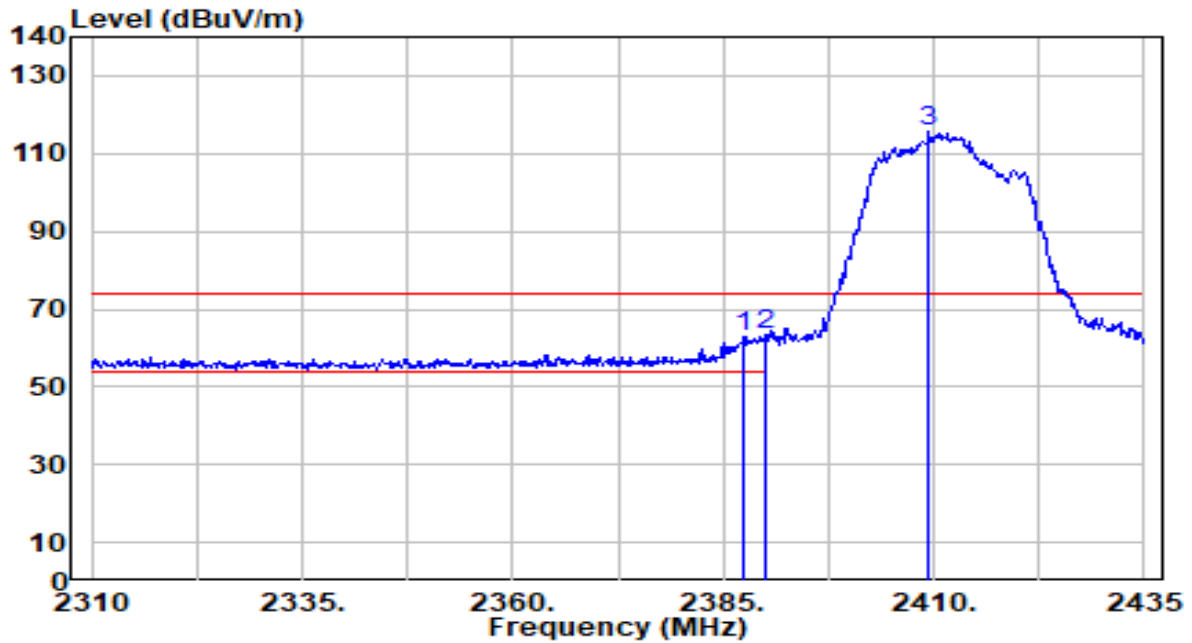

No	Frequency (MHz)	Reading (dBuV)	C.F (dB/m)	Measurement (dBuV/m)	Margin (dB)	Limit (dBuV/m)	Height (cm)	Angle (deg)	Remark (QP/PK/AV)
1	2387.500	32.67	30.44	63.11	-10.89	74.00	100	154	Peak
2	* 2390.000	32.90	30.45	63.35	-10.65	74.00	100	154	Peak
3	2409.500	85.05	30.49	115.54	N/A	N/A	100	154	Peak

Note:

1. " \*", means this data is the worst emission level.
2. C.F (Correction Factor) = Antenna Factor (dB/m) + Cable Loss (dB).
3. Measurement (dBuV/m) = Reading(dBuV) + C.F (Correction Factor).
4. The emission levels of other frequencies are very lower than the limit and not show in test report.

EUT	BE11000 Ceiling Mount Wi-Fi 7 Access Point	Date of Test	2024-05-27
Factor	DRH18-E	Temp. / Humidity	20°C /65%
Polarity	Vertical	Site / Test Engineer	AC2 / You
Test Mode	802.11be-20MHz_TX_CH 1 ANT 0+1	Test Voltage	AC 120V/60Hz

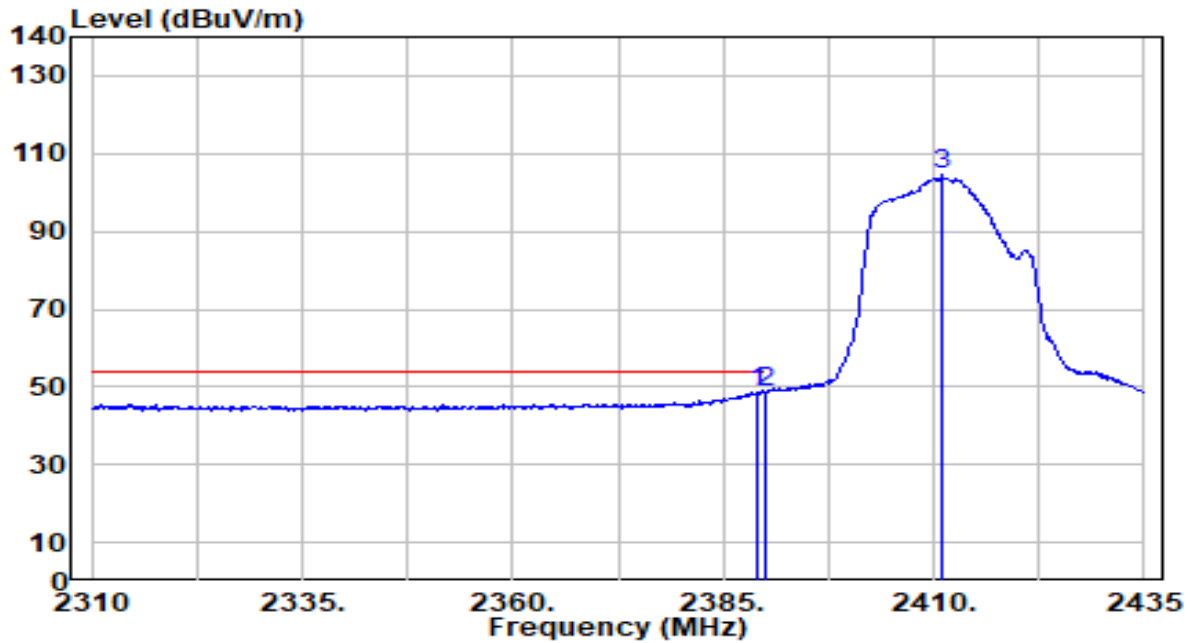

No	Frequency (MHz)	Reading (dBuV)	C.F (dB/m)	Measurement (dBuV/m)	Margin (dB)	Limit (dBuV/m)	Height (cm)	Angle (deg)	Remark (QP/PK/AV)
1	2389.000	18.21	30.44	48.65	-5.35	54.00	100	154	Average
2	* 2390.000	18.29	30.45	48.73	-5.27	54.00	100	154	Average
3	2411.000	73.91	30.49	104.40	N/A	N/A	100	154	Average

Note:

1. " \*", means this data is the worst emission level.
2. C.F (Correction Factor) = Antenna Factor (dB/m) + Cable Loss (dB).
3. Measurement (dBuV/m) = Reading(dBuV) + C.F (Correction Factor).
4. The emission levels of other frequencies are very lower than the limit and not show in test report.

EUT	BE11000 Ceiling Mount Wi-Fi 7 Access Point	Date of Test	2024-05-27
Factor	DRH18-E	Temp. / Humidity	20°C /65%
Polarity	Horizontal	Site / Test Engineer	AC2 / You
Test Mode	802.11be-20MHz_TX_CH 6 ANT 0+1	Test Voltage	AC 120V/60Hz

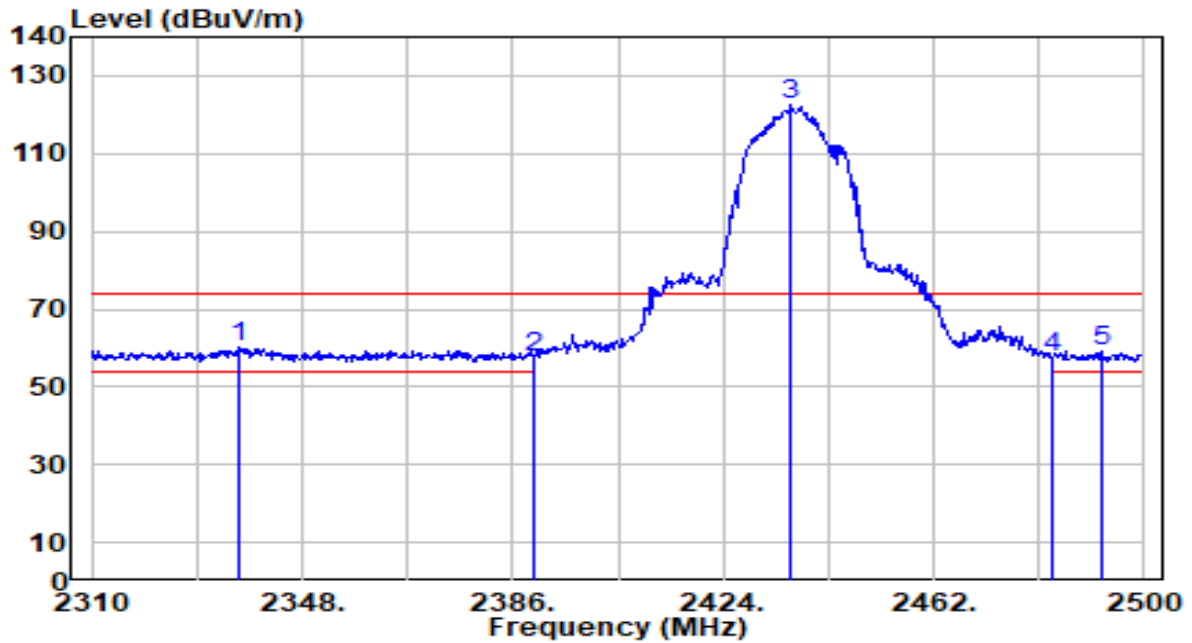

No	Frequency (MHz)	Reading (dBuV)	C.F (dB/m)	Measurement (dBuV/m)	Margin (dB)	Limit (dBuV/m)	Height (cm)	Angle (deg)	Remark (QP/PK/AV)
1	* 2336.600	29.93	30.30	60.22	-13.78	74.00	118	188	Peak
2	2390.000	27.37	30.45	57.82	-16.18	74.00	118	188	Peak
3	2436.350	91.80	30.52	122.32	N/A	N/A	118	188	Peak
4	2483.500	26.78	30.59	57.37	-16.63	74.00	118	188	Peak
5	2492.400	28.83	30.60	59.43	-14.57	74.00	118	188	Peak

Note:

- " \*", means this data is the worst emission level.
- C.F (Correction Factor) = Antenna Factor (dB/m) + Cable Loss (dB).
- Measurement (dBuV/m) = Reading(dBuV) + C.F (Correction Factor).
- The emission levels of other frequencies are very lower than the limit and not show in test report.

EUT	BE11000 Ceiling Mount Wi-Fi 7 Access Point	Date of Test	2024-05-27
Factor	DRH18-E	Temp. / Humidity	20°C /65%
Polarity	Horizontal	Site / Test Engineer	AC2 / You
Test Mode	802.11be-20MHz_TX_CH 6 ANT 0+1	Test Voltage	AC 120V/60Hz

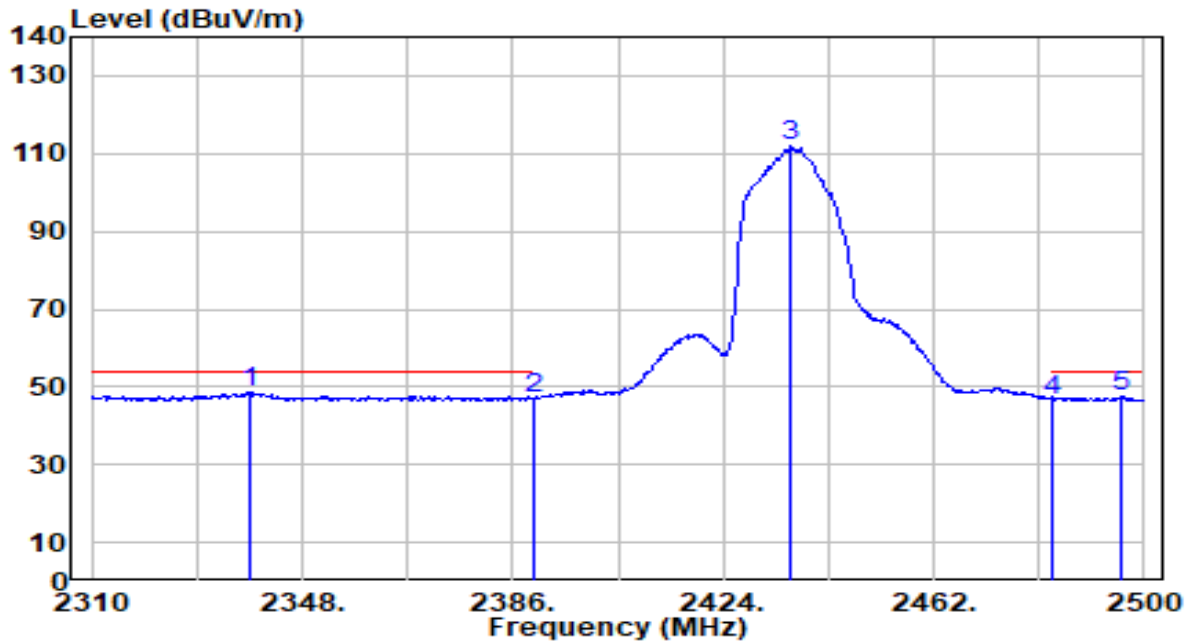

No	Frequency (MHz)	Reading (dBuV)	C.F (dB/m)	Measurement (dBuV/m)	Margin (dB)	Limit (dBuV/m)	Height (cm)	Angle (deg)	Remark (QP/PK/AV)
1	* 2338.690	18.22	30.30	48.52	-5.48	54.00	118	188	Average
2	2390.000	16.74	30.45	47.19	-6.81	54.00	118	188	Average
3	2436.160	81.21	30.52	111.74	N/A	N/A	118	188	Average
4	2483.500	16.14	30.59	46.73	-7.27	54.00	118	188	Average
5	2496.010	16.82	30.60	47.42	-6.58	54.00	118	188	Average

Note:

- " \*", means this data is the worst emission level.
- C.F (Correction Factor) = Antenna Factor (dB/m) + Cable Loss (dB).
- Measurement (dBuV/m) = Reading(dBuV) + C.F (Correction Factor).
- The emission levels of other frequencies are very lower than the limit and not show in test report.

EUT	BE11000 Ceiling Mount Wi-Fi 7 Access Point	Date of Test	2024-05-27
Factor	DRH18-E	Temp. / Humidity	20°C /65%
Polarity	Vertical	Site / Test Engineer	AC2 / You
Test Mode	802.11be-20MHz_TX_CH 6 ANT 0+1	Test Voltage	AC 120V/60Hz

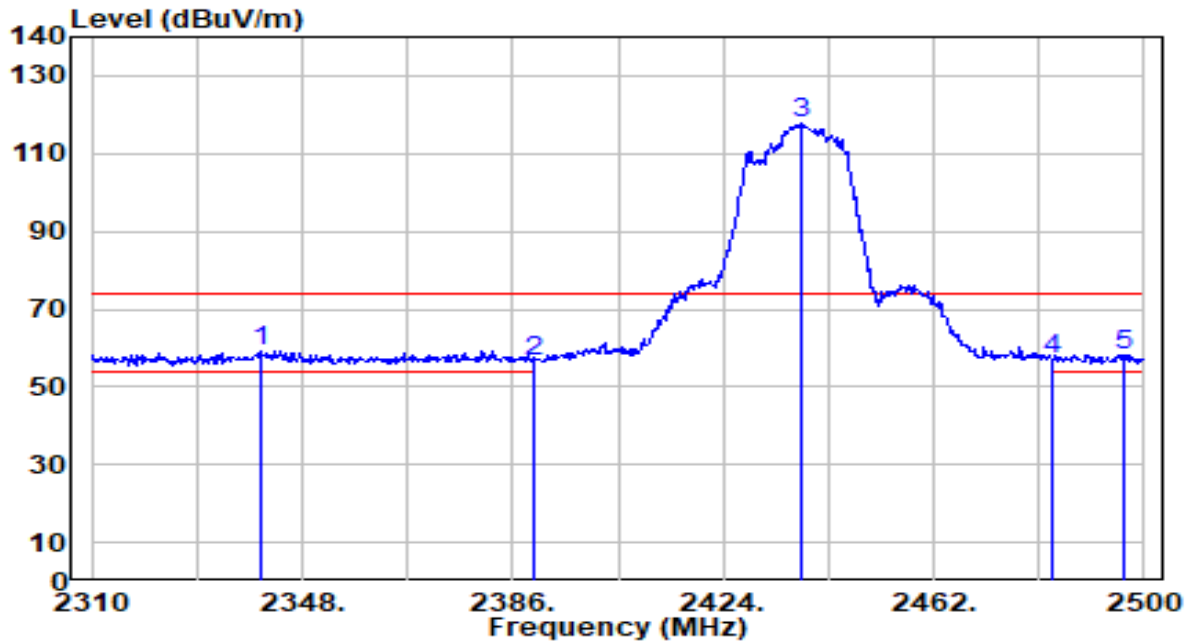

No	Frequency (MHz)	Reading (dBuV)	C.F (dB/m)	Measurement (dBuV/m)	Margin (dB)	Limit (dBuV/m)	Height (cm)	Angle (deg)	Remark (QP/PK/AV)
1	* 2340.400	28.74	30.31	59.05	-14.95	74.00	142	172	Peak
2	2390.000	26.04	30.45	56.49	-17.51	74.00	142	172	Peak
3	2438.060	87.51	30.53	118.04	N/A	N/A	142	172	Peak
4	2483.500	26.70	30.59	57.29	-16.71	74.00	142	172	Peak
5	2496.390	27.61	30.61	58.21	-15.79	74.00	142	172	Peak

Note:

1. " \*", means this data is the worst emission level.
2. C.F (Correction Factor) = Antenna Factor (dB/m) + Cable Loss (dB).
3. Measurement (dBuV/m) = Reading(dBuV) + C.F (Correction Factor).
4. The emission levels of other frequencies are very lower than the limit and not show in test report.

EUT	BE11000 Ceiling Mount Wi-Fi 7 Access Point	Date of Test	2024-05-27
Factor	DRH18-E	Temp. / Humidity	20°C /65%
Polarity	Vertical	Site / Test Engineer	AC2 / You
Test Mode	802.11be-20MHz_TX_CH 6 ANT 0+1	Test Voltage	AC 120V/60Hz

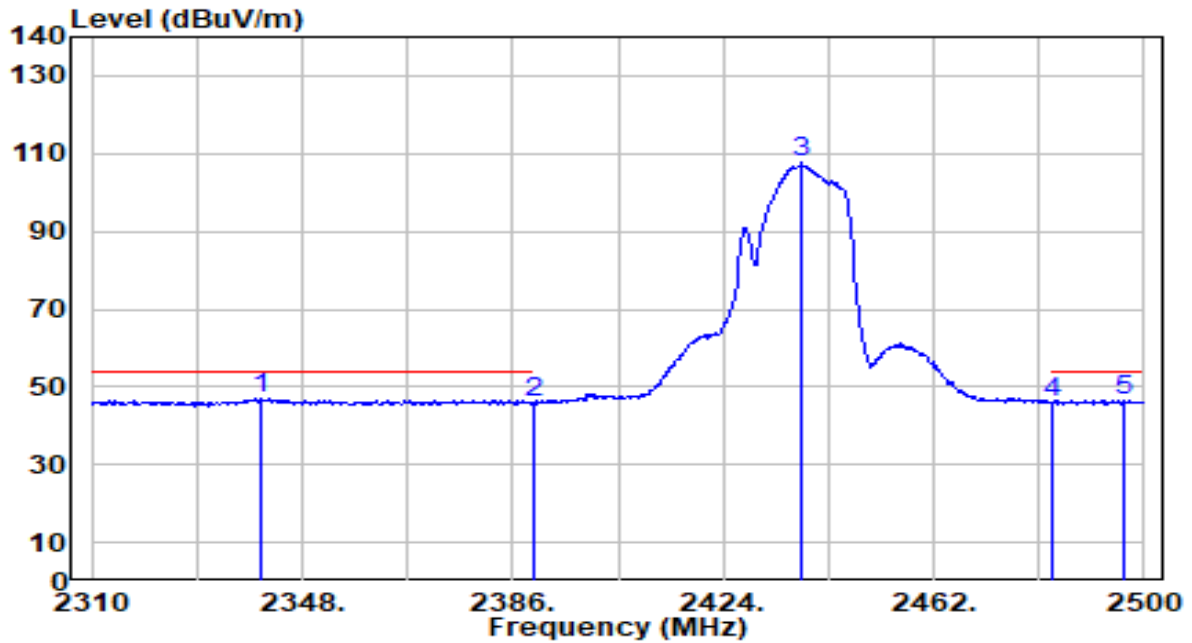

No	Frequency (MHz)	Reading (dBuV)	C.F (dB/m)	Measurement (dBuV/m)	Margin (dB)	Limit (dBuV/m)	Height (cm)	Angle (deg)	Remark (QP/PK/AV)
1	* 2340.590	16.53	30.31	46.84	-7.16	54.00	142	172	Average
2	2390.000	15.55	30.45	45.99	-8.01	54.00	142	172	Average
3	2438.060	77.01	30.53	107.54	N/A	N/A	142	172	Average
4	2483.500	15.32	30.59	45.90	-8.10	54.00	142	172	Average
5	2496.390	15.87	30.61	46.47	-7.53	54.00	142	172	Average

Note:

- " \*", means this data is the worst emission level.
- C.F (Correction Factor) = Antenna Factor (dB/m) + Cable Loss (dB).
- Measurement (dBuV/m) = Reading(dBuV) + C.F (Correction Factor).
- The emission levels of other frequencies are very lower than the limit and not show in test report.



EUT	BE11000 Ceiling Mount Wi-Fi 7 Access Point	Date of Test	2024-05-27
Factor	DRH18-E	Temp. / Humidity	20°C /65%
Polarity	Horizontal	Site / Test Engineer	AC2 / You
Test Mode	802.11be-20MHz_TX_CH 11 ANT 0+1	Test Voltage	AC 120V/60Hz

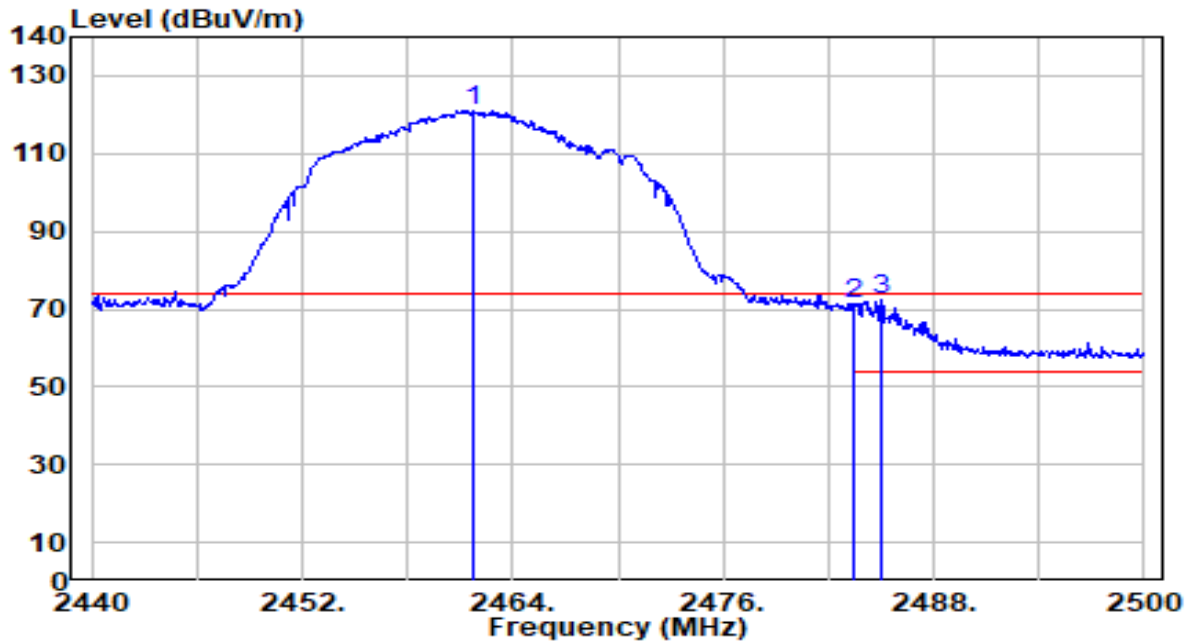

No	Frequency (MHz)	Reading (dBUV)	C.F (dB/m)	Measurement (dBUV/m)	Margin (dB)	Limit (dBUV/m)	Height (cm)	Angle (deg)	Remark (QP/PK/AV)
1	2461.780	90.58	30.56	121.14	N/A	N/A	118	188	Peak
2	2483.500	40.81	30.59	71.39	-2.61	74.00	118	188	Peak
3	* 2484.940	41.73	30.59	72.32	-1.68	74.00	118	188	Peak

Note:

1. "\*" , means this data is the worst emission level.
2. C.F (Correction Factor) = Antenna Factor (dB/m) + Cable Loss (dB).
3. Measurement (dBUV/m) = Reading(dBUV) + C.F (Correction Factor).
4. The emission levels of other frequencies are very lower than the limit and not show in test report.

EUT	BE11000 Ceiling Mount Wi-Fi 7 Access Point	Date of Test	2024-05-27
Factor	DRH18-E	Temp. / Humidity	20°C /65%
Polarity	Horizontal	Site / Test Engineer	AC2 / You
Test Mode	802.11be-20MHz_TX_CH 11 ANT 0+1	Test Voltage	AC 120V/60Hz

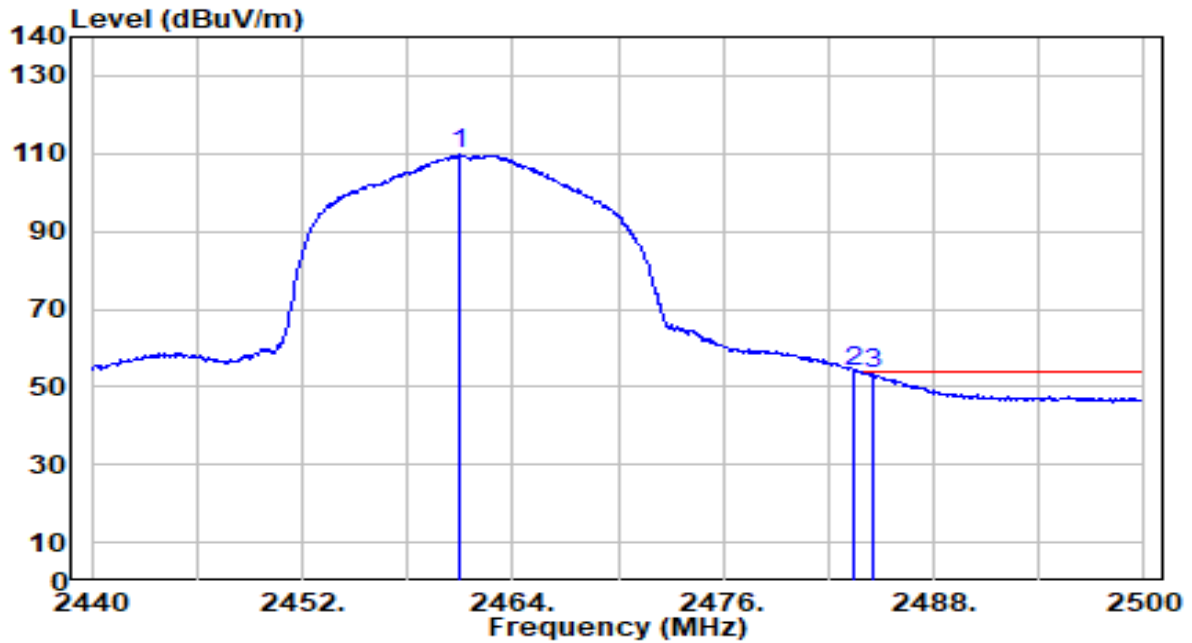

No	Frequency (MHz)	Reading (dBUV)	C.F (dB/m)	Measurement (dBUV/m)	Margin (dB)	Limit (dBUV/m)	Height (cm)	Angle (deg)	Remark (QP/PK/AV)
1	2461.000	79.40	30.56	109.96	N/A	N/A	118	188	Average
2	* 2483.500	23.22	30.59	53.81	-0.19	54.00	118	188	Average
3	2484.520	22.60	30.59	53.19	-0.81	54.00	118	188	Average

Note:

1. " \*", means this data is the worst emission level.
2. C.F (Correction Factor) = Antenna Factor (dB/m) + Cable Loss (dB).
3. Measurement (dBUV/m) = Reading(dBUV) + C.F (Correction Factor).
4. The emission levels of other frequencies are very lower than the limit and not show in test report.

EUT	BE11000 Ceiling Mount Wi-Fi 7 Access Point	Date of Test	2024-05-27
Factor	DRH18-E	Temp. / Humidity	20°C /65%
Polarity	Vertical	Site / Test Engineer	AC2 / You
Test Mode	802.11be-20MHz_TX_CH 11 ANT 0+1	Test Voltage	AC 120V/60Hz

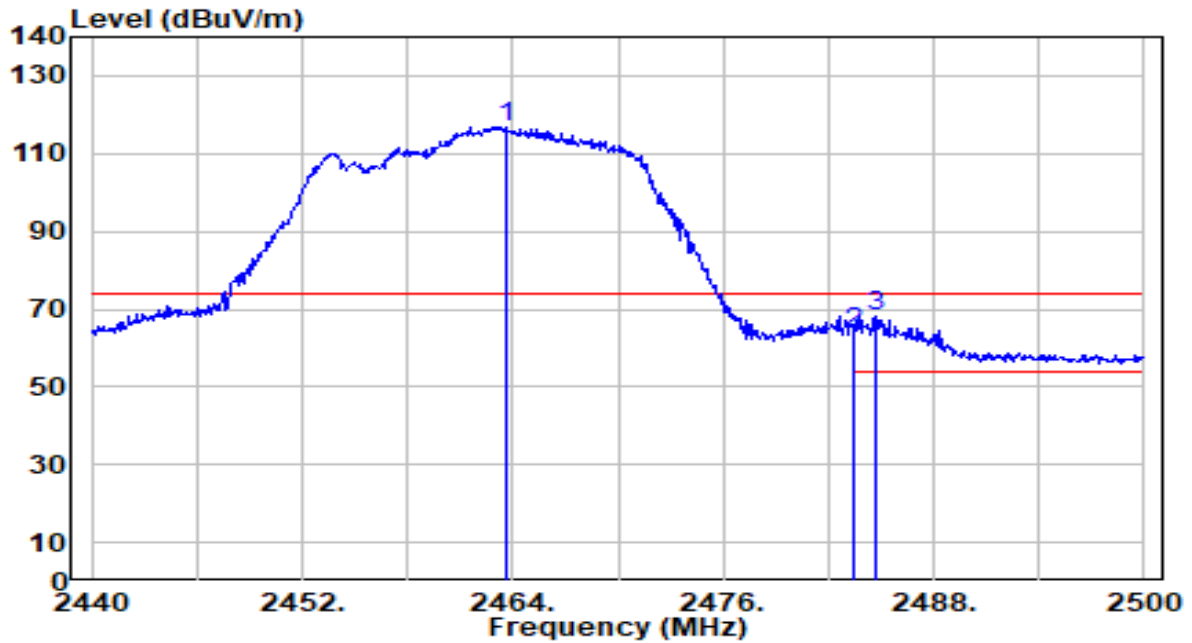

No	Frequency (MHz)	Reading (dBuV)	C.F (dB/m)	Measurement (dBuV/m)	Margin (dB)	Limit (dBuV/m)	Height (cm)	Angle (deg)	Remark (QP/PK/AV)
1	2463.580	86.37	30.56	116.93	N/A	N/A	142	172	Peak
2	2483.500	33.44	30.59	64.02	-9.98	74.00	142	172	Peak
3	* 2484.640	37.51	30.59	68.10	-5.90	74.00	142	172	Peak

Note:

1. " \*", means this data is the worst emission level.
2. C.F (Correction Factor) = Antenna Factor (dB/m) + Cable Loss (dB).
3. Measurement (dBuV/m) = Reading(dBuV) + C.F (Correction Factor).
4. The emission levels of other frequencies are very lower than the limit and not show in test report.

EUT	BE11000 Ceiling Mount Wi-Fi 7 Access Point	Date of Test	2024-05-27
Factor	DRH18-E	Temp. / Humidity	20°C /65%
Polarity	Vertical	Site / Test Engineer	AC2 / You
Test Mode	802.11be-20MHz_TX_CH 11 ANT 0+1	Test Voltage	AC 120V/60Hz

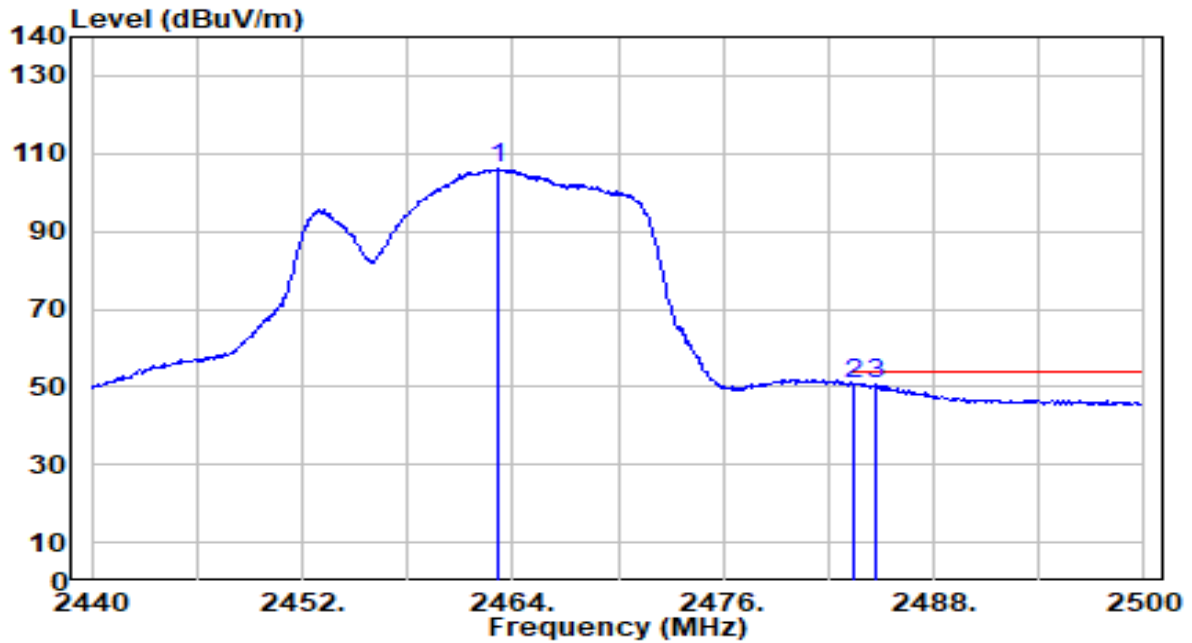

No	Frequency (MHz)	Reading (dBUV)	C.F (dB/m)	Measurement (dBUV/m)	Margin (dB)	Limit (dBUV/m)	Height (cm)	Angle (deg)	Remark (QP/PK/AV)
1	2463.220	75.51	30.56	106.07	N/A	N/A	142	172	Average
2	* 2483.500	20.00	30.59	50.59	-3.41	54.00	142	172	Average
3	2484.640	19.88	30.59	50.47	-3.53	54.00	142	172	Average

Note:

1. " \*", means this data is the worst emission level.
2. C.F (Correction Factor) = Antenna Factor (dB/m) + Cable Loss (dB).
3. Measurement (dBUV/m) = Reading(dBUV) + C.F (Correction Factor).
4. The emission levels of other frequencies are very lower than the limit and not show in test report.

EUT	BE11000 Ceiling Mount Wi-Fi 7 Access Point	Date of Test	2024-05-27
Factor	DRH18-E	Temp. / Humidity	20°C /65%
Polarity	Horizontal	Site / Test Engineer	AC2 / You
Test Mode	802.11be-40MHz_TX_CH 3 ANT 0+1	Test Voltage	AC 120V/60Hz

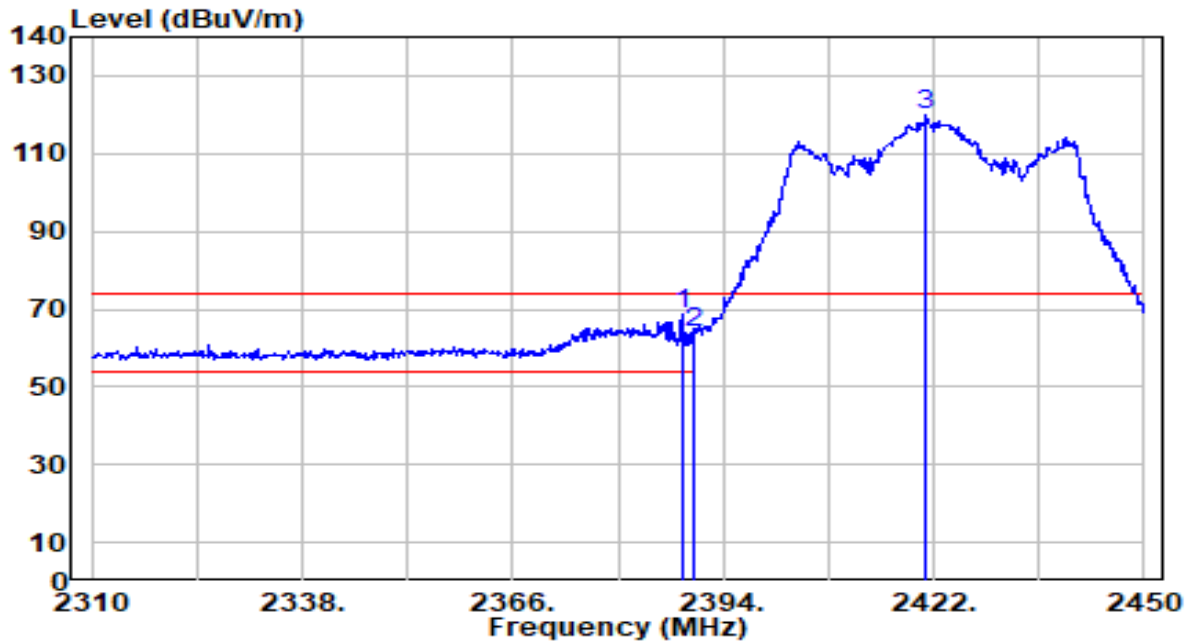

No	Frequency (MHz)	Reading (dBuV)	C.F (dB/m)	Measurement (dBuV/m)	Margin (dB)	Limit (dBuV/m)	Height (cm)	Angle (deg)	Remark (QP/PK/AV)	
1	*	2388.540	38.44	30.44	68.88	-5.12	74.00	126	186	Peak
2		2390.000	33.33	30.45	63.78	-10.22	74.00	126	186	Peak
3		2420.880	89.17	30.50	119.68	N/A	N/A	126	186	Peak

Note:

1. " \*", means this data is the worst emission level.
2. C.F (Correction Factor) = Antenna Factor (dB/m) + Cable Loss (dB).
3. Measurement (dBuV/m) = Reading(dBuV) + C.F (Correction Factor).
4. The emission levels of other frequencies are very lower than the limit and not show in test report.

EUT	BE11000 Ceiling Mount Wi-Fi 7 Access Point	Date of Test	2024-05-27
Factor	DRH18-E	Temp. / Humidity	20°C /65%
Polarity	Horizontal	Site / Test Engineer	AC2 / You
Test Mode	802.11be-40MHz_TX_CH 3 ANT 0+1	Test Voltage	AC 120V/60Hz

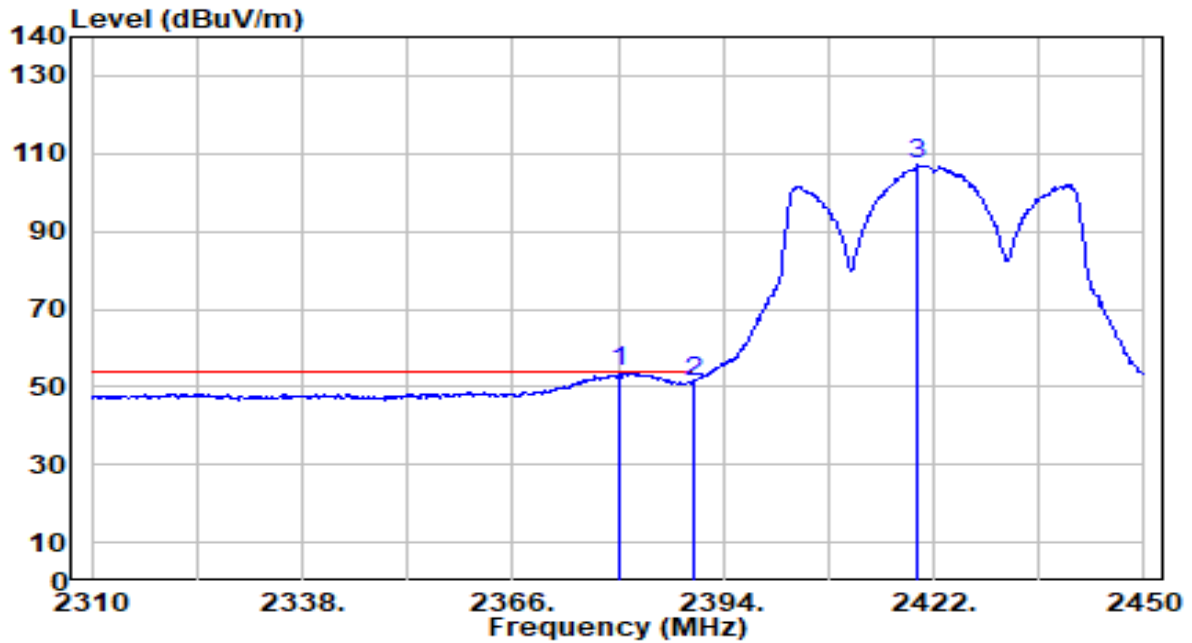

No	Frequency (MHz)	Reading (dBuV)	C.F (dB/m)	Measurement (dBuV/m)	Margin (dB)	Limit (dBuV/m)	Height (cm)	Angle (deg)	Remark (QP/PK/AV)
1	*	23.30	30.42	53.72	-0.28	54.00	126	186	Average
2		20.78	30.45	51.22	-2.78	54.00	126	186	Average
3		76.53	30.50	107.04	N/A	N/A	126	186	Average

Note:

1. "\*" , means this data is the worst emission level.
2. C.F (Correction Factor) = Antenna Factor (dB/m) + Cable Loss (dB).
3. Measurement (dBuV/m) = Reading(dBuV) + C.F (Correction Factor).
4. The emission levels of other frequencies are very lower than the limit and not show in test report.

EUT	BE11000 Ceiling Mount Wi-Fi 7 Access Point	Date of Test	2024-05-27
Factor	DRH18-E	Temp. / Humidity	20°C /65%
Polarity	Vertical	Site / Test Engineer	AC2 / You
Test Mode	802.11be-40MHz_TX_CH 3 ANT 0+1	Test Voltage	AC 120V/60Hz

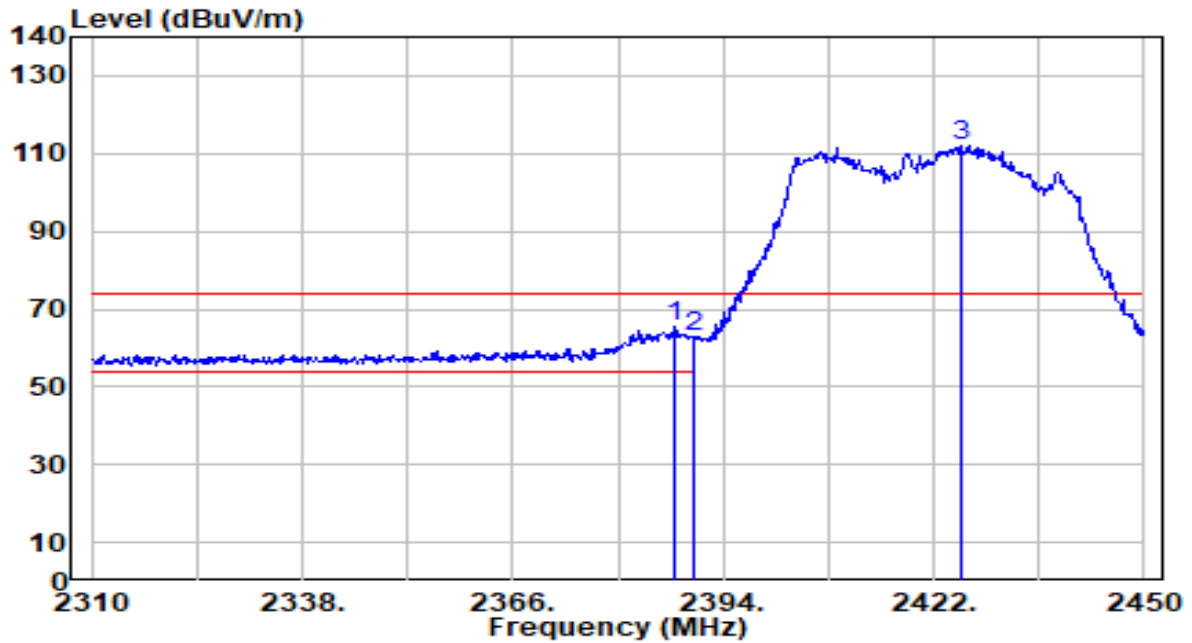

No	Frequency (MHz)	Reading (dBuV)	C.F (dB/m)	Measurement (dBuV/m)	Margin (dB)	Limit (dBuV/m)	Height (cm)	Angle (deg)	Remark (QP/PK/AV)	
1	*	2387.560	34.88	30.44	65.32	-8.68	74.00	100	47	Peak
2		2390.000	32.47	30.45	62.92	-11.08	74.00	100	47	Peak
3		2425.640	81.28	30.51	111.79	N/A	N/A	100	47	Peak

Note:

1. " \*", means this data is the worst emission level.
2. C.F (Correction Factor) = Antenna Factor (dB/m) + Cable Loss (dB).
3. Measurement (dBuV/m) = Reading(dBuV) + C.F (Correction Factor).
4. The emission levels of other frequencies are very lower than the limit and not show in test report.

EUT	BE11000 Ceiling Mount Wi-Fi 7 Access Point	Date of Test	2024-05-27
Factor	DRH18-E	Temp. / Humidity	20°C /65%
Polarity	Vertical	Site / Test Engineer	AC2 / You
Test Mode	802.11be-40MHz_TX_CH 3 ANT 0+1	Test Voltage	AC 120V/60Hz

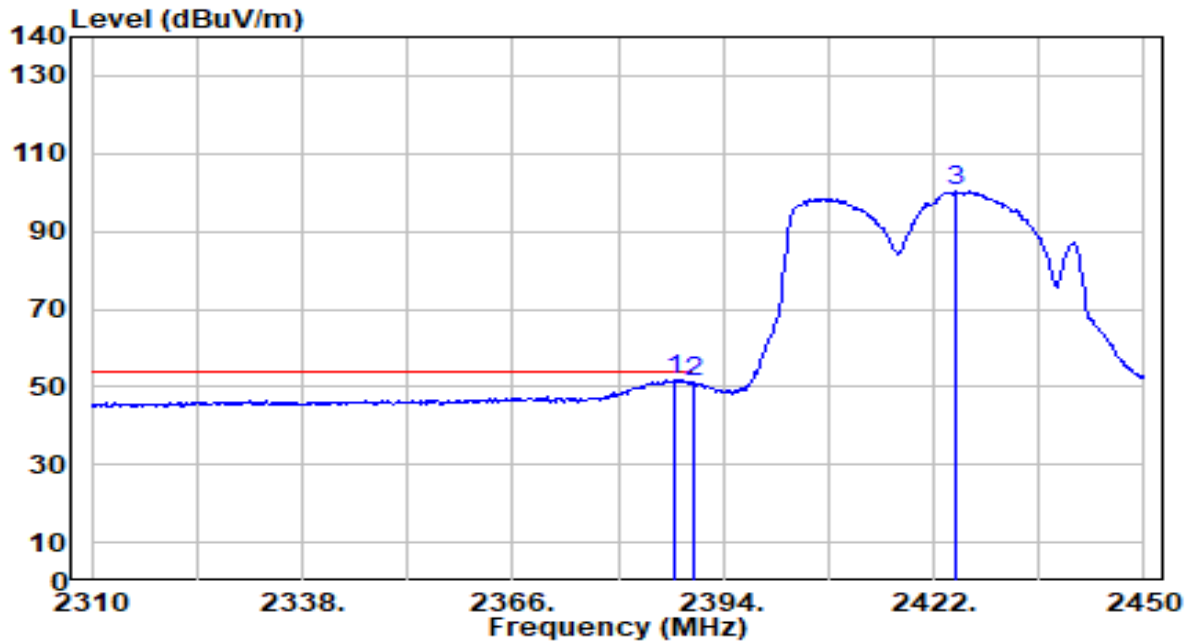

No	Frequency (MHz)	Reading (dBuV)	C.F (dB/m)	Measurement (dBuV/m)	Margin (dB)	Limit (dBuV/m)	Height (cm)	Angle (deg)	Remark (QP/PK/AV)	
1	*	2387.560	21.49	30.44	51.93	-2.07	54.00	100	47	Average
2		2390.000	20.66	30.45	51.11	-2.89	54.00	100	47	Average
3		2425.080	69.88	30.51	100.39	N/A	N/A	100	47	Average

Note:

1. " \*", means this data is the worst emission level.
2. C.F (Correction Factor) = Antenna Factor (dB/m) + Cable Loss (dB).
3. Measurement (dBuV/m) = Reading(dBuV) + C.F (Correction Factor).
4. The emission levels of other frequencies are very lower than the limit and not show in test report.



EUT	BE11000 Ceiling Mount Wi-Fi 7 Access Point	Date of Test	2024-05-27
Factor	DRH18-E	Temp. / Humidity	20°C /65%
Polarity	Horizontal	Site / Test Engineer	AC2 / You
Test Mode	802.11be-40MHz_TX_CH 6 ANT 0+1	Test Voltage	AC 120V/60Hz

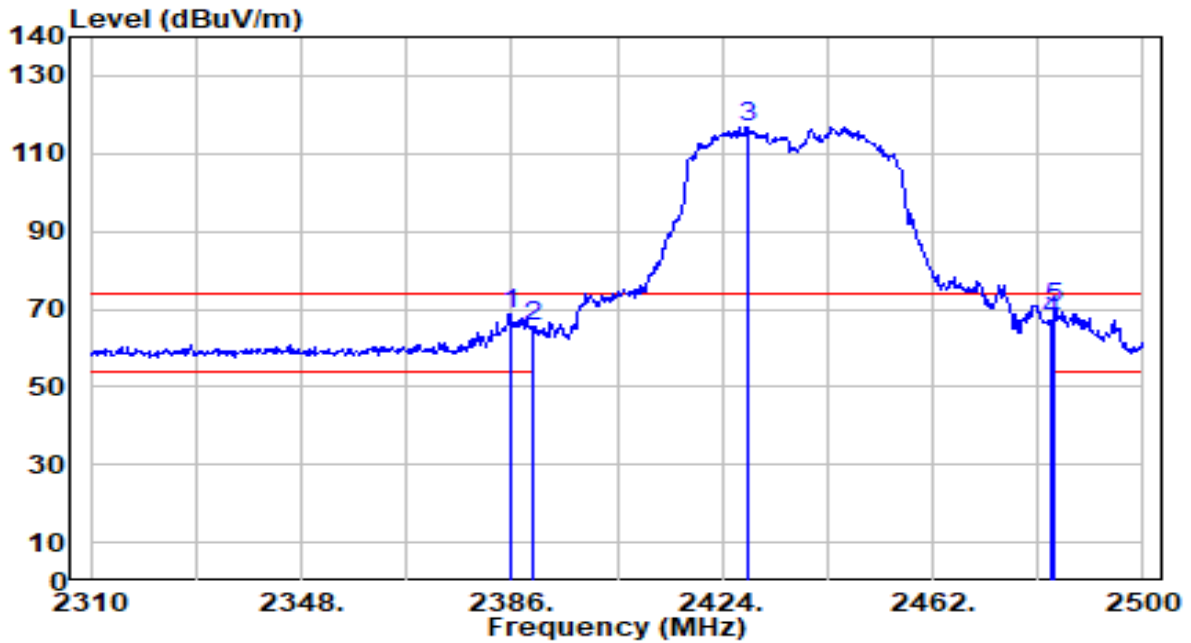

No	Frequency (MHz)	Reading (dBuV)	C.F (dB/m)	Measurement (dBuV/m)	Margin (dB)	Limit (dBuV/m)	Height (cm)	Angle (deg)	Remark (QP/PK/AV)
1	2385.620	38.47	30.44	68.90	-5.10	74.00	126	186	Peak
2	2390.000	35.03	30.45	65.48	-8.52	74.00	126	186	Peak
3	2428.560	86.44	30.51	116.95	N/A	N/A	126	186	Peak
4	2483.500	36.51	30.59	67.10	-6.90	74.00	126	186	Peak
5	* 2484.040	39.65	30.59	70.24	-3.76	74.00	126	186	Peak

Note:

1. " \*", means this data is the worst emission level.
2. C.F (Correction Factor) = Antenna Factor (dB/m) + Cable Loss (dB).
3. Measurement (dBuV/m) = Reading(dBuV) + C.F (Correction Factor).
4. The emission levels of other frequencies are very lower than the limit and not show in test report.

EUT	BE11000 Ceiling Mount Wi-Fi 7 Access Point	Date of Test	2024-05-27
Factor	DRH18-E	Temp. / Humidity	20°C /65%
Polarity	Horizontal	Site / Test Engineer	AC2 / You
Test Mode	802.11be-40MHz_TX_CH 6 ANT 0+1	Test Voltage	AC 120V/60Hz

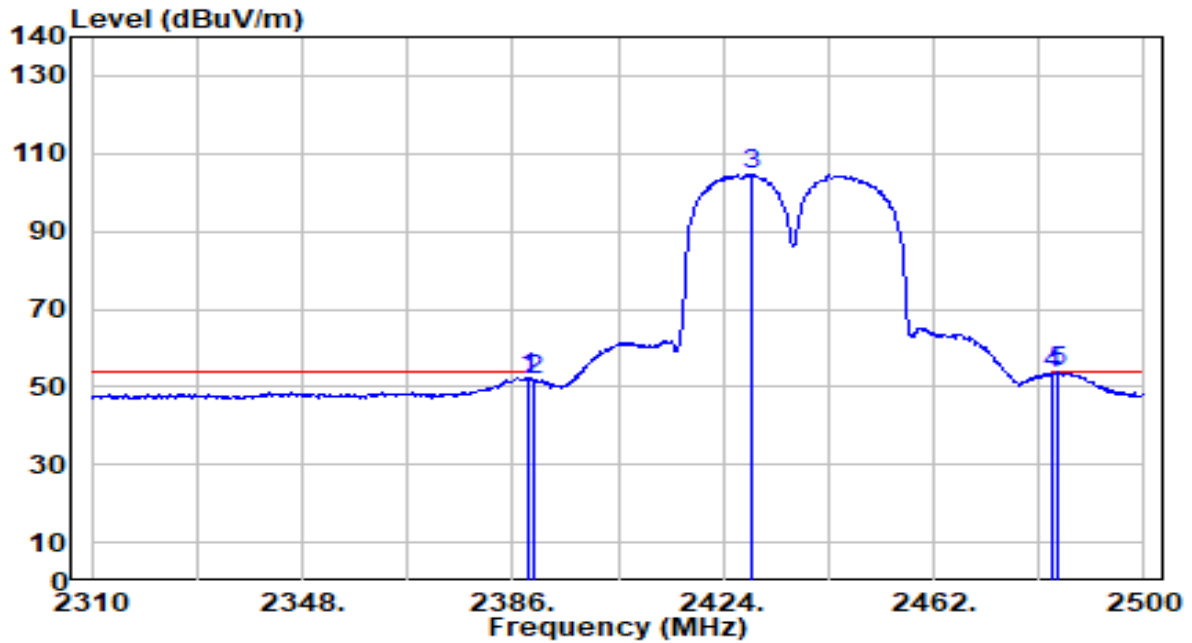

No	Frequency (MHz)	Reading (dBuV)	C.F (dB/m)	Measurement (dBuV/m)	Margin (dB)	Limit (dBuV/m)	Height (cm)	Angle (deg)	Remark (QP/PK/AV)
1	2389.040	22.01	30.44	52.45	-1.55	54.00	126	186	Average
2	2390.000	21.23	30.45	51.68	-2.32	54.00	126	186	Average
3	2429.130	74.26	30.52	104.77	N/A	N/A	126	186	Average
4	2483.500	22.52	30.59	53.11	-0.89	54.00	126	186	Average
5	* 2484.230	23.30	30.59	53.89	-0.11	54.00	126	186	Average

Note:

- "\*" means this data is the worst emission level.
- C.F (Correction Factor) = Antenna Factor (dB/m) + Cable Loss (dB).
- Measurement (dBuV/m) = Reading(dBuV) + C.F (Correction Factor).
- The emission levels of other frequencies are very lower than the limit and not show in test report.

EUT	BE11000 Ceiling Mount Wi-Fi 7 Access Point	Date of Test	2024-05-27
Factor	DRH18-E	Temp. / Humidity	20°C /65%
Polarity	Vertical	Site / Test Engineer	AC2 / You
Test Mode	802.11be-40MHz_TX_CH 6 ANT 0+1	Test Voltage	AC 120V/60Hz

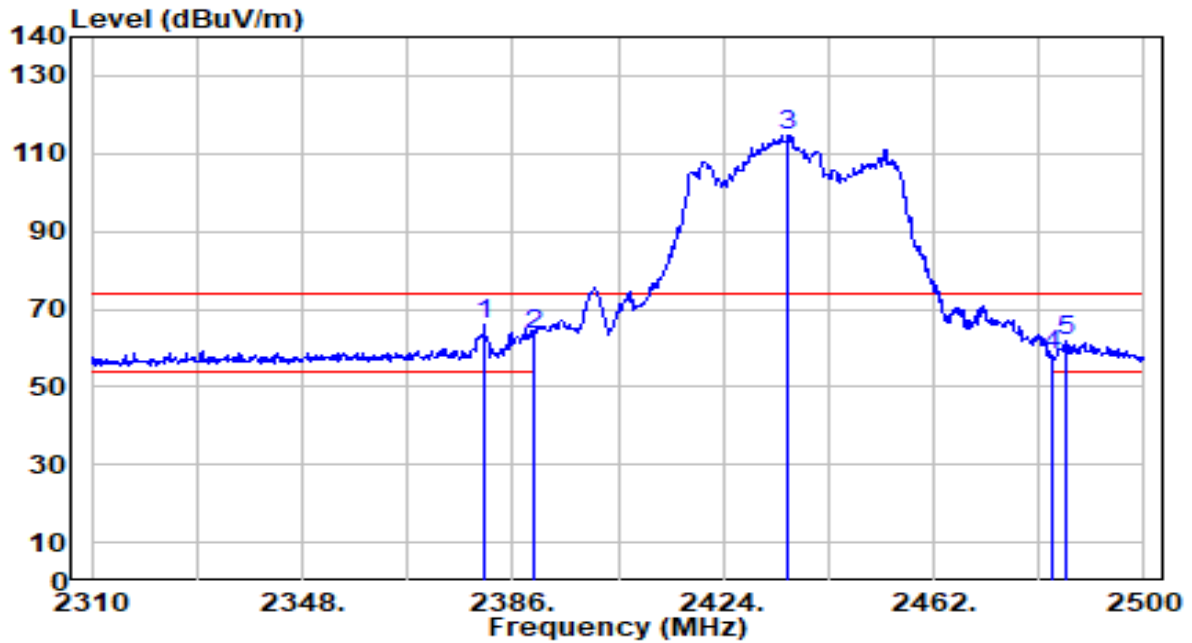

No	Frequency (MHz)	Reading (dBuV)	C.F (dB/m)	Measurement (dBuV/m)	Margin (dB)	Limit (dBuV/m)	Height (cm)	Angle (deg)	Remark (QP/PK/AV)
1	* 2380.870	35.43	30.42	65.85	-8.15	74.00	100	47	Peak
2	2390.000	32.77	30.45	63.22	-10.78	74.00	100	47	Peak
3	2435.590	84.22	30.52	114.75	N/A	N/A	100	47	Peak
4	2483.500	27.64	30.59	58.23	-15.77	74.00	100	47	Peak
5	2485.750	30.99	30.59	61.58	-12.42	74.00	100	47	Peak

Note:

1. " \*", means this data is the worst emission level.
2. C.F (Correction Factor) = Antenna Factor (dB/m) + Cable Loss (dB).
3. Measurement (dBuV/m) = Reading(dBuV) + C.F (Correction Factor).
4. The emission levels of other frequencies are very lower than the limit and not show in test report.

EUT	BE11000 Ceiling Mount Wi-Fi 7 Access Point	Date of Test	2024-05-27
Factor	DRH18-E	Temp. / Humidity	20°C /65%
Polarity	Vertical	Site / Test Engineer	AC2 / You
Test Mode	802.11be-40MHz_TX_CH 6 ANT 0+1	Test Voltage	AC 120V/60Hz

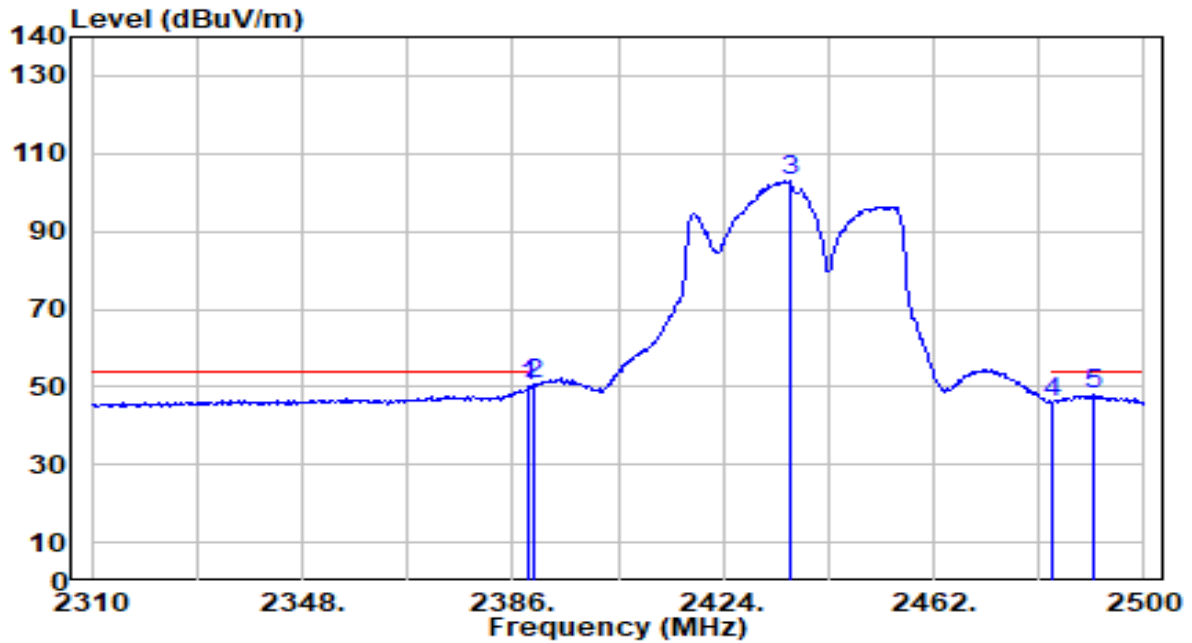

No	Frequency (MHz)	Reading (dBuV)	C.F (dB/m)	Measurement (dBuV/m)	Margin (dB)	Limit (dBuV/m)	Height (cm)	Angle (deg)	Remark (QP/PK/AV)
1	2389.040	19.50	30.44	49.94	-4.06	54.00	100	47	Average
2	* 2390.000	20.02	30.45	50.46	-3.54	54.00	100	47	Average
3	2436.160	72.51	30.52	103.04	N/A	N/A	100	47	Average
4	2483.500	15.56	30.59	46.14	-7.86	54.00	100	47	Average
5	2490.690	17.23	30.60	47.82	-6.18	54.00	100	47	Average

Note:

- "\*" means this data is the worst emission level.
- C.F (Correction Factor) = Antenna Factor (dB/m) + Cable Loss (dB).
- Measurement (dBuV/m) = Reading(dBuV) + C.F (Correction Factor).
- The emission levels of other frequencies are very lower than the limit and not show in test report.

EUT	BE11000 Ceiling Mount Wi-Fi 7 Access Point	Date of Test	2024-05-27
Factor	DRH18-E	Temp. / Humidity	20°C /65%
Polarity	Horizontal	Site / Test Engineer	AC2 / You
Test Mode	802.11be-40MHz_TX_CH 9 ANT 0+1	Test Voltage	AC 120V/60Hz

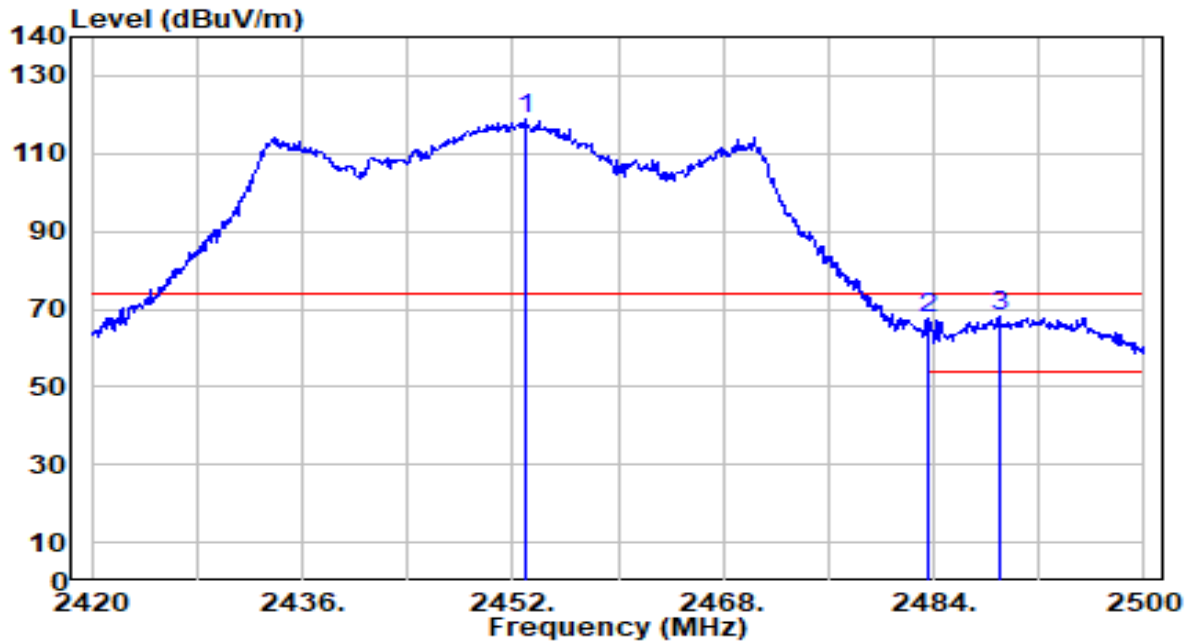

No	Frequency (MHz)	Reading (dBuV)	C.F (dB/m)	Measurement (dBuV/m)	Margin (dB)	Limit (dBuV/m)	Height (cm)	Angle (deg)	Remark (QP/PK/AV)
1	2452.960	88.23	30.55	118.78	N/A	N/A	126	186	Peak
2	2483.500	36.90	30.59	67.48	-6.52	74.00	126	186	Peak
3	* 2488.960	37.58	30.60	68.18	-5.82	74.00	126	186	Peak

Note:

1. " \*", means this data is the worst emission level.
2. C.F (Correction Factor) = Antenna Factor (dB/m) + Cable Loss (dB).
3. Measurement (dBuV/m) = Reading(dBuV) + C.F (Correction Factor).
4. The emission levels of other frequencies are very lower than the limit and not show in test report.

EUT	BE11000 Ceiling Mount Wi-Fi 7 Access Point	Date of Test	2024-05-27
Factor	DRH18-E	Temp. / Humidity	20°C /65%
Polarity	Horizontal	Site / Test Engineer	AC2 / You
Test Mode	802.11be-40MHz_TX_CH 9 ANT 0+1	Test Voltage	AC 120V/60Hz

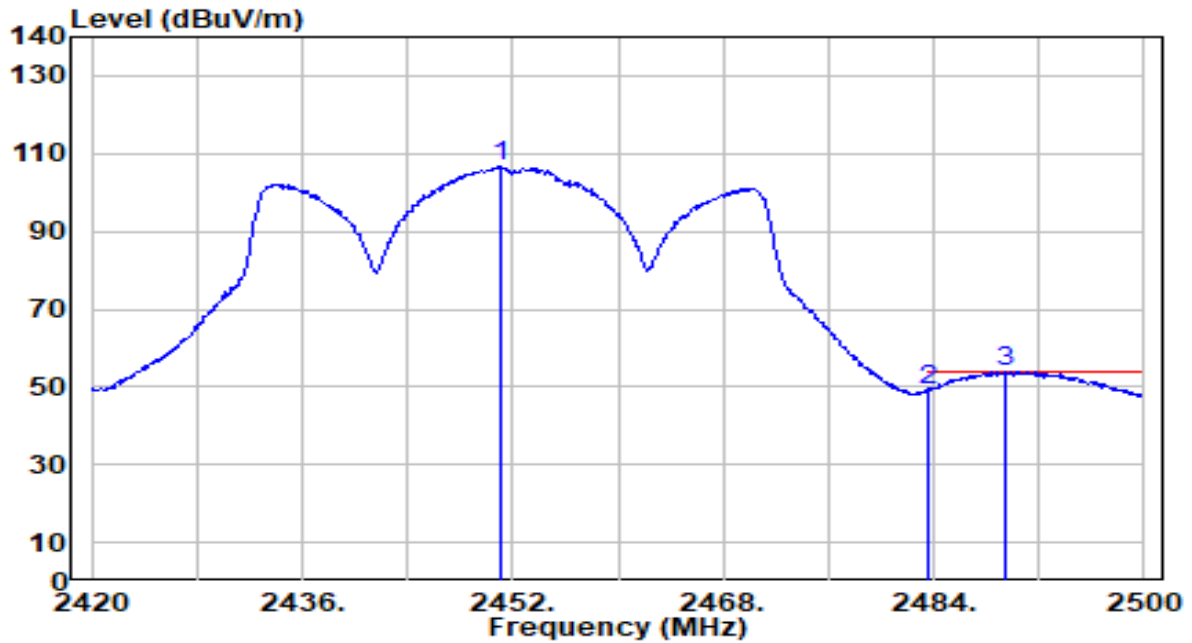

No	Frequency (MHz)	Reading (dBuV)	C.F (dB/m)	Measurement (dBuV/m)	Margin (dB)	Limit (dBuV/m)	Height (cm)	Angle (deg)	Remark (QP/PK/AV)
1	2451.120	76.25	30.54	106.79	N/A	N/A	126	186	Average
2	2483.500	18.55	30.59	49.14	-4.86	54.00	126	186	Average
3	* 2489.520	23.21	30.60	53.81	-0.19	54.00	126	186	Average

Note:

1. " \*", means this data is the worst emission level.
2. C.F (Correction Factor) = Antenna Factor (dB/m) + Cable Loss (dB).
3. Measurement (dBuV/m) = Reading(dBuV) + C.F (Correction Factor).
4. The emission levels of other frequencies are very lower than the limit and not show in test report.

EUT	BE11000 Ceiling Mount Wi-Fi 7 Access Point	Date of Test	2024-05-27
Factor	DRH18-E	Temp. / Humidity	20°C /65%
Polarity	Vertical	Site / Test Engineer	AC2 / You
Test Mode	802.11be-40MHz_TX_CH 9 ANT 0+1	Test Voltage	AC 120V/60Hz

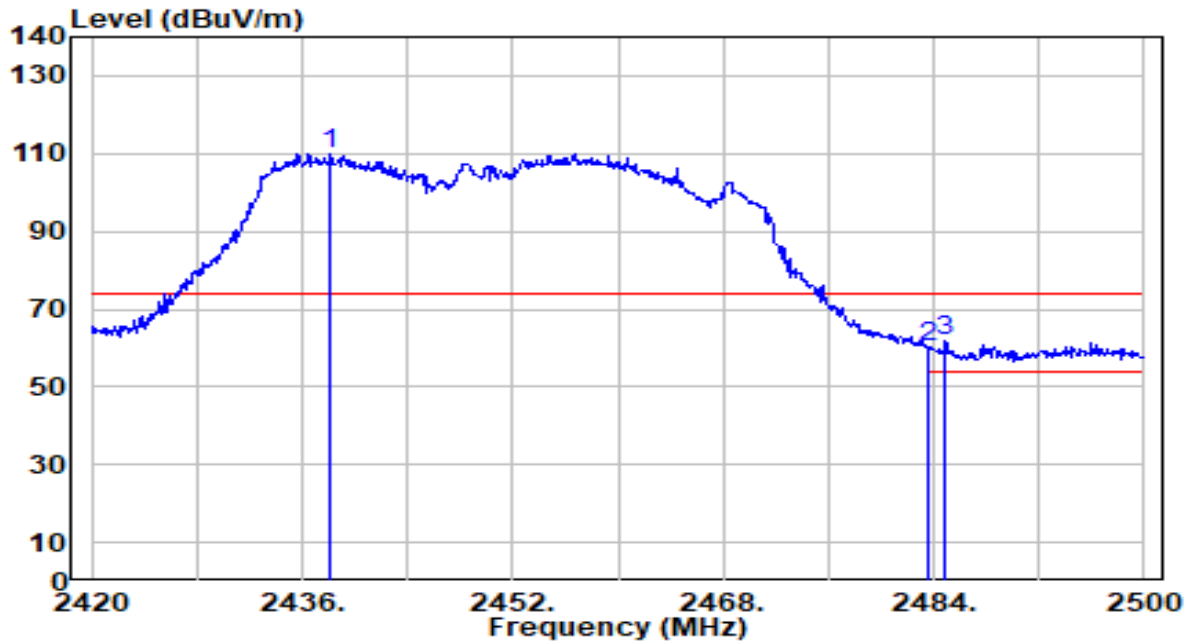

No	Frequency (MHz)	Reading (dBuV)	C.F (dB/m)	Measurement (dBuV/m)	Margin (dB)	Limit (dBuV/m)	Height (cm)	Angle (deg)	Remark (QP/PK/AV)
1	2438.160	79.41	30.53	109.93	N/A	N/A	100	47	Peak
2	2483.500	29.82	30.59	60.41	-13.59	74.00	100	47	Peak
3	* 2484.880	31.03	30.59	61.62	-12.38	74.00	100	47	Peak

Note:

1. " \*", means this data is the worst emission level.
2. C.F (Correction Factor) = Antenna Factor (dB/m) + Cable Loss (dB).
3. Measurement (dBuV/m) = Reading(dBuV) + C.F (Correction Factor).
4. The emission levels of other frequencies are very lower than the limit and not show in test report.

EUT	BE11000 Ceiling Mount Wi-Fi 7 Access Point	Date of Test	2024-05-27
Factor	DRH18-E	Temp. / Humidity	20°C /65%
Polarity	Vertical	Site / Test Engineer	AC2 / You
Test Mode	802.11be-40MHz_TX_CH 9 ANT 0+1	Test Voltage	AC 120V/60Hz

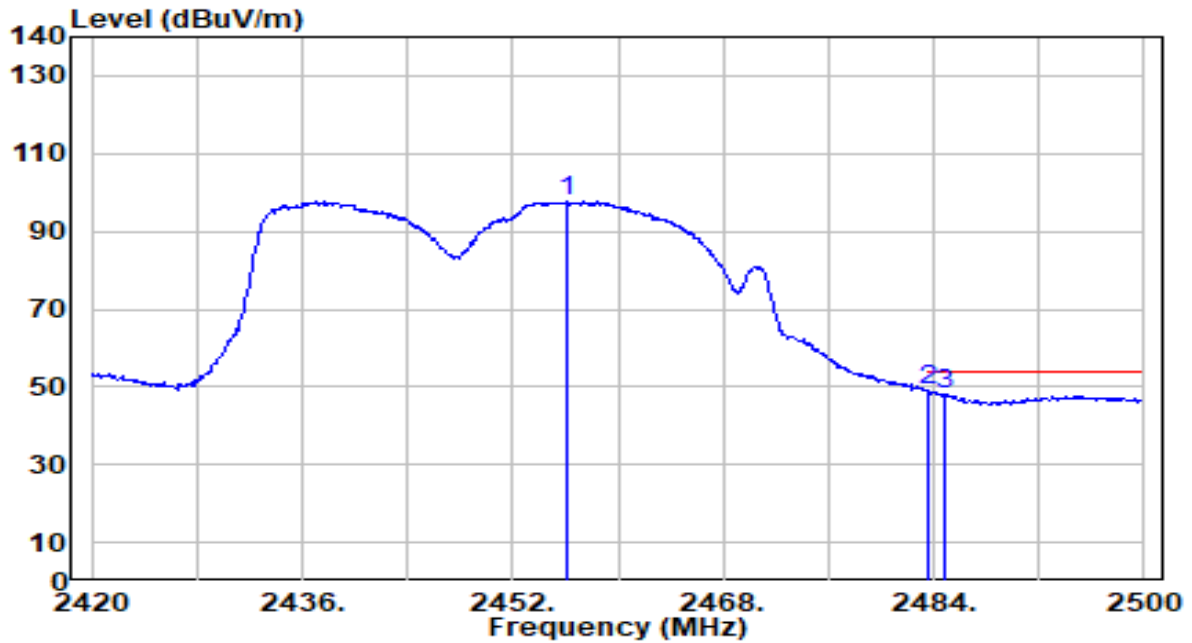

No	Frequency (MHz)	Reading (dBuV)	C.F (dB/m)	Measurement (dBuV/m)	Margin (dB)	Limit (dBuV/m)	Height (cm)	Angle (deg)	Remark (QP/PK/AV)
1	2456.080	67.21	30.55	97.76	N/A	N/A	100	47	Average
2	* 2483.500	18.49	30.59	49.07	-4.93	54.00	100	47	Average
3	2484.800	17.49	30.59	48.08	-5.92	54.00	100	47	Average

Note:

1. " \*", means this data is the worst emission level.
2. C.F (Correction Factor) = Antenna Factor (dB/m) + Cable Loss (dB).
3. Measurement (dBuV/m) = Reading(dBuV) + C.F (Correction Factor).
4. The emission levels of other frequencies are very lower than the limit and not show in test report.



## 7.8. AC Conducted Emissions Measurement

### 7.8.1. Test Limit

FCC Part 15 Subpart C Paragraph 15.207 Limits		
Frequency (MHz)	QP (dBuV)	AV (dBuV)
0.15 - 0.50	66 - 56	56 - 46
0.50 - 5.0	56	46
5.0 - 30	60	50

Note 1: The lower limit shall apply at the transition frequencies.

Note 2: The limit decreases linearly with the logarithm of the frequency in the range 0.15MHz to 0.5MHz.

### 7.8.2. Test Setup

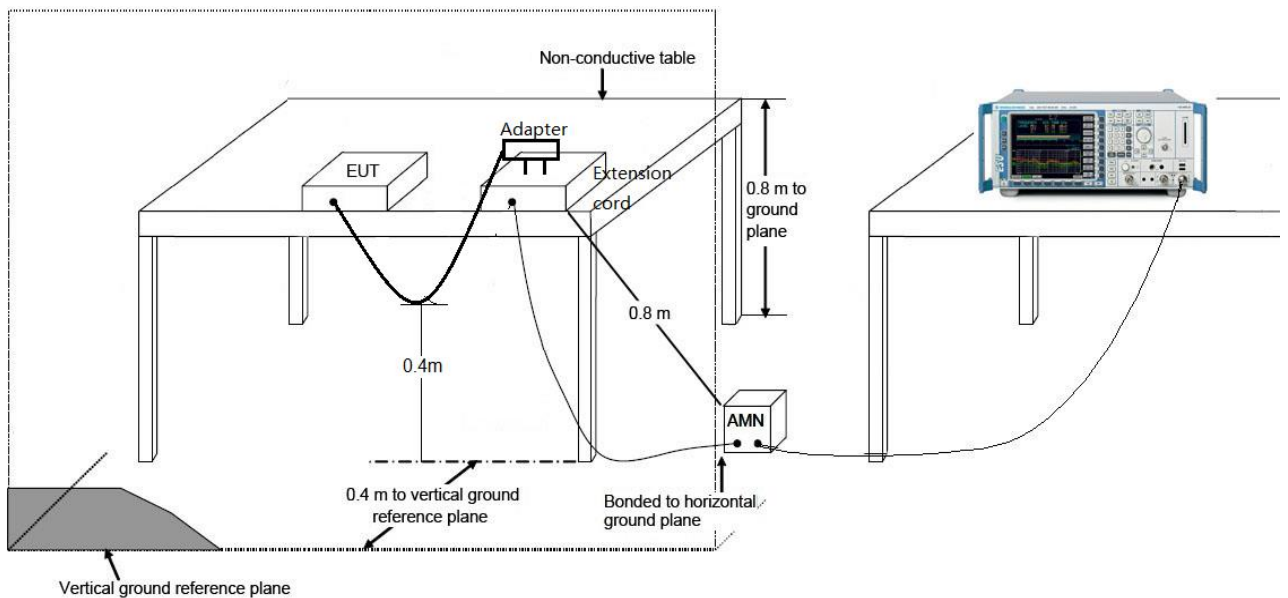

### 7.8.3. Test Result

EUT	BE11000 Ceiling Mount Wi-Fi 7 Access Point	Date of Test	2024-07-02
Factor	CE_ENV216-L1 (Filter ON)	Temp. / Humidity	27.1°C /50%
Polarity	Line1	Site / Test Engineer	SR2 / Will
Test Mode	802.11n-20MHz_TX_CH 6_ANT 0+1	Test Voltage	AC 120V/60Hz

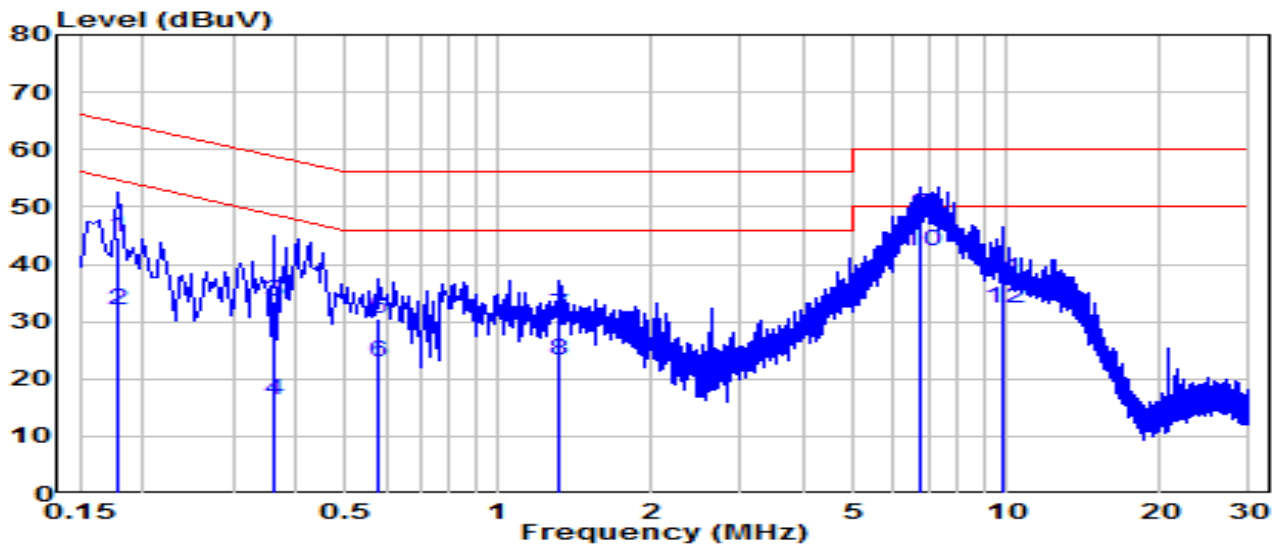

No	Frequency (MHz)	Reading (dBUV)	C.F (dB)	Measurement (dBUV)	Margin (dB)	Limit (dBUV)	Remark (QP/PK/AV)
1	0.177	35.19	9.63	44.82	-19.81	64.63	QP
2	0.177	22.45	9.63	32.08	-22.55	54.63	Average
3	0.361	23.85	9.64	33.49	-25.20	58.69	QP
4	0.361	6.61	9.64	16.26	-32.44	48.69	Average
5	0.577	20.89	9.66	30.54	-25.46	56.00	QP
6	0.577	13.43	9.66	23.08	-22.92	46.00	Average
7	1.320	21.36	9.69	31.05	-24.95	56.00	QP
8	1.320	13.50	9.69	23.19	-22.81	46.00	Average
9	* 6.787	38.68	9.79	48.47	-11.53	60.00	QP
10	* 6.787	32.37	9.79	42.16	-7.84	50.00	Average
11	9.833	27.60	9.87	37.47	-22.53	60.00	QP
12	9.833	22.55	9.87	32.42	-17.58	50.00	Average

Note:

1. " \*", means this data is the worst emission level.
2. C.F (Correction Factor) = LISN Factor (dB)+ Cable Loss (dB).
3. Measurement (dBUV) = Reading(dBUV) + C.F (Correction Factor).

EUT	BE11000 Ceiling Mount Wi-Fi 7 Access Point	Date of Test	2024-07-02
Factor	CE_ENV216-N (Filter ON)	Temp. / Humidity	27.1°C /50%
Polarity	Neutral	Site / Test Engineer	SR2 / Will
Test Mode	802.11n-20MHz_TX_CH 6_ANT 0+1	Test Voltage	AC 120V/60Hz

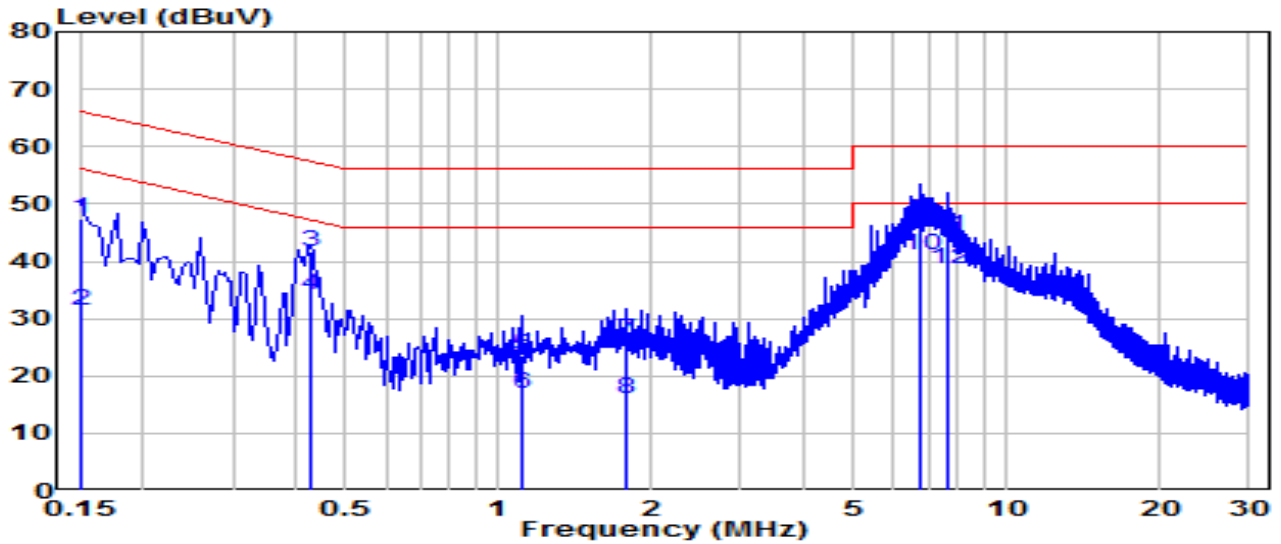

No	Frequency (MHz)	Reading (dBuV)	C.F (dB)	Measurement (dBuV)	Margin (dB)	Limit (dBuV)	Remark (QP/PK/AV)
1	0.150	37.68	9.63	47.31	-18.69	66.00	QP
2	0.150	21.68	9.63	31.31	-24.69	56.00	Average
3	0.424	32.07	9.65	41.71	-15.65	57.36	QP
4	0.424	24.50	9.65	34.15	-13.21	47.36	Average
5	1.113	14.00	9.68	23.68	-32.32	56.00	QP
6	1.113	7.24	9.68	16.93	-29.07	46.00	Average
7	1.774	16.56	9.70	26.27	-29.73	56.00	QP
8	1.774	6.42	9.70	16.12	-29.88	46.00	Average
9	* 6.796	37.27	9.81	47.08	-12.92	60.00	QP
10	* 6.796	31.13	9.81	40.94	-9.06	50.00	Average
11	7.628	34.59	9.83	44.42	-15.58	60.00	QP
12	7.628	28.84	9.83	38.67	-11.33	50.00	Average

Note:

1. " \*", means this data is the worst emission level.
2. C.F (Correction Factor) = LISN Factor (dB)+ Cable Loss (dB).
3. Measurement (dBuV) = Reading(dBuV) + C.F (Correction Factor).

EUT	BE11000 Ceiling Mount Wi-Fi 7 Access Point	Date of Test	2024-07-02
Factor	CE_ENV216-L1 (Filter ON)	Temp. / Humidity	27.1°C /50%
Polarity	Line1	Site / Test Engineer	SR2 / Will
Test Mode	802.11n-20MHz_TX_CH 6_ANT 0+1	Test Voltage	AC 240V/60Hz

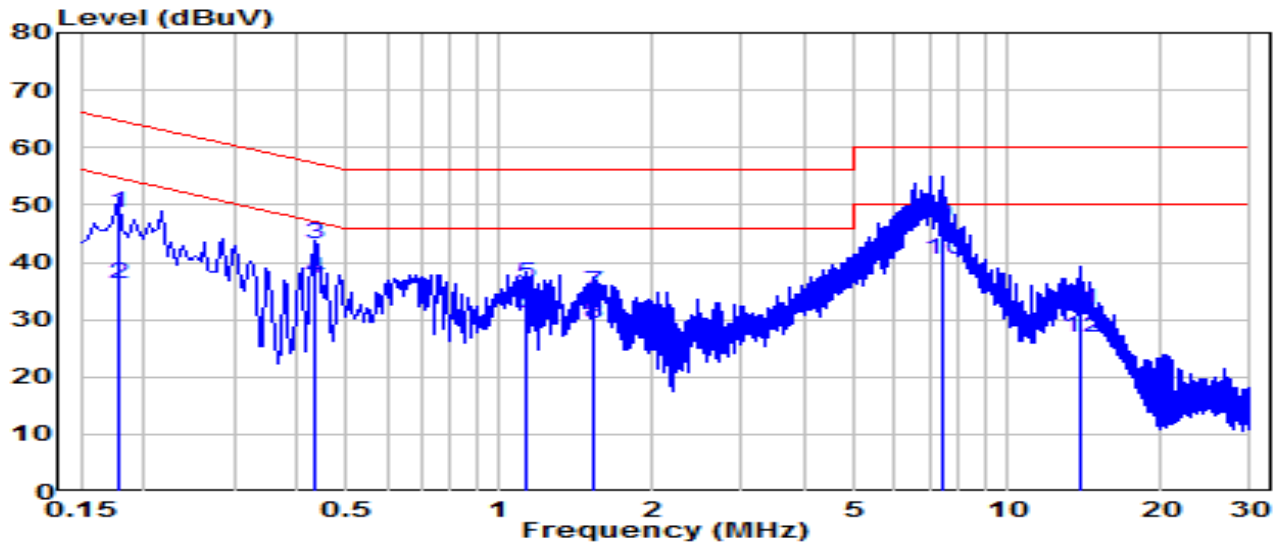

No	Frequency (MHz)	Reading (dBuV)	C.F (dB)	Measurement (dBuV)	Margin (dB)	Limit (dBuV)	Remark (QP/PK/AV)
1	0.177	38.94	9.63	48.57	-16.06	64.63	QP
2	0.177	26.53	9.63	36.16	-18.47	54.63	Average
3	0.433	33.50	9.65	43.15	-14.03	57.19	QP
4	0.433	27.56	9.65	37.20	-9.98	47.19	Average
5	1.135	26.65	9.68	36.34	-19.66	56.00	QP
6	1.135	21.54	9.68	31.22	-14.78	46.00	Average
7	1.540	25.11	9.69	34.80	-21.20	56.00	QP
8	1.540	19.58	9.69	29.27	-16.73	46.00	Average
9	*	7.417	9.81	46.34	-13.66	60.00	QP
10	*	7.417	9.81	40.52	-9.48	50.00	Average
11	13.887	21.77	9.89	31.67	-28.33	60.00	QP
12	13.887	16.92	9.89	26.81	-23.19	50.00	Average

Note:

1. "\*" , means this data is the worst emission level.
2. C.F (Correction Factor) = LISN Factor (dB)+ Cable Loss (dB).
3. Measurement (dBuV) = Reading(dBuV) + C.F (Correction Factor).

EUT	BE11000 Ceiling Mount Wi-Fi 7 Access Point	Date of Test	2024-07-02
Factor	CE_ENV216-N (Filter ON)	Temp. / Humidity	27.1°C /50%
Polarity	Neutral	Site / Test Engineer	SR2 / Will
Test Mode	802.11n-20MHz_TX_CH 6_ANT 0+1	Test Voltage	AC 240V/60Hz

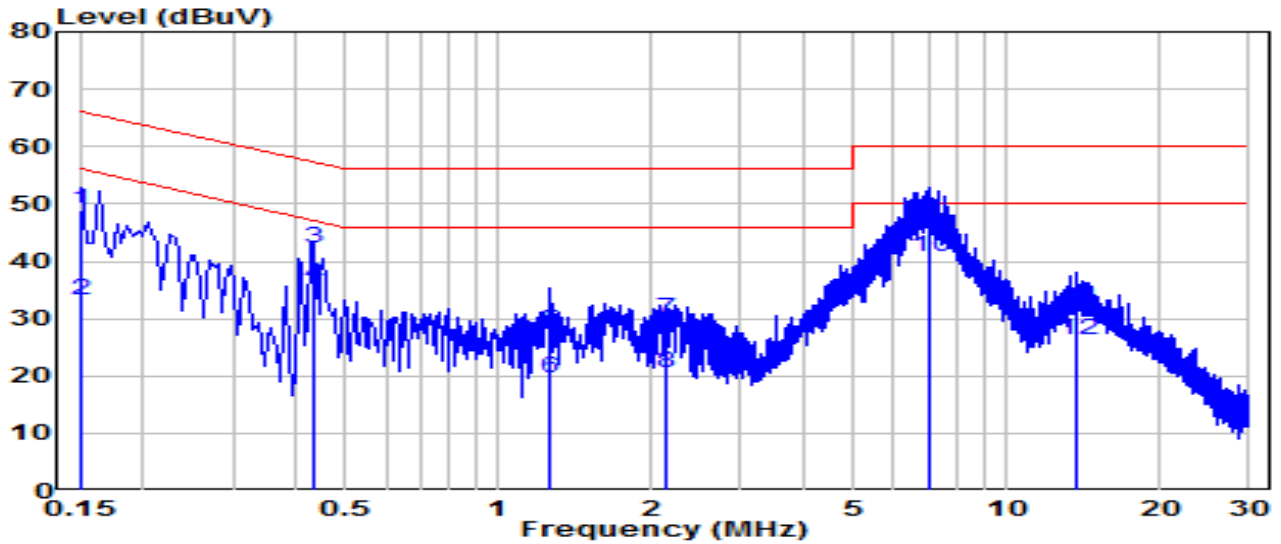

No	Frequency (MHz)	Reading (dBuV)	C.F (dB)	Measurement (dBuV)	Margin (dB)	Limit (dBuV)	Remark (QP/PK/AV)
1	0.150	39.26	9.63	48.89	-17.11	66.00	QP
2	0.150	23.43	9.63	33.06	-22.94	56.00	Average
3	0.433	32.68	9.65	42.33	-14.86	57.19	QP
4	0.433	26.25	9.65	35.89	-11.29	47.19	Average
5	1.261	18.05	9.69	27.73	-28.27	56.00	QP
6	1.261	9.90	9.69	19.59	-26.41	46.00	Average
7	2.139	20.03	9.71	29.74	-26.26	56.00	QP
8	2.139	10.78	9.71	20.50	-25.50	46.00	Average
9	* 7.088	37.11	9.81	46.92	-13.08	60.00	QP
10	* 7.088	31.04	9.81	40.85	-9.15	50.00	Average
11	13.788	21.77	9.93	31.70	-28.30	60.00	QP
12	13.788	16.27	9.93	26.19	-23.81	50.00	Average

Note:

1. " \*", means this data is the worst emission level.
2. C.F (Correction Factor) = LISN Factor (dB)+ Cable Loss (dB).
3. Measurement (dBuV) = Reading(dBuV) + C.F (Correction Factor).

## 8. CONCLUSION

The data collected relate only the item(s) tested and show that the device is compliance with Part 15C of the FCC Rules.

## **Appendix A : Test Setup Photograph**

Refer to “2405TW0113-UT” file.

## **Appendix B : External Photograph**

Refer to “2405TW0113-UE” file.

## **Appendix C : Internal Photograph**

Refer to “2405TW0113-UI” file.

————— The End —————