



RF MEASUREMENT REPORT

FCC ID : 2BCGWEAP772V2
Applicant : TP-LINK CORPORATION PTE. LTD.
Application Type : Certification
Product : BE11000 Ceiling Mount Wi-Fi 7 Access Point
Model No. : EAP772
Brand Name : tp-link
FCC Classification : Digital Transmission System (DTS)
FCC Rule Part(s) : Part 15.247
Test Procedure(s) : ANSI C63.10-2013
Received Date : May 21, 2024
Test Date : May 28, 2024~July 2, 2024

Tested By : Owen Tsai
(Owen Tsai)
Reviewed By : Paddy Chen
(Paddy Chen)
Approved By : Chenz Ker
(Chenz Ker)



The test results only relate to the tested sample.
This equipment has been shown to be capable of compliance with the applicable technical standards as indicated in the measurement report and was tested in accordance with the measurement procedures specified in ANSI C63.10. Test results reported herein relate only to the item(s) tested.
The test report shall not be reproduced except in full without the written approval of MRT Technology (Taiwan) Co., Ltd.

Revision History

| Report No. | Version | Description | Issue Date | Note |
|---------------|---------|-----------------|------------|-------|
| 2405TW0113-U2 | 1.0 | Original Report | 2024-08-06 | Valid |
| | | | | |

CONTENTS

| Description | Page |
|--|-----------|
| 1. INTRODUCTION | 6 |
| 1.1. Scope..... | 6 |
| 1.2. MRT Test Location..... | 6 |
| 2. PRODUCT INFORMATION | 7 |
| 2.1. Equipment Description | 7 |
| 2.2. Product Specification Subjective to this Standard..... | 7 |
| 2.3. Test Mode..... | 7 |
| 2.4. Operation Frequency / Channel List..... | 8 |
| 2.5. Test Configuration..... | 9 |
| 2.6. Test System Details | 9 |
| 2.7. Test Software..... | 10 |
| 2.8. Applied Standards..... | 10 |
| 2.9. Duty Cycle..... | 10 |
| 2.10. EMI Suppression Device(s)/Modifications | 11 |
| 2.11. Labeling Requirements | 11 |
| 3. DESCRIPTION of TEST | 12 |
| 3.1. Evaluation Procedure..... | 12 |
| 3.2. AC Line Conducted Emissions | 12 |
| 3.3. Radiated Emissions | 13 |
| 4. ANTENNA REQUIREMENTS..... | 14 |
| 5. TEST EQUIPMENT CALIBRATION DATE..... | 15 |
| 6. MEASUREMENT UNCERTAINTY..... | 16 |
| 7. TEST RESULT | 17 |
| 7.1. Summary..... | 17 |
| 7.2. 6dB Bandwidth Measurement | 18 |
| 7.2.1. Test Limit..... | 18 |
| 7.2.2. Test Procedure used | 18 |
| 7.2.3. Test Setting | 18 |
| 7.2.4. Test Setup..... | 18 |
| 7.2.5. Test Result | 19 |
| 7.3. Output Power Measurement..... | 23 |
| 7.3.1. Test Limit..... | 23 |
| 7.3.2. Test Procedure Used..... | 23 |
| 7.3.3. Test Setting | 23 |
| 7.3.4. Test Setup..... | 23 |
| 7.3.5. Test Result of Output Power..... | 24 |
| 7.4. Power Spectral Density Measurement | 25 |
| 7.4.1. Test Limit..... | 25 |
| 7.4.2. Test Procedure Used..... | 25 |
| 7.4.3. Test Setting | 25 |
| 7.4.4. Test Setup..... | 26 |
| 7.4.5. Test Result | 27 |
| 7.5. Out-of-Band Spurious Emissions Emissions Measurement..... | 31 |
| 7.5.1. Test Limit..... | 31 |

| | | |
|-----------|--|-----------|
| 7.5.2. | Test Procedure Used..... | 31 |
| 7.5.3. | Test Settting | 31 |
| 7.5.4. | Test Setup | 31 |
| 7.5.5. | Test Result | 32 |
| 7.6. | Radiated Spurious Emission Measurement..... | 36 |
| 7.6.1. | Test Limit..... | 36 |
| 7.6.2. | Test Procedure Used..... | 36 |
| 7.6.3. | Test Setting | 36 |
| 7.6.4. | Test Setup | 38 |
| 7.6.5. | Test Result | 40 |
| 7.7. | Radiated Restricted Band Edge Measurement..... | 62 |
| 7.7.1. | Test Limit..... | 62 |
| 7.7.2. | Test Procedure Used..... | 62 |
| 7.7.3. | Test Setting | 62 |
| 7.7.4. | Test Setup | 64 |
| 7.7.5. | Test Result | 65 |
| 7.8. | AC Conducted Emissions Measurement..... | 89 |
| 7.8.1. | Test Limit..... | 89 |
| 7.8.2. | Test Setup..... | 89 |
| 7.8.3. | Test Result | 90 |
| 8. | CONCLUSION | 94 |
| | Appendix A : Test Photograph | 95 |
| | Appendix B : External Photograph..... | 95 |
| | Appendix C : Internal Photograph | 95 |

General Information

| | |
|---------------------------------|--|
| Applicant | TP-LINK CORPORATION PTE. LTD. |
| Applicant Address | 7 Temasek Boulevard #29-03 Suntec Tower One, Singapore 038987 |
| Manufacturer | TP-LINK CORPORATION PTE. LTD. |
| Manufacturer Address | 7 Temasek Boulevard #29-03 Suntec Tower One, Singapore 038987 |
| Test Site | MRT Technology (Taiwan) Co., Ltd |
| Test Site Address | No. 38, Fuxing Second Rd., Guishan Dist., Taoyuan City 333, Taiwan (R.O.C) |
| MRT FCC Registration No. | 291082 |
| FCC Rule Part(s) | Part 15.247 |

Test Facility / Accreditations

1. MRT facility is a FCC registered (Reg. No. 291082) test facility with the site description report on file and is designated by the FCC as an Accredited Test Firm.
2. MRT facility is an IC registered (MRT Reg. No. 21723) test laboratory with the site description on file at Industry Canada.
3. MRT Lab is accredited to ISO 17025 by the Taiwan Accreditation Foundation (TAF Cert. No. 3261) in EMC, Telecommunications and Radio testing for FCC (Designation Number: TW3261), Industry Canada, EU and TELEC Rules.

1. INTRODUCTION

1.1. Scope

Measurement and determination of electromagnetic emissions (EMC) of radio frequency devices including intentional and/or unintentional radiators for compliance with the technical rules and regulations of the Federal Communications Commission and the Industry Canada Certification and Engineering Bureau.

1.2. MRT Test Location

The map below shows the location of the MRT LABORATORY, its proximity to the Taoyuan City. These measurement tests were conducted at the MRT Technology (Taiwan) Co., Ltd. Facility located at No.38, Fuxing 2nd Rd., Guishan Dist., Taoyuan City 33377, Taiwan (R.O.C).

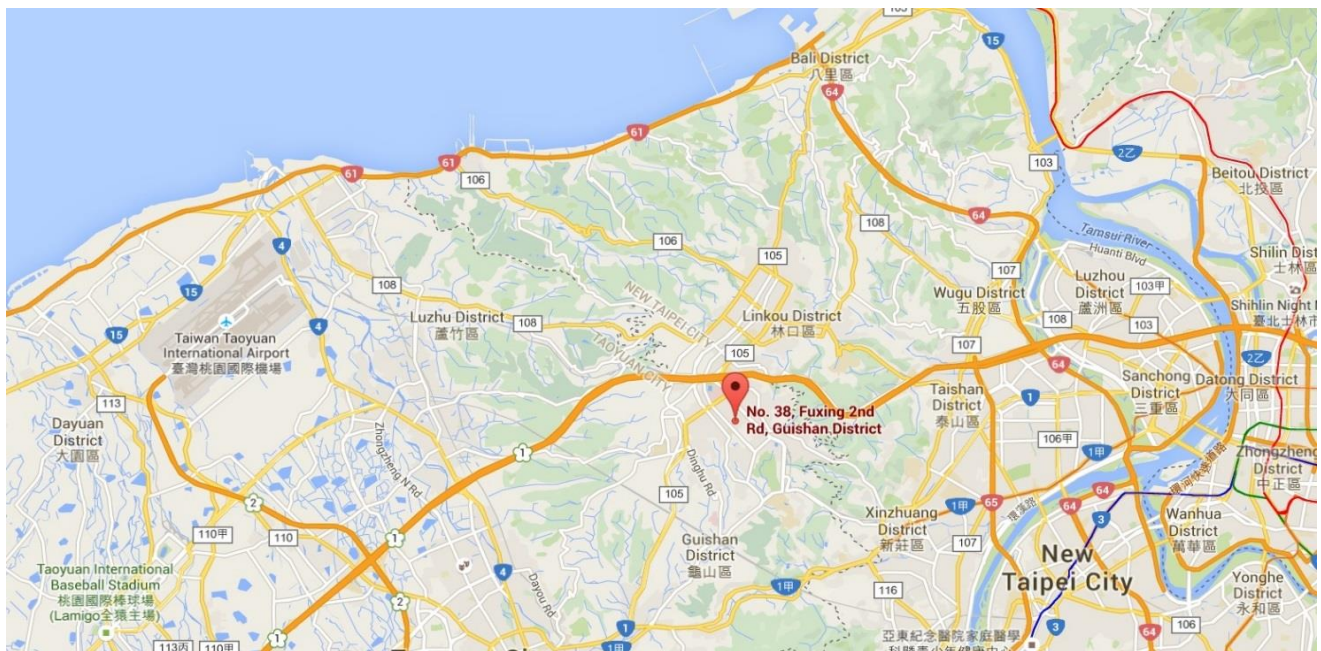

2. PRODUCT INFORMATION

2.1. Equipment Description

| | |
|-------------------------|---|
| Product Name | BE11000 Ceiling Mount Wi-Fi 7 Access Point |
| Model No. | EAP772 |
| Brand Name | tp-link |
| Bluetooth Specification | Bluetooth Mode: V5.2 Single mode |
| Wi-Fi Specification: | 802.11a/b/g/n/ac/ax/be |
| EUT Identification No.: | #1-1 (Conducted) #1-2 (Radiated) |
| Power Supply: | Power: 12V 2.5A 802.3at PoE: 42.5-57V 0.6A |

2.2. Product Specification Subjective to this Standard

| | |
|---------------------|--------------|
| Operating Frequency | 2402~2480MHz |
| Type of modulation | GFSK |
| Data Rate | 1Mbps |
| Antenna Type | PIFA Antenna |
| Antenna Gain | 3.0dBi |

2.3. Test Mode

| | |
|-----------|---|
| Test Mode | Mode 1: Transmit - LE (1Mbps) Mode 2: Transmit - LE (Coded S=2) Mode 3: Transmit - LE (Coded S=8) |
|-----------|---|

Note: Regarding to the operation frequency, the lowest, middle and highest frequency are selected to perform the test.

2.4. Operation Frequency / Channel List

| Channel | Frequency | Channel | Frequency | Channel | Frequency |
|---------|-----------|---------|-----------|---------|-----------|
| 00 | 2402 MHz | 01 | 2404 MHz | 02 | 2406 MHz |
| 03 | 2408 MHz | 04 | 2410 MHz | 05 | 2412 MHz |
| 06 | 2414 MHz | 07 | 2416 MHz | 08 | 2418 MHz |
| 09 | 2420 MHz | 10 | 2422 MHz | 11 | 2424 MHz |
| 12 | 2426 MHz | 13 | 2428 MHz | 14 | 2430 MHz |
| 15 | 2432 MHz | 16 | 2434 MHz | 17 | 2436 MHz |
| 18 | 2438 MHz | 19 | 2440 MHz | 20 | 2442 MHz |
| 21 | 2444 MHz | 22 | 2446 MHz | 23 | 2448 MHz |
| 24 | 2450 MHz | 25 | 2452 MHz | 26 | 2454 MHz |
| 27 | 2456 MHz | 28 | 2458 MHz | 29 | 2460 MHz |
| 30 | 2462 MHz | 31 | 2464 MHz | 32 | 2466 MHz |
| 33 | 2468 MHz | 34 | 2470 MHz | 35 | 2472 MHz |
| 36 | 2474 MHz | 37 | 2476 MHz | 38 | 2478 MHz |
| 39 | 2480 MHz | N/A | N/A | N/A | N/A |

2.5. Test Configuration

This device was tested per the guidance of ANSI C63.10-2013. ANSI C63.10-2013 was used to reference the appropriate EUT setup for radiated spurious emissions testing and AC line conducted testing.

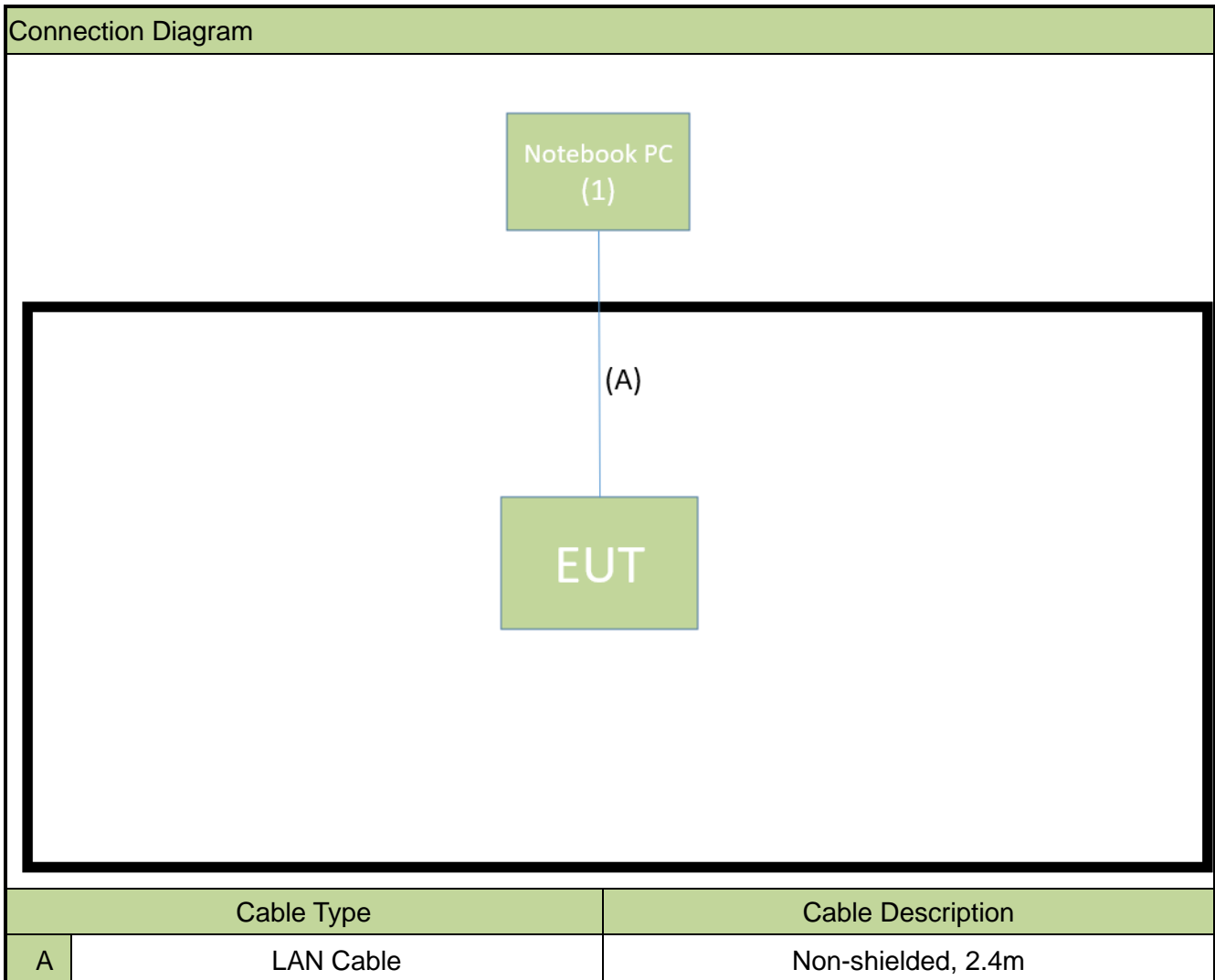

2.6. Test System Details

The types for all equipments, plus descriptions of all cables used in the tested system (including inserted cards) are:

| No. | Product | Brand | Model No. | Serial No. | Power Cord |
|-----|-------------|--------|-----------|------------|--------------------|
| 1 | Notebook PC | Lenovo | MP25ZAKY | N/A | Non-shielded, 0.8m |

2.7. Test Software

The test utility software used during testing was “Tera Term v4.98”.

2.8. Applied Standards

According to the specifications of the manufacturer, the EUT must comply with the requirements of the following standards:

- FCC Part 15.247
- KDB 558074 D01v05r02
- ANSI C63.10-2013

2.9. Duty Cycle

| Test Mode | Duty Cycle |
|---------------|------------|
| BLE-1Mbps | 19% |
| BLE-Coded S=2 | 40% |
| BLE-Coded S=8 | 61% |

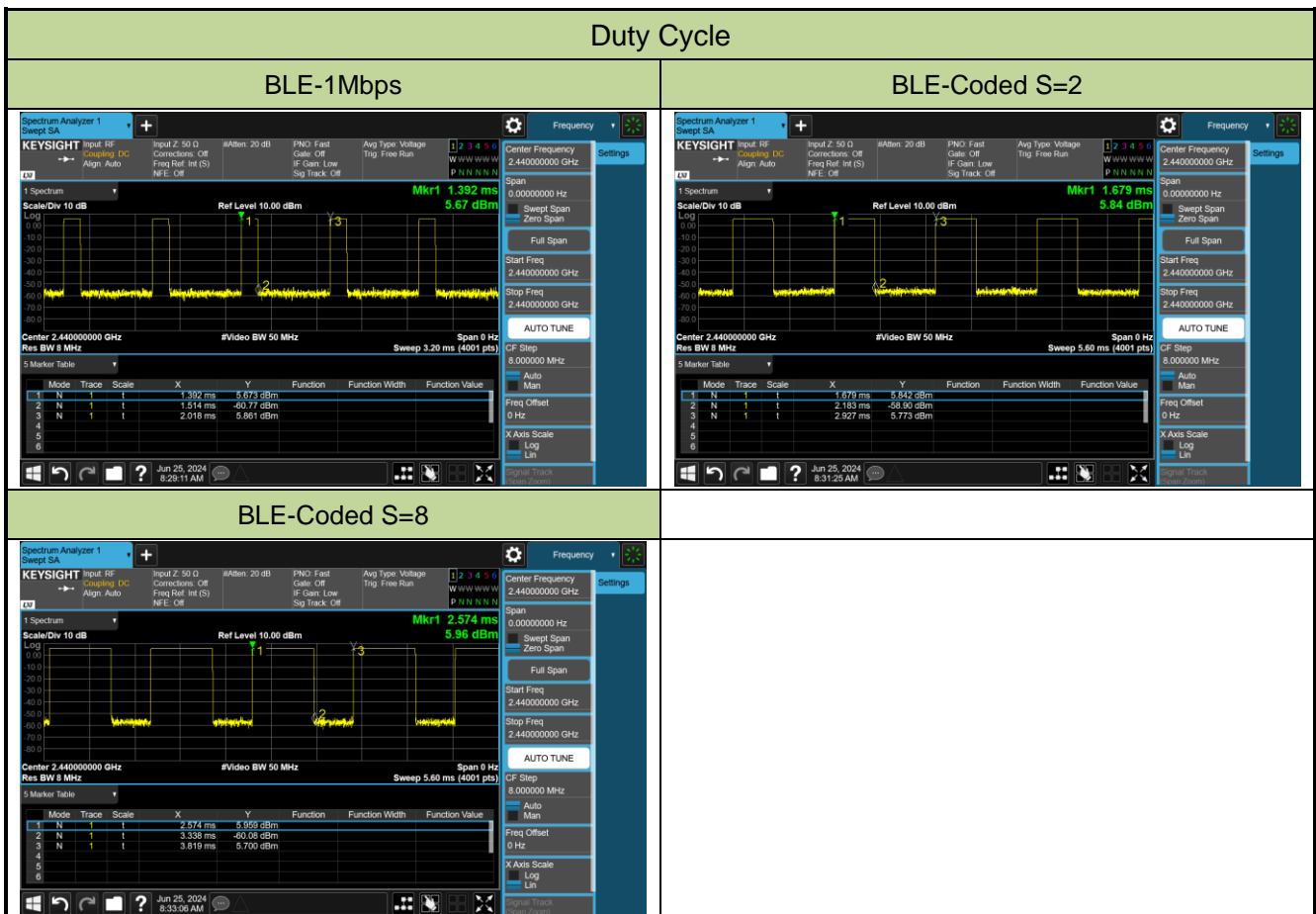

2.10. EMI Suppression Device(s)/Modifications

No EMI suppression device(s) were added and/or no modifications were made during testing.

2.11. Labeling Requirements

Per 2.1074 & 15.19; Docket 95-19

The label shall be permanently affixed at a conspicuous location on the device; instruction manual or pamphlet supplied to the user and be readily visible to the purchaser at the time of purchase.

However, when the device is so small wherein placement of the label with specified statement is not practical, only the FCC ID must be displayed on the device per Section 15.19(a)(5). Please see attachment for FCC ID label and label location.

3. DESCRIPTION of TEST

3.1. Evaluation Procedure

The measurement procedures described in the American National Standard for Testing Unlicensed Wireless Devices (ANSI C63.10-2013) was used in the measurement of the **BE11000 Ceiling Mount Wi-Fi 7 Access Point**.

Deviation from measurement procedure.....None

3.2. AC Line Conducted Emissions

The line-conducted facility is located inside an 9'x4'x3' shielded enclosure. A 1m x 2m wooden table 80cm high is placed 40cm away from the vertical wall and 80cm away from the sidewall of the shielded room. Two 10kHz-30MHz, 50Ω/50uH Line-Impedance Stabilization Networks (LISNs) are bonded to the shielded room floor. Power to the LISNs is filtered by external high-current high-insertion loss power line filters. These filters attenuate ambient signal noise from entering the measurement lines. These filters are also bonded to the shielded enclosure.

The EUT is powered from one LISN and the support equipment is powered from the second LISN. All interconnecting cables more than 1 meter were shortened to a 1 meter length by non-inductive bundling (serpentine fashion) and draped over the back edge of the test table. All cables were at least 40cm above the horizontal reference ground-plane. Power cables for support equipment were routed down to the second LISN while ensuring that that cables were not draped over the second LISN.

Sufficient time for the EUT, support equipment, and test equipment was allowed in order for them to warm up to their normal operating condition. The RF output of the LISN was connected to the receiver and exploratory measurements were made to determine the frequencies producing the maximum emission from the EUT. The receiver was scanned from 150kHz to 30MHz. The detector function was set to peak mode for exploratory measurements while the bandwidth of the analyzer was set to 9kHz. The EUT, support equipment, and interconnecting cables were arranged and manipulated to maximize each emission. Each emission was also maximized by varying: power lines, the mode of operation or data exchange speed, or support equipment which determined the worst-case emission. Once the worst case emissions have been identified, the one EUT cable configuration/arrangement and mode of operation that produced these emissions are used for final measurements on the same test site. The analyzer is set to CISPR quasi-peak and average detectors with a 9kHz resolution bandwidth for final measurements.

An extension cord was used to connect to a single LISN which powered by EUT. The extension cord was calibrated with LISN, the impedance and insertion loss are compliance with the requirements as stated in ANSI C63.10-2013.

Line conducted emissions test results are shown in Section 7.8.

3.3. Radiated Emissions

The radiated test facilities consisted of an indoor 3 meter semi-anechoic chamber used for final measurements and exploratory measurements, when necessary. The measurement area is contained within the semi-anechoic chamber which is shielded from any ambient interference. For measurements above 1GHz absorbers are arranged on the floor between the turn table and the antenna mast in such a way so as to maximize the reduction of reflections. For measurements below 1GHz, the absorbers are removed. A MF Model 210SS turntable is used for radiated measurement. It is a continuously rotatable, remote controlled, metallic turntable and 2 meters (6.56 ft.) in diameter. The turn table is flush with the raised floor of the chamber in order to maintain its function as a ground plane. An 80cm high PVC support structure is placed on top of the turntable.

For all measurements, the spectrum was scanned through all EUT azimuths and from 1 to 4 meter receive antenna height using a broadband antenna from 30MHz up to the upper frequency shown in 15.33(b)(1) depending on the highest frequency generated or used in the device or on which the device operates or tunes. For frequencies above 1GHz, linearly polarized double ridge horn antennas were used. For frequencies below 30MHz, a calibrated loop antenna was used. When exploratory measurements were necessary, they were performed at 1 meter test distance inside the semi-anechoic chamber using broadband antennas, broadband amplifiers, and spectrum analyzers to determine the frequencies and modes producing the maximum emissions. Sufficient time for the EUT, support equipment, and test equipment was allowed in order for them to warm up to their normal operating condition. The test set-up for frequencies below 1GHz was placed on top of the 0.8 meter high, 1 x 1.5 meter table; and test set-up for frequencies 1-40GHz was placed on top of the 1.5 meter high, 1 x 1.5 meter table. The EUT, support equipment, and interconnecting cables were arranged and manipulated to maximize each emission. Appropriate precaution was taken to ensure that all emissions from the EUT were maximized and investigated. The system configuration, clock speed, mode of operation or video resolution, if applicable, turntable azimuth, and receive antenna height was noted for each frequency found.

Final measurements were made in the semi-anechoic chamber using calibrated, linearly polarized broadband and horn antennas. The test setup was configured to the setup that produced the worst case emissions. The spectrum analyzer was set to investigate all frequencies required for testing to compare the highest radiated disturbances with respect to the specified limits. The turntable containing the EUT was rotated through 360 degrees and the height of the receive antenna was varied 1 to 4 meters and stopped at the azimuth and height producing the maximum emission. Each emission was maximized by changing the orientation of the EUT through three orthogonal planes and changing the polarity of the receive antenna, which produced the worst-case emissions. According to 3dB Beam-Width of horn antenna, the horn antenna should be always directed to the EUT when rising height.

Radiated emissions test results are shown in Section 7.6 & 7.7.

4. ANTENNA REQUIREMENTS

Excerpt from §15.203 of the FCC Rules/Regulations:

“An intentional radiator antenna shall be designed to ensure that no antenna other than that furnished by the responsible party can be used with the device. The use of a permanently attached antenna or of an antenna that uses a unique coupling to the intentional radiator shall be considered sufficient to comply with the provisions of this section.”

- The antenna of the **BE11000 Ceiling Mount Wi-Fi 7 Access Point**, is permanently attached.
- There are no provisions for connection to an external antenna.

Conclusion:

The EUT unit complies with the requirement of §15.203.

5. TEST EQUIPMENT CALIBRATION DATE

Conducted Emissions – SR2

| Instrument | Manufacturer | Type No. | Asset No. | Cali. Interval | Cali. Due Date |
|--------------------|--------------|-----------------------------|-------------|----------------|----------------|
| Two-Line V-Network | R&S | ENV216 | MRTTWA00020 | 1 year | 2025/4/21 |
| Cable | Rosnol | N1C50-RG400-B 1C50-500CM | MRTTWE00013 | 1 year | 2025/6/14 |
| EMI Test Receiver | R&S | ESR3 | MRTTWA00009 | 1 year | 2025/3/5 |

Radiated Emissions – AC2

| Instrument | Manufacturer | Type No. | Asset No. | Cali. Interval | Cali. Due Date |
|----------------------------|--------------------------------|-----------------------|-------------|----------------|----------------|
| Active Loop Antenna | SCHWARZBECK | FMZB 1519B | MRTTWA00002 | 1 year | 2025/5/7 |
| Broadband TRILOG Antenna | SCHWARZBECK | VULB 9162 | MRTTWA00001 | 1 year | 2024/10/31 |
| Broadband Hornantenna | RFSPIN | DRH18-E | MRTTWA00087 | 1 year | 2025/5/20 |
| Broadband Preamplicifier | EMC Instruments corporation | EMC118A45SE | MRTTWA00088 | 1 year | 2025/5/14 |
| Breitband Hornantenna | SCHWARZBECK | BBHA 9170 | MRTTWA00004 | 1 year | 2025/3/26 |
| Broadband Amplifier | SCHWARZBECK | BBV 9721 | MRTTWA00006 | 1 year | 2025/3/21 |
| EMI Test Receiver | R&S | ESR3 | MRTTWA00009 | 1 year | 2025/3/5 |
| Signal Analyzer | R&S | FSVA3044 | MRTTWA00092 | 1 year | 2025/6/20 |
| Antenna Cable | HUBERSUHNER | SF106 | MRTTWE00034 | 1 year | 2025/6/25 |
| Cable | HUBERSUHNER | EMC105-NM-NM -3000 | MRTTWE00035 | 1 year | 2025/6/25 |
| Temperature/Humidity Meter | TFA | 35.1083 | MRTTWA00050 | 1 year | 2025/6/2 |

Conducted Test Equipment – SR5

| Instrument | Manufacturer | Type No. | Asset No. | Cali. Interval | Cali. Due Date |
|---------------------------|--------------|----------|-------------|----------------|----------------|
| EXA Signal Analyzer | KEYSIGHT | N9010A | MRTTWA00012 | 1 year | 2024/10/17 |
| EXA Signal Analyzer | KEYSIGHT | N9010B | MRTTWA00074 | 1 year | 2024/7/19 |
| USB Wideband Power Sensor | KEYSIGHT | U2021XA | MRTTWA00015 | 1 year | 2025/3/12 |

Test Software

| Software | Version | Function |
|----------|-----------|-------------------|
| e3 | 9.160520a | EMI Test Software |
| EMI | V3 | EMI Test Software |

6. MEASUREMENT UNCERTAINTY

Where relevant, the following test uncertainty levels have been estimated for tests performed on the EUT as specified in CISPR 16-4-2. This uncertainty represents an expanded uncertainty expressed at approximately the 95% confidence level using a coverage factor of $k = 2$.

| |
|---|
| Conducted Emission- Power Line |
| Measuring Uncertainty for a Level of Confidence of 95% ($U=2Uc(y)$): 0.15MHz~30MHz: $\pm 2.53\text{dB}$ |
| Radiated Spurious Emission |
| Measuring Uncertainty for a Level of Confidence of 95% ($U=2Uc(y)$): 9kHz~30MHz: $\pm 3.92\text{dB}$ 30MHz~1GHz: $\pm 4.25\text{dB}$ 1GHz~18GHz: $\pm 4.40\text{dB}$ 18GHz~40GHz: $\pm 4.45\text{dB}$ |
| Frequency Error |
| Measuring Uncertainty for a Level of Confidence of 95% ($U=2Uc(y)$): $\pm 78.4\text{Hz}$ |
| Conducted Power |
| Measuring Uncertainty for a Level of Confidence of 95% ($U=2Uc(y)$): $\pm 0.84\text{dB}$ |
| Conducted Spurious Emission |
| Measuring Uncertainty for a Level of Confidence of 95% ($U=2Uc(y)$): $\pm 2.65\text{ dB}$ |
| Occupied Bandwidth |
| Measuring Uncertainty for a Level of Confidence of 95% ($U=2Uc(y)$): $\pm 3.3\%$ |
| Temp. / Humidity |
| Measuring Uncertainty for a Level of Confidence of 95% ($U=2Uc(y)$): $\pm 0.82^\circ\text{C}/ \pm 3\%$ |
| DC Voltage |
| Measuring Uncertainty for a Level of Confidence of 95% ($U=2Uc(y)$): $\pm 0.3\%$ |

7. TEST RESULT

7.1. Summary

| FCC Part Section(s) | Test Description | Test Limit | Test Condition | Test Result | Reference |
|---------------------|--|---|-------------------|-------------|-------------|
| 15.247(a)(2) | 6dB Bandwidth | $\geq 500\text{kHz}$ | Conducted | Pass | Section 7.2 |
| 15.247(b)(3) | Output Power | $\leq 30.00\text{dBm}$ | | Pass | Section 7.3 |
| 15.247(e) | Power Spectral Density | $\leq 8.00\text{dBm}/3\text{kHz}$ | | Pass | Section 7.4 |
| 15.247(d) | Out-of-Band Emissions | Conducted $\geq 30\text{dBc}$ | | Pass | Section 7.5 |
| 15.205 15.209 | Spurious Emission | < FCC 15.209 limits | Radiated | Pass | Section 7.6 |
| 15.205 15.209 | Band Edge Measurement | $\leq 74\text{dBuV/m(Peak)}$ $\leq 54\text{dBuV/m(Average)}$ | | Pass | Section 7.7 |
| 15.207 | AC Conducted Emissions 150kHz - 30MHz | < FCC 15.207 limits | Line Conducted | Pass | Section 7.8 |

Notes:

- 1) Determining compliance is based on the test results met the regulation limits or requirements declared by clients, and the test results don't take into account the value of measurement uncertainty.
- 2) For radiated emission test, every axis (X, Y, Z) was also verified when applicable. The test results shown in the following sections represent the worst-case emissions.
- 3) The analyzer plots shown in this section were all taken with a correction table loaded into the analyzer. The correction table was used to account for the losses of the cables and attenuators used as part of the system to connect the EUT to the analyzer at all frequencies of interest.

7.2. 6dB Bandwidth Measurement

7.2.1. Test Limit

The minimum 6dB bandwidth shall be at least 500 kHz.

7.2.2. Test Procedure used

ANSI C63.10 - 2013 Section 11.8

7.2.3. Test Setting

1. The Spectrum's automatic bandwidth measurement capability was used to perform the 6dB bandwidth measurement. The "X" dB bandwidth parameter was set to $X = 6$. The bandwidth measurement was not influenced by any intermediate power nulls in the fundamental emission.
2. Set RBW = 100 kHz
3. $VBW \geq 3 \times RBW$
4. Detector = Peak
5. Trace mode = max hold
6. Sweep = auto couple
7. Allow the trace was allowed to stabilize

7.2.4. Test Setup

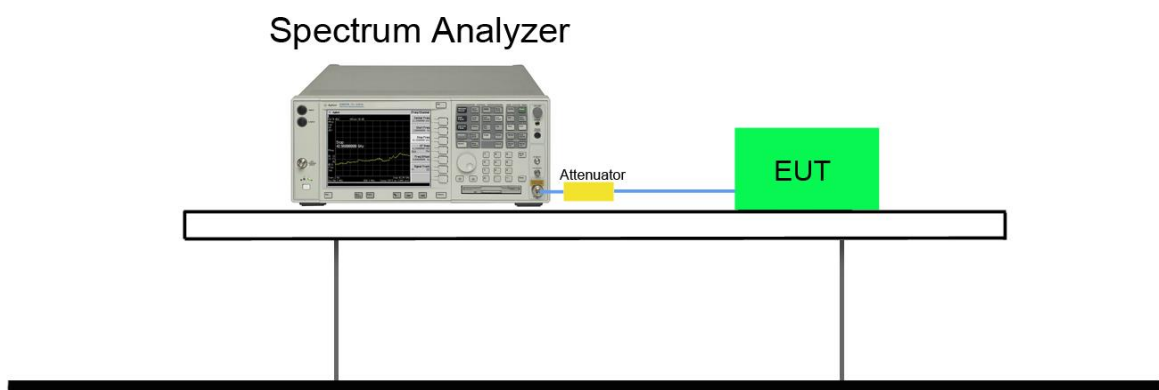

7.2.5. Test Result

| | | | |
|---------------|--|-------------------|-----------|
| Product | BE11000 Ceiling Mount Wi-Fi 7 Access Point | Temperature | 25°C |
| Test Engineer | Xuan Yu | Relative Humidity | 54% |
| Test Site | SR6 | Test Date | 2024/6/25 |

| Test Mode | Channel No. | Frequency (MHz) | 6dB Bandwidth (MHz) | Limit (MHz) | Result |
|-----------------|-------------|-----------------|---------------------|-------------|--------|
| LE 1Mbps | 00 | 2402 | 0.5035 | ≥ 0.5 | Pass |
| | 19 | 2440 | 0.5031 | ≥ 0.5 | Pass |
| | 39 | 2480 | 0.5075 | ≥ 0.5 | Pass |
| LE Coded S=2 | 00 | 2402 | 0.6497 | ≥ 0.5 | Pass |
| | 19 | 2440 | 0.6533 | ≥ 0.5 | Pass |
| | 39 | 2480 | 0.6452 | ≥ 0.5 | Pass |
| LE Coded S=8 | 00 | 2402 | 0.6019 | ≥ 0.5 | Pass |
| | 19 | 2440 | 0.5956 | ≥ 0.5 | Pass |
| | 39 | 2480 | 0.5957 | ≥ 0.5 | Pass |

LE 1Mbps

LE CH00 (2402MHz)



LE CH19 (2440MHz)

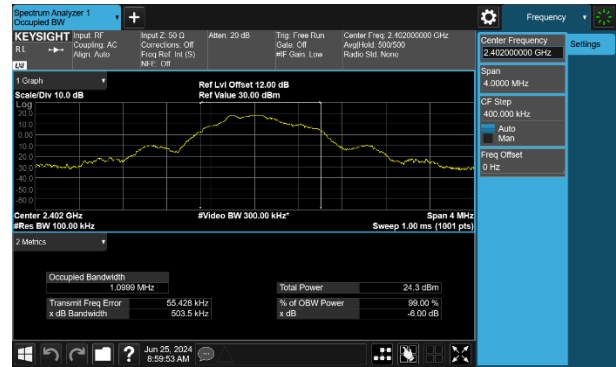

LE CH39 (2480MHz)

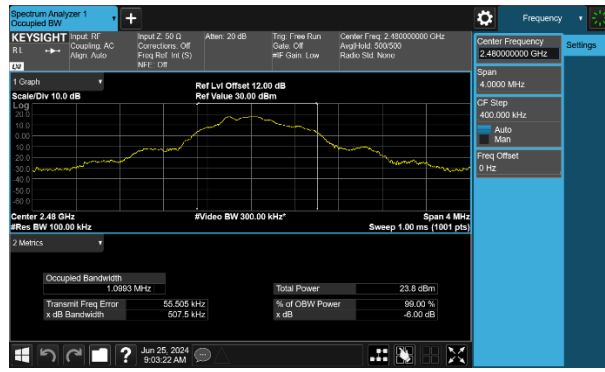

LE Coded S=2

LE CH00 (2402MHz)

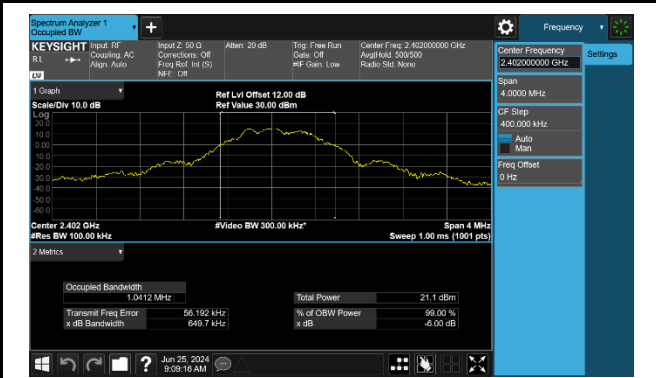

LE CH19 (2440MHz)

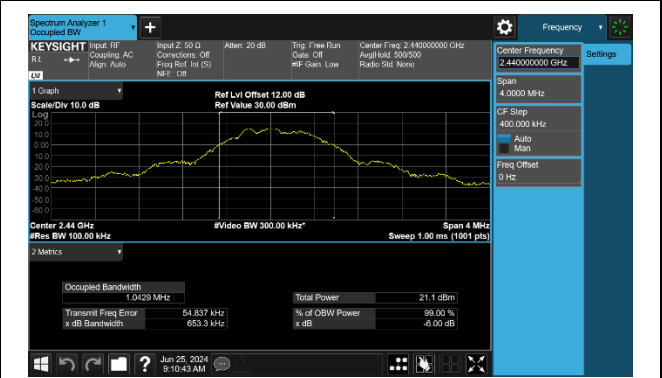

LE CH39 (2480MHz)

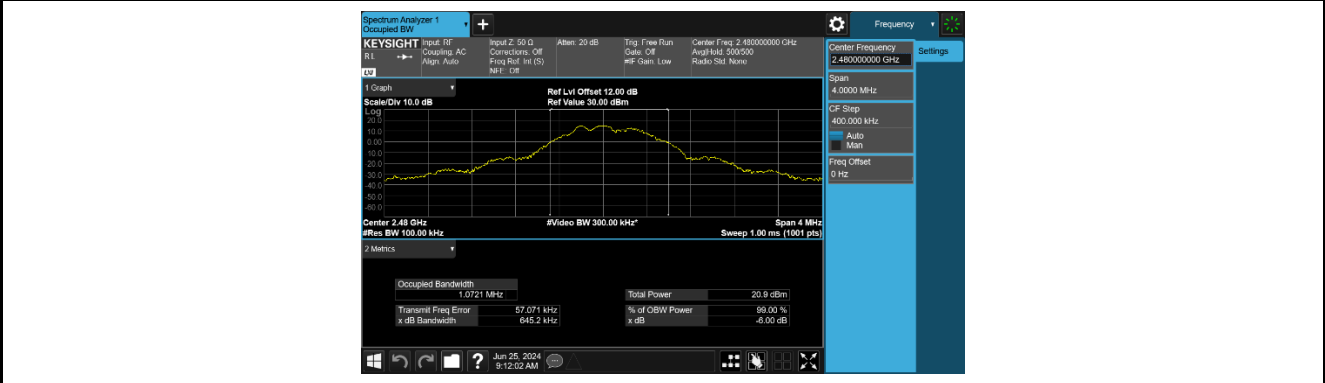

LE Coded S=8

LE CH00 (2402MHz)

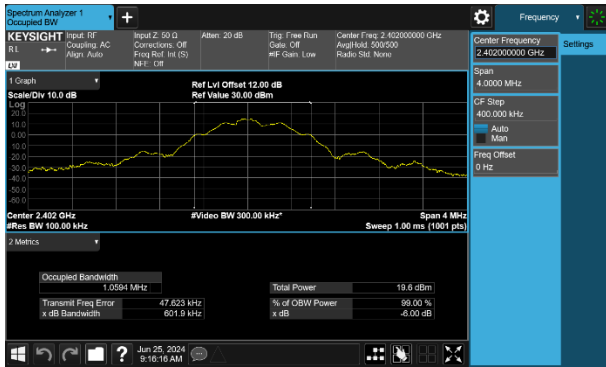

LE CH19 (2440MHz)

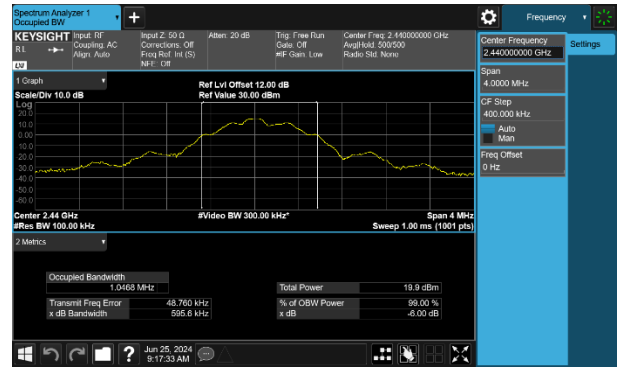

LE CH39 (2480MHz)

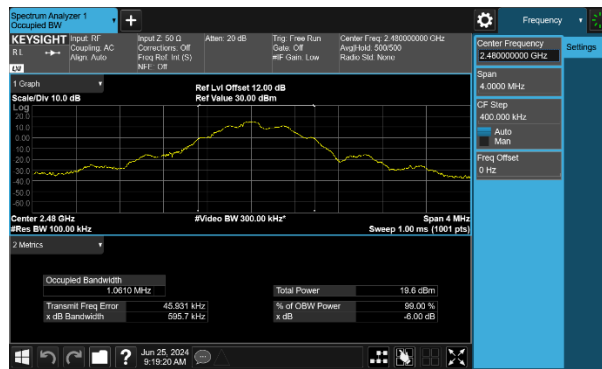

7.3. Output Power Measurement

7.3.1. Test Limit

The maximum out power shall be less 1 Watt (30dBm).

The conducted output power limit specified in paragraph FCC Part 15.247(b) of this section is based on the use of antennas with directional gains that do not exceed 6 dBi. If transmitting antennas of directional gain greater than 6 dBi are used, the conducted output power from the intentional radiator shall be reduced below the stated values in paragraphs FCC Part 15.247(b)(3) of this section, as appropriate, by the amount in dB that the directional gain of the antenna exceeds 6 dBi.

7.3.2. Test Procedure Used

ANSI C63.10 - 2013 Section 11.9.2.3.2

7.3.3. Test Setting

Average Power Measurement

Average power measurements were performed only when the EUT was transmitting at its maximum power control level using a broadband power meter with a pulse sensor. The power meter implemented triggering and gating capabilities which were set up such that power measurements were recorded only during the ON time of the transmitter. The trace was averaged over 100 traces to obtain the final measured average power.

7.3.4. Test Setup

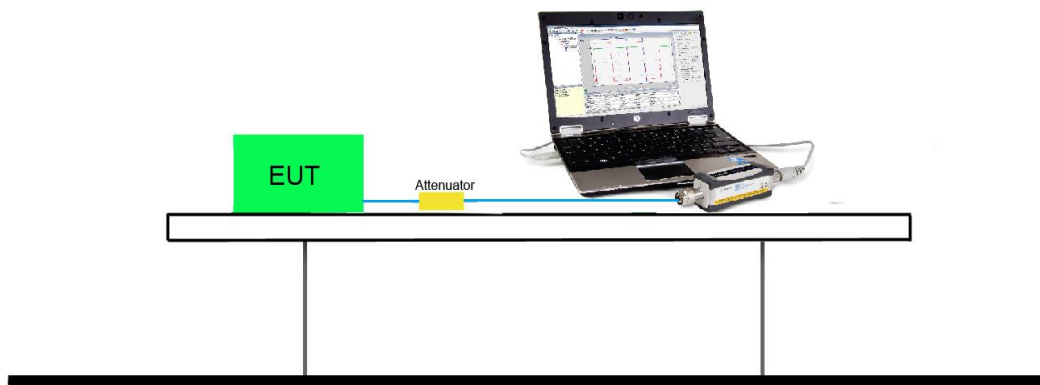

7.3.5. Test Result of Output Power

| | | | |
|---------------|--|-------------------|-----------|
| Product | BE11000 Ceiling Mount Wi-Fi 7 Access Point | Temperature | 25°C |
| Test Engineer | Xuan Yu | Relative Humidity | 54% |
| Test Site | SR6 | Test Date | 2024/6/25 |

| Test Mode | Channel No. | Frequency (MHz) | Average Power (dBm) | Power Limit (dBm) |
|-----------------|-------------|-----------------|---------------------|-------------------|
| LE 1Mbps | 00 | 2402 | 18.47 | < 30 |
| | 19 | 2440 | 18.18 | < 30 |
| | 39 | 2480 | 17.97 | < 30 |
| LE Coded S=2 | 00 | 2402 | 14.87 | < 30 |
| | 19 | 2440 | 14.93 | < 30 |
| | 39 | 2480 | 14.82 | < 30 |
| LE Coded S=8 | 00 | 2402 | 14.82 | < 30 |
| | 19 | 2440 | 14.87 | < 30 |
| | 39 | 2480 | 14.78 | < 30 |

Note1: Output power = Reading value on power meter + cable loss.

Note2: Antenna Gain: 3.00dBi.

7.4. Power Spectral Density Measurement

7.4.1. Test Limit

The maximum permissible power spectral density is 8dBm in any 3 kHz band.

7.4.2. Test Procedure Used

ANSI C63.10 - 2013 Section 11.10.5

7.4.3. Test Setting

1. Measure the duty cycle (x) of the transmitter output signal.
2. Set instrument center frequency to DTS channel center frequency.
3. Set span to at least 1.5 times the OBW.
4. RBW = 10 kHz.
5. VBW = 30 kHz.
6. Detector = RMS.
7. Ensure that the number of measurement points in the sweep $\geq 2 \times \text{span}/\text{RBW}$.
8. Sweep time = auto couple.
9. Don't use sweep triggering. Allow sweep to "free run".
10. Employ trace averaging (RMS) mode over a minimum of 100 traces.
11. Use the peak marker function to determine the maximum amplitude level.
12. Add $10 \log(1/x)$, where x is the duty cycle measured in step (a), to the measured PSD to compute the average PSD during the actual transmission time.

7.4.4. Test Setup

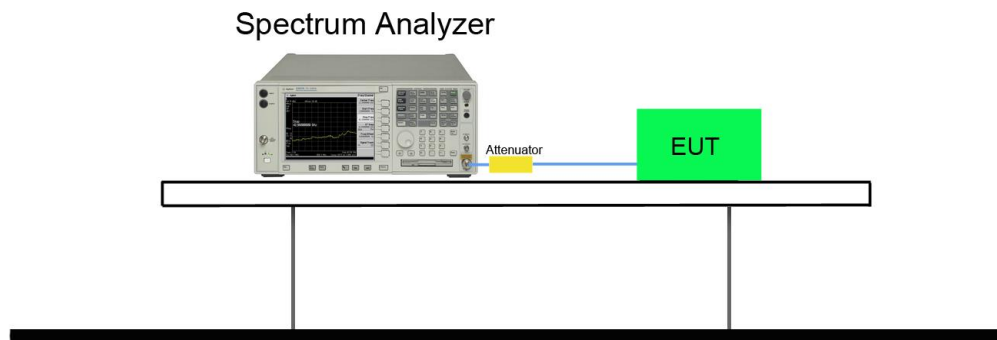

7.4.5. Test Result

| | | | |
|---------------|--|-------------------|-----------|
| Product | BE11000 Ceiling Mount Wi-Fi 7 Access Point | Temperature | 25°C |
| Test Engineer | Xuan Yu | Relative Humidity | 54% |
| Test Site | SR6 | Test Date | 2024/6/25 |

| Test Mode | Channel No. | Frequency (MHz) | PSD (dBm/10kHz) | Duty Cycle (%) | Total PSD (dBm/10kHz) | Limit (dBm/3kHz) | Result |
|-----------------|-------------|-----------------|-----------------|----------------|-----------------------|------------------|--------|
| LE 1Mbps | 00 | 2402 | 0.629 | 19.49% | 7.731 | ≤ 8 | Pass |
| | 19 | 2440 | 0.724 | 19.49% | 7.826 | ≤ 8 | Pass |
| | 39 | 2480 | 0.450 | 19.49% | 7.552 | ≤ 8 | Pass |
| LE Coded S=2 | 00 | 2402 | 3.531 | 40.38% | 7.469 | ≤ 8 | Pass |
| | 19 | 2440 | 3.481 | 40.38% | 7.419 | ≤ 8 | Pass |
| | 39 | 2480 | 3.734 | 40.38% | 7.672 | ≤ 8 | Pass |
| LE Coded S=8 | 00 | 2402 | 5.436 | 61.37% | 7.556 | ≤ 8 | Pass |
| | 19 | 2440 | 5.704 | 61.37% | 7.824 | ≤ 8 | Pass |
| | 39 | 2480 | 5.734 | 61.37% | 7.854 | ≤ 8 | Pass |

Note: Total Average PSD= Average PSD + 10*log (1/Duty Cycle).

LE 1Mbps

LE CH00 (2402MHz)



LE CH19 (2440MHz)



LE CH39 (2480MHz)



LE Coded S=2

LE CH00 (2402MHz)



LE CH19 (2440MHz)



LE CH39 (2480MHz)



LE Coded S=8

LE CH00 (2402MHz)



LE CH19 (2440MHz)



LE CH39 (2480MHz)



7.5. Out-of-Band Spurious Emissions Emissions Measurement

7.5.1. Test Limit

In any 100 kHz bandwidth outside the frequency band in which the spread spectrum or digitally modulated intentional radiator is operating, the radio frequency power that is produced by the intentional radiator shall be at least 30 dB below that in the 100 kHz bandwidth within the band that contains the highest level of the desired power, based on RF conducted measurement, provided the transmitter demonstrates compliance with the peak conducted power limits.

7.5.2. Test Procedure Used

ANSI C63.10 - 2013 Section 11.1 & 11.2

7.5.3. Test Setting

- (a) Set instrument center frequency to DTS channel center frequency
- (b) Set the span to ≥ 1.5 times the DTS bandwidth
- (c) Set the RBW = 100 kHz
- (d) Set the VBW $\geq 3 \times$ RBW
- (e) Detector = peak
- (f) Sweep time = auto couple
- (g) Trace mode = max hold
- (h) Allow trace to fully stabilize

7.5.4. Test Setup

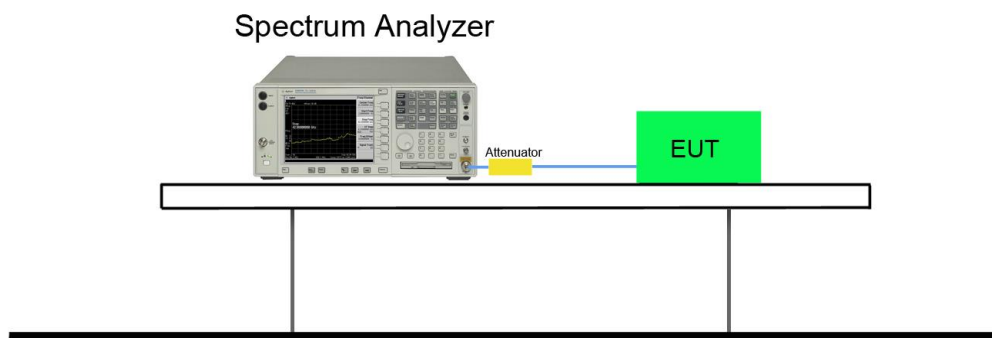

7.5.5. Test Result

| | | | |
|---------------|--|-------------------|-----------|
| Product | BE11000 Ceiling Mount Wi-Fi 7 Access Point | Temperature | 25°C |
| Test Engineer | Xuan Yu | Relative Humidity | 54% |
| Test Site | SR6 | Test Date | 2024/6/25 |

| Test Mode | Channel No. | Frequency (MHz) | Limit | Result |
|-----------------|-------------|-----------------|-------|--------|
| LE 1Mbps | 00 | 2402 | 30dBc | Pass |
| | 19 | 2440 | 30dBc | Pass |
| | 39 | 2480 | 30dBc | Pass |
| LE Coded S=2 | 00 | 2402 | 30dBc | Pass |
| | 19 | 2440 | 30dBc | Pass |
| | 39 | 2480 | 30dBc | Pass |
| LE Coded S=8 | 00 | 2402 | 30dBc | Pass |
| | 19 | 2440 | 30dBc | Pass |
| | 39 | 2480 | 30dBc | Pass |

LE 1Mbps

CH00 (2402MHz) LE(1Mbps)

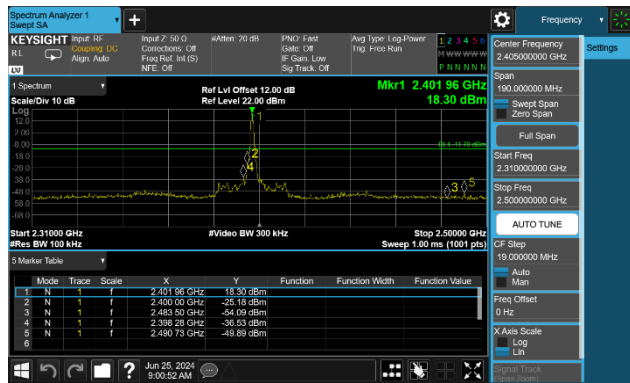

CH00 (2402MHz) LE(1Mbps)

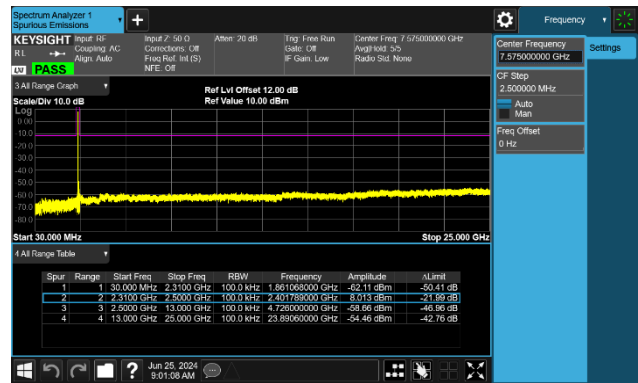

CH19 (2440MHz) LE(1Mbps)

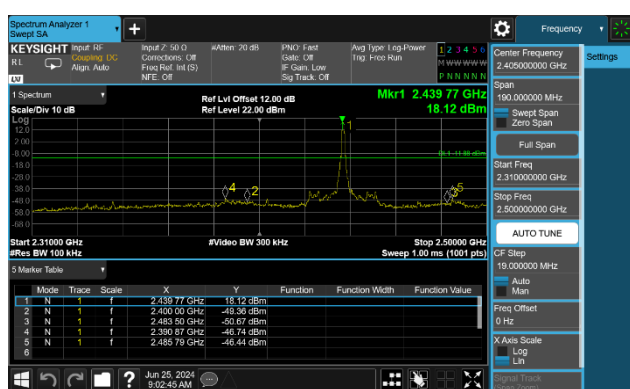

CH19 (2440MHz) LE(1Mbps)

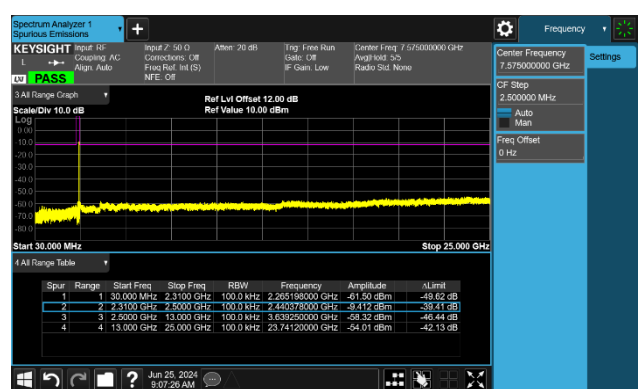

CH39 (2480MHz) LE(1Mbps)

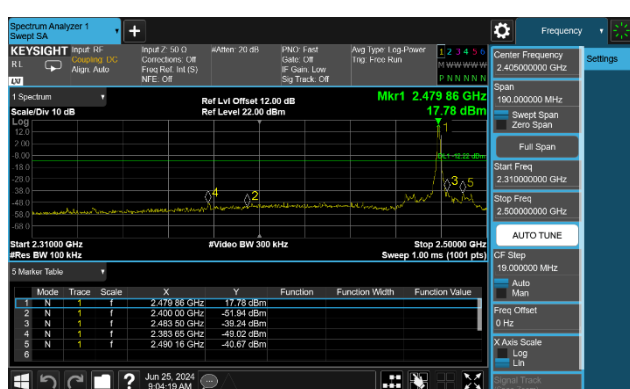

CH39 (2480MHz) LE(1Mbps)

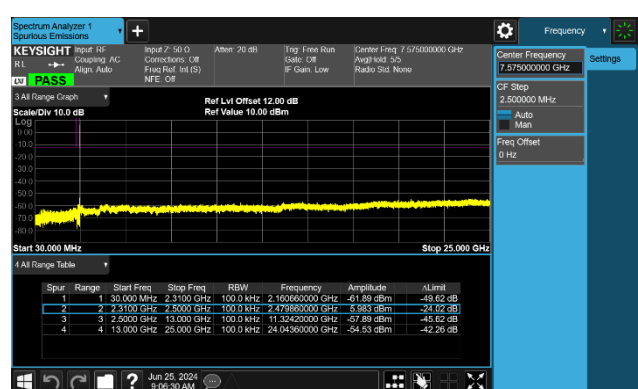

LE Coded S=2

CH00 (2402MHz) LE(1Mbps)

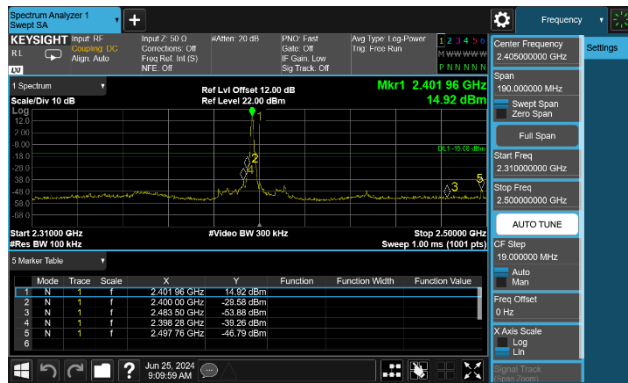

CH00 (2402MHz) LE(1Mbps)

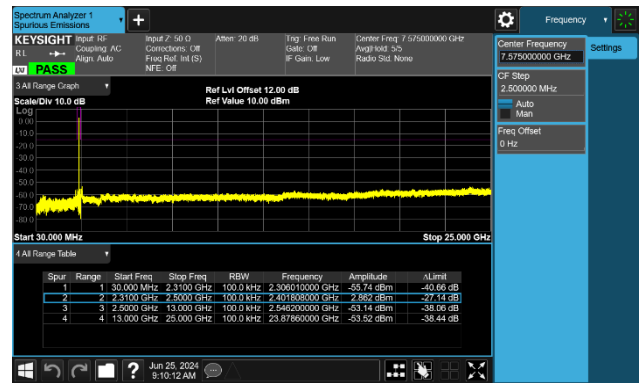

CH19 (2440MHz) LE(1Mbps)

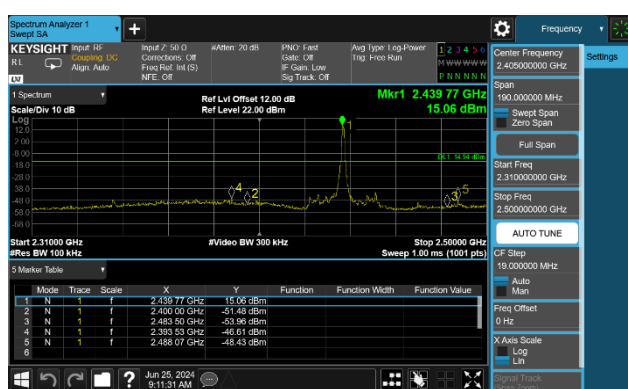

CH19 (2440MHz) LE(1Mbps)

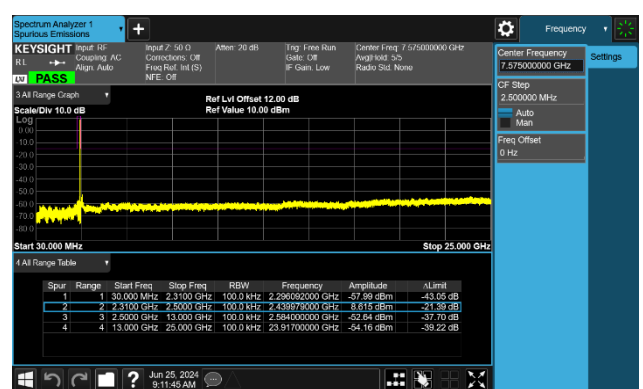

CH39 (2480MHz) LE(1Mbps)

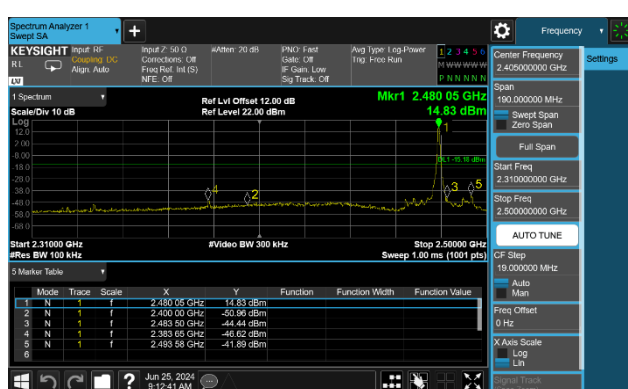

CH39 (2480MHz) LE(1Mbps)

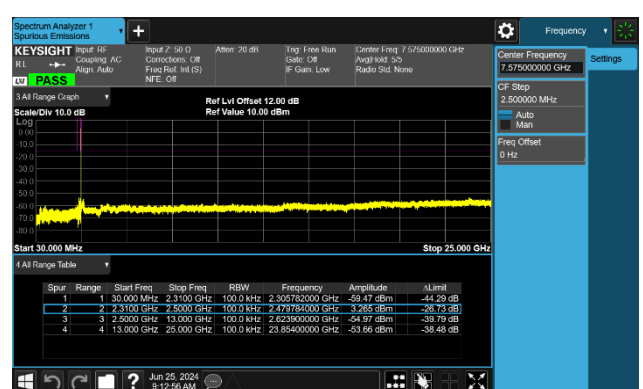

LE Coded S=8

CH00 (2402MHz) LE(1Mbps)

CH00 (2402MHz) LE(1Mbps)

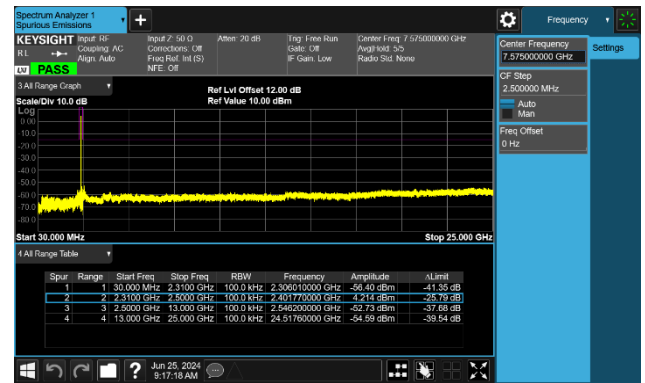
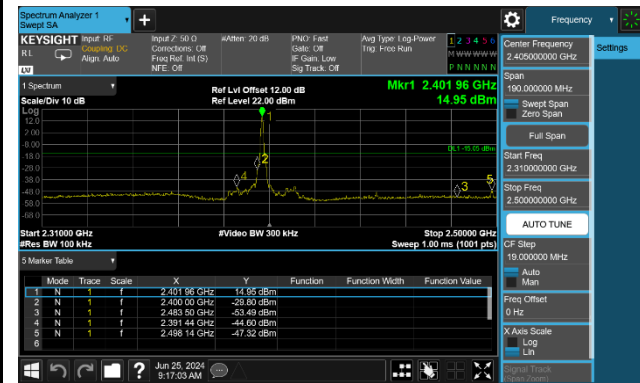

CH19 (2440MHz) LE(1Mbps)

CH19 (2440MHz) LE(1Mbps)

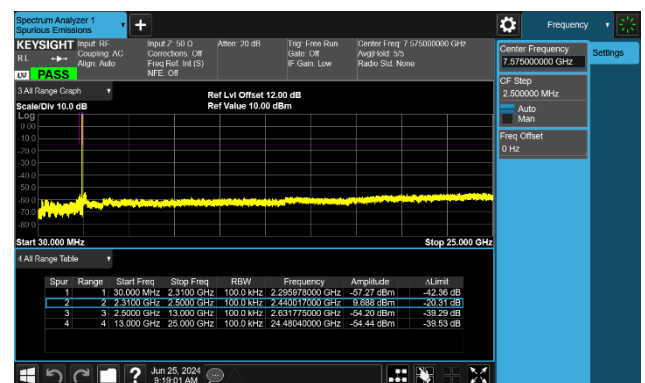
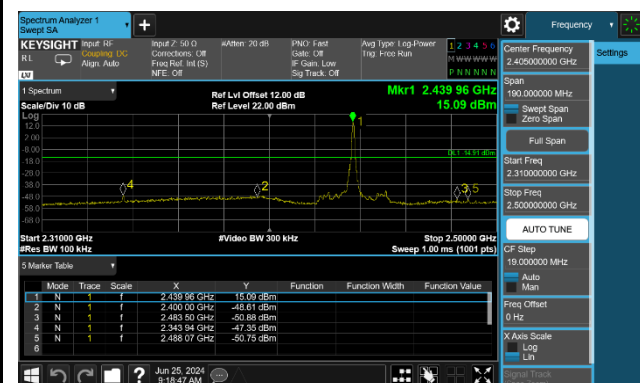

CH39 (2480MHz) LE(1Mbps)

CH39 (2480MHz) LE(1Mbps)

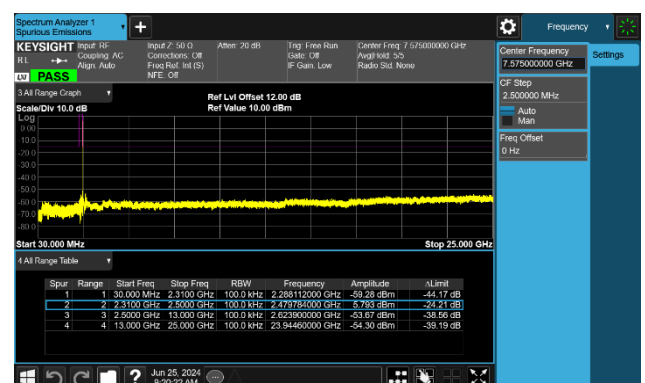
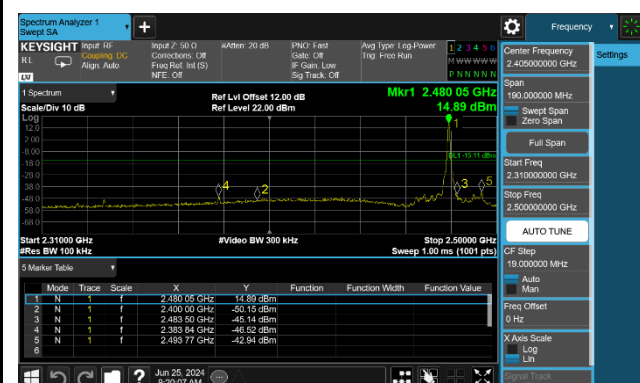

7.6. Radiated Spurious Emission Measurement

7.6.1. Test Limit

All out of band emissions appearing in a restricted band as specified in Section 15.205 of the Title 47 CFR must not exceed the limits shown in Table per Section 15.209.

| FCC Part 15 Subpart C Paragraph 15.209 | | |
|--|----------------------|----------------------------|
| Frequency [MHz] | Field Strength [V/m] | Measured Distance [Meters] |
| 0.009 - 0.490 | 2400/F (kHz) | 300 |
| 0.490 - 1.705 | 24000/F (kHz) | 30 |
| 1.705 - 30 | 30 | 30 |
| 30 - 88 | 100 | 3 |
| 88 - 216 | 150 | 3 |
| 216 - 960 | 200 | 3 |
| Above 960 | 500 | 3 |

7.6.2. Test Procedure Used

ANSI C63.10 - 2013 Section 6.3 (General Requirements)

ANSI C63.10 - 2013 Section 6.4 (Standard test method below 30MHz)

ANSI C63.10 - 2013 Section 6.5 (Standard test method above 30MHz to 1GHz)

ANSI C63.10 - 2013 Section 6.6 (Standard test method above 1GHz)

7.6.3. Test Setting

Peak Field Strength Measurements

1. Analyzer center frequency was set to the frequency of the radiated spurious emission of interest
2. RBW = as specified in Table 1
3. VBW = 3MHz
4. Detector = peak

5. Sweep time = auto couple
6. Trace mode = max hold
7. Trace was allowed to stabilize

Table 1 - RBW as a function of frequency

| Frequency | RBW |
|---------------|---------------|
| 9 ~ 150 kHz | 200 ~ 300 Hz |
| 0.15 ~ 30 MHz | 9 ~ 10 kHz |
| 30 ~ 1000 MHz | 100 ~ 120 kHz |
| > 1000 MHz | 1 MHz |

Average Field Strength Measurements

1. Analyzer center frequency was set to the frequency of the radiated spurious emission of interest
2. RBW = 1MHz
3. VBW \geq 1/T
4. De As an alternative, the instrument may be set to linear detector mode. Ensure that video filtering is applied in linear voltage domain (rather than in a log or dB domain). Some instruments require linear display mode in order to accomplish this. Others have a setting for Average-VBW Type, which can be set to "Voltage" regardless of the display mode
5. Detector = Peak
6. Sweep time = auto
7. Trace mode = max hold
8. Allow max hold to run for at least 50 times (1/duty cycle) traces

7.6.4. Test Setup

9kHz ~ 30MHz Test Setup:

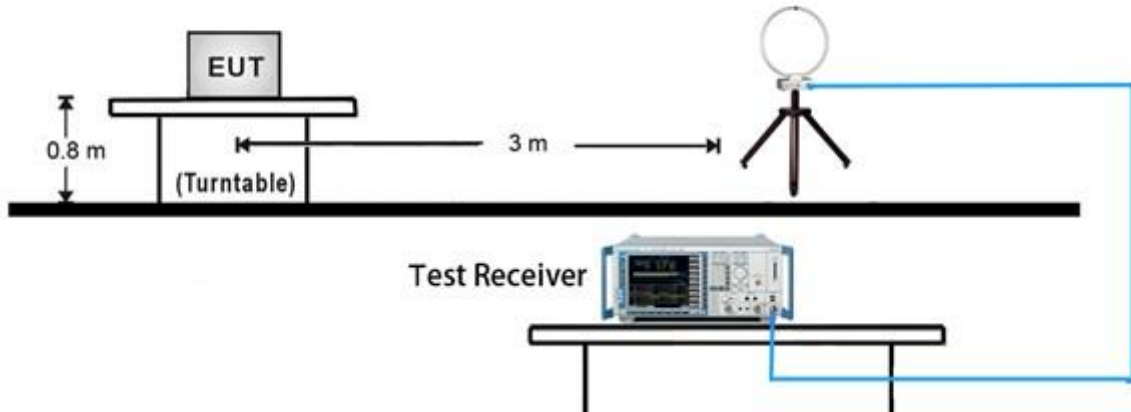

30MHz ~ 1GHz Test Setup:

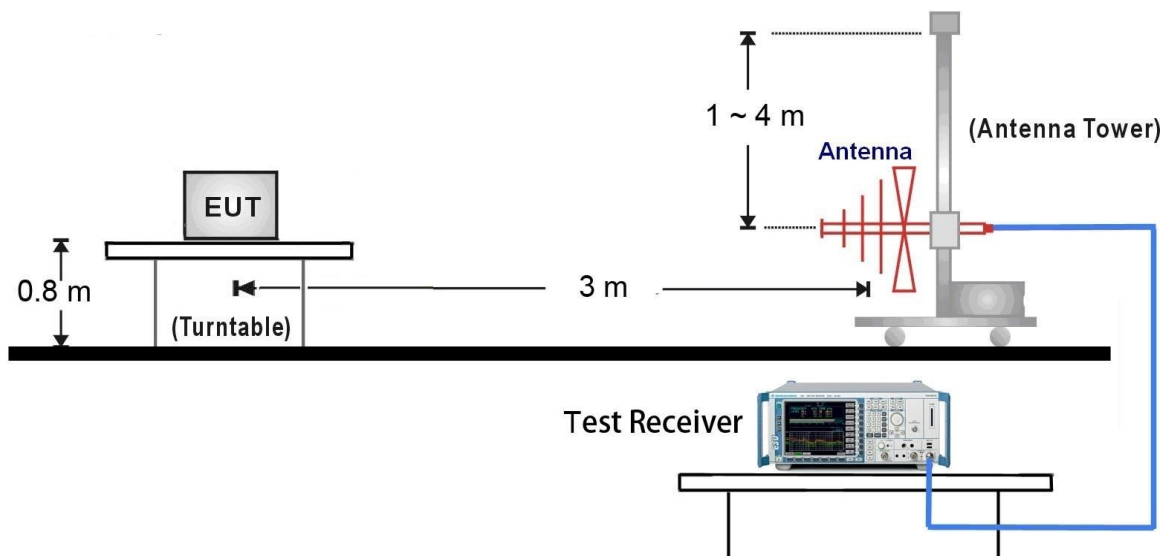

1GHz ~ 25GHz Test Setup:

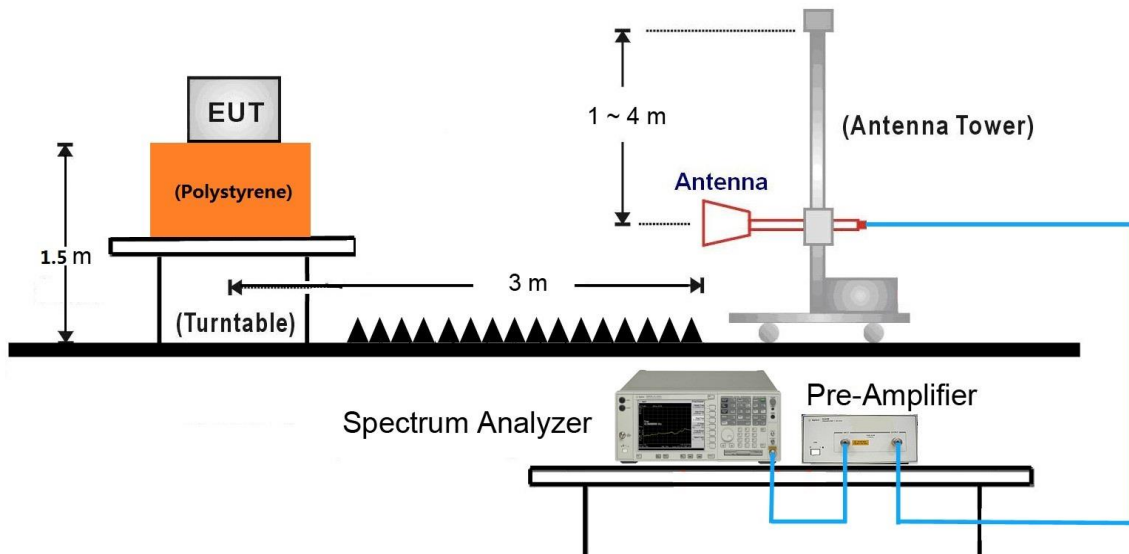

7.6.5. Test Result

| | | | |
|-----------|--|----------------------|--------------|
| EUT | BE11000 Ceiling Mount Wi-Fi 7 Access Point | Date of Test | 2024-05-28 |
| Factor | VULB 9162 | Temp. / Humidity | 22°C /61% |
| Polarity | Horizontal | Site / Test Engineer | AC2 / You |
| Test Mode | BLE_TX_1Mbps_CH 19 | Test Voltage | AC 120V/60Hz |

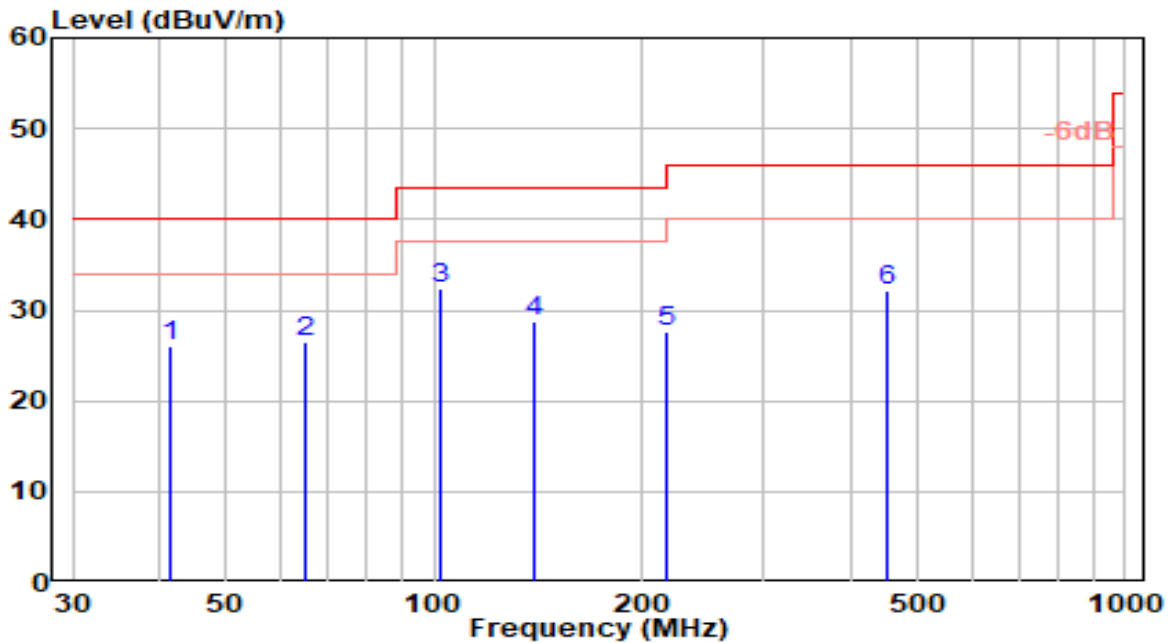

| No | Frequency (MHz) | Reading (dBuV) | C.F (dB/m) | Measurement (dBuV/m) | Margin (dB) | Limit (dBuV/m) | Height (cm) | Angle (deg) | Remark (QP/PK/AV) |
|----|-----------------|----------------|------------|----------------------|-------------|----------------|-------------|-------------|-------------------|
| 1 | 41.465 | 6.11 | 19.97 | 26.08 | -13.92 | 40.00 | 200 | 282 | QP |
| 2 | 65.024 | 9.18 | 17.41 | 26.59 | -13.41 | 40.00 | 200 | 251 | QP |
| 3 | * 102.454 | 14.00 | 18.33 | 32.33 | -11.17 | 43.50 | 200 | 326 | QP |
| 4 | 139.362 | 14.09 | 14.78 | 28.87 | -14.63 | 43.50 | 200 | 320 | QP |
| 5 | 217.174 | 9.49 | 18.16 | 27.65 | -18.35 | 46.00 | 100 | 305 | QP |
| 6 | 453.640 | 8.32 | 23.90 | 32.22 | -13.78 | 46.00 | 100 | 80 | QP |

Note:

1. " *", means this data is the worst emission level.
2. C.F (Correction Factor) = Antenna Factor (dB/m) + Cable Loss (dB).
3. Measurement (dBuV/m) = Reading(dBuV) + C.F (Correction Factor).
4. The emission levels of other frequencies are very lower than the limit and not show in test report.

| | | | |
|-----------|--|----------------------|--------------|
| EUT | BE11000 Ceiling Mount Wi-Fi 7 Access Point | Date of Test | 2024-05-28 |
| Factor | VULB 9162 | Temp. / Humidity | 22°C /61% |
| Polarity | Vertical | Site / Test Engineer | AC2 / You |
| Test Mode | BLE_TX_1Mbps_CH 19 | Test Voltage | AC 120V/60Hz |

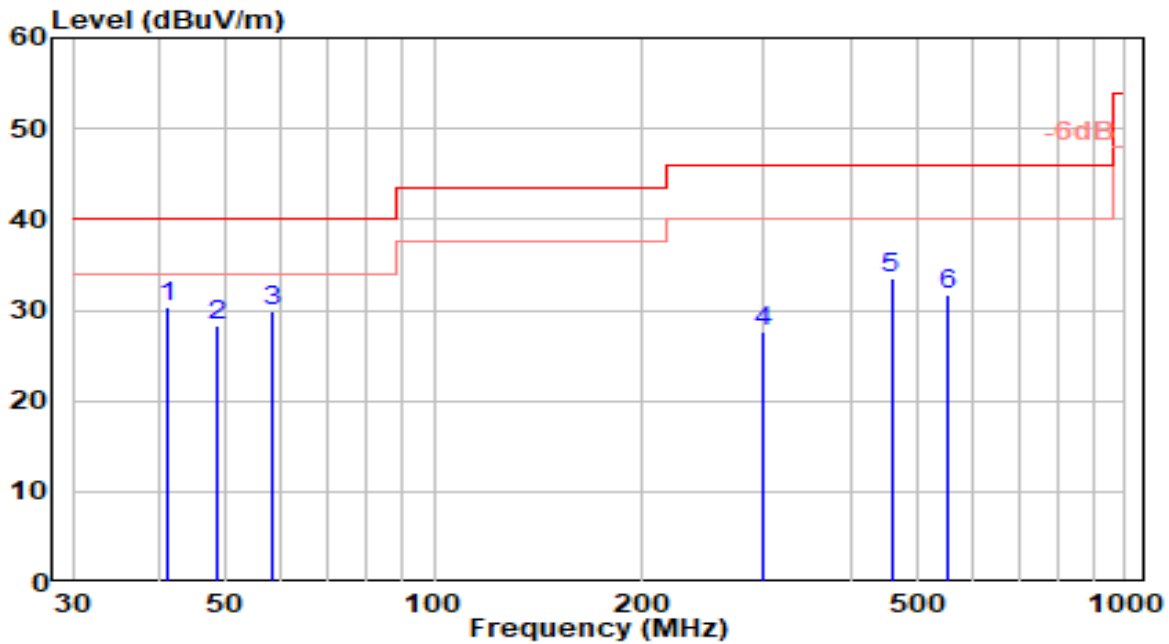

| No | Frequency (MHz) | Reading (dBuV) | C.F (dB/m) | Measurement (dBuV/m) | Margin (dB) | Limit (dBuV/m) | Height (cm) | Angle (deg) | Remark (QP/PK/AV) |
|----|-----------------|----------------|------------|----------------------|-------------|----------------|-------------|-------------|-------------------|
| 1 | * 41.184 | 10.33 | 19.93 | 30.26 | -9.74 | 40.00 | 100 | 327 | QP |
| 2 | 48.349 | 7.93 | 20.47 | 28.40 | -11.60 | 40.00 | 100 | 298 | QP |
| 3 | 58.113 | 10.51 | 19.47 | 29.98 | -10.02 | 40.00 | 100 | 303 | QP |
| 4 | 299.387 | 6.92 | 20.60 | 27.52 | -18.48 | 46.00 | 100 | 15 | QP |
| 5 | 458.657 | 9.42 | 24.02 | 33.44 | -12.56 | 46.00 | 100 | 22 | QP |
| 6 | 556.104 | 5.67 | 25.91 | 31.59 | -14.41 | 46.00 | 100 | 29 | QP |

Note:

- "*" means this data is the worst emission level.
- C.F (Correction Factor) = Antenna Factor (dB/m) + Cable Loss (dB).
- Measurement (dBuV/m) = Reading(dBuV) + C.F (Correction Factor).
- The emission levels of other frequencies are very lower than the limit and not show in test report.
- The amplitude of radiated emissions (frequency range from 9kHz to 30MHz) is that proximity to ambient noise, which also are attenuated more than 20dB below the permissible value. Therefore, the data is not presented in the report.

| | | | |
|-----------|--|----------------------|--------------|
| EUT | BE11000 Ceiling Mount Wi-Fi 7 Access Point | Date of Test | 2024-06-28 |
| Factor | DRH18-E | Temp. / Humidity | 24°C /60% |
| Polarity | Horizontal | Site / Test Engineer | AC2 / You |
| Test Mode | BLE_1Mbps_TX_CH 0 | Test Voltage | AC 120V/60Hz |

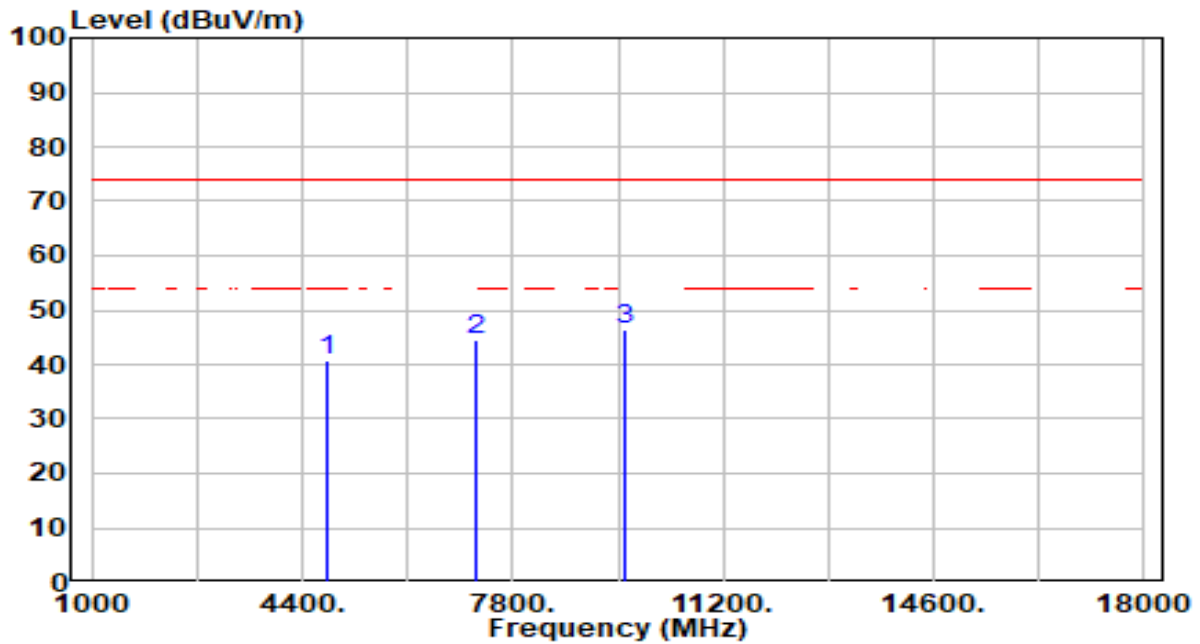

| No | Frequency (MHz) | Reading (dBuV) | C.F (dB/m) | Measurement (dBuV/m) | Margin (dB) | Limit (dBuV/m) | Height (cm) | Angle (deg) | Remark (QP/PK/AV) |
|----|-----------------|----------------|------------|----------------------|-------------|----------------|-------------|-------------|-------------------|
| 1 | 4804.000 | 40.65 | 0.18 | 40.83 | -33.17 | 74.00 | 100 | 48 | Peak |
| 2 | 7206.000 | 39.11 | 5.53 | 44.63 | -29.37 | 74.00 | 300 | 0 | Peak |
| 3 | * 9608.000 | 41.29 | 5.29 | 46.58 | -27.42 | 74.00 | 300 | 156 | Peak |

Note:

1. " *" , means this data is the worst emission level.
2. C.F (Correction Factor) = Antenna Factor (dB/m) + Cable Loss (dB) – Preamplifier(dB).
3. Measurement (dBuV/m) = Reading(dBuV) + C.F (Correction Factor).
4. The emission levels of other frequencies are very lower than the limit and not show in test report.

| | | | |
|-----------|--|----------------------|--------------|
| EUT | BE11000 Ceiling Mount Wi-Fi 7 Access Point | Date of Test | 2024-06-28 |
| Factor | DRH18-E | Temp. / Humidity | 24°C /60% |
| Polarity | Vertical | Site / Test Engineer | AC2 / You |
| Test Mode | BLE_1Mbps_TX_CH 0 | Test Voltage | AC 120V/60Hz |

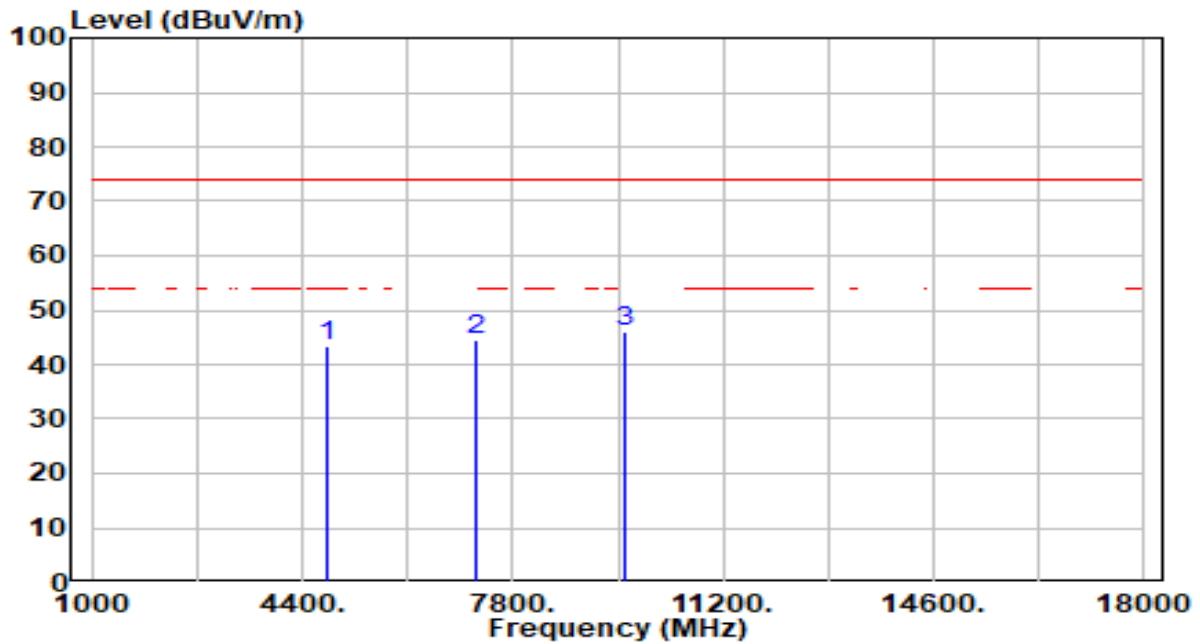

| No | Frequency (MHz) | Reading (dBuV) | C.F (dB/m) | Measurement (dBuV/m) | Margin (dB) | Limit (dBuV/m) | Height (cm) | Angle (deg) | Remark (QP/PK/AV) |
|----|-----------------|----------------|------------|----------------------|-------------|----------------|-------------|-------------|-------------------|
| 1 | 4804.000 | 43.21 | 0.18 | 43.39 | -30.61 | 74.00 | 200 | 209 | Peak |
| 2 | 7206.000 | 39.13 | 5.53 | 44.66 | -29.34 | 74.00 | 300 | 33 | Peak |
| 3 | * 9608.000 | 40.72 | 5.29 | 46.00 | -28.00 | 74.00 | 300 | 291 | Peak |

Note:

1. " *", means this data is the worst emission level.
2. C.F (Correction Factor) = Antenna Factor (dB/m) + Cable Loss (dB) – Preamplifier(dB).
3. Measurement (dBuV/m) = Reading(dBuV) + C.F (Correction Factor).
4. The emission levels of other frequencies are very lower than the limit and not show in test report.

| | | | |
|-----------|--|----------------------|--------------|
| EUT | BE11000 Ceiling Mount Wi-Fi 7 Access Point | Date of Test | 2024-06-28 |
| Factor | DRH18-E | Temp. / Humidity | 24°C /60% |
| Polarity | Horizontal | Site / Test Engineer | AC2 / You |
| Test Mode | BLE_1Mbps_TX_CH 19 | Test Voltage | AC 120V/60Hz |

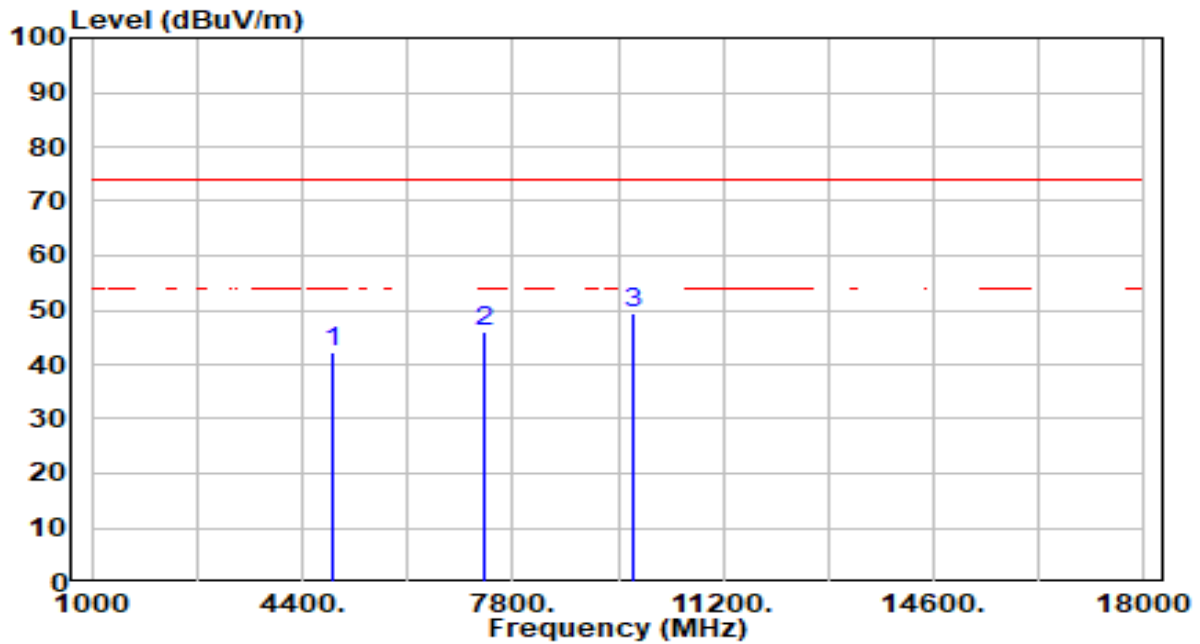

| No | Frequency (MHz) | Reading (dBuV) | C.F (dB/m) | Measurement (dBuV/m) | Margin (dB) | Limit (dBuV/m) | Height (cm) | Angle (deg) | Remark (QP/PK/AV) |
|----|-----------------|----------------|------------|----------------------|-------------|----------------|-------------|-------------|-------------------|
| 1 | 4880.000 | 41.94 | 0.38 | 42.32 | -31.68 | 74.00 | 300 | 151 | Peak |
| 2 | 7320.000 | 40.54 | 5.60 | 46.14 | -27.86 | 74.00 | 200 | 178 | Peak |
| 3 | * 9760.000 | 44.22 | 5.35 | 49.57 | -24.43 | 74.00 | 300 | 274 | Peak |

Note:

1. " *", means this data is the worst emission level.
2. C.F (Correction Factor) = Antenna Factor (dB/m) + Cable Loss (dB) – Preamplifier(dB).
3. Measurement (dBuV/m) = Reading(dBuV) + C.F (Correction Factor).
4. The emission levels of other frequencies are very lower than the limit and not show in test report.

| | | | |
|-----------|--|----------------------|--------------|
| EUT | BE11000 Ceiling Mount Wi-Fi 7 Access Point | Date of Test | 2024-06-28 |
| Factor | DRH18-E | Temp. / Humidity | 24°C /60% |
| Polarity | Vertical | Site / Test Engineer | AC2 / You |
| Test Mode | BLE_1Mbps_TX_CH 19 | Test Voltage | AC 120V/60Hz |

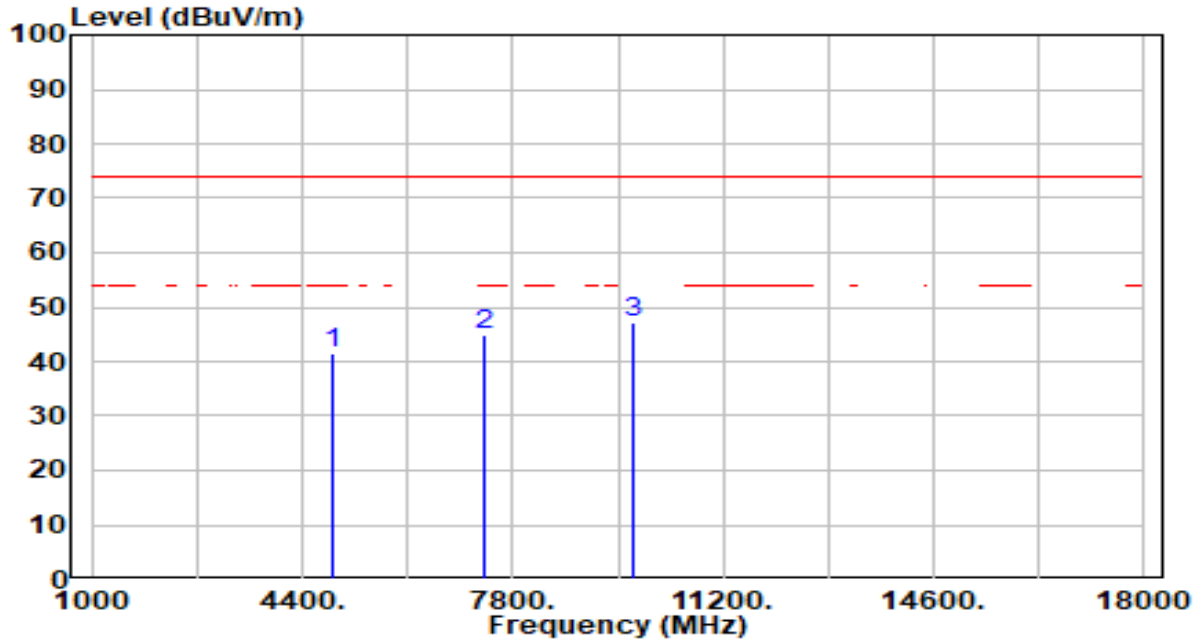

| No | Frequency (MHz) | Reading (dBuV) | C.F (dB/m) | Measurement (dBuV/m) | Margin (dB) | Limit (dBuV/m) | Height (cm) | Angle (deg) | Remark (QP/PK/AV) |
|----|-----------------|----------------|------------|----------------------|-------------|----------------|-------------|-------------|-------------------|
| 1 | 4880.000 | 41.08 | 0.38 | 41.46 | -32.54 | 74.00 | 100 | 188 | Peak |
| 2 | 7320.000 | 39.24 | 5.60 | 44.83 | -29.17 | 74.00 | 293 | 0 | Peak |
| 3 | * 9760.000 | 41.65 | 5.35 | 46.99 | -27.01 | 74.00 | 200 | 151 | Peak |

Note:

1. " *", means this data is the worst emission level.
2. C.F (Correction Factor) = Antenna Factor (dB/m) + Cable Loss (dB) – Preamplifier(dB).
3. Measurement (dBuV/m) = Reading(dBuV) + C.F (Correction Factor).
4. The emission levels of other frequencies are very lower than the limit and not show in test report.

| | | | |
|-----------|--|----------------------|--------------|
| EUT | BE11000 Ceiling Mount Wi-Fi 7 Access Point | Date of Test | 2024-06-28 |
| Factor | DRH18-E | Temp. / Humidity | 24°C /60% |
| Polarity | Horizontal | Site / Test Engineer | AC2 / You |
| Test Mode | BLE_1Mbps_TX_CH 39 | Test Voltage | AC 120V/60Hz |

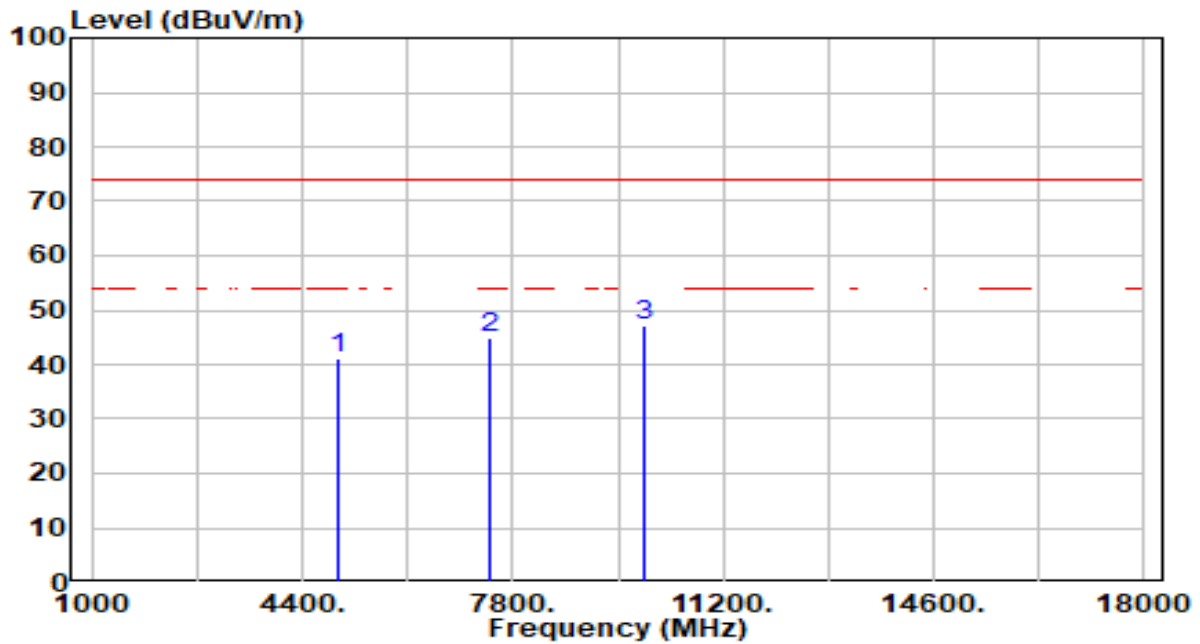

| No | Frequency (MHz) | Reading (dBuV) | C.F (dB/m) | Measurement (dBuV/m) | Margin (dB) | Limit (dBuV/m) | Height (cm) | Angle (deg) | Remark (QP/PK/AV) |
|----|-----------------|----------------|------------|----------------------|-------------|----------------|-------------|-------------|-------------------|
| 1 | 4960.000 | 40.71 | 0.59 | 41.30 | -32.70 | 74.00 | 200 | 333 | Peak |
| 2 | 7440.000 | 39.10 | 5.63 | 44.73 | -29.27 | 74.00 | 300 | 114 | Peak |
| 3 | * 9920.000 | 41.71 | 5.42 | 47.13 | -26.87 | 74.00 | 100 | 34 | Peak |

Note:

1. " *", means this data is the worst emission level.
2. C.F (Correction Factor) = Antenna Factor (dB/m) + Cable Loss (dB) – Preamplifier(dB).
3. Measurement (dBuV/m) = Reading(dBuV) + C.F (Correction Factor).
4. The emission levels of other frequencies are very lower than the limit and not show in test report.

| | | | |
|-----------|--|----------------------|--------------|
| EUT | BE11000 Ceiling Mount Wi-Fi 7 Access Point | Date of Test | 2024-06-28 |
| Factor | DRH18-E | Temp. / Humidity | 24°C /60% |
| Polarity | Vertical | Site / Test Engineer | AC2 / You |
| Test Mode | BLE_1Mbps_TX_CH 39 | Test Voltage | AC 120V/60Hz |

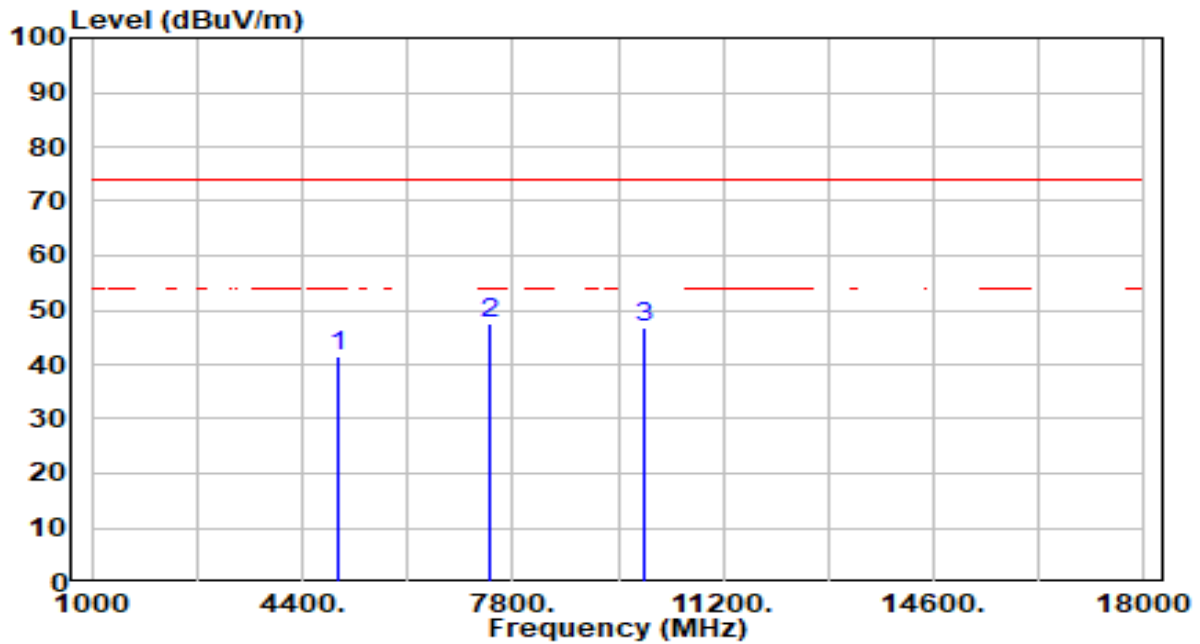

| No | Frequency (MHz) | Reading (dBuV) | C.F (dB/m) | Measurement (dBuV/m) | Margin (dB) | Limit (dBuV/m) | Height (cm) | Angle (deg) | Remark (QP/PK/AV) |
|----|-----------------|----------------|------------|----------------------|-------------|----------------|-------------|-------------|-------------------|
| 1 | 4960.000 | 40.89 | 0.59 | 41.48 | -32.52 | 74.00 | 300 | 202 | Peak |
| 2 | * 7440.000 | 41.95 | 5.63 | 47.57 | -26.43 | 74.00 | 100 | 208 | Peak |
| 3 | 9920.000 | 41.24 | 5.42 | 46.66 | -27.34 | 74.00 | 300 | 204 | Peak |

Note:

1. " *", means this data is the worst emission level.
2. C.F (Correction Factor) = Antenna Factor (dB/m) + Cable Loss (dB) – Preamplifier(dB).
3. Measurement (dBuV/m) = Reading(dBuV) + C.F (Correction Factor).
4. The emission levels of other frequencies are very lower than the limit and not show in test report.

| | | | |
|-----------|--|----------------------|--------------|
| EUT | BE11000 Ceiling Mount Wi-Fi 7 Access Point | Date of Test | 2024-06-28 |
| Factor | DRH18-E | Temp. / Humidity | 24°C /60% |
| Polarity | Horizontal | Site / Test Engineer | AC2 / You |
| Test Mode | BLE_S2_TX_CH 0 | Test Voltage | AC 120V/60Hz |

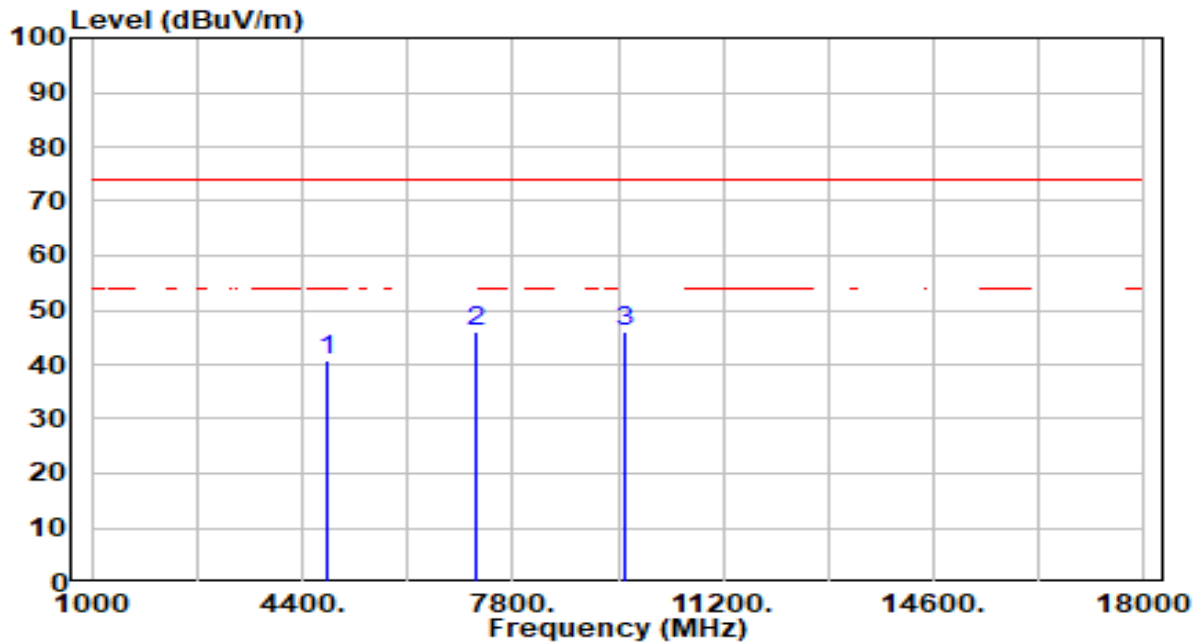

| No | Frequency (MHz) | Reading (dBuV) | C.F (dB/m) | Measurement (dBuV/m) | Margin (dB) | Limit (dBuV/m) | Height (cm) | Angle (deg) | Remark (QP/PK/AV) |
|----|-----------------|----------------|------------|----------------------|-------------|----------------|-------------|-------------|-------------------|
| 1 | 4804.000 | 40.41 | 0.18 | 40.59 | -33.41 | 74.00 | 200 | 221 | Peak |
| 2 | * 7206.000 | 40.56 | 5.53 | 46.08 | -27.92 | 74.00 | 300 | 166 | Peak |
| 3 | 9608.000 | 40.60 | 5.29 | 45.88 | -28.12 | 74.00 | 100 | 0 | Peak |

Note:

1. " *", means this data is the worst emission level.
2. C.F (Correction Factor) = Antenna Factor (dB/m) + Cable Loss (dB) – Preamplifier(dB).
3. Measurement (dBuV/m) = Reading(dBuV) + C.F (Correction Factor).
4. The emission levels of other frequencies are very lower than the limit and not show in test report.

| | | | |
|-----------|--|----------------------|--------------|
| EUT | BE11000 Ceiling Mount Wi-Fi 7 Access Point | Date of Test | 2024-06-28 |
| Factor | DRH18-E | Temp. / Humidity | 24°C /60% |
| Polarity | Vertical | Site / Test Engineer | AC2 / You |
| Test Mode | BLE_S2_TX_CH 0 | Test Voltage | AC 120V/60Hz |

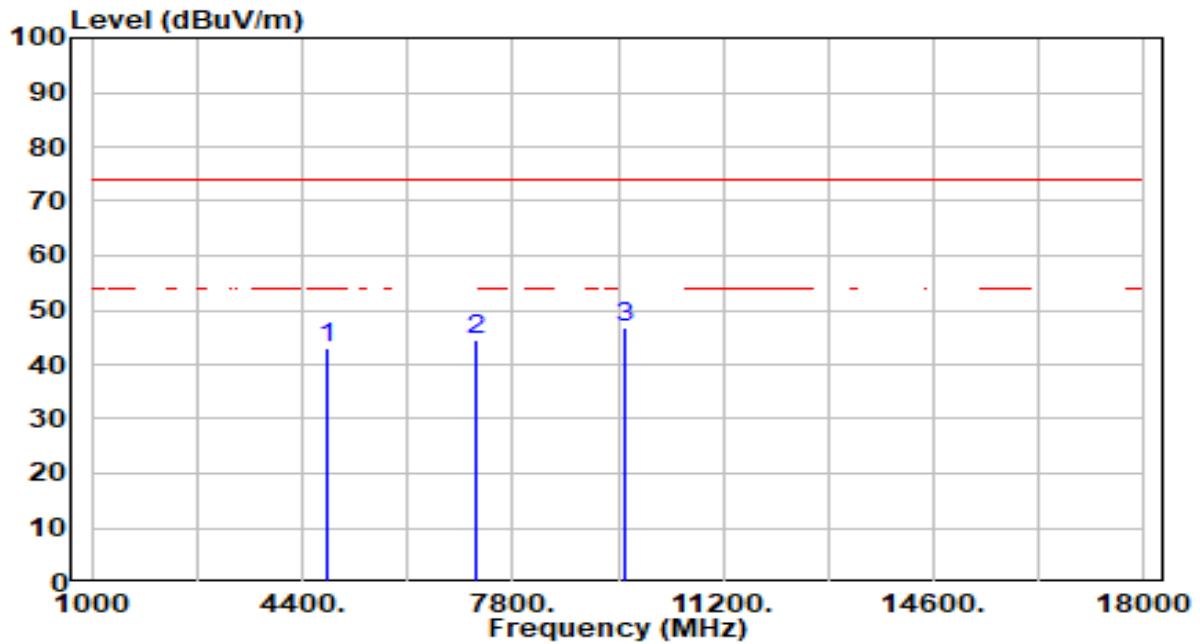

| No | Frequency (MHz) | Reading (dBuV) | C.F (dB/m) | Measurement (dBuV/m) | Margin (dB) | Limit (dBuV/m) | Height (cm) | Angle (deg) | Remark (QP/PK/AV) |
|----|-----------------|----------------|------------|----------------------|-------------|----------------|-------------|-------------|-------------------|
| 1 | 4804.000 | 43.02 | 0.18 | 43.20 | -30.80 | 74.00 | 200 | 185 | Peak |
| 2 | 7206.000 | 38.93 | 5.53 | 44.46 | -29.54 | 74.00 | 109 | 360 | Peak |
| 3 | * 9608.000 | 41.57 | 5.29 | 46.85 | -27.15 | 74.00 | 100 | 166 | Peak |

Note:

1. " *", means this data is the worst emission level.
2. C.F (Correction Factor) = Antenna Factor (dB/m) + Cable Loss (dB) – Preamplifier(dB).
3. Measurement (dBuV/m) = Reading(dBuV) + C.F (Correction Factor).
4. The emission levels of other frequencies are very lower than the limit and not show in test report.

| | | | |
|-----------|--|----------------------|--------------|
| EUT | BE11000 Ceiling Mount Wi-Fi 7 Access Point | Date of Test | 2024-06-28 |
| Factor | DRH18-E | Temp. / Humidity | 24°C /60% |
| Polarity | Horizontal | Site / Test Engineer | AC2 / You |
| Test Mode | BLE_S2_TX_CH 19 | Test Voltage | AC 120V/60Hz |

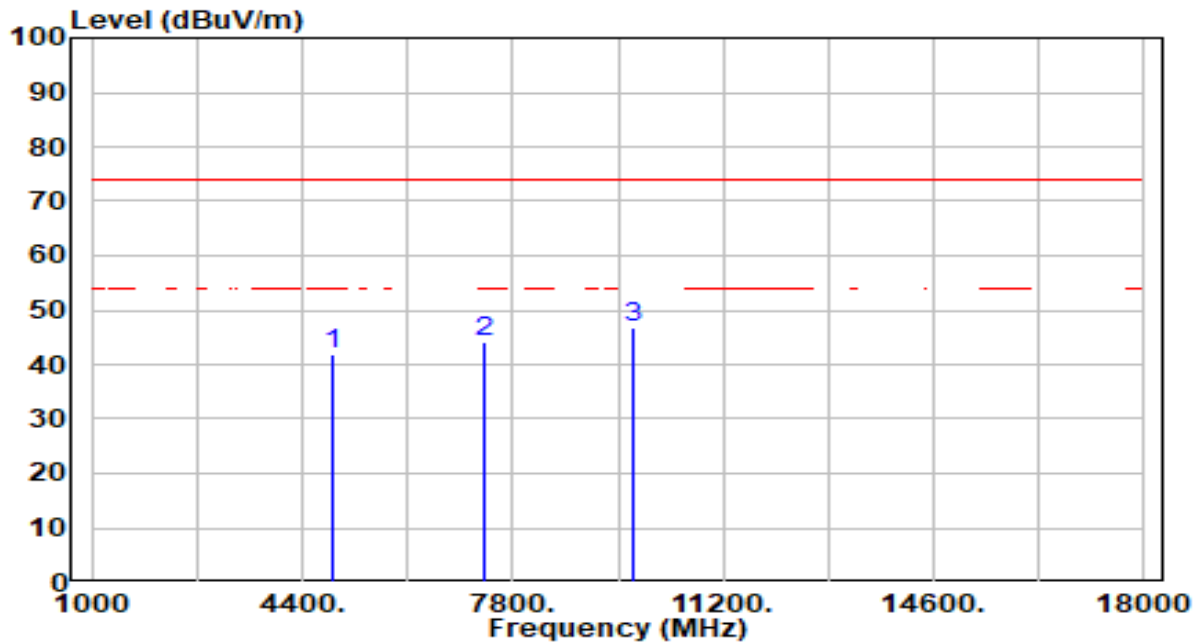

| No | Frequency (MHz) | Reading (dBuV) | C.F (dB/m) | Measurement (dBuV/m) | Margin (dB) | Limit (dBuV/m) | Height (cm) | Angle (deg) | Remark (QP/PK/AV) |
|----|-----------------|----------------|------------|----------------------|-------------|----------------|-------------|-------------|-------------------|
| 1 | 4880.000 | 41.33 | 0.38 | 41.70 | -32.30 | 74.00 | 100 | 187 | Peak |
| 2 | 7320.000 | 38.74 | 5.60 | 44.33 | -29.67 | 74.00 | 300 | 74 | Peak |
| 3 | * 9760.000 | 41.63 | 5.35 | 46.98 | -27.02 | 74.00 | 300 | 245 | Peak |

Note:

1. " *", means this data is the worst emission level.
2. C.F (Correction Factor) = Antenna Factor (dB/m) + Cable Loss (dB) – Preamplifier(dB).
3. Measurement (dBuV/m) = Reading(dBuV) + C.F (Correction Factor).
4. The emission levels of other frequencies are very lower than the limit and not show in test report.

| | | | |
|-----------|--|----------------------|--------------|
| EUT | BE11000 Ceiling Mount Wi-Fi 7 Access Point | Date of Test | 2024-06-28 |
| Factor | DRH18-E | Temp. / Humidity | 24°C /60% |
| Polarity | Vertical | Site / Test Engineer | AC2 / You |
| Test Mode | BLE_S2_TX_CH 19 | Test Voltage | AC 120V/60Hz |

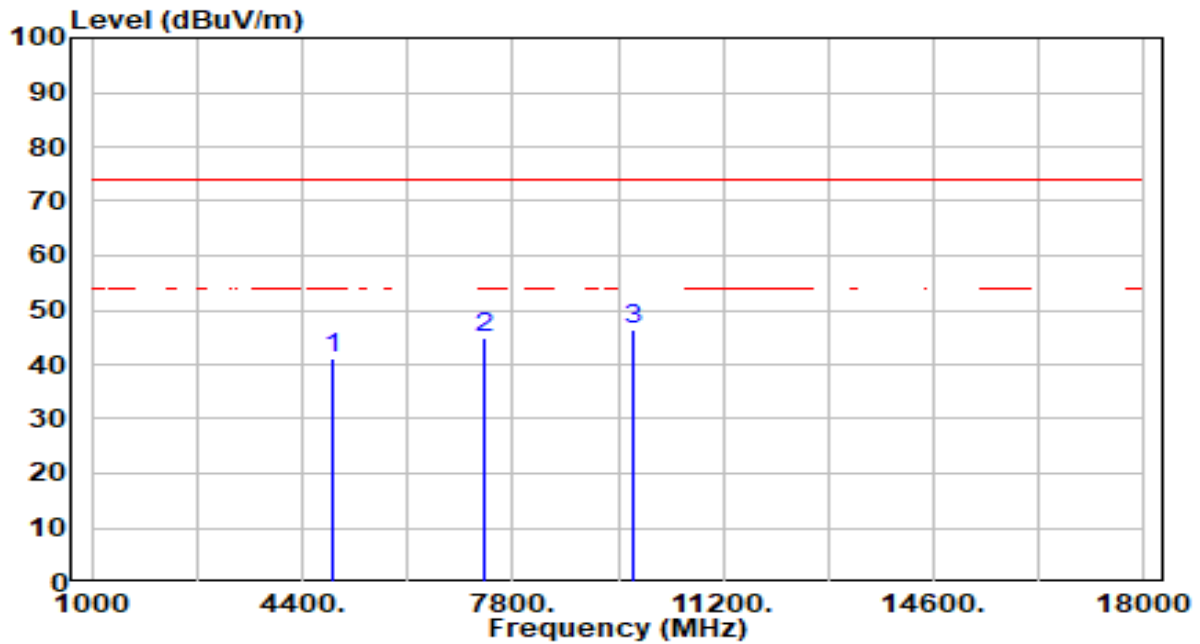

| No | Frequency (MHz) | Reading (dBuV) | C.F (dB/m) | Measurement (dBuV/m) | Margin (dB) | Limit (dBuV/m) | Height (cm) | Angle (deg) | Remark (QP/PK/AV) |
|----|-----------------|----------------|------------|----------------------|-------------|----------------|-------------|-------------|-------------------|
| 1 | 4880.000 | 40.62 | 0.38 | 40.99 | -33.01 | 74.00 | 300 | 185 | Peak |
| 2 | 7320.000 | 39.22 | 5.60 | 44.81 | -29.19 | 74.00 | 100 | 170 | Peak |
| 3 | * 9760.000 | 40.97 | 5.35 | 46.32 | -27.68 | 74.00 | 100 | 119 | Peak |

Note:

1. " *", means this data is the worst emission level.
2. C.F (Correction Factor) = Antenna Factor (dB/m) + Cable Loss (dB) – Preamplifier(dB).
3. Measurement (dBuV/m) = Reading(dBuV) + C.F (Correction Factor).
4. The emission levels of other frequencies are very lower than the limit and not show in test report.

| | | | |
|-----------|--|----------------------|--------------|
| EUT | BE11000 Ceiling Mount Wi-Fi 7 Access Point | Date of Test | 2024-06-28 |
| Factor | DRH18-E | Temp. / Humidity | 24°C /60% |
| Polarity | Horizontal | Site / Test Engineer | AC2 / You |
| Test Mode | BLE_S2_TX_CH 39 | Test Voltage | AC 120V/60Hz |

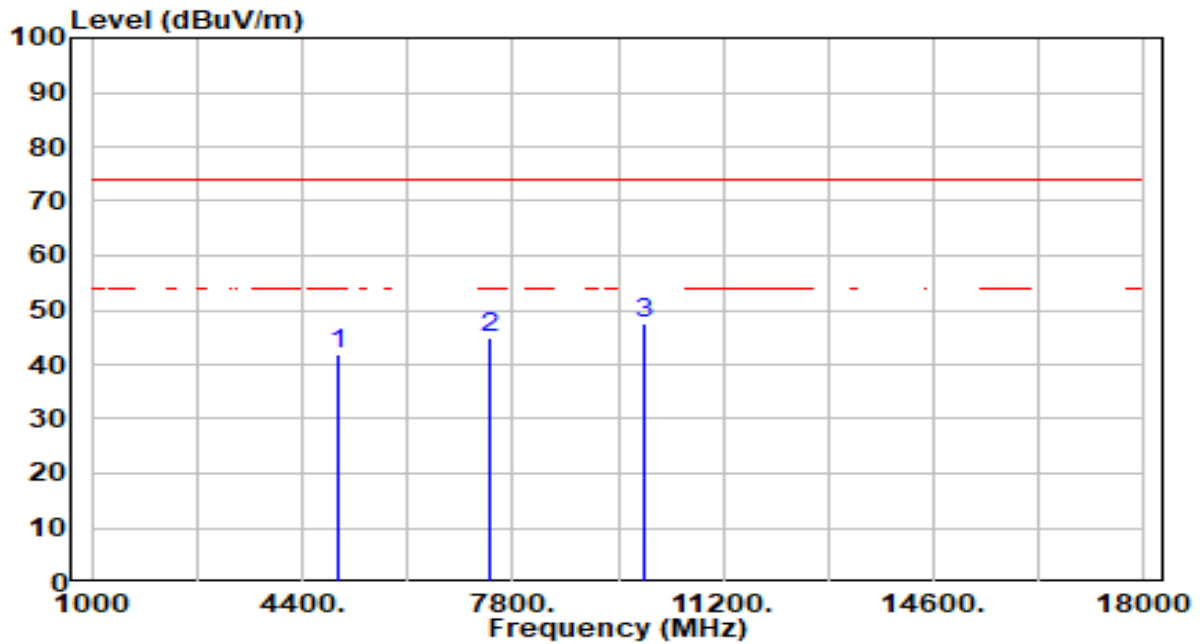

| No | Frequency (MHz) | Reading (dBuV) | C.F (dB/m) | Measurement (dBuV/m) | Margin (dB) | Limit (dBuV/m) | Height (cm) | Angle (deg) | Remark (QP/PK/AV) |
|----|-----------------|----------------|------------|----------------------|-------------|----------------|-------------|-------------|-------------------|
| 1 | 4960.000 | 41.41 | 0.59 | 42.00 | -32.00 | 74.00 | 298 | 360 | Peak |
| 2 | 7440.000 | 39.38 | 5.63 | 45.01 | -28.99 | 74.00 | 100 | 359 | Peak |
| 3 | * 9920.000 | 42.27 | 5.42 | 47.69 | -26.31 | 74.00 | 100 | 255 | Peak |

Note:

1. " *", means this data is the worst emission level.
2. C.F (Correction Factor) = Antenna Factor (dB/m) + Cable Loss (dB) – Preamplifier(dB).
3. Measurement (dBuV/m) = Reading(dBuV) + C.F (Correction Factor).
4. The emission levels of other frequencies are very lower than the limit and not show in test report.

| | | | |
|-----------|--|----------------------|--------------|
| EUT | BE11000 Ceiling Mount Wi-Fi 7 Access Point | Date of Test | 2024-06-28 |
| Factor | DRH18-E | Temp. / Humidity | 24°C /60% |
| Polarity | Vertical | Site / Test Engineer | AC2 / You |
| Test Mode | BLE_S2_TX_CH 39 | Test Voltage | AC 120V/60Hz |

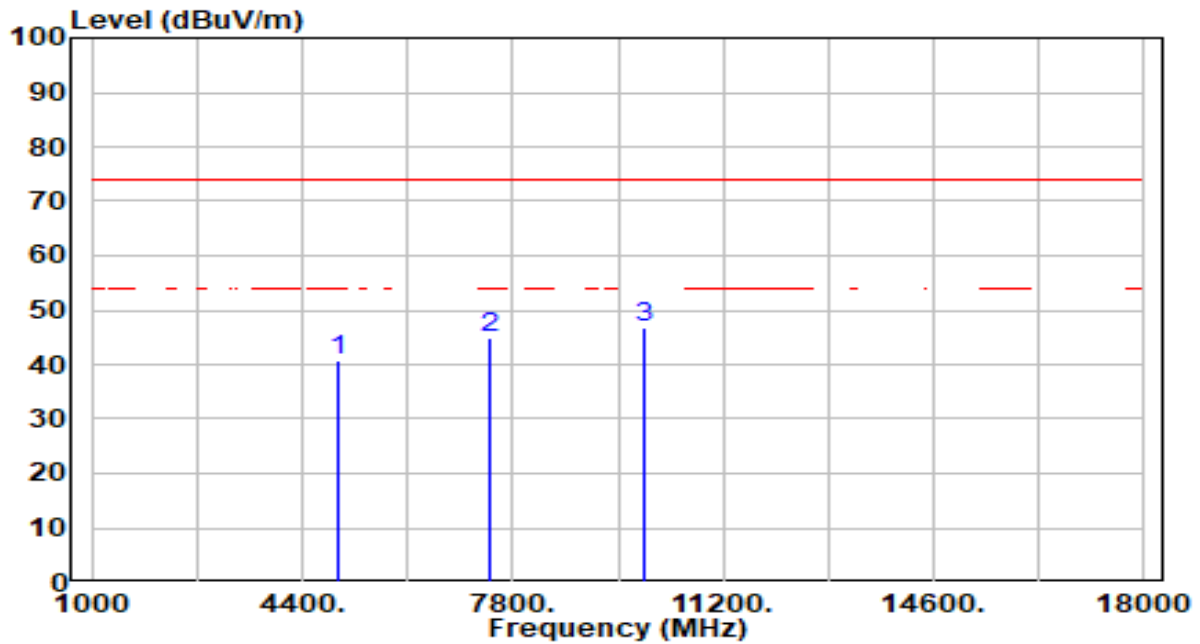

| No | Frequency (MHz) | Reading (dBuV) | C.F (dB/m) | Measurement (dBuV/m) | Margin (dB) | Limit (dBuV/m) | Height (cm) | Angle (deg) | Remark (QP/PK/AV) |
|----|-----------------|----------------|------------|----------------------|-------------|----------------|-------------|-------------|-------------------|
| 1 | 4960.000 | 40.24 | 0.59 | 40.83 | -33.17 | 74.00 | 200 | 226 | Peak |
| 2 | 7440.000 | 39.24 | 5.63 | 44.87 | -29.13 | 74.00 | 100 | 346 | Peak |
| 3 | * 9920.000 | 41.25 | 5.42 | 46.66 | -27.34 | 74.00 | 300 | 82 | Peak |

Note:

1. " *", means this data is the worst emission level.
2. C.F (Correction Factor) = Antenna Factor (dB/m) + Cable Loss (dB) – Preamplifier(dB).
3. Measurement (dBuV/m) = Reading(dBuV) + C.F (Correction Factor).
4. The emission levels of other frequencies are very lower than the limit and not show in test report.

| | | | |
|-----------|--|----------------------|--------------|
| EUT | BE11000 Ceiling Mount Wi-Fi 7 Access Point | Date of Test | 2024-06-28 |
| Factor | DRH18-E | Temp. / Humidity | 24°C /60% |
| Polarity | Horizontal | Site / Test Engineer | AC2 / You |
| Test Mode | BLE_S8_TX_CH 0 | Test Voltage | AC 120V/60Hz |

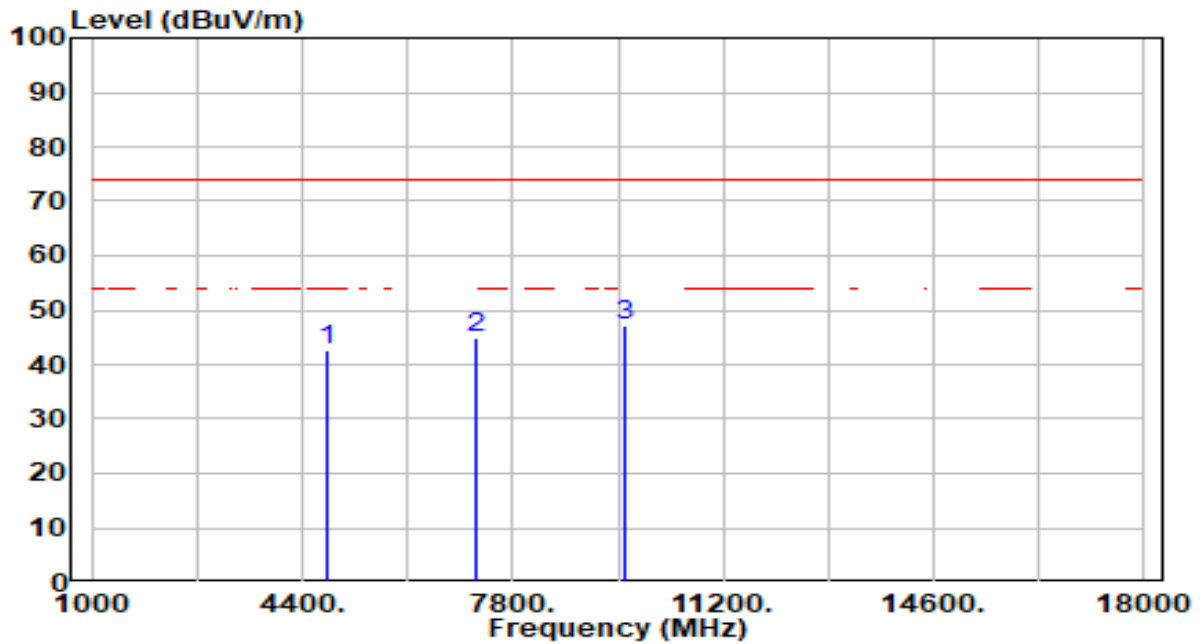

| No | Frequency (MHz) | Reading (dBuV) | C.F (dB/m) | Measurement (dBuV/m) | Margin (dB) | Limit (dBuV/m) | Height (cm) | Angle (deg) | Remark (QP/PK/AV) |
|----|-----------------|----------------|------------|----------------------|-------------|----------------|-------------|-------------|-------------------|
| 1 | 4804.000 | 42.55 | 0.18 | 42.73 | -31.27 | 74.00 | 200 | 183 | Peak |
| 2 | 7206.000 | 39.23 | 5.53 | 44.76 | -29.24 | 74.00 | 300 | 284 | Peak |
| 3 | * 9608.000 | 41.76 | 5.29 | 47.05 | -26.95 | 74.00 | 100 | 122 | Peak |

Note:

1. " *", means this data is the worst emission level.
2. C.F (Correction Factor) = Antenna Factor (dB/m) + Cable Loss (dB) – Preamplifier(dB).
3. Measurement (dBuV/m) = Reading(dBuV) + C.F (Correction Factor).
4. The emission levels of other frequencies are very lower than the limit and not show in test report.

| | | | |
|-----------|--|----------------------|--------------|
| EUT | BE11000 Ceiling Mount Wi-Fi 7 Access Point | Date of Test | 2024-06-28 |
| Factor | DRH18-E | Temp. / Humidity | 24°C /60% |
| Polarity | Vertical | Site / Test Engineer | AC2 / You |
| Test Mode | BLE_S8_TX_CH 0 | Test Voltage | AC 120V/60Hz |

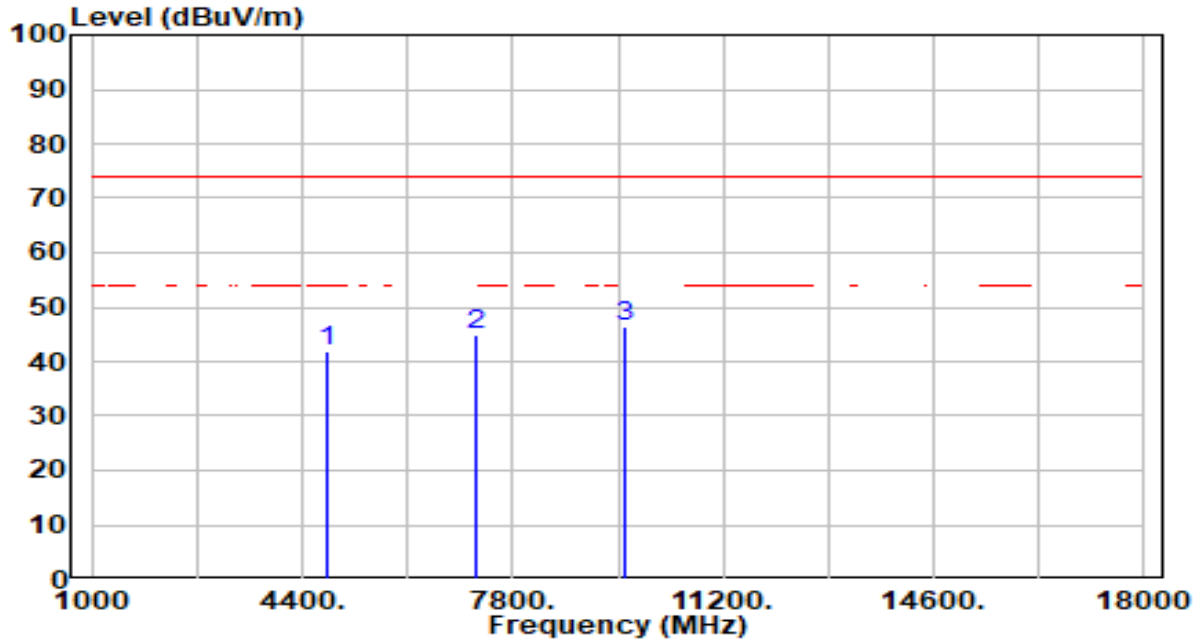

| No | Frequency (MHz) | Reading (dBuV) | C.F (dB/m) | Measurement (dBuV/m) | Margin (dB) | Limit (dBuV/m) | Height (cm) | Angle (deg) | Remark (QP/PK/AV) |
|----|-----------------|----------------|------------|----------------------|-------------|----------------|-------------|-------------|-------------------|
| 1 | 4804.000 | 41.52 | 0.18 | 41.70 | -32.30 | 74.00 | 200 | 192 | Peak |
| 2 | 7206.000 | 39.23 | 5.53 | 44.76 | -29.24 | 74.00 | 300 | 214 | Peak |
| 3 | * 9608.000 | 41.05 | 5.29 | 46.34 | -27.66 | 74.00 | 100 | 316 | Peak |

Note:

1. " *", means this data is the worst emission level.
2. C.F (Correction Factor) = Antenna Factor (dB/m) + Cable Loss (dB) – Preamplifier(dB).
3. Measurement (dBuV/m) = Reading(dBuV) + C.F (Correction Factor).
4. The emission levels of other frequencies are very lower than the limit and not show in test report.

| | | | |
|-----------|--|----------------------|--------------|
| EUT | BE11000 Ceiling Mount Wi-Fi 7 Access Point | Date of Test | 2024-06-28 |
| Factor | DRH18-E | Temp. / Humidity | 24°C /60% |
| Polarity | Horizontal | Site / Test Engineer | AC2 / You |
| Test Mode | BLE_S8_TX_CH 19 | Test Voltage | AC 120V/60Hz |

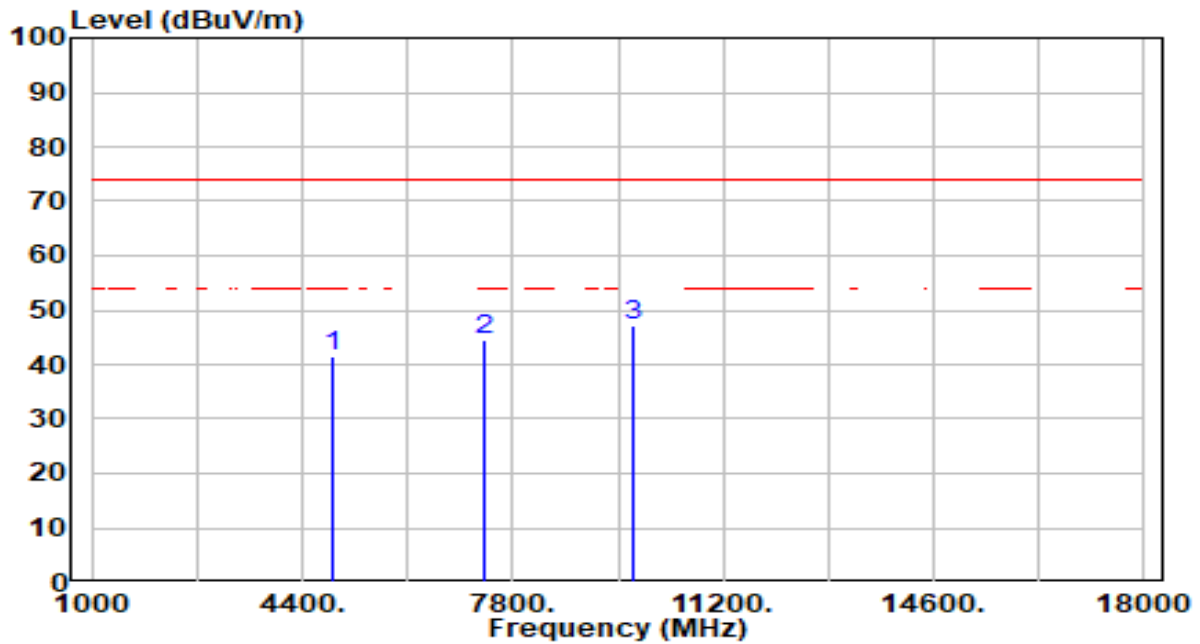

| No | Frequency (MHz) | Reading (dBuV) | C.F (dB/m) | Measurement (dBuV/m) | Margin (dB) | Limit (dBuV/m) | Height (cm) | Angle (deg) | Remark (QP/PK/AV) |
|----|-----------------|----------------|------------|----------------------|-------------|----------------|-------------|-------------|-------------------|
| 1 | 4880.000 | 40.99 | 0.38 | 41.36 | -32.64 | 74.00 | 200 | 360 | Peak |
| 2 | 7320.000 | 39.07 | 5.60 | 44.66 | -29.34 | 74.00 | 100 | 242 | Peak |
| 3 | * 9760.000 | 41.76 | 5.35 | 47.11 | -26.89 | 74.00 | 100 | 331 | Peak |

Note:

1. " *", means this data is the worst emission level.
2. C.F (Correction Factor) = Antenna Factor (dB/m) + Cable Loss (dB) – Preamplifier(dB).
3. Measurement (dBuV/m) = Reading(dBuV) + C.F (Correction Factor).
4. The emission levels of other frequencies are very lower than the limit and not show in test report.

| | | | |
|-----------|--|----------------------|--------------|
| EUT | BE11000 Ceiling Mount Wi-Fi 7 Access Point | Date of Test | 2024-06-28 |
| Factor | DRH18-E | Temp. / Humidity | 24°C /60% |
| Polarity | Vertical | Site / Test Engineer | AC2 / You |
| Test Mode | BLE_S8_TX_CH 19 | Test Voltage | AC 120V/60Hz |

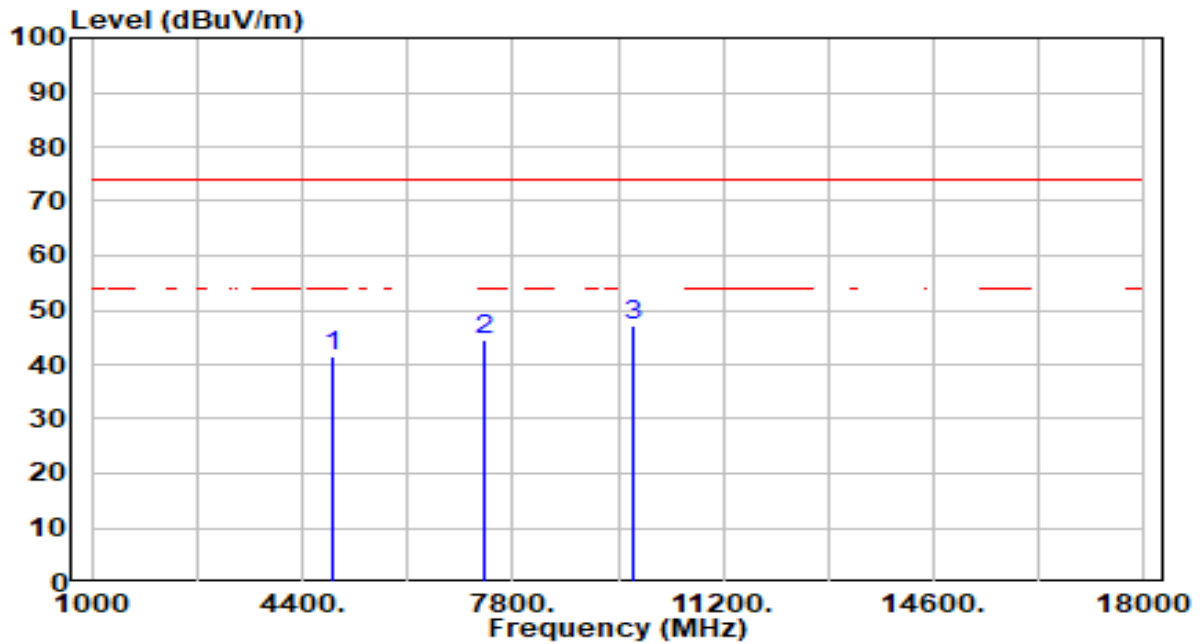

| No | Frequency (MHz) | Reading (dBuV) | C.F (dB/m) | Measurement (dBuV/m) | Margin (dB) | Limit (dBuV/m) | Height (cm) | Angle (deg) | Remark (QP/PK/AV) |
|----|-----------------|----------------|------------|----------------------|-------------|----------------|-------------|-------------|-------------------|
| 1 | 4880.000 | 41.29 | 0.38 | 41.67 | -32.33 | 74.00 | 300 | 242 | Peak |
| 2 | 7320.000 | 38.79 | 5.60 | 44.39 | -29.61 | 74.00 | 100 | 12 | Peak |
| 3 | * 9760.000 | 41.68 | 5.35 | 47.03 | -26.97 | 74.00 | 100 | 264 | Peak |

Note:

1. " *", means this data is the worst emission level.
2. C.F (Correction Factor) = Antenna Factor (dB/m) + Cable Loss (dB) – Preamplifier(dB).
3. Measurement (dBuV/m) = Reading(dBuV) + C.F (Correction Factor).
4. The emission levels of other frequencies are very lower than the limit and not show in test report.

| | | | |
|-----------|--|----------------------|--------------|
| EUT | BE11000 Ceiling Mount Wi-Fi 7 Access Point | Date of Test | 2024-06-28 |
| Factor | DRH18-E | Temp. / Humidity | 24°C /60% |
| Polarity | Horizontal | Site / Test Engineer | AC2 / You |
| Test Mode | BLE_S8_TX_CH 39 | Test Voltage | AC 120V/60Hz |

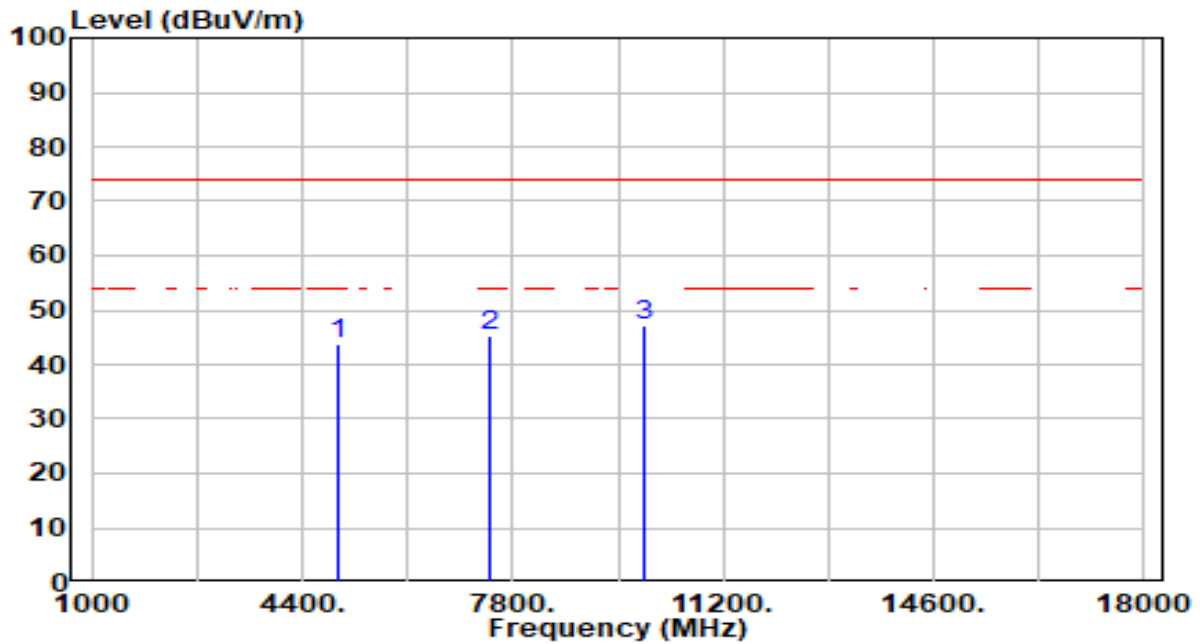

| No | Frequency (MHz) | Reading (dBuV) | C.F (dB/m) | Measurement (dBuV/m) | Margin (dB) | Limit (dBuV/m) | Height (cm) | Angle (deg) | Remark (QP/PK/AV) |
|----|-----------------|----------------|------------|----------------------|-------------|----------------|-------------|-------------|-------------------|
| 1 | 4960.000 | 43.27 | 0.59 | 43.85 | -30.15 | 74.00 | 100 | 59 | Peak |
| 2 | 7440.000 | 39.64 | 5.63 | 45.27 | -28.73 | 74.00 | 200 | 19 | Peak |
| 3 | * 9920.000 | 41.59 | 5.42 | 47.01 | -26.99 | 74.00 | 100 | 119 | Peak |

Note:

1. " *", means this data is the worst emission level.
2. C.F (Correction Factor) = Antenna Factor (dB/m) + Cable Loss (dB) – Preamplifier(dB).
3. Measurement (dBuV/m) = Reading(dBuV) + C.F (Correction Factor).
4. The emission levels of other frequencies are very lower than the limit and not show in test report.

| | | | |
|-----------|--|----------------------|--------------|
| EUT | BE11000 Ceiling Mount Wi-Fi 7 Access Point | Date of Test | 2024-06-28 |
| Factor | DRH18-E | Temp. / Humidity | 24°C /60% |
| Polarity | Vertical | Site / Test Engineer | AC2 / You |
| Test Mode | BLE_S8_TX_CH 39 | Test Voltage | AC 120V/60Hz |

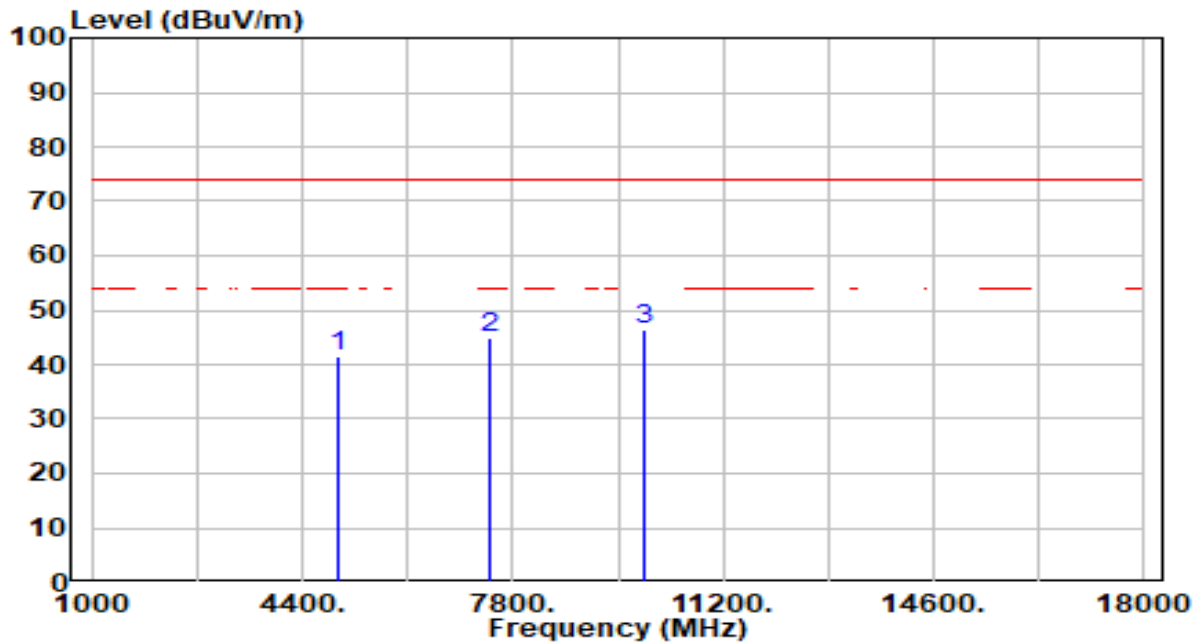

| No | Frequency (MHz) | Reading (dBuV) | C.F (dB/m) | Measurement (dBuV/m) | Margin (dB) | Limit (dBuV/m) | Height (cm) | Angle (deg) | Remark (QP/PK/AV) |
|----|-----------------|----------------|------------|----------------------|-------------|----------------|-------------|-------------|-------------------|
| 1 | 4960.000 | 41.11 | 0.59 | 41.69 | -32.31 | 74.00 | 300 | 360 | Peak |
| 2 | 7440.000 | 39.19 | 5.63 | 44.82 | -29.18 | 74.00 | 300 | 267 | Peak |
| 3 | * 9920.000 | 41.15 | 5.42 | 46.57 | -27.43 | 74.00 | 249 | 0 | Peak |

Note:

1. " *", means this data is the worst emission level.
2. C.F (Correction Factor) = Antenna Factor (dB/m) + Cable Loss (dB) – Preamplifier(dB).
3. Measurement (dBuV/m) = Reading(dBuV) + C.F (Correction Factor).
4. The emission levels of other frequencies are very lower than the limit and not show in test report.

| | | | |
|-----------|--|----------------------|---------------|
| EUT | BE11000 Ceiling Mount Wi-Fi 7 Access Point | Date of Test | 2024-06-18 |
| Factor | BBHA 9170 | Temp. / Humidity | 22°C /61% |
| Polarity | Horizontal | Site / Test Engineer | AC2 / Stanley |
| Test Mode | BLE_TX_1Mbps_CH 19 | Test Voltage | AC 120V/60Hz |

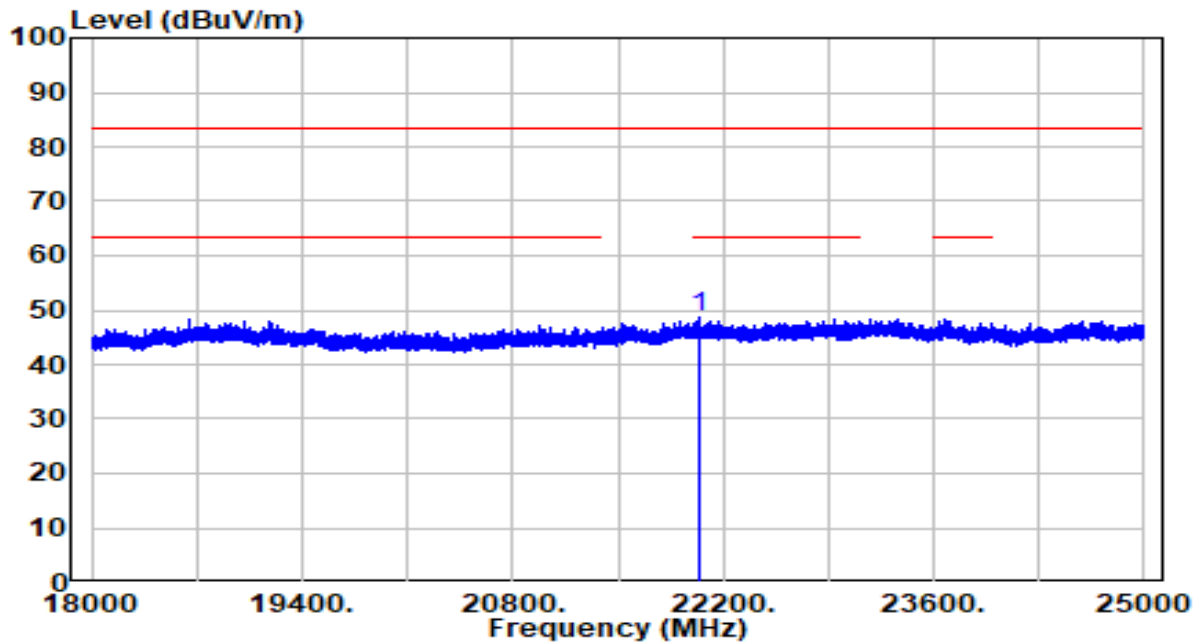

| No | Frequency (MHz) | Reading (dBuV) | C.F (dB/m) | Measurement (dBuV/m) | Margin (dB) | Limit (dBuV/m) | Height (cm) | Angle (deg) | Remark (QP/PK/AV) | |
|----|-----------------|----------------|------------|----------------------|-------------|----------------|-------------|-------------|-------------------|------|
| 1 | * | 22046.000 | 37.13 | 11.41 | 48.54 | -34.96 | 83.50 | 150 | 360 | Peak |

Note:

1. " *", means this data is the worst emission level.
2. C.F (Correction Factor) = Antenna Factor (dB/m) + Cable Loss (dB) – Preamplifier(dB).
3. Measurement (dBuV/m) = Reading(dBuV) + C.F (Correction Factor).
4. The emission levels of other frequencies are very lower than the limit and not show in test report.

| | | | |
|-----------|--|----------------------|---------------|
| EUT | BE11000 Ceiling Mount Wi-Fi 7 Access Point | Date of Test | 2024-06-18 |
| Factor | BBHA 9170 | Temp. / Humidity | 22°C /61% |
| Polarity | Vertical | Site / Test Engineer | AC2 / Stanley |
| Test Mode | BLE_TX_1Mbps_CH 19 | Test Voltage | AC 120V/60Hz |

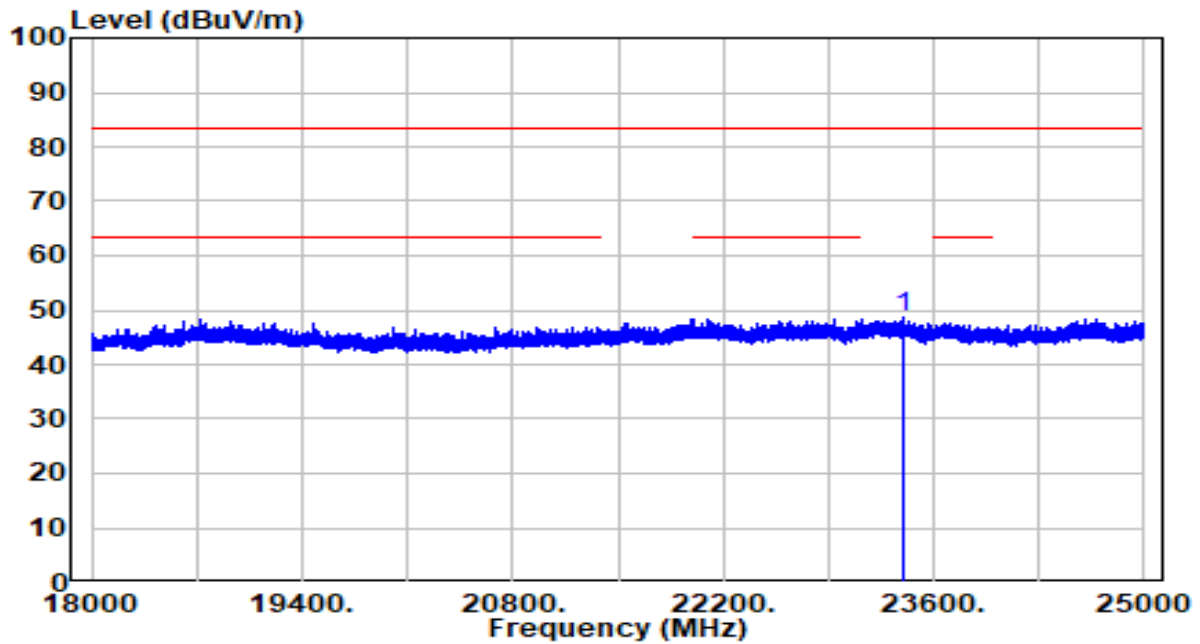

| No | Frequency (MHz) | Reading (dBuV) | C.F (dB/m) | Measurement (dBuV/m) | Margin (dB) | Limit (dBuV/m) | Height (cm) | Angle (deg) | Remark (QP/PK/AV) | |
|----|-----------------|----------------|------------|----------------------|-------------|----------------|-------------|-------------|-------------------|------|
| 1 | * | 23399.880 | 35.91 | 12.60 | 48.52 | -34.98 | 83.50 | 150 | 0 | Peak |

Note:

1. " *", means this data is the worst emission level.
2. C.F (Correction Factor) = Antenna Factor (dB/m) + Cable Loss (dB) – Preamplifier(dB).
3. Measurement (dBuV/m) = Reading(dBuV) + C.F (Correction Factor).
4. The emission levels of other frequencies are very lower than the limit and not show in test report.

7.7. Radiated Restricted Band Edge Measurement

7.7.1. Test Limit

All out of band emissions appearing in a restricted band as specified in Section 15.205 of the Title 47 CFR must not exceed the limits shown in Table per Section 15.209.

| FCC Part 15 Subpart C Paragraph 15.209 | | |
|--|----------------------|----------------------------|
| Frequency [MHz] | Field Strength [V/m] | Measured Distance [Meters] |
| 0.009 - 0.490 | 2400/F (kHz) | 300 |
| 0.490 - 1.705 | 24000/F (kHz) | 30 |
| 1.705 – 30 | 30 | 30 |
| 30 – 88 | 100 | 3 |
| 88 – 216 | 150 | 3 |
| 216 – 960 | 200 | 3 |
| Above 960 | 500 | 3 |

7.7.2. Test Procedure Used

ANSI C63.10-2013 - Section 11.13

7.7.3. Test Setting

Peak Field Strength Measurements

1. Analyzer center frequency was set to the frequency of the radiated spurious emission of interest
2. RBW = as specified in Table 1
3. VBW = 3 * RBW
4. Detector = peak
5. Sweep time = auto couple
6. Trace mode = max hold
7. Trace was allowed to stabilize

Table 1 - RBW as a function of frequency

| Frequency | RBW |
|---------------|---------------|
| 9 ~ 150 kHz | 200 ~ 300 Hz |
| 0.15 ~ 30 MHz | 9 ~ 10 kHz |
| 30 ~ 1000 MHz | 100 ~ 120 kHz |
| > 1000 MHz | 1 MHz |

Average Field Strength Measurements

1. Analyzer center frequency was set to the frequency of the radiated spurious emission of interest
2. RBW = 1MHz
3. VBW $\geq 1/T$
4. De As an alternative, the instrument may be set to linear detector mode. Ensure that video filtering is applied in linear voltage domain (rather than in a log or dB domain). Some instruments require linear display mode in order to accomplish this. Others have a setting for Average-VBW Type, which can be set to "Voltage" regardless of the display mode
5. Detector = Peak
6. Sweep time = auto
7. Trace mode = max hold
8. Allow max hold to run for at least 50 times (1/duty cycle) traces

7.7.4. Test Setup

1GHz ~ 25GHz Test Setup:

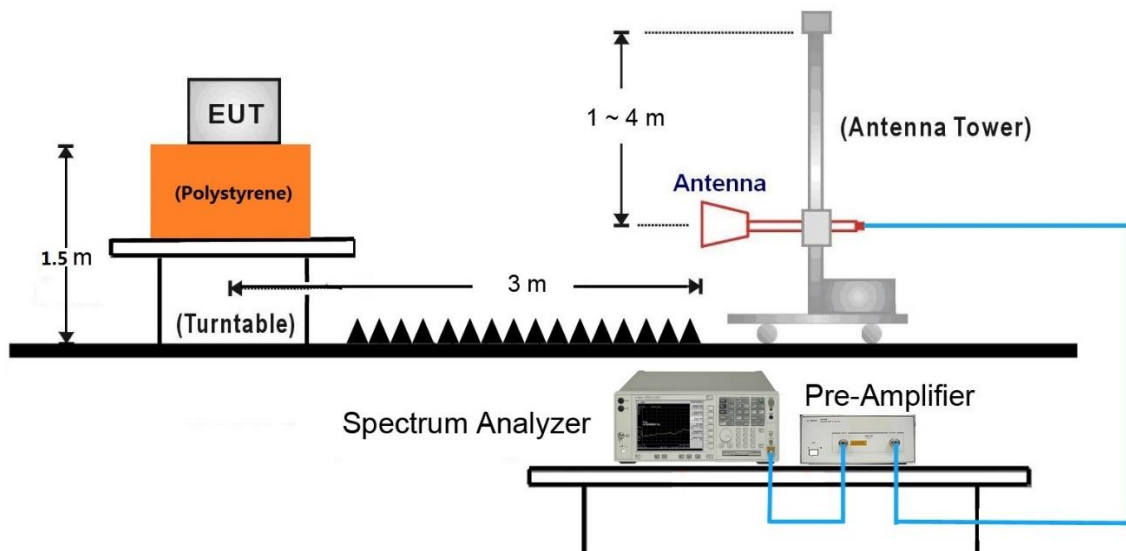

7.7.5. Test Result

| | | | |
|-----------|--|----------------------|--------------|
| EUT | BE11000 Ceiling Mount Wi-Fi 7 Access Point | Date of Test | 2024-05-29 |
| Factor | DRH18-E | Temp. / Humidity | 24°C /60% |
| Polarity | Horizontal | Site / Test Engineer | AC2 / You |
| Test Mode | BLE_1Mbps_TX_CH 0 | Test Voltage | AC 120V/60Hz |

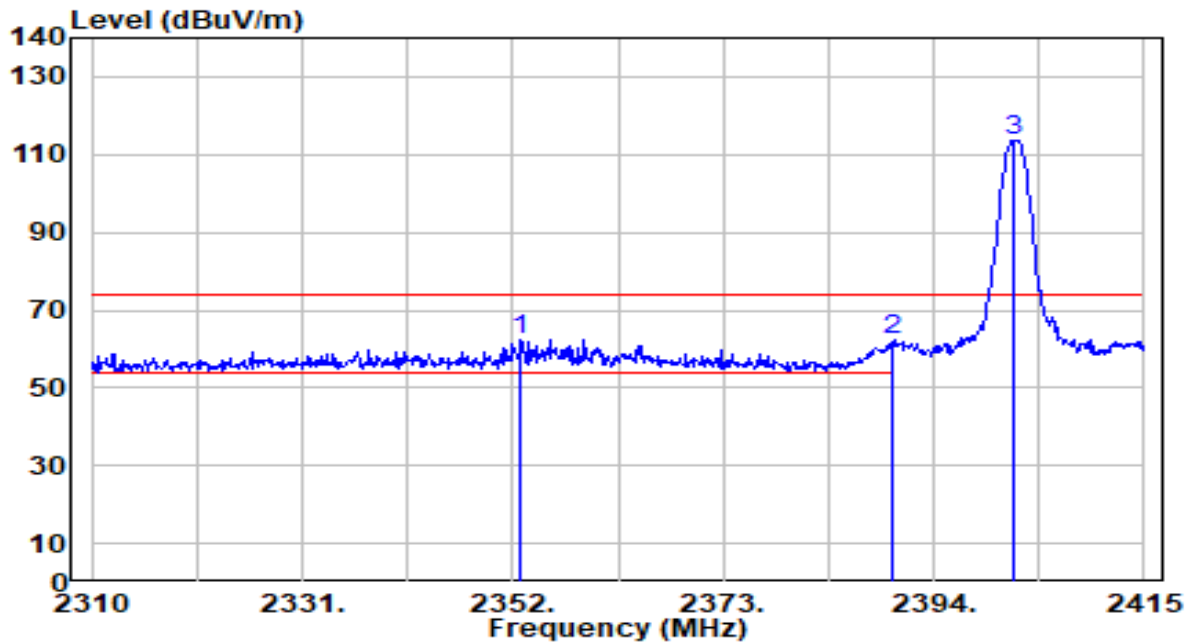

| No | Frequency (MHz) | Reading (dBuV) | C.F (dB/m) | Measurement (dBuV/m) | Margin (dB) | Limit (dBuV/m) | Height (cm) | Angle (deg) | Remark (QP/PK/AV) |
|----|-----------------|----------------|------------|----------------------|-------------|----------------|-------------|-------------|-------------------|
| 1 | * 2352.840 | 32.23 | 30.34 | 62.57 | -11.43 | 74.00 | 133 | 134 | Peak |
| 2 | 2390.000 | 31.71 | 30.45 | 62.16 | -11.84 | 74.00 | 133 | 134 | Peak |
| 3 | 2402.085 | 83.02 | 30.48 | 113.50 | N/A | N/A | 133 | 134 | Peak |

Note:

1. " *", means this data is the worst emission level.
2. C.F (Correction Factor) = Antenna Factor (dB/m) + Cable Loss (dB).
3. Measurement (dBuV/m) = Reading(dBuV) + C.F (Correction Factor).
4. The emission levels of other frequencies are very lower than the limit and not show in test report.

| | | | |
|-----------|--|----------------------|--------------|
| EUT | BE11000 Ceiling Mount Wi-Fi 7 Access Point | Date of Test | 2024-05-29 |
| Factor | DRH18-E | Temp. / Humidity | 24°C /60% |
| Polarity | Horizontal | Site / Test Engineer | AC2 / You |
| Test Mode | BLE_1Mbps_TX_CH 0 | Test Voltage | AC 120V/60Hz |

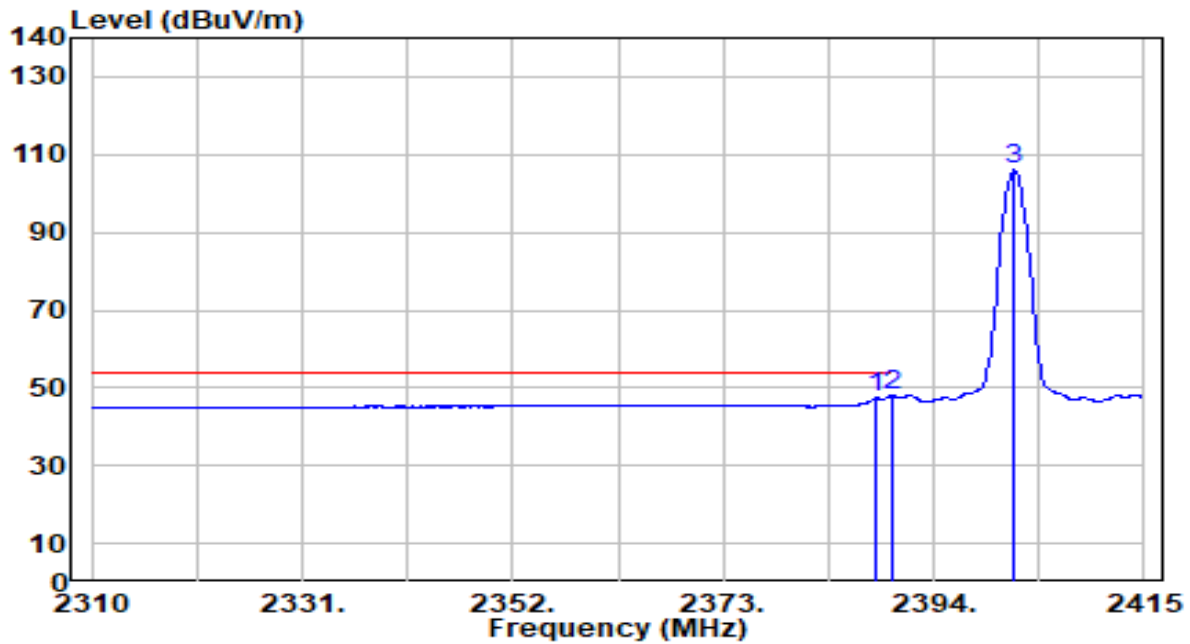

| No | Frequency (MHz) | Reading (dBuV) | C.F (dB/m) | Measurement (dBuV/m) | Margin (dB) | Limit (dBuV/m) | Height (cm) | Angle (deg) | Remark (QP/PK/AV) |
|----|-----------------|----------------|------------|----------------------|-------------|----------------|-------------|-------------|-------------------|
| 1 | 2388.330 | 16.88 | 30.44 | 47.32 | -6.68 | 54.00 | 133 | 134 | Average |
| 2 | * 2390.000 | 17.49 | 30.45 | 47.93 | -6.07 | 54.00 | 133 | 134 | Average |
| 3 | 2401.980 | 75.45 | 30.48 | 105.93 | N/A | N/A | 133 | 134 | Average |

Note:

1. " *", means this data is the worst emission level.
2. C.F (Correction Factor) = Antenna Factor (dB/m) + Cable Loss (dB).
3. Measurement (dBuV/m) = Reading(dBuV) + C.F (Correction Factor).
4. The emission levels of other frequencies are very lower than the limit and not show in test report.

| | | | |
|-----------|--|----------------------|--------------|
| EUT | BE11000 Ceiling Mount Wi-Fi 7 Access Point | Date of Test | 2024-05-29 |
| Factor | DRH18-E | Temp. / Humidity | 24°C /60% |
| Polarity | Vertical | Site / Test Engineer | AC2 / You |
| Test Mode | BLE_1Mbps_TX_CH 0 | Test Voltage | AC 120V/60Hz |

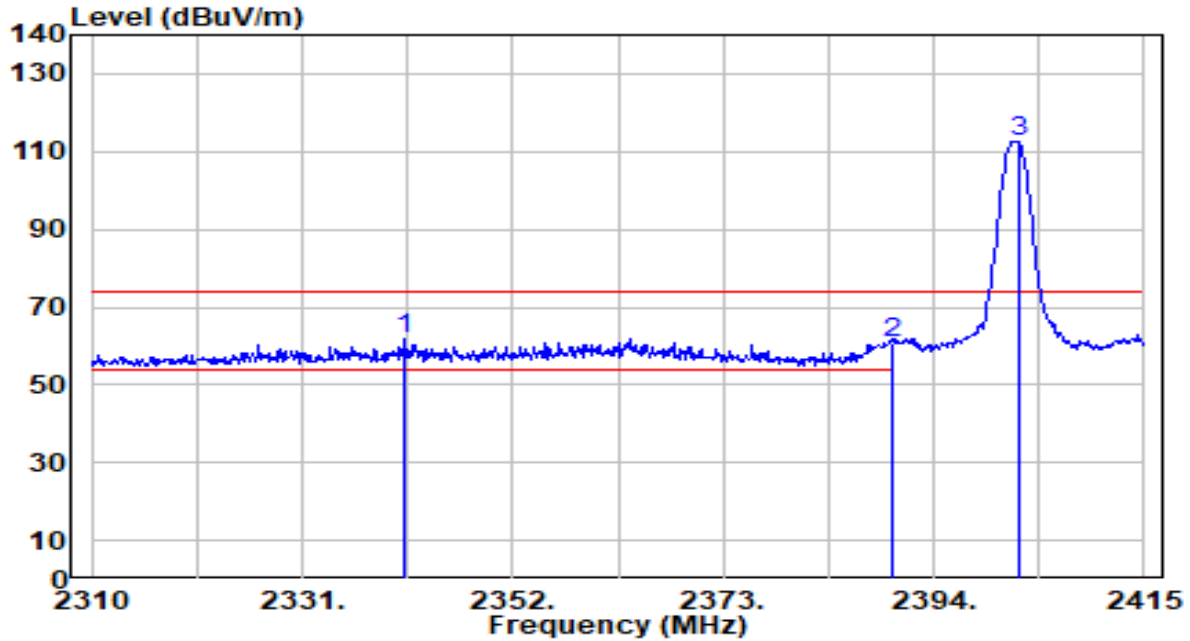

| No | Frequency (MHz) | Reading (dBuV) | C.F (dB/m) | Measurement (dBuV/m) | Margin (dB) | Limit (dBuV/m) | Height (cm) | Angle (deg) | Remark (QP/PK/AV) |
|----|-----------------|----------------|------------|----------------------|-------------|----------------|-------------|-------------|-------------------|
| 1 | * 2341.185 | 31.66 | 30.31 | 61.97 | -12.03 | 74.00 | 115 | 159 | Peak |
| 2 | 2390.000 | 30.45 | 30.45 | 60.89 | -13.11 | 74.00 | 115 | 159 | Peak |
| 3 | 2402.400 | 81.85 | 30.48 | 112.33 | N/A | N/A | 115 | 159 | Peak |

Note:

1. " *", means this data is the worst emission level.
2. C.F (Correction Factor) = Antenna Factor (dB/m) + Cable Loss (dB).
3. Measurement (dBuV/m) = Reading(dBuV) + C.F (Correction Factor).
4. The emission levels of other frequencies are very lower than the limit and not show in test report.

| | | | |
|-----------|--|----------------------|--------------|
| EUT | BE11000 Ceiling Mount Wi-Fi 7 Access Point | Date of Test | 2024-05-29 |
| Factor | DRH18-E | Temp. / Humidity | 24°C /60% |
| Polarity | Vertical | Site / Test Engineer | AC2 / You |
| Test Mode | BLE_1Mbps_TX_CH 0 | Test Voltage | AC 120V/60Hz |

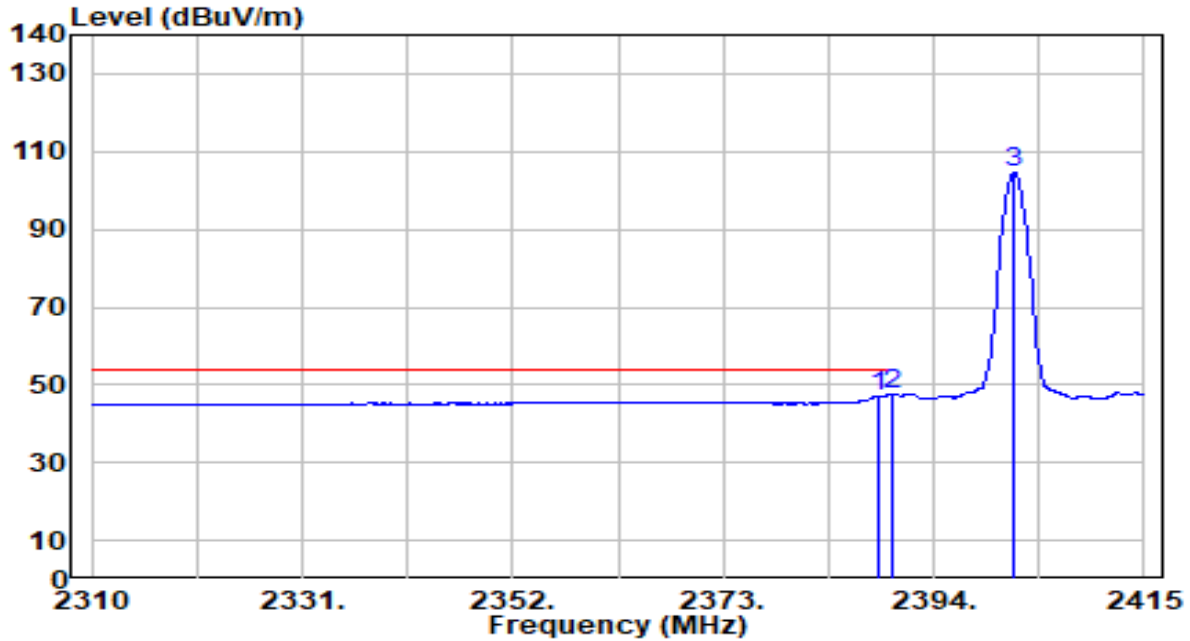

| No | Frequency (MHz) | Reading (dBuV) | C.F (dB/m) | Measurement (dBuV/m) | Margin (dB) | Limit (dBuV/m) | Height (cm) | Angle (deg) | Remark (QP/PK/AV) |
|----|-----------------|----------------|------------|----------------------|-------------|----------------|-------------|-------------|-------------------|
| 1 | 2388.435 | 16.73 | 30.44 | 47.17 | -6.83 | 54.00 | 115 | 159 | Average |
| 2 | * 2390.000 | 17.25 | 30.45 | 47.69 | -6.31 | 54.00 | 115 | 159 | Average |
| 3 | 2401.980 | 74.21 | 30.48 | 104.69 | N/A | N/A | 115 | 159 | Average |

Note:

1. " *", means this data is the worst emission level.
2. C.F (Correction Factor) = Antenna Factor (dB/m) + Cable Loss (dB).
3. Measurement (dBuV/m) = Reading(dBuV) + C.F (Correction Factor).
4. The emission levels of other frequencies are very lower than the limit and not show in test report.

| | | | |
|-----------|--|----------------------|--------------|
| EUT | BE11000 Ceiling Mount Wi-Fi 7 Access Point | Date of Test | 2024-05-29 |
| Factor | DRH18-E | Temp. / Humidity | 24°C /60% |
| Polarity | Horizontal | Site / Test Engineer | AC2 / You |
| Test Mode | BLE_1Mbps_TX_CH 39 | Test Voltage | AC 120V/60Hz |

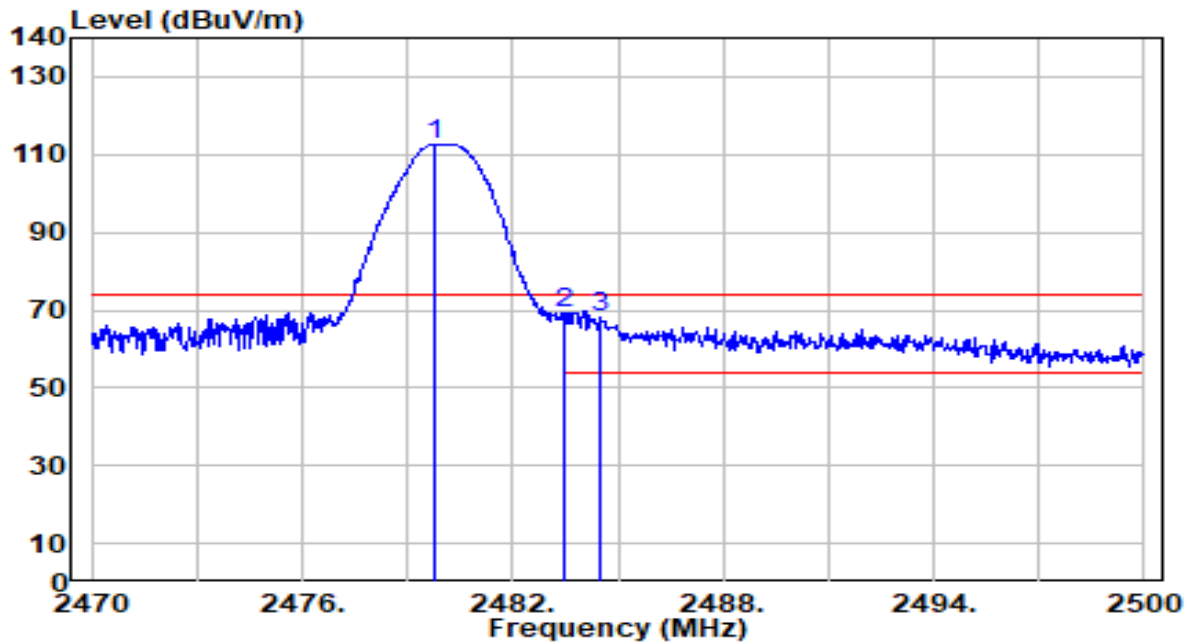

| No | Frequency (MHz) | Reading (dBuV) | C.F (dB/m) | Measurement (dBuV/m) | Margin (dB) | Limit (dBuV/m) | Height (cm) | Angle (deg) | Remark (QP/PK/AV) |
|----|-----------------|----------------|------------|----------------------|-------------|----------------|-------------|-------------|-------------------|
| 1 | 2479.780 | 82.05 | 30.58 | 112.63 | N/A | N/A | 141 | 132 | Peak |
| 2 | * 2483.500 | 38.68 | 30.59 | 69.27 | -4.73 | 74.00 | 141 | 132 | Peak |
| 3 | 2484.520 | 37.77 | 30.59 | 68.35 | -5.65 | 74.00 | 141 | 132 | Peak |

Note:

1. " *" , means this data is the worst emission level.
2. C.F (Correction Factor) = Antenna Factor (dB/m) + Cable Loss (dB).
3. Measurement (dBuV/m) = Reading(dBuV) + C.F (Correction Factor).
4. The emission levels of other frequencies are very lower than the limit and not show in test report.

| | | | |
|-----------|--|----------------------|--------------|
| EUT | BE11000 Ceiling Mount Wi-Fi 7 Access Point | Date of Test | 2024-05-29 |
| Factor | DRH18-E | Temp. / Humidity | 24°C /60% |
| Polarity | Horizontal | Site / Test Engineer | AC2 / You |
| Test Mode | BLE_1Mbps_TX_CH 39 | Test Voltage | AC 120V/60Hz |

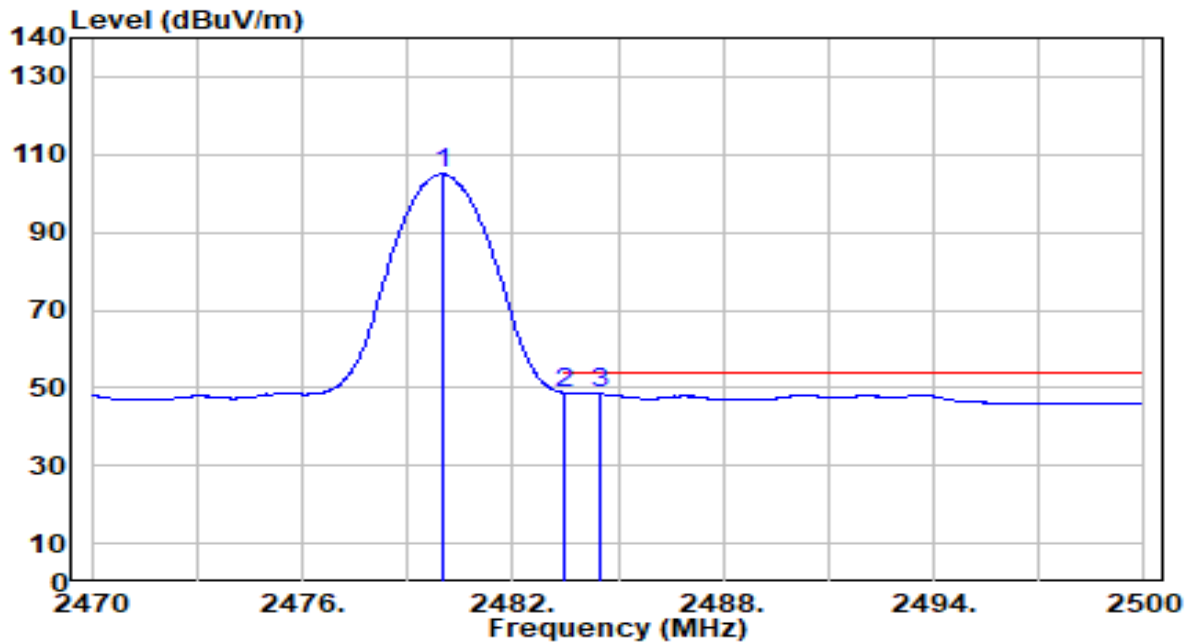

| No | Frequency (MHz) | Reading (dBuV) | C.F (dB/m) | Measurement (dBuV/m) | Margin (dB) | Limit (dBuV/m) | Height (cm) | Angle (deg) | Remark (QP/PK/AV) |
|----|-----------------|----------------|------------|----------------------|-------------|----------------|-------------|-------------|-------------------|
| 1 | 2479.990 | 74.35 | 30.58 | 104.93 | N/A | N/A | 141 | 132 | Average |
| 2 | * 2483.500 | 18.16 | 30.59 | 48.75 | -5.25 | 54.00 | 141 | 132 | Average |
| 3 | 2484.520 | 17.81 | 30.59 | 48.40 | -5.60 | 54.00 | 141 | 132 | Average |

Note:

1. " *", means this data is the worst emission level.
2. C.F (Correction Factor) = Antenna Factor (dB/m) + Cable Loss (dB).
3. Measurement (dBuV/m) = Reading(dBuV) + C.F (Correction Factor).
4. The emission levels of other frequencies are very lower than the limit and not show in test report.

| | | | |
|-----------|--|----------------------|--------------|
| EUT | BE11000 Ceiling Mount Wi-Fi 7 Access Point | Date of Test | 2024-05-29 |
| Factor | DRH18-E | Temp. / Humidity | 24°C /60% |
| Polarity | Vertical | Site / Test Engineer | AC2 / You |
| Test Mode | BLE_1Mbps_TX_CH 39 | Test Voltage | AC 120V/60Hz |

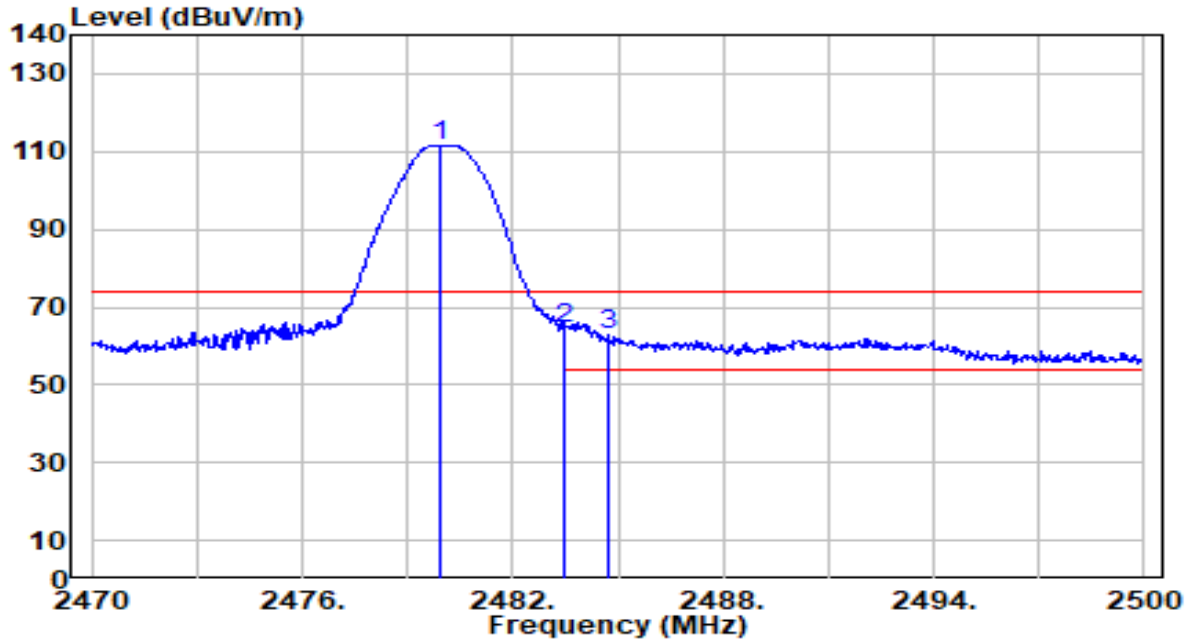

| No | Frequency (MHz) | Reading (dBuV) | C.F (dB/m) | Measurement (dBuV/m) | Margin (dB) | Limit (dBuV/m) | Height (cm) | Angle (deg) | Remark (QP/PK/AV) |
|----|-----------------|----------------|------------|----------------------|-------------|----------------|-------------|-------------|-------------------|
| 1 | 2479.960 | 81.03 | 30.58 | 111.62 | N/A | N/A | 135 | 162 | Peak |
| 2 | * 2483.500 | 34.03 | 30.59 | 64.62 | -9.38 | 74.00 | 135 | 162 | Peak |
| 3 | 2484.730 | 32.07 | 30.59 | 62.66 | -11.34 | 74.00 | 135 | 162 | Peak |

Note:

1. " *", means this data is the worst emission level.
2. C.F (Correction Factor) = Antenna Factor (dB/m) + Cable Loss (dB).
3. Measurement (dBuV/m) = Reading(dBuV) + C.F (Correction Factor).
4. The emission levels of other frequencies are very lower than the limit and not show in test report.

| | | | |
|-----------|--|----------------------|--------------|
| EUT | BE11000 Ceiling Mount Wi-Fi 7 Access Point | Date of Test | 2024-05-29 |
| Factor | DRH18-E | Temp. / Humidity | 24°C /60% |
| Polarity | Vertical | Site / Test Engineer | AC2 / You |
| Test Mode | BLE_1Mbps_TX_CH 39 | Test Voltage | AC 120V/60Hz |

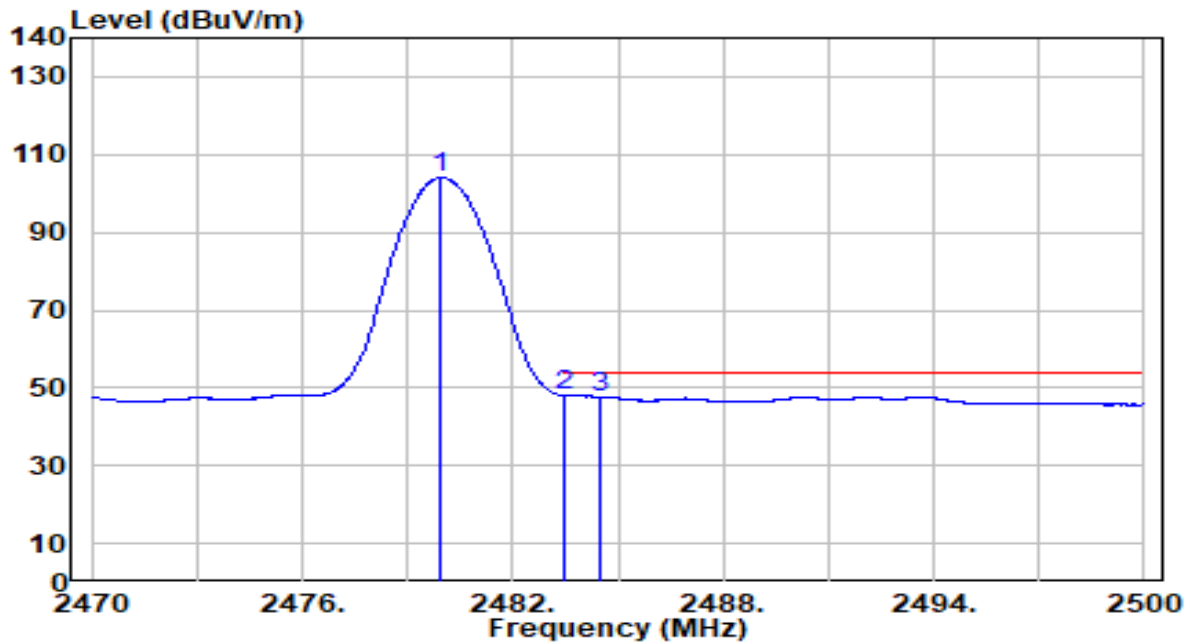

| No | Frequency (MHz) | Reading (dBuV) | C.F (dB/m) | Measurement (dBuV/m) | Margin (dB) | Limit (dBuV/m) | Height (cm) | Angle (deg) | Remark (QP/PK/AV) |
|----|-----------------|----------------|------------|----------------------|-------------|----------------|-------------|-------------|-------------------|
| 1 | 2479.960 | 73.45 | 30.58 | 104.04 | N/A | N/A | 135 | 162 | Average |
| 2 | * 2483.500 | 17.42 | 30.59 | 48.00 | -6.00 | 54.00 | 135 | 162 | Average |
| 3 | 2484.520 | 17.11 | 30.59 | 47.70 | -6.30 | 54.00 | 135 | 162 | Average |

Note:

1. " *", means this data is the worst emission level.
2. C.F (Correction Factor) = Antenna Factor (dB/m) + Cable Loss (dB).
3. Measurement (dBuV/m) = Reading(dBuV) + C.F (Correction Factor).
4. The emission levels of other frequencies are very lower than the limit and not show in test report.

| | | | |
|-----------|--|----------------------|--------------|
| EUT | BE11000 Ceiling Mount Wi-Fi 7 Access Point | Date of Test | 2024-05-29 |
| Factor | DRH18-E | Temp. / Humidity | 24°C /60% |
| Polarity | Horizontal | Site / Test Engineer | AC2 / You |
| Test Mode | BLE_S=2_TX_CH 0 | Test Voltage | AC 120V/60Hz |

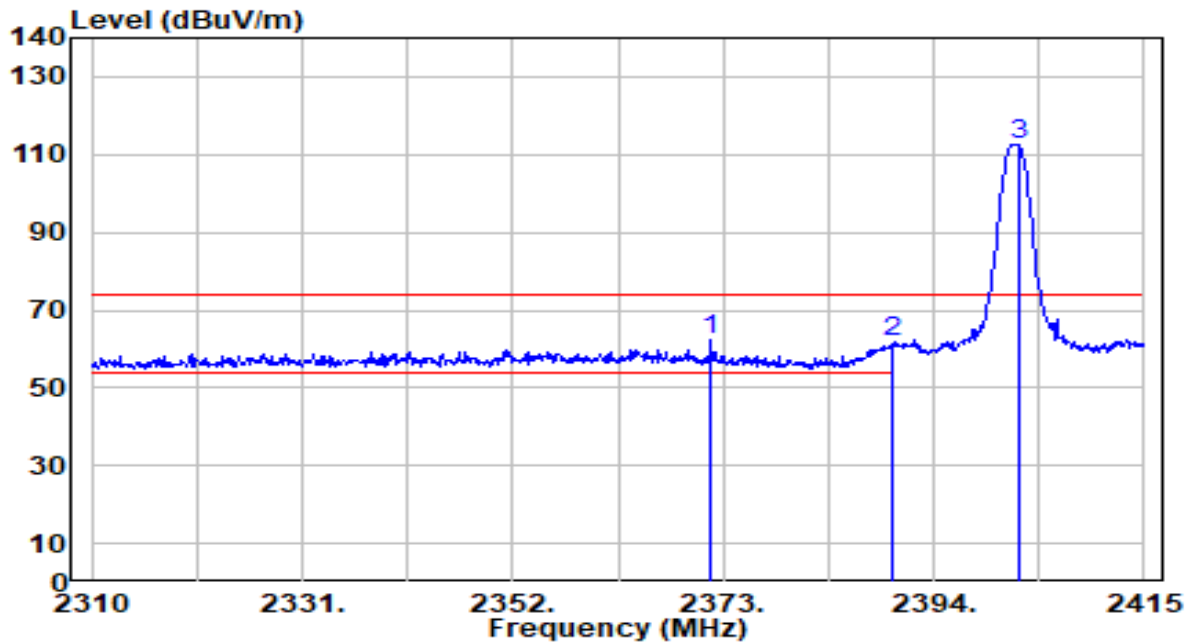

| No | Frequency (MHz) | Reading (dBuV) | C.F (dB/m) | Measurement (dBuV/m) | Margin (dB) | Limit (dBuV/m) | Height (cm) | Angle (deg) | Remark (QP/PK/AV) |
|----|-----------------|----------------|------------|----------------------|-------------|----------------|-------------|-------------|-------------------|
| 1 | * 2371.740 | 31.75 | 30.40 | 62.15 | -11.85 | 74.00 | 135 | 134 | Peak |
| 2 | 2390.000 | 31.33 | 30.45 | 61.77 | -12.23 | 74.00 | 135 | 134 | Peak |
| 3 | 2402.400 | 82.21 | 30.48 | 112.69 | N/A | N/A | 135 | 134 | Peak |

Note:

1. " *", means this data is the worst emission level.
2. C.F (Correction Factor) = Antenna Factor (dB/m) + Cable Loss (dB).
3. Measurement (dBuV/m) = Reading(dBuV) + C.F (Correction Factor).
4. The emission levels of other frequencies are very lower than the limit and not show in test report.

| | | | |
|-----------|--|----------------------|--------------|
| EUT | BE11000 Ceiling Mount Wi-Fi 7 Access Point | Date of Test | 2024-05-29 |
| Factor | DRH18-E | Temp. / Humidity | 24°C /60% |
| Polarity | Horizontal | Site / Test Engineer | AC2 / You |
| Test Mode | BLE_S=2_TX_CH 0 | Test Voltage | AC 120V/60Hz |

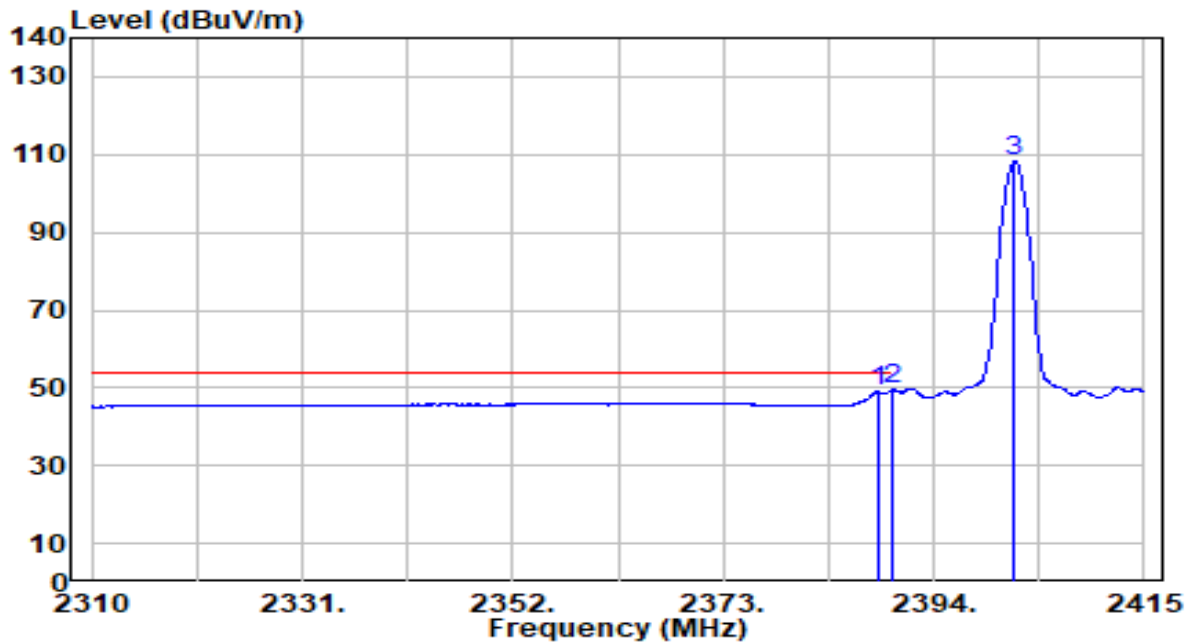

| No | Frequency (MHz) | Reading (dBuV) | C.F (dB/m) | Measurement (dBuV/m) | Margin (dB) | Limit (dBuV/m) | Height (cm) | Angle (deg) | Remark (QP/PK/AV) |
|----|-----------------|----------------|------------|----------------------|-------------|----------------|-------------|-------------|-------------------|
| 1 | 2388.435 | 18.50 | 30.44 | 48.94 | -5.06 | 54.00 | 135 | 134 | Average |
| 2 | * 2390.000 | 18.96 | 30.45 | 49.41 | -4.59 | 54.00 | 135 | 134 | Average |
| 3 | 2402.085 | 77.76 | 30.48 | 108.24 | N/A | N/A | 135 | 134 | Average |

Note:

1. " *", means this data is the worst emission level.
2. C.F (Correction Factor) = Antenna Factor (dB/m) + Cable Loss (dB).
3. Measurement (dBuV/m) = Reading(dBuV) + C.F (Correction Factor).
4. The emission levels of other frequencies are very lower than the limit and not show in test report.

| | | | |
|-----------|--|----------------------|--------------|
| EUT | BE11000 Ceiling Mount Wi-Fi 7 Access Point | Date of Test | 2024-05-29 |
| Factor | DRH18-E | Temp. / Humidity | 24°C /60% |
| Polarity | Vertical | Site / Test Engineer | AC2 / You |
| Test Mode | BLE_S=2_TX_CH 0 | Test Voltage | AC 120V/60Hz |

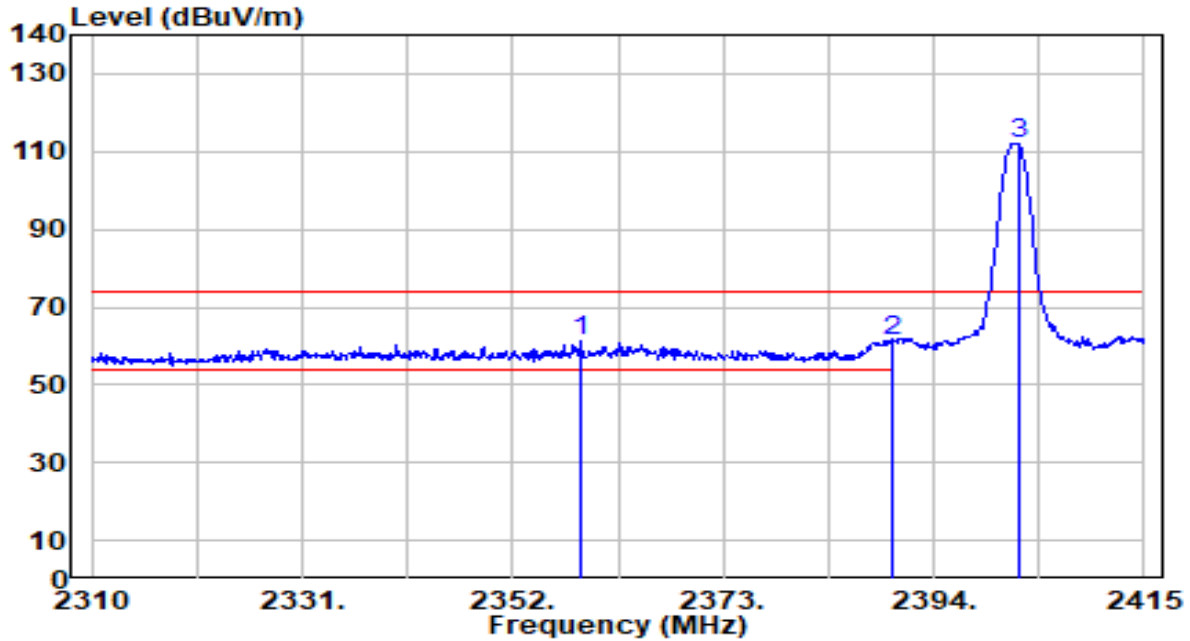

| No | Frequency (MHz) | Reading (dBuV) | C.F (dB/m) | Measurement (dBuV/m) | Margin (dB) | Limit (dBuV/m) | Height (cm) | Angle (deg) | Remark (QP/PK/AV) |
|----|-----------------|----------------|------------|----------------------|-------------|----------------|-------------|-------------|-------------------|
| 1 | 2358.720 | 30.97 | 30.36 | 61.33 | -12.67 | 74.00 | 115 | 163 | Peak |
| 2 | * 2390.000 | 30.93 | 30.45 | 61.38 | -12.62 | 74.00 | 115 | 163 | Peak |
| 3 | 2402.400 | 81.42 | 30.48 | 111.90 | N/A | N/A | 115 | 163 | Peak |

Note:

1. " *" , means this data is the worst emission level.
2. C.F (Correction Factor) = Antenna Factor (dB/m) + Cable Loss (dB).
3. Measurement (dBuV/m) = Reading(dBuV) + C.F (Correction Factor).
4. The emission levels of other frequencies are very lower than the limit and not show in test report.

| | | | |
|-----------|--|----------------------|--------------|
| EUT | BE11000 Ceiling Mount Wi-Fi 7 Access Point | Date of Test | 2024-05-29 |
| Factor | DRH18-E | Temp. / Humidity | 24°C /60% |
| Polarity | Vertical | Site / Test Engineer | AC2 / You |
| Test Mode | BLE_S=2_TX_CH 0 | Test Voltage | AC 120V/60Hz |

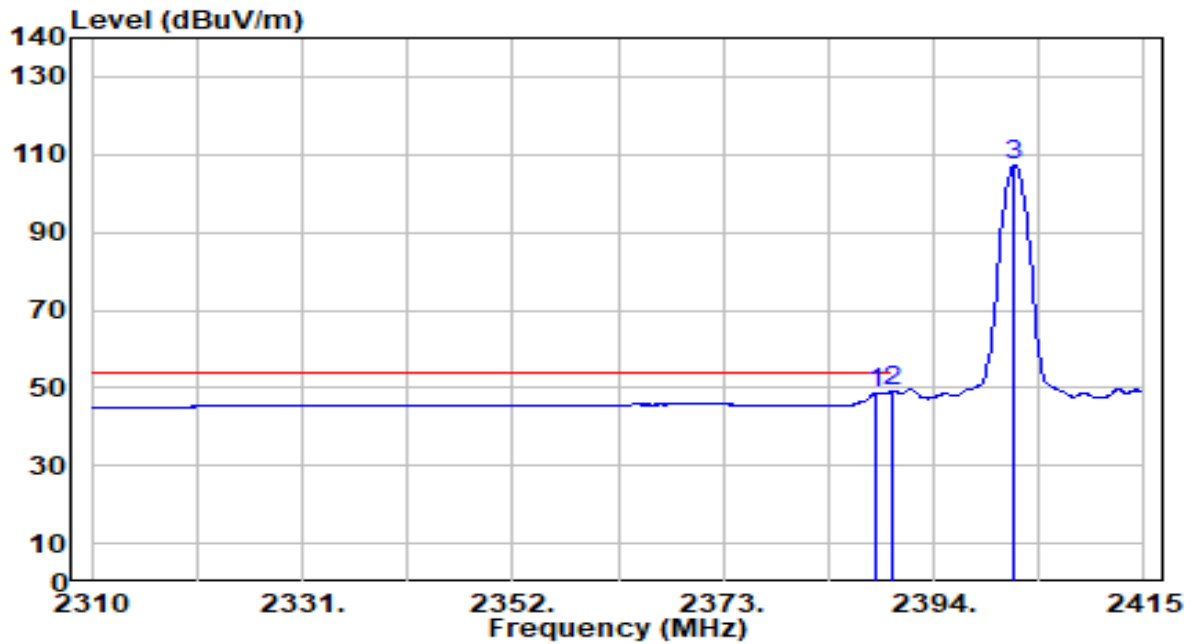

| No | Frequency (MHz) | Reading (dBuV) | C.F (dB/m) | Measurement (dBuV/m) | Margin (dB) | Limit (dBuV/m) | Height (cm) | Angle (deg) | Remark (QP/PK/AV) |
|----|-----------------|----------------|------------|----------------------|-------------|----------------|-------------|-------------|-------------------|
| 1 | 2388.330 | 18.39 | 30.44 | 48.84 | -5.16 | 54.00 | 115 | 163 | Average |
| 2 | * 2390.000 | 18.73 | 30.45 | 49.17 | -4.83 | 54.00 | 115 | 163 | Average |
| 3 | 2402.085 | 76.87 | 30.48 | 107.35 | N/A | N/A | 115 | 163 | Average |

Note:

1. " *", means this data is the worst emission level.
2. C.F (Correction Factor) = Antenna Factor (dB/m) + Cable Loss (dB).
3. Measurement (dBuV/m) = Reading(dBuV) + C.F (Correction Factor).
4. The emission levels of other frequencies are very lower than the limit and not show in test report.

| | | | |
|-----------|--|----------------------|--------------|
| EUT | BE11000 Ceiling Mount Wi-Fi 7 Access Point | Date of Test | 2024-05-29 |
| Factor | DRH18-E | Temp. / Humidity | 24°C /60% |
| Polarity | Horizontal | Site / Test Engineer | AC2 / You |
| Test Mode | BLE_S=2_TX_CH 39 | Test Voltage | AC 120V/60Hz |

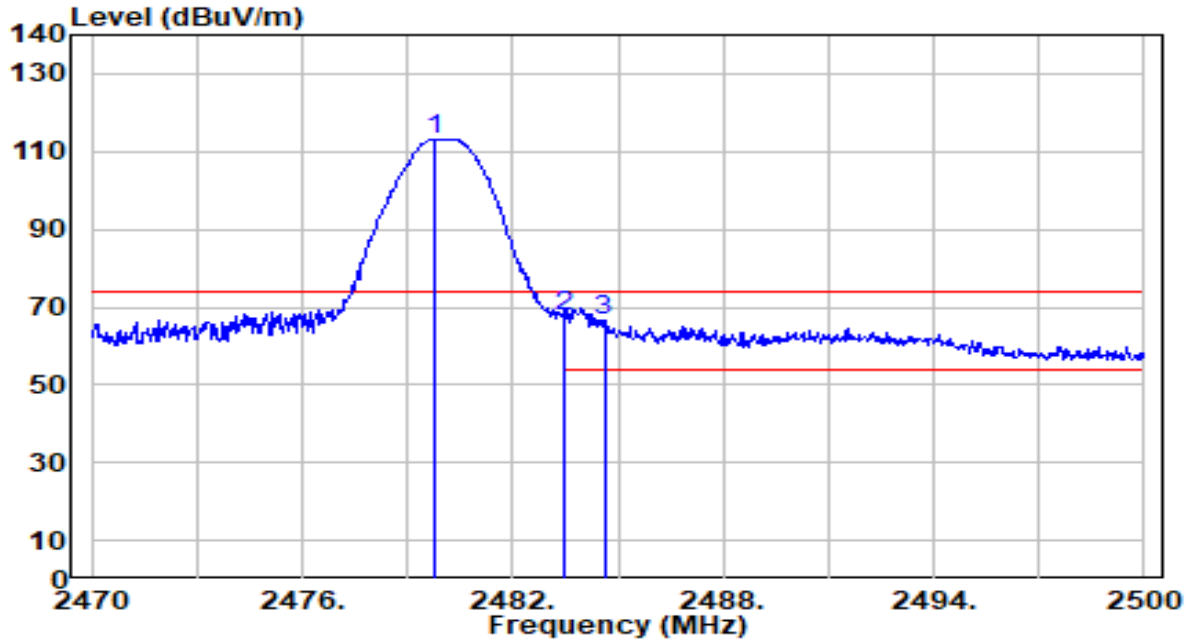

| No | Frequency (MHz) | Reading (dBuV) | C.F (dB/m) | Measurement (dBuV/m) | Margin (dB) | Limit (dBuV/m) | Height (cm) | Angle (deg) | Remark (QP/PK/AV) |
|----|-----------------|----------------|------------|----------------------|-------------|----------------|-------------|-------------|-------------------|
| 1 | 2479.810 | 82.54 | 30.58 | 113.12 | N/A | N/A | 142 | 126 | Peak |
| 2 | * 2483.500 | 36.89 | 30.59 | 67.48 | -6.52 | 74.00 | 142 | 126 | Peak |
| 3 | 2484.610 | 36.22 | 30.59 | 66.81 | -7.19 | 74.00 | 142 | 126 | Peak |

Note:

1. " *", means this data is the worst emission level.
2. C.F (Correction Factor) = Antenna Factor (dB/m) + Cable Loss (dB).
3. Measurement (dBuV/m) = Reading(dBuV) + C.F (Correction Factor).
4. The emission levels of other frequencies are very lower than the limit and not show in test report.

| | | | |
|-----------|--|----------------------|--------------|
| EUT | BE11000 Ceiling Mount Wi-Fi 7 Access Point | Date of Test | 2024-05-29 |
| Factor | DRH18-E | Temp. / Humidity | 24°C /60% |
| Polarity | Horizontal | Site / Test Engineer | AC2 / You |
| Test Mode | BLE_S=2_TX_CH 39 | Test Voltage | AC 120V/60Hz |

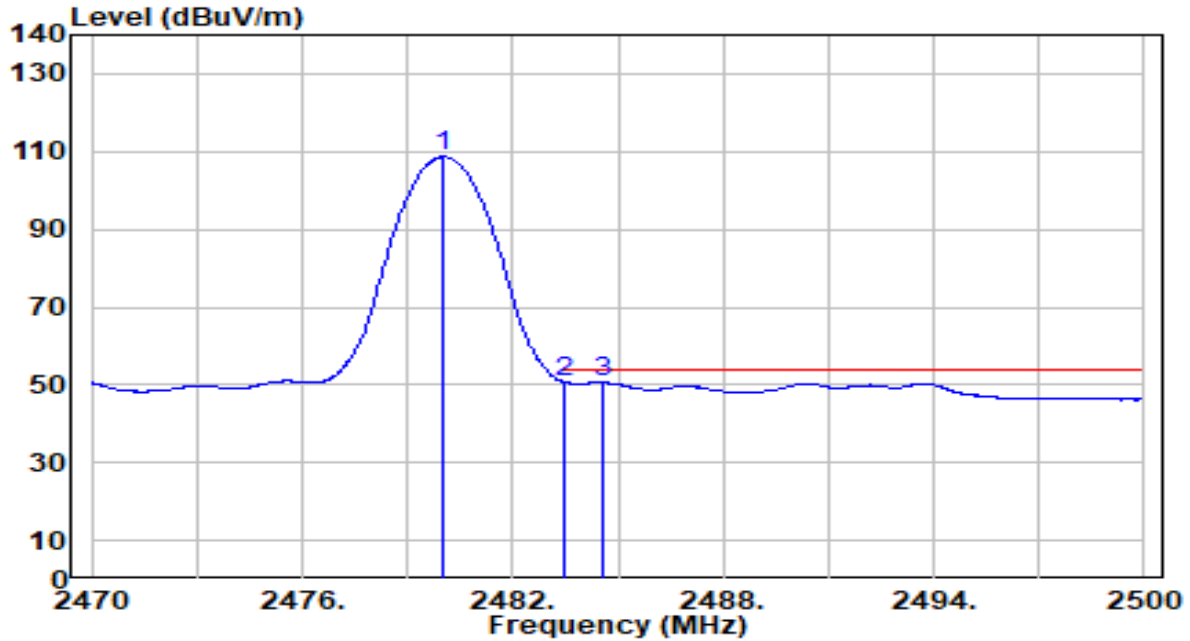

| No | Frequency (MHz) | Reading (dBuV) | C.F (dB/m) | Measurement (dBuV/m) | Margin (dB) | Limit (dBuV/m) | Height (cm) | Angle (deg) | Remark (QP/PK/AV) |
|----|-----------------|----------------|------------|----------------------|-------------|----------------|-------------|-------------|-------------------|
| 1 | 2480.020 | 78.05 | 30.58 | 108.63 | N/A | N/A | 142 | 126 | Average |
| 2 | * 2483.500 | 20.01 | 30.59 | 50.60 | -3.40 | 54.00 | 142 | 126 | Average |
| 3 | 2484.550 | 19.98 | 30.59 | 50.57 | -3.43 | 54.00 | 142 | 126 | Average |

Note:

1. " *", means this data is the worst emission level.
2. C.F (Correction Factor) = Antenna Factor (dB/m) + Cable Loss (dB).
3. Measurement (dBuV/m) = Reading(dBuV) + C.F (Correction Factor).
4. The emission levels of other frequencies are very lower than the limit and not show in test report.

| | | | |
|-----------|--|----------------------|--------------|
| EUT | BE11000 Ceiling Mount Wi-Fi 7 Access Point | Date of Test | 2024-05-29 |
| Factor | DRH18-E | Temp. / Humidity | 24°C /60% |
| Polarity | Vertical | Site / Test Engineer | AC2 / You |
| Test Mode | BLE_S=2_TX_CH 39 | Test Voltage | AC 120V/60Hz |

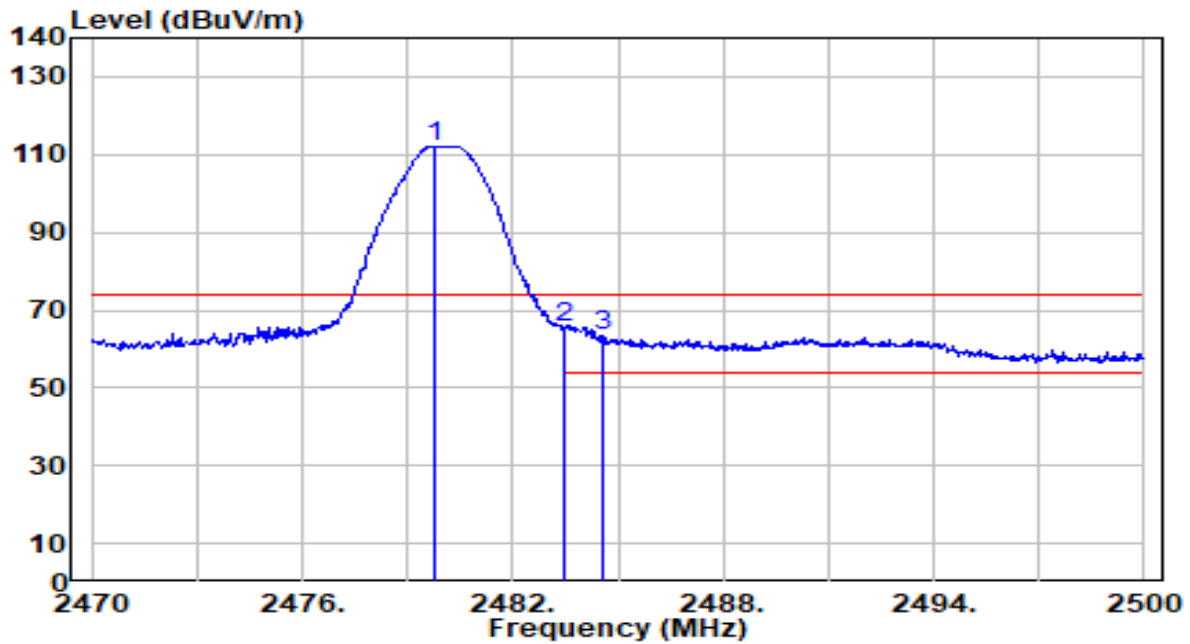

| No | Frequency (MHz) | Reading (dBuV) | C.F (dB/m) | Measurement (dBuV/m) | Margin (dB) | Limit (dBuV/m) | Height (cm) | Angle (deg) | Remark (QP/PK/AV) |
|----|-----------------|----------------|------------|----------------------|-------------|----------------|-------------|-------------|-------------------|
| 1 | 2479.810 | 81.67 | 30.58 | 112.25 | N/A | N/A | 116 | 165 | Peak |
| 2 | * 2483.500 | 34.90 | 30.59 | 65.48 | -8.52 | 74.00 | 116 | 165 | Peak |
| 3 | 2484.550 | 32.68 | 30.59 | 63.27 | -10.73 | 74.00 | 116 | 165 | Peak |

Note:

1. " *", means this data is the worst emission level.
2. C.F (Correction Factor) = Antenna Factor (dB/m) + Cable Loss (dB).
3. Measurement (dBuV/m) = Reading(dBuV) + C.F (Correction Factor).
4. The emission levels of other frequencies are very lower than the limit and not show in test report.

| | | | |
|-----------|--|----------------------|--------------|
| EUT | BE11000 Ceiling Mount Wi-Fi 7 Access Point | Date of Test | 2024-05-29 |
| Factor | DRH18-E | Temp. / Humidity | 24°C /60% |
| Polarity | Vertical | Site / Test Engineer | AC2 / You |
| Test Mode | BLE_S=2_TX_CH 39 | Test Voltage | AC 120V/60Hz |

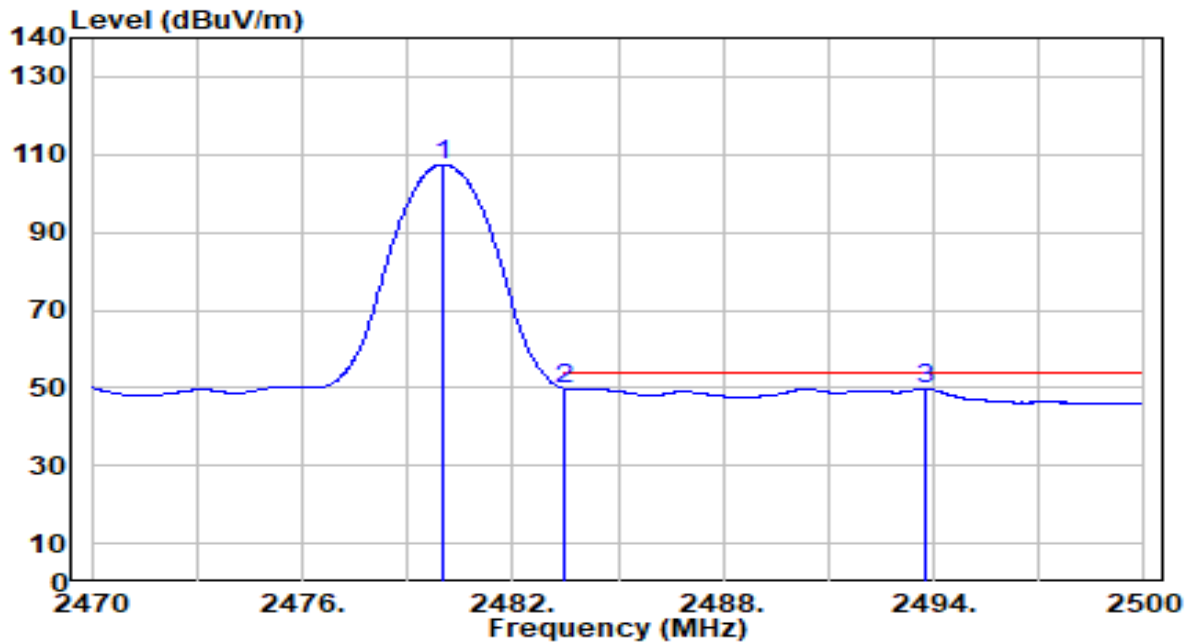

| No | Frequency (MHz) | Reading (dBuV) | C.F (dB/m) | Measurement (dBuV/m) | Margin (dB) | Limit (dBuV/m) | Height (cm) | Angle (deg) | Remark (QP/PK/AV) |
|----|-----------------|----------------|------------|----------------------|-------------|----------------|-------------|-------------|-------------------|
| 1 | 2480.020 | 76.86 | 30.58 | 107.44 | N/A | N/A | 116 | 165 | Average |
| 2 | 2483.500 | 19.12 | 30.59 | 49.70 | -4.30 | 54.00 | 116 | 165 | Average |
| 3 | * 2493.790 | 19.15 | 30.60 | 49.75 | -4.25 | 54.00 | 116 | 165 | Average |

Note:

1. " *", means this data is the worst emission level.
2. C.F (Correction Factor) = Antenna Factor (dB/m) + Cable Loss (dB).
3. Measurement (dBuV/m) = Reading(dBuV) + C.F (Correction Factor).
4. The emission levels of other frequencies are very lower than the limit and not show in test report.

| | | | |
|-----------|--|----------------------|--------------|
| EUT | BE11000 Ceiling Mount Wi-Fi 7 Access Point | Date of Test | 2024-05-30 |
| Factor | DRH18-E | Temp. / Humidity | 24°C /60% |
| Polarity | Horizontal | Site / Test Engineer | AC2 / You |
| Test Mode | BLE_S8_TX_CH 0 | Test Voltage | AC 120V/60Hz |

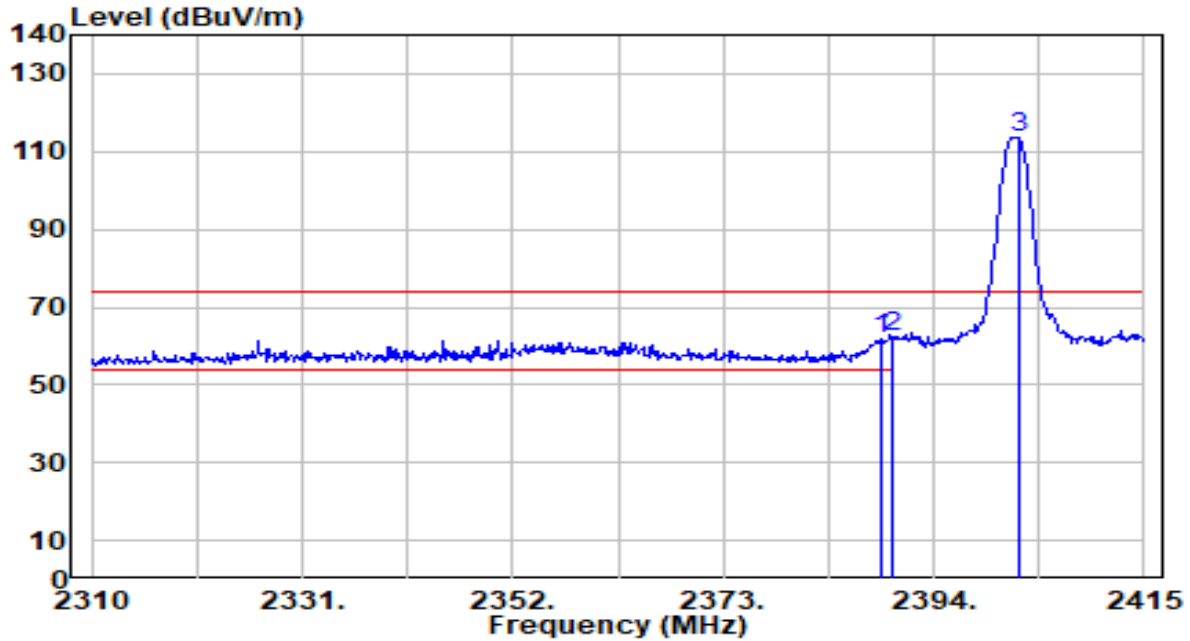

| No | Frequency (MHz) | Reading (dBuV) | C.F (dB/m) | Measurement (dBuV/m) | Margin (dB) | Limit (dBuV/m) | Height (cm) | Angle (deg) | Remark (QP/PK/AV) |
|----|-----------------|----------------|------------|----------------------|-------------|----------------|-------------|-------------|-------------------|
| 1 | 2388.750 | 31.22 | 30.44 | 61.66 | -12.34 | 74.00 | 134 | 130 | Peak |
| 2 | * 2390.000 | 31.72 | 30.45 | 62.16 | -11.84 | 74.00 | 134 | 130 | Peak |
| 3 | 2402.400 | 83.22 | 30.48 | 113.70 | N/A | N/A | 134 | 130 | Peak |

Note:

1. " *", means this data is the worst emission level.
2. C.F (Correction Factor) = Antenna Factor (dB/m) + Cable Loss (dB).
3. Measurement (dBuV/m) = Reading(dBuV) + C.F (Correction Factor).
4. The emission levels of other frequencies are very lower than the limit and not show in test report.

| | | | |
|-----------|--|----------------------|--------------|
| EUT | BE11000 Ceiling Mount Wi-Fi 7 Access Point | Date of Test | 2024-05-29 |
| Factor | DRH18-E | Temp. / Humidity | 24°C /60% |
| Polarity | Horizontal | Site / Test Engineer | AC2 / You |
| Test Mode | BLE_S=8_TX_CH 0 | Test Voltage | AC 120V/60Hz |

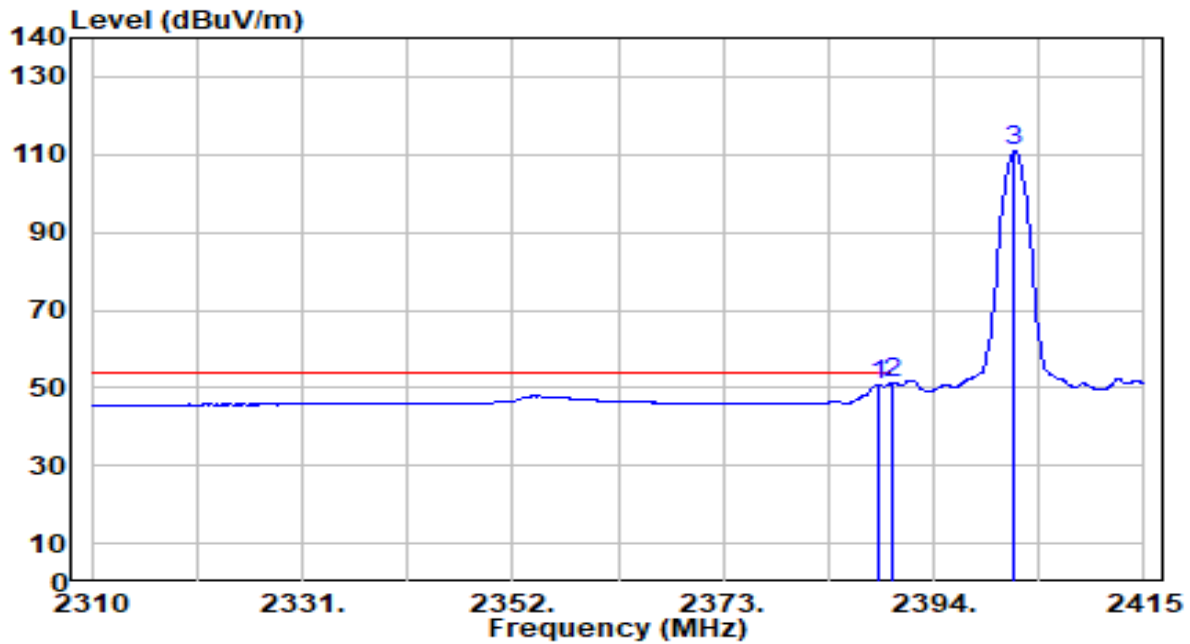

| No | Frequency (MHz) | Reading (dBuV) | C.F (dB/m) | Measurement (dBuV/m) | Margin (dB) | Limit (dBuV/m) | Height (cm) | Angle (deg) | Remark (QP/PK/AV) |
|----|-----------------|----------------|------------|----------------------|-------------|----------------|-------------|-------------|-------------------|
| 1 | 2388.435 | 20.43 | 30.44 | 50.87 | -3.13 | 54.00 | 134 | 130 | Average |
| 2 | * 2390.000 | 21.01 | 30.45 | 51.46 | -2.54 | 54.00 | 134 | 130 | Average |
| 3 | 2402.085 | 80.49 | 30.48 | 110.97 | N/A | N/A | 134 | 130 | Average |

Note:

1. " *", means this data is the worst emission level.
2. C.F (Correction Factor) = Antenna Factor (dB/m) + Cable Loss (dB).
3. Measurement (dBuV/m) = Reading(dBuV) + C.F (Correction Factor).
4. The emission levels of other frequencies are very lower than the limit and not show in test report.

| | | | |
|-----------|--|----------------------|--------------|
| EUT | BE11000 Ceiling Mount Wi-Fi 7 Access Point | Date of Test | 2024-05-29 |
| Factor | DRH18-E | Temp. / Humidity | 24°C /60% |
| Polarity | Vertical | Site / Test Engineer | AC2 / You |
| Test Mode | BLE_S=8_TX_CH 0 | Test Voltage | AC 120V/60Hz |

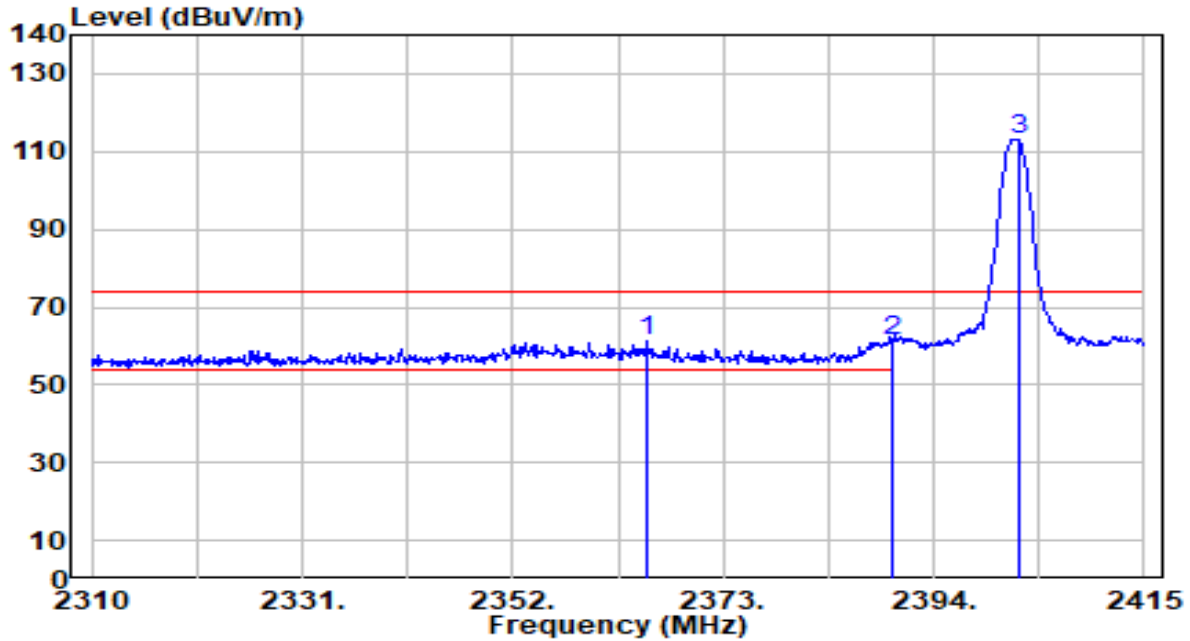

| No | Frequency (MHz) | Reading (dBuV) | C.F (dB/m) | Measurement (dBuV/m) | Margin (dB) | Limit (dBuV/m) | Height (cm) | Angle (deg) | Remark (QP/PK/AV) |
|----|-----------------|----------------|------------|----------------------|-------------|----------------|-------------|-------------|-------------------|
| 1 | 2365.335 | 30.74 | 30.38 | 61.12 | -12.88 | 74.00 | 108 | 163 | Peak |
| 2 | * 2390.000 | 30.85 | 30.45 | 61.30 | -12.70 | 74.00 | 108 | 163 | Peak |
| 3 | 2402.400 | 82.46 | 30.48 | 112.94 | N/A | N/A | 108 | 163 | Peak |

Note:

1. " *", means this data is the worst emission level.
2. C.F (Correction Factor) = Antenna Factor (dB/m) + Cable Loss (dB).
3. Measurement (dBuV/m) = Reading(dBuV) + C.F (Correction Factor).
4. The emission levels of other frequencies are very lower than the limit and not show in test report.

| | | | |
|-----------|--|----------------------|--------------|
| EUT | BE11000 Ceiling Mount Wi-Fi 7 Access Point | Date of Test | 2024-05-29 |
| Factor | DRH18-E | Temp. / Humidity | 24°C /60% |
| Polarity | Vertical | Site / Test Engineer | AC2 / You |
| Test Mode | BLE_S=8_TX_CH 0 | Test Voltage | AC 120V/60Hz |

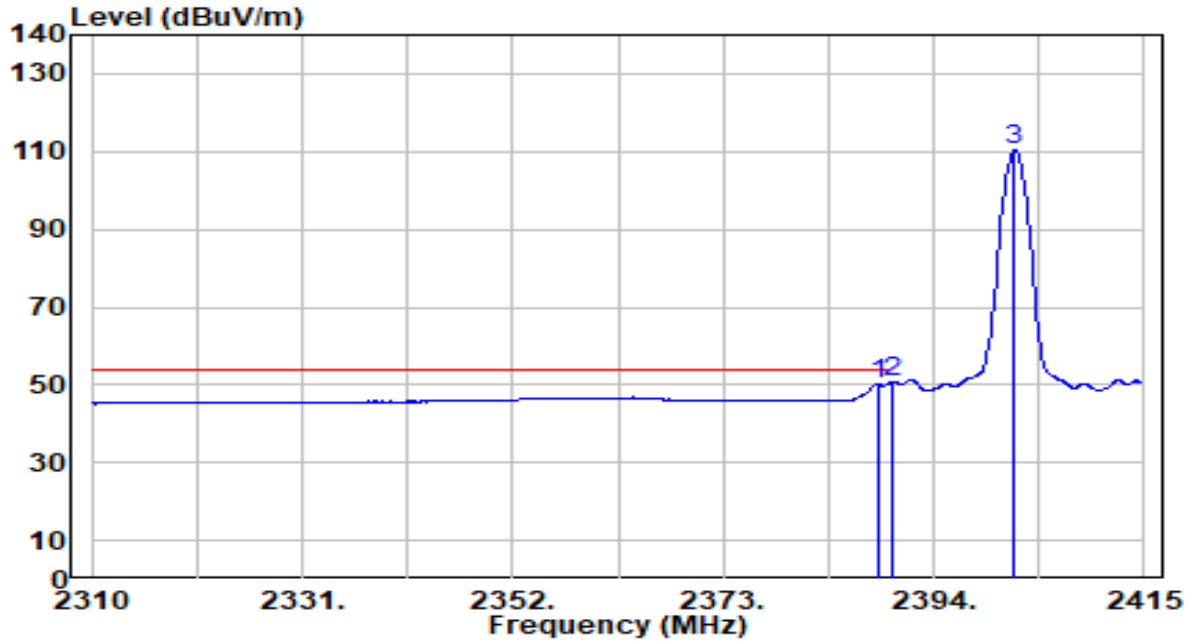

| No | Frequency (MHz) | Reading (dBuV) | C.F (dB/m) | Measurement (dBuV/m) | Margin (dB) | Limit (dBuV/m) | Height (cm) | Angle (deg) | Remark (QP/PK/AV) |
|----|-----------------|----------------|------------|----------------------|-------------|----------------|-------------|-------------|-------------------|
| 1 | 2388.435 | 19.88 | 30.44 | 50.32 | -3.68 | 54.00 | 108 | 163 | Average |
| 2 | * 2390.000 | 20.38 | 30.45 | 50.83 | -3.17 | 54.00 | 108 | 163 | Average |
| 3 | 2402.085 | 79.77 | 30.48 | 110.25 | N/A | N/A | 108 | 163 | Average |

Note:

1. " *", means this data is the worst emission level.
2. C.F (Correction Factor) = Antenna Factor (dB/m) + Cable Loss (dB).
3. Measurement (dBuV/m) = Reading(dBuV) + C.F (Correction Factor).
4. The emission levels of other frequencies are very lower than the limit and not show in test report.

| | | | |
|-----------|--|----------------------|--------------|
| EUT | BE11000 Ceiling Mount Wi-Fi 7 Access Point | Date of Test | 2024-05-29 |
| Factor | DRH18-E | Temp. / Humidity | 24°C /60% |
| Polarity | Horizontal | Site / Test Engineer | AC2 / You |
| Test Mode | BLE_S=8_TX_CH 39 | Test Voltage | AC 120V/60Hz |

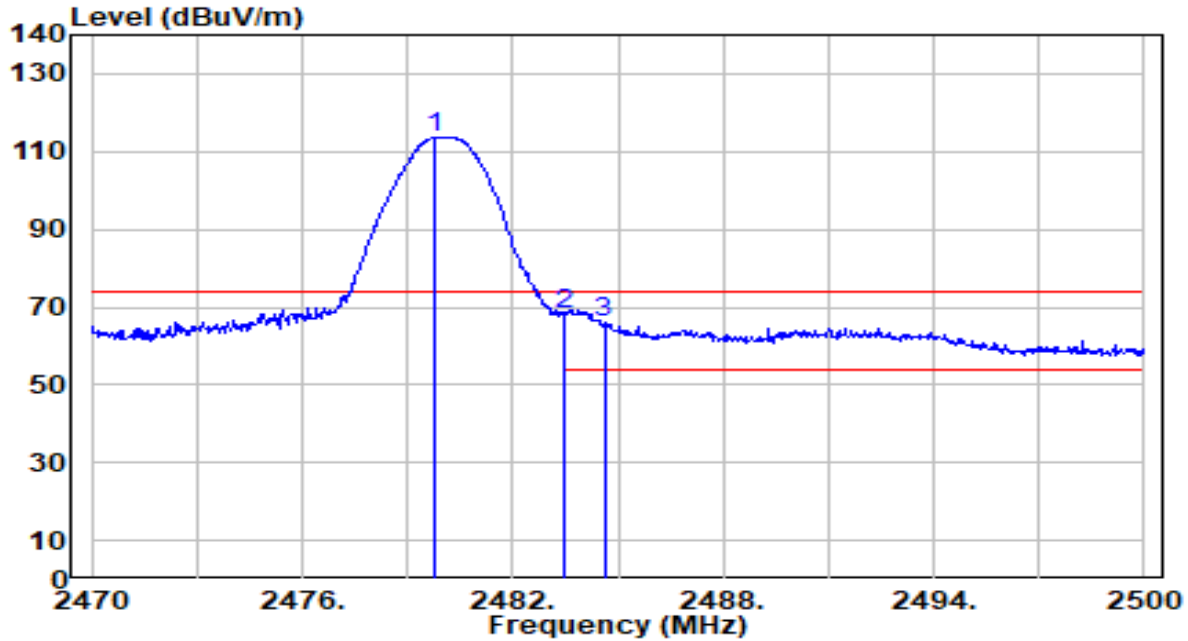

| No | Frequency (MHz) | Reading (dBuV) | C.F (dB/m) | Measurement (dBuV/m) | Margin (dB) | Limit (dBuV/m) | Height (cm) | Angle (deg) | Remark (QP/PK/AV) |
|----|-----------------|----------------|------------|----------------------|-------------|----------------|-------------|-------------|-------------------|
| 1 | 2479.780 | 82.94 | 30.58 | 113.52 | N/A | N/A | 146 | 119 | Peak |
| 2 | * 2483.500 | 37.31 | 30.59 | 67.90 | -6.10 | 74.00 | 146 | 119 | Peak |
| 3 | 2484.610 | 35.39 | 30.59 | 65.98 | -8.02 | 74.00 | 146 | 119 | Peak |

Note:

1. " *", means this data is the worst emission level.
2. C.F (Correction Factor) = Antenna Factor (dB/m) + Cable Loss (dB).
3. Measurement (dBuV/m) = Reading(dBuV) + C.F (Correction Factor).
4. The emission levels of other frequencies are very lower than the limit and not show in test report.

| | | | |
|-----------|--|----------------------|--------------|
| EUT | BE11000 Ceiling Mount Wi-Fi 7 Access Point | Date of Test | 2024-05-29 |
| Factor | DRH18-E | Temp. / Humidity | 24°C /60% |
| Polarity | Horizontal | Site / Test Engineer | AC2 / You |
| Test Mode | BLE_S=8_TX_CH 39 | Test Voltage | AC 120V/60Hz |

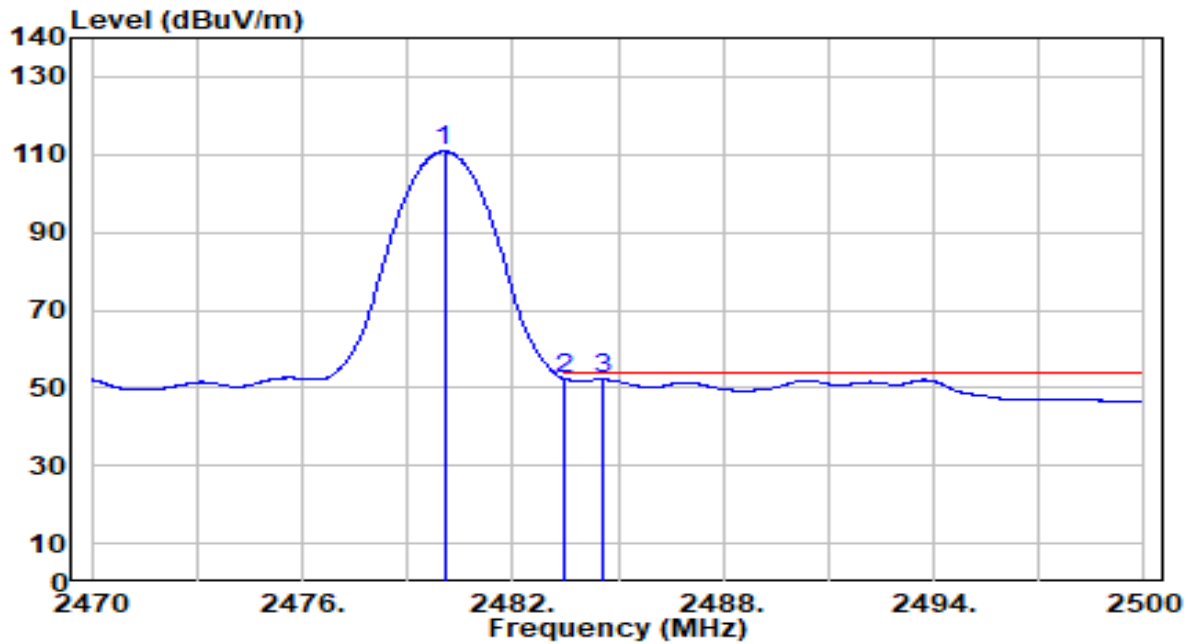

| No | Frequency (MHz) | Reading (dBuV) | C.F (dB/m) | Measurement (dBuV/m) | Margin (dB) | Limit (dBuV/m) | Height (cm) | Angle (deg) | Remark (QP/PK/AV) |
|----|-----------------|----------------|------------|----------------------|-------------|----------------|-------------|-------------|-------------------|
| 1 | 2480.050 | 80.22 | 30.58 | 110.80 | N/A | N/A | 146 | 119 | Average |
| 2 | * 2483.500 | 21.66 | 30.59 | 52.25 | -1.75 | 54.00 | 146 | 119 | Average |
| 3 | 2484.580 | 21.56 | 30.59 | 52.15 | -1.85 | 54.00 | 146 | 119 | Average |

Note:

1. " *", means this data is the worst emission level.
2. C.F (Correction Factor) = Antenna Factor (dB/m) + Cable Loss (dB).
3. Measurement (dBuV/m) = Reading(dBuV) + C.F (Correction Factor).
4. The emission levels of other frequencies are very lower than the limit and not show in test report.

| | | | |
|-----------|--|----------------------|--------------|
| EUT | BE11000 Ceiling Mount Wi-Fi 7 Access Point | Date of Test | 2024-05-29 |
| Factor | DRH18-E | Temp. / Humidity | 24°C /60% |
| Polarity | Vertical | Site / Test Engineer | AC2 / You |
| Test Mode | BLE_S=8_TX_CH 39 | Test Voltage | AC 120V/60Hz |

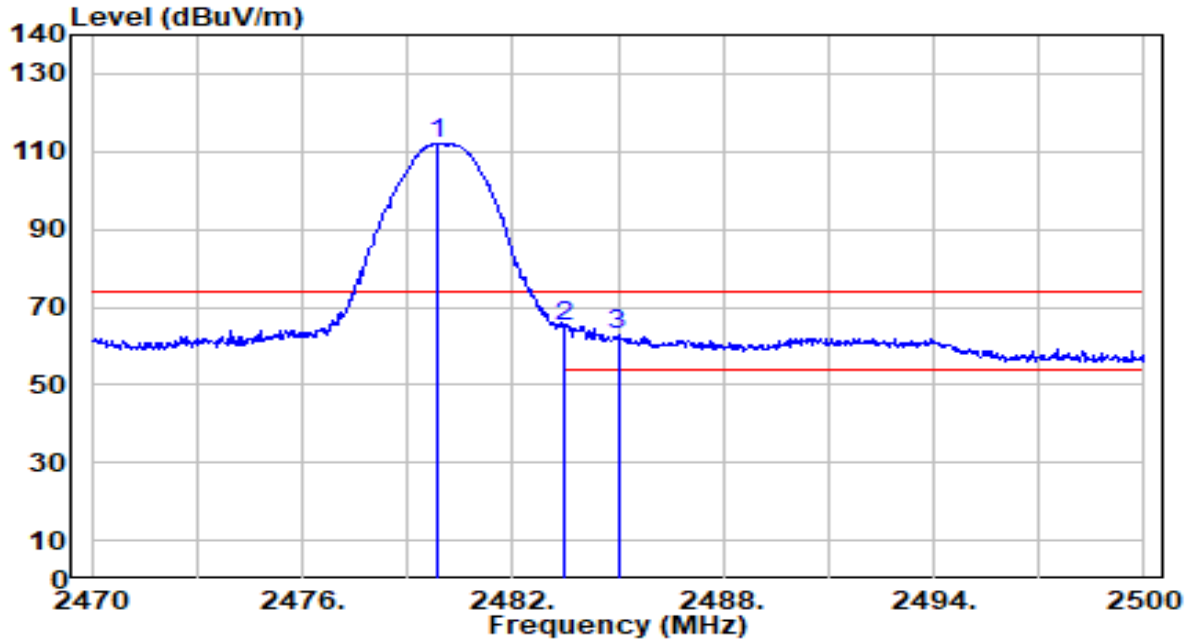

| No | Frequency (MHz) | Reading (dBuV) | C.F (dB/m) | Measurement (dBuV/m) | Margin (dB) | Limit (dBuV/m) | Height (cm) | Angle (deg) | Remark (QP/PK/AV) |
|----|-----------------|----------------|------------|----------------------|-------------|----------------|-------------|-------------|-------------------|
| 1 | 2479.870 | 81.24 | 30.58 | 111.82 | N/A | N/A | 122 | 163 | Peak |
| 2 | * 2483.500 | 34.20 | 30.59 | 64.79 | -9.21 | 74.00 | 122 | 163 | Peak |
| 3 | 2485.000 | 32.50 | 30.59 | 63.09 | -10.91 | 74.00 | 122 | 163 | Peak |

Note:

1. " *", means this data is the worst emission level.
2. C.F (Correction Factor) = Antenna Factor (dB/m) + Cable Loss (dB).
3. Measurement (dBuV/m) = Reading(dBuV) + C.F (Correction Factor).
4. The emission levels of other frequencies are very lower than the limit and not show in test report.

| | | | |
|-----------|--|----------------------|--------------|
| EUT | BE11000 Ceiling Mount Wi-Fi 7 Access Point | Date of Test | 2024-05-29 |
| Factor | DRH18-E | Temp. / Humidity | 24°C /60% |
| Polarity | Vertical | Site / Test Engineer | AC2 / You |
| Test Mode | BLE_S=8_TX_CH 39 | Test Voltage | AC 120V/60Hz |

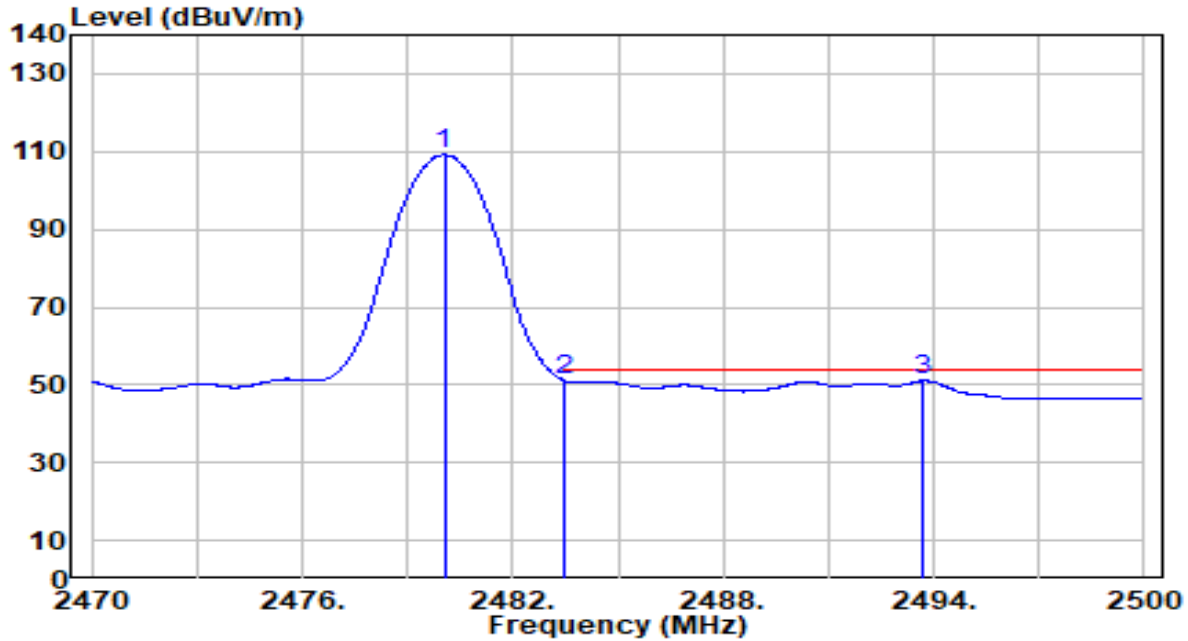

| No | Frequency (MHz) | Reading (dBuV) | C.F (dB/m) | Measurement (dBuV/m) | Margin (dB) | Limit (dBuV/m) | Height (cm) | Angle (deg) | Remark (QP/PK/AV) |
|----|-----------------|----------------|------------|----------------------|-------------|----------------|-------------|-------------|-------------------|
| 1 | 2480.050 | 78.58 | 30.58 | 109.16 | N/A | N/A | 122 | 163 | Average |
| 2 | 2483.500 | 20.41 | 30.59 | 51.00 | -3.00 | 54.00 | 122 | 163 | Average |
| 3 | * 2493.700 | 20.45 | 30.60 | 51.05 | -2.95 | 54.00 | 122 | 163 | Average |

Note:

1. " *", means this data is the worst emission level.
2. C.F (Correction Factor) = Antenna Factor (dB/m) + Cable Loss (dB).
3. Measurement (dBuV/m) = Reading(dBuV) + C.F (Correction Factor).
4. The emission levels of other frequencies are very lower than the limit and not show in test report.

7.8. AC Conducted Emissions Measurement

7.8.1. Test Limit

| FCC Part 15 Subpart C Paragraph 15.207 / RSS-Gen Limits | | |
|---|-----------------|----------------------|
| Frequency (MHz) | QP (dB μ V) | Average (dB μ V) |
| 0.15 - 0.50 | 66 - 56 | 56 - 46 |
| 0.50 - 5.0 | 56 | 46 |
| 5.0 - 30 | 60 | 50 |

Note 1: The lower limit shall apply at the transition frequencies.

Note 2: The limit decreases linearly with the logarithm of the frequency in the range 0.15MHz to 0.5MHz.

7.8.2. Test Setup

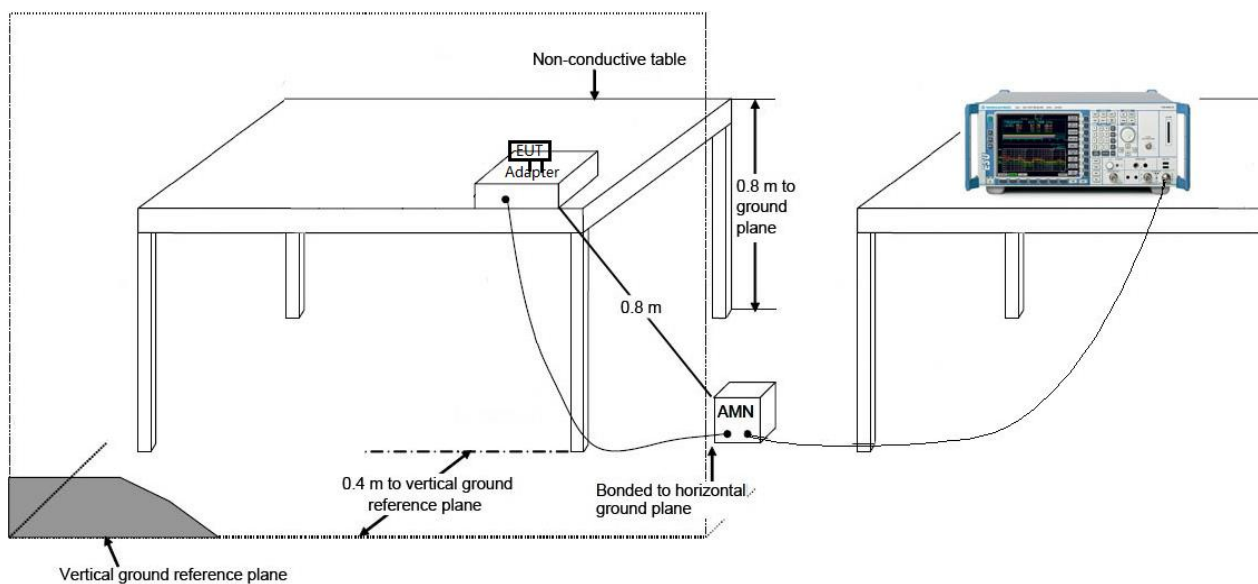

7.8.3. Test Result

| | | | |
|-----------|--|----------------------|--------------|
| EUT | BE11000 Ceiling Mount Wi-Fi 7 Access Point | Date of Test | 2024-07-02 |
| Factor | CE_ENV216-L1 (Filter ON) | Temp. / Humidity | 27.1°C /50% |
| Polarity | Line1 | Site / Test Engineer | SR2 / Will |
| Test Mode | BLE_TX_1Mbps_CH 19 | Test Voltage | AC 120V/60Hz |

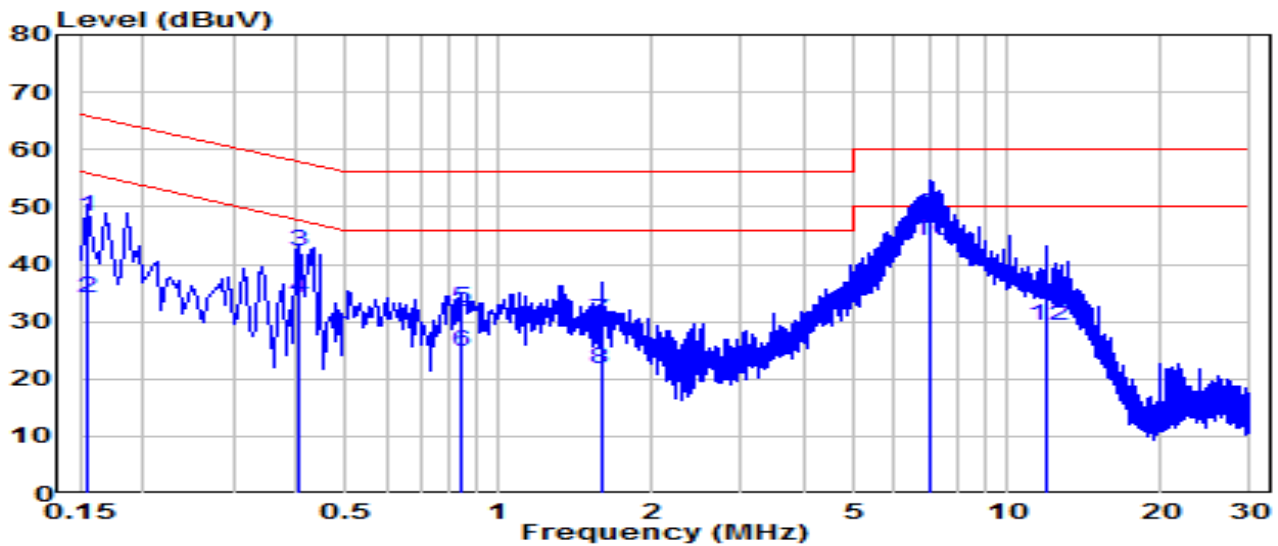

| No | Frequency (MHz) | Reading (dBuV) | C.F (dB) | Measurement (dBuV) | Margin (dB) | Limit (dBuV) | Remark (QP/PK/AV) |
|----|-----------------|----------------|----------|--------------------|-------------|--------------|-------------------|
| 1 | 0.154 | 38.75 | 9.63 | 48.38 | -17.37 | 65.75 | QP |
| 2 | 0.154 | 24.43 | 9.63 | 34.06 | -21.70 | 55.75 | Average |
| 3 | 0.406 | 32.53 | 9.64 | 42.17 | -15.55 | 57.72 | QP |
| 4 | 0.406 | 24.47 | 9.64 | 34.11 | -13.61 | 47.72 | Average |
| 5 | 0.843 | 22.69 | 9.67 | 32.36 | -23.64 | 56.00 | QP |
| 6 | 0.843 | 15.09 | 9.67 | 24.76 | -21.24 | 46.00 | Average |
| 7 | 1.585 | 20.37 | 9.69 | 30.06 | -25.94 | 56.00 | QP |
| 8 | 1.585 | 12.04 | 9.69 | 21.73 | -24.27 | 46.00 | Average |
| 9 | * 7.075 | 38.67 | 9.80 | 48.47 | -11.53 | 60.00 | QP |
| 10 | * 7.075 | 34.16 | 9.80 | 43.96 | -6.04 | 50.00 | Average |
| 11 | 11.979 | 24.23 | 9.88 | 34.11 | -25.89 | 60.00 | QP |
| 12 | 11.979 | 19.46 | 9.88 | 29.34 | -20.66 | 50.00 | Average |

Note:

1. " *", means this data is the worst emission level.
2. C.F (Correction Factor) = LISN Factor (dB)+ Cable Loss (dB).
3. Measurement (dBuV) = Reading(dBuV) + C.F (Correction Factor).

| | | | |
|-----------|--|----------------------|--------------|
| EUT | BE11000 Ceiling Mount Wi-Fi 7 Access Point | Date of Test | 2024-07-02 |
| Factor | CE_ENV216-N (Filter ON) | Temp. / Humidity | 27.1°C /50% |
| Polarity | Neutral | Site / Test Engineer | SR2 / Will |
| Test Mode | BLE_TX_1Mbps_CH 19 | Test Voltage | AC 120V/60Hz |

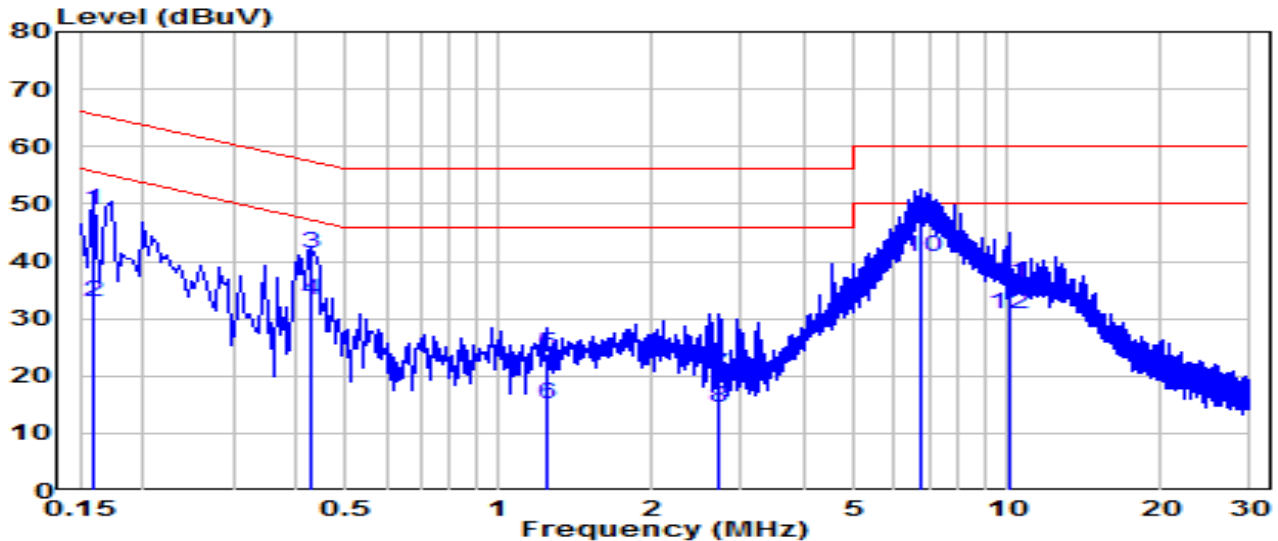

| No | Frequency (MHz) | Reading (dBUV) | C.F (dB) | Measurement (dBUV) | Margin (dB) | Limit (dBUV) | Remark (QP/PK/AV) |
|----|-----------------|----------------|----------|--------------------|-------------|--------------|-------------------|
| 1 | 0.159 | 39.16 | 9.63 | 48.79 | -16.73 | 65.52 | QP |
| 2 | 0.159 | 23.26 | 9.63 | 32.89 | -22.62 | 55.52 | Average |
| 3 | 0.429 | 31.57 | 9.65 | 41.22 | -16.06 | 57.27 | QP |
| 4 | 0.429 | 23.65 | 9.65 | 33.30 | -13.97 | 47.27 | Average |
| 5 | 1.239 | 14.05 | 9.69 | 23.74 | -32.26 | 56.00 | QP |
| 6 | 1.239 | 5.51 | 9.69 | 15.20 | -30.80 | 46.00 | Average |
| 7 | 2.692 | 10.50 | 9.72 | 20.22 | -35.78 | 56.00 | QP |
| 8 | 2.692 | 4.86 | 9.72 | 14.58 | -31.42 | 46.00 | Average |
| 9 | * 6.728 | 36.96 | 9.80 | 46.76 | -13.24 | 60.00 | QP |
| 10 | * 6.728 | 30.82 | 9.80 | 40.62 | -9.38 | 50.00 | Average |
| 11 | 10.040 | 26.28 | 9.89 | 36.17 | -23.83 | 60.00 | QP |
| 12 | 10.040 | 20.98 | 9.89 | 30.87 | -19.13 | 50.00 | Average |

Note:

1. " *", means this data is the worst emission level.
2. C.F (Correction Factor) = LISN Factor (dB)+ Cable Loss (dB).
3. Measurement (dBUV) = Reading(dBUV) + C.F (Correction Factor).

| | | | |
|-----------|--|----------------------|--------------|
| EUT | BE11000 Ceiling Mount Wi-Fi 7 Access Point | Date of Test | 2024-07-02 |
| Factor | CE_ENV216-L1 (Filter ON) | Temp. / Humidity | 27.1°C /50% |
| Polarity | Line1 | Site / Test Engineer | SR2 / Will |
| Test Mode | BLE_TX_1Mbps_CH 19 | Test Voltage | AC 240V/60Hz |

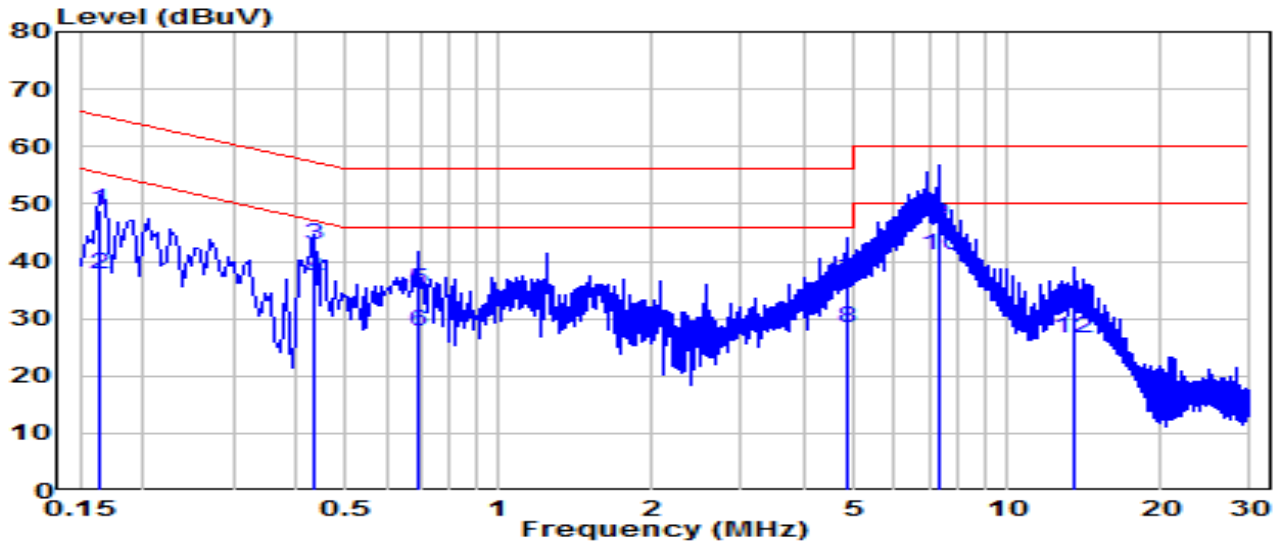

| No | Frequency (MHz) | Reading (dBuV) | C.F (dB) | Measurement (dBuV) | Margin (dB) | Limit (dBuV) | Remark (QP/PK/AV) |
|----|-----------------|----------------|----------|--------------------|-------------|--------------|-------------------|
| 1 | 0.163 | 39.39 | 9.63 | 49.03 | -16.26 | 65.28 | QP |
| 2 | 0.163 | 28.13 | 9.63 | 37.76 | -17.52 | 55.28 | Average |
| 3 | 0.433 | 33.23 | 9.65 | 42.88 | -14.31 | 57.19 | QP |
| 4 | 0.433 | 27.30 | 9.65 | 36.95 | -10.24 | 47.19 | Average |
| 5 | 0.690 | 25.44 | 9.66 | 35.10 | -20.90 | 56.00 | QP |
| 6 | 0.690 | 18.19 | 9.66 | 27.85 | -18.15 | 46.00 | Average |
| 7 | 4.821 | 26.72 | 9.74 | 36.46 | -19.54 | 56.00 | QP |
| 8 | 4.821 | 18.74 | 9.74 | 28.48 | -17.52 | 46.00 | Average |
| 9 | * 7.340 | 36.69 | 9.80 | 46.49 | -13.51 | 60.00 | QP |
| 10 | * 7.340 | 31.18 | 9.80 | 40.98 | -9.02 | 50.00 | Average |
| 11 | 13.451 | 22.03 | 9.89 | 31.92 | -28.08 | 60.00 | QP |
| 12 | 13.451 | 16.61 | 9.89 | 26.50 | -23.50 | 50.00 | Average |

Note:

1. " *", means this data is the worst emission level.
2. C.F (Correction Factor) = LISN Factor (dB)+ Cable Loss (dB).
3. Measurement (dBuV) = Reading(dBuV) + C.F (Correction Factor).

| | | | |
|-----------|--|----------------------|--------------|
| EUT | BE11000 Ceiling Mount Wi-Fi 7 Access Point | Date of Test | 2024-07-02 |
| Factor | CE_ENV216-N (Filter ON) | Temp. / Humidity | 27.1°C /50% |
| Polarity | Neutral | Site / Test Engineer | SR2 / Will |
| Test Mode | BLE_TX_1Mbps_CH 19 | Test Voltage | AC 240V/60Hz |

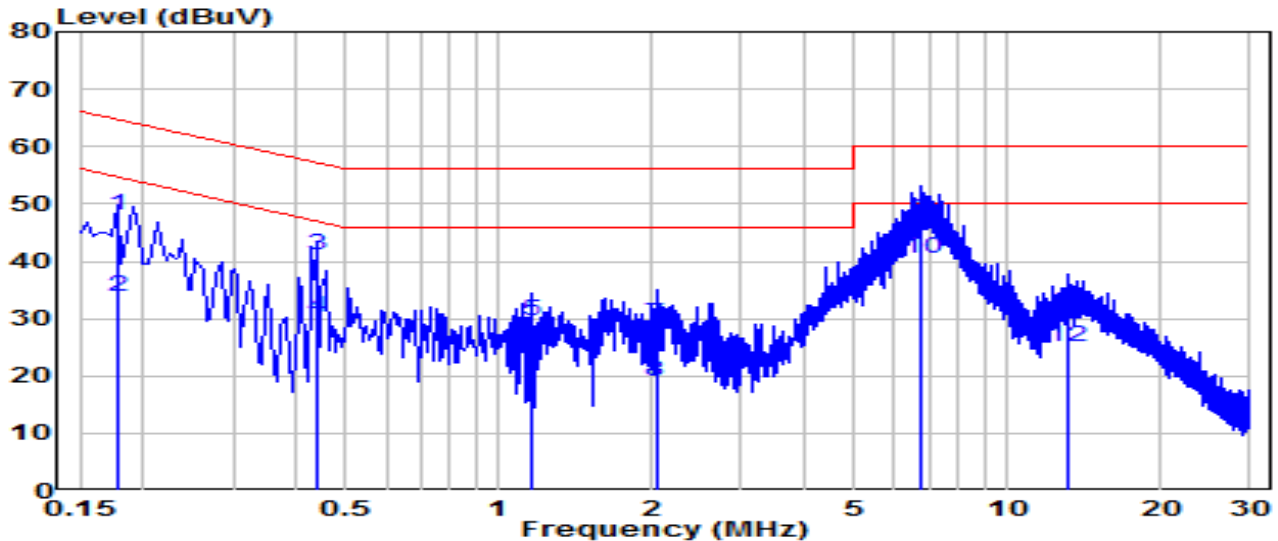

| No | Frequency (MHz) | Reading (dBuV) | C.F (dB) | Measurement (dBuV) | Margin (dB) | Limit (dBuV) | Remark (QP/PK/AV) |
|----|-----------------|----------------|----------|--------------------|-------------|--------------|-------------------|
| 1 | 0.177 | 38.31 | 9.63 | 47.94 | -16.69 | 64.63 | QP |
| 2 | 0.177 | 24.27 | 9.63 | 33.91 | -20.72 | 54.63 | Average |
| 3 | 0.438 | 31.56 | 9.65 | 41.21 | -15.89 | 57.10 | QP |
| 4 | 0.438 | 20.54 | 9.65 | 30.19 | -16.91 | 47.10 | Average |
| 5 | 1.162 | 19.83 | 9.68 | 29.52 | -26.48 | 56.00 | QP |
| 6 | 1.162 | 13.28 | 9.68 | 22.97 | -23.03 | 46.00 | Average |
| 7 | 2.035 | 19.15 | 9.71 | 28.86 | -27.14 | 56.00 | QP |
| 8 | 2.035 | 9.25 | 9.71 | 18.96 | -27.04 | 46.00 | Average |
| 9 | * 6.760 | 37.21 | 9.80 | 47.02 | -12.98 | 60.00 | QP |
| 10 | * 6.760 | 30.54 | 9.80 | 40.35 | -9.65 | 50.00 | Average |
| 11 | 13.073 | 21.26 | 9.92 | 31.18 | -28.82 | 60.00 | QP |
| 12 | 13.073 | 15.20 | 9.92 | 25.12 | -24.88 | 50.00 | Average |

Note:

- "*", means this data is the worst emission level.
- C.F (Correction Factor) = LISN Factor (dB)+ Cable Loss (dB).
- Measurement (dBuV) = Reading(dBuV) + C.F (Correction Factor).

8. CONCLUSION

The data collected relate only the item(s) tested and show that the **BE11000 Ceiling Mount Wi-Fi 7 Access Point** is in compliance with Part 15C of the FCC Rules.

Appendix A : Test Photograph

Refer to “2405TW0113-UT” file.

Appendix B : External Photograph

Refer to “2405TW0113-UE” file.

Appendix C : Internal Photograph

Refer to “2405TW0113-UI” file.

————— The End —————