

# TP-LINK CORPORATION PTE.LTD.

Federal Communications Commission  
 7435 Oakland Mills Road  
 Columbia MD 21046

American Certification Body, Inc.  
 6731 Whittier Avenue  
 Suite C110  
 McLean, VA 22101

Subject: Requesting Class II permissive change for FCC ID: 2BCGWBE230

To Whom It May Concern:

The purpose of this letter is to request a Class II Permissive change for FCC ID: 2BCGWBE230, original granted on 04/26/2024.

There is no other hardware or electrical modification made to the applying transmitter itself except below:

1. Change the signal transformer of the network port.(Update transformer model number.)

The model of transformer T3,T4 & T1 has been updated to HST24500SCR & HST-36001DAR.

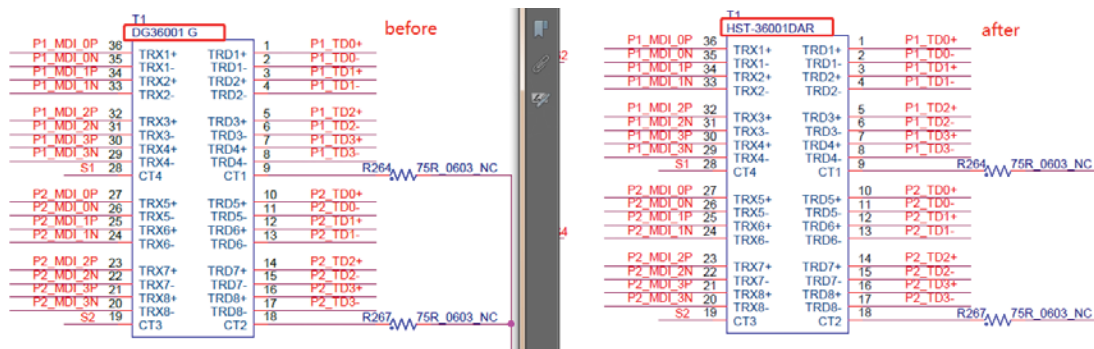
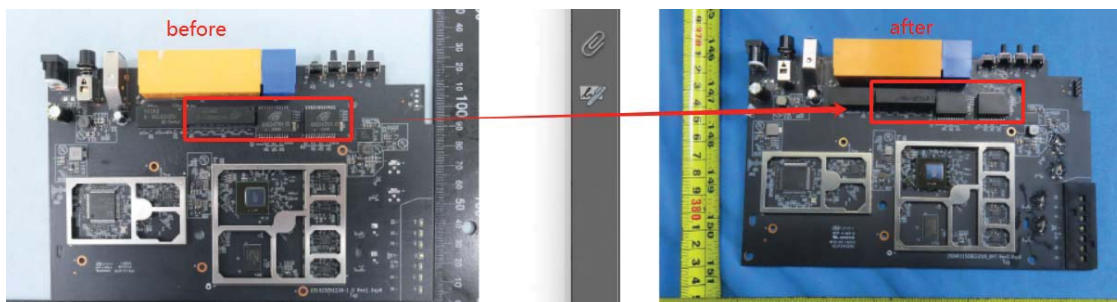

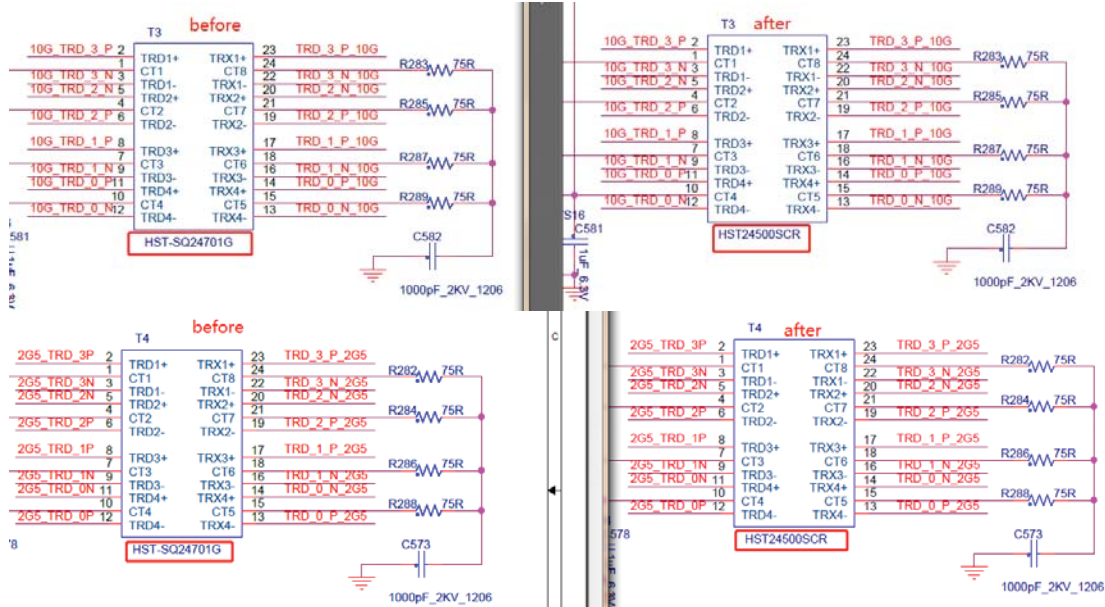

This C2PC is compliance with 4 items in KDB 178919 D01v06 section III. D.

- 1) The new chip component is pin-for-pin compatible.
- 2) The new chip has the same basic function as the old chip, from an external perspective (internal circuitry may differ).
- 3) No change in radio parameters has occurred.
- 4) The same conditions apply when a small area (approximately the same area as the chip) of the PCB is replaced with an equivalent chip.

Please contact me if you have any questions or need further information regarding this application.

Best Regards,

Name: Sarah Wang

Funtion: Regulatory Compliance Manager

Date: 2024-05-29

Signed : *Sarah Wang*