

## 深圳市中投智能科技有限公司

## 承 認 書

## SPECIFICATION FOR APPROVAL

客 戶: CUSTOMER:	
客 戶 料 號: CUST P/N:	SP0611
公 司 料 號: FINE P/N:	A11 线圈 50*10TS*6.5UH
產 品 型 號: DESC:	SP0611
日 期: DATE:	2023/10/18
版 本: Version:	A.0

擬制 PREPARED BY	審核 CHECKED BY	批准 APPROVED BY	客戶承認 CUSTOMER APPROVE

Manufacturer: Shenzhen CIC Intelligent Technology Co., Ltd.  
Address: Room 1203B, Block A, Fencheng Zhigu Building, No.60 Tiezai Road, Gongle Community  
, xixiang street, Baoan District, Shenzhen.



## SPECIFICATION

產品型號: DESC	50*10TS*6.5UH	版本 Rev: A.0	客戶 CUST: 客戶料号 CUST P/N:
---------------	---------------	----------------	----------------------------

一、尺寸 DIMENSION:(mm)

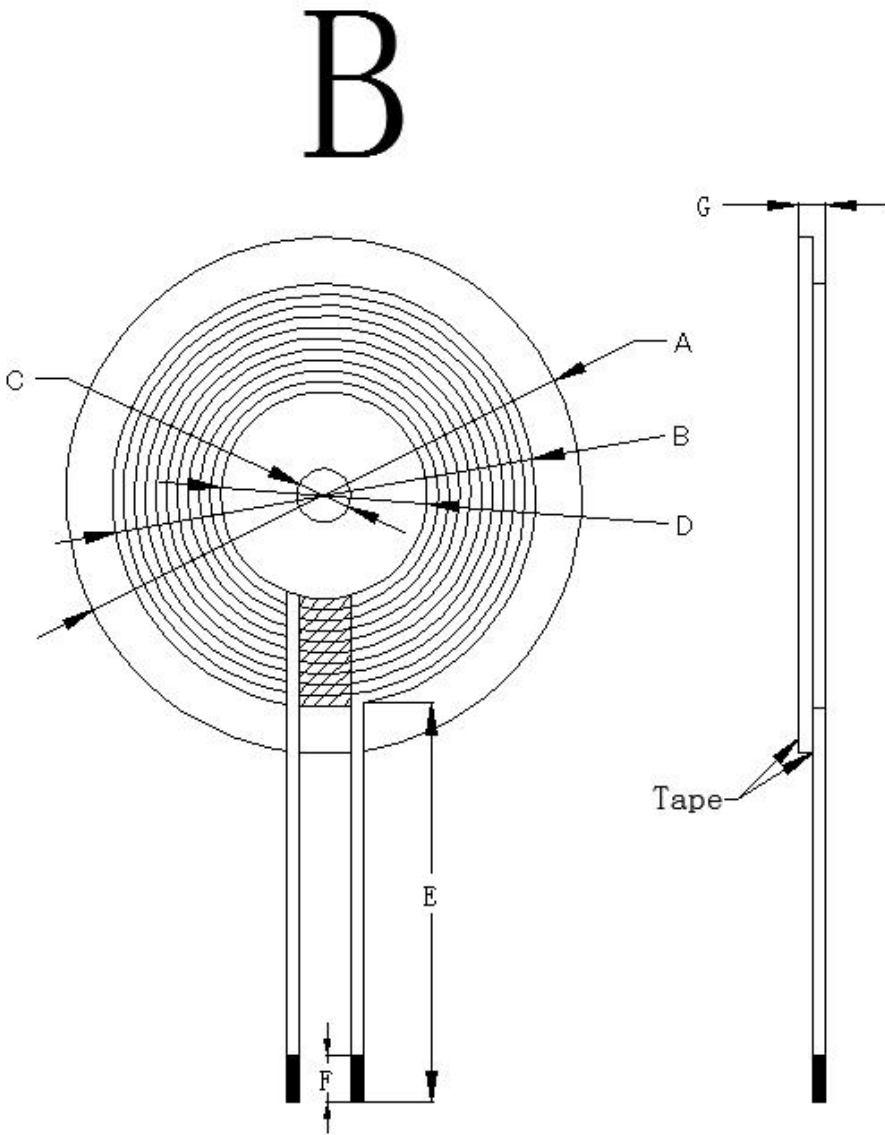

A	50±1
B	40±1
C	5.2±0.5
D	20±1
E	40±2
F	3±2
G	2.2±0.2
H	
I	
K	

注：

- 1.交叉出线;
- 2.线圈贴有孔圆磁片，开槽，磁片尺寸 50±1mm,厚度为 0.8±0.1mm.
- 3.磁片加线圈整体厚度 2.2±0.2MM

二、原理图 SCHEMATIC DIAGRAM:

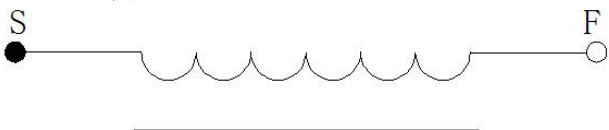

三、绕线参数 Winding Specification:

序号 NO.	端子 TERMINAL		线径 WIRE	圈数 Turns	绕线方向 Winding Direction
1	S	F	丝包线 100P	10Ts	CCW

四、电气特性 ELECTRICAL CHARACTERISTICS:

温度 TEMPERATURE:25±10°C, 湿度 RELATIVE HUMIDITY:65±20%

序号 NO.	项目 ITEM	端子 TERMINAL	标准 SPECIFICATION	测试条件 TEST FREQUENCY	测试仪器 TEST EQUIPMENTS
1	IND.	S-F	3.8uH ±10%单独线圈	100KHz/1.0V	LCZ METER 1062B
2	IND.	S-F	6.5H ±10%加磁片	100KHz/1.0V	LCZ METER 1062B
3	DCR	S-F	≤50m Ω		LCZ METER 502B

拟制/日期 PREPARED BY/DATE	审核/日期 CHECKED BY/DATE
易立存 2023.10.18	