

## 深圳市中投智能科技有限公司

## 承 認 書

## SPECIFICATION FOR APPROVAL

客 戶:  
CUSTOMER:客 戶 料 號:  
CUST P/N:

SP0610

公 司 料 號:  
FINE P/N:

A11 线圈 50\*10TS\*6.5UH

產 品 型 號:  
DESC:

SP0610

日 期:  
DATE:

2022/10/18

版 本:  
Version:

A.0

擬制 PREPARED BY	審核 CHECKED BY	批准 APPROVED BY	客戶承認 CUSTOMER APPROVE

Manufacturer: Shenzhen CIC Intelligent Technology Co., Ltd.

Address: Room 1203B, Block A, Fencheng Zhigu Building, No.60 Tiezai Road, Gongle Community, xixiang street, Baoan District, Shenzhen.



# SPECIFICATION

產品型號: DESC	<b>50*10TS*6.5UH</b>	版本 Rev: A.0	客戶 CUST: 客戶料号 CUST P/N:	
---------------	----------------------	----------------	----------------------------	--

一、尺寸 DIMENSION:(mm)

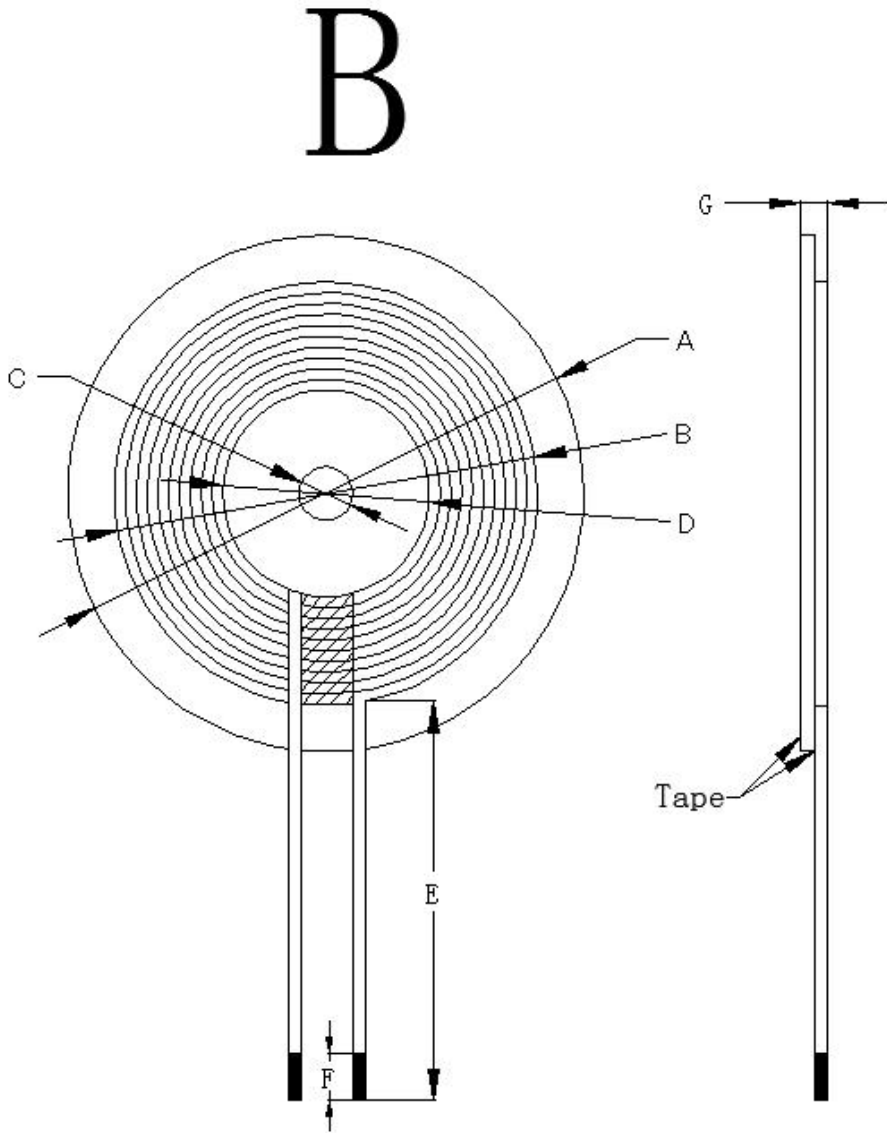

A	50±1
B	40±1
C	5.2±0.5
D	20±1
E	13±2
F	3±2
G	2.4±0.2
H	
I	
K	

注:  
 1.交叉出线;  
 2.线圈贴有孔圆磁片, 开槽, 磁片尺寸 50±1mm,厚度为 0.9±0.15mm.  
 3.磁片加线圈整体厚度 2.4±0.2MM

二、原理图 SCHEMATIC DIAGRAM:

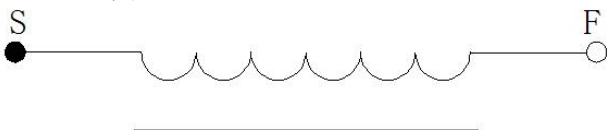

## 三、绕线参数 Winding Specification:

序号 NO.	端子 TERMINAL		线径 WIRE	圈数 Turns	绕线方向 Winding Direction
1	S	F	丝包线 0.08*105P	10Ts	CCW

## 四、电气特性 ELECTRICAL CHARACTERISTICS:

温度 TEMPERATURE:25±10°C, 湿度 RELATIVE HUMIDITY:65±20%

序号 NO.	项目 ITEM	端子 TERMINAL	标准 SPECIFICATION	测试条件 TEST FREQUENCY	测试仪器 TEST EQUIPMENTS
1	IND.	S-F	3.8uH ±10%单独线圈	100KHz/1.0V	LCZ METER 1062B
2	IND.	S-F	6.5H ±10%加磁片	100KHz/1.0V	LCZ METER 1062B
3	DCR	S-F	≤50mΩ		LCZ METER 502B

拟制/日期 PREPARED BY/DATE

审核/日期 CHECKED BY/DATE

周华响2022.10.18