

# LIBERTY DEFENSE TECHNOLOGIES, INC.

## TEST REPORT

**SCOPE OF WORK**

EMISSIONS TESTING – HEXWAVE SECURITY BODY SCANNER

**REPORT NUMBER**

105270120BOX-007\_R1

**ISSUE DATE**

08/11/2023

**[REVISED DATE]**

10/25/2023

**DOCUMENT CONTROL NUMBER**

Generic EMC Report Shell Rev. October 2022  
© 2022 INTERTEK



## EMISSIONS TEST REPORT (FULL COMPLIANCE)

**Report Number:** 105270120BOX-007

**Project Number:** G105270120

**Report Issue Date:** 08/11/2023

**Report Revision Date:** 10/25/2023

**Model(s) Tested:** HW2000

**Model(s) Partially Tested:** None

**Model(s) Not Tested but declared equivalent by the client:** None

**Standards:** CFR 47 FCC Part 15, Subpart F, §15.511 (08/2023)  
FCC Waver DA-22-133A1-c3  
RSS-220 Issue 1 Amendment 1, July 2018  
RSS-GEN Issue 5 April 2018

Tested by:  
Intertek Testing Services  
70 Codman Hill Road  
Boxborough, MA 01719  
USA

Client:  
Liberty Defense Technologies, Inc.  
187 Ballardvale St, Suite 110  
Wilmington, MA 01887  
USA

Report prepared by:

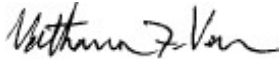

Vathana Ven / Sr. EMC Staff Engineer

Report reviewed by:



Kouma Sinn / Sr. EMC Staff Engineer

*This report is for the exclusive use of Intertek's Client and is provided pursuant to the agreement between Intertek and its Client. Intertek's responsibility and liability are limited to the terms and conditions of the agreement. Intertek assumes no liability to any party, other than to the Client in accordance with the agreement, for any loss, expense or damage occasioned by the use of this report. Only the Client is authorized to permit copying or distribution of this report and then only in its entirety. Any use of the Intertek name or one of its marks for the sale or advertisement of the tested material, product or service must first be approved in writing by Intertek. The observations and test results in this report are relevant only to the sample tested. This report by itself does not imply that the material, product, or service is or has ever been under an Intertek certification program.*

Table of Contents

**1 Introduction and Conclusion..... 4**

**2 Test Summary ..... 4**

**3 Client Information ..... 5**

**4 Description of Equipment Under Test and Variant Models..... 5**

**5 System Setup and Method ..... 6**

**6 Maximum EIRP ..... 7**

**7 Occupied Bandwidth ..... 12**

**8 Total Transmit Time..... 15**

**9 Unwanted Emissions..... 18**

**10 AC Mains Conducted Emissions ..... 40**

**11 Appendix A - FCC Waiver DA-22-133A1-c3 ..... 45**

**12 Revision History..... 62**

**1 Introduction and Conclusion**

The tests indicated in section 2.0 were performed on the product constructed as described in section 4.0. The remaining test sections are the verbatim text from the actual data sheets used during the investigation. These test sections include the test name, the specified test Method, a list of the actual Test Equipment Used, documentation Photos, Results and raw Data. No additions, deviations, or exclusions have been made from the standard(s) unless specifically noted.

Based on the results of our investigation, we have concluded the product tested **complies** with the requirements of the standard(s) indicated. The results obtained in this test report pertain only to the item(s) tested. Intertek does not make any claims of compliance for samples or variants which were not tested.

**2 Test Summary**

Section	Test full name	Result
3	Client Information	--
4	Description of Equipment Under Test and Variant Models	--
5	System Setup and Method	--
6	Fundamental Emissions CFR 47 FCC Part 15, Subpart F, §15.511 (08/2023), FCC Waver DA-22-133A1-c3 RSS-220 Issue 1 Amendment 1, July 2018	Pass
7	Operational Bandwidth CFR 47 FCC Part 15, Subpart F, §15.511 (08/2023), FCC Waver DA-22-133A1-c3 RSS-220 Issue 1 Amendment 1, July 2018	Pass
8	Total Transmit Time CFR 47 FCC Part 15, Subpart F, §15.511 (08/2023), FCC Waver DA-22-133A1-c3 RSS-220 Issue 1 Amendment 1, July 2018	Pass
9	Unwanted Emissions CFR 47 FCC Part 15C, 15.209(c) (08/2023) RSS-220 Issue 1 Amendment 1, July 2018	Pass
10	AC Mains Conducted Emissions CFR 47 FCC Part 15C, 15.207(a) (08/2023) RSS-GEN Issue 5 April 2018	Pass
11	Appendix A - FCC Waiver	--
12	Appendix B – Mixer/Horn Calibration Certificates	--
13	Revision History	--

**3 Client Information**

**This EUT was tested at the request of:**

**Client:** Liberty Defense Technologies, Inc.  
187 Ballardvale St, Suite 110  
Wilmington, MA 01887  
USA

**Contact:** Val Safran  
**Telephone:** 888-617-7226  
**Email:** [vsafra@libertydefense.com](mailto:vsafra@libertydefense.com)

**4 Description of Equipment Under Test and Variant Models**

**Manufacturer:** Liberty Defense Technologies, Inc.  
187 Ballardvale St, Suite 110  
Wilmington, MA 01887  
USA

Equipment Under Test			
Description	Manufacturer	Model Number	Serial Number
SECURITY DETECTION	Liberty Defense	Hexware – HW2000	HW-05003

Receive Date:	06/26/2023, 07/13/2023
Received Condition:	Good
Type:	Production

Description of Equipment Under Test (provided by client)
HEXWAVE screens for concealed metallic and non-metallic weapons and other threats using millimeter wave, advanced 3D imaging, and Artificial Intelligence for enhanced security. The system can process people seamlessly in all types of venues both indoor and outdoor.

Equipment Under Test Power Configuration			
Rated Voltage	Rated Current	Rated Frequency	Number of Phases
100-264 VAC	15 A	50/60 Hz	1

**Operating modes of the EUT:**

No.	Descriptions of EUT Exercising
1	Transmitter frequency sweep active

**Software used by the EUT:**

No.	Descriptions of EUT Exercising
1	Linux revision 18

Radio/Receiver Characteristics	
Frequency Band(s)	6-10.6 GHz
Modulation Type(s)	Chirp
Maximum EIRP	-47.07 dBm
Test Channels	Sweep Ranges: 6-10.6 GHz
Occupied Bandwidth	4.571 GHz
Equipment Type	6-10.6 GHz Radio in a host
Antenna Type and Gain	Integral antenna, +4 dBi

**Variant Models:**

The following variant models were not tested as part of this evaluation, but have been identified by the manufacturer as being electrically identical models, depopulated models, or with reasonable similarity to the model(s) tested. Intertek does not make any claims of compliance for samples or variants which were not tested.

None

**5 System Setup and Method**

Cables					
ID	Description	Length (m)	Shielding	Ferrites	Termination
1	AC Mains	2	None	None	AC Mains
2	Ethernet cable	3	None	None	Router
3	Ethernet cable	3	None	None	Tablet

Support Equipment			
Description	Manufacturer	Model Number	Serial Number
Ethernet router	MikroTik	RB962UiGS-5HacT2HnT-US	CC500FFFD350/226/USr2
AC adapter	Cull Power	SAW30-240-1200U	Not labeled
Galaxy Tab S7 FE	Samsung	SM-T733	R52RB0KGCJR

**5.1 Method:**

Configuration as required by ANSI C63.10:2013, ANSI C63.4:2014, RSS-220 Issue 1 Amendment 1, July 2018, RSS-GEN Issue 5 April 2018, and FCC Waver DA06-1589.

**5.2 EUT Block Diagram:**

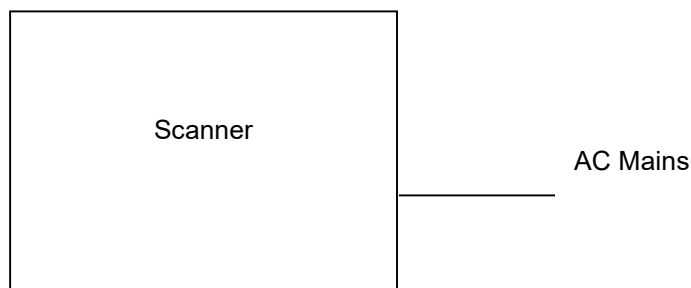

## 6 Maximum EIRP

### 6.1 Method

Tests are performed in accordance with ANSI C63.10 and FCC Waver DA-22-133A1-c3.

**TEST SITE:** 10m ALSE

**The 10m ALSE** is 13m (Length) x 21m (Depth) x 10m (Height) with the effective size in terms of space from the tips of the absorber is 12m (Length) x 20m (Depth) x 8.5m (Height). This chamber achieves broadband performance using a unique arrangement of hybrid and ferrite tile absorber. This chamber has a built in 3m diameter turntable (Embedded type). The metal structure of the table makes electrical connection around the entire circumference of the turntable to the ground plane with a metal brush type connection. The turntable is located on one end of the chamber and the antennas are mounted 3 and 10 meters away at the other end of the chamber on the adjustable an Antenna Mast. The antenna mast is a non-conductive bore sighted type with remote control of antenna height and polarization. The Antenna Mast and the turntable can be remotely controlled through the controller located in the adjacent Control room. A Styrofoam table 80 cm high is used for table-top equipment.

#### Measurement Uncertainty

Measurement	Frequency Range	Expanded Uncertainty (k=2)	Ucispr
Radiated Emissions, 10m	30-1000 MHz	5.6 dB	6.3 dB
Radiated Emissions, 3m	30-1000 MHz	4.9 dB	6.3 dB
Radiated Emissions, 3m	1-6 GHz	4.4 dB	5.2 dB
Radiated Emissions, 3m	6-15 GHz	4.9 dB	5.5 dB
Radiated Emissions, 3m	15-18 GHz	4.6 dB	5.5 dB
Radiated Emissions, 3m	18-40 GHz	4.6 dB	N/A

As shown in the table above our radiated emissions  $U_{lab}$  is less than the corresponding  $U_{CISPR}$  reference value in CISPR 16-4-2 Table 1, hence the compliance of the product is only based on the measured value, and no measurement uncertainty correction is required, based on CISPR 22 and CISPR 11 (for 2006 and later revisions) Clause 11.

#### **Sample Calculation**

The field strength is calculated by adding the Antenna Factor and Cable Factor, and subtracting the Amplifier Gain (if any) from the measured reading. The basic equation with a sample calculation is as follows:

$$FS = RA + AF + CF - AG$$

Where

- FS = Field Strength in dB $\mu$ V/m
- RA = Receiver Amplitude (including preamplifier) in dB $\mu$ V
- CF = Cable Attenuation Factor in dB
- AF = Antenna Factor in dB
- AG = Amplifier Gain in dB

In the following table(s), the reading shown on the data table reflects the preamplifier gain. An example for the calculations in the following table is as follows.

Assume a receiver reading of 52.0 dB $\mu$ V is obtained. The antenna factor of 7.4 dB and cable factor of 1.6 dB is added. The amplifier gain of 29 dB is subtracted, giving a field strength of 32 dB $\mu$ V/m. This value in dB $\mu$ V/m was converted to its corresponding level in  $\mu$ V/m.

RA = 52.0 dB $\mu$ V  
AF = 7.4 dB/m  
CF = 1.6 dB  
AG = 29.0 dB  
FS = 32 dB $\mu$ V/m

To convert from dB $\mu$ V to  $\mu$ V or mV the following was used:

$UF = 10^{(NF / 20)}$  where UF = Net Reading in  $\mu$ V  
NF = Net Reading in dB $\mu$ V

**Example:**

$FS = RA + AF + CF - AG = 52.0 + 7.4 + 1.6 - 29.0 = 32.0$   
 $UF = 10^{(32 \text{ dB}\mu\text{V} / 20)} = 39.8 \mu\text{V/m}$

Alternately, when BAT-EMC Emission Software is used, the “Level” includes all losses and gains and is compared directly in the “Margin” column to the “Limit”. The “Correction” includes Antenna Factor, Preamp, and Cable Loss. These are already accounted for in the “Level” column.



**6.2 Test Equipment Used:**

Asset	Description	Manufacturer	Model	Serial	Cal Date	Cal Due
DAV006'	Weather Station	Davis	6250	MS191218071	02/21/2023	02/21/2024
EMC04'	ANTENNA, RIDGED GUIDE, 18-40 GHZ	EMCO	3116	2090	01/26/2023	01/26/2024
CBLHF2012-5M-2'	5m 9kHz-40GHz Coaxial Cable - SET2	Huber & Suhner	SF102	252676002	02/25/2023	02/25/2024
CBLHF2012-2M-2'	2m 9kHz-40GHz Coaxial Cable - SET2	Huber & Suhner	SF102	252675002	02/18/2023	02/18/2024
ROS005-1'	Signal and Spectrum Analyzer	Rohde and Shwartz	FSW43	100646	11/18/2022	11/18/2023
PRE9'	100MHz-40GHz Preamp	MITEQ	NSP4000-NFG	1260417	09/23/2022	09/23/2023

**Software Utilized:**

Name	Manufacturer	Version
None		

**6.3 Results:**

The sample tested was found to Comply.

Fundamental emissions Limits (FCC Part 15, Subpart F, §15.511, FCC Waver DA-22-133A1-c3):

(c) The radiated emissions at or below 960 MHz from a device operating under the provisions of this section shall not exceed the emission levels in § 15.209. The radiated emissions above 960 MHz from a device operating under the provisions of this section shall not exceed the following average limits when measured using a resolution bandwidth of 1 MHz:

Band	Frequency in MHz	EIRP in dBm
960-1610		-53.3
1610-1990		-51.3
1990-10600		-41.3
Above 10600		-51.3

Fundamental emissions Limits (RSS-220, FCC Waver DA-22-133A1-c3):

(d) Radiated emissions above 960 MHz from a device shall not exceed the following average limits when measured using a resolution bandwidth of 1 MHz.

Frequency in MHz	E.i.r.p. in a Resolution Bandwidth of 1 MHz
960-1 610 MHz	-65.3 dBm
1 610-1 990 MHz	-53.3 dBm
1 990-3 100 MHz	-51.3 dBm
3 100-10 600 MHz	-41.3 dBm
Above 10 600 MHz	-51.3 dBm

6.4 Setup Photographs:

Test Setup, Fundamental Emissions



**6.5 Plots/Data:**

Worst-case antenna polarization, -47.07 dBm

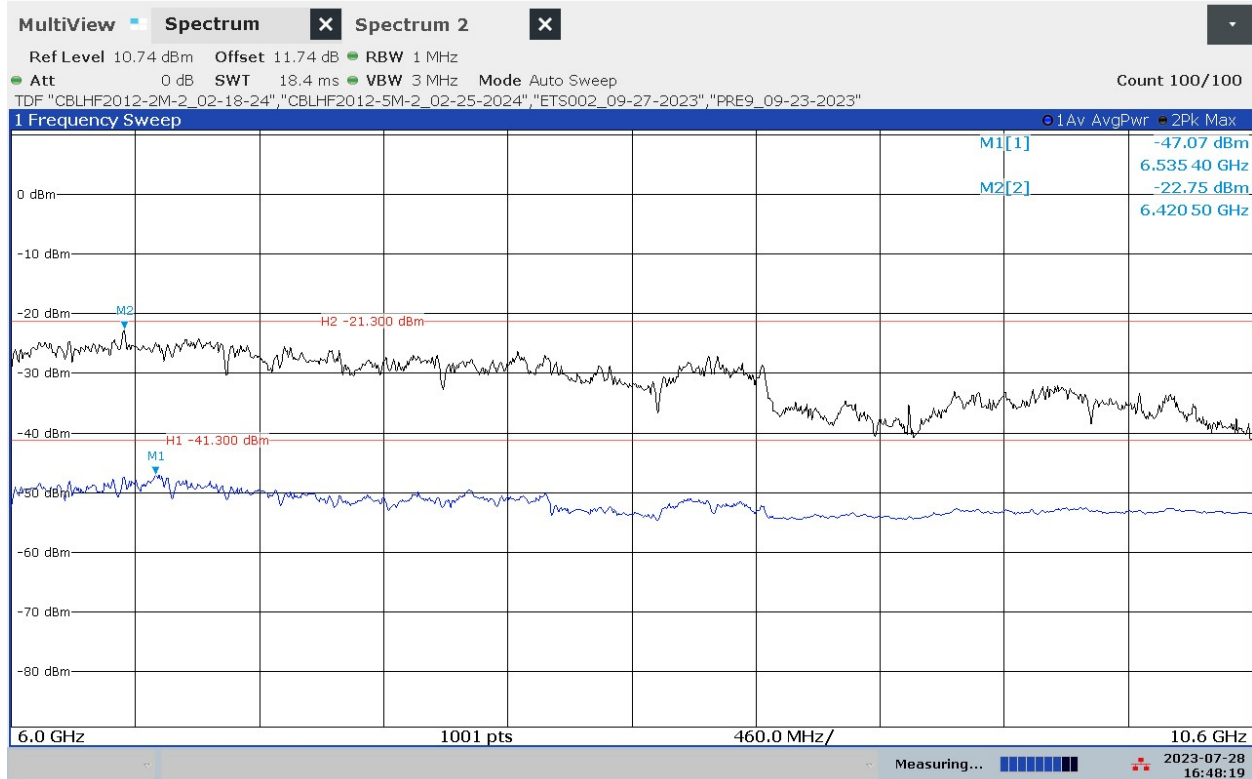

04:48:19 PM 07/28/2023

Note: The antenna factor, cable loss, and pre-amp gain were internally compensated as TDF.

Product Standard: FCC Part 15, Subpart F, §15.511, RSS-220 and FCC Waver DA-22-133A1-c3				Limit applied: per §15.511, RSS-220 and FCC Waver DA-22-133A1-c3			
				Pretest Verification w/BB source: Yes			
Test Date	Test Personnel/ Initials	Supervising Engineer/ Initials	Input Voltage	Mode	Atmospheric Data		
					Temp C°	Relative Humidity %	Atmospheric Pressure mbar
07/28/2023	Vathana Ven <i>VSV</i>	N/A	120VAC 60Hz	Continuous sweep	27	39	1006

Deviations, Additions, or Exclusions: None

## 7 Occupied Bandwidth

### 7.1 Method

Tests are performed in accordance with ANSI C63.10 and FCC Waver DA-22-133A1-c3.

**TEST SITE:** 10m ALSE

**The 10m ALSE** is 13m (Length) x 21m (Depth) x 10m (Height) with the effective size in terms of space from the tips of the absorber is 12m (Length) x 20m (Depth) x 8.5m (Height). This chamber achieves broadband performance using a unique arrangement of hybrid and ferrite tile absorber. This chamber has a built in 3m diameter turntable (Embedded type). The metal structure of the table makes electrical connection around the entire circumference of the turntable to the ground plane with a metal brush type connection. The turntable is located on one end of the chamber and the antennas are mounted 3 and 10 meters away at the other end of the chamber on the adjustable an Antenna Mast. The antenna mast is a non-conductive bore sighted type with remote control of antenna height and polarization. The Antenna Mast and the turntable can be remotely controlled through the controller located in the adjacent Control room. A Styrofoam table 80 cm high is used for table-top equipment.

### 7.2 Test Equipment Used:

Asset	Description	Manufacturer	Model	Serial	Cal Date	Cal Due
DAV006'	Weather Station	Davis	6250	MS191218071	02/21/2023	02/21/2024
EMC04'	ANTENNA, RIDGED GUIDE, 18-40 GHZ	EMCO	3116	2090	01/26/2023	01/26/2024
CBLHF2012-5M-2'	5m 9kHz-40GHz Coaxial Cable - SET2	Huber & Suhner	SF102	252676002	02/25/2023	02/25/2024
CBLHF2012-2M-2'	2m 9kHz-40GHz Coaxial Cable - SET2	Huber & Suhner	SF102	252675002	02/18/2023	02/18/2024
ROS005-1'	Signal and Spectrum Analyzer	Rohde and Shwartz	FSW43	100646	11/18/2022	11/18/2023
PRE9'	100MHz-40GHz Preamp	MITEQ	NSP4000-NFG	1260417	09/23/2022	09/23/2023

#### Software Utilized:

Name	Manufacturer	Version
None		

### 7.3 Results:

The sample tested was found to Comply.

Occupied Bandwidth Limits (FCC Part 15, Subpart F, §15.511, RSS-220, FCC Waver DA-22-133A1-c3):

The intentional emissions generated by the HEXWAVE device must be completely contained within the 6-10.6 GHz frequency range.



7.4 Setup Photographs:

Test Setup, Fundamental Emissions



**7.5 Plots/Data:**

Lower edge – M1 = 6.0156 GHz  
Upper edge – M2 = 10.587 GHz

The intentional emissions generated by the HEXWAVE device was completely contained within the 6-10.6 GHz frequency range.

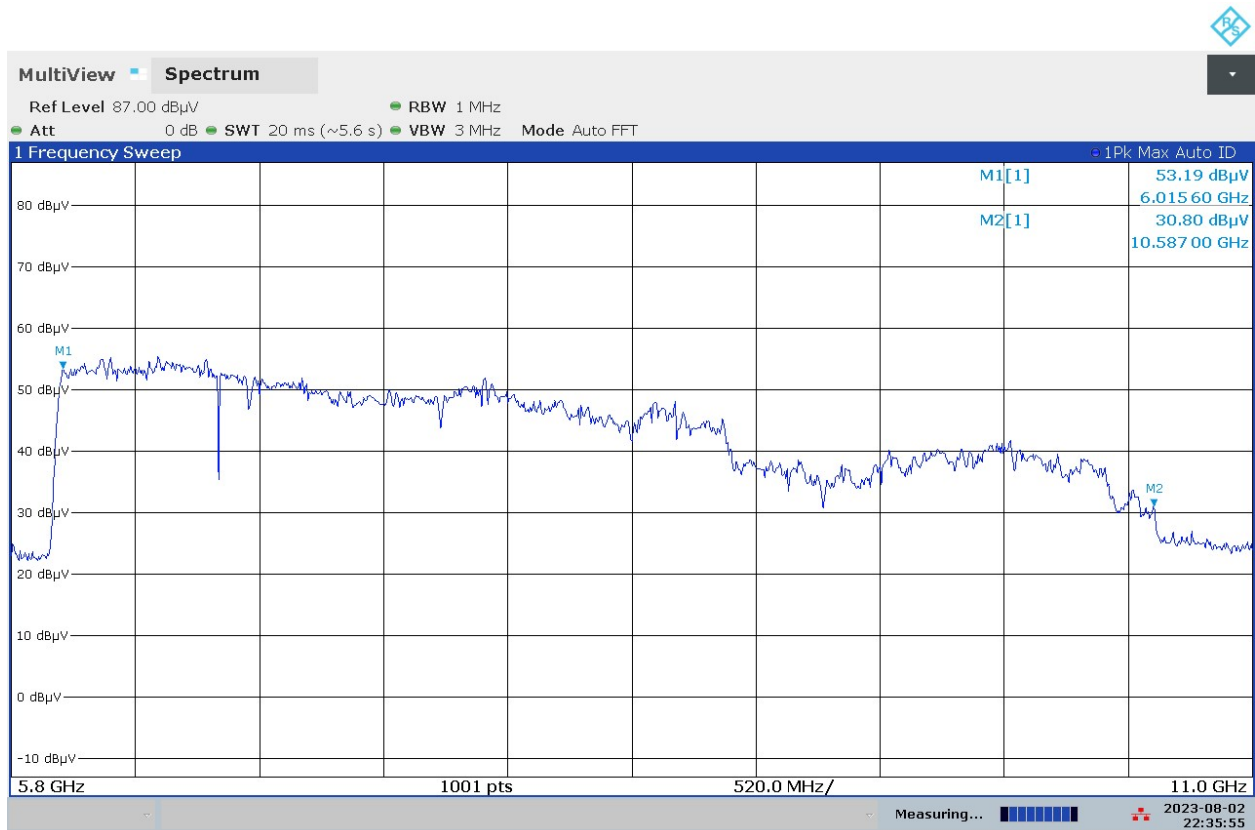

Note: The antenna factor, cable loss, and pre-amp gain were internally compensated as TDF.

Product Standard: FCC Part 15, Subpart F, §15.511, RSS-220 and FCC Waver DA-22-133A1-c3				Limit applied: per §15.511, RSS-220 and FCC Waver DA-22-133A1-c3 Pretest Verification w/BB source: Yes			
Test Date	Test Personnel/ Initials	Supervising Engineer/ Initials	Input Voltage	Mode	Atmospheric Data		
					Temp C°	Relative Humidity %	Atmospheric Pressure mbar
08/02/2023	Vathana Ven <i>VSV</i>	N/A	120VAC 60Hz	Continuous sweep	25	35	1007

Deviations, Additions, or Exclusions: None

**8 Total Transmit Time**

**8.1 Method**

Tests are performed in accordance with ANSI C63.10 and FCC Waver DA-22-133A1-c3.

**8.2 Results:**

The sample tested was found to Comply.

Total Transmit Time Limits (FCC Part 15, Subpart F, §15.511, RSS-220 FCC Waver DA-22-133A1-c3):

The total transmit time of the HEXWAVE system during a cycle will be less than 54 milliseconds and each cycle will be repeated with a period of no less than 100 milliseconds.

8.3 Plots/Data:

Hexwave System Transmit Time

Hexwave waiver state that:

“5) The total transmit time of the HEXWAVE system during a cycle will be less than 54 milliseconds and each cycle will be repeated with a period of no less than 100 milliseconds.”

Test Setup

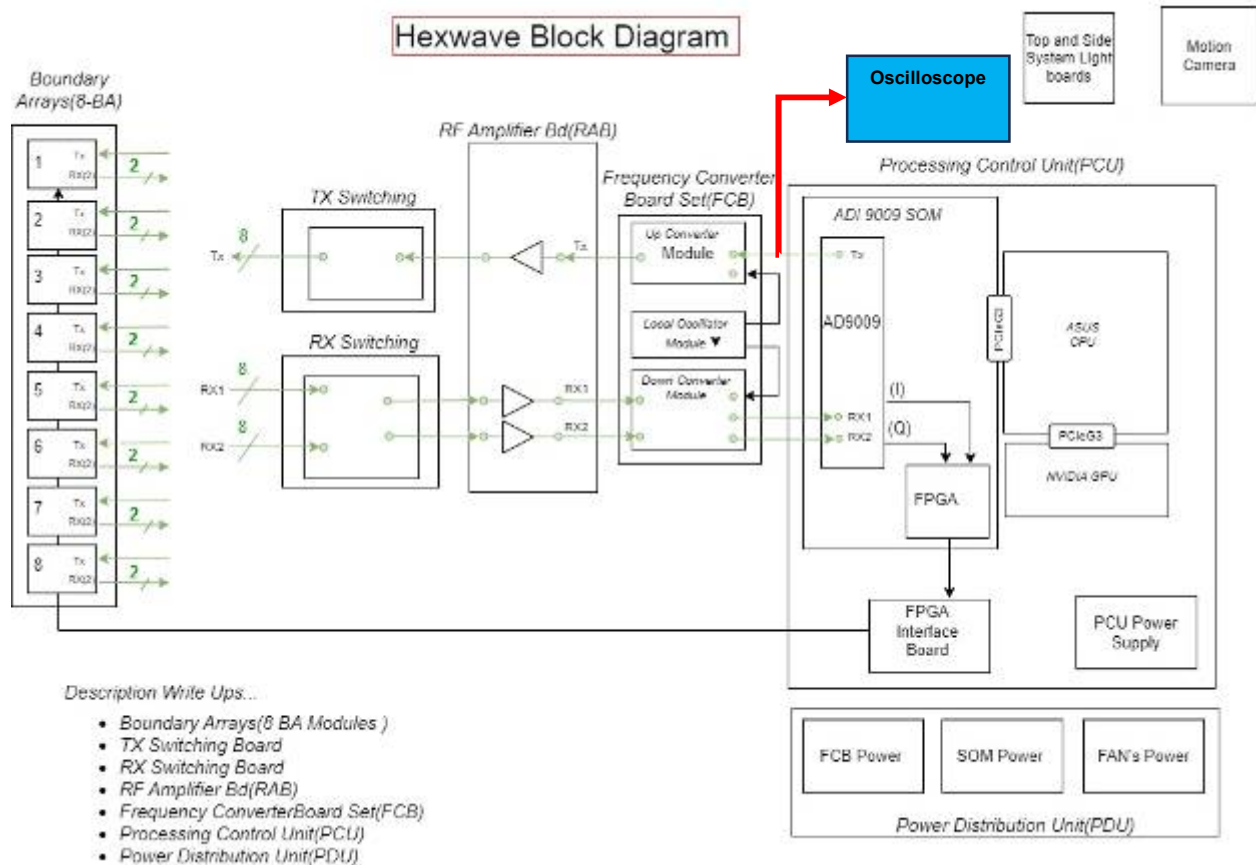

The measurement of the transmit cycle has been performed using high-speed oscilloscope where we directly connect output of AD9009 transmitter to Keysight Infinium Oscilloscope.



Duty-cycle measurements of Hexwave transmit cycle.



Blue marks showing a 100ms duty-cycle, during that we are executing two transmits.  
Each transmission is 26ms (Red markers).  
So, total transmit time during 100 milliseconds is 52 milliseconds.

Deviations, Additions, or Exclusions: Transmit Time/Duty-cycle measurements were provided by the client.

## 9 Unwanted Emissions

### 9.1 Method

The procedure described in Subclauses 6.3-6.6 and 9.9 of ANSI C63.10-2013 and Subclause 5.5.4 (field strength method) of ANSI C63.26-2015 were utilized to determine unwanted emissions.

Radiated emission measurements are performed from 9 kHz to 231 GHz. Measurements for frequencies less than or equal to 1 GHz are made with an EMI receiver employing a CISPR quasi-peak detector. Measurements for frequencies above 1 GHz are made with an EMI receiver or a spectrum analyzer employing an average detector and a peak detector.

Quasi-peak measurements are performed for frequencies less than or equal to 1 GHz. The quasi-peak level of radiated emissions was measured with a resolution bandwidth (RBW) of 9 kHz for frequencies below 30 MHz and 120 kHz for frequencies between 30 MHz to 1 GHz.

Both Peak and Average measurements are performed for frequencies above 1 GHz. The peak level of radiated emissions was measured with a resolution bandwidth (RBW) of 1 MHz, a video bandwidth (VBW) of 3 MHz, and a peak detector. The average level of radiated emissions was measured with a resolution bandwidth (RBW) of 1 MHz, a video bandwidth (VBW) of 3 MHz, and an RMS detector with trace averaging.

Radiated emissions measurement is performed at 10 meters distance for frequencies below 1 GHz, 3 meters for frequency between 1 GHz and 18 GHz, and 1 meter for frequencies above 18 GHz. If the emission level is too low for measurement at that distance, a pre-amplifier is used and/or the test is performed at a closer distance.

The EUT is configured to transmit continuously at its maximum data rate. The EUT is placed 80 cm in height for frequencies below 1 GHz and 1.5 meters in height for frequency above 1 GHz. For portable or handheld devices, the EUT is manipulated through three orthogonal orientations.

For radiated emissions measurements Below 30 MHz, the measuring antenna is positioned with its plane perpendicular to the ground at the specified distance from the EUT. The lowest height of the measurement antenna is 1 m above the ground. During the test, the EUT is rotated 0° through 360° and the measuring antenna orientations are varied (parallel, perpendicular, and ground-parallel) during the search for maximum emission level. EMI receiver's resolution bandwidth is set at 9 kHz.

For radiated emissions measurements between 30 MHz to 18 GHz, measurements are performed with the EUT rotated from 0° to 360°, the measuring antenna height scanned between 1 to 4 meters, and the measuring antenna varied for both horizontal and vertical polarization, to determine the maximum emission level.

For radiated emissions measurements between 18 GHz to 100 GHz, handheld measurement is performed at a far field distance. As the surfaces of the EUT are scanned, the test antenna is kept pointed toward the EUT and the measuring antenna polarization is varied slowly to cover all possible polarizations and orientations of the emission(s).

Data included is representative of the worst-case configuration (the configuration which resulted in the highest emission levels). Plots below are corrected for distance, cables, preamp, filters, antenna factors, and conversion factors then compared to the limits.

**TEST SITE:** 10m ALSE

**The 10m ALSE** is 13m (Length) x 21m (Depth) x 10m (Height) with the effective size in terms of space from the tips of the absorber is 12m (Length) x 20m (Depth) x 8.5m (Height). This chamber achieves broadband performance using a unique arrangement of hybrid and ferrite tile absorber. This chamber has a built in 3m diameter turntable (Embedded type). The metal structure of the table makes electrical connection around the entire circumference of the turntable to the ground plane with a metal brush type connection. The turntable is located on one end of the chamber and the antennas are mounted 3 and 10 meters away at the other end of the chamber on the adjustable an Antenna Mast. The antenna mast is a non-conductive bore sighted type with remote control of antenna height and polarization. The Antenna Mast and the turntable can be remotely controlled through the controller located in the adjacent Control room. A Styrofoam table 80 cm high is used for table-top equipment.

**Measurement Uncertainty**

Measurement	Frequency Range	Expanded Uncertainty (k=2)	Ucispr
Radiated Emissions, 10m	30-1000 MHz	5.6 dB	6.3 dB
Radiated Emissions, 3m	30-1000 MHz	4.9 dB	6.3 dB
Radiated Emissions, 3m	1-6 GHz	4.4 dB	5.2 dB
Radiated Emissions, 3m	6-15 GHz	4.9 dB	5.5 dB
Radiated Emissions, 3m	15-18 GHz	4.6 dB	5.5 dB
Radiated Emissions, 3m	18-40 GHz	4.6 dB	N/A

As shown in the table above our radiated emissions  $U_{lab}$  is less than the corresponding  $U_{CISPR}$  reference value in CISPR 16-4-2 Table 1, hence the compliance of the product is only based on the measured value, and no measurement uncertainty correction is required, based on CISPR 22 and CISPR 11 (for 2006 and later revisions) Clause 11.

**Sample Calculation**

The field strength is calculated by adding the Antenna Factor and Cable Factor, and subtracting the Amplifier Gain (if any) from the measured reading. The basic equation with a sample calculation is as follows:

$$FS = RA + AF + CF - AG$$

- Where
- FS = Field Strength in dB $\mu$ V/m
  - RA = Receiver Amplitude (including preamplifier) in dB $\mu$ V
  - CF = Cable Attenuation Factor in dB
  - AF = Antenna Factor in dB
  - AG = Amplifier Gain in dB

In the following table(s), the reading shown on the data table reflects the preamplifier gain. An example for the calculations in the following table is as follows.

Assume a receiver reading of 52.0 dB $\mu$ V is obtained. The antenna factor of 7.4 dB and cable factor of 1.6 dB is added. The amplifier gain of 29 dB is subtracted, giving a field strength of 32 dB $\mu$ V/m. This value in dB $\mu$ V/m was converted to its corresponding level in  $\mu$ V/m.

- RA = 52.0 dB $\mu$ V
- AF = 7.4 dB/m
- CF = 1.6 dB
- AG = 29.0 dB
- FS = 32 dB $\mu$ V/m

To convert from dB $\mu$ V to  $\mu$ V or mV the following was used:

$$UF = 10^{(NF / 20)} \text{ where } UF = \text{Net Reading in } \mu\text{V}$$
$$NF = \text{Net Reading in dB}\mu\text{V}$$

**Example:**

$$FS = RA + AF + CF - AG = 52.0 + 7.4 + 1.6 - 29.0 = 32.0$$
$$UF = 10^{(32 \text{ dB}\mu\text{V} / 20)} = 39.8 \mu\text{V/m}$$

Alternately, when BAT-EMC Emission Software is used, the "Level" includes all losses and gains and is compared directly in the "Margin" column to the "Limit". The "Correction" includes Antenna Factor, Preamp, and Cable Loss. These are already accounted for in the "Level" column.

**9.2 Test Equipment Used:**

Asset	Description	Manufacturer	Model	Serial	Cal Date	Cal Due
IW002'	2 meter Armored cable	Insulated Wire	2800-NPS	002	10/11/2022	10/11/2023
145-420'	Receiver to floor cable	Utiflex	UFB311A-2-0591-70070	145-420	02/18/2023	02/18/2024
HS001'	DC-18GHz cable 1.5m long	Huber & Suhner	SucoFlex 106A	HS001	01/25/2023	01/25/2024
HS003	10m under floor cable	Huber-Schuner	10m-1	HS003	02/18/2023	02/18/2024
145145'	Broadband Hybrid Antenna 30 MHz - 3 GHz	Sunol Sciences Corp.	JB3	A122313	06/23/2023	06/23/2024
PRE10'	30-1000MHz pre-amp	ITS	PRE10	PRE10	02/17/2023	02/17/2024
ETS002'	1-18GHz DRG Horn Antenna	ETS Lindgren	3117	00143260	09/27/2022	09/27/2023
PRE9'	100MHz-40GHz Preamp	MITEQ	NSP4000-NFG	1260417	09/23/2022	09/23/2023
145-408'	10m Chamber - 3m Track B In-floor Cable	Huber + Suhner	sucoflex 106-11000mm	001	07/19/2023	07/19/2024
EMC04'	ANTENNA, RIDGED GUIDE, 18-40 GHZ	EMCO	3116	2090	01/26/2023	01/26/2024
OML3'	WR12 Harmonic Mixer, 60 to 90GHz	Oleson Microwave Lab	M12HWD	E21011-1	11/30/2022	11/30/2023
ROS005-1'	Signal and Spectrum Analyzer	Rohde and Shwartz	FSW43	100646	11/18/2022	11/18/2023
CBLHF2012-5M-2'	5m 9kHz-40GHz Coaxial Cable - SET2	Huber & Suhner	SF102	252676002	02/25/2023	02/25/2024
CBLHF2012-2M-2'	2m 9kHz-40GHz Coaxial Cable - SET2	Huber & Suhner	SF 102	252675002	02/18/2023	02/18/2024
OML4'	WR19 Harmonic Mixer, 40 to 60GHz	Oleson Microwave Lab	M19HWD	U21011-1	11/30/2022	11/30/2023
OML2'	WR08 Harmonic Mixer, 90 to 140GHz	Oleson Microwave Lab	M08HWA	F21011-1	11/30/2022	11/30/2023
OML4'	OML Horn Antenna	Oleson Microwave Lab	M19RH	Not labeled	11/30/2022	11/30/2023
OML3'	OML Horn Antenna	Oleson Microwave Lab	M12RH	Not labeled	11/30/2022	11/30/2023
OML2'	OML Horn Antenna	Oleson Microwave Lab	M08RH	Not labeled	11/30/2022	11/30/2023
PRE12'	Pre-amplifier	Com Power	PAM-118A	18040117	12/17/2022	12/17/2023
DAV006'	Weather Station	Davis	6250	MS19121807 1	02/21/2023	02/21/2024
145-420'	Receiver to floor cable	Utiflex	UFB311A-2-0591-70070	145-420	02/18/2023	02/18/2024
145-424'	9kHz to 40GHz Cable	Huber and Suhner	Sucoflex	145-424	02/18/2023	02/18/2024
145-422'	10Amp Pre-amp to under floor	Utiflex	UFB311A-0-2756-70070	145-422	02/18/2023	02/18/2024
145108'	EMI Test Receiver (20Hz - 40GHz)	Rohde & Schwarz	ESIB40	100209	06/28/2023	06/28/2024

**Software Utilized:**

Name	Manufacturer	Version
BAT-EMC	Nexio	2022.0.27.0

**9.3 Results:**

The sample tested was found to Comply.

Unwanted emissions Limits (FCC Part 15, Subpart F, §15.511, RSS-220, FCC Waver DA-22-133A1-c3):

- (c) The radiated emissions at or below 960 MHz from a device operating under the provisions of this section shall not exceed the emission levels in § 15.209. The radiated emissions above 960 MHz from a device operating under the provisions of this section shall not exceed the following average limits when measured using a resolution bandwidth of 1 MHz:

Frequency in MHz	EIRP in dBm
960-1610	-53.3
1610-1990	-51.3
1990-10600	-41.3
Above 10600	-51.3

9.4 Setup Photographs:

9 kHz-30 MHz Test Setup, X-Axis





9 kHz-30 MHz Test Setup, Y-Axis



9 kHz-30 MHz Test Setup, Z-Axis





30-1000 MHz Test Setup



1-18 GHz Test Setup

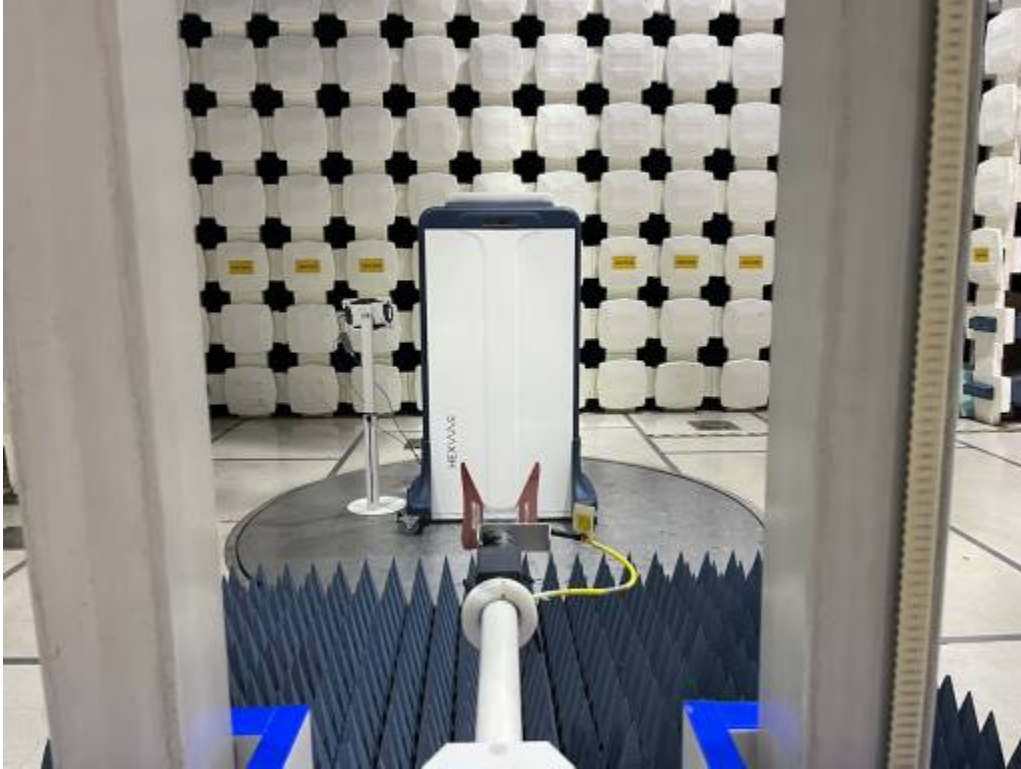



18-40 GHz Test Setup

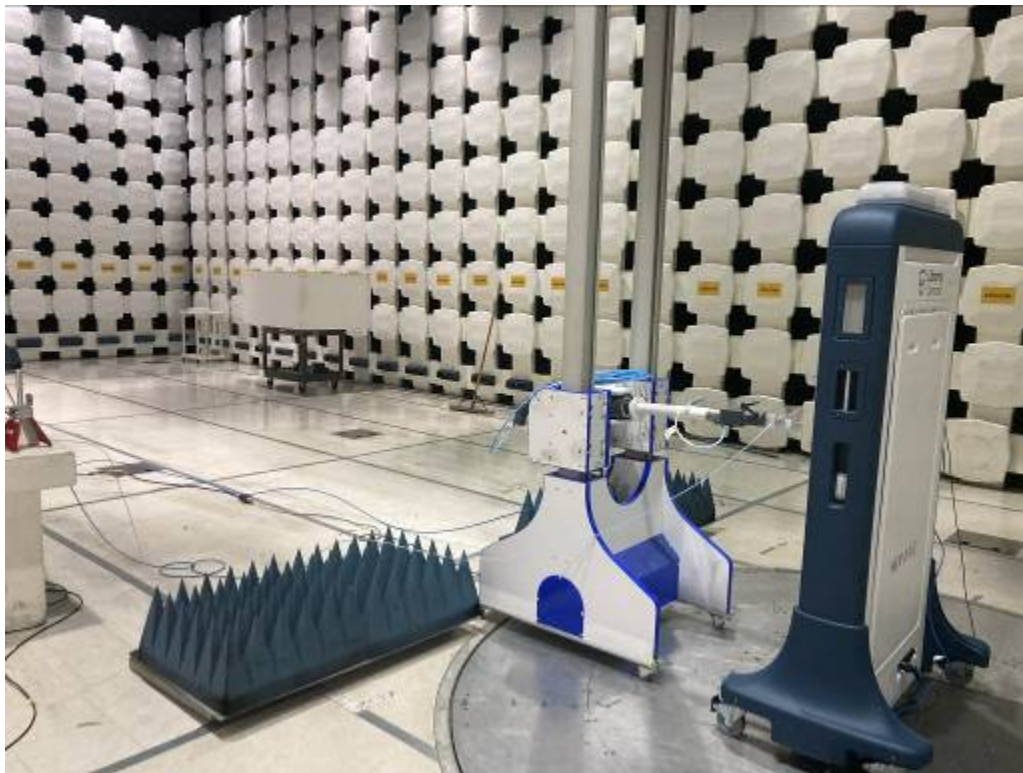

40-60 GHz Test Setup

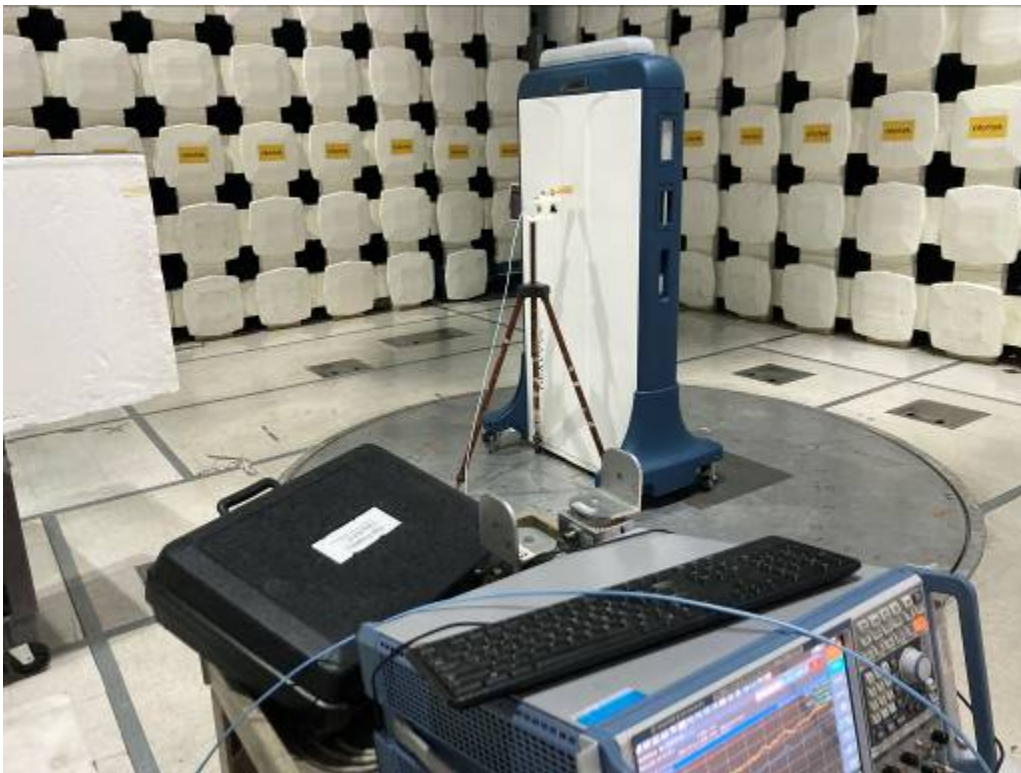



60-90 GHz Test Setup

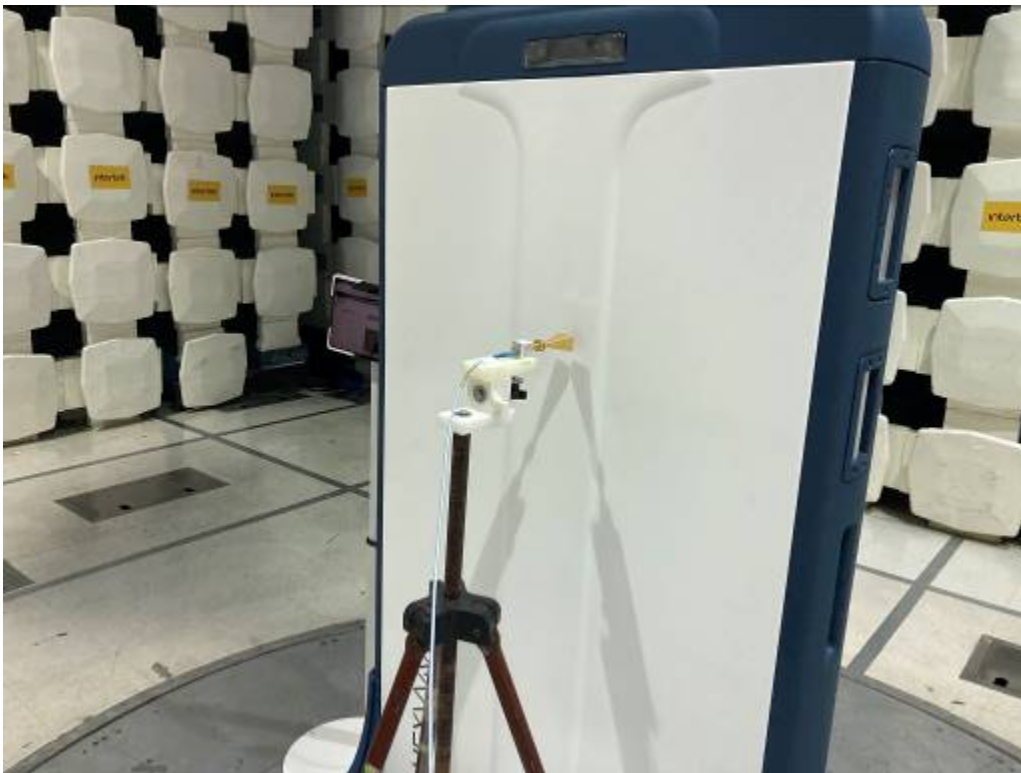
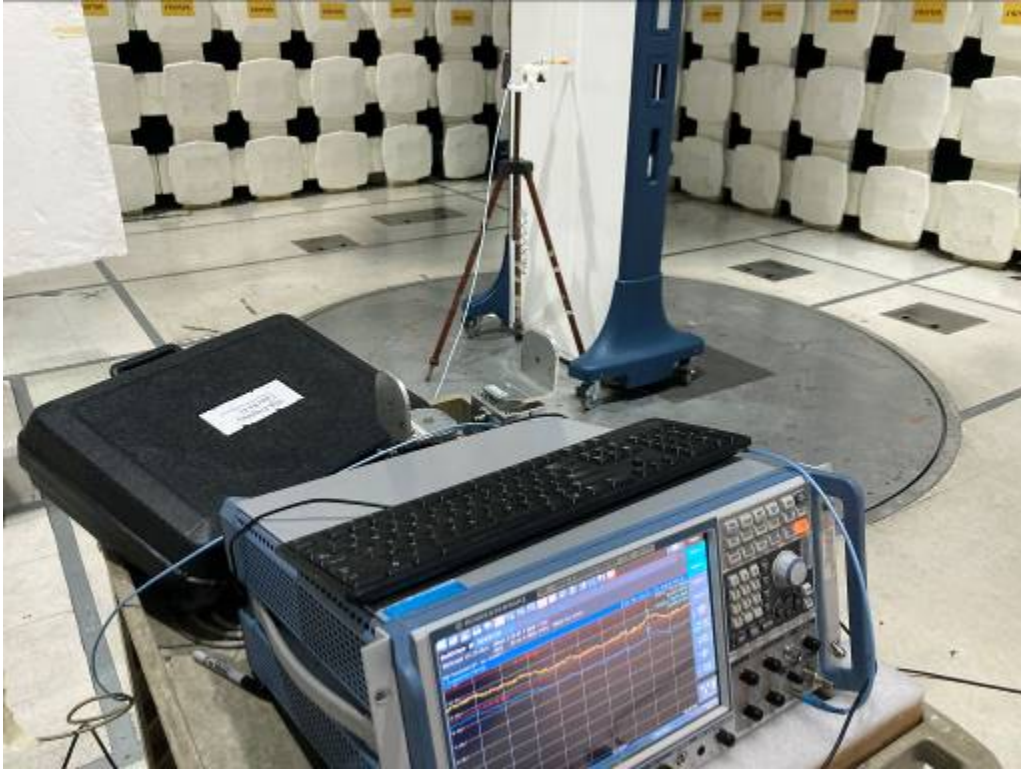

90-100 GHz Test Setup

