

## Antenna specification

### Antenna Sample Confirmation From

<b>Name of supplier</b>	ShenZhen Aihui Technology Co. , Ltd				
<b>Customer name</b>	Hua Yi				
<b>Sample name</b>	PM1005				
<b>model</b>					
<b>Sample size</b>	Main antenna; PM1005P-WIFI-Z-AH; 270mm (0.81) Generation 4, Black. Secondary antenna; PM1005P-WIFI-F-AH: 280mm (0.81) generation 4, Gray.				
<b>Inspection item</b>	<b>Performance test</b>	<b>Visual inspection</b>	<b>Structure</b>	<b>In the news</b>	<b>Test results</b>
<b>Notes</b>					

# Shenzhen Aihui Technology Co. , Ltd.

Quality Audit		Project Audit		Business confirm ation	
The following is to be completed by the client					
Customer feedback					
Customer signature/seal	date:				

## Antenna Test Report

Test Unit: Shenzhen Aihui Technology Co. , Ltd.

Address: 402TEL: 0755-23203435fax: 0755-23203435, Block C, Juxin Science and  
Technology Industrial Park, Nanchang community, xixiang, Baoan District, Shenzhen

# Shenzhen Aihui Technology Co. , Ltd.

Materials	FPC coaxial line		
Antenna type	MonopoleType	Polarization mode	Linear
Application scenario			
Working band	WIFI /BT	VSWR	≤2
Power	Max : 2W	Impedance	50Ω
dBi			
Test Equipment	HPE5071C、Shielding Room、3D automatic turntable		
<p><b>Antenna Description: :</b></p> <p><b>1. Grounding processing and picture description: no</b></p> <p><b>2. Need to change the motherboard to match: no</b></p> <ul style="list-style-type: none"><li>● Test voltage: 3.6V, check the antenna contact is good before testing.</li><li>● The RF cable of the integrated tester is kept in a natural state and can not be curled.</li></ul> <p>Specification:test the specified power level, all indicators must conform to the specifications.</p>			

1. Project Image
2. Test Fixture
3. Antenna matching circuit
4. S11 test
5. Antenna passive efficiency and gain
6. Darkroom test equipment and data
7. Schematic diagram of antenna assembly
8. Antenna environment handling
9. Antenna mass production index
10. Structural drawing

## 1. Project Image

The final verification antenna performance prototype in our company for at least one year, easy to analyze and solve the problem of antenna mass production, to ensure the quality of antenna shipment

## 2. Test Fixture

Objective: to test the passive parameters of antenna as accurately as possible. Making

Method: the handset is made of a 50 ohm coaxial cable, one end of which is connected to the test point of the back end of the matching circuit of the handset motherboard (front end of the RF test hole) , and the other end is connected to the SMA joint. The diagram is as follows:

## 3. Antenna matching circuit

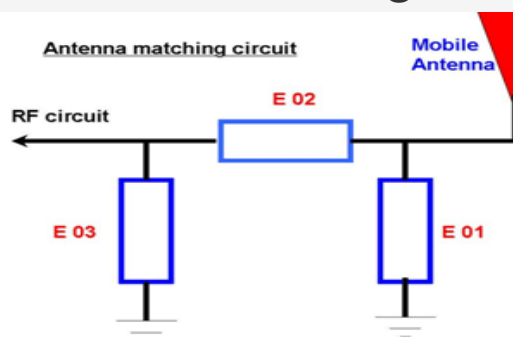

### Modify

E01	E02	E03
No	No	No

Note: The match is unmodified.

## 4.S11 test

4.0 4.0s11 test method description of test equipment: Network Analyzer (E5071C) test method: a 50 ohm CABLE is used to export from the instrument test port. The SMA connector for connecting the handset is calibrated using a calibration piece, record the echo loss and standing wave ratio corresponding to the relevant frequency points. The test schematic is as follows:

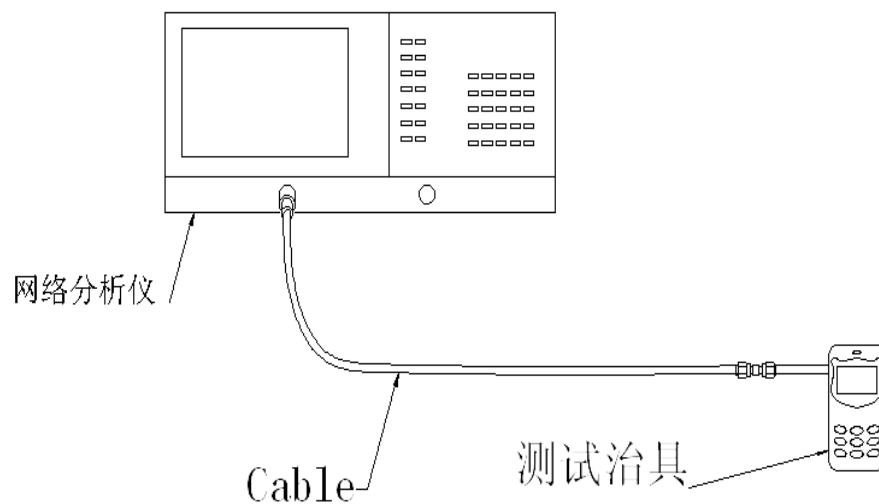

## 5.Darkroom test equipment and data

Frequency Band	2.4WIFI B模			N模		
channel	L	M	H	L	M	H
TRP	12.95	12.85	13.56	11.03	11.14	11.68
TIS			-80.52			-67.71
Frequency Band	G模			5G WIFI A模		
channel	L	M	H	L	M	H
TRP	10.91	10.56	11.51	8.36	8.15	8.15
TIS			-67.25			-67.35

WIFI Test data:		
2.4G WIFI:		
Frequency (MHZ)	Efficiency (%)	Gain (dbi)
2400	54.25	1.30
2410	56.32	1.25
2420	57.41	1.14
2430	59.68	1.03
2440	60.24	1.50
2450	61.05	1.54
2460	60.34	1.56

# Shenzhen Aihui Technology Co. , Ltd.

2470	62.35	1.35
2480	59.54	1.44
2490	57.41	1.63
2500	58.33	1.54

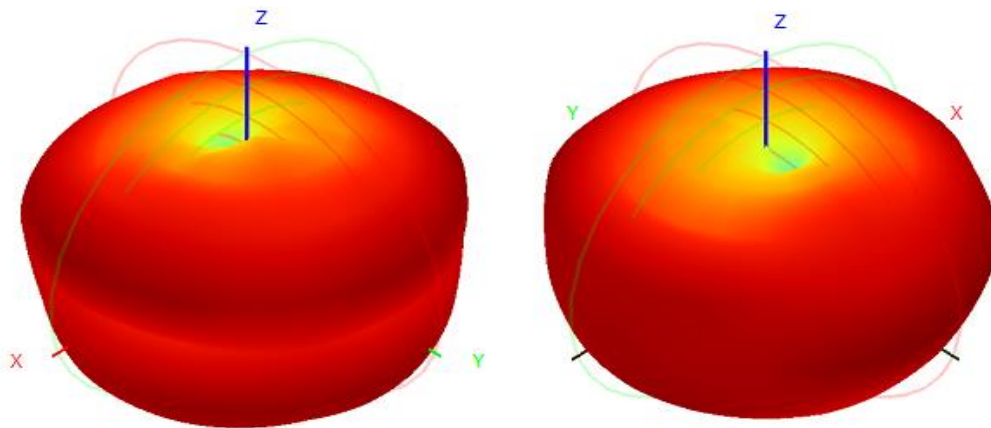

WIFI Test data:		
5G WIFI:		
Frequency (MHZ)	Efficiency (%)	Gain (dbi)
4900	56.33	1.24
5000	54.25	1.08
5100	57.85	1.54
5200	59.63	1.44
5300	60.24	1.48

Address: 402TEL: 0755-23203435fax: 0755-23203435, Block C, Juxin Science and Technology Industrial Park, Nanchang community, xixiang, Baoan District, Shenzhen



# Shenzhen Aihui Technology Co. , Ltd.

5400	61.44	1.49
5500	62.03	1.55
5600	62.21	1.09
5700	57.33	1.59
5800	54.25	1.54
5900	56.36	1.45

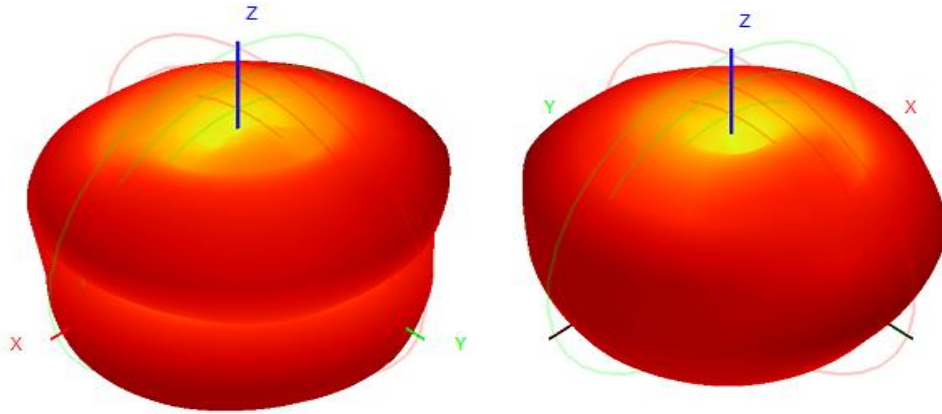

## 6. Test Equipment

Test system: shielded darkroom

The temperature was  $22^{\circ}\text{C} \pm 3^{\circ}\text{C}$  and the humidity was  $50\% \pm 15\%$

Test equipment: when testing passive data, use the Network analyzer AGILENTE5071C to test active data, use the omnibus CMW500

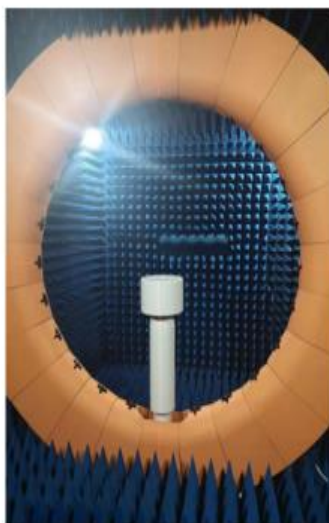

## 7.Active antenna test data

/

## 8.Schematic diagram of antenna assembly



## 9.Antenna environment handling

## 10.Antenna mass production index

When the antenna is mass-produced, the	Standard for volume
--	---------------------

<p>standing wave ratio is taken as the mass-produced test standard. Based on the differences of the project itself, the following criteria are given:</p>	<p>production</p>
	<p>VSWR (Mass Production performance) &amp; LT; VSWR(recognition performance) 0.5</p>

## 10.1 Structural drawings

