

承认书

SPECIFICATION FOR APPROVAL

客户名称 (CUSTOMER): 意珑科技有限公司

客户料号 (CUSTOMER P/N):

品名 (DESCRIPTION): DATE: 2024-6-20

规格 (SPECIFICATION): G44开槽+6.9UH背胶50mm REV.NO.: A0

鸿日昇威科技承认签核、盖章

部门	确认/日期	审核/日期	批准/日期	(盖公司公章)
品质	董晚红 2024-6-20	吕惠 2024-6-20	韦函满 2024-6-20	
工程	何伟华 2024-6-20	韦立红 2024-6-20	韦立红 2024-6-20	

备注:

意珑智能科技承认签核、盖章

部门	确认/日期	审核/日期	批准/日期	(盖公司公章)
开发工程师				
采购				
品质				

备注:

深圳市鸿日昇威科技有限公司

HRSW ELECTRONICS CO.,LTD

ADD: 深圳市龙华新区观澜环观中路48号1栋2楼

TEL: +86-755-23461055 FAX: +86-0755-28015170

page: 1/3

SPECIFICATION FOR APPROVAL

1. MECHANICAL DIMENSION (UNIT:mm)

2. SCHEMATICS:

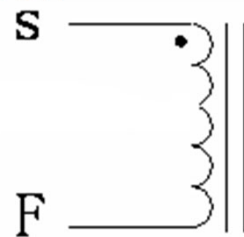
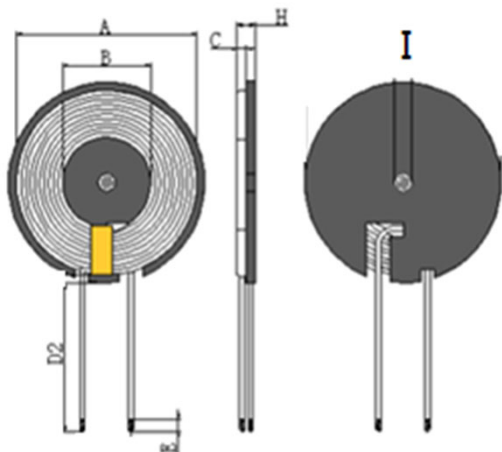

1. 线圈贴磁片，磁片尺寸
43.5*0.8*8.0
开L线槽。
2. 线圈出线位置
缠胶纸 1-2Ts;
3. 隔磁片底部要贴不掏孔背胶
4. 磁片中间加7.8*2.1磁铁

A	B	C	D2	E	H	I			I
43.5±1.0	13.5±0.5	0.8±0.05	50±3	4±2	2.8MAX	8±0.5			

3. WINDING:

STEP	START-FINISH	WIRE TYPE	TURNS	TAPE	REMARK
N1	S-F	丝包线 ϕ 0.08*105mm 2UEW	12TS (Ref)		

4. ELECTRICAL SPECIFICATION:

ITEM	L	DCR		Q值	HI-POT
TEST	线圈加磁片	S-F			
CON	100KHz, 0.25V	AT 25°C			
SPEC	6.9uH±10%	60m Ω Max			

5. BILF OF MATERIAL:

NO.	ITEM	MATERIAL SPECIFICATION	MANUFACTURER	SGS NO.
1	丝包线0.08*105股	丙酮丝包线0.08*105股	NANJINGJINNINGCO,LTD	
2	无铅锡条	无铅锡条	QIAODO	
3	磁片	ϕ 44*0.8*8.0锰锌硬磁片开L槽	TAIYI CO.,LTD	
4	胶水	黄胶9999	LIANCHENG CO.,LTD	
5	高温胶纸	7mm宽高温胶纸	CUDAK CO.,LTD	
6	磁铁	7.8*2.1	TAIYI CO.,LTD	
7	背胶	ϕ 41.8*0.1	CUDAK CO.,LTD	

HRSW ELECTRONICS CO.,LTD	PART NO	
	TITLE	G44开槽+7.2UH背胶50mm
DRAWN BY	CHECKED BY	APPROVED BY

何伟华	韦立红	韦立红
-----	-----	-----

SPECIFICATION FOR APPROVAL

6. SAMPLE TEST DATA									
6. 1DIMENSION TEST (UNIT:mm)									
TEST ITEM	A	B	C	D	E	H	I		
SPEC	43.8±1.0	13.5±0.5	0.8±0.05	50±3	4±2	2.8MAX	8±0.5		
1	43.87	13.59	0.79	51	4.00	2.55	7.99		
2	43.89	13.67	0.81	49	3.60	2.56	8.01		
3	43.91	13.68	0.76	50.1	4.10	2.49	7.98		
4	43.98	13.59	0.82	49.2	4.12	2.52	8.02		
5	43.97	13.57	0.78	50.1	3.99	2.50	8		
6									
7									
8									
9									
10									
MAX	43.98	13.68	0.82	51.00	4.12	2.56	8.02		
MIN	43.87	13.57	0.76	49.00	3.60	2.49	7.98		
AVERAGE	43.92	13.62	0.79	49.88	3.96	2.52	8.00		
6. 2ELECTRICAL TEST									
TEST ITEM	L		DCR	IDC		Q	HI-POT		
	S-F		S-F						
TEST COND	100KHz/0.25v		AT 25°C						
SPEC	6.9uH ±10%		60mΩ (Max)						
1	6.98		42.00						
2	7.00		42.30						
3	6.99		42.50						
4	7.01		42.10						
5	7.02		42.35						
6									
7									
8									
9									
10									
MAX	7.02		42.50						
MIN	6.98		42.00						
AVERAGE	7.00		42.25						
HRSW ELECTRONICS CO., LTD					PART NO		G44开槽+6.9UH背胶50mm		
					TITLE				
DRAWN BY			CHECKED BY			APPROVED BY			
何伟华			韦立红			韦立红			